

Hoshizaki America, Inc.

Modular Flaker

Models

FD-1001MAH-C, MRH-C



“A Superior Degree
of Reliability”

www.hoshizaki.com

PARTS LIST



Number: 71302
Issued: 4-14-2010
Revised: 5-13-2015

CONTENTS

Auxiliary Codes.....	3
Note About Ordering Parts	3
A. Ice Flaker Assembly	4
FD-1001MAH-C	4
FD-1001MRH-C.....	7
B. Icemaking Unit.....	10
C. Water Circuit.....	12
D. Control Box Assembly.....	14
E. Accessories & Labels	15

Auxiliary Codes

FD-1001MAH-C

U-0 February 2009
A-0 February 2011
B-0 February 2012
B-1 March 2012
C-0 February 2013
C-1 August 2013
D-0 February 2014

FD-1001MRH-C

U-0 May 2009
V-0 January 2010
A-0 March 2011
B-0 January 2012
B-1 March 2012
C-0 January 2013
C-1 August 2013
D-0 January 2014
D-1 April 2014

Auxiliary Code Breakdown

The auxiliary code is the first two characters in the serial number. The first character indicates the year. Years progress or regress in alphabetical order. The series runs from "A" through "V" and the letters "I" and "O" are skipped. The second character indicates significant part changes within a year. Base is "0" and this number advances for each change.

Note About Ordering Parts

Most assemblies cannot be ordered as complete units; parts in the assemblies generally must be ordered separately.

A. Ice Flaker Assembly
FD-1001MAH-C
 U-0 to D-0

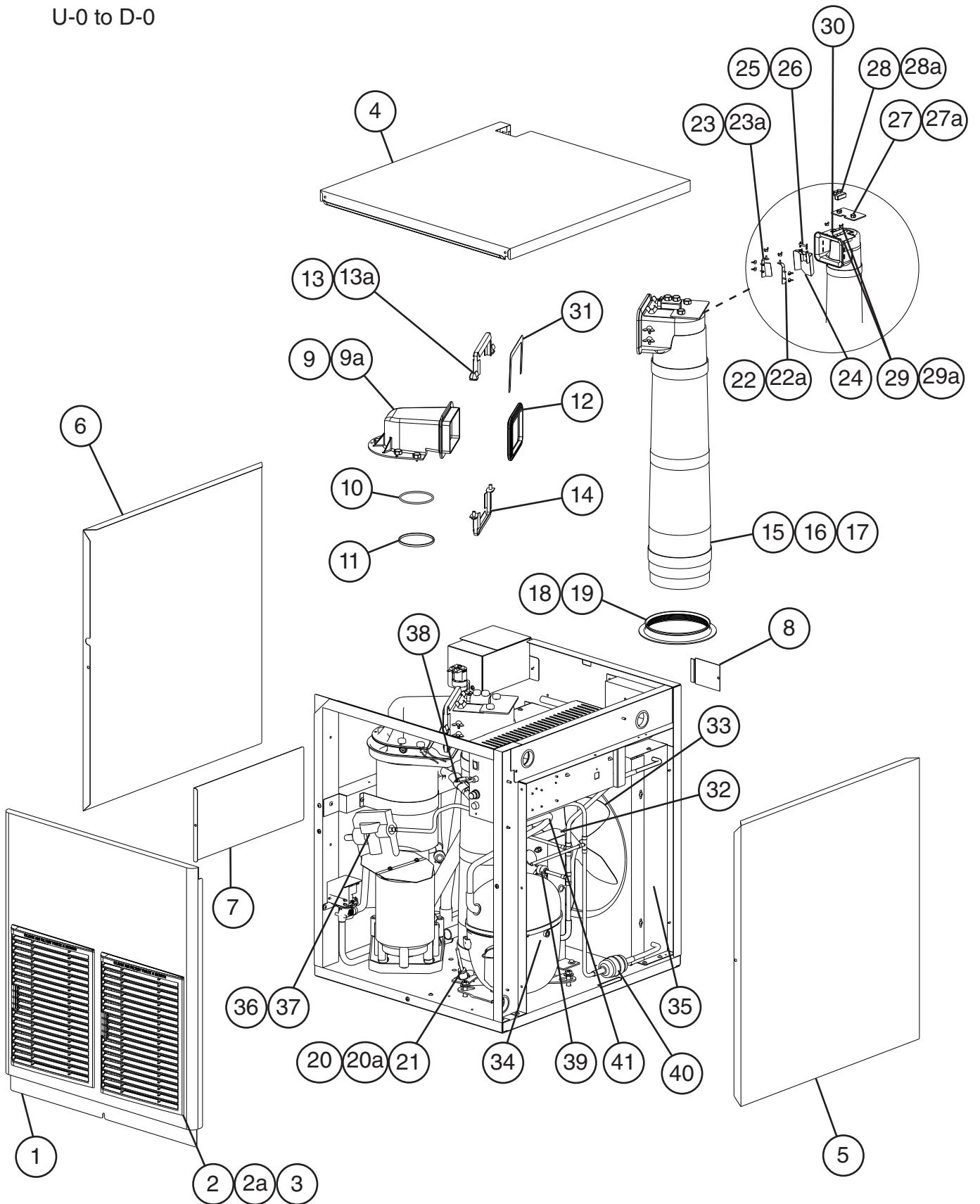

Title: A. Main Assembly & Refrigeration Circuit Model: FD-1001MAH-C											
Index No.	Description	Material or Model Number	Part Number	Required Number							
				U-0 to C-0	C-1 to D-0						
Main Assembly											
1	Front Panel		2A3824-01	1	1						
2	Louver		1A0548-01	2	2						
2a	Push Retainer		4A2414-01	6	6						
3	Air Filter		2A2063G01	2	2						
4	Top Panel		2A4042-01	1	1						
5	Right Side Panel		2A4432G01	1	1						
6	Left Side Panel		2A3897G01	1	1						
7	Control Box Cover		3A4544-01	1	1						
8	Junction Box Cover		433410-01	1	1						
9	Spout		104797-01	1	1						
9a	Thumbscrew		415949G08	5	5						
10	O-Ring		4A4755-03	1	1						
11	Nylon Ring		432661-02	1	1						
12	Spout-to-Chute Packing		321037-01	1	1						
13	Upper Spout Strap		328703-01	1	1						
13a	Wing Nut		7E12-0600	2	2						
14	Lower Spout Strap		321038G02	1	1						
15	Chute		2A1919-01	1	1						
16	Chute Insulation		2A1920-01	1	1						
17	Chute Tie		436531G01	3	3						
18	Chute Packing		432877-01	1	1						
19	Ring		3A1017-01	1	1						
20	Bin Control 1 Housing (infrared sensor)		3A3478-01	1	1						
20a	Thumbscrew		415949G08	1	1						
21	Bin Control 1 (infrared sensor)		4A4469-01	1	1						
22	Chute Baffle A		3A0400G01	1	1						
22a	Wing Nut		7E12-0400	2	2						
23	Chute Baffle B		3A0399G01	1	1						
23a	Wing Nut		7E12-0400	2	2						
24	Actuator		436848G01	1	1						
25	Shaft		436851-01	1	1						
26	Snap Pin		715S-0005	2	2						
27	Plate		4A2039-01	1	1						
27a	Thumbscrew		415949G10	2	2						
28	Bin Control 2 Proximity Switch (mechanical bin control)		4A2033-01	1	1						
28a	Thumbscrew		415949G08	2	2						
29	Bin Control 2 Bracket (mechanical bin control)		3A1744G01	1	1						
29a	Wing Nut		7E12-0400	2	2						
30	Truss Head Screw (ground)		7C32-0408	1	1						
31	Spout-to-Chute Bracket		4A1712-01	1	1						

Title: A. Main Assembly & Refrigeration Circuit Model: FD-1001MAH-C												
Index No.	Description	Material or Model Number	Part Number	Required Number								
				U-0 to C-0	C-1 to D-0							
Refrigeration Circuit												
32	Fan Motor		4A3158-01	1	1							
33	Fan Blade		4A0197-01	1	1							
34	Compressor		4A1322-01	1	-							
			3A6900-01		1							
35	Condenser		211663-02	1	1							
36	Thermostatic Expansion Valve		4A1117-01	1	1							
37	Thermostatic Expansion Valve Cover		4A1168-01	1	1							
38	Thermostatic Expansion Valve Bulb Holder		3A0112-01	1	1							
39	High-Pressure Switch		463180-04	1	1							
40	Drier		4A2666-01	1	1							
41	Heat Exchanger		3A7904G01	1	1							

A. Ice Flaker Assembly
FD-1001MRH-C
 U-0 to D-1

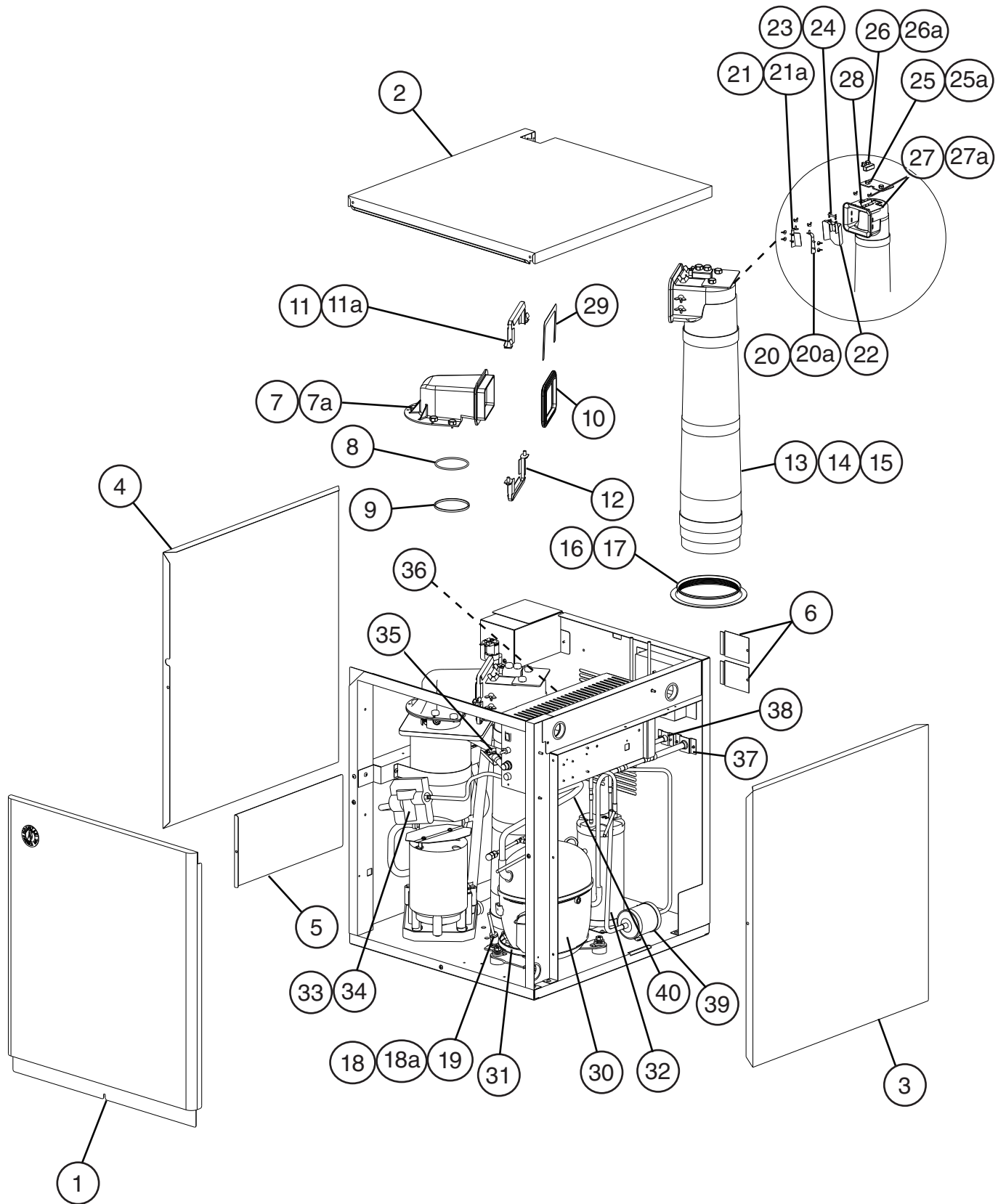

Title: A. Main Assembly & Refrigeration Circuit Model: FD-1001MRH-C											
Index No.	Description	Material or Model Number	Part Number	Required Number							
				U-0 to C-0	C-1 to D-1						
Main Assembly											
1	Front Panel		2A4601-01	1	1						
2	Top Panel		2A4042-01	1	1						
3	Right Side Panel		2A4432G01	1	1						
4	Left Side Panel		2A3897G01	1	1						
5	Control Box Cover		3A4544-01	1	1						
6	Junction Box Cover		433410-01	2	2						
7	Spout		104797-01	1	1						
7a	Thumbscrew		415949G08	5	5						
8	O-Ring		4A4755-03	1	1						
9	Nylon Ring		432661-02	1	1						
10	Spout-to-Chute Packing		321037-01	1	1						
11	Upper Spout Strap		328703-02	1	1						
11a	Wing Nut		7E12-0600	2	2						
12	Lower Spout Strap		321038G02	1	1						
13	Chute		2A1919-01	1	1						
14	Chute Insulation		2A1920-01	1	1						
15	Chute Tie		436531G01	3	3						
16	Packing		432877-01	1	1						
17	Nylon Ring		3A1017-01	1	1						
18	Bin Control 1 Housing (infrared sensor)		3A3478-01	1	1						
18a	Thumbscrew		415949G08	1	1						
19	Bin Control 1 (infrared sensor)		4A4469-01	1	1						
20	Chute Baffle A		3A0400G01	1	1						
20a	Wing Nut		7E12-0400	2	2						
21	Chute Baffle B		3A0399G01	1	1						
21a	Wing Nut		7E12-0400	2	2						
22	Actuator		436848G01	1	1						
23	Shaft		436851-01	1	1						
24	Snap Pin		715S-0005	2	2						
25	Plate		4A2039-01	1	1						
25a	Thumbscrew		415949G10	2	2						
26	Bin Control 2 Proximity Switch (mechanical bin control)		4A2033-01	1	1						
26a	Thumbscrew		415949G08	2	2						
27	Bin Control 2 Bracket (mechanical bin control)		3A1744G01	1	1						
27a	Wing Nut		7E12-0400	2	2						
28	Truss Head Screw (ground)		7C32-0408	1	1						
29	Spout-to-Chute Bracket		4A1712-01	1	1						

Title: A. Main Assembly & Refrigeration Circuit Model: FD-1001MRH-C											
Index No.	Description	Material or Model Number	Part Number	Required Number							
				U-0 to C-0	C-1 to D-1						
Refrigeration Circuit											
30	Compressor		4A1322-01	1	-						
			3A6900-01		1						
31	Crankcase Heater		434186-01	1	1						
32	Receiver Tank		437596-01	1	1						
33	Thermostatic Expansion Valve		4A3493-01	1	1						
34	Thermostatic Expansion Valve Cover		4A1168-01	1	1						
35	Thermostatic Expansion Valve Bulb Holder		3A0112-01	1	1						
36	High-Pressure Switch		463180-05	1	1						
37	Discharge Line Coupling		434072-01	1	1						
38	Liquid Line Coupling		426554-01	1	1						
39	Drier		4A1338-01	1	1						
40	Heat Exchanger		3A4651G01	1	1						

B. Icemaking Unit
FD-1001M_H-C
U-0 to D-1

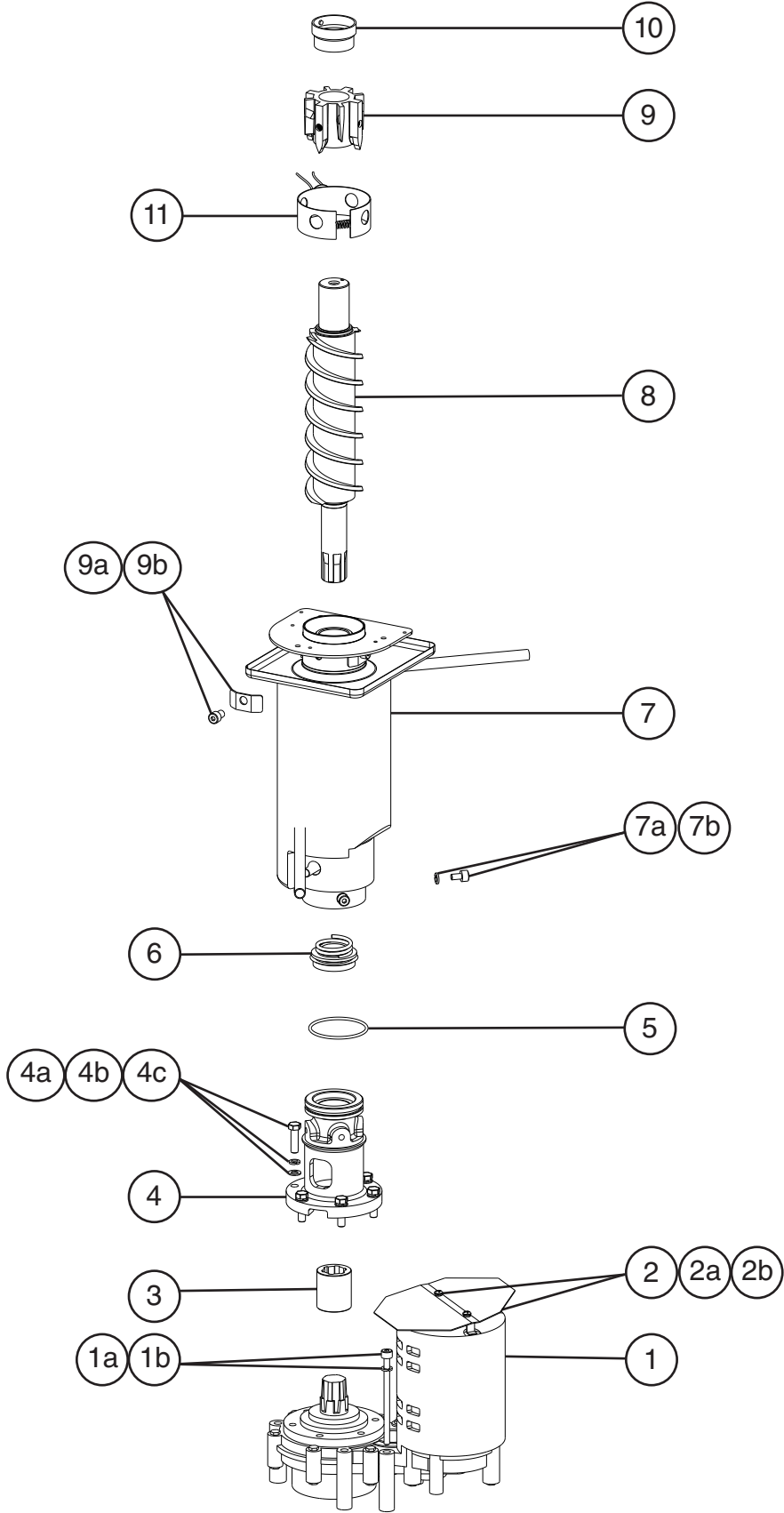

Title: B. Icemaking Unit Model: FD-1001M_H-C												
Index No.	Description	Material or Model Number	Part Number	U-0 to D-1	Required Number							
1	Gear Motor		4A2007-01	1								
1a	Socket Head Cap Screw		7S12-0811	3								
1b	Split Lock Washer		7L22-0800	3								
2	Gear Motor Barrier		4A4029-01	1								
2a	Truss Head Screw		7C32-0408	2								
2b	Rubber Washer		4A5268-01	2								
3	Spline Coupling		414137-01	1								
4	Housing		2A1977G01	1								
4a	Split Lock Washer		7L22-0800	6								
4b	Flat Washer		7W22-0800	6								
4c	Hex Head Bolt		7B02-0830	6								
5	O-Ring		4A4755-02	1								
6	Mechanical Seal		432492-01	1								
7	Evaporator	SP-5145	2A3312G01	1								
7a	Socket Head Cap Screw		7S12-0812	4								
7b	Split Lock Washer		7L22-0800	4								
8	Auger		120863G02	1								
9	Extruding Head		3A2176G01	1								
9a	Seal Bolt		P01768-01	4								
9b	Washer		427184-01	4								
10	Cutter		427183G01	1								
11	Evaporator Heater		4A2292-01	1								

C. Water Circuit
FD-1001M_H-C
U-0 to D-1

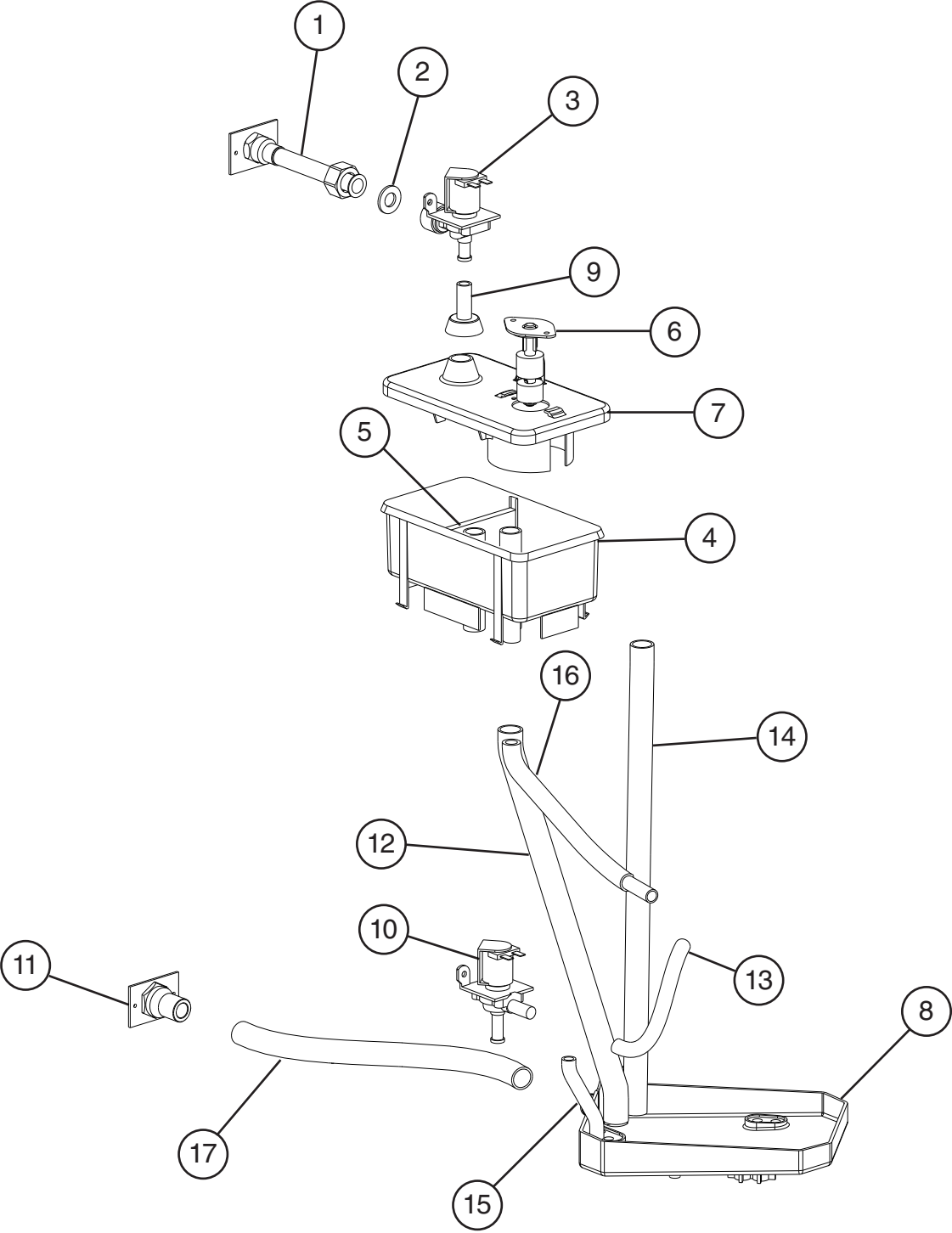

Title: C. Water Circuit Model: FD-1001M_H-C											
Index No.	Description	Material or Model Number	Part Number	Required Number							
				U-0 to B-0	B-1 to D-1						
1	Water Supply Pipe		4A4026G01	1	-						
			4A4026G02		1						
2	Washer		4A0867-01	1	1						
3	Inlet Water Valve		4A0865-01	1	-						
			4A5309-01		1						
4	Reservoir		2A0753-01	1	1						
5	Reservoir Separator		4A1255-01	1	1						
6	Float Switch		435490-01	1	1						
7	Reservoir Cover		214810-01	1	1						
8	Drain Pan (gear motor)		323765G02	1	1						
9	Reservoir Inlet		4A0869-01	1	1						
10	Drain Valve		4A2772-01	1	1						
11	Fitting		4A0776G01	1	1						
12	Hose	L=385 mm	7730-1822	1	1						
13	Silicone Hose	L=225 mm	7730I3896	1	1						
14	Hose	L=440 mm	7725-1923	1	1						
15	Hose	L=100 mm	7716-0913	1	1						
16	Reservoir Hose		4A1165-06	1	1						
17	Hose	L=295 mm	7716-2025	1	1						
	Hose Clamp	21-26 mm	4A2017-01	1	1						
	Hose Clamp	26-30 mm	4A2017-02	1	1						
	Hose Clamp	17-21 mm	4A2017-05	1	1						
	Hose Clamp	19-22 mm	4A2017-06	1	1						
	Hose Clamp	14-15 mm	4A2017-08	4	4						

D. Control Box Assembly
FD-1001M_H-C
 U-0 to D-1

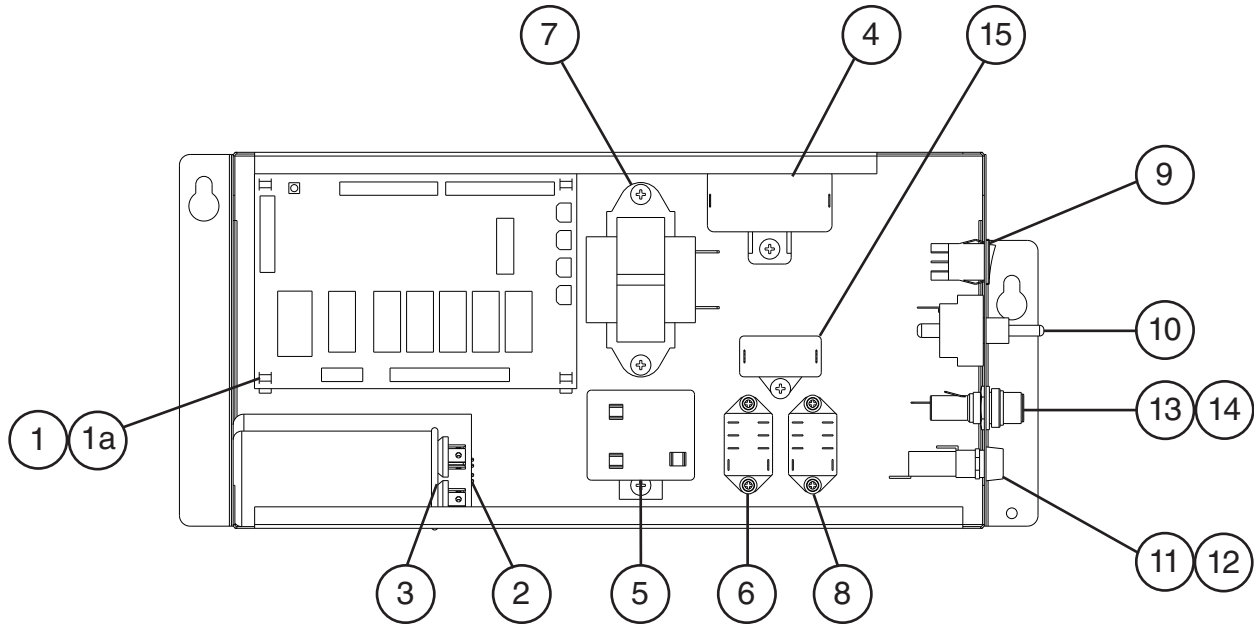

Title: D. Control Box Assembly		Model: FD-1001M_H-C		Required Number							
Index No.	Description	Material or Model Number	Part Number	U-0 to A-0	B-0 to D-1						
1	Control Board		2A4296-01	1	1						
1a	Control Board Support		4A0336-03	4	4						
2	Start Capacitor	108-130MFD, 330VAC	3A0076-22	1	1						
3	Run Capacitor	25MFD, 440VAC	3A2005-10	1	1						
4	Gear Motor Capacitor	24MFD, 250VAC	4A2273-01	1	1						
5	Start Relay		4A1107-07	1	1						
6	Gear Motor Relay	120VAC	406132-07	1	1						
7	Control Transformer		4A0557-01	1	1						
8	Curcuit Protect Relay	220/240VAC	418271-05	1	1						
9	Control Switch (rocker)		4A0558-01	1	1						
10	Power Switch (toggle)		4A2332-01	1	1						
11	Fuse	AGC-1A, 250VAC	4A0893-01	1	1						
12	Fuse Holder		4A3449-01	1	-						
			4A3449-02		1						
13	Fuse	GMD-3A, 250VAC Slow Blow	4A0893-06	3	3						
14	Fuse Holder		4A5443-01	1	1						
15	Fan Motor Capacitor	FD-1001MAH-C 5MFD, 250VAC	443192-02	1	1						

E. Accessories & Labels

FD-1001M_H-C

U-0 to D-1

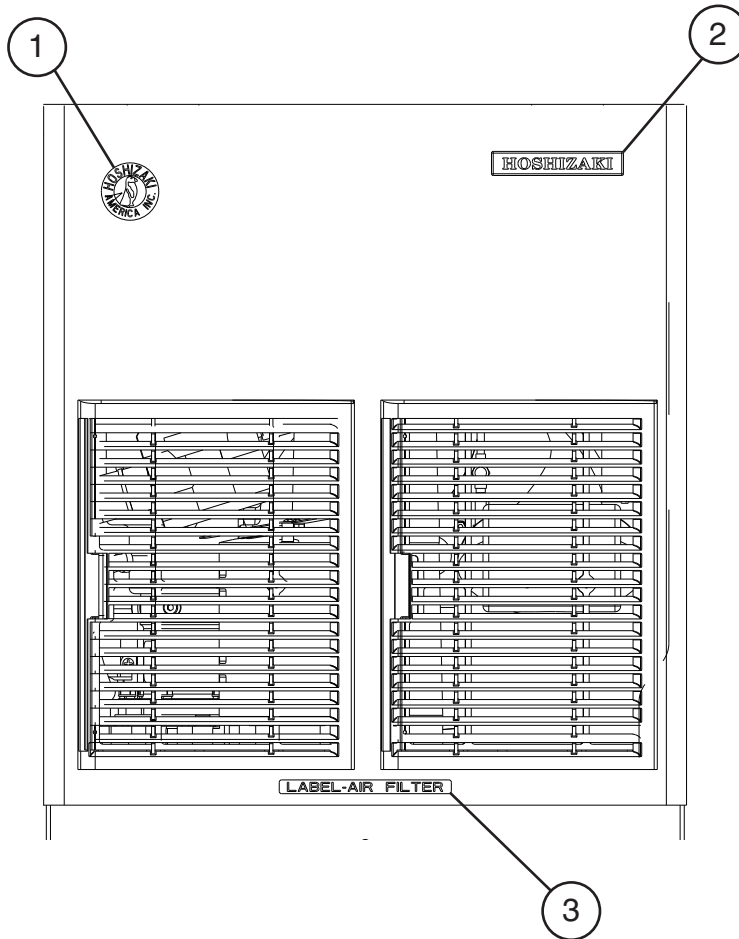

Title: E. Accessories & Labels Model: FD-1001M_H-C										
Index No.	Description	Material or Model Number	Part Number	Required Number						
				U-0 to C-0	C-1 to D-1					
1	Label-Penguin		456246-01	1	1					
2	Emblem		4A0560-01	1	1					
3	Air Filter Label		426177-01	1	-					
4	Universal Brace		4A0363-01	2	2					
4a	Hex Bolt	5x12, SS	7B02-0512	2	2					