



# HOSHIZAKI

## Parts List

Professional Series  
Refrigerated Kitchen Equipment

Models  
FHI-SSB(-HD)



[hoshizakiamerica.com](http://hoshizakiamerica.com)

Number: 71224  
Issued: 3-8-1999  
Revised: 12-21-2016

## CONTENTS

Auxiliary Codes.....	3
Note About Ordering Parts .....	3
A. Main Assembly .....	4
B. Refrigeration Circuit.....	6
C. Body-Final .....	9
FH1-SSB .....	9
FH1-SSB-HD .....	11
D. Control Box Assembly.....	13
E. Body-Prefinal .....	14
F. Door-Right Hinged.....	16
Full Solid: FH1-SSB .....	16
G. Door-Right Hinged .....	18
Upper Right (UR) Half Solid: FH1-SSB-HD .....	18
H. Door-Right Hinged.....	20
Lower Right (LR) Half Solid: FH1-SSB-HD.....	20
J. Horizontal Mullion.....	22
K. Air Top Distributor Assembly .....	23
L. Accessories & Labels.....	24

## Auxiliary Codes

### FH1-SSB

H-0	May 1998
J-0	March 1999
J-1	September 1999
J-2	October 1999
K-0	December 1999
K-1	June 2000
L-5	April 2001
M-5	February 2002
M-6	March 2002
M-7	August 2002
N-5	December 2002
N-6	January 2003
P-5	December 2003
P-6	March 2004
P-7	November 2004
Q-5	December 2004
R-5	December 2005
S-6	February 2007
T-5	January 2008
T-6	May 2008
T-7	September 2008
U-5	January 2009
V-5	January 2010
A-5	January 2011
B-5	January 2012
C-5	January 2013
D-5	January 2014
E-5	January 2015
F-5	January 2016

### FH1-SSB-HD

H-0	September 1998
J-0	January 1999
J-1	September 1999
J-2	October 1999
K-0	December 1999
K-1	June 2000
L-5	September 2001
M-6	April 2002
M-7	September 2002
N-6	March 2003
P-6	March 2004
Q-5	January 2005
R-5	December 2005
S-5	January 2007
S-6	March 2007
T-5	March 2008
U-5	November 2009
V-5	January 2010
A-5	February 2011
B-5	July 2012
C-5	February 2013
D-5	January 2014
E-5	January 2015
F-5	April 2016

## Auxiliary Code Breakdown

The auxiliary code is the first two characters in the serial number. The first character indicates the year. Years progress or regress in alphabetical order. The series runs from "A" through "V" and the letters "I" and "O" are skipped. The second character indicates significant part changes within a year. Base is "5" and this number advances for each change. In cases where there is a letter in parentheses, this designates the month. This is the last character in the serial number. The series runs from "(A)" through "(M)" and the letter "(I)" is skipped. This designation is only included when identifying a parts change within an auxiliary code.

## Note About Ordering Parts

Most assemblies cannot be ordered as complete units; parts in the assemblies generally must be ordered separately.

**A. Main Assembly**  
**FH1-SSB(-HD)**  
 H-0 to F-5

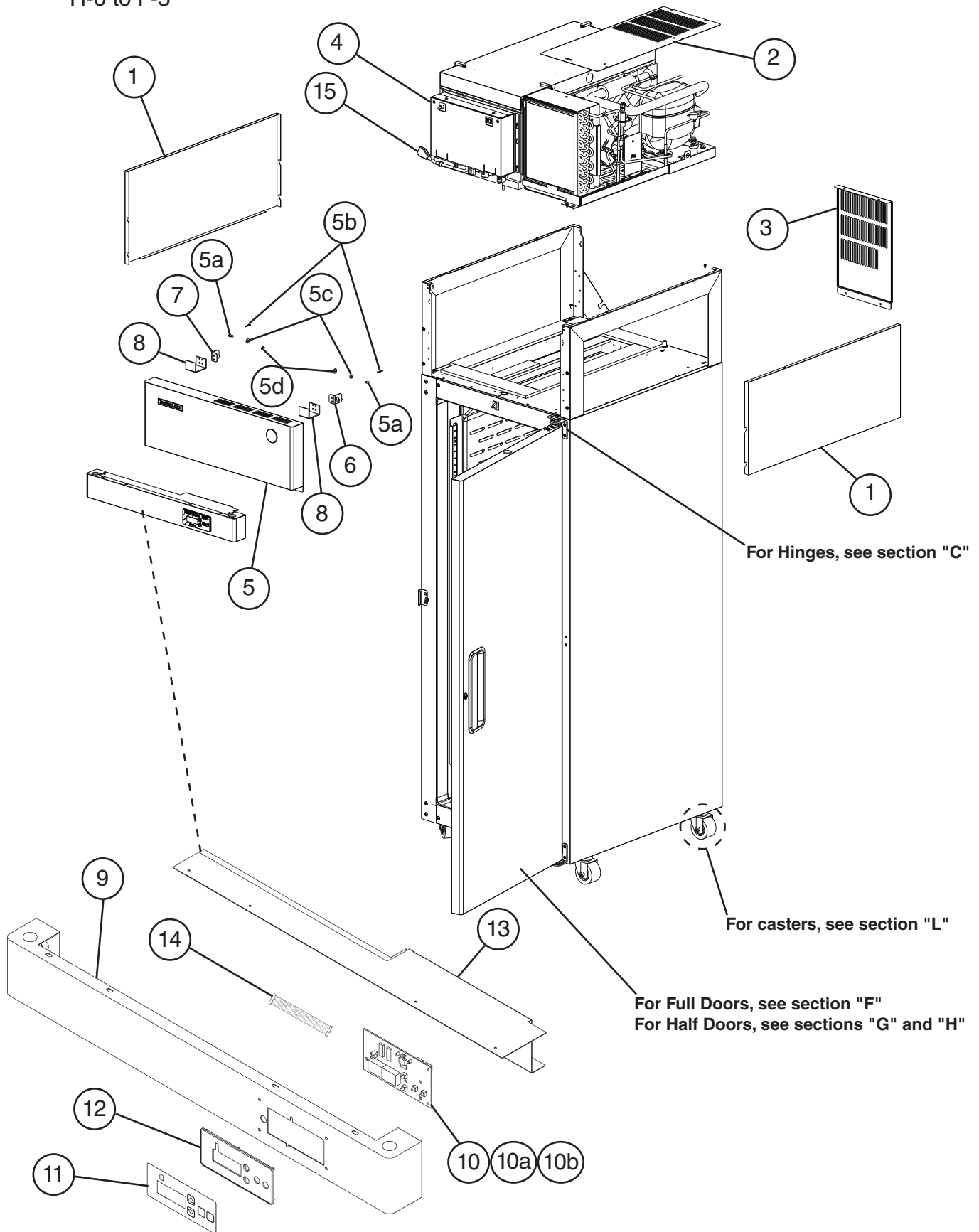

Title: A. Main Assembly Model: FH1-SSB(-HD)													
Index No.	Description	Material or Model Number	Part Number	Required Number									
				H-0 to K-1	L-5 to M-6	M-7 to N-5	N-6 to S-5	S-6 to F-5					
1	Upper Side Panel		2A0615-02	2	-								
			2A1800-01		2	2	2	2					
2	Top Cover		2A0955-01	1	1	-							
			2A2751-01			1	1	-					
			2A2755-01					1					
3	Rear Cover		2A0956-01	1	1	-							
			2A2752-01			1	1	-					
			2A4261-01					1					
4	Control Box Cover		2A1031-01	1	1	1	1	1					
5	Front Panel		1A0119-01	1	-								
		Hinged	1A0624-01		1	1	1	1	1				
5a	Clevis Pin		8907-0102		1	1	1	1					
5b	Cotter Pin		8907-0103		1	1	1	1					
5c	Flat Washer		4A0665-03		1	1	1	1					
5d	Hinge Spacer		4A2473-01		1	1	1	1					
6	Front Panel Right Hinge		4A2154-01		1	1	1	1					
7	Front Panel Left Hinge		4A2153-01		1	1	1	1					
8	Hinge Channel		4A2170-01	2	2	2	2	2					
9	Control Panel (Painted)		3A0914G01	1	-								
			1A0625G01		1	1	-						
	Control Panel		1A0760-01				1	1					
10	Display Board		2A0883-01	1	1	1	1	1					
10a	Nylon Screw		4A1397-01	4	4	4	4	4					
10b	Palnut		4A1398-01	6	6	6	6	6					
11	Display Label		4A1558-02	1	1	1	-						
			3A2850-02				1	-					
			3A5788-02					1					
12	Display Board Mount		3A0823-01	1	1	1	1	1					
13	Wire Cover		2A1033-01	1	1	1	1	1					
14	Ribbon Cable		4A1106-01	1	1	1	1	1					
15	Power Cord		4A0520-01	1	1	1	1	1					

**B. Refrigeration Circuit**  
**FH1-SSB(-HD)**  
 H-0 to F-5

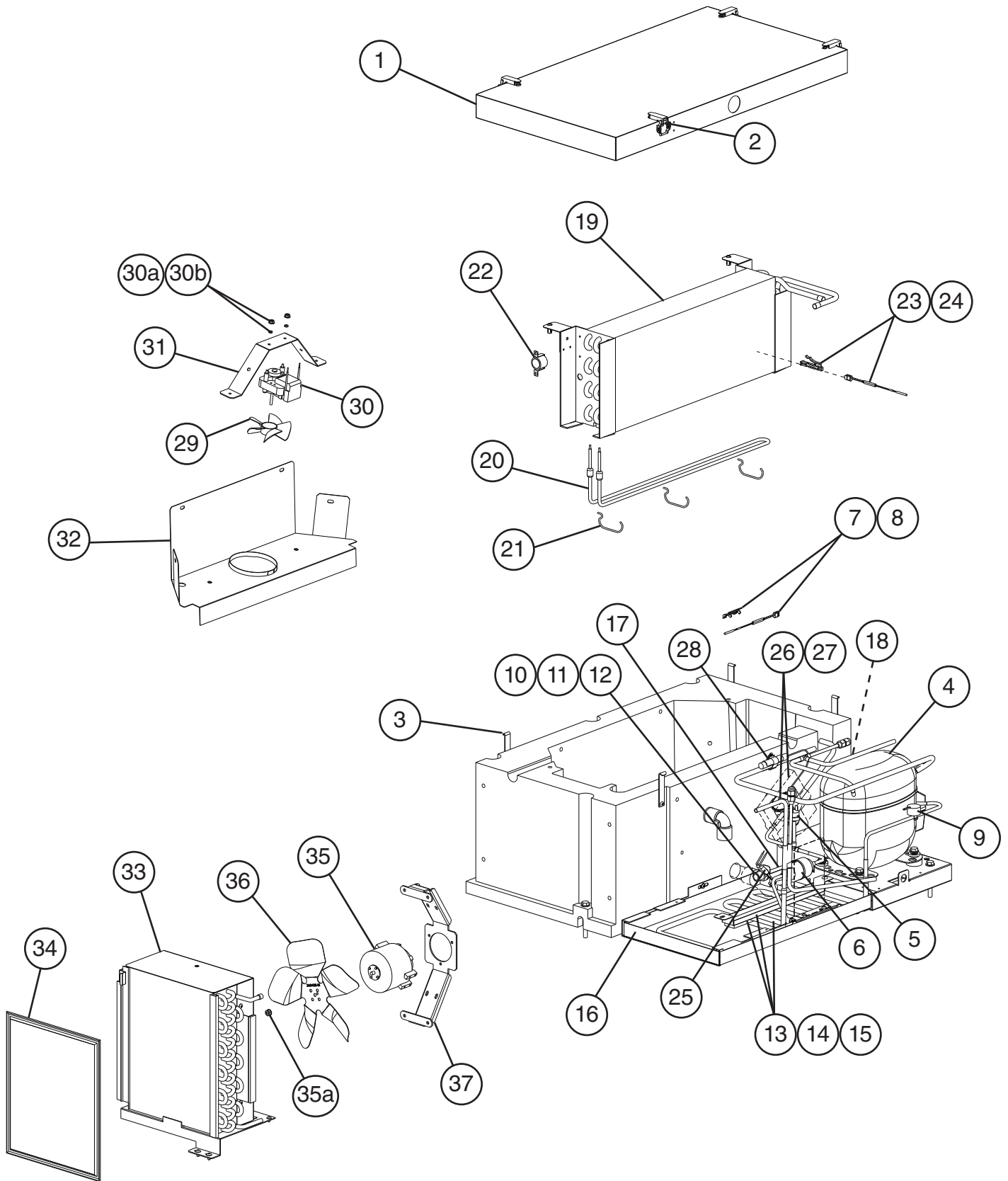

Title: B. Refrigeration Circuit Model: FH1-SSB(-HD)													
Index No.	Description	Material or Model Number	Part Number	Required Number									
				H-0 to K-1	L-5 to M-5	M-6 to N-5	N-6 to P-5	P-6 to S-5	S-6 to U-5	V-5 to A-5	B-5 (A) to B-5 (E)	B-5 (F) to F-5	
1	Evaporator Case Cover		2A0428G01	1	1	1	-						
			2A2726G01				1	1	1	1	1	-	
			2A4376G01									1	
2	Draw Latch		4A1710-01	4	4	4	-						
			4A3988-01				4	4	4	4	4	4	
3	Catch Latch		4A3987-01				4	4	4	4	4	4	
4	Compressor		2A0937-01	1	1	1	1	1	-				
			4A3815-01						1	1	1	1	
5	High-Pressure Switch		3A0335-02	1	1	-							
			4A2516-02			1	1	1	1	1	1	1	
6	Drier		4A0924-01	1	1	1	1	1	1	1	1	1	
7	Cabinet Thermistor		4A1429-01	1	1	1	1	1	1	1	1	1	
8	Thermistor Bracket		433920-01	1	1	1	1	1	1	1	1	1	
9	Clean Filter Thermostat		4A0484-01	1	1	1	1	1	1	1	1	1	
10	Drain Overflow Fitting		4A0664-01	1	1	-							
			4A2182-01			1	1	1	1	1	1	1	
11	Drain Washer		4A0665-01	1	1	-							
	Rubber Gasket		413854-03			1	1	1	1	1	1	1	
12	Drain Fitting Nut		4A0666-01	1	1	-							
13	Condensate Coated Coil		4A1362G01	1	1	-							
	Condensate Coil		3A1644-01			1	1	1	1	1	1	1	
14	Condenser Coil Gasket		4A0455-03	1	1	1	1	1	1	1	1	1	
15	Condensate Coil Strap		3A0232-03	1	1	1	1	1	1	1	1	1	
16	Evaporator Drain Pan		2A0616-02	1	1	-							
			2A2760-01			1	1	1	1	1	1	1	
17	Silicone Hose	L=300 mm	773013812	1	1	1	1	1	1	1	1	1	
18	Tubing Elbow		4A0711-01	1	1	1	1	1	1	1	1	1	
<b>Evaporator Assembly</b>													
19	Evaporator		2A0781-01	1	1	1	1	1	1	1	1	1	
20	Defrost Heater	309W, 115VAC	3A0846-01	1	1	1	1	1	1	1	1	1	
21	Defrost Heater Support		4A2506-01	3	3	3	3	3	3	3	3	3	
22	Defrost Thermostat		4A0954-01	1	-								
			4A0954-02		1	1	1	1	1	1	1	1	
23	Defrost Thermistor		4A1428-01	1	1	1	1	1	1	1	1	1	
24	Thermistor Clip		320418-01	1	1	1	1	1	1	1	1	1	
25	Evaporator Drain Heater	10W, 115VAC	4A2975-01					1	1	1	1	1	
26	Thermostatic Expansion Valve		4A1135-01	1	1	1	1	1	-				
			4A4196-01						1	1	1	1	
27	Thermostatic Expansion Valve Cover		4A4646-01	1	1	1	1	1	1	1	1	1	
28	Thermostatic Expansion Valve Holder		3A0107-01	1	1	1	1	1	1	1	1	1	

Title: B. Refrigeration Circuit Model: FH1-SSB(-HD)												
Index No.	Description	Material or Model Number	Part Number	Required Number								
				H-0 to K-1	L-5 to M-5	M-6 to N-5	N-6 to P-5	P-6 to S-5	S-6 to U-5	V-5 to A-5	B-5 (A) to B-5 (E)	B-5 (F) to F-5
<b>Evaporator Fan Assembly</b>												
29	Evaporator Fan Blade		4A2802-01	Note: For auxiliary codes prior to M-6, order HS-5039 and replace parts 29-32.	1	1	1	1	1	1	-	
			4A5437-01								1	1
30	Evaporator Fan Motor		4A2563-01		1	1	1	1	1	1	-	
			4A4942-01								1	1
30a	Hex Nut	8-32	7N0210832		2	2	2	2	2	2	2	2
30b	Split Lock Washer	8-32	7L2210832		2	2	2	2	2	2	2	2
31	Fan Motor Bracket		3A2480-01		2	2	2	2	2	2	-	
			3A6848-01								2	2
32	Evaporator Fan Shroud		2A2565G01		1	1	-					
			2A2565G02				1	1	1	1	-	
			3A6851G01							1	1	
<b>Condenser and Condenser Fan Assembly</b>												
33	Condenser		2A0782-01	1	1	1	1	1	1	1	1	1
34	Condenser Filter		3A0277-01	1	1	1	1	1	1	1	1	1
35	Condenser Fan Motor		4A0815-01	1	1	1	1	1	-			
		FM116A	4A3158-01						1	-		
			4A0815-01							1	1	1
35a	Self Locking Nut	8-32	7N2110832							4	4	4
36	Condenser Fan Blade		3A0608-01	1	1	1	1	1	-			
			4A1865-01						1	-		
			3A0436-01							1	1	1
37	Condenser Fan Motor Bracket		3A0457-01	1	1	1	-					
			3A1564-01				1	1	1	1	1	1



**C. Body-Final**  
**FH1-SSB**  
H-0 to F-5

For Full Doors, see section "F"

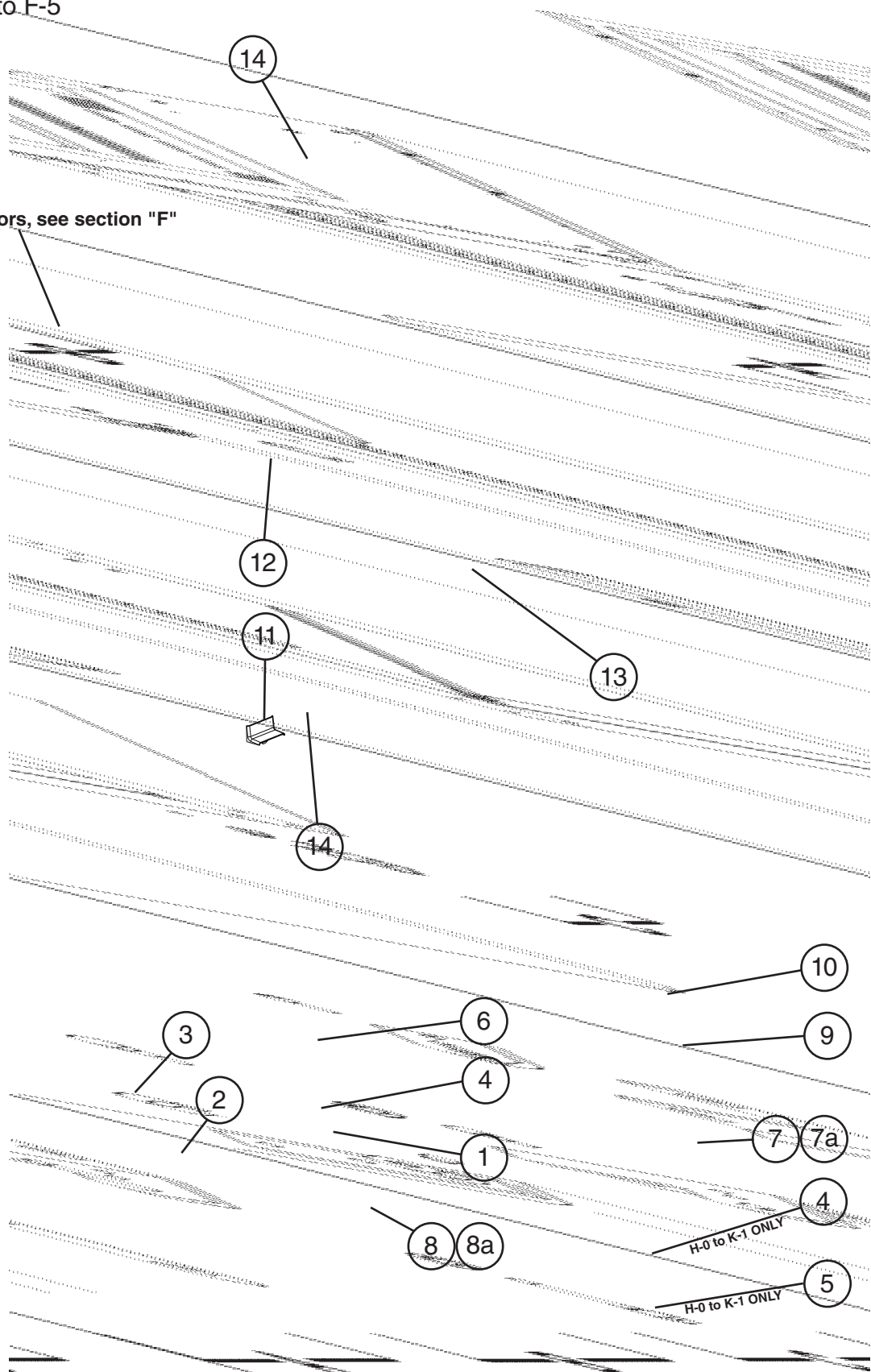

**Title: C. Body-Final Model: FH1-SSB**

Index No.	Description	Material or Model Number	Part Number	Required Number									
				H-0 to K-1	L-5 to U-5 (E)	U-5 (F) to F-5							
1	Hinge Stop Pin		4A0444-01	1	-								
			4A2180-01		1	1							
2	Hinge Tension Screw		4A0446-01	1	1	1							
3	Hinge Bushing Cover		4A0445-01	1	1	1							
4	Hinge Lock Washer		4A0553-01	2	1	1							
5	Bottom Hinge Pivot Pin		4A0443-01	1	-								
6	Top Hinge Pivot Pin		4A0442-01	1	-								
			4A2179-01		1	1							
7	Lower Right (LR) Door Hinge Bracket		3A1626-01	1	1	1							
7a	Countersunk Screw	5x20, SS	7C42-0520	3	3	3							
8	Upper Right (UR) Door Hinge Bracket		3A1580-01	1	1	1							
8a	Countersunk Screw	5x20, SS	7C42-0520	3	3	3							
9	Stop Plate HInge		4A0441-01	1	1	1							
10	Stop Plate Screw		4A0483-01	1	1	1							
11	Corner Cover		3A0221-01	4	-								
			3A1751-01		4	4							
12	Strike Plate		4A0470-01	1	1	-							
			4A4587-01			1							
13	Filler T2 Screw	4x8, SS	7P32-0408	2	2	2							
14	Filler Truss Head Screw	5x10, SS	7C32-0510	6	6	6							

**C. Body-Final**  
**FH1-SSB-HD**  
H-0 to F-5

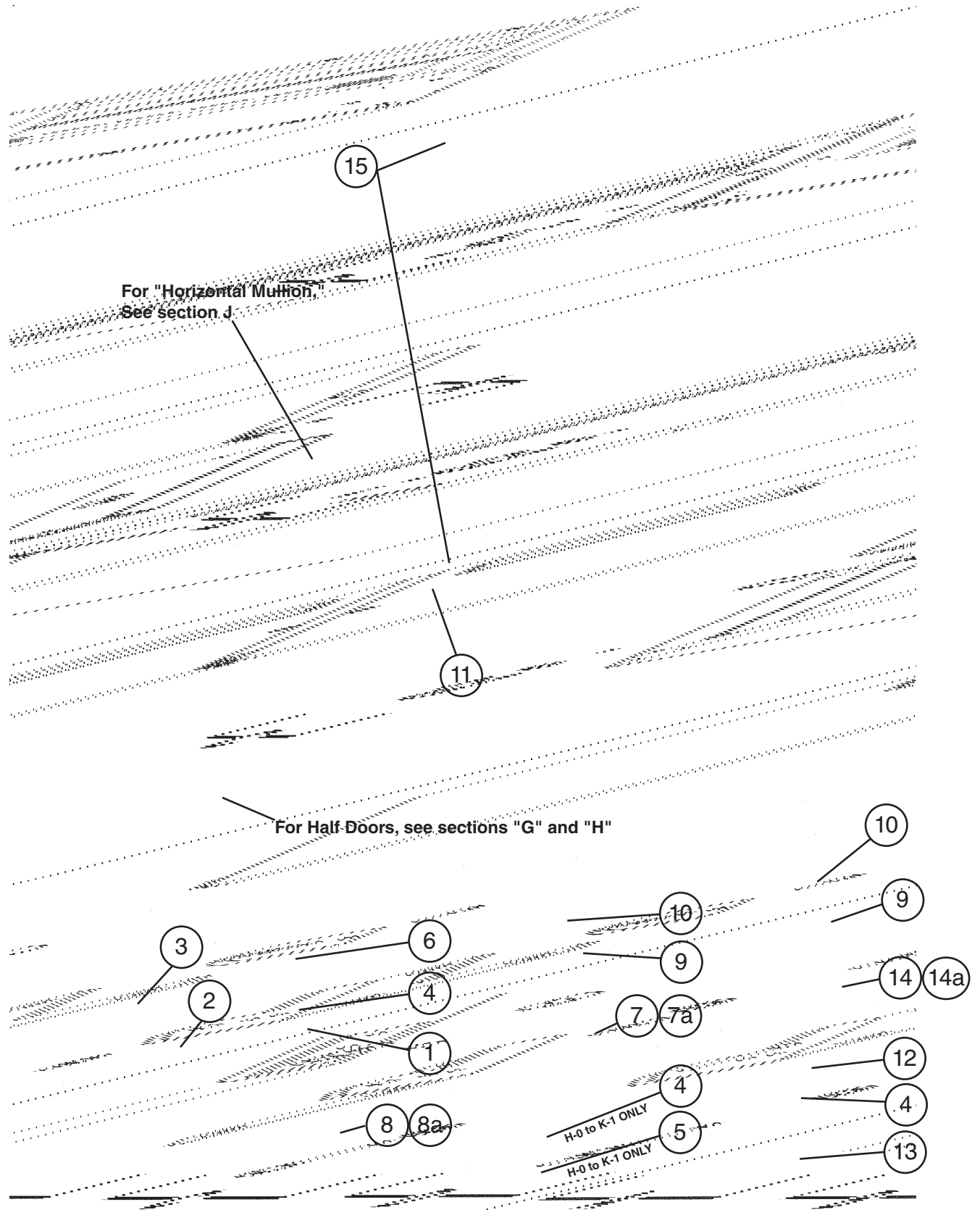

**Title: C. Body-Final Model: FH1-SSB-HD**

Index No.	Description	Material or Model Number	Part Number	Required Number									
				H-0 to K-1	L-5 to F-5								
1	Hinge Stop Pin		4A0444-01	1	-								
			4A2180-01		1								
2	Hinge Tension Screw		4A0446-01	2	2								
3	Hinge Bushing Cover		4A0445-01	2	2								
4	Hinge Lock Washer		4A0553-01	3	2								
5	Bottom Hinge Pivot Pin		4A0443-01	1	-								
6	Top Hinge Pivot Pin		4A0442-01	1	-								
			4A2179-01		1								
7	Lower Right (LR) Door Hinge Bracket		3A1626-01	1	1								
7a	Countersunk Screw	5x20, SS	7C42-0520	3	3								
8	Upper Right (UR) Door Hinge Bracket		3A1580-01	1	1								
8a	Countersunk Screw	5x20, SS	7C42-0520	3	3								
9	Stop Plate Hinge		4A0441-01	2	2								
10	Stop Plate Screw		4A0483-01	2	2								
11	Corner Cover		3A0221-01	8	-								
			3A1751-01		8								
12	Stop Pin		4A1734-01	1	1								
13	Pivot Pin		4A1735-01	1	1								
14	Center Door Hinge Bracket		3A1581-01	1	1								
14a	Countersunk Screw	5x20, SS	7C42-0520		3								
15	Filler Truss Head Screw	5x10, SS	7C32-0510	9	9								

# D. Control Box Assembly

## FH1-SSB(-HD)

H-0 to F-5

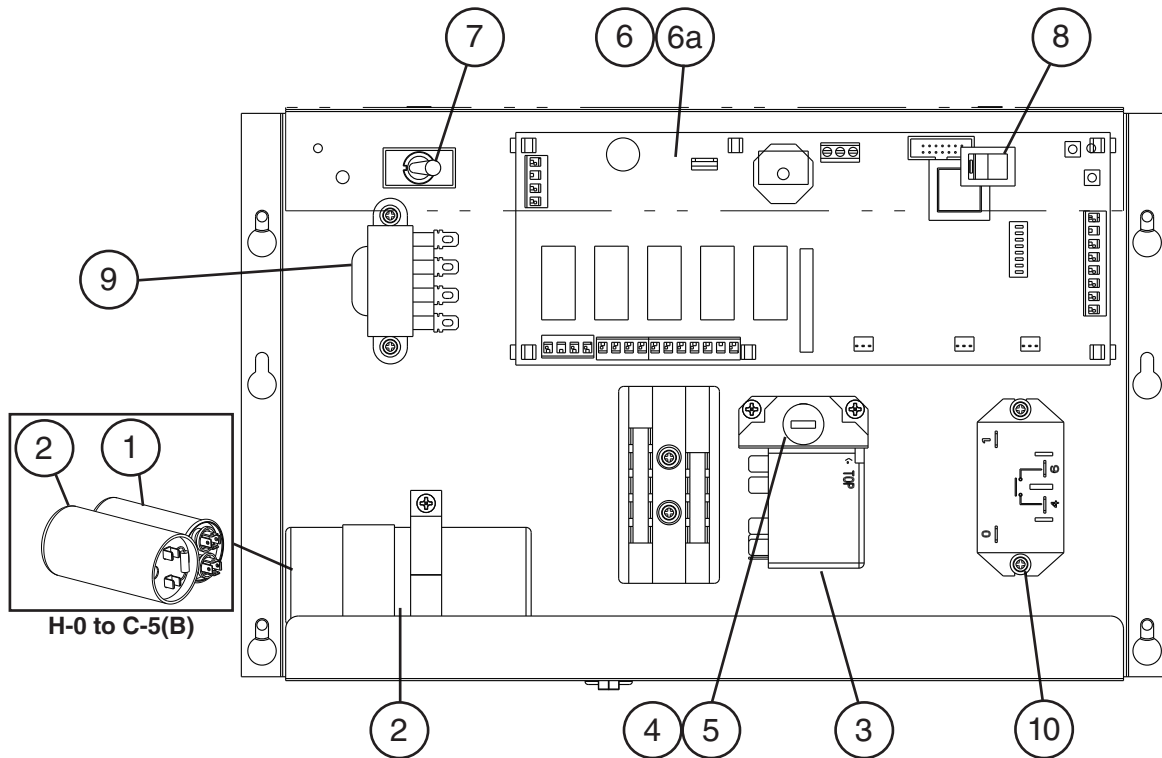

Title: D. Control Box Assembly Model: FH1-SSB(-HD)				Required Number								
Index No.	Description	Material or Model Number	Part Number	H-0	J-0 to K-1	L-5	M-5 to P-5	P-6 to S-5	S-6 to C-5 (B)	C-5 (C) to F-5		
				1	Run Capacitor	15MFD, 370VAC	439943-04	1	1	1	-	-
2	Start Capacitor	270-324MFD, 165V	3A2005-08	1	1	1	1	1	-	-		
		369-451MFD, 125VAC	4A2134-02						1	1		
3	Start Relay		4A1308-01	1	-							
			4A1107-03		1	1	1	1	-	-		
			4A3683-01						1	1		
4	Fuse Holder		4A0892-01				1	1	1			
5	Fuse	AGC-5A, 250VAC	4A0893-09				1	1	1			
6	Control Board		2A2862-24	1	1	1	1	1	1	1		
6a	Control Board Support		4A0336-03	4	4	4	4	4	4	4		
7	Toggle Switch		4A0424-01	1	1	1	1	1	1	1		
8	Rocker Switch		4A0418-01	1	1	1	1	1	1	1		
9	Control Transformer		3A0172-01	1	1	-						
			3A1759-01			1	1	1	1	1		
10	Compressor Relay		4A1307-01	1	1	1	1	1	1	-		
			4A3140-01								1	

**E. Body-Prefinal**  
**FH1-SSB(-HD)**  
 H-0 to F-5

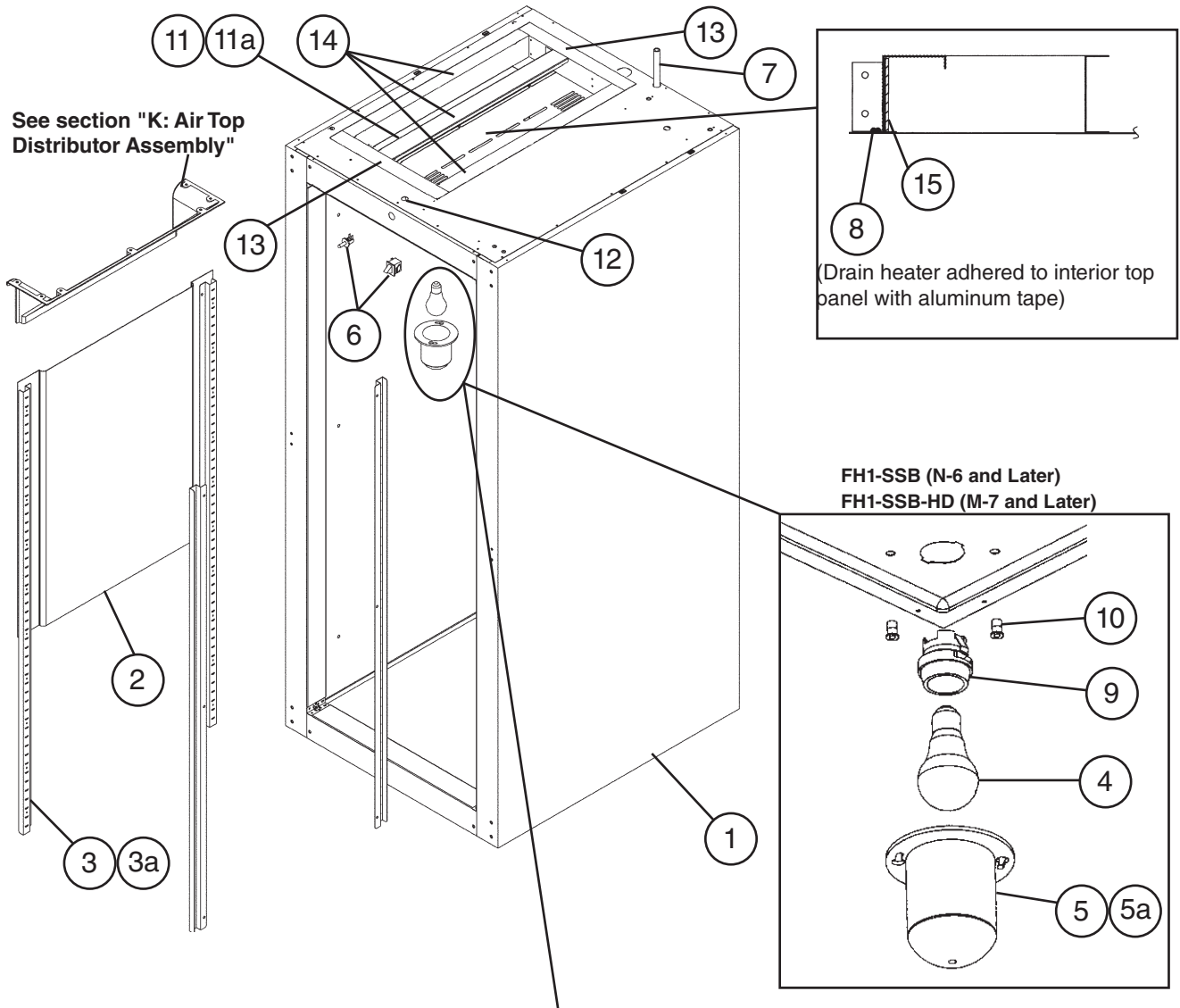

**FH1-SSB (M-7 and Earlier)**  
**FH1-SSB-HD (M-6 and Earlier)**

The santoprene light socket was changed to a porcelain lampholder at N-6 for the FH1-SSB and M-7 for the FH1-SSB-HD. This change is non-interchangeable. If the light socket is not operating on a unit with a santoprene light socket, order **HS-3554 - Lampholder Conversion Kit**.

**Note:**

Parts 4, 5 and 5a are not included in HS-3554; they are shown for reference only.

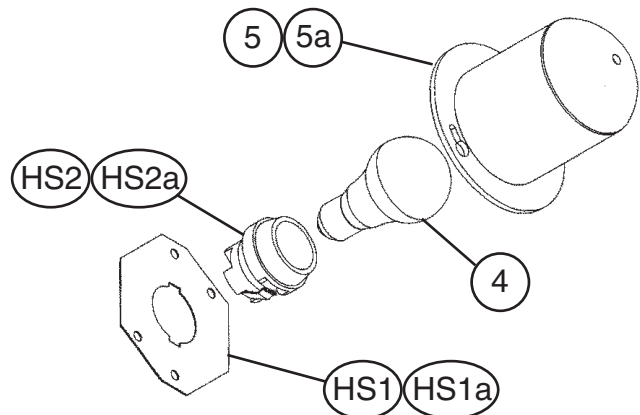

Title: E. Body-Prefinal Model: FH1-SSB(-HD)												
Index No.	Description	Material or Model Number	Part Number	Required Number								
				H-0	J-0	J-1	J-2 to M-6	M-7 N-5	N-6 P-5	P-6 to F-5		
1	Cabinet	FH1-SSB	1A0173G01	1	1	1	1	1	-			
			1A1391G01					1	1			
		FH1-SSB-HD	1A0353G01	1	1	1	1	-				
			1A1697G01					1	1	1		
2	Bottom Air Distributor		2A0425-01	1	1	1	1	1	1	1		
3	Pilaster		3A0145-01	4	4	4	4	4	4	4		
3a	Truss Head Screw		7C32-0510	12	12	12	12	12	12	12		
4	Light Bulb	FH1-SSB	4A0437-01	1	1	1	1	1	-			
			4A2420-01					1	1			
		FH1-SSB-HD	4A0437-01	1	1	1	1	-				
			4A2420-01					1	1	1		
5	Light Shield		4A0465-01	1	1	1	1	1	1	1		
	Cheese Head Screw	5x12, SS	7C52-0512	2	2	2	2	2	2	2		
6	Door Switch	FH1-SSB	4A0487-01	1	-							
			3A1386-01		1	1	1	1	-			
			3A1826-01						1	1		
		FH1-SSB-HD	4A0487-01	2	-							
			3A1386-01		2	2	-					
			3A1826-01				2	2	2	2		
7	Vinyl Hose	L=1700 mm	7716-0913	1	-							
			773013812		1	1	1	1	1	1		
8	Drain Heater	25W, 115VAC	4A2975-03							1		
9	Lampholder	FH1-SSB	4A2862-01	Non-interchangeable				-	1	1		
		FH1-SSB-HD	4A2862-01	part. Order HS-3554 -				1	1	1		
10	Threaded Insert (special tool required)	FH1-SSB	4A0839-01	Lampholder				-				
		FH1-SSB-HD	4A0839-01	Conversion Kit.				-				
11	Air Divider		2A0199-21	1	1	1	1	1	1	1		
11a	T2 Screw	4x8, SS	7P32-0408	4	4	4	4	4	4	4		
12	Bushing		428394-04	2	2	2	-					
13	Gasket	L=375 mm	4A0414L01	1	2	2	-					
		L=400 mm	4A0414L03				2	2	2	2		
14	Gasket	L=575 mm	4A0414L01	4	3	3	-					
		L=577 mm	4A0414L03				3	3	3	3		
15	Plate		4A0758-01	1	1	1	1	1	1	1		

HS-3554 - Lampholder Conversion Kit												
Index No.	Description	Material or Model Number	Part Number	Required Number								
				FH1-SSB (M-7 and Earlier)				FH1-SSB-HD (M-6 and Earlier)				
HS1	Lampholder Mount Plate		4A2880-01	1								
HS1a	Cheese Head Screw		7C52-0512	2								
HS2	Lampholder		4A2862-01	1								
HS2a	Flag Terminal		8101-18FJ	2								

**F. Door-Right Hinged**  
**Full Solid: FH1-SSB**  
H-0 to F-5

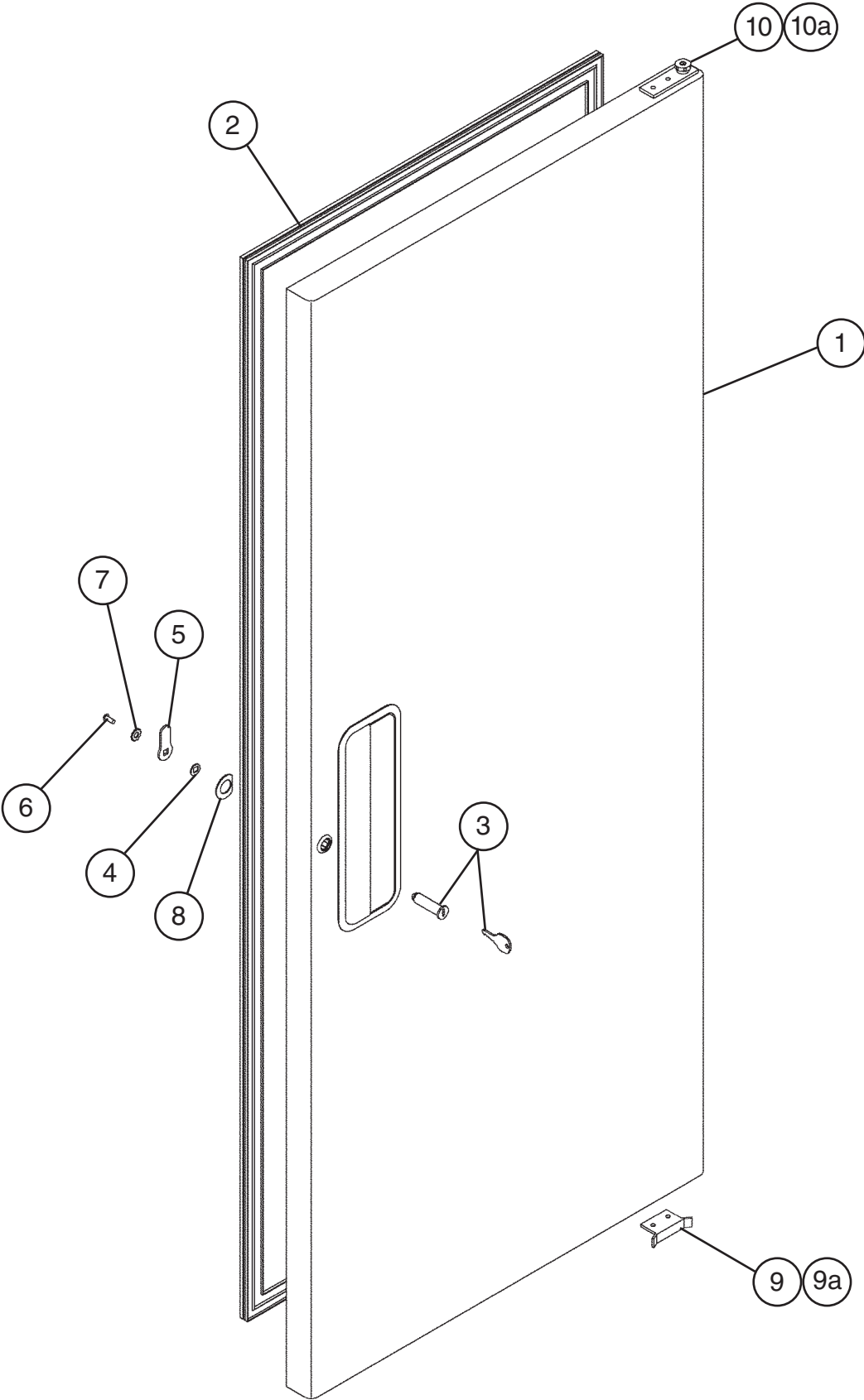



Title: F. Door-Right Hinged Model: Full Solid: FH1-SSB											
Index No.	Description	Material or Model Number	Part Number	Required Number							
				H-0	J-0 to K-1	L-5 to A-5 (H)	A-5 (J) to F-5				
1	Right Solid Door (includes item 2)	HS-3200	1A0318A03	1	1	1	-				
			2A6545G01				1				
2	Door Gasket		3A0273-01	1	1	1	-				
			2A5192-07				1				
3	Door Lock Tumbler (includes Key 4A0460-01)		4A0462-01	1	1	1	1				
4	Door Lock Stop Washer		4A0458-01	1	1	1	1				
5	Door Lock Cam		4A0228-01	1	1	1	1				
6	Door Lock Screw		4A0461-01	1	1	1	1				
7	Door Lock Washer		4A0459-01	1	1	1	1				
8	Door Lock Lock Washer		4A0670-01	1	1	1	1				
9	Door Stop		4A0351-01	1	1	-					
			4A1873-01			1	1				
9a	Countersunk Screw	5x20, SS	7C42-0520	2	-						
	Truss Head Screw	5x20, SS	7C32-0520		2	-					
10	Right Hinge Spring Cartridge		4A0438-01	1	1	1	1				
10a	Countersunk Screw	5x20, SS	7C42-0520	2	2	2	2				

**G. Door-Right Hinged**  
**Upper Right (UR) Half Solid: FH1-SSB-HD**  
H-0 to F-5

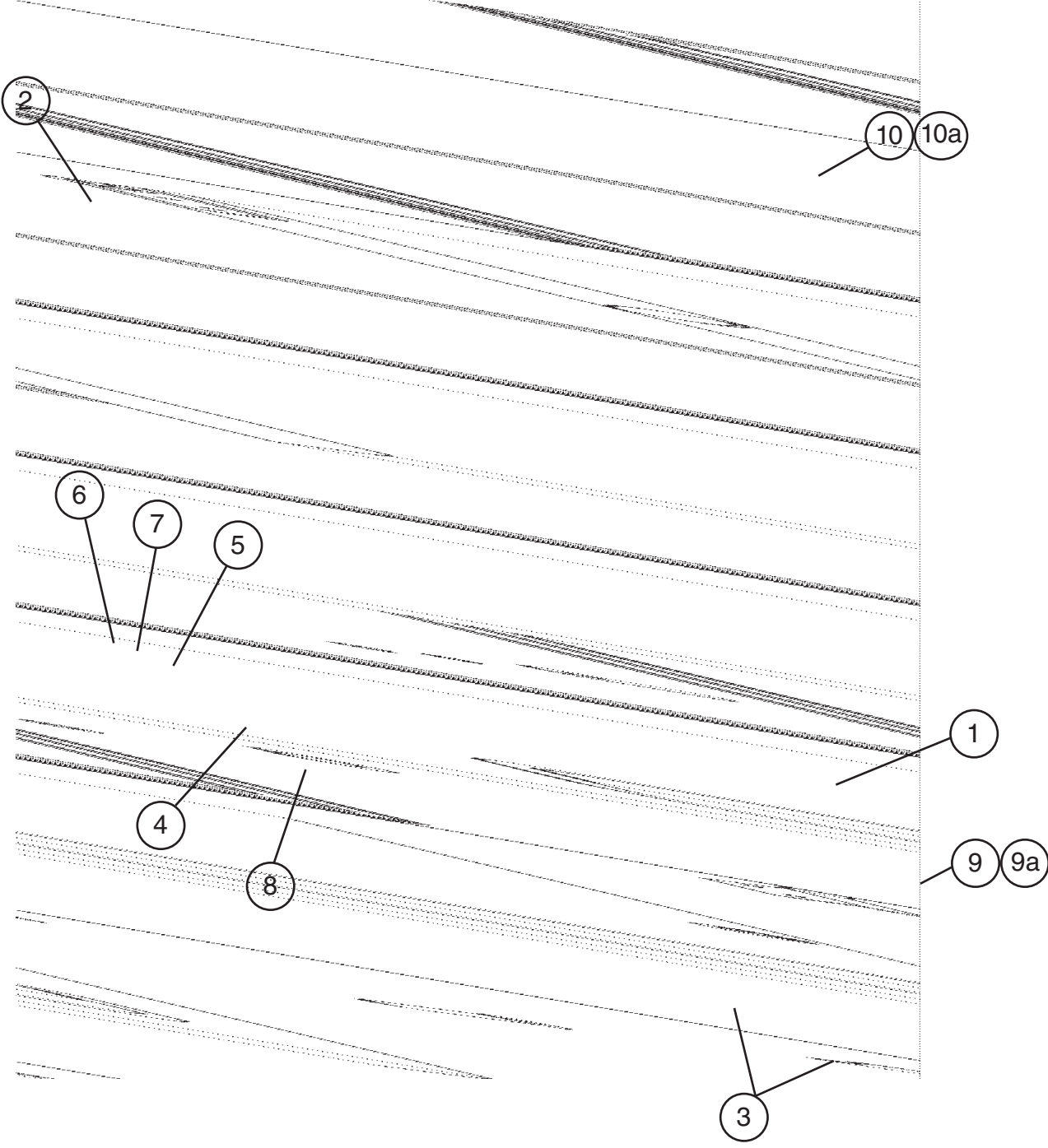

Title: G. Door-Right Hinged Model: Upper Right (UR) Half Solid: FH1-SSB-HD											
Index No.	Description	Material or Model Number	Part Number	Required Number							
				H-0	J-0 to K-1	L-5 to A-5 (H)	A-5 (J) to F-5				
1	Upper Right (UR) Door (includes item 2)	HS-3202	1A0326A03	1	1	1	-				
			2A6549G01				1				
2	Half Door Gasket		3A0273-02	1	1	1	-				
			2A5192-08				1				
3	Lock Tumbler (includes Key 4A0460-01)		4A0462-01	1	1	1	1				
4	Door Lock Stop Washer		4A0458-01	1	1	1	1				
5	Door Lock Cam		4A0228-01	1	1	1	1				
6	Door Lock Screw		4A0461-01	1	1	1	1				
7	Door Lock Washer		4A0459-01	1	1	1	1				
8	Door Lock Lock Washer		4A0670-01	1	1	1	1				
9	Door Stop		4A0351-01	1	1	-					
9a	Countersunk Screw	5x20, SS	7C42-0520	2	-						
	Truss Head Screw	5x20, SS	7C32-0520		2	-					
10	Right Hinge Spring Cartridge		4A0438-01	1	1	1	1				
10a	Countersunk Screw	5x20, SS	7C42-0520	2	2	2	2				

**H. Door-Right Hinged**  
**Lower Right (LR) Half Solid: FH1-SSB-HD**  
H-5 to F-5

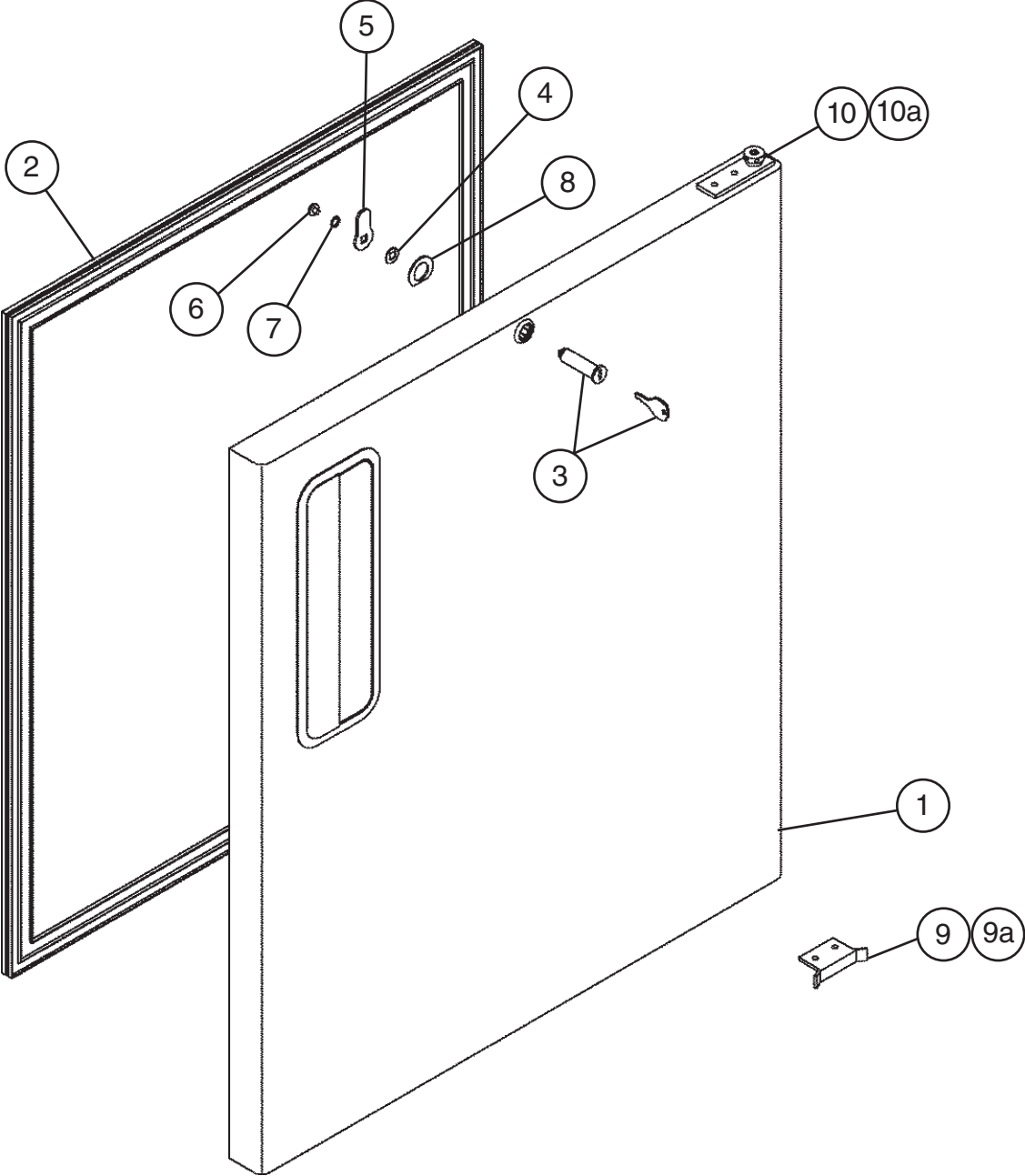

Title: H. Door-Right Hinged Model: Lower Right (LR) Half Solid: FH1-SSB-HD											
Index No.	Description	Material or Model Number	Part Number	Required Number							
				H-0	J-0 to K-1	L-5 to A-5 (H)	A-5 (J) to F-5				
1	Lower Right (LR) Door (includes item 2)	HS-3203	1A0324A03	1	1	1	-				
			2A6550G01				1				
2	Half Door Gasket		3A0273-02	1	1	1	-				
			2A5192-08				1				
3	Door Lock Tumbler (includes Key 4A0460-01)		4A0462-01	1	1	1	1				
4	Door Lock Stop Washer		4A0458-01	1	1	1	1				
5	Door Lock Cam		4A0228-01	1	1	1	1				
6	Door Lock Screw		4A0461-01	1	1	1	1				
7	Door Lock Washer		4A0459-01	1	1	1	1				
8	Door Lock Lock Washer		4A0670-01	1	1	1	1				
9	Door Stop		4A0351-01	1	1	-					
9a	Countersunk Screw	5x20, SS	7C42-0520	2	-						
	Truss Head Screw	5x20, SS	7C32-0520		2	-					
10	Right Hinge Spring Cartridge		4A0438-01	1	1	1	1				
10a	Countersunk Screw	5x20, SS	7C42-0520	2	2	2	2				

**J. Horizontal Mullion**  
**FH1-SSB-HD**  
H-0 to F-5

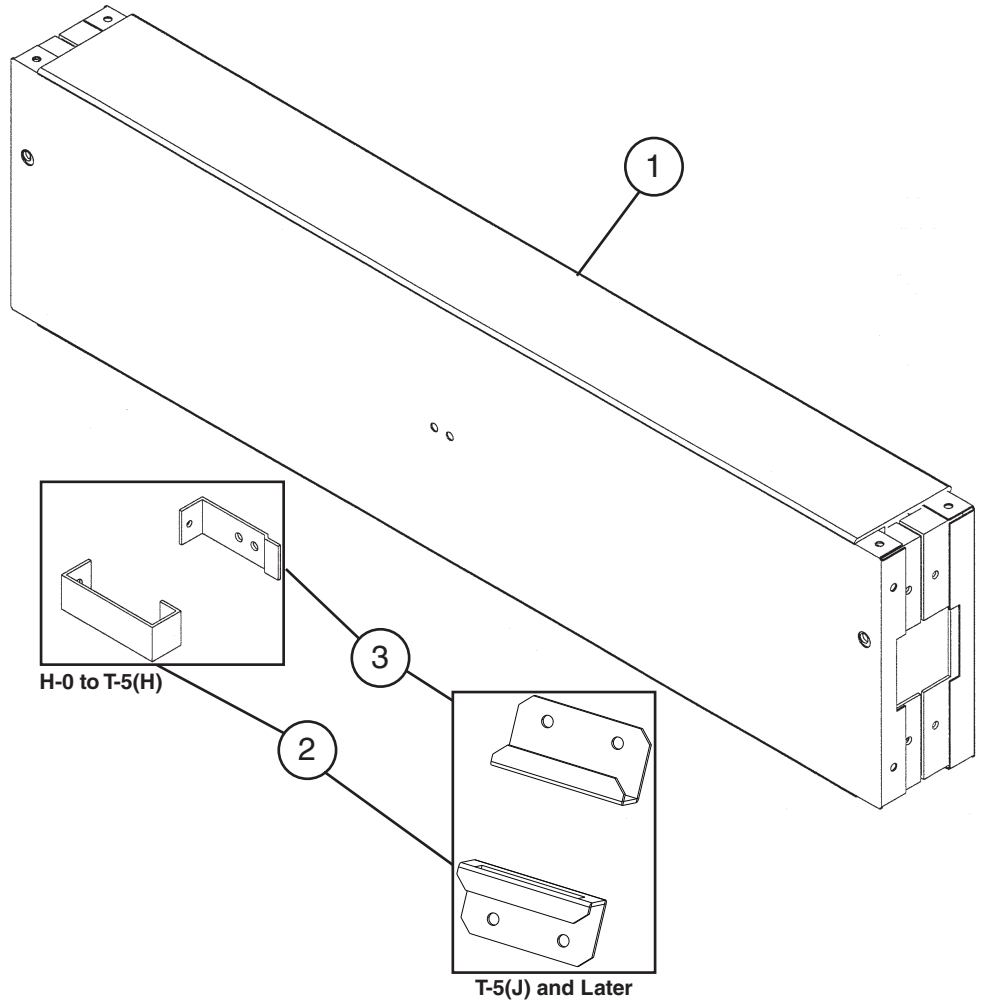

Title: J. Horizontal Mullion Model: FH1-SSB-HD											
Index No.	Description	Material or Model Number	Part Number	Required Number							
				H-0 to T-5 (H)	T-5 (J) to F-5						
1	Mullion	<b>FH1-SSB-HD</b>	2A1313G04	1	-						
			2A3917G01		1						
2	Front Strike Plate		4A0355-01	1	-						
			4A4587-01		1						
3	Base Strike Plate		4A0354-01	1	-						
			4A4587-01		1						

**K. Air Top Distributor Assembly**  
**FH1-SSB(-HD)**  
H-0 to F-5

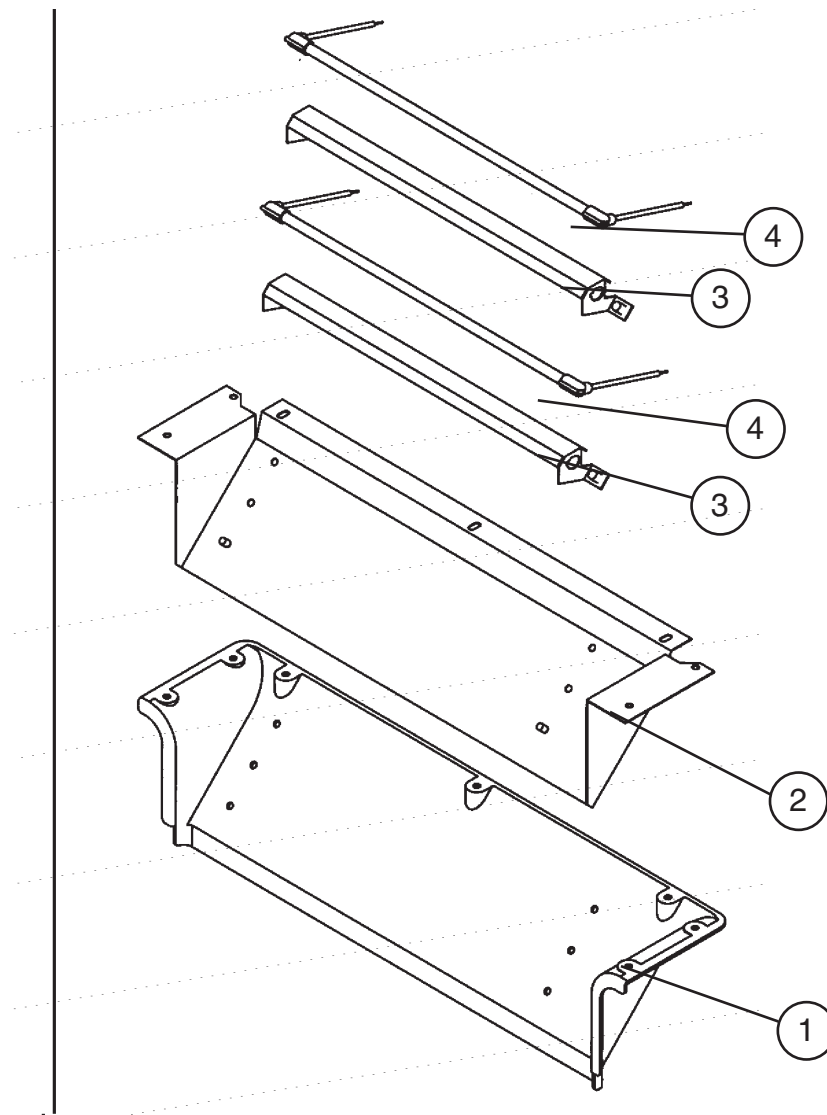

Title: K. Air Top Distributor Assembly		Model: FH1-SSB(-HD)		Required Number								
Index No.	Description	Material or Model Number	Part Number	H-0 to P-5	P-6	P-7 to F-5						
				1	Air Top Distributor		2A0610-01	1	-			
			2A0610-03		1	-						
			2A0610-04			1						
2	Duct Shield		2A3085-01		1	-						
			2A3392-01			1						
3	Heater Supply Bracket		3A3096G01		2	2						
4	Glass Tube Heater		3A2335-02		2	2						

**L. Accessories & Labels**  
**FH1-SSB(-HD)**  
H-0 to F-5

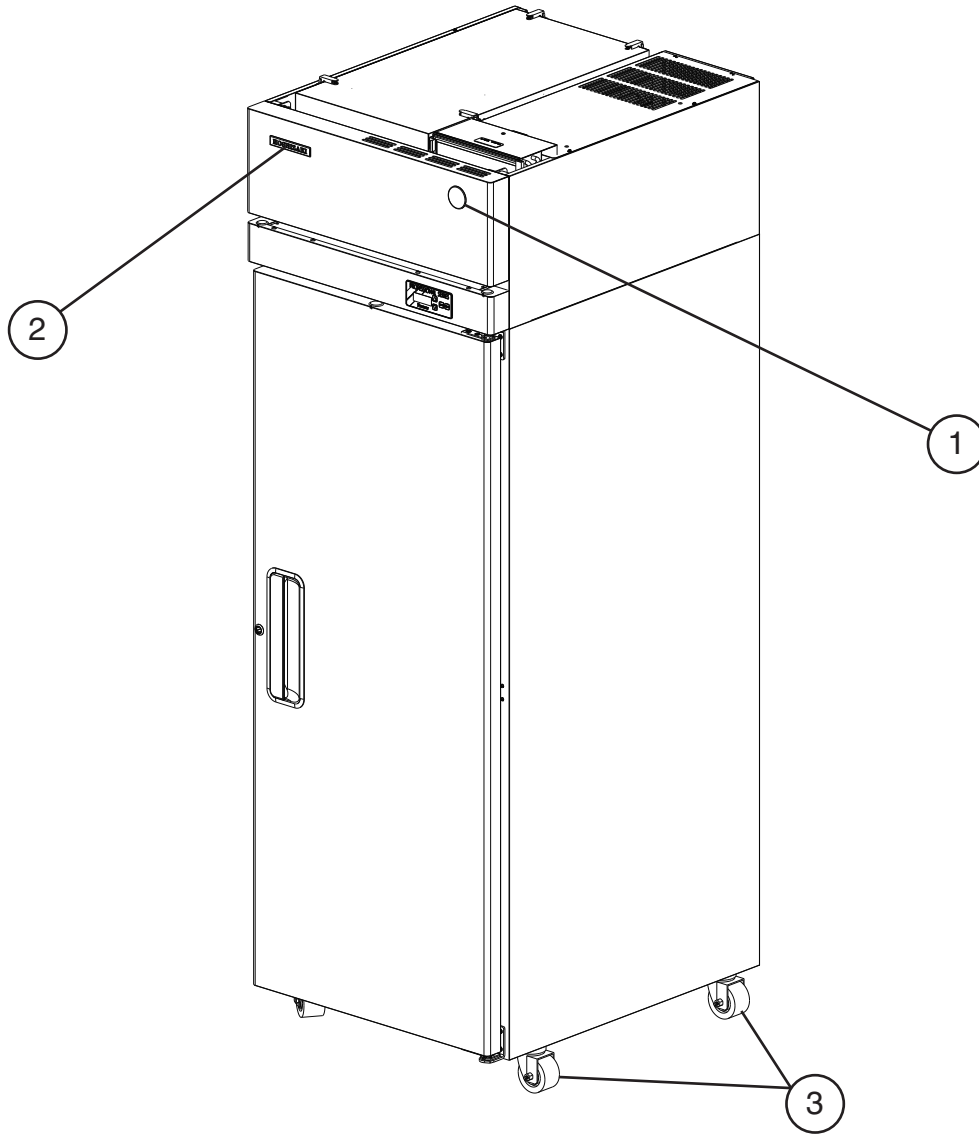

Title: L. Accessories & Labels		Model: FH1-SSB(-HD)		Required Number							
Index No.	Description	Material or Model Number	Part Number	H-0 to A-5 (G)	A-5 (H) to F-5						
				1	Label-Penguin-HA(L)		456246-02	1	1		
2	Emblem-Hoshizaki		4A0560-01	1	1						
3	Leg (box of 4)	HS-3512	4A0930-01	1	-						
	Caster	Non-Locking	4A1347-01		2						
		Locking		4A1347-02		2					
4	Shelf (3 pack)	HS-3508	3A1416A03	1	1						