



HOSHIZAKI

Parts List

Modular Crescent Cuber

Models

KM-1100MAH, MWH, MRH



hoshizakiamerica.com

Number: 71360
Issued: 2-10-2015
Revised: 10-25-2017

CONTENTS

Auxiliary Codes.....	3
Note About Ordering Parts	3
A. Main Assembly & Refrigeration Circuit	4
KM-1100MAH	4
KM-1100MWH	6
KM-1100MRH	8
B. Water Circuit	10
C. Control Box Assembly	13
D. Accessories & Labels	14

Auxiliary Codes

KM-1100MAH

E-0 February 2015
F-0 March 2016
G-0 January 2017

KM-1100MWH

E-0 October 2015
F-0 March 2016
G-0 March 2017

KM-1100MRH

E-0 October 2015
F-0 March 2016
G-0 January 2017

Auxiliary Code Breakdown

The auxiliary code is the first two characters in the serial number. The first character indicates the year. Years progress or regress in alphabetical order. The series runs from "A" through "V" and the letters "I" and "O" are skipped. The second character indicates significant part changes within a year. Base is "0" and this number advances for each change. In cases where there is a letter in parentheses, this designates the month. This is the last character in the serial number. The series runs from "(A)" through "(M)" and the letter "(I)" is skipped. This designation is only included when identifying a parts change within an auxiliary code.

Note About Ordering Parts

Most assemblies cannot be ordered as complete units; parts in the assemblies generally must be ordered separately.

A. Main Assembly & Refrigeration Circuit
KM-1100MAH
 E-0 to G-0

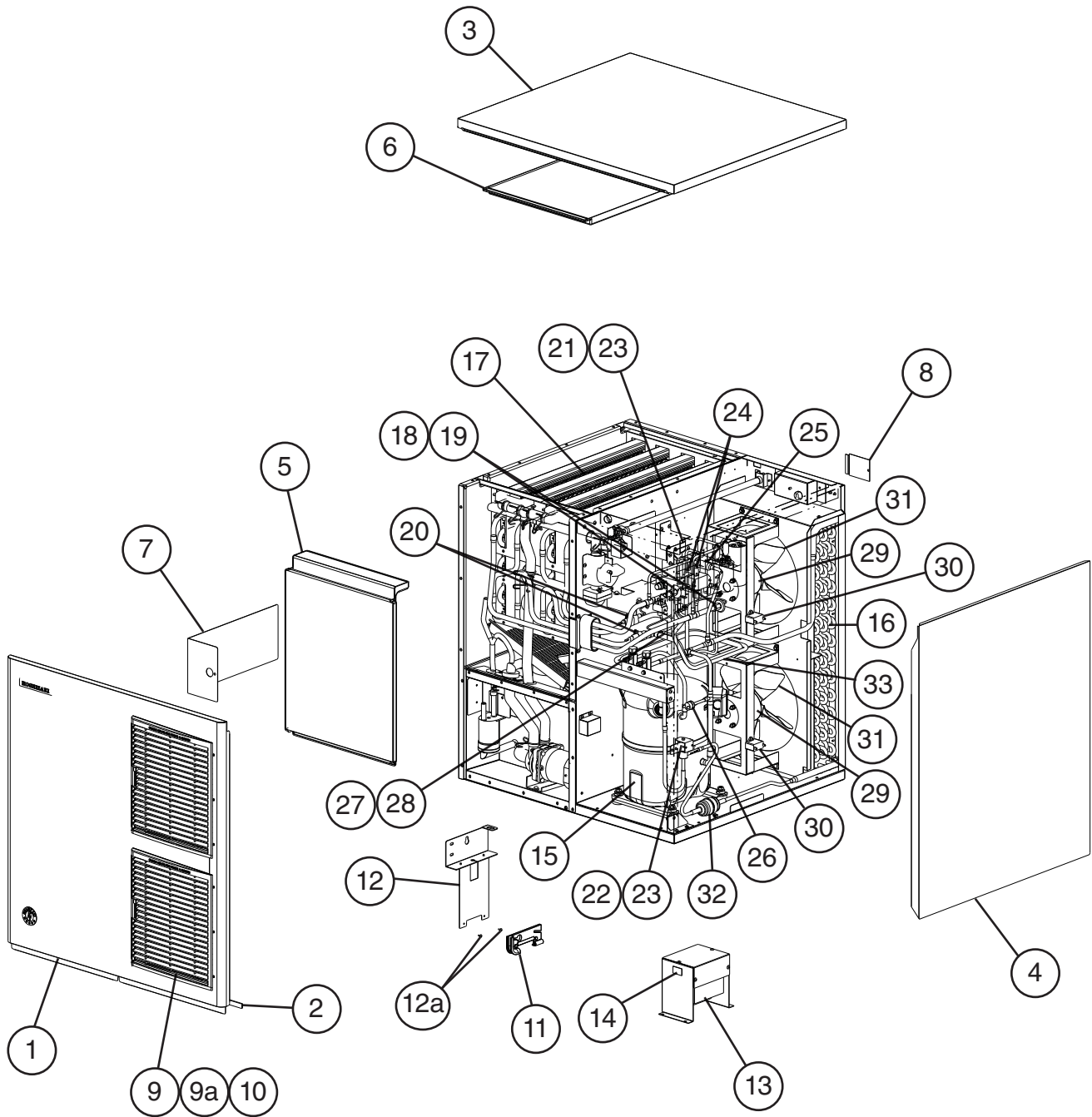

Title: A. Main Assembly & Refrigeration Circuit Model: KM-1100MAH												
Index No.	Description	Material or Model Number	Part Number	E-0 to G-0	Required Number							
Main Assembly												
1	Front Panel		1A3621-01	1								
2	Gasket	L=762 mm	4A0808L02	1								
3	Top Panel		3A1941A01	1								
4	Right Side Panel		1A3617G01	1								
5	Front Insulation		3A8392G01	1								
6	Top Insulation		322714G01	1								
7	Control Box Cover		3A2371-01	1								
8	Junction Box Cover		433410-01	1								
9	Louver		1A0547-01	2								
9a	Push Retainer		4A2414-01	6								
10	Air Filter		2A2062G01	2								
11	Bulb Holder		3A3903-01	1								
12	Bulb Holder Bracket		322815G02	1								
12a	Thumbscrew		415949G10	2								
13	Main Transformer		4A5695-01	1								
14	Voltage Tap Switch		4A1477-01	1								
Refrigeration Circuit												
15	Compressor		4A4134-03	1								
16	Condenser		1A3559-01	1								
17	Evaporator		1A3820G01	1								
18	Thermostatic Expansion Valve		4A4008-01	2								
19	Thermostatic Expansion Valve Cover		3A0944-01	2								
20	Thermostatic Expansion Valve Bulb Holder		3A0107-01	2								
21	Hot Gas Valve Body		4A3978-01	1								
22	Liquid Line Valve Body		4A3276-01	1								
23	Valve Coil		4A3277-01	2								
24	Check Valve		4A1373-01	2								
25	Strainer		441569-02	1								
26	High-Pressure Switch		463180-04	1								
27	Thermistor		429006-03	1								
28	Thermistor Holder		427430-01	1								
29	Fan Motor		4A3158-01	2								
30	Fan Motor Capacitor	5MFD, 250VAC	443192-02	2								
31	Fan Blade		4A3959-01	2								
32	Drier		4A2666-01	1								
33	Heat Exchanger		1A3601G01	1								

A. Main Assembly & Refrigeration Circuit
KM-1100MWH
E-0 to G-0

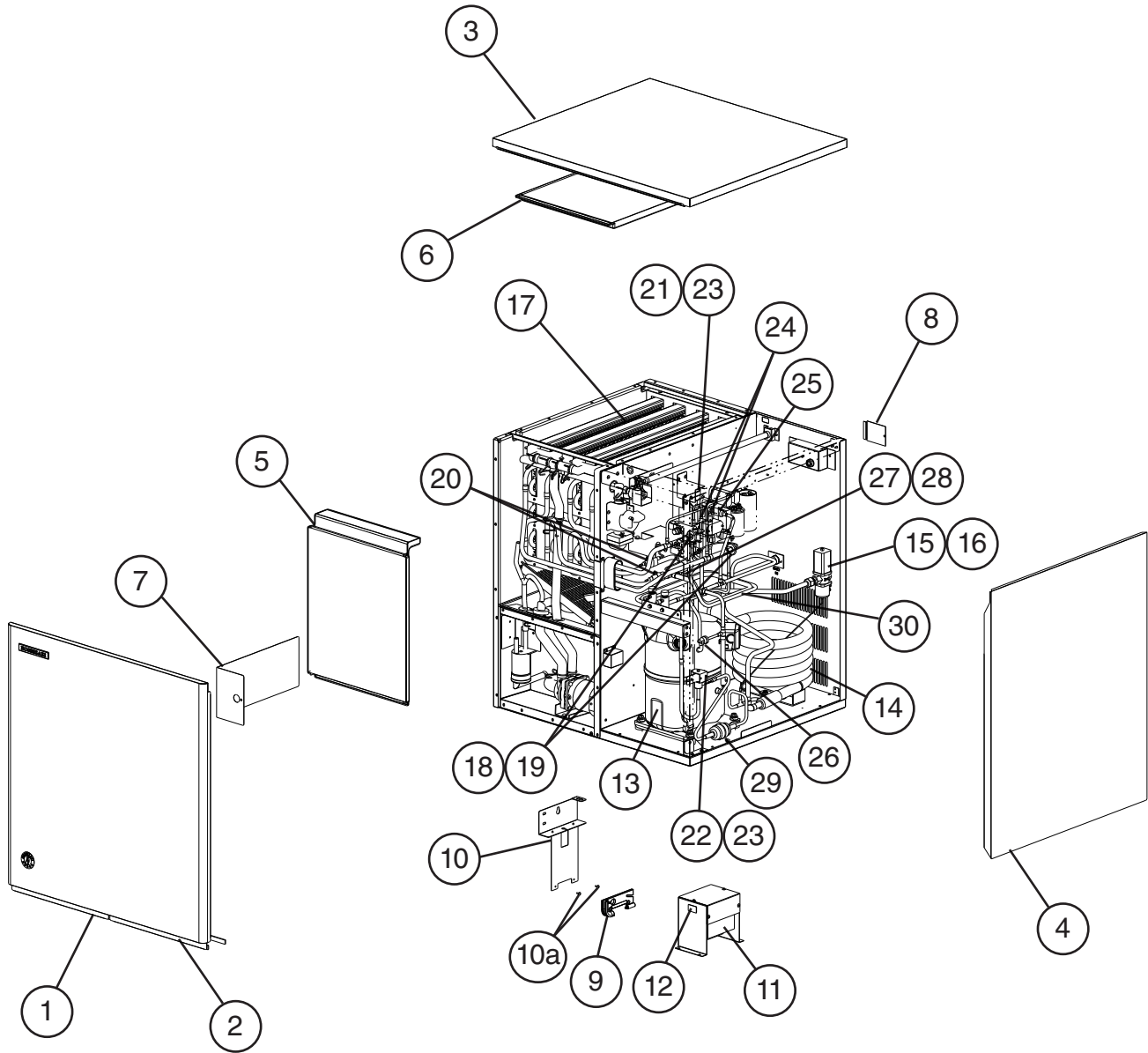

Title: A. Main Assembly & Refrigeration Circuit Model: KM-1100MWH												
Index No.	Description	Material or Model Number	Part Number	E-0 to G-0	Required Number							
Main Assembly												
1	Front Panel		1A3621-02	1								
2	Gasket	L=762 mm	4A0808L02	1								
3	Top Panel		3A1941A01	1								
4	Right Side Panel		1A3617G01	1								
5	Front Insulation		3A8392G01	1								
6	Top Insulation		322714G01	1								
7	Control Box Cover		3A2371-01	1								
8	Junction Box Cover		433410-01	1								
9	Bulb Holder		3A3903-01	1								
10	Bulb Holder Bracket		322815G02	1								
10a	Thumbscrew		415949G10	2								
11	Main Transformer		4A5695-01	1								
12	Voltage Tap Switch		4A1477-01	1								
Refrigeration Circuit												
13	Compressor		4A1539-03	1								
14	Condenser		3A7323-01	1								
15	Water Regulating Valve		4A0911-07	1								
16	Male Connector		4A1087-01	1								
17	Evaporator		1A3820G01	1								
18	Thermostatic Expansion Valve		4A4008-01	2								
19	Thermostatic Expansion Valve Cover		3A0944-01	2								
20	Thermostatic Expansion Valve Bulb Holder		3A0107-01	2								
21	Hot Gas Valve Body		4A3978-01	1								
22	Liquid Line Valve Body		4A3276-01	1								
23	Valve Coil		4A3277-01	2								
24	Check Valve		4A1373-01	2								
25	Strainer		441569-02	1								
26	High-Pressure Switch		463180-05	1								
27	Thermistor		429006-03	1								
28	Thermistor Holder		427430-01	1								
29	Drier		4A2666-01	1								
30	Heat Exchanger		1A3601G01	1								

A. Main Assembly & Refrigeration Circuit
KM-1100MRH
E-0 to G-0

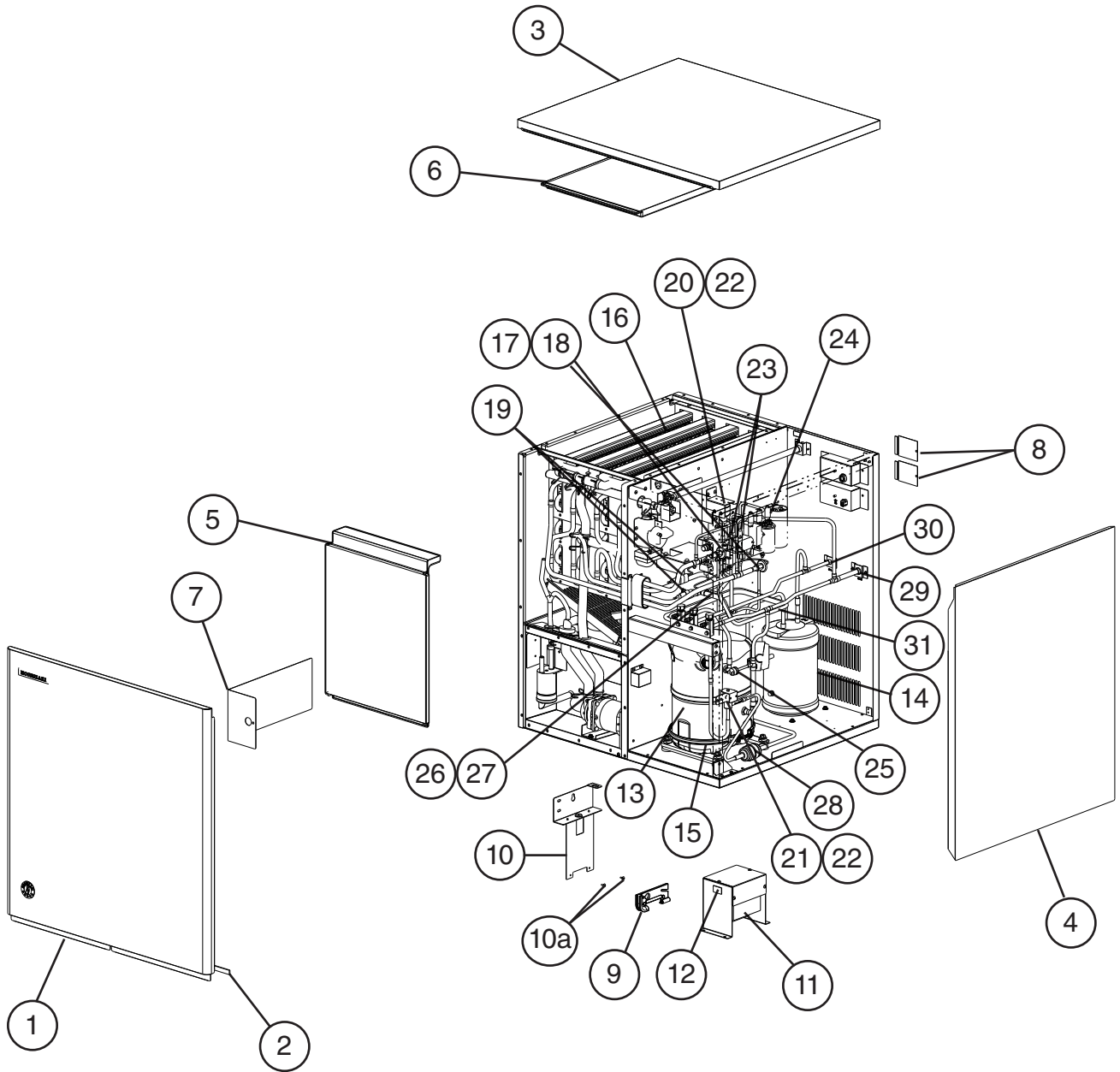

Title: A. Main Assembly & Refrigeration Circuit Model: KM-1100MRH												
Index No.	Description	Material or Model Number	Part Number	E-0 to G-0	Required Number							
Main Assembly												
1	Front Panel		1A3621-02	1								
2	Gasket	L=762 mm	4A0808L02	1								
3	Top Panel		3A1941A01	1								
4	Right Side Panel		1A3617G01	1								
5	Front Insulation		3A8392G01	1								
6	Top Insulation		322714G01	1								
7	Control Box Cover		3A2371-01	1								
8	Junction Box Cover		433410-01	2								
9	Bulb Holder		3A3903-01	1								
10	Bulb Holder Bracket		322815G02	1								
10a	Thumbscrew		415949G10	2								
11	Main Transformer		4A5695-01	1								
12	Voltage Tap Switch		4A1477-01	1								
Refrigeration Circuit												
13	Compressor		4A1539-03	1								
14	Receiver		437652-01	1								
15	Crankcase Heater		4A5397-02	1								
16	Evaporator		1A3820G01	1								
17	Thermostatic Expansion Valve		4A4008-01	2								
18	Thermostatic Expansion Valve Cover		3A0944-01	2								
19	Thermostatic Expansion Valve Bulb Holder		3A0107-01	2								
20	Hot Gas Valve Body		4A3978-01	1								
21	Liquid Line Valve Body		4A3276-01	1								
22	Valve Coil		4A3277-01	2								
23	Check Valve		4A1373-01	2								
24	Strainer		441569-02	1								
25	High-Pressure Switch		463180-04	1								
26	Thermistor		429006-03	1								
27	Thermistor Holder		427430-01	1								
28	Drier		4A2666-01	1								
29	Discharge Line Coupling		434136G01	1								
30	Liquid Line Coupling		4A3887G01	1								
31	Heat Exchanger		1A3601G01	1								

B. Water Circuit
KM-1100M_H
 E-0 to G-0

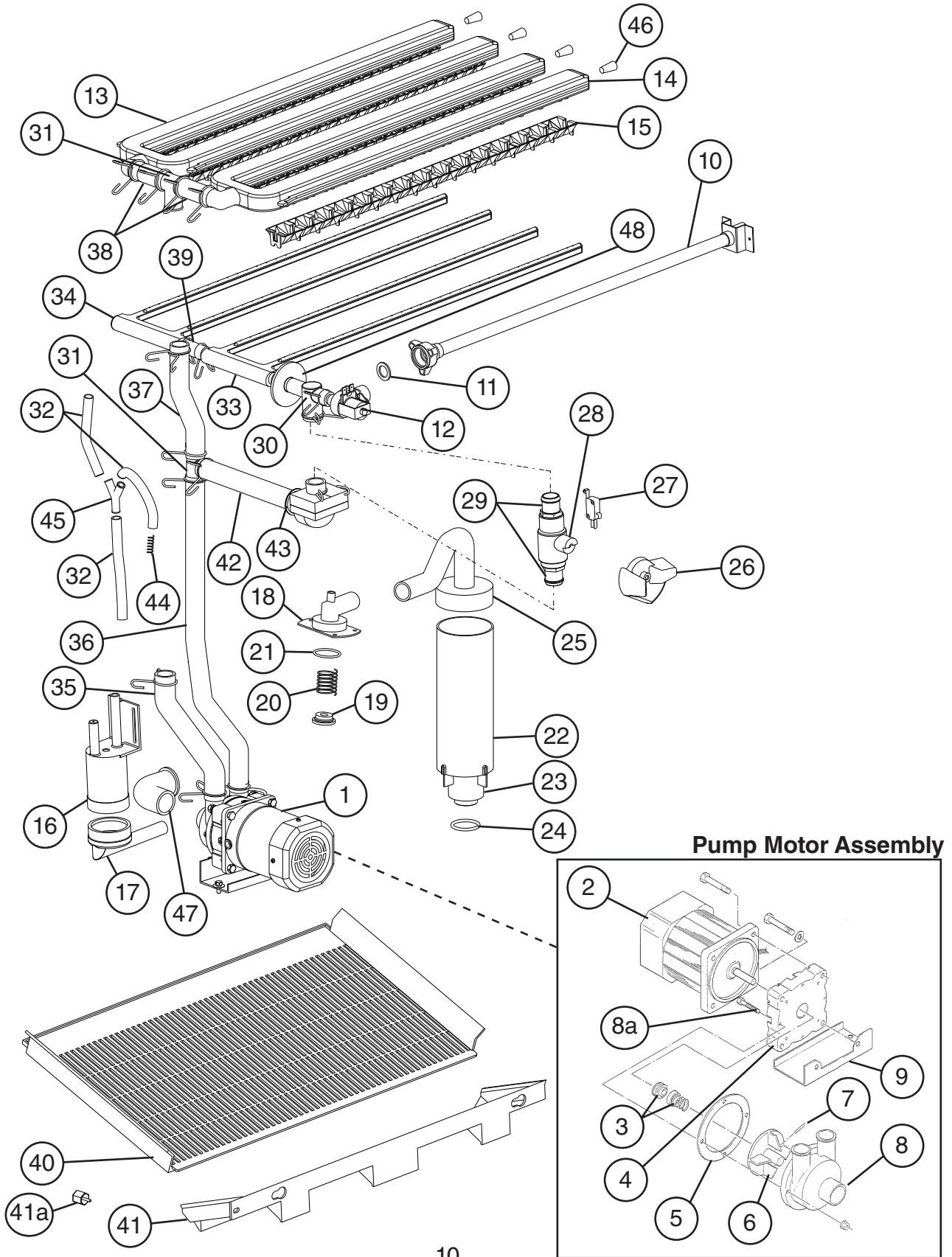

Title: B. Water Circuit Model: KM-1100M_H

Index No.	Description	Material or Model Number	Part Number	E-0 to G-0	Required Number									
1	Pump Motor Assembly (includes items 2 through 8a)	S-0731	215693A01	1										
2	Pump Motor		3A7682-01	1										
3	Mechanical Seal		4A3820-01	1										
4	Pump Flange		215662-01	1										
5	Packing		428547-01	1										
6	Impeller		428548-01	1										
7	Pin		4A0648-01	1										
8	Pump Housing		212636-01	1										
8a	Hexagon Bolt	4x30	7B02-0430	4										
9	Pump Motor Bracket		435057-01	1										
10	Water Supply Pipe		4A5216G04	1										
11	Rubber Gasket		413854-03	1										
12	Inlet Water Valve		4A5251-08	1										
13	Left Spray Tube		1A0260-02	1										
14	Right Spray Tube		1A0260-01	1										
15	Spray Guide		2A4282-02	4										
16	Float Switch		4A3624-02	1										
17	Float Switch Connector		426799-01	1										
18	Drain Valve Housing		3A1170-01	1										
19	Valve Seat		433705-01	1										
20	Spring		322685-01	1										
21	O-Ring		7611-G035	1										
22	Overflow Cap		322816-01	1										
23	Overflow Pipe		322691-02	1										
24	O-Ring		4A1234-01	1										
25	Hose (C)		326655-01	1										
26	Cleaning Valve Handle		215383-01	1										
27	Cleaning Valve Microswitch		4A2546-01	1										
28	Cleaning Valve Ball Valve		439293-01	1										
29	Cleaning Valve Male Adaptor		325826-01	2										
30	Distributor A (Tee)		4A0177-01	1										
31	Distributor B (Tee)		432426-01	2										
32	Silicone Hose	L=135 mm	773013812	3										
33	Right Water Supply Tube		2A0079-02	1										
34	Left Water Supply Tube		2A0079-01	1										
35	Drain Hose		435092-01	1										
36	Vinyl Hose	L=470 mm	7716-2025	1										
37	Vinyl Hose	L=170 mm	7716-2025	1										
38	Vinyl Hose	L=63 mm	7716-2025	2										
39	Vinyl Hose	L=47 mm	7716-1519	1										

Title: B. Water Circuit Model: KM-1100M_H												
Index No.	Description	Material or Model Number	Part Number	E-0 to G-0	Required Number							
40	Cube Guide A		214905-01	1								
41	Cube Guide B		322644-02	1								
41a	Thumbscrew		415949G12	1								
42	Bypass Hose		439265-01	1								
43	Rubber Ring		439236-01	1								
44	Spring		435825-01	1								
45	Connector		432763-01	1								
46	Plug		4A0176-01	4								
47	Inlet Hose A		435091-01	1								
48	Flange		439267-01	1								
Hose Clamps												
	Hose Clamp	25 mm	427443-03	11								
		18 mm	427443-05	3								
		27 mm	427443-08	2								

C. Control Box Assembly

KM-1100M_H

E-0 to G-0

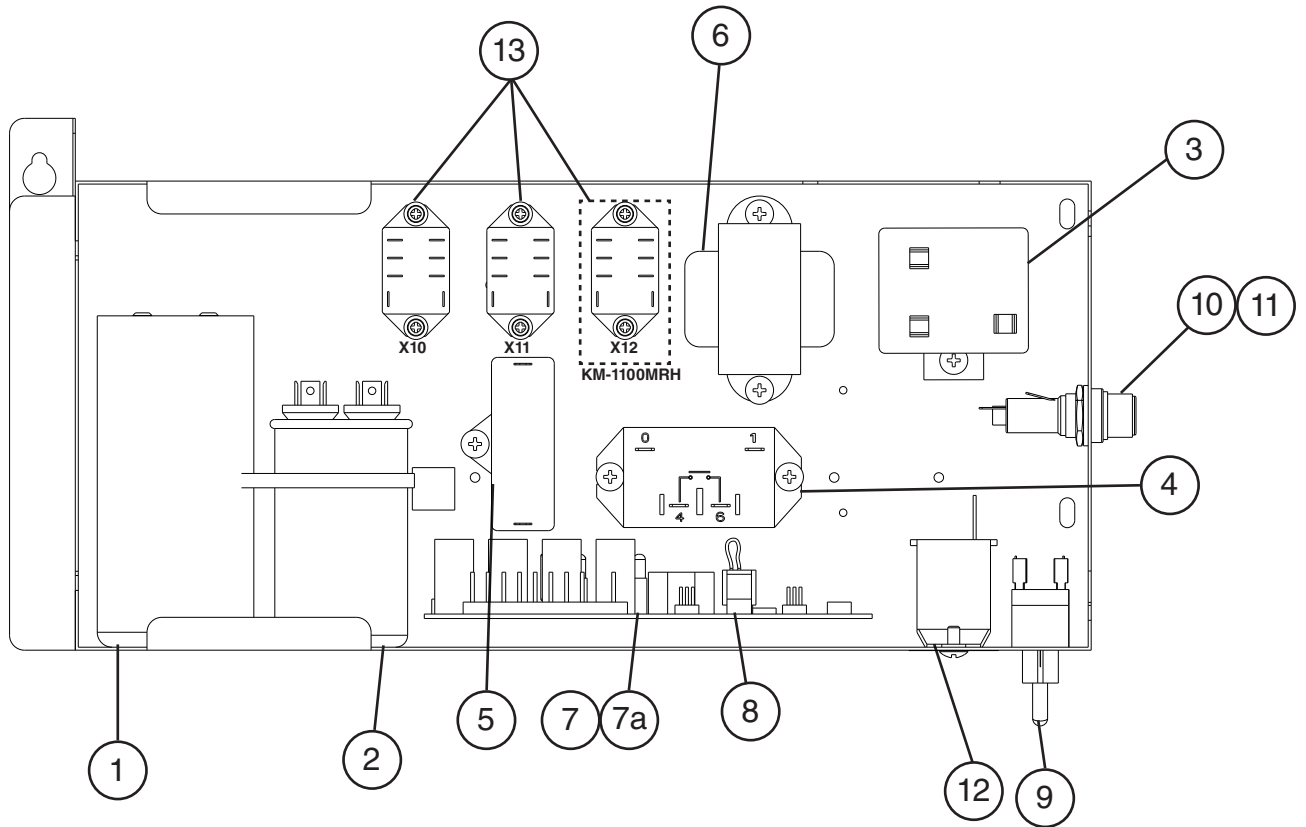

Title: C. Control Box Assembly Model: KM-1100M_H				Required Number											
Index No.	Description	Material or Model Number	Part Number	E-0 to G-0											
1	Start Capacitor	145-174MFD, 220VAC	3A0076-11	1											
2	Run Capacitor	30MFD, 370VAC	3A2005-03	1											
3	Start Relay		4A1107-13	1											
4	Compressor Relay		4A3140-01	1											
5	Pump Motor Capacitor	10MFD, 250VAC	443192-01	1											
6	Control Transformer		3A0172-01	1											
7	Control Board		2A3792-01	1											
7a	Control Board Support		4A0336-03	4											
8	K4 Jumper		4A4883G01	1											
9	Control Switch		443119-01	1											
10	Fuse Holder		4A5443-01	1											
11	Fuse	GMD-10A, 250VAC	4A0893-07	1											
12	Bin Control Thermostat		4A2879-02	1											
13	Relay (X10 and X11)		406132-07	2											
	Relay (X12)	KM-1100MRH		1											

D. Accessories & Labels

KM-1100M_H

E-0 to G-0

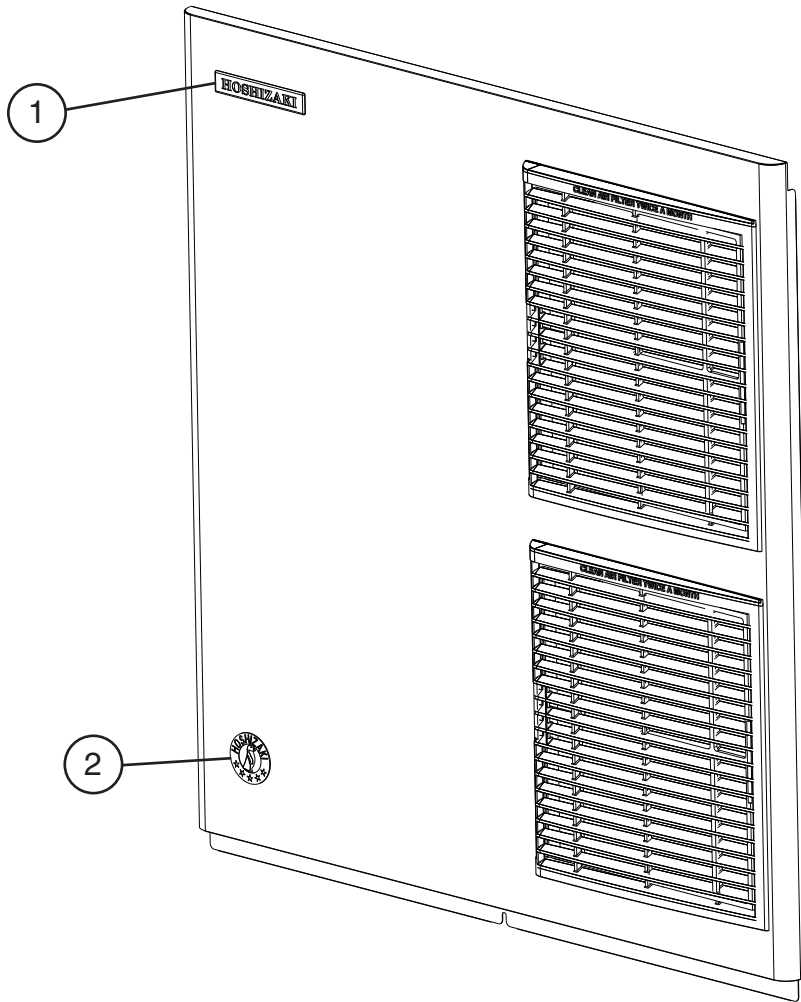

Title: D. Accessories & Labels Model: KM-1100M_H										
Index No.	Description	Material or Model Number	Part Number	Required Number						
				E-0 to G-0						
1	Hoshizaki Emblem Label		4A0560-01	1						
2	Penguin Label		475552L02	1						
3	Universal Brace		4A0363-01	2						
3a	Hex Head Bolt		7B02-0512	2						