



# HOSHIZAKI

## Parts List

Crescent Cuber

Model  
KM-151BAH



[hoshizakiamerica.com](http://hoshizakiamerica.com)

Number: M008-3040  
Issued: 4-2016

## Auxiliary Codes

<b>KM-151BAH</b>	S-1	July 2007
	S-2	September 2007
	S-3	December 2007
	T-0	January 2008
	T-1	May 2008
	U-0	January 2009
	U-1	February 2009
	V-0	January 2010
	V-1	June 2010
	A-0	January 2011
	B-0	January 2012
	C-0	January 2013
	D-0	January 2014
	E-0	January 2015
	E-1	September 2015

## Auxiliary Code Breakdown

The auxiliary code is the first two characters in the serial number. The first character indicates the year. Years progress or regress in alphabetical order. The series runs from "A" through "V" and the letters "I" and "O" are skipped. The second character indicates significant part changes within a year. Base is "0" and this number advances for each change. In cases where there is a letter in parentheses, this designates the month. This is the last character in the serial number. The series runs from "(A)" through "(M)" and the letter "(I)" is skipped. This designation is only included when identifying a parts change within an auxiliary code.

## Note About Ordering Parts

Most assemblies cannot be ordered as complete units; parts in the assemblies generally must be ordered separately.

## MARKS LOCATED UNDER THE AUXILIARY CODE

- = Part deleted.
- x = Part deleted and replaced by "o" part.
- o = New part in place of "x" part.

## FASTENER PART NUMBER

### SCREWS

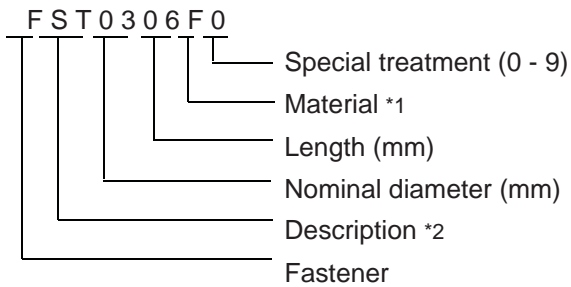

\*1

- F: Steel
- S: Austenitic stainless steel
- M: Martensitic stainless steel
- B: Copper alloy
- P: Polycarbonate
- N: Polyamide
- V: PVC
- A: ABS
- X: Polyacetal
- L: Aluminum

### NUTS & WASHERS

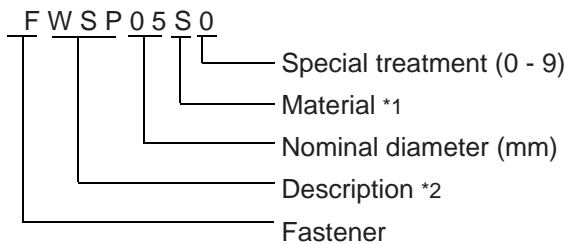

\*2

- First letter
- S: Machine screw
- T: Tapping screw
- M: Wood screw
- B: Bolt
- W: Washer
- N: Nut

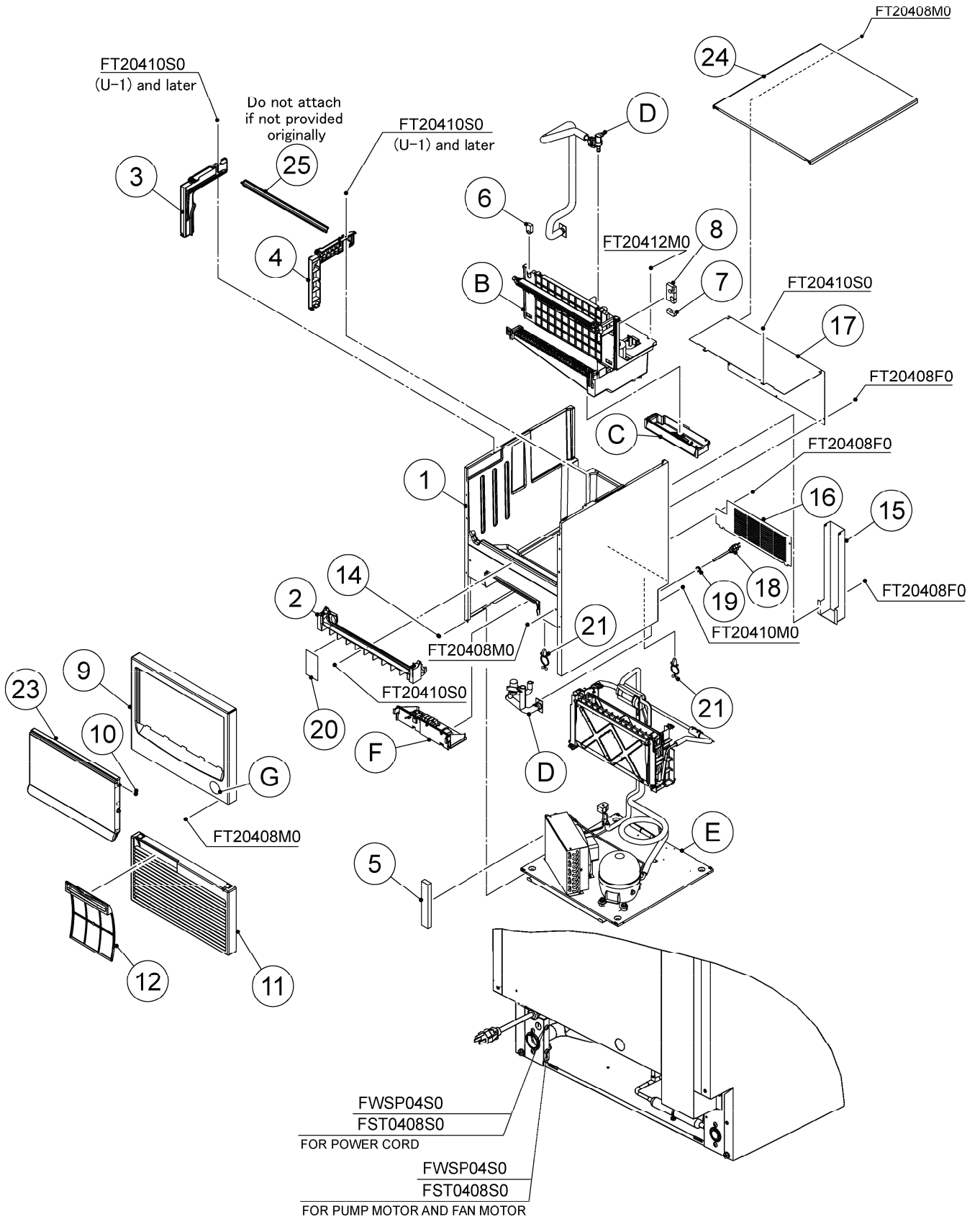

HA

MODEL: <b>KM-151BAH</b>		TITLE: <b>A. ICE CUBER ASSY</b>						
INDEX NO.	DESCRIPTION	MATERIAL OR MODEL NUMBER	PART NUMBER	REQ'D NUMBER				
				S-1,S-2	S-3,T-0	T-1,U-0	U-1,V-0	V-1,E-0
B	ICE MAKING MECHANISM ASSY		118493A01	1	1	1	1	1
C	MECHANICAL BIN SWITCH		369013A01	1	1	-	-	-
			371151A01	-	-	1	1	1
D	WATER CIRCUIT ASSY		253740A01	1	-	-	-	-
			253740A02	-	1	1	1	1
E	REFRIGERATION CIRCUIT		118496A01	1	1	1	1	1
F	CONTROL BOX ASSY		252005A06	1	1	1	1	1
G	LABEL LOCATION		254314S01	1	1	1	1	1
K	ACCESSORIES			1	1	1	1	1
M	OPTIONAL PARTS	before serial number D02570L		1	1	1	1	1
		serial number D02570L and later						-
1	BODY ASSY		118012G01	1	1	1	-	-
			119364G01	-	-	-	1	1
2	FRONT FRAME		250745-01	1	1	1	1	1
3	RAIL (L)		117628-01	1	1	1	-	-
			119369P01	-	-	-	1	1
4	RAIL (R)		117629-01	1	1	1	-	-
			119370P01	-	-	-	1	1
5	AIR GUARD		470302-02	1	1	1	1	1
6	GROMMET-PIPE (C)	SANTOPRENE	470311-01	1	1	1	1	1
7	GROMMET-PIPE (B)	SANTOPRENE	470310-01	1	1	1	1	1
8	GROMMET-PIPE (A)	SANTOPRENE	470309-01	1	1	1	1	1
9	FRONT PANEL	before serial number D02570L	369014G01	1	1	1	1	1
		serial number D02570L and later	380575G01					1
10	COLLAR		481481P02	4	4	4	4	4
11	LOUVER		117635-01	1	1	1	1	1
12	AIR FILTER		250727G01	1	1	1	1	1
14	HEX. TAPPING SCREW W - FLANGE		P01572-01	4	4	4	4	4
15	COVER - PIPE		368305-02	1	1	1	1	1
16	REAR COVER		368313-01	1	1	1	1	1

HA

MODEL: <b>KM-151BAH</b>		TITLE: <b>A. ICE CUBER ASSY</b>						
INDEX NO.	DESCRIPTION	MATERIAL OR MODEL NUMBER	PART NUMBER	REQ'D NUMBER				
				S-1,S-2	S-3,T-0	T-1,U-0	U-1,V-0	V-1,E-0
17	REAR PANEL		370654M03	1	1	1	1	1
18	POWER SUPPLY CORD	KP-30B SJT#16AWG	P00004-01	1	1	1	1	1
19	BUSHING	SR-7K-2	420472-02	1	1	1	1	1
20	SEAL - OVERFLOW		4Y4321P01	1	1	1	1	1
21	CLAMP		427902-02	5	5	5	5	5
23	DOOR	Replace together with 4 pieces of No.10 COLLAR	369051G01	1	1	1	1	1
24	TOP PANEL	before serial number D02570L	369005A09	1	1	1	1	1
		serial number D02570L and later	380577A09					1

HA

MODEL: <b>KM-151BAH</b>		TITLE: <b>A. ICE CUBER ASSY</b>						
INDEX NO.	DESCRIPTION	MATERIAL OR MODEL NUMBER	PART NUMBER	REQ'D NUMBER				
				E-1				
B	ICE MAKING MECHANISM ASSY		118493A01	1				
C	MECHANICAL BIN SWITCH		369013A01	-				
			371151A01	1				
D	WATER CIRCUIT ASSY		253740A01	-				
			253740A02	1				
E	REFRIGERATION CIRCUIT		118496A01	1				
F	CONTROL BOX ASSY		252005A06	1				
G	LABEL LOCATION		254314S01	1				
K	ACCESSORIES			1				
M	OPTIONAL PARTS	before serial number D02570L		-				
		serial number D02570L and later		-				
1	BODY ASSY		118012G01	-				
			119364G01	1				
2	FRONT FRAME		250745-01	1				
3	RAIL (L)		117628-01	-				
			119369P01	1				
4	RAIL (R)		117629-01	-				
			119370P01	1				
5	AIR GUARD		470302-02	1				
6	GROMMET-PIPE (C)	SANTOPRENE	470311-01	1				
7	GROMMET-PIPE (B)	SANTOPRENE	470310-01	1				
8	GROMMET-PIPE (A)	SANTOPRENE	470309-01	1				
9	FRONT PANEL	before serial number D02570L	369014G01	-				
		serial number D02570L and later	380575G01	1				
10	COLLAR		481481P02	4				
11	LOUVER		117635-01	1				
12	AIR FILTER		250727G01	1				
14	HEX. TAPPING SCREW W - FLANGE		P01572-01	4				
15	COVER - PIPE		368305-02	1				
16	REAR COVER		368313-01	1				

HA

MODEL: <b>KM-151BAH</b>		TITLE: <b>A. ICE CUBER ASSY</b>						
INDEX NO.	DESCRIPTION	MATERIAL OR MODEL NUMBER	PART NUMBER	REQ'D NUMBER				
				E-1				
17	REAR PANEL		370654M03	1				
18	POWER SUPPLY CORD	KP-30B SJT#16AWG	P00004-01	1				
19	BUSHING	SR-7K-2	420472-02	1				
20	SEAL - OVERFLOW		4Y4321P01	1				
21	CLAMP		427902-02	5				
23	DOOR		369051G01	1				
24	TOP PANEL	before serial number D02570L	369005A09	-				
		serial number D02570L and later	380577A09	1				
25	BRACE - RAIL	Do not attach if not provided originally	481548M02	1				



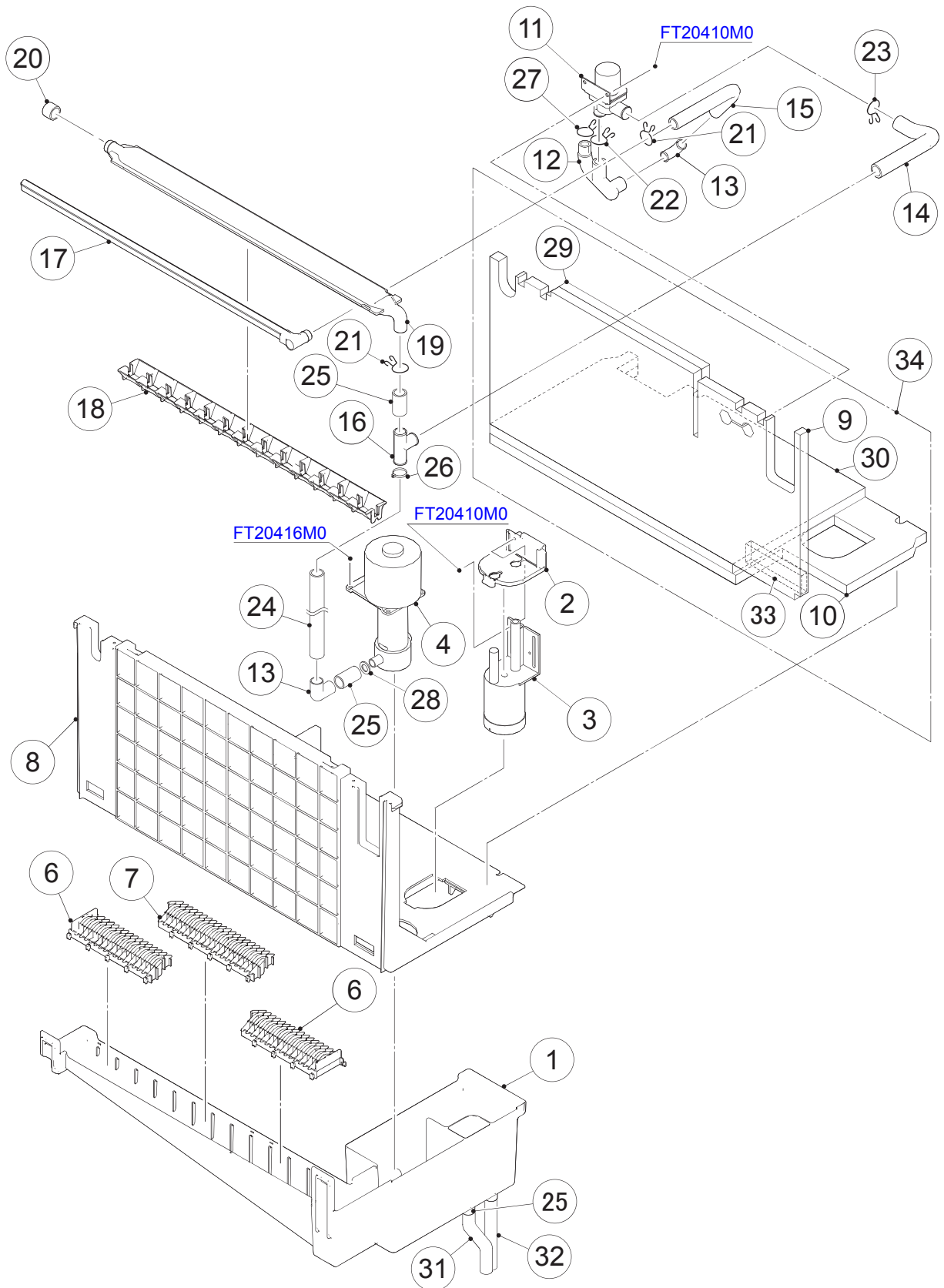

HA

MODEL: <b>KM-151BAH</b>		TITLE: <b>B. ICE MAKING MECHANISM ASSY</b>						
INDEX NO.	DESCRIPTION	MATERIAL OR MODEL NUMBER	PART NUMBER	REQ'D NUMBER				
				S-1,S-2	S-3,T-0	T-1,U-0	U-1,V-0	V-1,E-0
1	WATER TANK		117639-01	1	1	1	1	1
2	BRACKET - FLOAT SWITCH		368339-01	1	1	1	1	1
3	FLOAT SWITCH		4A3624-04	1	1	1	1	1
4	PUMP MOTOR	PV-0511BHZ1	P00468-01	1	1	1	1	1
5	ELBOW		417703-01	1	1	1	1	1
6	CUBE GUIDE (A)		250742-01	2	2	2	2	2
7	CUBE GUIDE (C)		250740-01	1	1	1	1	1
8	BRACKET - ICE MAKING		117632-01	1	1	1	1	1
9	INSULATION - MECHANISM (A)	Only available as No.34.	368347-01	-	-	-	-	-
10	INSULATION - MECHANISM (B)	Only available as No.34.	368346-01	-	-	-	-	-
11	SOLENOID VALVE	DSVP12N-2NSX-120A-L3SR	4A3722-01	1	1	1	-	
		FDC-90-02-115	P00018-02	-			1	1
12	WATER SUPPLY PIPE (A)		470306-01	1	1	1	1	1
13	ELBOW		470303-01	1	1	1	1	1
14	BYPASS HOSE		470408-01	1	1	1	1	-
			374229R01	-	-	-	-	1
15	WATER SUPPLY PIPE(B)		470307-01	1	1	1	1	-
	WATER SUPPLY HOSE (B)		374228R01	-	-	-	-	1
16	TEE		470312-01	1	1	1	1	1
17	WATER SUPPLY TUBE		269616G01	1	1	1	1	1
18	SPRAY GUIDE		252052P03	1	1	1	1	-
			258313P05	-	-	-	-	1
19	SPRAY TUBE		250746-03	1	1	1	1	1
20	SPRAY TUBE CAP ※Use either of the right		3A2645-01	1	1	1	1	1
			370777R01	1	1	1	1	1
21	HOSE CLAMP ※Use either of the right	16.5mm SUS	427443-04	2	2	2	2	2
			P02909-04	2	2	2	2	2
22	HOSE CLAMP ※Use either of the right	18mm SUS	427443-05	1	1	1	1	1
			P02909-05	1	1	1	1	1

HA

MODEL: <b>KM-151BAH</b>		TITLE: <b>B. ICE MAKING MECHANISM ASSY</b>						
INDEX NO.	DESCRIPTION	MATERIAL OR MODEL NUMBER	PART NUMBER	REQ'D NUMBER				
				S-1,S-2	S-3,T-0	T-1,U-0	U-1,V-0	V-1,E-0
23	HOSE CLAMP ※Use either of the right	20mm SUS	427443-06	1	1	1	1	1
			P02909-06	1	1	1	1	1
24	SILICONE HOSE	L=300 14 DIA x 18 DIA	H11418300	1	1	1	1	-
		L=280 14 DIA x 18 DIA (CLEAR)	H11418280	-	-	-	-	1
25	SILICONE HOSE	L=30 14 DIA x 18 DIA (CLEAR)	H11418030	3	3	3	3	3
26	CABLE TIE	CV-100	7920-0002	8	8	8	8	8
27	HOSE CLAMP ※Use either of the right	13.5mm SUS	427443-07	1	1	1	1	1
			P02909-07	1	1	1	1	1
28	ORIFICE		4Y4194P02	1	1	1	1	1
29	INSULATION/MECHANISM (C)	Only available as No.34.	3Y2430Z01	-	-	-	-	-
30	INSULATION/MECHANISM (D)	Only available as No.34.	3Y2431Z01	-	-	-	-	-
31	PIPE/OVERFLOW		369038P03	1	1	1	1	1
32	SILICONE HOSE	L=230 14 DIA x 18 DIA (CLEAR)	H11418230	1	1	1	1	1
33	INSULATION - PUMP	Only available as No.34.	472395Z01	-	-	-	-	-
34	INSULATION - MECHANISM		256827P01	-	-	-	1	1

HA

MODEL: <b>KM-151BAH</b>		TITLE: <b>B. ICE MAKING MECHANISM ASSY</b>						
INDEX NO.	DESCRIPTION	MATERIAL OR MODEL NUMBER	PART NUMBER	REQ'D NUMBER				
				E-1				
1	WATER TANK		117639-01	1				
2	BRACKET - FLOAT SWITCH		368339-01	1				
3	FLOAT SWITCH		4A3624-04	1				
4	PUMP MOTOR	PV-0511BHZ1	P00468-01	1				
5	ELBOW		417703-01	1				
6	CUBE GUIDE (A)		250742-01	2				
7	CUBE GUIDE (C)		250740-01	1				
8	BRACKET - ICE MAKING		117632-01	1				
9	INSULATION - MECHANISM (A)	Only available as No.34.	368347-01	-				
10	INSULATION - MECHANISM (B)	Only available as No.34.	368346-01	-				
11	SOLENOID VALVE	DSVP12N-2NSX-120A-L3SR	4A3722-01					
		FDC-90-02-115	P00018-02	1				
12	WATER SUPPLY PIPE (A)		470306-01	1				
13	ELBOW		470303-01	1				
14	BYPASS HOSE		470408-01	-				
			374229R01	1				
15	WATER SUPPLY PIPE(B)		470307-01	-				
	WATER SUPPLY HOSE (B)		374228R01	1				
16	TEE		470312-01	1				
17	WATER SUPPLY TUBE		269616G01	1				
18	SPRAY GUIDE		252052P03	-				
			258313P05	1				
19	SPRAY TUBE		250746-03	1				
20	SPRAY TUBE CAP ※Use either of the right		3A2645-01	1				
			370777R01	1				
21	HOSE CLAMP ※Use either of the right	16.5mm SUS	427443-04	2				
			P02909-04	2				
22	HOSE CLAMP ※Use either of the right	18mm SUS	427443-05	1				
			P02909-05	1				

HA

MODEL: <b>KM-151BAH</b>		TITLE: <b>B. ICE MAKING MECHANISM ASSY</b>						
INDEX NO.	DESCRIPTION	MATERIAL OR MODEL NUMBER	PART NUMBER	REQ'D NUMBER				
				E-1				
23	HOSE CLAMP ※Use either of the right	20mm SUS	427443-06	1				
			P02909-06	1				
24	SILICONE HOSE	L=300 14 DIA x 18 DIA	H11418300	-				
		L=280 14 DIA x 18 DIA (CLEAR)	H11418280	1				
25	SILICONE HOSE	L=30 14 DIA x 18 DIA (CLEAR)	H11418030	3				
26	CABLE TIE	CV-100	7920-0002	8				
27	HOSE CLAMP ※Use either of the right	13.5mm SUS	427443-07	1				
			P02909-07	1				
28	ORIFICE		4Y4194P02	1				
29	INSULATION/MECHANISM (C)	Only available as No.34.	3Y2430Z01	-				
30	INSULATION/MECHANISM (D)	Only available as No.34.	3Y2431Z01	-				
31	PIPE/OVERFLOW		369038P03	1				
32	SILICONE HOSE	L=230 14 DIA x 18 DIA (CLEAR)	H11418230	1				
33	INSULATION - PUMP	Only available as No.34.	472395Z01	-				
34	INSULATION - MECHANISM		256827P01	1				

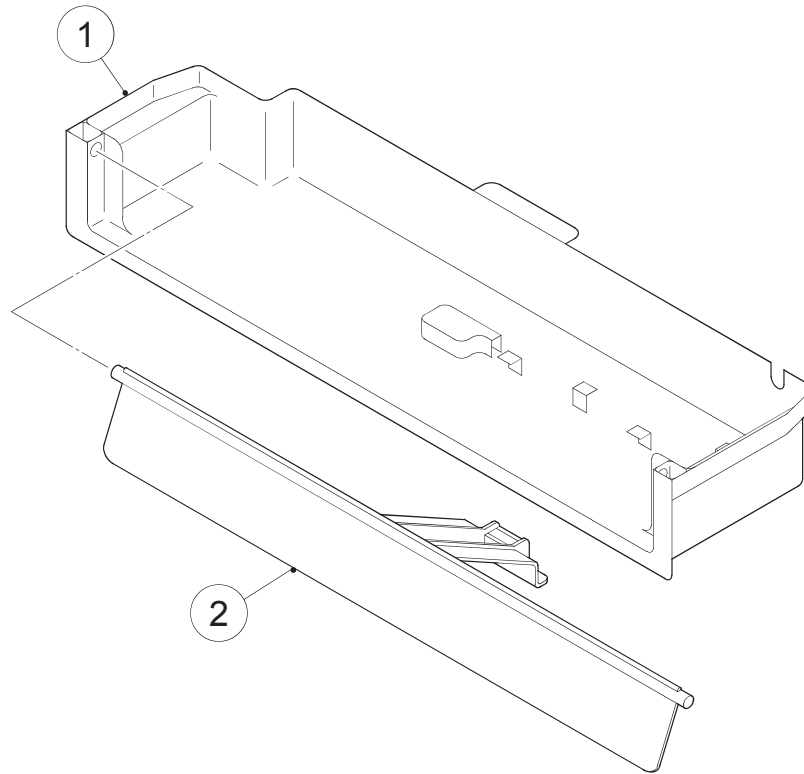

HA

MODEL: <b>KM-151BAH</b>		TITLE: <b>C. MECHANICAL BIN SWITCH</b>						
INDEX NO.	DESCRIPTION	MATERIAL OR MODEL NUMBER	PART NUMBER	REQ'D NUMBER				
				S-1,S-2	S-3,T-0	T-1,U-0	U-1,V-0	V-1,E-0
1	MECHANICAL SWITCH CASE		369019G01	1	1	-	-	-
			371153G01	-	-	1	1	1
2	DETECTOR		369020G01	1	1	-	-	-
			371152G01	-	-	1	1	1

HA

MODEL: <b>KM-151BAH</b>		TITLE: <b>C. MECHANICAL BIN SWITCH</b>						
INDEX NO.	DESCRIPTION	MATERIAL OR MODEL NUMBER	PART NUMBER	REQ'D NUMBER				
				E-1				
1	MECHANICAL SWITCH CASE		369019G01	-				
			371153G01	1				
2	DETECTOR		369020G01	-				
			371152G01	1				



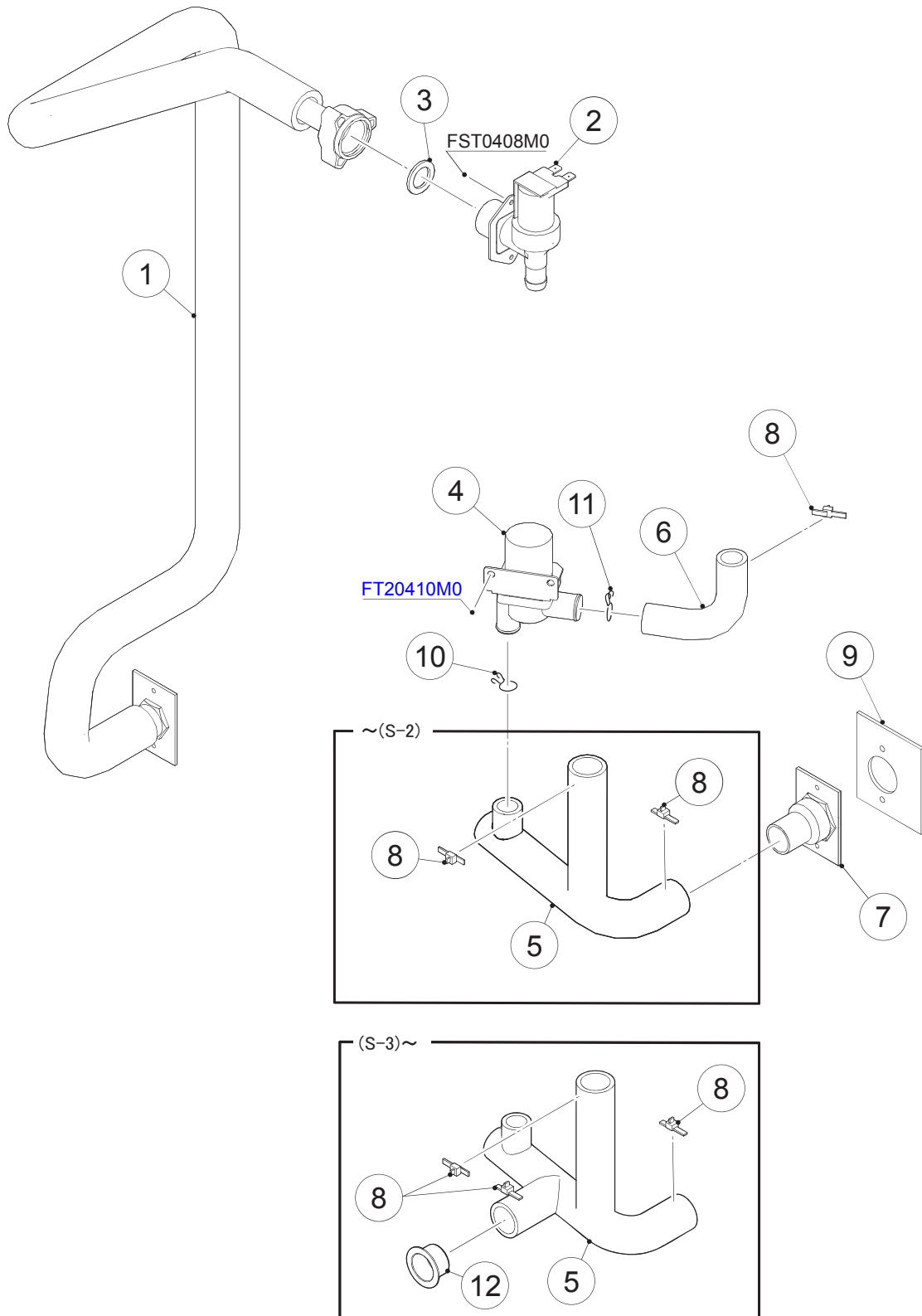

HA

MODEL: <b>KM-151BAH</b>		TITLE: <b>D. WATER CIRCUIT ASSY</b>						
INDEX NO.	DESCRIPTION	MATERIAL OR MODEL NUMBER	PART NUMBER	REQ'D NUMBER				
				S-1,S-2	S-3,T-0	T-1,U-0	U-1,V-0	V-1,E-0
1	WATER SUPPLY PIPE		369037G01	1	1	1	1	1
2	WATER VALVE	V19, 1.2L/min	P00464-01	1	1	1	1	1
3	RUBBER GASKET		413854-03	1	1	1	1	1
4	SOLENOID VALVE	DSVP12N-2NSX-120A-L3SR	4A3722-01	1	1	1	-	-
		FDC-90-02-115	P00018-02	-	-	-	1	1
5	DRAIN HOSE	EPDM OR SANTOPRENE	470305-01	1	x1	-	-	-
5	DRAIN HOSE	SANTOPRENE	370704R01	-	o1	1	1	1
6	HOSE - VALVE	SANTOPRENE	470304-01	1	1	1	1	1
7	DRAIN FITTING		472726G01	1	1	1	1	1
8	CABLE TIE	CV-150	7920-0003	3	4	4	4	4
9	INSULATION/DRAIN		4Y4319Z01	1	1	1	1	1
10	HOSE CLAMP ※Use either of the right	18mm SUS	427443-05	1	1	1	1	1
			P02909-05	1	1	1	1	1
11	HOSE CLAMP ※Use either of the right	20mm SUS	427443-06	1	1	1	1	1
			P02909-06	1	1	1	1	1
12	CAP		472250P01	-	1	1	1	1

HA

MODEL: <b>KM-151BAH</b>		TITLE: <b>D. WATER CIRCUIT ASSY</b>							
INDEX NO.	DESCRIPTION	MATERIAL OR MODEL NUMBER	PART NUMBER	REQ'D NUMBER					
				E-1					
1	WATER SUPPLY PIPE		369037G01	1					
2	WATER VALVE	V19, 1.2L/min	P00464-01	1					
3	RUBBER GASKET		413854-03	1					
4	SOLENOID VALVE	DSVP12N-2NSX-120A-L3SR	4A3722-01	-					
		FDC-90-02-115	P00018-02	1					
5	DRAIN HOSE	EPDM OR SANTOPRENE	470305-01	-					
5	DRAIN HOSE	SANTOPRENE	370704R01	1					
6	HOSE - VALVE	SANTOPRENE	470304-01	1					
7	DRAIN FITTING		472726G01	1					
8	CABLE TIE	CV-150	7920-0003	4					
9	INSULATION/DRAIN		4Y4319Z01	1					
10	HOSE CLAMP ※Use either of the right	18mm SUS	427443-05	1					
			P02909-05	1					
11	HOSE CLAMP ※Use either of the right	20mm SUS	427443-06	1					
			P02909-06	1					
12	CAP		472250P01	1					

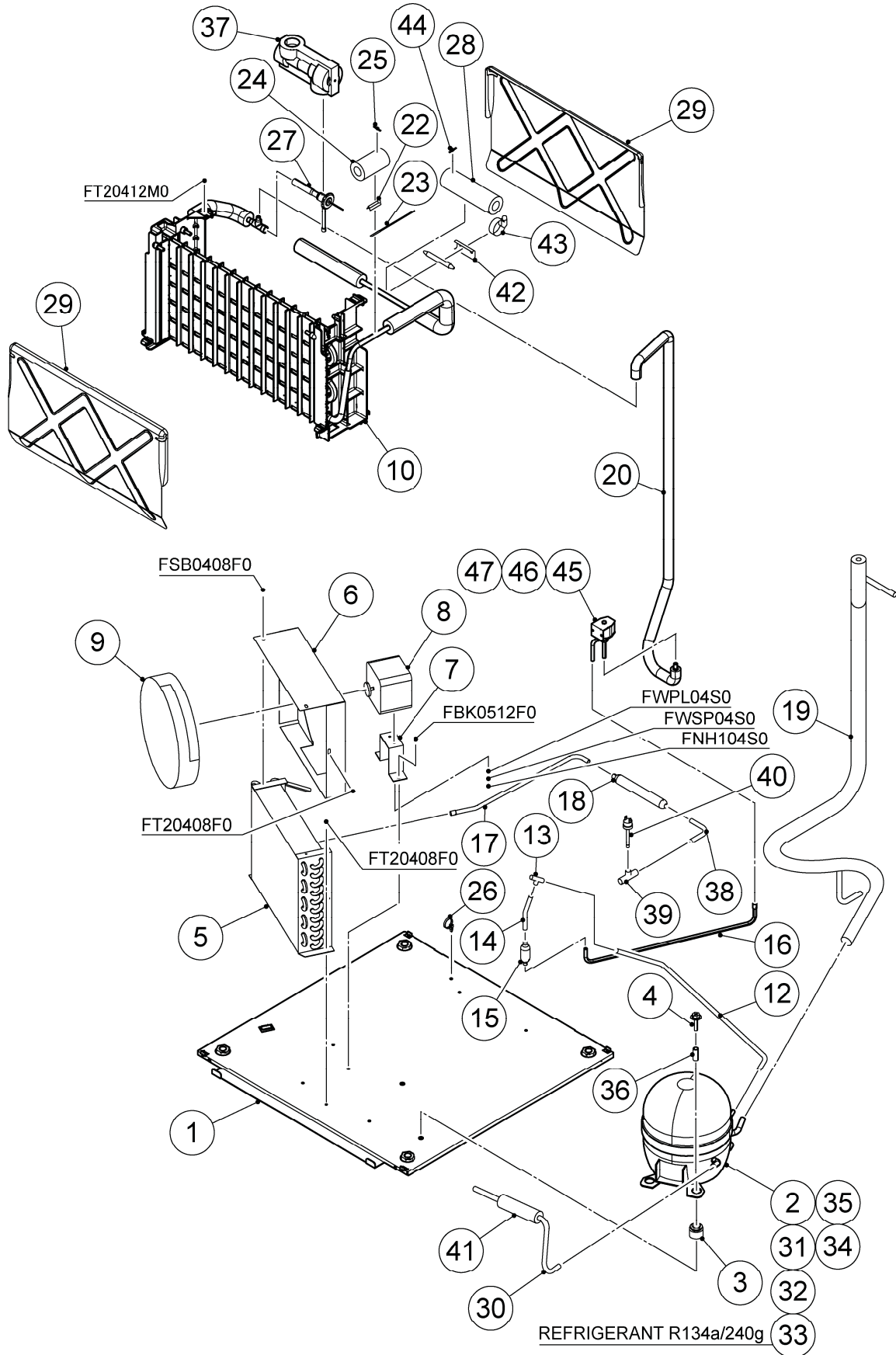

HA

MODEL: <b>KM-151BAH</b>		TITLE: <b>E. REFRIGERATION CIRCUIT</b>						
INDEX NO.	DESCRIPTION	MATERIAL OR MODEL NUMBER	PART NUMBER	REQ'D NUMBER				
				S-1,S-2	S-3,T-0	T-1,U-0	U-1,V-0	V-1,E-0
1	BASE		370284G01	1	1	1	1	1
2	COMPRESSOR	QA125K29CAU6-E0GS	P00025-01	1	1	1	1	1
3	RUBBER GROMMET	01-245970	463983-01	4	4	4	4	4
4	BOLT	8x35	436206-03	2	2	2	2	2
5	CONDENSER		P00030-01	1	1	1	1	1
6	SHROUD		3Y2364M01	1	1	1	1	1
7	BRACKET - FM		470291-01	1	1	1	1	1
8	FAN MOTOR	M4Q045-CA27-04	P00466-01	1	1	1	1	1
9	FAN BLADE	200 DIA (22°)	P00006-01	1	1	1	1	1
10	EVAPORATOR ASSY		252014G01	1	1	1	1	-
			258411G01	-	-	-	-	1
12	COPPER TUBE(A) - HI		368334-01	1	1	1	1	1
13	TEE		420041-03	1	1	1	1	1
14	COPPER TUBE(B) - HI		470297-01	1	1	1	1	1
15	STRAINER		P00008-01	1	1	1	1	1
16	COPPER TUBE(C) - HI		471943M01	1	1	1	1	1
17	COPPER TUBE(D) - HI		470295-01	1	1	1	1	1
18	DRIER		P00026-01	1	1	1	1	1
19	HEAT EXCHANGER		368326G01	1	1	1	1	1
20	COPPER TUBE - HOT GAS		370331G01	1	1	1	1	-
			373803G01	-	-	-	-	1
22	THERMISTOR HOLDER		436455-01	1	1	1	1	1
23	THERMISTOR	NBFC-36-H60-1	P00027-01	1	1	1	1	1
24	INSULATION - THERMISTOR		471010Z01	1	1	1	1	1
25	CABLE TIE	CV-100	7920-0002	2	2	2	2	2
26	PUSH MOUNT TIE	T30RSF	436156-01	1	1	1	1	1
27	EXPANSION VALVE	HFE-5QHD-3	P00318-01	1	1	1	1	1
28	INSULATION TUBE (A)	L=200	H73858200	1	1	1	1	1
29	SEPARATOR		250749-03	2	2	2	2	2
30	COPPER TUBE - PROCESS(A)	COPPER TUBE - PROCESS(A) 471181G01	471181M01	1	1	1	1	1
31	STARTING RELAY	MM5-E3CH	438849-01	1	1	1	1	1
32	MOTOR PROTECTOR	MST00AKZ-9040	P00363-01	1	1	1	1	1
33	PROTECTOR COVER	01-242281	P00355-01	1	1	1	1	1

HA

MODEL: <b>KM-151BAH</b>		TITLE: <b>E. REFRIGERATION CIRCUIT</b>						
INDEX NO.	DESCRIPTION	MATERIAL OR MODEL NUMBER	PART NUMBER	REQ'D NUMBER				
				S-1,S-2	S-3,T-0	T-1,U-0	U-1,V-0	V-1,E-0
34	CLAMP	01-236384	438846-01	1	1	1	1	1
35	CLIP	01-246801	438847-01	1	1	1	1	1
36	GROMMET SLEEVE	01-245960	463984-01	2	2	2	2	2
37	EXPANSION VALVE COVER		369332Z01	1	1	1	1	1
38	COPPER TUBE - DRIER		471179M01	1	1	1	1	1
39	TEE		417394-01	1	1	1	1	1
40	PRESSURE SWITCH	ACB-1UB29	463180-02	1	1	1	1	1
41	INSULATION TUBE	COPPER TUBE - PROCESS(A) 471181G01 L=100	H71020100	1	1	1	1	1
42	HOLDER - EXPV		451267-01	1	1	1	1	1
43	CLAMP		443461-01	1	1	1	1	1
44	CABLE TIE	CV-200	7920-0010	2	2	2	2	2
45	VALVE BODY	AMS - B24BH DU - 1	4A3275-01	1	1	1	1	1
46	COIL - VALVE		4A3277-01	1	1	1	1	1
47	BOLT		4A3277F01	1	1	1	1	1

HA

MODEL: <b>KM-151BAH</b>		TITLE: <b>E. REFRIGERATION CIRCUIT</b>						
INDEX NO.	DESCRIPTION	MATERIAL OR MODEL NUMBER	PART NUMBER	REQ'D NUMBER				
				E-1				
1	BASE		370284G01	1				
2	COMPRESSOR	QA125K29CAU6-E0GS	P00025-01	1				
3	RUBBER GROMMET	01-245970	463983-01	4				
4	BOLT	8x35	436206-03	2				
5	CONDENSER		P00030-01	1				
6	SHROUD		3Y2364M01	1				
7	BRACKET - FM		470291-01	1				
8	FAN MOTOR	M4Q045-CA27-04	P00466-01	1				
9	FAN BLADE	200 DIA (22°)	P00006-01	1				
10	EVAPORATOR ASSY		252014G01	-				
			258411G01	1				
12	COPPER TUBE(A) - HI		368334-01	1				
13	TEE		420041-03	1				
14	COPPER TUBE(B) - HI		470297-01	1				
15	STRAINER		P00008-01	1				
16	COPPER TUBE(C) - HI		471943M01	1				
17	COPPER TUBE(D) - HI		470295-01	1				
18	DRIER		P00026-01	1				
19	HEAT EXCHANGER		368326G01	1				
20	COPPER TUBE - HOT GAS		370331G01	-				
			373803G01	1				
22	THERMISTOR HOLDER		436455-01	1				
23	THERMISTOR	NBFC-36-H60-1	P00027-01	1				
24	INSULATION - THERMISTOR		471010Z01	1				
25	CABLE TIE	CV-100	7920-0002	2				
26	PUSH MOUNT TIE	T30RSF	436156-01	1				
27	EXPANSION VALVE	HFE-5QHD-3	P00318-01	1				
28	INSULATION TUBE (A)	L=200	H73858200	1				
29	SEPARATOR		250749-03	2				
30	COPPER TUBE - PROCESS(A)	COPPER TUBE - PROCESS(A) 471181G01	471181M01	1				
31	STARTING RELAY	MM5-E3CH	438849-01	1				
32	MOTOR PROTECTOR	MST00AKZ-9040	P00363-01	1				
33	PROTECTOR COVER	01-242281	P00355-01	1				

HA

MODEL: <b>KM-151BAH</b>		TITLE: <b>E. REFRIGERATION CIRCUIT</b>						
INDEX NO.	DESCRIPTION	MATERIAL OR MODEL NUMBER	PART NUMBER	REQ'D NUMBER				
				E-1				
34	CLAMP	01-236384	438846-01	1				
35	CLIP	01-246801	438847-01	1				
36	GROMMET SLEEVE	01-245960	463984-01	2				
37	EXPANSION VALVE COVER		369332Z01	1				
38	COPPER TUBE - DRIER		471179M01	1				
39	TEE		417394-01	1				
40	PRESSURE SWITCH	ACB-1UB29	463180-02	1				
41	INSULATION TUBE	COPPER TUBE - PROCESS(A) 471181G01 L=100	H71020100	1				
42	HOLDER - EXPV		451267-01	1				
43	CLAMP		443461-01	1				
44	CABLE TIE	CV-200	7920-0010	2				
45	VALVE BODY	AMS - B24BH DU - 1	4A3275-01	1				
46	COIL - VALVE		4A3277-01	1				
47	BOLT		4A3277F01	1				



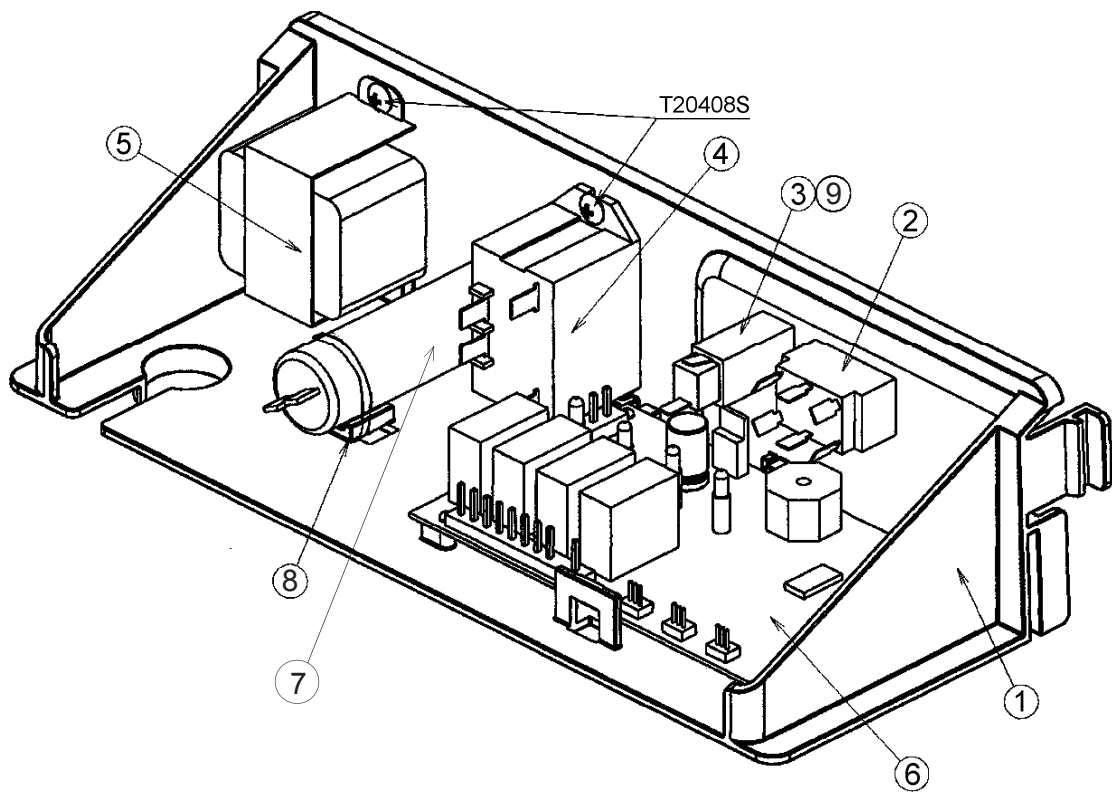

HA

MODEL: <b>KM-151BAH</b>		TITLE: <b>F. CONTROL BOX ASSY</b>						
INDEX NO.	DESCRIPTION	MATERIAL OR MODEL NUMBER	PART NUMBER	REQ'D NUMBER				
				S-1,S-2	S-3,T-0	T-1,U-0	U-1,V-0	V-1,E-0
1	CONTROL BOX		<a href="#">117624-01</a>	1	1	1	1	1
2	TOGGLE SWITCH	KND-203	<a href="#">P00033-01</a>	1	1	1	1	1
3	FUSE HOLDER	BF115	<a href="#">P00014-01</a>	1	1	1	1	1
4	POWER RELAY	G7L-1A-TUB	<a href="#">449000-01</a>	1	1	1	1	1
5	TRANSFORMER		<a href="#">3A4395-01</a>	1	1	1	1	1
6	CONTROLLER BOARD	HKM2006V003	<a href="#">P01771-02</a>	1	1	1	1	1
7	START CAPACITOR	100µF 160V	<a href="#">4Y1175-01</a>	1	1	1	1	1
8	CABLE TIE	CV-200	<a href="#">7920-0010</a>	1	1	1	1	1
9	FUSE	125/250V 5A	<a href="#">420468-02</a>	1	1	1	1	1

HA

MODEL: <b>KM-151BAH</b>		TITLE: <b>F. CONTROL BOX ASSY</b>						
INDEX NO.	DESCRIPTION	MATERIAL OR MODEL NUMBER	PART NUMBER	REQ'D NUMBER				
				E-1				
1	CONTROL BOX		<a href="#">117624-01</a>	1				
2	TOGGLE SWITCH	KND-203	<a href="#">P00033-01</a>	1				
3	FUSE HOLDER	BF115	<a href="#">P00014-01</a>	1				
4	POWER RELAY	G7L-1A-TUB	<a href="#">449000-01</a>	1				
5	TRANSFORMER		<a href="#">3A4395-01</a>	1				
6	CONTROLLER BOARD	HKM2006V003	<a href="#">P01771-02</a>	1				
7	START CAPACITOR	100µF 160V	<a href="#">4Y1175-01</a>	1				
8	CABLE TIE	CV-200	<a href="#">7920-0010</a>	1				
9	FUSE	125/250V 5A	<a href="#">420468-02</a>	1				

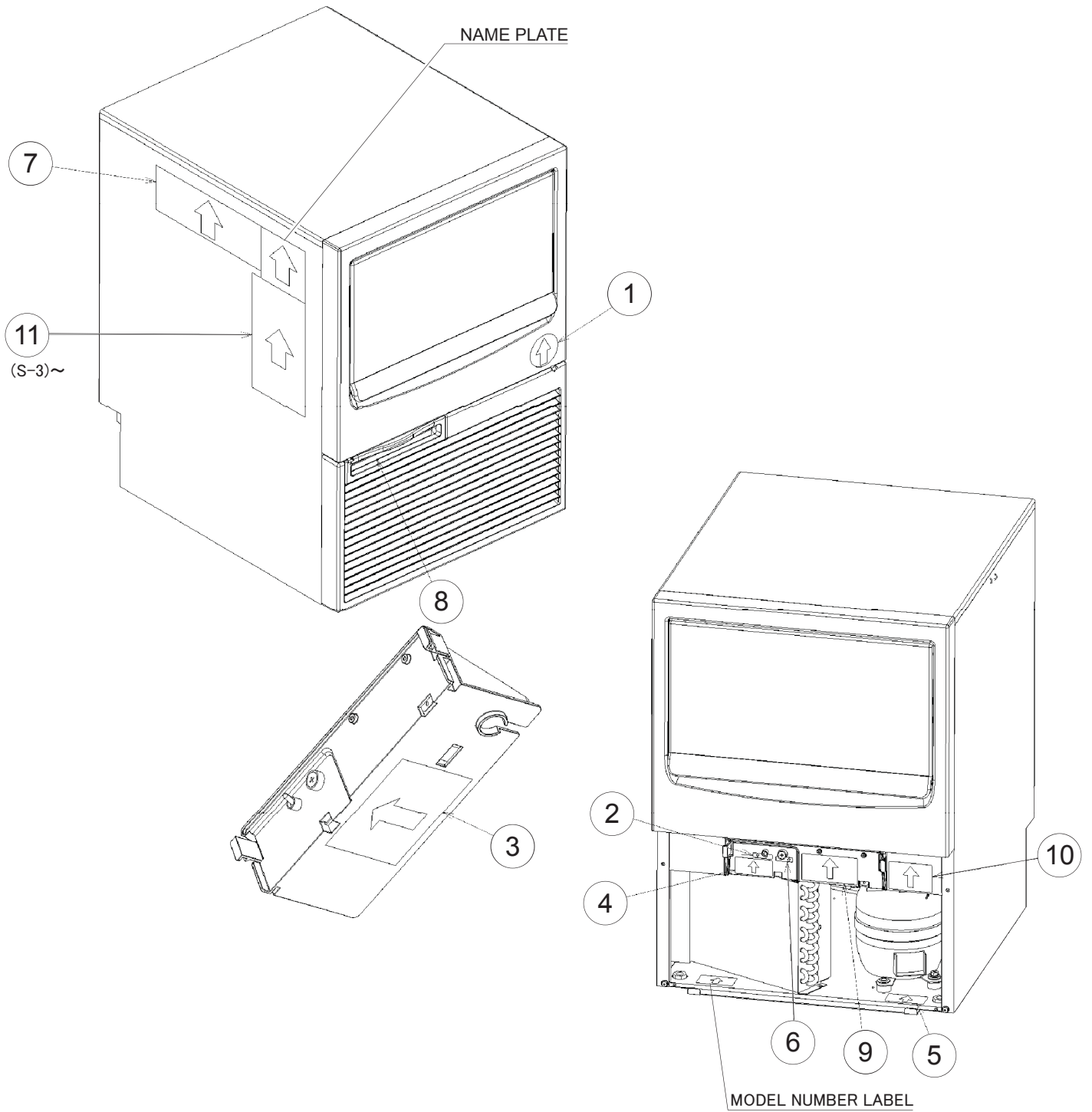

HA

MODEL: <b>KM-151BAH</b>		TITLE: <b>G. LABEL LOCATION</b>						
INDEX NO.	DESCRIPTION	MATERIAL OR MODEL NUMBER	PART NUMBER	REQ'D NUMBER				
				S-1,S-2	S-3,T-0	T-1,U-0	U-1,V-0	V-1,E-0
1	LOGO LABEL - PENGUIN		471487L01	1	1	1	1	1
2	CONTROL LABEL- FUSE		476009L01	1	1	1	1	1
3	WIRING LABEL		370657L01	1	1	1	1	1
4	CAUTION LABEL		464507-01	1	1	1	1	1
5	LABEL - R134a		444463-01	1	1	1	1	1
6	-		-	-				
7	MAINTENANCE LABEL		369056L01	1	1	1	1	1
8	LABEL - AIR FILTER		426177-01	1	1	1	1	1
9	CAUTION LABEL - SERVICE		370640L01	1	1	1	1	1
10	LABEL - ALARM		370310L01	1	1	1	1	1
11	LABEL /CONTROL BOARD		370605L02		1	1	1	1

HA

MODEL: <b>KM-151BAH</b>		TITLE: <b>G. LABEL LOCATION</b>						
INDEX NO.	DESCRIPTION	MATERIAL OR MODEL NUMBER	PART NUMBER	REQ'D NUMBER				
				E-1				
1	LOGO LABEL - PENGUIN		471487L01	1				
2	CONTROL LABEL- FUSE		476009L01	1				
3	WIRING LABEL		370657L01	1				
4	CAUTION LABEL		464507-01	1				
5	LABEL - R134a		444463-01	1				
6	-		-					
7	MAINTENANCE LABEL		369056L01	1				
8	LABEL - AIR FILTER		426177-01	1				
9	CAUTION LABEL - SERVICE		370640L01	1				
10	LABEL - ALARM		370310L01	1				
11	LABEL /CONTROL BOARD		370605L02	1				

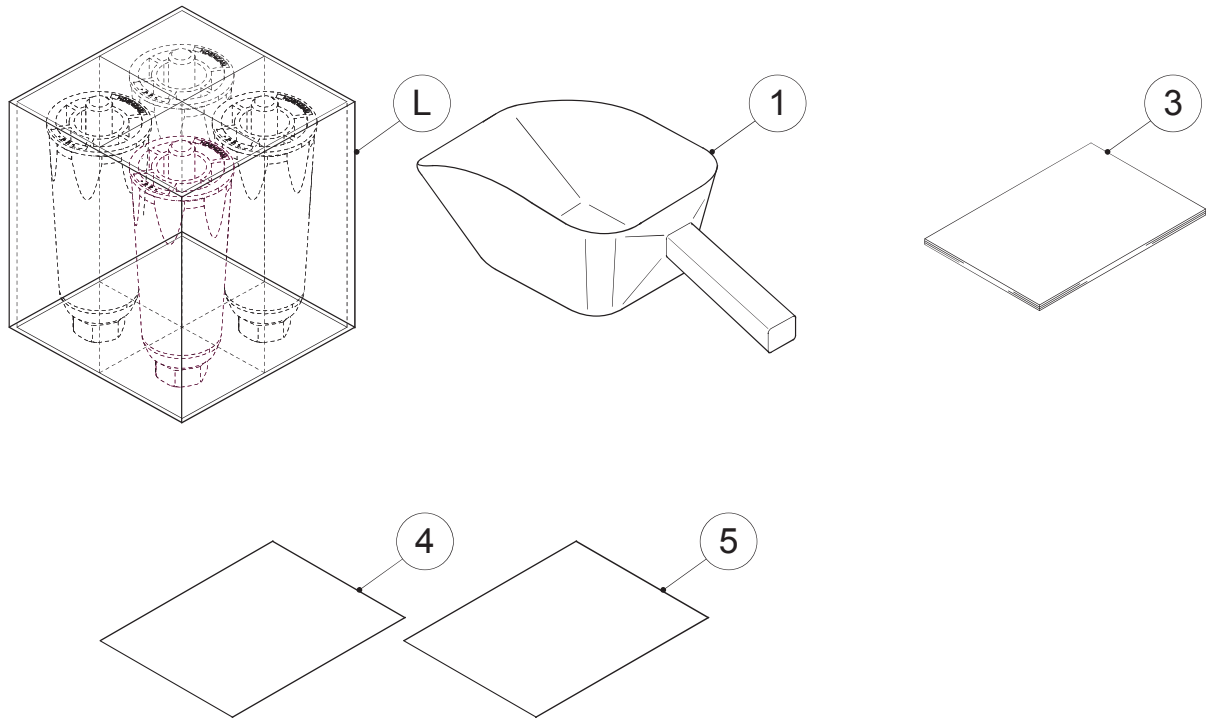

HA

MODEL: <b>KM-151BAH</b>		TITLE: <b>K. ACCESSORIES</b>						
INDEX NO.	DESCRIPTION	MATERIAL OR MODEL NUMBER	PART NUMBER	REQ'D NUMBER				
				S-1,S-2	S-3,T-0	T-1,U-0	U-1,V-0	V-1,E-0
L	LEG SET - UNC		472736A01	1	1	1	1	1
1	SCOOP		1H4123P02	1	1	1	1	1
3	INSTRUCTION MANUAL		L1M006105	1	1	1	1	1
4	WARRANTY CERTIFICATE		2A4016-01	1	1	1	1	1
5	REGISTRATION CARD		2A2894-01	1	1	1	1	1



HA

MODEL: <b>KM-151BAH</b>		TITLE: <b>K. ACCESSORIES</b>						
INDEX NO.	DESCRIPTION	MATERIAL OR MODEL NUMBER	PART NUMBER	REQ'D NUMBER				
				E-1				
L	LEG SET - UNC		472736A01	1				
1	SCOOP		1H4123P02	1				
3	INSTRUCTION MANUAL		L1M006105	1				
4	WARRANTY CERTIFICATE		2A4016-01	1				
5	REGISTRATION CARD		2A2894-01	1				

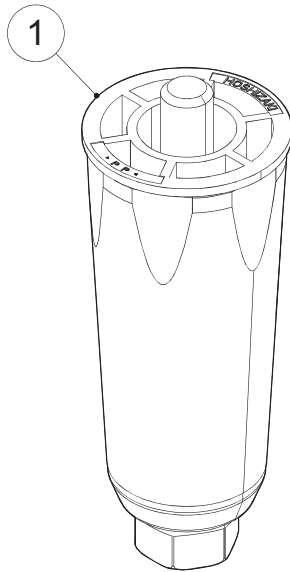

HA

MODEL: <b>KM-151BAH</b>		TITLE: <b>L. LEG SET - UNC</b>						
INDEX NO.	DESCRIPTION	MATERIAL OR MODEL NUMBER	PART NUMBER	REQ'D NUMBER				
				S-1,S-2	S-3,T-0	T-1,U-0	U-1,V-0	V-1,E-0
1	LEG - UNC		<a href="#">371053G01</a>	4	4	4	4	4

HA

MODEL: <b>KM-151BAH</b>		TITLE: <b>L. LEG SET - UNC</b>						
INDEX NO.	DESCRIPTION	MATERIAL OR MODEL NUMBER	PART NUMBER	REQ'D NUMBER				
				E-1				
1	LEG - UNC		371053G01	4				

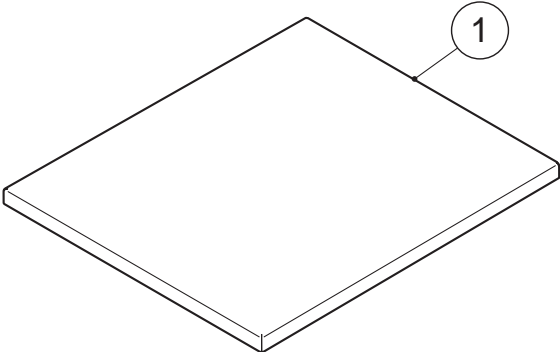

HA

MODEL: <b>KM-151BAH</b>		TITLE: <b>M. OPTIONAL PARTS</b>						
INDEX NO.	DESCRIPTION	MATERIAL OR MODEL NUMBER	PART NUMBER	REQ'D NUMBER				
				S-1,S-2	S-3,T-0	T-1,U-0	U-1,V-0	V-1,E-0
1	COVER - TOP PANEL	before serial number D02570L	266603M03	1	1	1	1	1
		serial number D02570L and later						-

HA

MODEL: <b>KM-151BAH</b>		TITLE: <b>M. OPTIONAL PARTS</b>						
INDEX NO.	DESCRIPTION	MATERIAL OR MODEL NUMBER	PART NUMBER	REQ'D NUMBER				
				E-1				
1	COVER - TOP PANEL	before serial number D02570L	266603M03	-				
		serial number D02570L and later		-				