

Hoshizaki America, Inc.

Modular Crescent Cuber

Models

KM-46 IMAH

KM-46 IMWH

KM-46 IMRH



“A Superior Degree
of Reliability”

www.hoshizaki.com

PARTS LIST



Number: 71265
Issued: 1-19-2007

CONTENTS

Auxiliary Codes.....	3
Note About Ordering Parts.....	3
Material Abbreviations.....	4
A. Ice Cuber Assembly.....	5
KM-461MAH.....	5
KM-461MWH.....	7
KM-461MRH.....	9
B. Refrigeration Circuit.....	11
KM-461MAH.....	11
KM-461MWH.....	15
KM-461MRH.....	19
C. Water Circuit.....	23
KM-461MAH, KM-461MWH, KM-461MRH.....	23
D. Control Box Assembly.....	26
KM-461MAH, KM-461MWH, KM-461MRH.....	26
E. Label Location.....	28
KM-461MAH.....	28
KM-461MWH.....	30
KM-461MRH.....	32
F. Front Panel Assembly.....	34
KM-461MAH, KM-461MWH, KM-461MRH.....	34
G. Top Panel Assembly.....	35
KM-461MAH, KM-461MWH, KM-461MRH.....	35
H. Pump Motor Assembly.....	36
KM-461MAH, KM-461MWH, KM-461MRH.....	36
J. Control Assembly.....	37
KM-461MAH, KM-461MWH, KM-461MRH.....	37
K. Accessories.....	38
KM-461MAH, KM-461MWH, KM-461MRH.....	38

Auxiliary Codes

KM-461MAH R-0 April 2006

KM-461MWH R-0 April 2006

KM-461MRH R-0 April 2006

Auxiliary Code Breakdown

K-0

- └─ Designates the year. "K" indicates the year 2000. Years progress or regress in alphabetical order. "J" is 1999, "L" is 2001, "M" is 2002, and so on. The letters "I" and "O" were skipped.
- └─ Designates significant part changes within the same year for this model. Base is 0 and this number advances for each change.

Example: P-1

- └─ "P" indicates 2004.
- └─ "1" indicates the first significant part change for 2004.

Note About Ordering Parts

Most assemblies cannot be ordered as complete units; parts in the assemblies generally must be ordered separately.

Material Abbreviations

ALUMINUM

AL = Aluminum

COPPER

CU = Copper

PLASTIC

ABS = Acrylonitrile -butadiene - styrene
AC = Polyacetal
EVA = Ethylene vinyl acetate
PA = Polyamide = Nylon
PC = Polycarbonate
PE = Polyethylene
PES = Polyester
PETP = Polyethylene terephthalate = Tetlon
PP = Polypropylene
PS = Polystyrene
PTFE = Polytetrafluoroethylene = Teflon
PUR = Polyurethane
PVC = Polyvinyl chloride

RUBBER

VN = Vinyl Nitrile
EPDM = EP rubber
NBR = Nitrile butadiene rubber
NR = Natural rubber
NP = Neoprene
SI.R = Silicone rubber
SY.R = Synthetic rubber
EPH = Epichlorohydrin

STEEL

GS = Galvanized steel
SS = Stainless steel
PS = Plated steel
PAS = Primed steel

A. Ice Cuber Assembly
KM-461MAH
 R-0

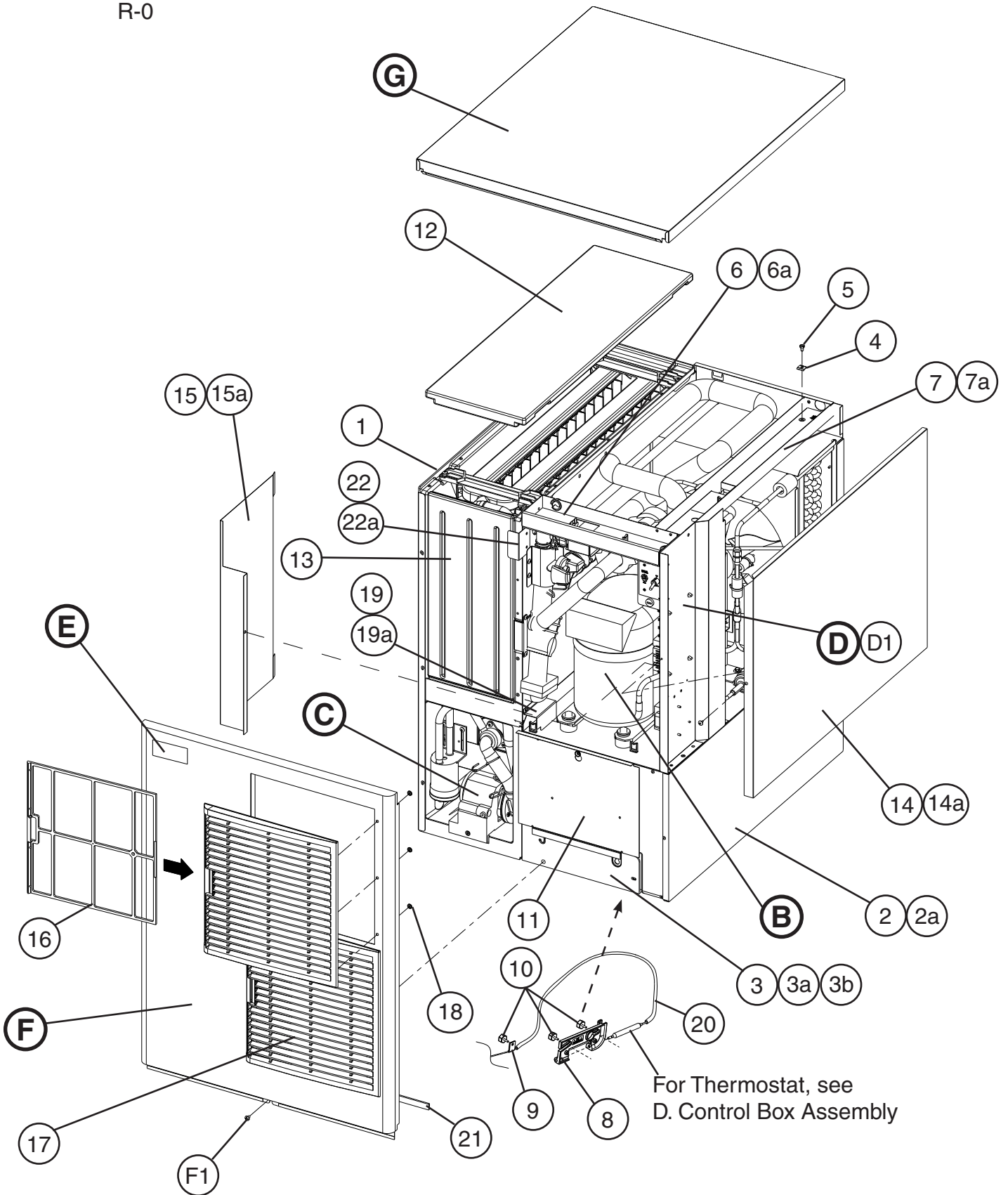

Title: A. Ice Cuber Assembly Model: KM-461MAH													
Index No.	Description	Material or Model Number	Part Number	Required Number									
				R-0									
B	Refrigeration Circuit	-	1A1133A01	1									
C	Water Circuit	-	1A0283A05	1									
D	Control Box Assembly	-	2A3765A01	1									
D1	T2 Screw	4x8	7P31-0408	4									
E	Label Location	-	3A3874A01	1									
F	Front Panel Assembly	SS	2A3767G01	1									
F1	Truss Head Screw	4x8, SS	7C32-0408	1									
G	Top Panel Assembly	SS	3A3878A01	1									
1	Evaporator Case	-	1A0579G06	1									
2	Base	-	2A2146G12	1									
2a	FT Screw	4x8	7F31-0408	7									
3	Frame	-	3A2503G01	1									
3a	Truss Head Screw	4x8, SS	7C32-0408	1									
3b	Truss Head Screw	4x25, SS	7C32-0425	2									
4	Square Washer	BRASS	433537-02	1									
5	Screw - Grounding	BRASS	433304-02	1									
6	Top Frame	GS	3A3741-01	1									
6a	T2 Screw	4x8	7P31-0408	4									
7	Side Frame	GS	3A2782-01	1									
7a	T2 Screw	4x8	7P31-0408	2									
8	Bulb Holder	-	3A3903-01	1									
9	Strap	-	435487-01	1									
10	Thumbscrew	SS, ABS	415949G10	3									
11	Base Cover	SS	321525G01	1									
12	Top Insulation	PP	215730G01	1									
13	Front Insulation	PP	215731G01	1									
14	Side Panel (R)	SS	2A2117G01	1									
14a	T2 Screw	4x8, SS	7P32-0408	1									
15	Control Box Cover	GS	3A2476-01	1									
15a	T2 Screw	4x8	7P31-0408	1									
16	Air Filter (A)	ABS	2A2062G01	2									
17	Louver (A)	ABS	1A0547-01	2									
18	Push Retainer	-	4A2414-01	6									
19	Barrier	GS	4A0362-01	1									
19a	T2 Screw	4x8	7P31-0408	2									
20	Silicone Hose	L = 670	7730I3812	1									
21	Gasket	L = 554	4A0808L02	1									
22	Barrier - Insulation	GS	4A1167-01	1									
22a	T2 Screw	4x8	7P31-0408	2									

A. Ice Cuber Assembly
KM-461MWH
 R-0

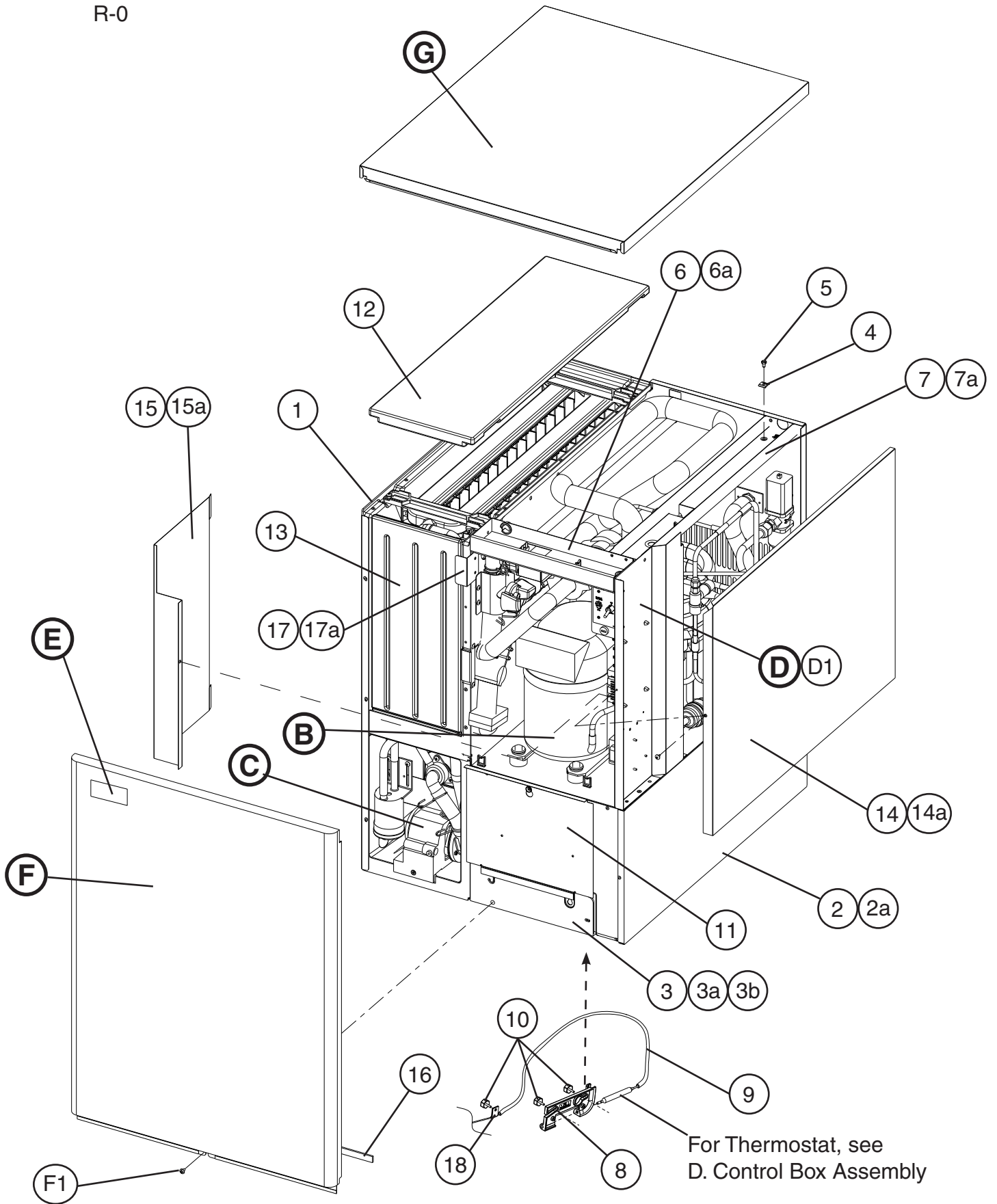

Title: **A. Ice Cuber Assembly** Model: **KM-461MWH**

Index No.	Description	Material or Model Number	Part Number	R-0	Required Number									
B	Refrigeration Circuit	-	1A1135A01	1										
C	Water Circuit	-	1A0283A05	1										
D	Control Box Assembly	-	2A3765A02	1										
D1	T2 Screw	4x8	7P31-0408	4										
E	Label Location	-	3A3875A01	1										
F	Front Panel Assembly	SS	2A2150G01	1										
F1	Truss Head Screw	4x8, SS	7C32-0408	1										
G	Top Panel Assembly		3A3878A01	1										
1	Evaporator Case	-	1A0579G06	1										
2	Base	-	2A2146G13	1										
2a	FT Screw	4x8	7F31-0408	7										
3	Frame	-	3A2503G01	1										
3a	Truss Head Screw	4x8, SS	7C32-0408	1										
3b	Truss Head Screw	4x25, SS	7C32-0425	2										
4	Square Washer	BRASS	433537-02	1										
5	Screw - Grounding	BRASS	433304-02	1										
6	Top Frame	GS	3A3741-01	1										
6a	T2 Screw	4x8	7P31-0408	4										
7	Side Frame	GS	3A2782-01	1										
7a	T2 Screw	4x8	7P31-0408	2										
8	Bulb Holder	-	3A3903-01	1										
9	Silicone Hose	L = 670	7730I3812	1										
10	Thumbscrew	SS, ABS	415949G10	3										
11	Base Cover	SS	321525G01	1										
12	Top Insulation	PP	215730G01	1										
13	Front Insulation	PP	215731G01	1										
14	Side Panel (R)	SS	2A2117G01	1										
14a	T2 Screw	4x8, SS	7P32-0408	1										
15	Control Box Cover	GS	3A2476-01	1										
15a	T2 Screw	4x8	7P31-0408	1										
16	Gasket	L = 554	4A0808L02	1										
17	Barrier – Insulation	GS	4A1167-01	1										
17a	T2 Screw	4x8	7P31-0408	2										
18	Strap	-	435487-01	1										

A. Ice Cuber Assembly
KM-461MRH
 R-0

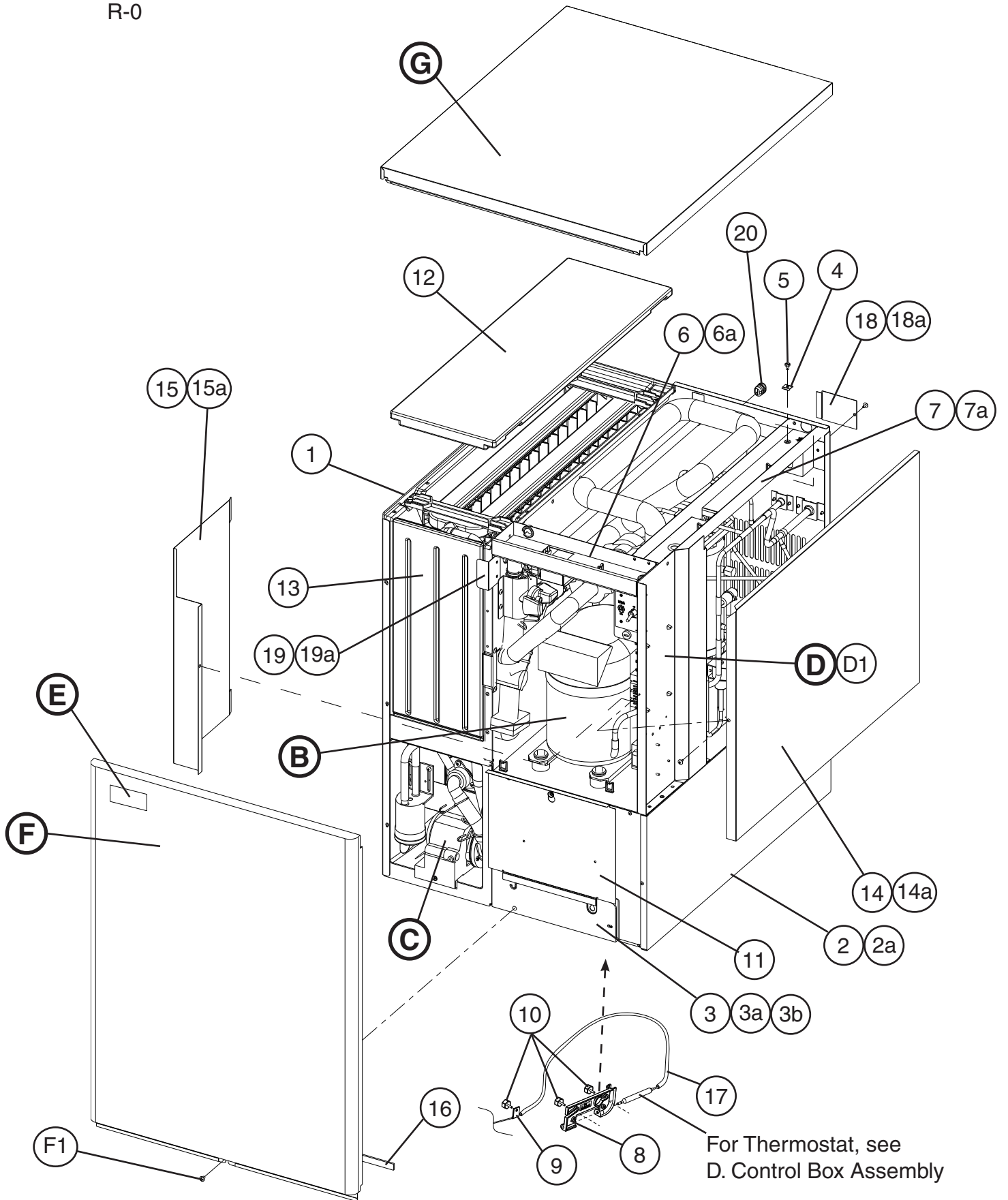

Title: A. Ice Cuber Assembly Model: KM-461MRH												
Index No.	Description	Material or Model Number	Part Number	Required Number								
				R-0								
B	Refrigeration Circuit	-	1A1137A01	1								
C	Water Circuit	-	1A0283A05	1								
D	Control Box Assembly	-	2A3765A02	1								
D1	T2 Screw	4x8	7P31-0408	4								
E	Label Location	-	3A3876A01	1								
F	Front Panel Assembly	SS	2A2150G01	1								
F1	Truss Head Screw	4x8, SS	7C32-0408	1								
G	Top Panel Assembly	SS	3A3878A01	1								
1	Evaporator Case	-	1A0579G06	1								
2	Base	-	2A2146G14	1								
2a	FT Screw	4x8	7F31-0408	7								
3	Frame	-	3A2503G01	1								
3a	Truss Head Screw	4x8, SS	7C32-0408	1								
3b	Truss Head Screw	4x25, SS	7C32-0425	2								
4	Square Washer	BRASS	433537-02	1								
5	Screw - Grounding	BRASS	433304-02	1								
6	Top Frame	GS	3A3741-01	1								
6a	T2 Screw	4x8	7P31-0408	4								
7	Side Frame	GS	3A2782-01	1								
7a	T2 Screw	4x8	7P31-0408	2								
8	Bulb Holder	-	3A3903-01	1								
9	Strap	-	435487-01	1								
10	Thumbscrew	SS, ABS	415949G10	3								
11	Base Cover	SS	321525G01	1								
12	Top Insulation	PP	215730G01	1								
13	Front Insulation	PP	215731G01	1								
14	Side Panel (R)	SS	2A2117G01	1								
14a	T2 Screw	4x8, SS	7P32-0408	1								
15	Control Box Cover	-	3A2476-01	1								
15a	T2 Screw	4x8	7P31-0408	1								
16	Gasket	L = 554	4A0808L02	1								
17	Silicone Hose	L = 670	7730I3812	1								
18	Junction Box Cover	GS	433410-01	1								
18a	T2 Screw	4x8	7P31-0408	1								
19	Barrier – Insulation	GS	4A1167-01	1								
19a	T2 Screw	4x8	7P31-0408	2								
20	Bushing	SR-30-1	420472-03	1								

B. Refrigeration Circuit

1/2

KM-461MAH

R-0

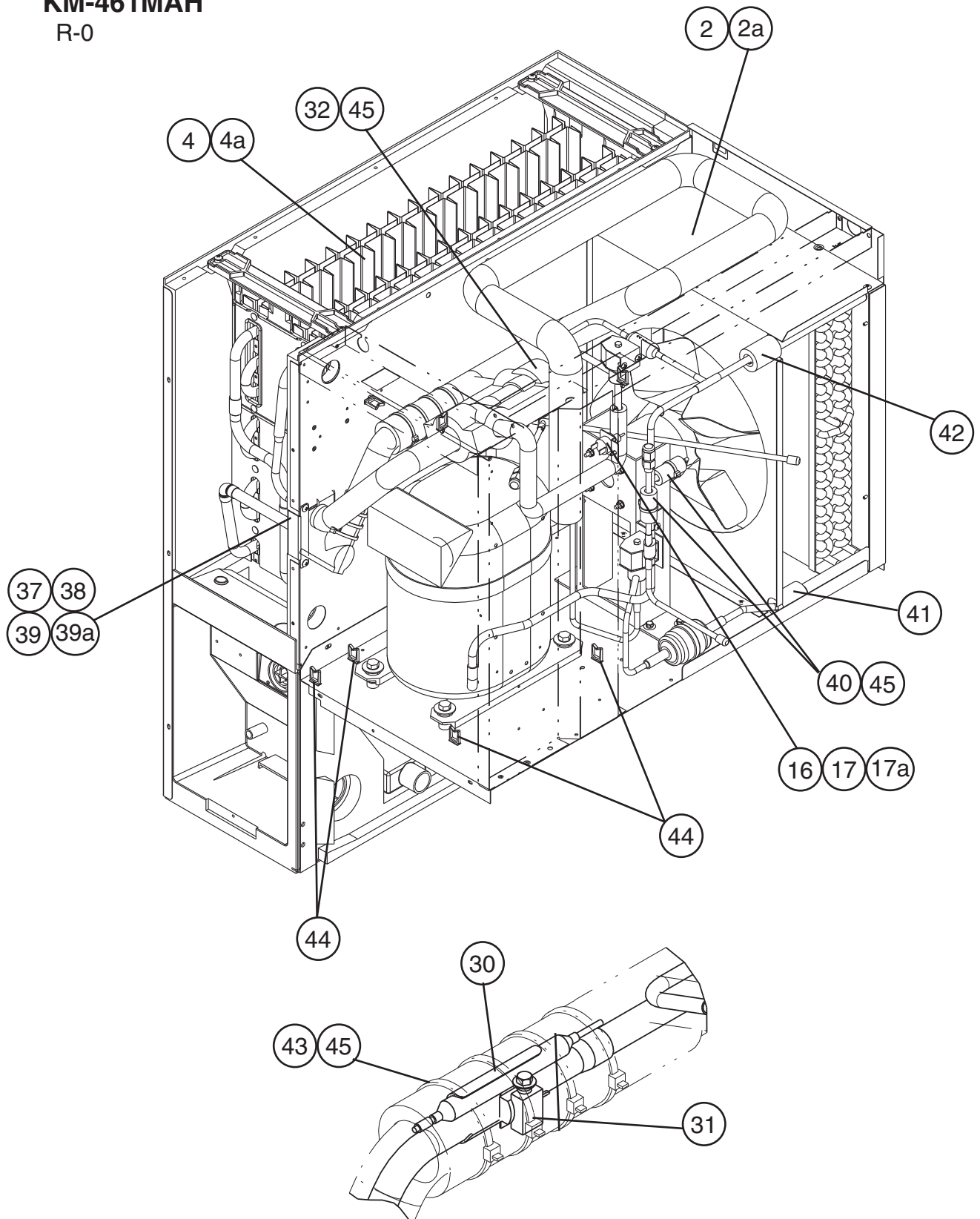

Detailed TXV Bulb Attachment

B. Refrigeration Circuit

2/2

KM-461MAH

R-0

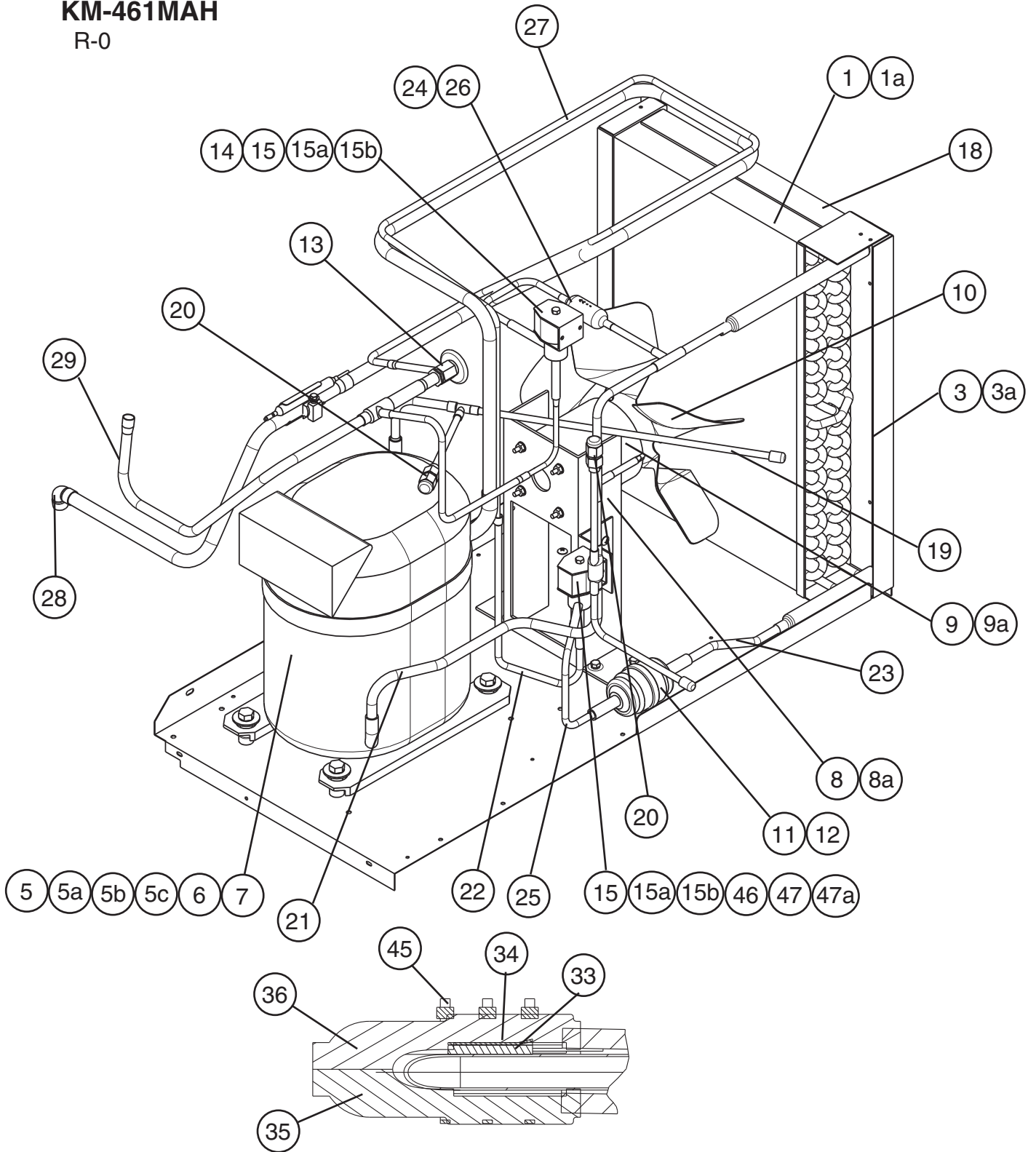

Detailed Thermistor Attachment

Title: **B. Refrigeration Circuit** Model: **KM-461MAH**

Index No.	Description	Material or Model Number	Part Number	R-0	Required Number									
1	Condenser	-	2A3756-01	1										
1a	T2 Screw	4x8	7P31-0408	2										
2	Shroud	GS	2A3760-01	1										
2a	T2 Screw	4x8	7P31-0408	5										
3	Barrier	GS	433693-04	1										
3a	T2 Screw	4x8	7P31-0408	2										
4	Evaporator	-	106492G01	1										
4a	T2 Screw	4x16, SS	7P32-0416	4										
5	Compressor	RS43C2E-CAA	4A2300-01	1										
5a	Bolt	8x45	437889-01	4										
5b	Spacer	027-0072-02	434404-01	4										
5c	Grommet	527-0039-04	434403-01	4										
6	Protector	071-0527-04	4A1805-01	1										
7	Protector Holder	-	437339-01	1										
8	Fan Motor Bracket	GS	3A3859-01	1										
8a	Hex Bolt Assembly (LF)	5x12	7B0130512	4										
9	Fan Motor	5KCP84DFK148S	4A3158-01	1										
9a	Self-locking Nut	NO. 8-32	7N2110832	4										
10	Fan Blade	AD10EECW40	4A3959-01	1										
11	Drier	C-03E126	4A2666-01	1										
12	Nylon Tie	-	8911-0301	1										
13	Expansion Valve	HFE-10NHDU-4	4A4008-01	1										
14	Valve Body - Hot Gas	-	4A3978-01	1										
15	Coil - Valve		4A3277-01	2										
15a	Bolt	4x6	4A3277F01	2										
15b	Truss Head Screw	4x8	7C31-0408	4										
16	Pressure Switch	ACB-1UB09	433441-07	1										
17	Pressure Switch Bracket	-	434938-01	1										
17a	T2 Screw	4x8	7P31-0408	1										
18	Gasket	L = 245	4A0808L01	2										
19	Copper Tube Access Valve	COPPER	3A3857G01	1										
20	Access Valve	-	457729-01	2										
21	Copper Tube (A) - High Side	COPPER	2A3757G01	1										
22	Copper Tube (B) - High Side	COPPER	4A3962-01	1										
23	Copper Tube (C) - High Side	COPPER	4A3961-01	1										
24	Copper Tube (D) - High Side	COPPER	3A3855G01	1										
25	Copper Tube (E) - High Side	COPPER	3A3905-01											
26	Strainer	(included in item 24: 3A3855G01)	441569-01	1										
27	Heat Exchanger	-	2A4043G01	1										
28	Elbow	COPPER	417395-03	1										
29	Copper Tube - Hot Gas	COPPER	2A4099G01	1										
30	Holder / Exp. Valve – 3/8	SS	3A0107-01	1										
31	Clamp	SS	443461-02	1										

Title: **B. Refrigeration Circuit** Model: **KM-461MAH**

Index No.	Description	Material or Model Number	Part Number	Required Number									
				R-0									
32	Expansion Valve Cover	PE FOAM	3A0944-01	1									
33	Thermistor	-	429006-03	1									
34	Holder - Thermistor	COPPER	427430-01	1									
35	Insulation - Thermistor (A)	PE FOAM	439368-01	1									
36	Insulation - Thermistor (B)	PE FOAM	439368-02	1									
37	Rubber Insulation (A)	EPDM	3A1044-01	1									
38	Rubber Insulation (B)	EPDM	3A1045-01	1									
39	Insulation Holder	-	4A1550-01	1									
39a	T2 Screw	4x8, SS	7P32-0408	2									
40	Insulation Tube	L = 40	7762-1020	2									
41	Insulation Tube	L = 40	7762-1030	1									
42	Insulation Tube	L = 40	7762-1630	1									
43	Insulation Tube	L = 150	7762-2943	1									
44	Wire Saddle	VWS4238-C	4A0338-02	8									
45	Cable Tie	CV-200 (PLT-2M)	8911-0200	12									
46	Valve Body - Liquid Line	-	4A3276-01	1									
47	Line Valve Bracket	-	4A4011-01	1									
47a	T2 Screw	4x8	7P31-0408	2									

B. Refrigeration Circuit

1/2

KM-461MWH

R-0

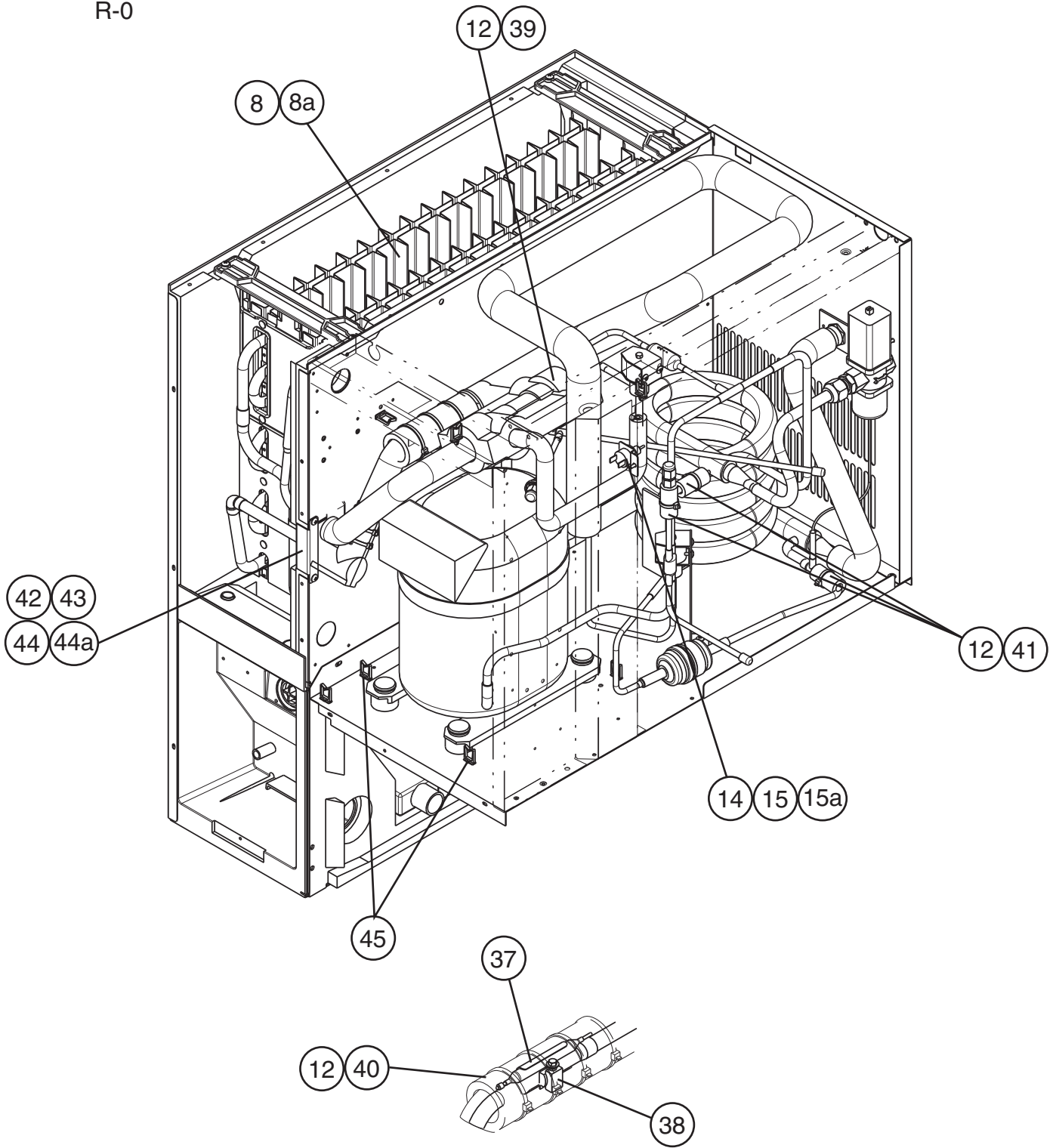

Detailed TXV Bulb Attachment

B. Refrigeration Circuit
2/2
KM-461MWH
 R-0

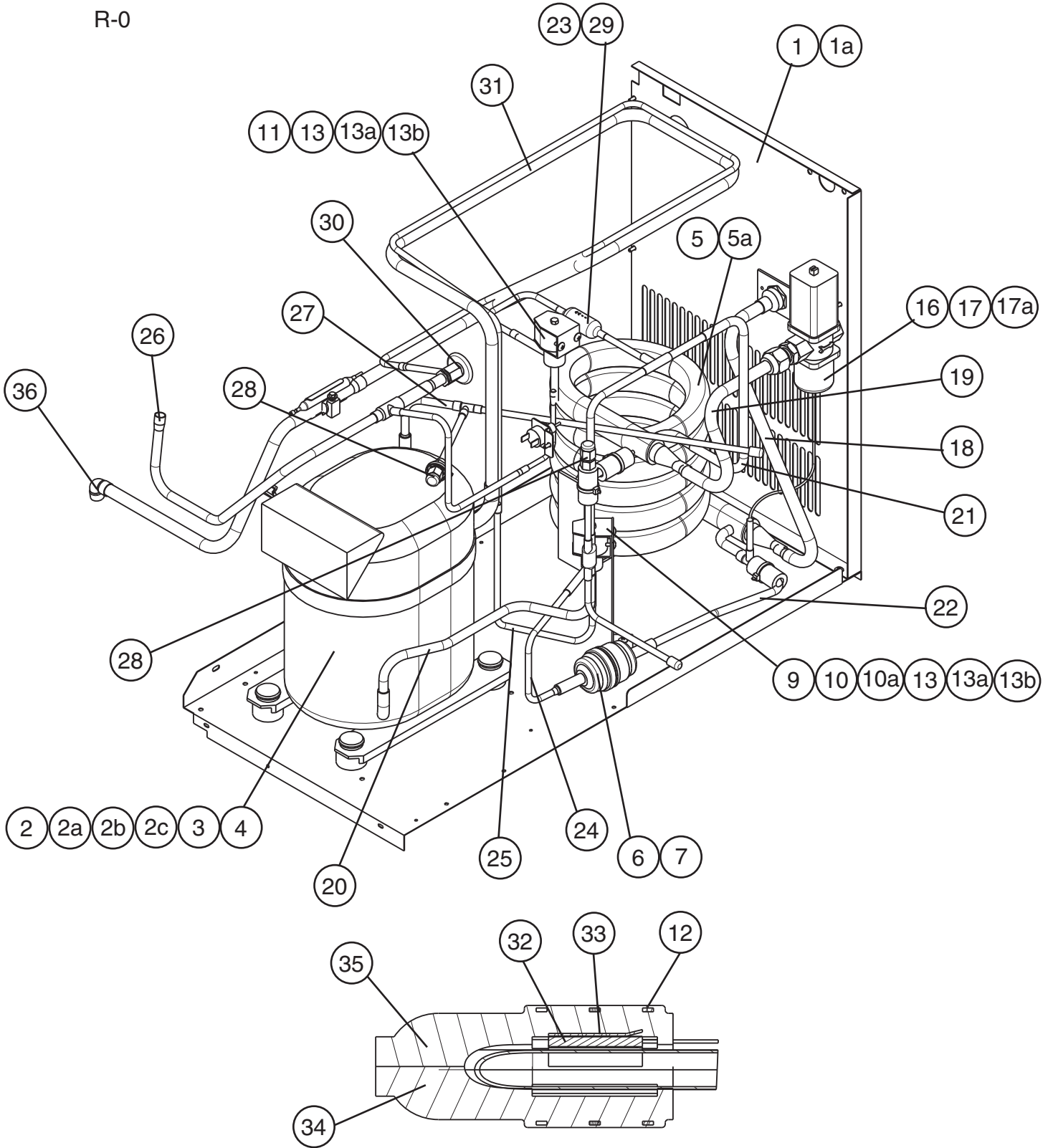

Detailed Thermistor Attachment

Title: **B. Refrigeration Circuit** Model: **KM-461MWH**

Index No.	Description	Material or Model Number	Part Number	R-0	Required Number									
1	Rear Panel	GS	2A1426-01	1										
1a	T2 Screw	4x8	7P31-0408	5										
2	Compressor	RS43C2E-CAA	4A2300-01	1										
2a	Bolt	8x45	437889-01	4										
2b	Spacer	027-0072-02	434404-01	4										
2c	Grommet	027-0073-00	434403-01	4										
3	Protector	-	4A1805-01	1										
4	Protector Holder	-	437339-01	1										
5	Condenser - Water-Cooled	-	2A3759-01	1										
5a	Hex Bolt Assembly (LF)	8x20	7B0130820	2										
6	Drier	C-03E 126	4A2666-01	1										
7	Nylon Tie	NYLON	8911-0301	1										
8	Evaporator	-	106492G01	1										
8a	T2 Screw	4x16, SS	7P32-0416	4										
9	Valve Body - Liquid Line	-	4A3276-01	1										
10	Valve - Bracket	-	436893-01	1										
10a	T2 Screw	4x8	7P31-0408	2										
11	Valve Body - Hot Gas	-	4A3978-01	1										
12	Cable Tie	PLT-2M	8911-0200	14										
13	Coil - Valve	AMS-C12HDU-3	4A3277-01	2										
13a	Bolt	-	4A3277F01	2										
13b	Truss Head Screw	4x8	7C31-0408	4										
14	Pressure Switch	ACB-2UB04	433441-05	1										
15	Pressure Switch Bracket	GS	434938-01	1										
15a	T2 Screw	4x8	7P31-0408	1										
16	Male Connector	-	4A1087-01	1										
17	Water Regulator	V46DA-5	4A0911-06	1										
17a	Truss Head Screw	4x6	7C31-0406	2										
18	Copper Tube (A) - Water Circuit	COPPER	4A3966G01	1										
19	Copper Tube (B) - Water Circuit	COPPER	3A3863G01	1										
20	Copper Tube (A) - High Side	COPPER	2A3757G01	1										
21	Copper Tube (B) - High Side	COPPER	3A3864-01	1										
22	Copper Tube (C) - High Side	COPPER	4A3974G01	1										
23	Copper Tube (D) - High Side	COPPER	3A3855G01	1										
24	Copper Tube (E) - High Side	COPPER	3A3541-01	1										
25	Copper Tube (F) - High Side	COPPER	4A3971-01	1										
26	Copper Tube - Hot Gas	COPPER	2A4099G01	1										
27	Copper Tube – Access Valve	-	3A3857G01	1										
28	Access Valve	TCJ-2F20NHDU-1	457729-01	2										
29	Strainer	(Included in item 23: 3A3855G01)	441569-01	1										
30	Expansion Valve	HFE-10NHDU-4	4A4008-01	1										
31	Heat Exchanger	-	2A4043G01	1										
32	Thermistor	-	429006-03	1										
33	Holder - Thermistor	-	427430-01	1										

Title: B. Refrigeration Circuit Model: KM-461MWH												
Index No.	Description	Material or Model Number	Part Number	Required Number								
				R-0								
34	Insulation - Thermistor (A)	PE FOAM	439368-01	1								
35	Insulation - Thermistor (B)	PE FOAM	439368-02	1								
36	Elbow	COPPER	417395-03	1								
37	Holder/Expansion Valve - 3/8	-	3A0107-01	1								
38	Clamp	SS	443461-02	1								
39	Expansion Valve Cover	PE FOAM	3A0944-01	1								
40	Insulation Tube	L = 150	7762-2943	1								
41	Insulation Tube	L = 40	7762-1020	3								
42	Rubber Insulation (A)	EPDM	3A1044-01	1								
43	Rubber Insulation (B)	EPDM	3A1045-01	1								
44	Insulation Holder	-	4A1550-01	1								
44a	T2 Screw	4x8, SS	7P32-0408	2								
45	Wire Saddle	-	4A0338-02	8								

B. Refrigeration Circuit
1/2
KM-461MRH
R-0

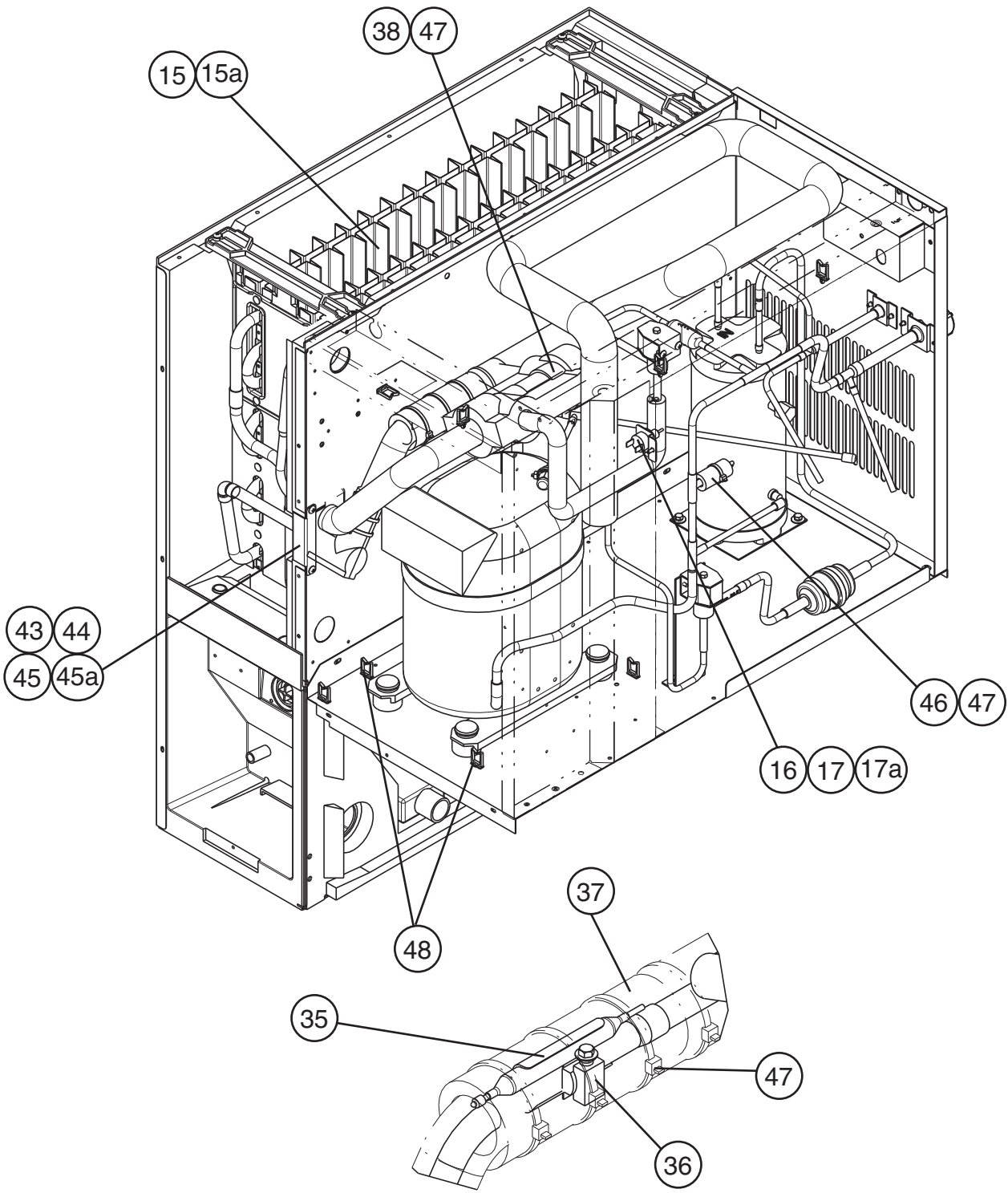

Detailed TXV Bulb Attachment

B. Refrigeration Circuit

2/2

KM-461MRH

R-0

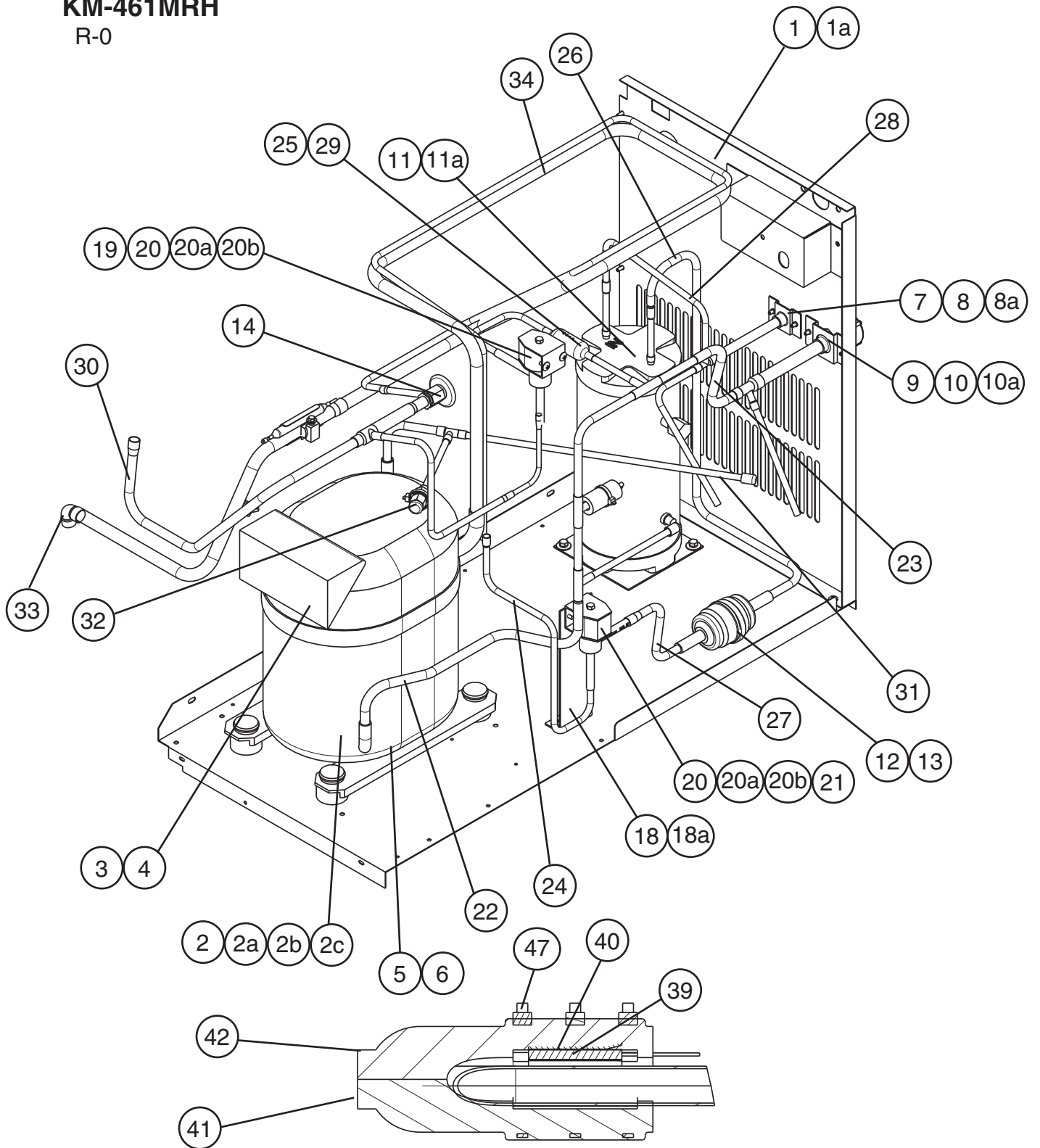

Detailed Thermistor Attachment

Title: **B. Refrigeration Circuit** Model: **KM-461MRH**

Index No.	Description	Material or Model Number	Part Number	Required Number																
				R-0																
1	Rear Panel	GS	220468G03	1																
1a	T2 Screw	4x8	7P31-0408	5																
2	Compressor	RS43C2E-CAA	4A2300-01	1																
2a	Bolt	8x45	437889-01	4																
2b	Spacer	027-0072-02	434404-01	4																
2c	Grommet	527-0073-00	434403-01	4																
3	Protector	-	4A1805-01	1																
4	Protector Holder	-	437339-01	1																
5	Crankcase Heater	-	4A1869-01	1																
6	Silicone Hose	L = 20	7730-0912	1																
7	Coupling	-	4A3972G01	1																
8	Tube Holder-S	-	438246-01	1																
8a	T2 Screw	4x8	7P31-0408	2																
9	Coupling	-	434136G01	1																
10	Tube Holder-L	-	438245-01	1																
10a	T2 Screw	4x8	7P31-0408	2																
11	Receiver Tank	RR KN WP450	437596-01	1																
11a	Hex Bolt Assembly (LF)	5x10, SS	7B0230510	3																
12	Drier	-	4A2666-01	1																
13	Nylon Tie	-	8911-0301	1																
14	Expansion Valve	HFE-10NHDU-4	4A4008-01	1																
15	Evaporator	-	106492G01	1																
15a	T2 Screw	4x16, SS	7P32-0416	4																
16	Pressure Switch	ACB-1UB09	433441-07	1																
17	Pressure Switch Bracket	GS	434938-01	1																
17a	T2 Screw	4x8	7P31-0408	1																
18	Valve Bracket	-	436893-01	1																
18a	T2 Screw	4x8	7P31-0408	2																
19	Valve Body - Hot Gas	70	4A3978-01	1																
20	Coil - Valve	AMS-C12HDU-3	4A3277-01	2																
20a	Bolt	4x6	4A3277F01	2																
20b	Truss Head Screw	4x8	7C31-0408	4																
21	Valve Body - Liquid Line	-	4A3276-01	1																
22	Copper Tube (A) - High Side	COPPER	2A3779G01	1																
23	Copper Tube (B) - High Side	COPPER	3A3867G01	1																
24	Copper Tube (C) - High Side	COPPER	3A3973-01	1																
25	Copper Tube (D) - High Side	COPPER	3A3855G01	1																
26	Copper Tube (E) - High Side	COPPER	332445-01	1																
27	Copper Tube (F) - High Side	COPPER	4A2768-01	1																
28	Copper Tube (G) - High Side	COPPER	3A3868G01	1																
29	Strainer	(Included in item 25: 3A3855G01)	441569-01	1																
30	Copper Tube - Hot Gas	COPPER	2A4099G01	1																
31	Copper Tube - Access Valve	COPPER	3A3857G01	1																
32	Access Valve	-	457729-01	1																

Title: **B. Refrigeration Circuit** Model: **KM-461MRH**

Index No.	Description	Material or Model Number	Part Number	Required Number									
				R-0									
33	Elbow	COPPER	417395-03	1									
34	Heat Exchanger	-	2A4043G01	1									
35	Holder - Expansion Valve – 3/8	SS	3A0107-01	1									
36	Clamp	-	443461-02	1									
37	Insulation Tube	L = 150	7762-2943	1									
38	Expansion Valve Cover	PE FOAM	3A0944-01	1									
39	Thermistor	-	429006-03	1									
40	Holder - Thermistor	COPPER	427430-01	1									
41	Insulation - Thermistor (A)	PE FOAM	439368-01	1									
42	Insulation - Thermistor (B)	PE FOAM	439368-02	1									
43	Rubber Insulation (A)	EPDM	3A1044-01	1									
44	Rubber Insulation (B)	EPDM	3A1045-01	1									
45	Insulation Holder	-	4A1550-01	1									
45a	T2 Screw	4x8, SS	7P32-0408	2									
46	Insulation Tube	L = 40	7762-1020	1									
47	Cable Tie	-	8911-0200	12									
48	Wire Saddle	VWS4238-C	4A0338-02	9									

C. Water Circuit
KM-461MAH, KM-461MWH, KM-461MRH
 R-0

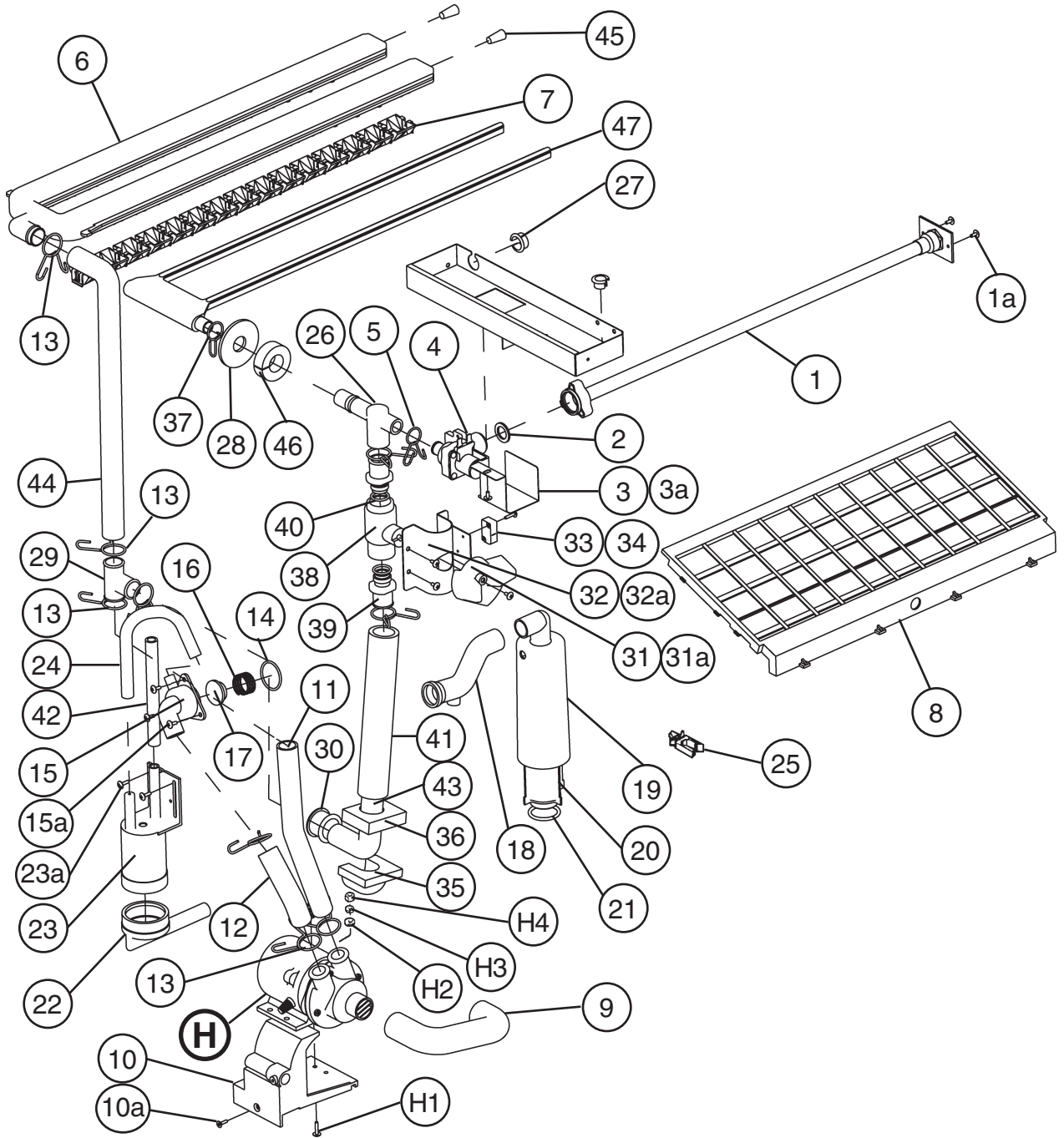

Title: **C. Water Circuit** Model: **KM-461MAH, KM-461MWH, KM-461MRH**

Index No.	Description	Material or Model Number	Part Number	Required Number									
				R-0									
H	Pump Motor Assembly	HS-0176	3A2638A03	1									
H1	Truss Head Screw	4x16, SS	7C32-0416	1									
H2	Flat Washer	M4, SS	7W22-0400	1									
H3	Split Lock Washer	M4, SS	7L22-0400	1									
H4	Hex Nut	M4, SS	7N12-0400	1									
1	Water Supply Pipe	COPPER	4A0768G04	1									
1a	T2 Screw	4x8	7P31-0408	2									
2	Rubber Gasket	NR	413854-03	1									
3	Water Valve Bracket	GS	321443-01	1									
3a	T2 Screw	4x8	7P31-0408	1									
4	Water Valve	J248-072	3U0111-04	1									
5	Hose Clamp	SS, 18MM	427443-05	1									
6	Spray Tube	PE	1A0260-02	1									
7	Spray Guide (A)	PE	208586-01	6									
8	Cube Guide	ABS	212088-01	1									
9	Suction Hose	EPDM	433466-01	1									
10	Pump Motor Bracket	PC	211408-01	1									
10a	Flat Head Screw	4x12, SS	7F32-0412	1									
11	Vinyl Hose	L = 250	7716-2025	1									
12	Vinyl Hose	L = 110	7716-2025	1									
13	Hose Clamp	SS, 25MM	427443-03	9									
14	"O" Ring	1AG35	7611-G035	1									
15	Valve Housing - Drain	ABS	321001-01	1									
15a	T2 Screw	4x10, SS	7P32-0410	3									
16	Spring	SS	322110-01	1									
17	Valve Seat	EPDM	433705-01	1									
18	Drain Hose	SANTO-PRENE	433468-01	1									
19	Overflow Cap	PE	321002-01	1									
20	Overflow Pipe	ABS	430722-03	1									
21	"O" Ring	EPDM	4A1234-01	1									
22	Connector – Float Switch	EPDM	426799-01	1									
23	Float Switch	-	4A3624-01	1									
23a	T2 Screw	4x12, SS	7P32-0412	2									
24	Silicone Hose	L = 140	773013896	1									
25	Wire Saddle	VWS4238-C	4A0338-02	4									
26	Tee	SANTO-PRENE	4A0177-01	1									
27	Bushing	OCB-750	428394-01	1									
28	Flange	EPDM	439267-01	1									
29	Distributor	EPDM	432426-01	1									
30	Rubber Ring	EPDM	439236-01	1									
31	Handle	JH1352	215383-01	1									
31a	T2 Screw	4x8	7P31-0408	1									

Title: **C. Water Circuit** Model: **KM-461MAH, KM-461MWH, KM-461MRH**

Index No.	Description	Material or Model Number	Part Number	R-0	Required Number									
32	Valve Holder	GS	3A1178-01	1										
32a	FT Screw	4x8	7F31-0408	3										
33	Microswitch	V7-1C17D8-207	4A2546-01	1										
34	Tapping Screw	3x14	431415-02	2										
35	Corner Insulation (A)	PE FOAM	439376-01	1										
36	Corner Insulation (B)	PE FOAM	439392-01	1										
37	Hose Clamp	SS, 20 MM	427443-06	1										
38	Ball Valve (Included in S-0761)	PVC	439293-01	1										
39	Male Adaptor (Included in S-0761)	ABS	325826-01	2										
40	"O" Ring (Included in S-0761)	1AP18	7611-P018	2										
41	Insulation Tube	L = 190	7762-2636	1										
42	Silicone Hose	L = 140	773013812	1										
43	Rubber Hose (D)	EPDM	4A1551-04	1										
44	Rubber Hose (C)	SANTO-PRENE	4A1551-03	1										
45	Plug	EPDM	4A0176-01	2										
46	Insulation (E)	PE FOAM	4A0392-01	1										
47	Water Supply Tube	PE	2A0079-01	1										

D. Control Box Assembly
KM-461MAH, KM-461MWH, KM-461MRH
R-0

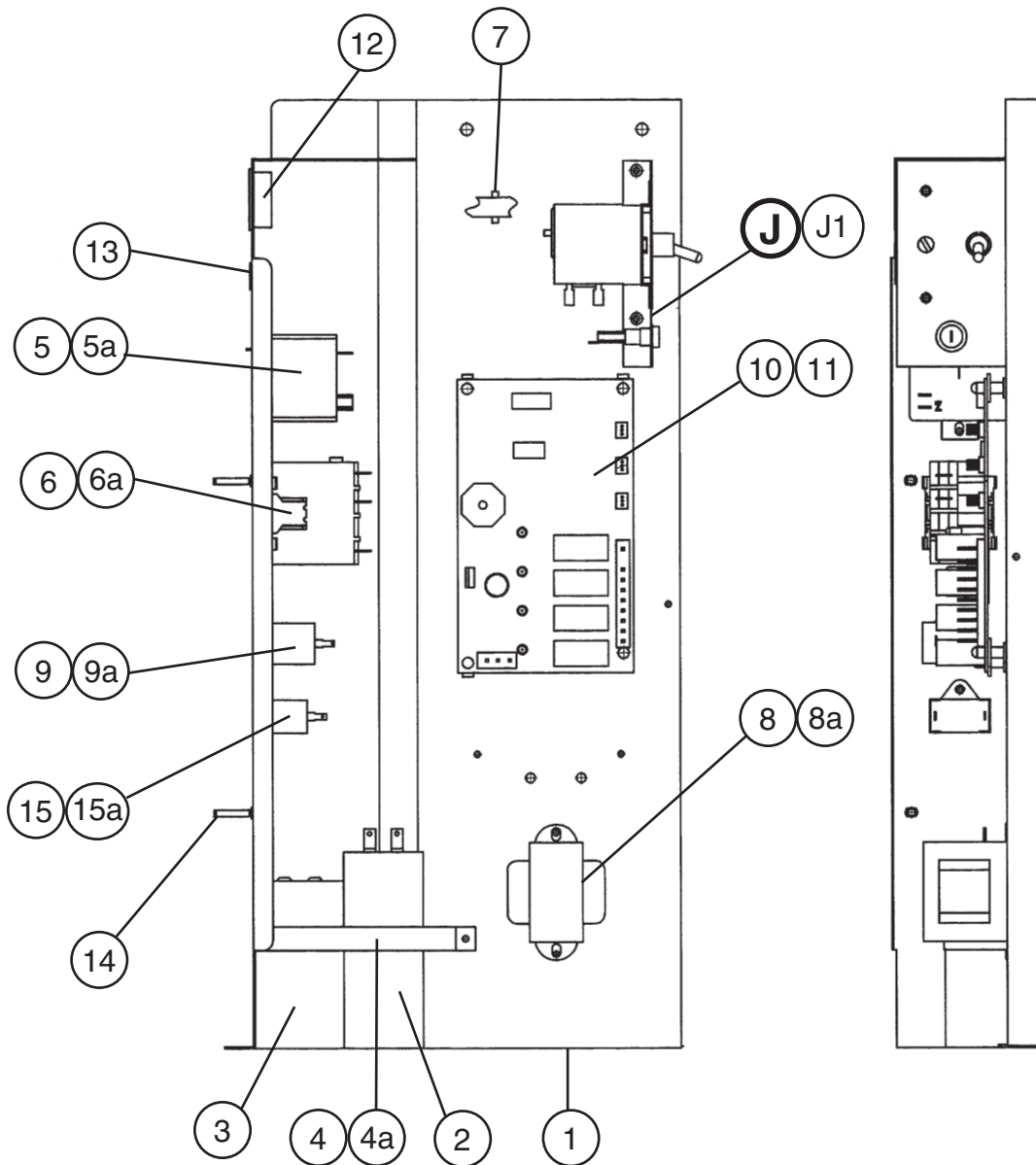

Title: **D. Control Box Assembly** Model: **KM-461MAH, KM-461MWH, KM-461MRH**

Index No.	Description	Material or Model Number	Part Number	Required Number									
				R-0									
J	Control Assembly	-	4A2911A01	1									
J1	T2 Screw	4x8	7P31-0408	2									
1	Control Box	-	2A1851-01	1									
2	Capacitor – Run	15MFD, 370 VAC	3A2005-08	1									
3	Capacitor – Starting	243-292 MFD 115V	3A0076-10	1									
4	Strap	GS	4A2262-03	1									
4a	T2 Screw	4x8	7P31-0408	1									
5	Starter	3ARR3CT5M5	4A1107-11	1									
5a	T2 Screw	4x8	7P31-0408	1									
6	Magnetic Contactor	VC-20	428393-01	1									
6a	T2 Screw	4x8	7P31-0408	2									
7	Fuse (Spare)	-	4A0893-07	1									
8	Transformer	26D285H	3A0172-01	1									
8a	T2 Screw	4x8	7P31-0408	2									
9	Capacitor - Pump Motor	5.5 MFD 250VAC	443192-03	1									
9a	T2 Screw	4x10	7P31-0410	1									
10	Controller Board	-	2A1410-01	1									
11	Board Support	CBLS37-M	4A0336-03	4									
12	Bushing	SB-1093-15	420470-03	1									
13	Bushing	OCB-500	428394-02	1									
14	Clamp	-	4A2338-01	2									
15	Capacitor (KM-461MAH Only)	5 MFD, 250VAC	443192-02	1									
15a	T2 Screw (KM-461MAH Only)	4x10	7P31-0410	1									

E. Label Location
KM-461MAH
R-0

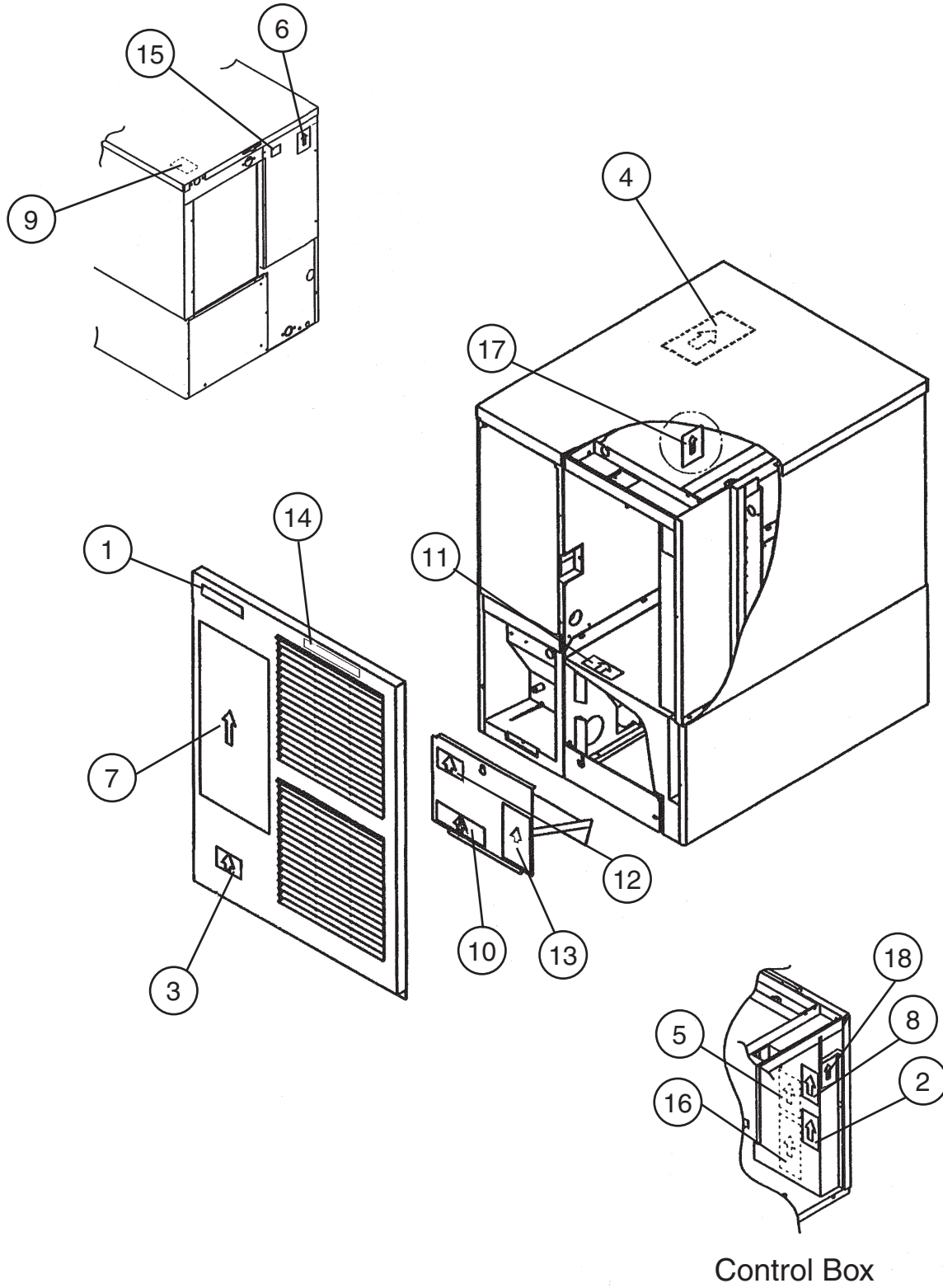

Title: **E. Label Location** Model: **KM-461MAH**

Index No.	Description	Material or Model Number	Part Number	Required Number																
				R-0																
1	Emblem	PETP FILM	4A0560-01	1																
2	Label - Alarm	-	4A3517-01	1																
3	Label – Penguin – HA (R)	PETP FILM	4A0526-01	1																
4	Maintenance Label	PVC FILM	326218-01	1																
5	Wiring Label	PVC FILM	3A3888-01	1																
6	Nameplate	PES FILM	2A3771-01	1																
7	Instruction Sheet	PAPER	2A3807-01	1																
8	Manual Label	PVC FILM	446564-01	1																
9	Tag – Warning: Electrical Connection	PAPER	435005-01	1																
10	Operation Label – Valve	PVC FILM	439541-01	1																
11	Label – R404A	PES FILM	4A0960-01	1																
12	Caution Label (F)	PVC FILM	439146-01	1																
13	Caution Label (H)	PVC FILM	439148-01	1																
14	Label – Air Filter	PETP FILM	426177-01	1																
15	Instruction Label	PVC FILM	444575-01	1																
16	Label – Control Board	PVC FILM	3A2220-01	1																
17	Rating Label	-	2A3772-01	1																
18	Label – Fuse	-	4A2817-01	1																

E. Label Location
KM-461MWH
R-0

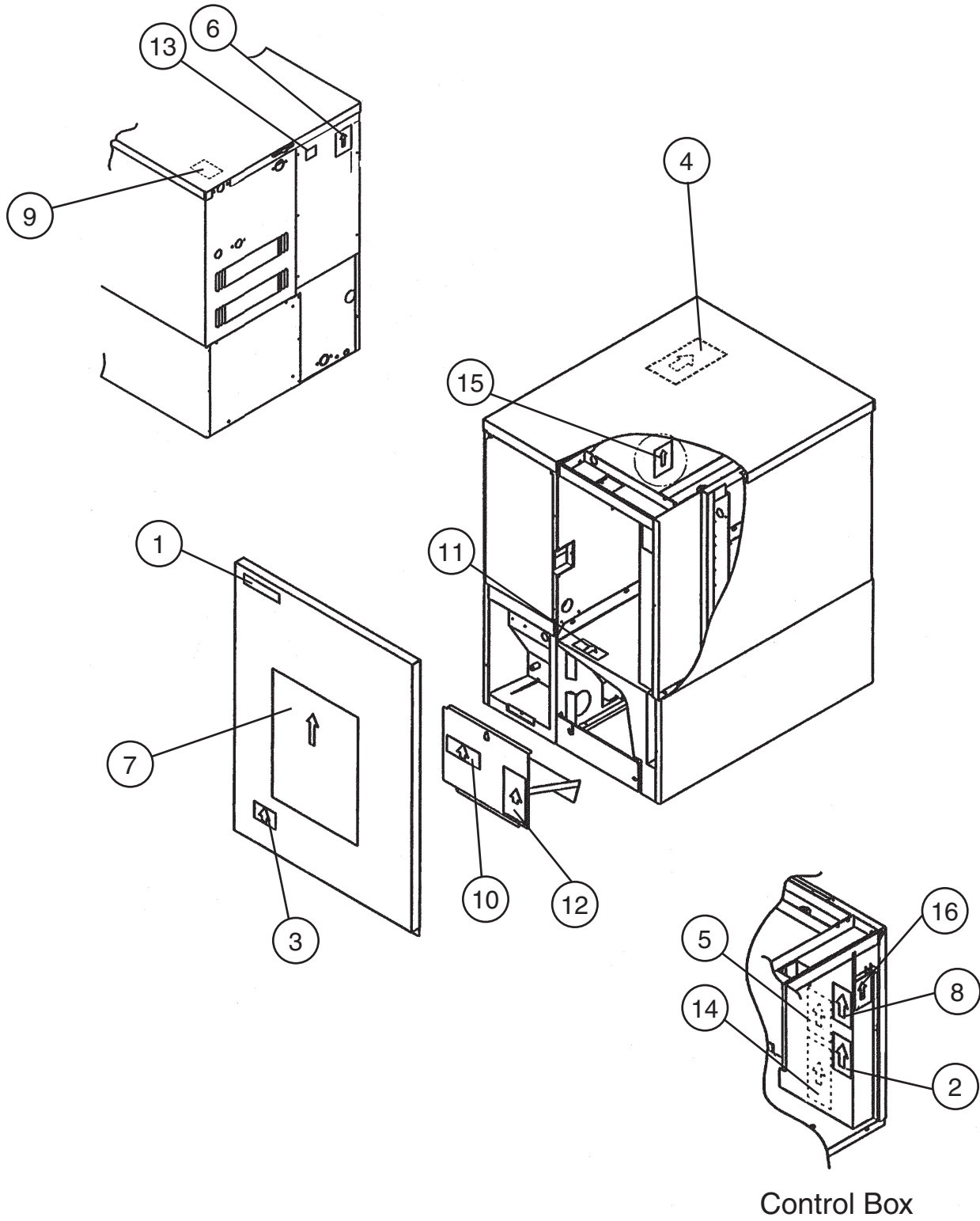

Title: **E. Label Location** Model: **KM-461MWH**

Index No.	Description	Material or Model Number	Part Number	Required Number											
				R-0											
1	Emblem	PETP FILM	4A0560-01	1											
2	Label - Alarm	PETP FILM	4A3517-01	1											
3	Label – Penguin – HA (R)	PETP FILM	4A0526-01	1											
4	Maintenance Label	PVC FILM	326218-01	1											
5	Wiring Label	PVC FILM	3A3888-01	1											
6	Nameplate	PES FILM	2A3771-02	1											
7	Instruction Sheet	PAPER	2A3807-01	1											
8	Manual Label	PVC FILM	446564-01	1											
9	Tag – Warning: Electrical Connection	PAPER	435005-01	1											
10	Operation Label – Valve	PVC FILM	439541-01	1											
11	Label – R404A	PES FILM	4A0960-01	1											
12	Caution Label (H)	PVC FILM	439148-01	1											
13	Instruction Label	PVC FILM	444575-01	1											
14	Label – Control Board	PVC FILM	3A2220-01	1											
15	Rating Label	-	2A3772-02	1											
16	Label – Fuse	-	4A2817-01	1											

E. Label Location
KM-461MRH
 R-0

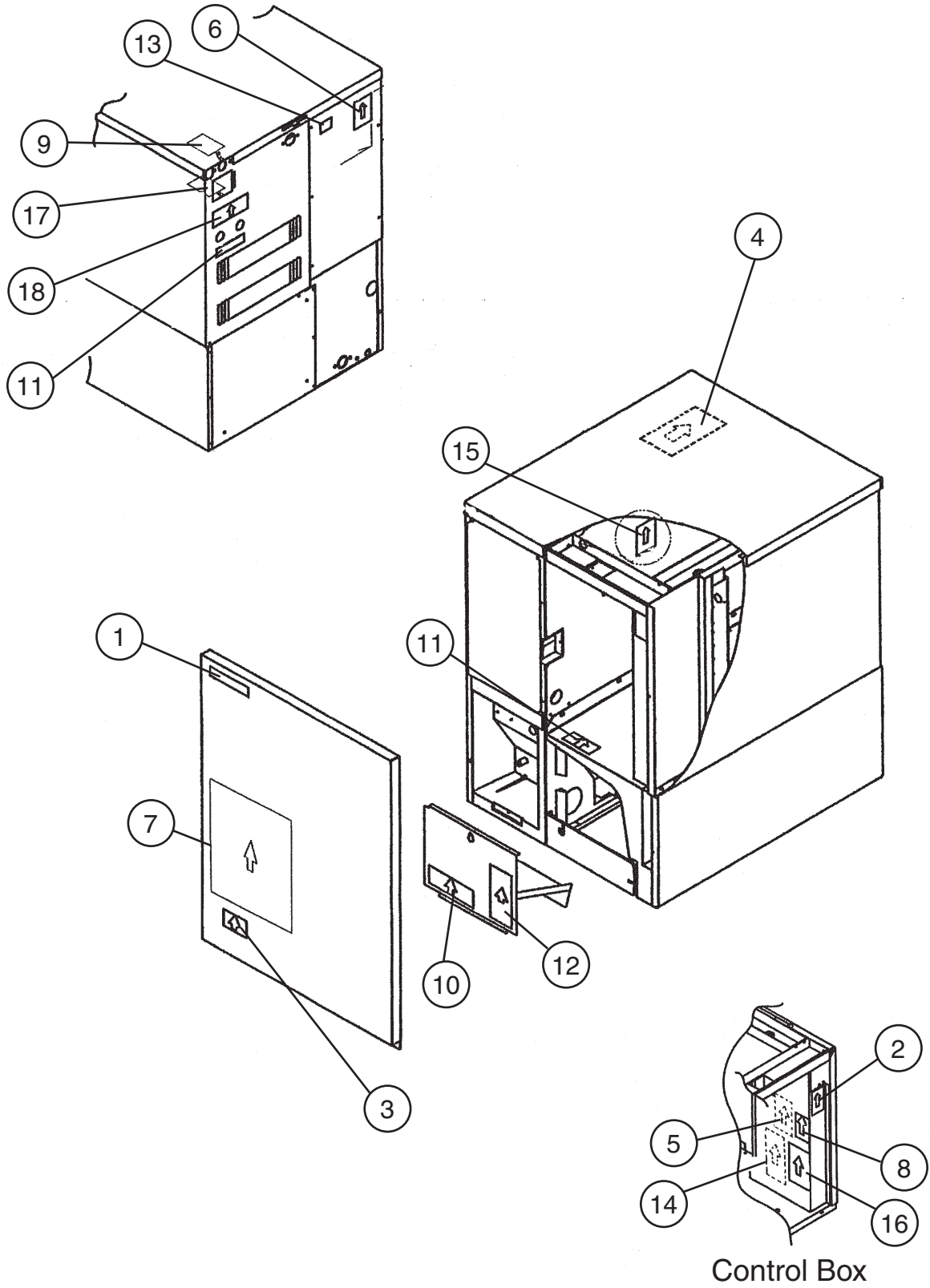

Title: **E. Label Location** Model: **KM-461MRH**

Index No.	Description	Material or Model Number	Part Number	Required Number																
				R-0																
1	Emblem	PETP FILM	4A0560-01	1																
2	Label - Fuse	PETP FILM	4A2817-01	1																
3	Label – Penguin – HA (R)	PETP FILM	4A0526-01	1																
4	Maintenance Label	PVC FILM	326218-01	1																
5	Wiring Label	PVC FILM	3A3889-01	1																
6	Nameplate	PES FILM	2A3771-03	1																
7	Instruction Sheet	PAPER	2A3807-01	1																
8	Manual Label	PVC FILM	446564-01	1																
9	Tag – Warning: Electrical Connection	PAPER	435005-01	1																
10	Operation Label – Valve	PVC FILM	439541-01	1																
11	Label – R404A	PES FILM	4A0960-01	2																
12	Caution Label (H)	PVC FILM	439148-01	1																
13	Instruction Label	PVC FILM	444575-01	1																
14	Label – Control Board	PVC FILM	3A2220-01	1																
15	Rating Label	PES FILM	2A3772-03	1																
16	Label – Alarm	-	4A3517-01	1																
17	Tag – Fan Motor Leads	-	4A1494-01	1																
18	Caution – Remote Label	-	4A1491-01	1																

F. Front Panel Assembly
KM-461MAH, KM-461MWH, KM-461MRH
R-0

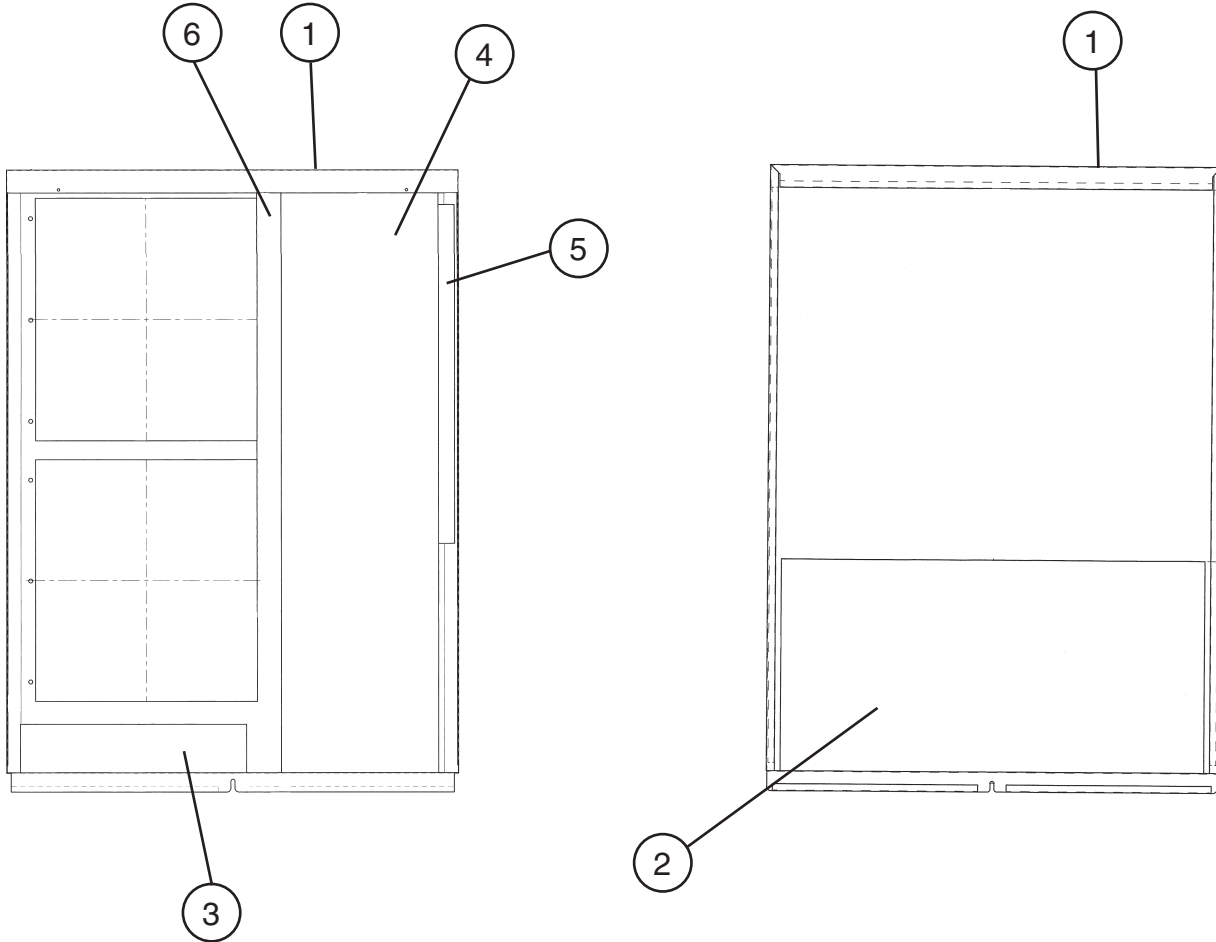

Title: F. Front Panel Assembly Model: KM-461MAH, KM-461MWH, KM-461MRH											
Index No.	Description	Material or Model Number	Part Number	Required Number							
				R-0							
1	Front Panel	KM-461MAH	2A2130-04	1							
		KM-461MWH, KM-461MRH	2A2130-05	1							
2	Insulation (A)	-	4A2507-01	1							
3	Insulation (B)	-	4A1872-01	1							
4	Front Insulation (C)	-	3A3885-01	1							
5	Foam Seal	L = 420	4A1163L01	1							
6	Foam Seal	L = 530	4A1163L01	1							

G. Top Panel Assembly
KM-461MAH, KM-461MWH, KM-461MRH
 R-0

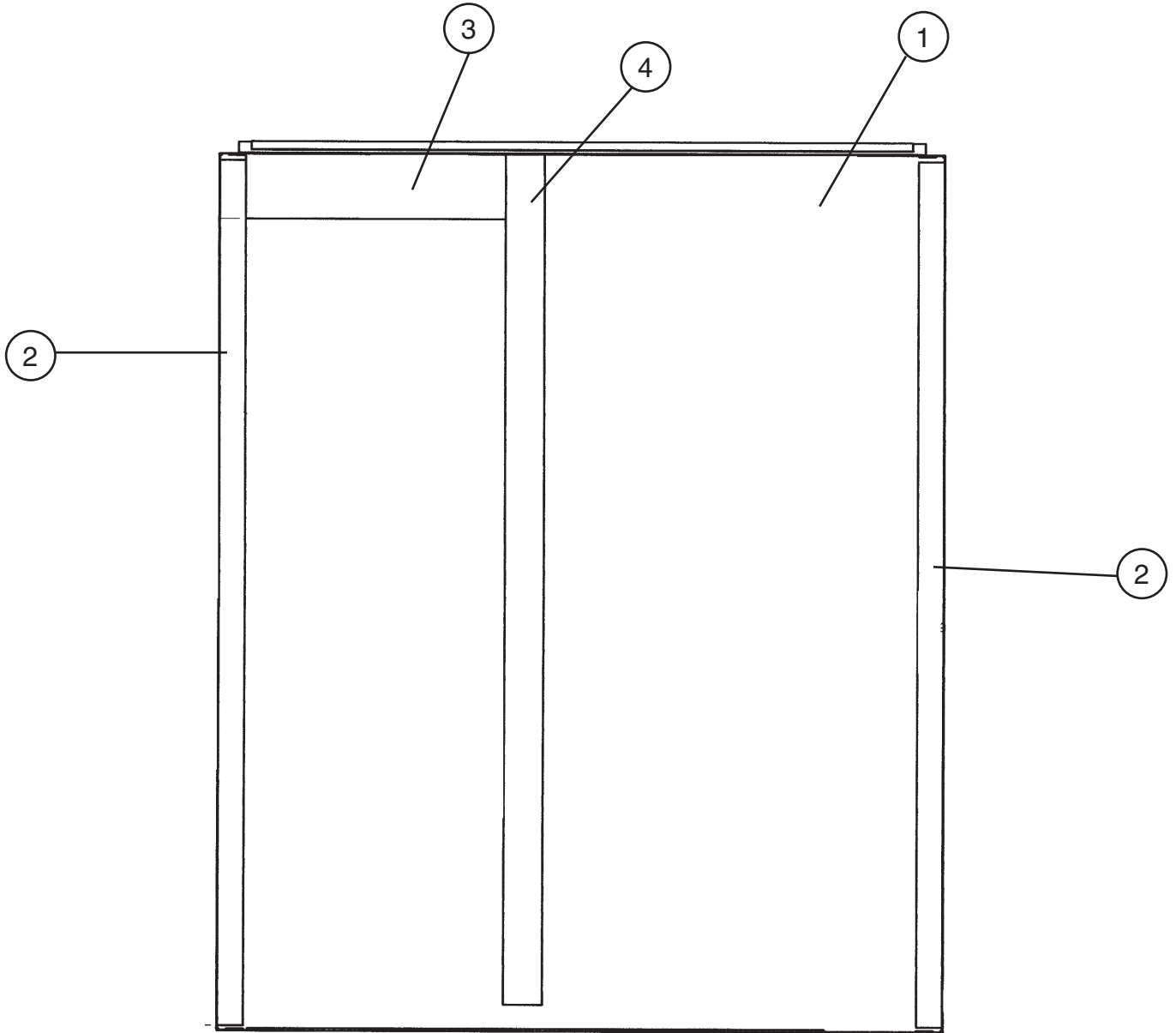

Title: G. Top Panel Assembly Model: KM-461MAH, KM-461MWH, KM-461MRH											
Index No.	Description	Material or Model Number	Part Number	R-0	Required Number						
1	Top Panel	-	2A2133-01	1							
2	Gasket	-	427014-04	2							
3	Insulation	-	438012-01	1							
4	Foam Seal	L = 658	4A1163L01	1							

H. Pump Motor Assembly
KM-461MAH, KM-461MWH, KM-461MRH
R-0

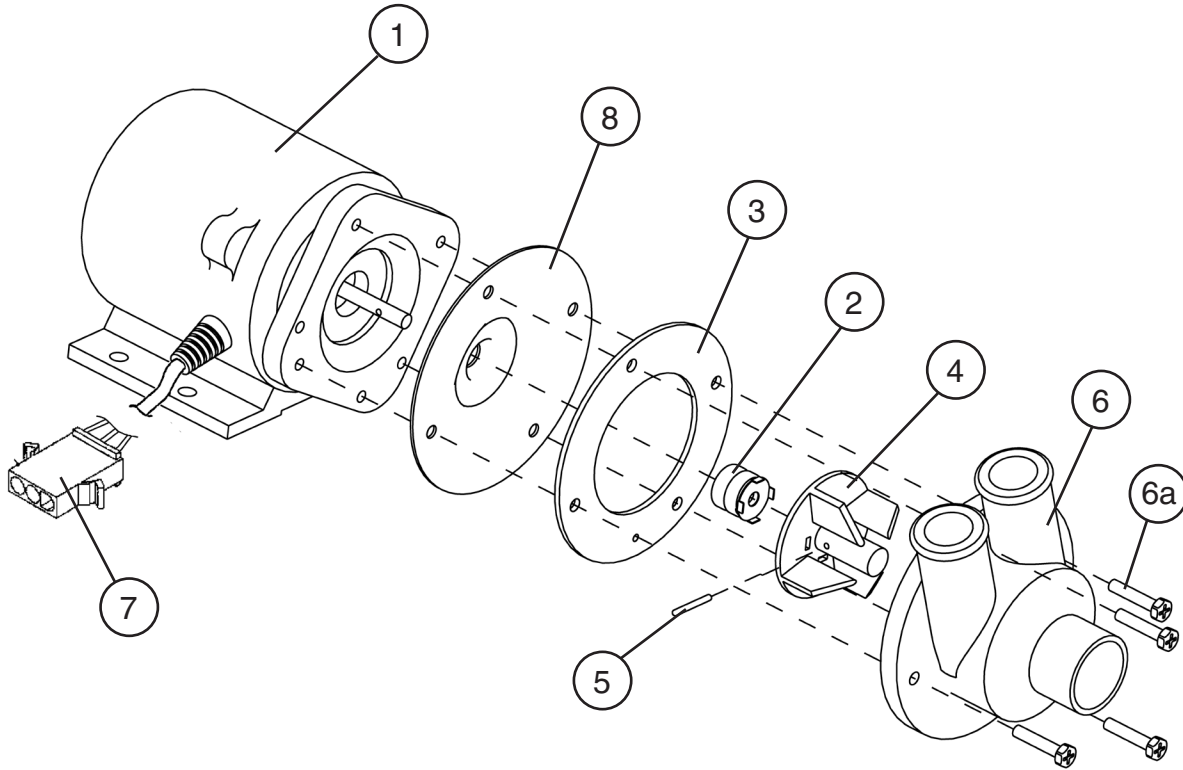

Title: H. Pump Motor Assembly Model: KM-461MAH, KM-461MWH, KM-461MRH										
Index No.	Description	Material or Model Number	Part Number	Required Number						
				R-0						
1	Pump Motor	APTA9210WD1 120V	2A2758-01	1						
2	Mechanical Seal / R	HKU90-J9001	465627-01	1						
3	Pump Gasket	EPDM	4A2974-01	1						
4	Impeller	ABS	433522-01	1						
5	Pin	SS	4A0648-01	1						
6	Pump Housing	ABS	211409-01	1						
6a	Screw	4x20, Geomet 321coated SS	4A3871-01	4						
7	Plug Housing	-	412832-06	1						
8	Pump Flange	-	3A2988-01	1						

J. Control Assembly
KM-461MAH, KM-461MWH, KM-461MRH
 R-0

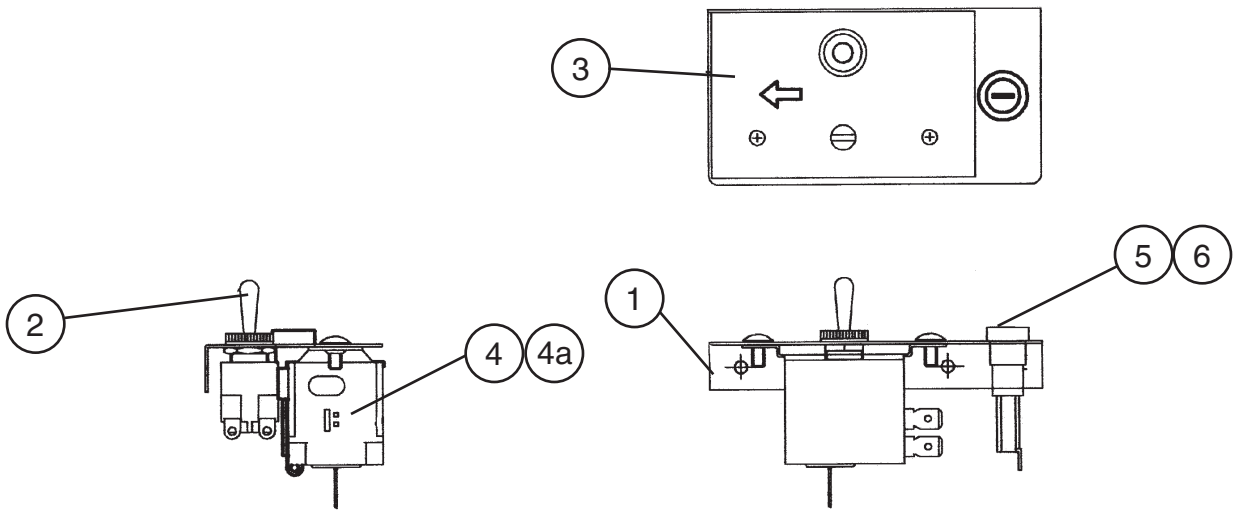

Title: J. Control Assembly Model: KM-461MAH, KM-461MWH, KM-461MRH												
Index No.	Description	Material or Model Number	Part Number	Required Number								
				R-0								
1	Control Box (C)	-	4A2816-01	1								
2	Toggle Switch	8966K84	443119-01	1								
3	Control Label	-	4A2909-01	1								
4	Thermostat	-	4A2879-01	1								
4a	Truss Head Screw	-	7C31-0408	2								
5	Fuse Holder	-	4A0892-01	1								
6	Fuse	AGC10	4A0893-07	1								

K. Accessories

KM-461MAH, KM-461MWH, KM-461MRH

R-0

Title: K. Accessories Model: KM-461MAH, KM-461MWH, KM-461MRH												
Index No.	Description	Material or Model Number	Part Number	R-0	Required Number							
1	Instruction Manual	PAPER	91A1MK10B	1								
2	Universal Brace	GS	4A0363-01	2								
3	Hex Head Bolt	5x12, SS	7B0230512	4								
Packaging			2A3865A01									
1	Tray Assembly - Top	-	1A1222G01	1								
2	Tray Assembly - Bottom	-	1A1223G01	1								
3	Pallet	-	2A3684-01	1								
4	Carton	-	2A3862-29	1								
5	Plastic Support	-	2A3865-09	4								
6	Corner Post	-	3A4040-03	4								
7	Bar Code Label	-	4A2999-01	4								