

ISSUED: FEB. 21, 2001

REVISED: SEPT. 25, 2001



HOSHIZAKI MODULAR CRESCENT CUBER

MODELS

KM-630MAH

KM-630MWH

KM-630MRH

INSTRUCTION MANUAL

— IMPORTANT —

Only qualified service technicians should attempt to install, service or maintain this icemaker. No installation, service or maintenance should be undertaken until the technician has thoroughly read this Instruction Manual. Likewise, the owner/manager should not proceed to operate the icemaker until the installer has instructed them on its proper operation.

HOSHIZAKI provides this manual primarily to assist qualified service technicians in the installation, maintenance and service of the icemaker.

Should the reader have any questions or concerns which have not been satisfactorily addressed, please call or write to the HOSHIZAKI Technical Support Department for assistance.

HOSHIZAKI AMERICA, INC.
618 Highway 74 South
Peachtree City, GA 30269

Attn: HOSHIZAKI Technical Support Department

Phone: 1-800-233-1940 Technical Service
(770) 487-2331
Fax: (770) 487-3360

NOTE: To expedite assistance, all correspondence/communication **MUST** include the following information:

- Model Number
- Serial Number
- Complete and detailed explanation of the problem

- Please review this manual. It should be read carefully before the icemaker is installed and operated. Only qualified service technicians should install, service and maintain the icemaker. This manual should be made available to the technician prior to installation, maintenance or service.
- Keep this manual with the icemaker for future reference.

CONTENTS



PAGE

I.	SPECIFICATIONS	4
1.	NAMEPLATE RATING	4
[a]	KM-630MAH (Air-cooled)	4
[b]	KM-630MWH (Water-cooled)	5
[c]	KM-630MRH (Remote Air-cooled)	6
2.	DIMENSIONS/CONNECTIONS	7
[a]	KM-630MAH	7
[b]	KM-630MWH	8
[c]	KM-630MRH	9
II.	INSTALLATION AND OPERATING INSTRUCTIONS	10
1.	CHECKS BEFORE INSTALLATION	10
2.	HOW TO REMOVE PANELS	11
3.	LOCATION	11
4.	SET UP	12
5.	ELECTRICAL CONNECTION	12
6.	INSTALLATION OF REMOTE CONDENSER UNIT	13
[a]	CHECKS BEFORE INSTALLATION	13
[b]	LOCATION	13
[c]	SET UP	14
[d]	ELECTRICAL CONNECTION	15
[e]	STACKING CONDENSER UNIT	16
7.	WATER SUPPLY AND DRAIN CONNECTIONS	17
8.	FINAL CHECK LIST	19
9.	START UP	20
10.	PREPARING THE ICEMAKER FOR LONG STORAGE	22
III.	CLEANING AND MAINTENANCE INSTRUCTIONS	24
1.	CLEANING INSTRUCTIONS	24
[a]	CLEANING PROCEDURE	24
[b]	SANITIZING PROCEDURE	26
2.	MAINTENANCE	27

I. SPECIFICATIONS

1. NAMEPLATE RATING

[a] KM-630MAH (Air-cooled)

HOSHIZAKI ICE MAKER	
MODEL NUMBER	KM-630MAH
SERIAL NUMBER	
AC SUPPLY VOLTAGE	208-230/60/1 (3 WIRE WITH NEUTRAL FOR 115V)
COMPRESSOR	208-230V 6.0RLA 37LRA
PUMP	120V 0.5LRA 10W
FAN	120V 1FLA 30W
OTHER	115-120V 0.15A
MAXIMUM FUSE SIZE	15 AMPS
MAX. HACR BREAKER (USA ONLY)	15 AMPS
MAX. CIRC. BREAKER (CANADA ONLY)	15 AMPS
MINIMUM CIRCUIT AMPACITY	15 AMPS
DESIGN PRESSURE	HI-467PSI LO-230PSI
REFRIGERANT	404A 1 LB. 7.6 OZ.
MOTOR-COMPRESSOR THERMALLY PROTECTED	
NOT INTENDED FOR OUTDOOR USE	
HOSHIZAKI AMERICA, INC. Peachtree City, GA	
 LISTED ICE MAKER WITHOUT STORAGE MEANS 946Z	  
	COMPONENT 

See the Nameplate for electrical and refrigeration specifications. This Nameplate is located on the upper right hand side of rear panel.

Since this Nameplate is located on the rear panel of the icemaker, it cannot be read when the back of the icemaker is against a wall or against another piece of kitchen equipment. Therefore, the necessary electrical and refrigeration information is also on the rating label, which can be easily seen by removing only the front panel of the icemaker.

We reserve the right to make changes in specifications and design without prior notice.

[b] KM-630MWH (Water-cooled)





HOSHIZAKI ICE MAKER	
MODEL NUMBER	KM-630MWH
SERIAL NUMBER	
AC SUPPLY VOLTAGE	208-230/60/1 (3 WIRE WITH NEUTRAL FOR 115V)
COMPRESSOR	208-230V 6.0RLA 37LRA
PUMP	120V 0.5FLA 10W
FAN	--- --- ---
OTHER	115-120V 0.15A
MAXIMUM FUSE SIZE	15 AMPS
MAX. HACR BREAKER (USA ONLY)	15 AMPS
MAX. CIRC. BREAKER (CANADA ONLY)	15 AMPS
MINIMUM CIRCUIT AMPACITY	15 AMPS
DESIGN PRESSURE	HI-427PSI LO-230PSI
REFRIGERANT	404A 1LB. 2.5 OZ.
MOTOR-COMPRESSOR THERMALLY PROTECTED	
NOT INTENDED FOR OUTDOOR USE	
HOSHIZAKI AMERICA, INC.	
Peachtree City, GA	
 LISTED ICE MAKER WITHOUT STORAGE MEANS 946Z   	
COMPONENT 	

See the Nameplate for electrical and refrigeration specifications. This Nameplate is located on the upper right hand side of rear panel.

Since this Nameplate is located on the rear panel of the icemaker, it cannot be read when the back of the icemaker is against a wall or against another piece of kitchen equipment. Therefore, the necessary electrical and refrigeration information is also on the rating label, which can be easily seen by removing only the front panel of the icemaker.

We reserve the right to make changes in specifications and design without prior notice.

[c] KM-630MRH (Remote Air-cooled)

HOSHIZAKI ICE MAKER			
MODEL NUMBER	KM-630MRH		
SERIAL NUMBER			
AC SUPPLY VOLTAGE	208-230/60/1 (3 WIRE WITH NEUTRAL FOR 115V)		
COMPRESSOR	208-230V 6.0RLA 37LRA		
PUMP	120V	0.5FLA	10W
FAN	REMOTE120V	3A	MAX
OTHER	115-120V	0.3A	
MAXIMUM FUSE SIZE	15 AMPS		
MAX. HACR BREAKER (USA ONLY)	15 AMPS		
MAX. CIRC. BREAKER (CANADA ONLY)	15 AMPS		
MINIMUM CIRCUIT AMPACITY	15 AMPS		
DESIGN PRESSURE	HI-467PSI LO-230PSI		
REFRIGERANT	404A		
MOTOR-COMPRESSOR THERMALLY PROTECTED			
NOT INTENDED FOR OUTDOOR USE			
HOSHIZAKI AMERICA, INC.			
Peachtree City, GA			
 LISTED ICE MAKER WITHOUT STORAGE MEANS 946Z			
  			
			

See the Nameplate for electrical and refrigeration specifications. This Nameplate is located on the upper right hand side of rear panel.

Since this Nameplate is located on the rear panel of the icemaker, it cannot be read when the back of the icemaker is against a wall or against another piece of kitchen equipment. Therefore, the necessary electrical and refrigeration information is also on the rating label, which can be easily seen by removing only the front panel of the icemaker.

We reserve the right to make changes in specifications and design without prior notice.

2. DIMENSIONS/CONNECTIONS

Unit: mm. (inches)

[a] KM-630MAH

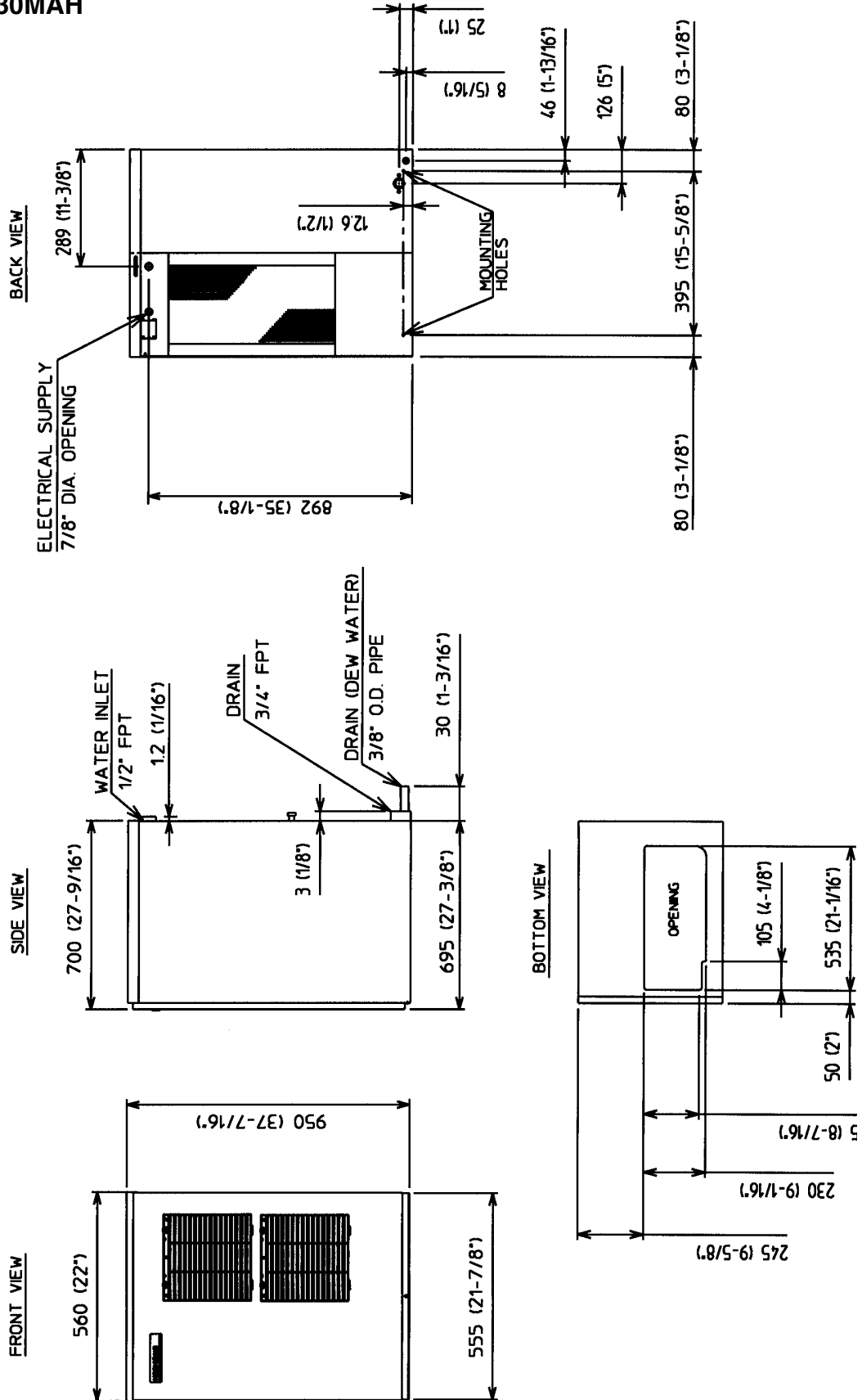

Unit: mm. (inches)

[b] KM-630MWH

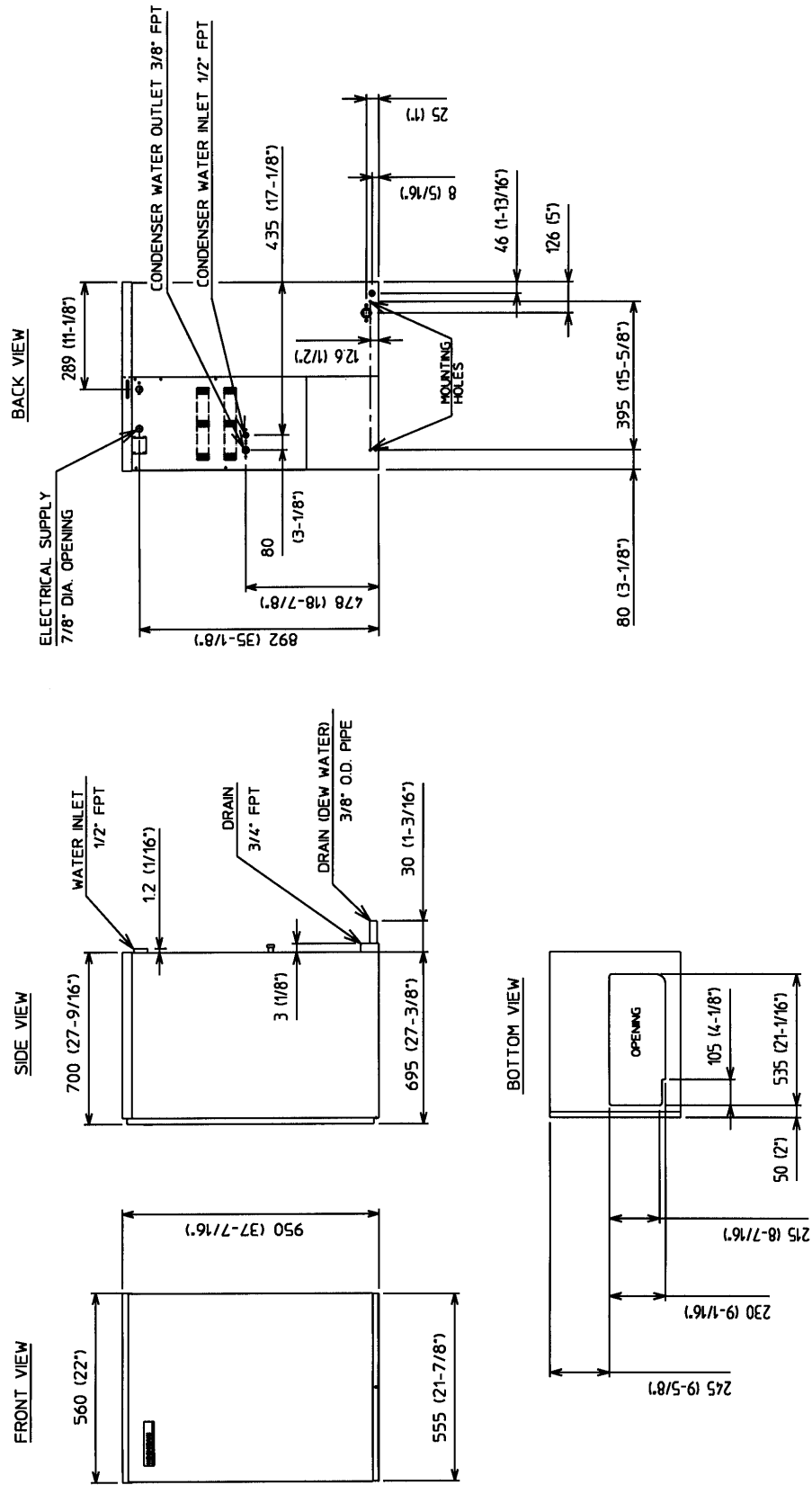

[c] KM-630MRH

Unit: mm. (inches)

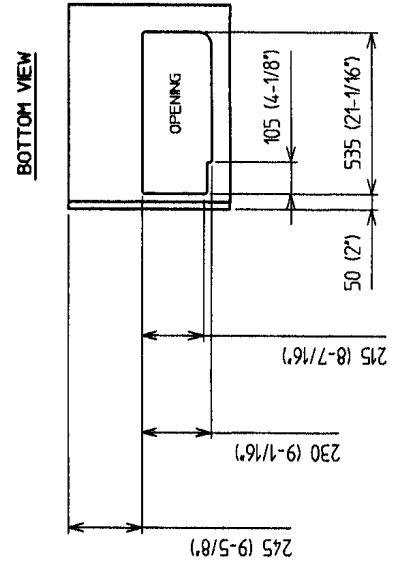
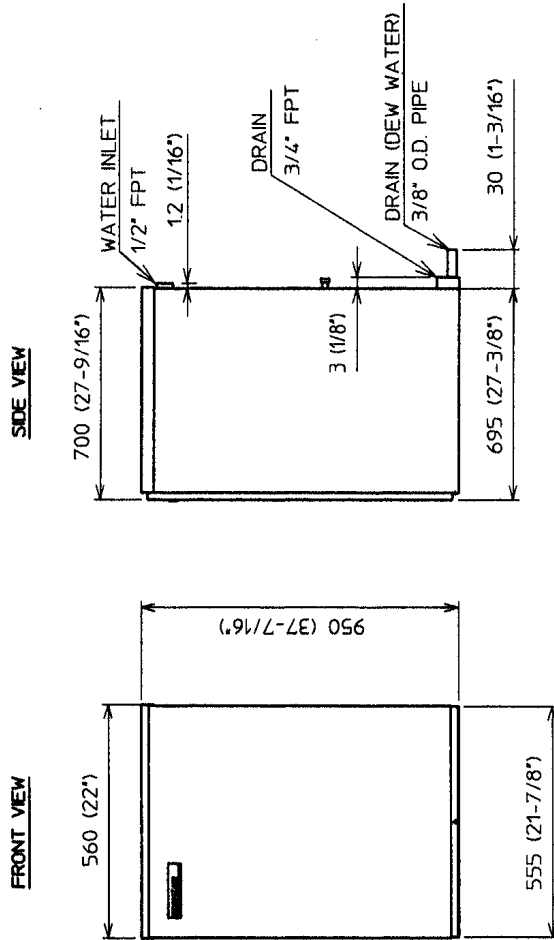
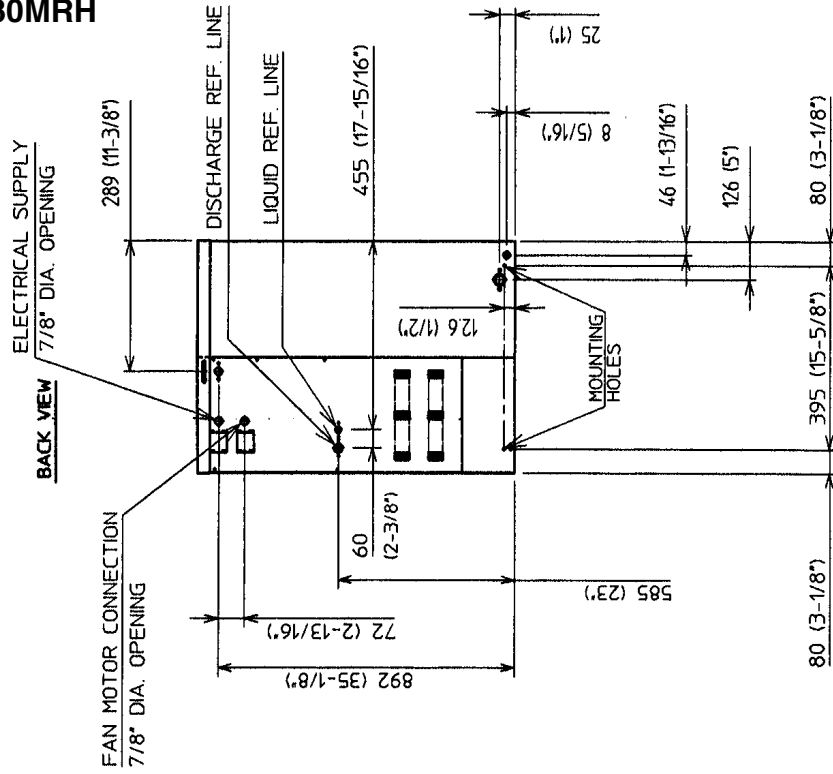

II. INSTALLATION AND OPERATING INSTRUCTIONS

1. CHECKS BEFORE INSTALLATION

IMPORTANT

Remove shipping carton, tape(s) and packing. If packing material is left in the icemaker, it will not work properly.

- 1) Remove the panels to prevent damage when installing the icemaker. See “2. HOW TO REMOVE PANELS.”
- 2) Remove the package containing the accessories.
- 3) Release the Bin Switch assembly:
 - a) Remove the Base Cover to access the Bin Switch assembly.
 - b) Remove the Bin Control Shield by loosening the thumbscrew.
 - c) Remove the shipping tape holding the switch actuator arm and paddle in place so that the paddle swings down freely.
 - d) Replace the Shield, secure the thumbscrew and replace the Base Cover.
- 4) Remove the protective plastic film from the panels. If the icemaker is exposed to the sun or to heat, remove the film after the icemaker cools.
- 5) Check that the refrigerant lines do not rub or touch lines or other surfaces, and that the fan blade turns freely.
- 6) Check that the Compressor is snug on all mounting pads.
- 7) See the Nameplate on the Rear Panel, and check that your voltage supplied corresponds with the voltage specified on the Nameplate.
- 8) This icemaker needs a storage bin. The recommended storage bin is HOSHIZAKI ICE STORAGE BIN, Model B-300 series.
- 9) On remote air-cooled models, a remote condenser unit is needed. The recommended remote condenser unit is HOSHIZAKI CONDENSER UNIT, MODEL URC-6F.

2. HOW TO REMOVE PANELS - See Fig. 1

- a) Front Panel Remove the screw.
Lift up and pull toward you.
- b) Top Panel Lift up slightly its front, push away,
and then lift off.
- c) Side Panel (R) Remove the screw.
Pull slightly toward you, and lift off.
- d) Insulation Panel ... Lift up slightly, and pull toward you.
- e) Base Cover Lift up slightly, and pull toward you.

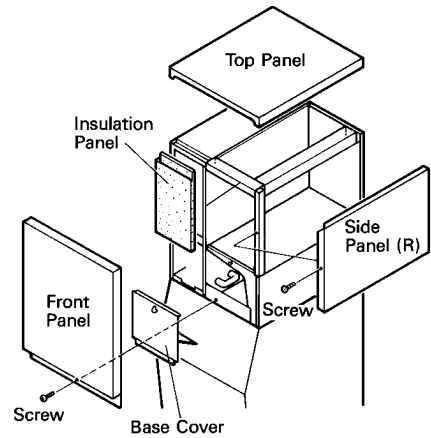

Fig. 1

3. LOCATION

WARNING

This icemaker is not intended for outdoor use. Normal operating ambient temperature should be within +45°F to +100°F; Normal operating water temperature should be within +45°F to +90°F. Operation of the icemaker, for extended periods, outside of these normal temperature ranges may affect production capacity.

For best operating results:

- Icemaker should not be located next to ovens, grills or other high heat producing equipment.
- Location should provide a firm and level foundation for the equipment.
- Allow 6" clearance at rear, sides and top for proper air circulation and ease of maintenance and/or service should they be required.

4. SET UP

- 1) Unpack the Storage Bin, and attach the four adjustable legs provided (bin accessory) to the bottom of the Storage Bin.
- 2) Position the Storage Bin in the selected permanent position.
- 3) Place the icemaker on the top of the Storage Bin.
- 4) Secure the icemaker to the Storage Bin, by using the two mounting bracket and the four bolts provided. See Fig. 2
- 5) Level the icemaker/Storage Bin in both the left-to-right and front-to-rear directions. Adjust the Ice Bin Legs to make the icemaker level.
- 6) Replace the panels in their correct positions.

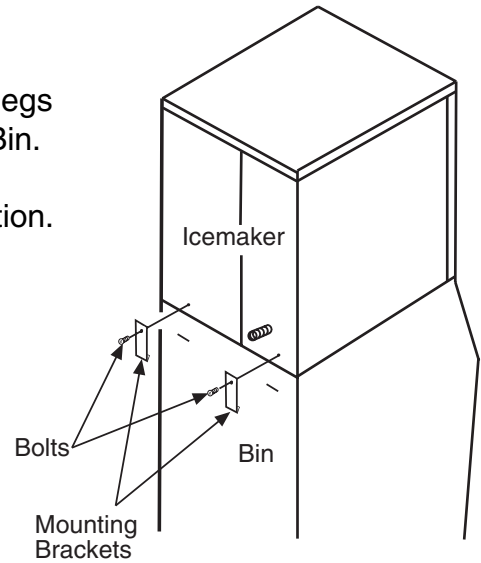

Fig. 2

5. ELECTRICAL CONNECTION

WARNING

1. Electrical connection must be made in accordance with the instructions on a "WARNING" tag, provided with the pigtail leads in the Junction Box.
2. This icemaker requires a ground that meets the national and local electrical code requirements. To prevent possible electrical shock to individuals or extensive damage to the equipment, install a proper ground wire to the icemaker.

- The white lead must be connected to the neutral conductor of the power source. Miswiring results in severe damage to the icemaker. See Fig. 3.
- This icemaker must have a separate power supply or receptacle of proper capacity. See the Nameplate.
- The opening for the power supply connection is 7/8" diameter to fit a 1/2" trade size conduit.
- Usually an electrical permit and services of a licensed electrician are required.

WARNING

ELECTRICAL CONNECTION

The white lead must be connected to the neutral conductor of the power source. Miswiring results in severe damage to the icemaker. (See Fig. below.)

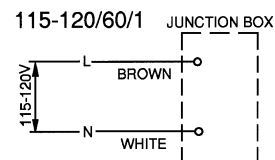

Fig. 3

6. INSTALLATION OF REMOTE CONDENSER UNIT

[a] CHECKS BEFORE INSTALLATION

- 1) Unpack and remove shipping carton, tape(s) and packing.
- 2) Check that the refrigerant lines do not rub or touch lines or other surfaces, and that the fan blade moves freely.

[b] LOCATION

The condenser unit must be positioned in a permanent site under the following guidelines.

- A firm and flat site.
- A dry and well ventilated area with 24" (610 mm) clearance on both front and rear for ease of maintenance and service should they be required.
- Normal condenser ambient temperature: -20°F (-29°C) to +122°F (50°C). Temperatures not within this operating range may affect the production capacity of the icemaker.
- The maximum line length for the standard refrigerant charge is 66 feet (20.1 m). Should an installation require a longer line length, please call 1-800-233-1940 for recommendations concerning the correct additional refrigerant charge to be added.

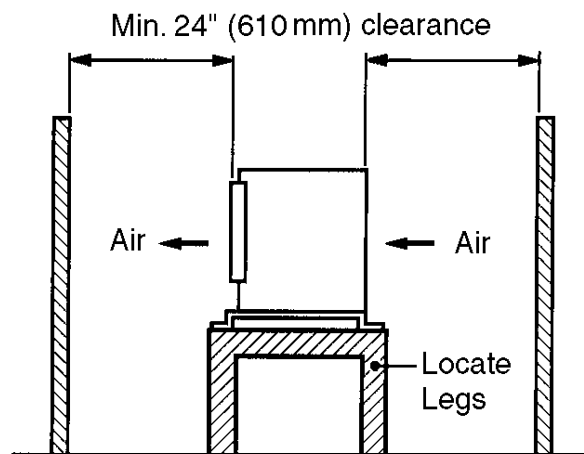

Fig. 4

Note: If the recommended guidelines of the installation are exceeded, the icemaker performance may be reduced.

[c] SET UP

- 1) Secure the Legs to the condenser unit with eight M8 x 16 mm Hexagon Bolts and M8 Nuts as shown in the illustration. See Fig. 5.

Note: Locate the Legs symmetrically.

- 2) The Legs have eight mounting holes. Secure the Legs with eight bolts (not included).
- 3) Install enough length of two copper tubings provided with Aeroquip couplings between the icemaker and the condenser unit. The two copper tubings should be insulated separately. See Fig. 7.

- Precharged tubing kits, available as optional equipment from HOSHIZAKI AMERICA, are recommended.

- 4) Line sets fabricated in the field should be evacuated through the charging ports on the Aeroquip couplings and charged with R-404A refrigerant vapor to a pressure of 15 - 30 PSIG.

Note: Factory fabricated tubing kits are precharged and do not need to be evacuated.

- 5) Remove the plastic caps protecting the couplings. Attach the two refrigerant lines to the male couplings on the icemaker and the remote condenser unit. Each refrigerant line must be connected as follows:

Icemaker discharge refrigerant line - 3/8" (9.52 mm) OD tubing to "DIS" of condenser unit
Icemaker liquid refrigerant line - 1/4" (6.35 mm) OD tubing to "LIQ" of condenser unit

Note: Care should be taken that the unit, line set and Condenser contain the same type refrigerant prior to making connections. Mixing of refrigerants will result in improper operation and possible damage to the refrigeration system. Make the connections at the remote condenser first and then at the icemaker.

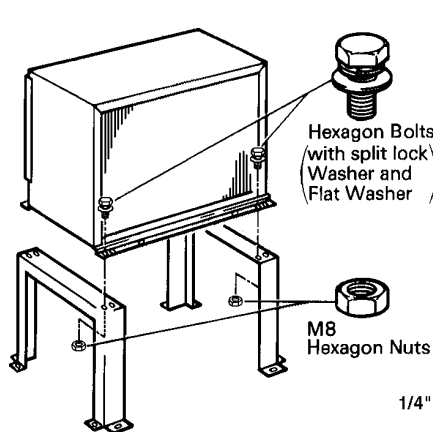

Fig. 5

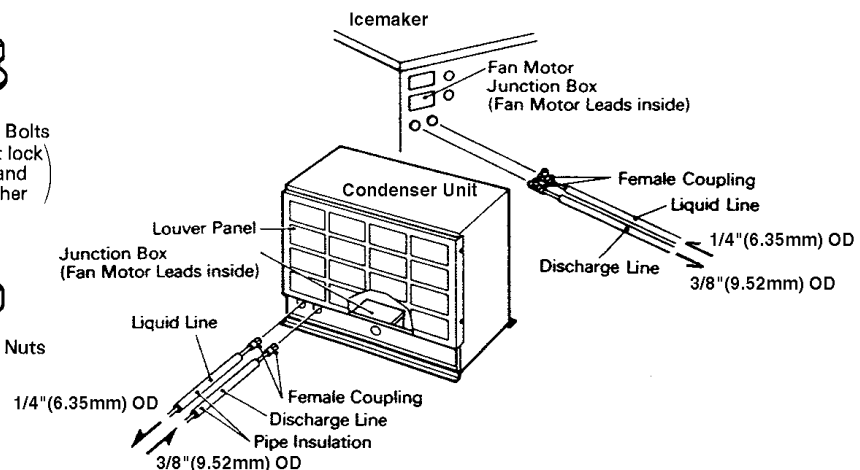

Fig. 6

[d] ELECTRICAL CONNECTION

WARNING

This remote condenser unit requires a ground that meets the national and local electrical code requirements. To prevent possible electrical shock to individuals or extensive damage to equipment, install a proper ground wire to this condenser unit.

- This condenser unit must be connected to the Fan Motor Junction Box on the icemaker.
 - The opening for the power supply connection is 7/8" (22.2 mm) DIA to fit a 1/2" (12.7 mm) trade size conduit.
 - Usually an electrical permit and services of a licensed electrician are required.
- 1) Remove the Panel.
 - 2) Remove the Junction Box Cover.
 - 3) Connect the Fan Motor leads in the Junction Box of the remote condenser unit to the Fan Motor leads in the Junction Box of the HOSHIZAKI remote air-cooled icemaker.
 - 4) Install a ground wire to the remote condenser unit.
 - 5) Replace the Junction Box Cover and the Panel in their correct position.

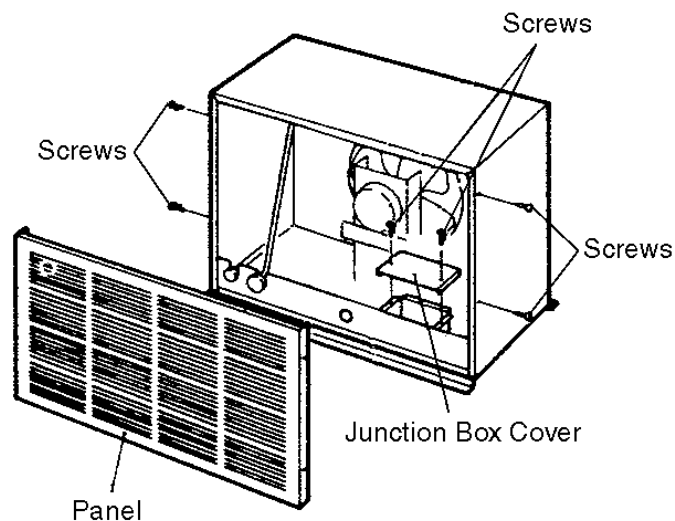

Fig. 7

[e] STACKING CONDENSER UNIT

- 1) Secure the lower condenser unit to the Legs with eight bolts (not included).
- 2) Attach the upper condenser unit on the top of the lower.
- 3) Secure the upper condenser unit with the four screws provided.
- 4) Install refrigerant lines, and make electrical connection for each Fan Motor as shown in Items [c] and [d].

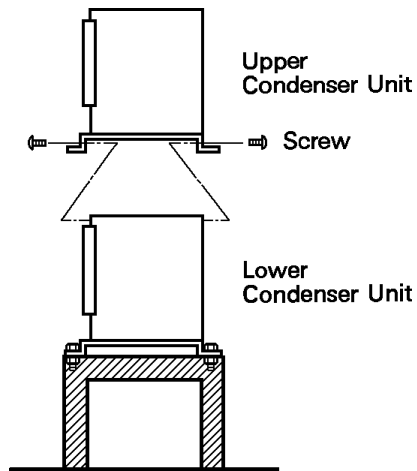

Fig. 8

7. WATER SUPPLY AND DRAIN CONNECTIONS - See Fig. 9

WARNING

To prevent damage to the pump assembly, do not operate the icemaker when the water supply is OFF, or if the pressure is below 10 PSIG (0.7 Bar). Do not run the icemaker until the proper water pressure is reached.

- Water supply inlet is 1/2" (12.7 mm) female pipe thread (FPT).

Note: On water-cooled model, two water supply inlets are provided. One is for the icemaker, and the other is for the water-cooled condenser.

- A water supply line shut-off valve and drain valve should be installed. A minimum of 3/8" (9.52 mm) OD copper tubing is recommended for the water supply lines.
- Water supply pressure should be a minimum of 10 PSIG (0.7 Bar) and a maximum of 113 PSIG (7.9 Bar). If the pressure exceeds 113 PSIG (7.9 Bar), the use of a pressure reducing valve is required.
- Drain outlet for icemaker dump is 3/4" (19.05 mm) FPT. The drain for condensation is a 3/8" (9.52 mm) ID pipe. The icemaker drain and the condenser drain piping connections must be made separately from the bin drain.

Note: On water-cooled model, a 3/8" (9.5 mm) FPT is provided for the condenser drain outlet.

- The drains must have 1/4" fall per foot (20.9 mm fall per meter) on horizontal runs to get a good flow.
- The drains should not be piped directly to the sewer system. An air gap of a minimum of 2 vertical inches should be between the end of the drain pipe from the icemaker or the ice bin and the floor drain.
- This icemaker should be installed in accordance with applicable national, state and local regulations.
- A plumbing permit and services of a licensed plumber may be required in some areas.
- In some areas, a back flow preventer may be required in the cooling water circuit.

**KM-630MAH
KM-630MRH**

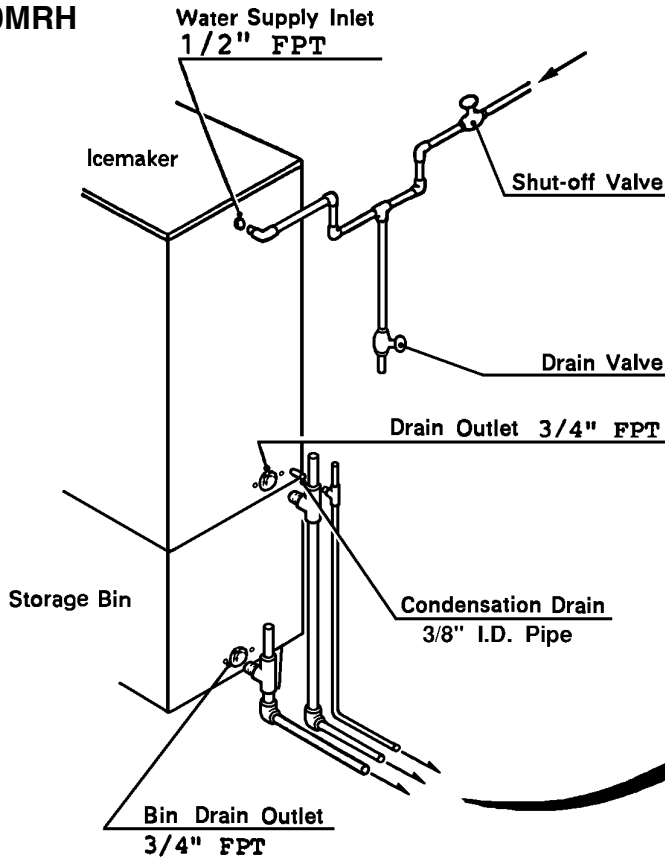

Separate piping to approved drain. Leave a two inch (5 cm.) vertical air gap between the end of each pipe and the drain.

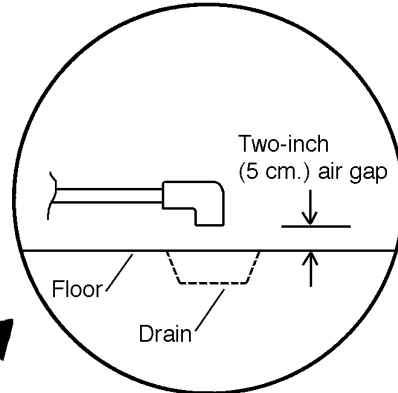

KM-630MWH

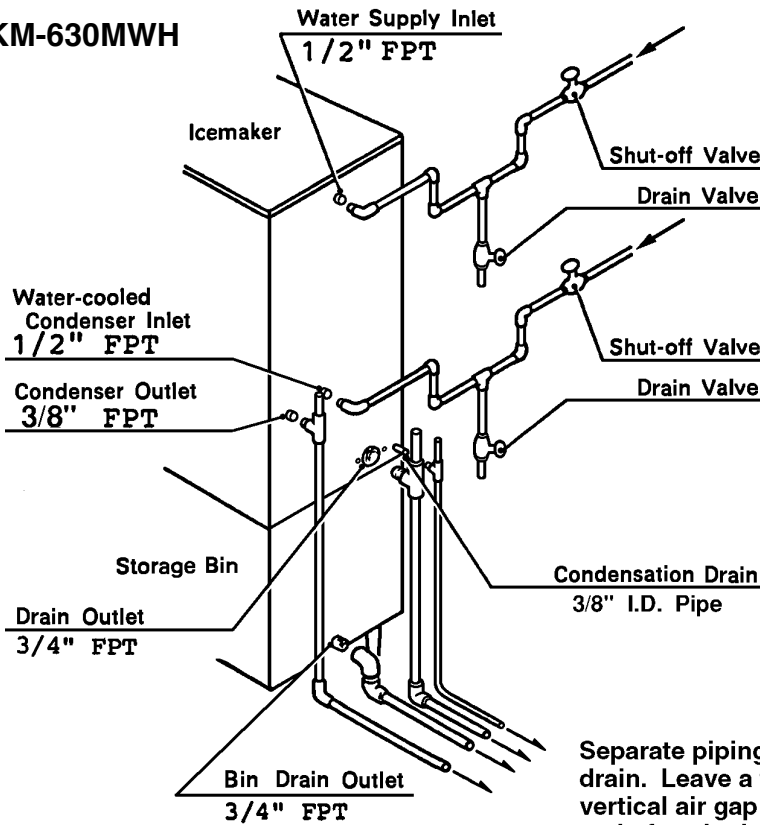

Separate piping to approved drain. Leave a two inch (5 cm.) vertical air gap between the end of each pipe and the drain.

Fig. 9

8. FINAL CHECK LIST

- 1) Is the icemaker level?
- 2) Is the icemaker in a site where the ambient temperature is within +45°F (7°C) to +100°F (38°C) all year around?
- 3) Is there at least 6" (152 mm) clearance around the icemaker for maintenance or service?
- 4) Have all shipping carton, tapes and packing been removed from the icemaker?
 - a) Is the cube guide in its correct position?
 - b) Does the Bin Switch assembly actuator arm and paddle swing freely?
- 5) Have all electrical and piping connections been made?
- 6) Has the power supply voltage been checked or tested against the nameplate rating? And has a proper ground been installed in the icemaker?
- 7) Are the Water Supply Line Shut-off Valve and Drain Valve installed? Has the water supply pressure been checked to ensure a minimum of 10 PSIG (0.7 Bar) and a maximum of 113 PSIG (7.9 Bar)?

Note: The icemaker may stop running when the water supply is OFF, or if the pressure is below 10 PSIG (0.7 Bar). When the proper water pressure is reached, the icemaker automatically starts running again.
- 8) Have the compressor hold-down bolts and refrigerant lines been checked against vibration and possible failure?
- 9) Has the end user been given the instruction manual, and instructed on how to operate the icemaker and the importance of the recommended periodic maintenance?
- 10) Has the end user been given the name and telephone number of an authorized service agent?
- 11) Has the warranty tag been filled out and forwarded to the factory for warranty registration?

9. START UP

CAUTION

1. All parts are factory-adjusted. Improper adjustments may result in failure.
2. If the unit is turned off, wait for at least 3 minutes before restarting the icemaker to prevent damage to the Compressor.
3. Do not operate the unit in the “WASH” position without water in the Water Tank. This will cause damage to the Water Pump seal.

- 1) Open the Water Supply Line Shut-off Valve.
- 2) Remove the Front Panel.
- 3) Move the Control Switch, on the Control Box, to the “ICE” position.
- 4) Replace the Front Panel in its correct position.
- 5) Turn on the power supply, and allow the Water Tank to fill with water and the icemaker to operate for a total of 10 minutes.
- 6) Remove the Front Panel and the Base Cover and turn the control switch to “OFF”.
- 7) Check to assure that the Bin Switch shuts the unit down.
 - a) Turn the control switch to “ICE”.
 - b) Allow the unit to cycle into the freeze mode. This occurs when the pump motor starts to supply water upwards, through the supply tube. After 1-2 minutes in freeze, move the bin switch paddle fully to the right. See Fig. 10.
 - c) The unit should shut down within 3-5 seconds.

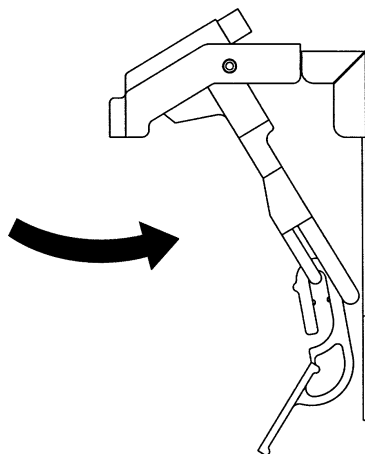

Fig. 10

Note: The Bin Switch will only shut down the unit at the end of a harvest or within the first 5 minutes of the freeze cycle. To shut the unit down outside of this time period turn the control switch to “OFF”.

8) Turn off the power supply. Remove one end of the Pump Tubing, and drain the Water Tank. See Fig. 11.

9) Replace the Pump Tubing in its correct position.

10) Clean the Storage Bin.

11) Replace the Base Cover and the Front Panel in their correct positions.

12) Turn on the power supply, and start the automatic icemaking process.

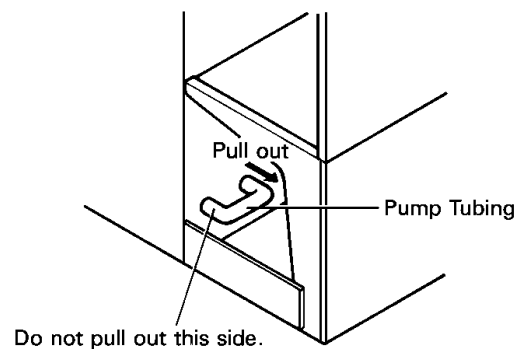

Fig. 11

10 . PREPARING THE ICEMAKER FOR LONG STORAGE

WARNING

When shutting off the icemaker for an extended time, drain out all water from the water line and remove the ice from the Storage Bin. The Storage Bin should be cleaned and dried. Drain the icemaker to prevent damage to the water supply line at sub-freezing temperatures, using a foot or hand pump. Shut off the icemaker until the proper ambient temperature is resumed.

- When the icemaker is not used for two or three days, it is sufficient to only move the Control Switch to the "OFF" position, unless the icemaker will be at sub-freezing temperatures.

[1] On water-cooled model only, first remove the water from the water-cooled condenser:

- 1) Remove the Front Panel.
- 2) Move the Control Switch, on the Control Box, to the "OFF" position.
- 3) Wait 3 minutes.
- 4) Move the Control Switch to the "ICE" position.
- 5) Allow 5 minutes for the icemaker to fill with water and the Water Pump to start operating.
- 6) Close the Water-cooled Condenser Water Supply Line Shut-off Valve. See Fig. 9.
- 7) Open the Drain Valve for the water-cooled condenser water supply line.
- 8) Allow the line to drain by gravity.
- 9) Attach compressed air or carbon dioxide supply to the Condenser Water Line Drain Valve.
- 10) Blow the water-cooled condenser out using compressed air or carbon dioxide until water stops coming out.

[2] Remove the water from the potable water supply line:

- 1) Remove the Front Panel. (Except water-cooled model)
- 2) Move the Control Switch, on the Control Box, to the "OFF" position.
- 3) Wait 3 minutes.

- 4) Close the Potable Water Supply Line Shut-off Valve and open the Potable Water Supply Line Drain Valve. See Fig. 9.
- 5) Allow the line to drain by gravity.
- 6) Attach compressed air or carbon dioxide supply to the Potable Water Line Drain Valve.
- 7) Move the Control Switch to the "ICE" position.
- 8) Blow the potable water line out using compressed air or carbon dioxide.

[3] Drain the Potable Water Tank:

- 1) Turn off the power supply.
- 2) Move the Control Switch, on the Control Box, to the "OFF" position.
- 3) Remove the Base Cover.
- 4) Remove one end of the Pump Tubing, and drain the Water Tank.
- 5) Replace the Pump Tubing and the Base Cover in their correct position.
- 6) Remove all ice from the Storage Bin, and clean the Storage Bin.
- 7) Replace the Front Panel in its correct position.

III. CLEANING AND MAINTENANCE INSTRUCTIONS

1. CLEANING INSTRUCTIONS

WARNING

1. HOSHIZAKI recommends cleaning this unit at least once a year. More frequent cleaning, however, may be required in some existing water conditions.
2. To prevent injury to individuals and damage to the icemaker, do not use ammonia type cleaners.
3. Always wear liquid-proof gloves for safe handling of the cleaning and sanitizing solution. This will prevent irritation in case the solution contacts with skin.

IMPORTANT

1. The Cleaning Valve is used to provide access to the inside of the Evaporator during the cleaning and sanitizing operation. It should be closed for all icemaking operation. The Compressor will not operate unless this valve is completely closed.
2. To open the Cleaning Valve, the Valve Handle should be parallel to the valve body. To close the valve, the Valve Handle should be at a right angle to the valve body.

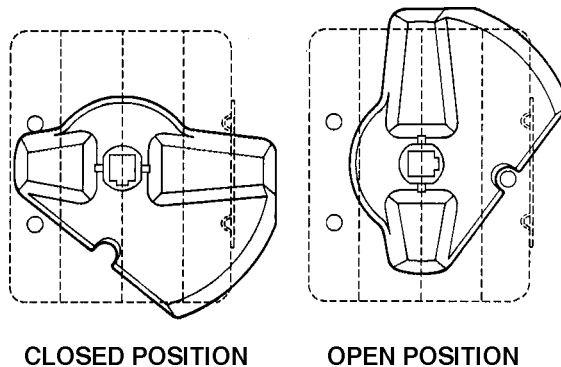

[a] CLEANING PROCEDURE

- 1) Dilute approximately 16 fl. oz. (0.47 l) of recommended cleaner Hoshizaki "Scale Away" or "LIME-A-WAY," (Economics Laboratory, Inc.) with 3 gal. (11.36 l) of water.
- 2) Remove all ice from the Evaporator and the Storage Bin.

Note: To remove cubes on the Evaporator, turn off the power supply and turn it on after 3 minutes. The defrost cycle starts and the cubes will be removed from the Evaporator.

- 3) Turn off the power supply.
- 4) Remove the Front Panel and the Base Cover, and then remove the Insulation Panel by lifting up the panel slightly and pulling it toward you.
- 5) Remove one end of the Pump Tubing. Drain the Water Tank. Replace the Pump Tubing in its correct position. See Fig. 11.
- 6) Pour the cleaning solution into the Water Tank.
- 7) Fully open the Cleaning Valve on the left side wall of the machine compartment.
- 8) Move the Control Switch, on the Control Box, to the "WASH" position
- 9) Replace the Insulation Panel and the Front Panel in their correct position.
- 10) Turn on the power supply, and start the washing process.
- 11) Turn off the power supply after 30 minutes.
- 12) Remove the Front Panel.
- 13) Remove one end of the Pump Tubing. Drain the Water Tank. Replace the Pump Tubing in its correct position.
- 14) Move the Control Switch to the "ICE" position.
- 15) Close the Cleaning Valve.
- 16) Replace the Front Panel in its correct position.
- 17) Turn on the power supply to fill the Water Tank with water.
- 18) Turn off the power supply after 3 minutes.
- 19) Remove the Front Panel, and fully open the Cleaning Valve.
- 20) Move the Control Switch to the "WASH" position.
- 21) Replace the Front Panel in its correct position.
- 22) Turn on the power supply to rinse off the cleaning solution.
- 23) Turn off the power supply after 5 minutes.

24) Remove the Front Panel.

25) Remove one end of the Pump Tubing. Drain the Water Tank. Replace the Pump Tubing in its correct position.

26) Repeat the above steps 14) through 25) three more times to rinse thoroughly.

Note: If you do not sanitize the icemaker, go to the step 10) in “[b] SANITIZING PROCEDURE.”

[b] SANITIZING PROCEDURE - Following Cleaning Procedure

1) Dilute IMS-II Sanitizer or a 5.25% Sodium Hypochlorite solution with water (Add 1.5 fl. oz. (44.3 ml) of sanitizer to 3 gal. (11.36 l) of water).

Note: IMS-II Sanitizer, Part #SA0004, is available through your Hoshizaki Dealer.

2) Remove the Insulation Panel.

3) Pour the sanitizing solution into the Water Tank.

4) Replace the Insulation Panel and the Front Panel in their correct position.

Note: Make sure that the Control Switch is in the “WASH” position and the Cleaning Valve is open.

5) Turn on the power supply, and start the sanitizing process.

6) Turn off the power supply after 15 minutes.

7) Remove the Front Panel.

8) Remove one end of the Pump Tubing. Drain the Water Tank. Replace the Pump Tubing in its correct position.

9) Repeat the above steps 14) through 25) in “[a] CLEANING PROCEDURE” two times to rinse thoroughly.

10) Close the Cleaning Valve.

11) Move the Control Switch to the “ICE” position.

12) Replace the Front Panel and the Base Cover in their correct position.

13) Clean the Storage Bin with water.

14) Turn on the power supply, and start the automatic icemaking process.

2. MAINTENANCE

IMPORTANT

This icemaker must be maintained individually, referring to the instruction manual and labels provided with the icemaker.

1) Stainless Steel Exterior

To prevent corrosion, wipe the exterior occasionally with a clean and soft cloth. Use a damp cloth containing a neutral cleaner to wipe off oil or dirt build up.

2) Storage Bin and Scoop

- Wash your hands before removing ice. Use the Plastic Scoop provided (Accessory).
- The Storage Bin is for ice use only. Do not store anything else in the Bin.
- Keep the Scoop clean. Clean it by using a neutral cleaner and rinse thoroughly.
- Clean the bin liner by using a neutral cleaner. Rinse thoroughly after cleaning.

3) Air Filter (Air-cooled model only)

A plastic mesh air filter removes dirt or dust from the air, and keeps the Condenser from getting clogged. As the Filter gets clogged, the icemaker's performance will be reduced. Check the Filter at least twice a month. When clogged, use warm water and a neutral cleaner to wash the Filter.

4) Condenser (Except water-cooled model)

Check the Condenser once a year, and clean if required by using a brush or vacuum cleaner. More frequent cleaning may be required depending on the location of the icemaker.

HOSHIZAKI

HOSHIZAKI AMERICA, INC.

618 HIGHWAY 74 SOUTH
PEACHTREE CITY, GA 30269
U.S.A.

PHONE: 770-487-2331

91A1KH10B