

Hoshizaki America, Inc.

Stackable Crescent Cuber

Models

KM-130ISAH-E

KM-130ISVWH-E

KM-130ISRH-E



“A Superior Degree
of Reliability”

www.hoshizaki.com

PARTS LIST

CE 89/336
73/23

Number: 71348
Issued: 11-29-2012
Revised: 9-14-2015

CONTENTS

- Auxiliary Codes..... 3
- Note About Ordering Parts 3
- A. Main Assembly & Refrigeration Circuit 4
 - KM-1301SAH-E 4
 - KM-1301SWH-E 7
 - KM-1301SRH-E..... 9
- B. Water Circuit 11
- C. Control Box Assembly 14
- D. Accessories & Labels 16

Auxiliary Codes

KM-1301SAH-E

T-0 December 2008
U-0 February 2009
U-1 September 2009
V-0 January 2010
V-1 June 2010
V-2 July 2010
A-0 January 2011
A-1 October 2011
B-0 January 2012
C-0 January 2013
D-0 January 2014
E-0 January 2015
E-1 August 2015

KM-1301SRH-E

V-0 September 2010
A-0 January 2011
B-0 August 2012
C-0 January 2013
D-0 January 2014
D-1 August 2014
E-0 January 2015

KM-1301SWH-E

V-0 September 2010
A-0 January 2011
A-1 October 2011
C-1 March 2013
D-0 June 2014
E-0 May 2015

Auxiliary Code Breakdown

The auxiliary code is the first two characters in the serial number. The first character indicates the year. Years progress or regress in alphabetical order. The series runs from "A" through "V" and the letters "I" and "O" are skipped. The second character indicates significant part changes within a year. Base is "0" and this number advances for each change.

Note About Ordering Parts

Most assemblies cannot be ordered as complete units; parts in the assemblies generally must be ordered separately.

IMPORTANT

IEC standards require that the clamping means of earthing terminals be adequately secured against accidental loosening and that accessible metal parts of the icemaker which may become live in the event of an insulation fault be permanently and reliably connected to an earthing terminal within the icemaker or to the earthing contact of the icemaker inlet. This is accomplished in this icemaker through the use of stainless steel lock washers.

A. Main Assembly & Refrigeration Circuit

KM-1301SAH-E

T-0 to E-1

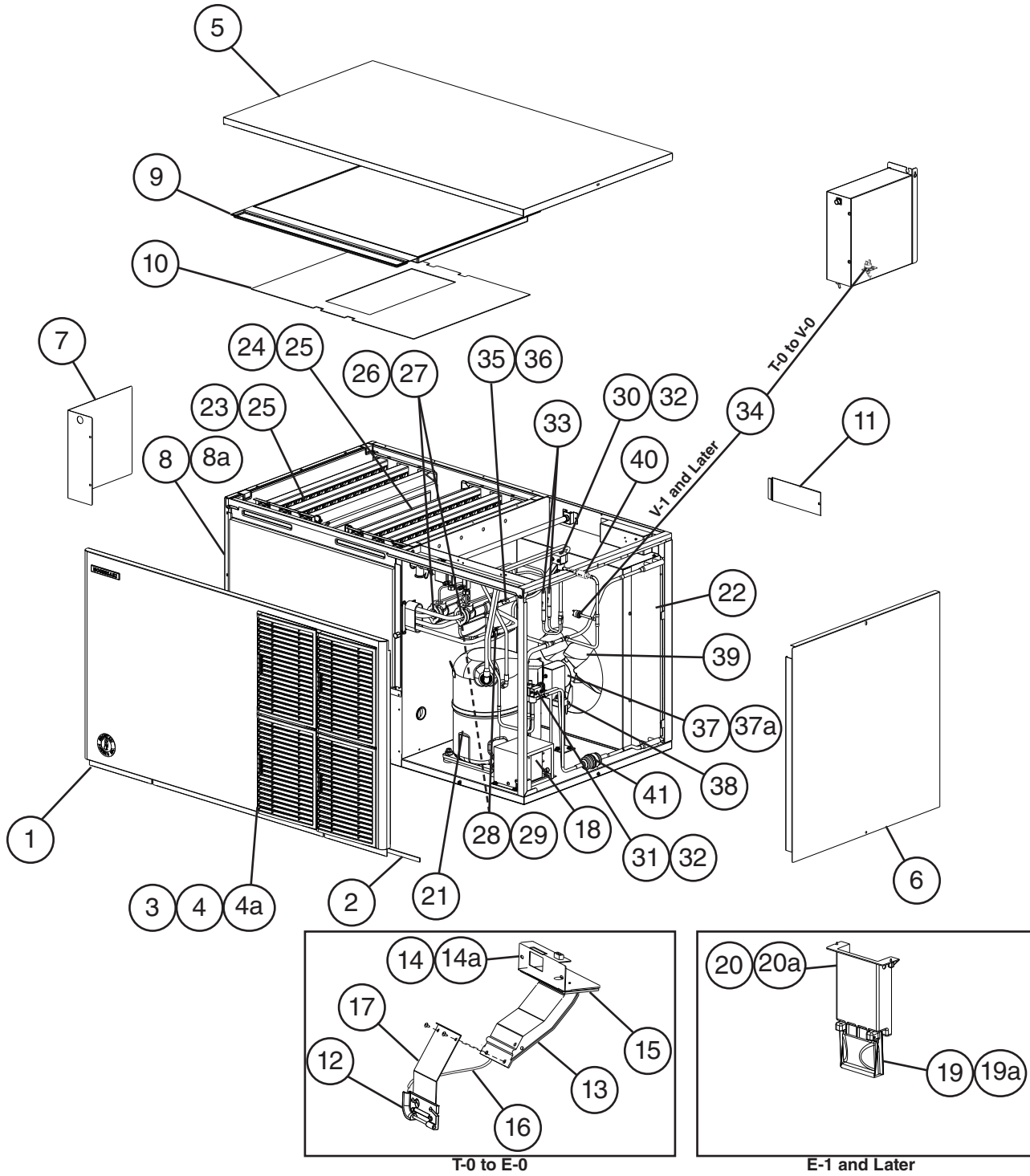

Title: A. Main Assembly & Refrigeration Circuit Model: KM-1301SAH-E												
Index No.	Description	Material or Model Number	Part Number	Required Number								
				T-0 to V-0	V-1 to A-0	A-1 to E-0	E-1					
Main Assembly												
1	Front Panel		2A2224-02	1	1	1	1					
2	Gasket	L=1219 mm	4A0808L02	1	1	1	1					
3	Air Filter		2A2063G01	4	4	4	4					
4	Louver		1A0548-01	4	4	4	4					
4a	Push Retainer		4A2414-01	12	12	12	12					
5	Top Panel		2A2255-01	1	1	1	1					
6	Right Side Panel		2A2226G01	1	1	1	1					
7	Control Box Cover		3A2386-01	1	1	1	1					
8	Front Insulation		324215G01	1	1	1	1					
8a	Thumbscrew		415949G12	1	1	1	1					
9	Top Insulation		324216G01	1	1	1	1					
10	Spacer		324321-01	1	1	1	1					
11	Junction Box Cover		4A1767-01	1	1	1	1					
12	Bin Control Bulb Holder		3A3903-01	1	1	1	-					
13	Bin Control Bulb Holder C		216340G01	1	1	1	-					
14	Bin Control Bulb Holder D		328742-01	1	1	1	-					
14a	Thumbscrew		415949G12	2	2	2	-					
15	Spacer		439727-01	1	1	1	-					
16	Silicone Hose	L=285 mm	773013812	1	1	1	-					
17	Bin Control Extension Bracket		3A0408-01	1	1	1	-					
18	Main Transformer		4A5262-01	1	1	1	1					
19	Mechanical Bin Control		2A4393G01				1					
19a	Thumbscrew		415949G12				2					
20	Bin Control Mounting Bracket		3A5726-01				1					
20a	Thumbscrew		415949G12				2					
Refrigeration Circuit												
21	Compressor		4A1749-01	1	1	-						
			4A1749-03			1	1					
22	Condenser		213621-01	1	1	1	1					
23	Left Evaporator Bank	HS-0208	2A0414G02	1	1	1	1					
24	Right Evaporator Bank	HS-0209	2A0415G02	1	1	1	1					
25	Separator Hook		324152-01	8	8	8	8					
26	Thermostatic Expansion Valve		4A1482-01	2	2	2	2					
27	Thermostatic Expansion Valve Cover		3A0944-01	2	2	2	2					
28	Thermostatic Expansion Valve Bulb Holder		3A0107-01	2	2	2	2					
29	Clamp		443461-02	2	2	2	2					
30	Hot Gas Valve Body		4A3978-01	1	1	1	1					
31	Liquid Line Valve Body		4A3276-01	1	1	1	1					
32	Valve Coil		4A3277-01	2	1	1	1					
33	Check Valve		4A1373-01	2	2	2	2					
34	High-Pressure Switch		433441-07	1	-							
			463180-04		1	1	1					
35	Thermistor	L=1050 mm	429006-03	1	1	1	1					
36	Thermistor Holder		427430-01	1	1	1	1					

Title: A. Main Assembly & Refrigeration Circuit Model: KM-1301SAH-E											
Index No.	Description	Material or Model Number	Part Number	Required Number							
				T-0 to V-0	V-1 to A-0	A-1 to E-0	E-1				
37	Fan Motor		4A3158-01	1	1	1	1				
37a	Self-Locking Nut	8-32	7N2110832	4	4	4	4				
38	Fan Motor Capacitor	5MFD, 250VAC	443192-02	1	1	1	1				
39	Fan Blade		4A3959-01	1	1	1	1				
40	Strainer		441569-02	1	1	1	1				
41	Drier		4A2666-01	1	1	1	1				

A. Main Assembly & Refrigeration Circuit
KM-1301SWH-E
V-0 to E-0

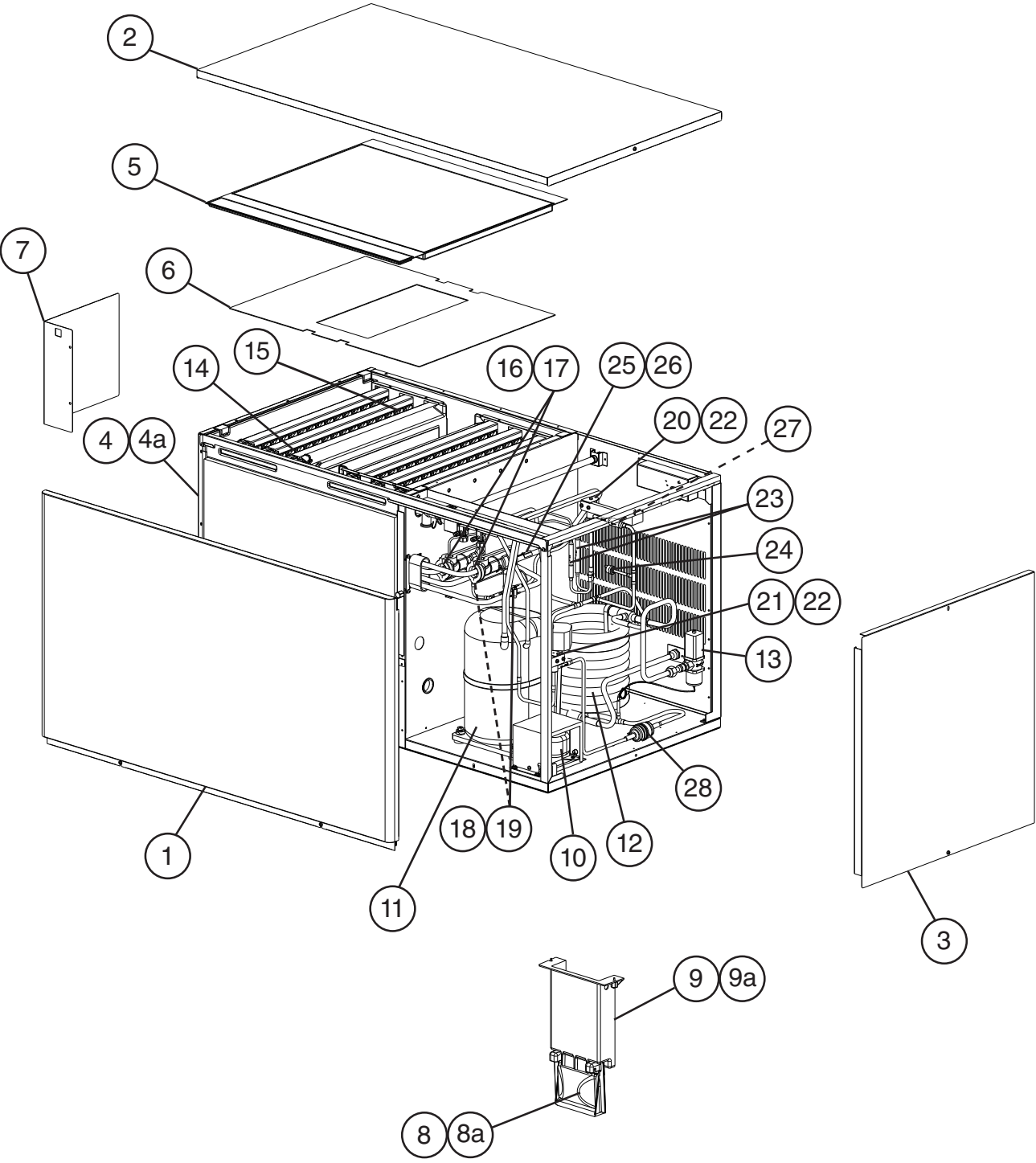

Title: A. Main Assembly & Refrigeration Circuit Model: KM-1301SWH-E												
Index No.	Description	Material or Model Number	Part Number	Required Number								
				V-0 A-0	A-1 to C-0	C-1 to E-0						
Main Assembly												
1	Front Panel		2A2224-01	1	1	1						
2	Top Panel		2A2255-01	1	1	1						
3	Right Side Panel		2A2226G01	1	1	1						
4	Front Insulation		324215G01	1	1	1						
4a	Thumbscrew		415949G12	1	1	1						
5	Top Insulation		324216G01	1	1	1						
6	Spacer		324321-01	1	1	1						
7	Control Box Cover		3A2386-01	1	1	1						
8	Mechanical Bin Control		2A4393G01	1	1	1						
8a	Thumbscrew		415949G12	2	2	2						
9	Bin Control Mounting Bracket		3A5726-01	1	1	1						
9a	Thumbscrew		415949G12	2	2	2						
10	Main Transformer		4A5262-01	1	1	1						
Refrigeration Circuit												
11	Compressor		4A1749-01	1	-							
			4A1749-03		1	1						
12	Condenser	HS-0163	2A2359G04	1	1	-						
			3A7236-01			1						
13	Water Regulating Valve		4A0911-07	1	1	1						
14	Left Evaporator Bank	HS-0208	2A0414G02	1	1	1						
15	Right Evaporator Bank	HS-0209	2A0415G02	1	1	1						
16	Thermostatic Expansion Valve		4A1482-01	2	2	2						
17	Thermostatic Expansion Valve Cover		3A0944-01	2	2	2						
18	Thermostatic Expansion Valve Bulb Holder		3A0107-01	2	2	2						
19	Clamp		443461-02	2	2	2						
20	Hot Gas Valve Body		4A3978-01	1	1	1						
21	Liquid Line Valve Body		4A3276-01	1	1	1						
22	Valve Coil		4A3277-01	2	2	2						
23	Check Valve		4A1373-01	2	2	2						
24	High-Pressure Switch		463180-05	1	1	1						
25	Thermistor	L=1050 mm	429006-03	1	1	1						
26	Thermistor Holder		427430-01	1	1	1						
27	Strainer		441569-02	1	1	1						
28	Drier		4A2666-01	1	1	1						

A. Main Assembly & Refrigeration Circuit
KM-1301SRH-E
 V-0 to E-0

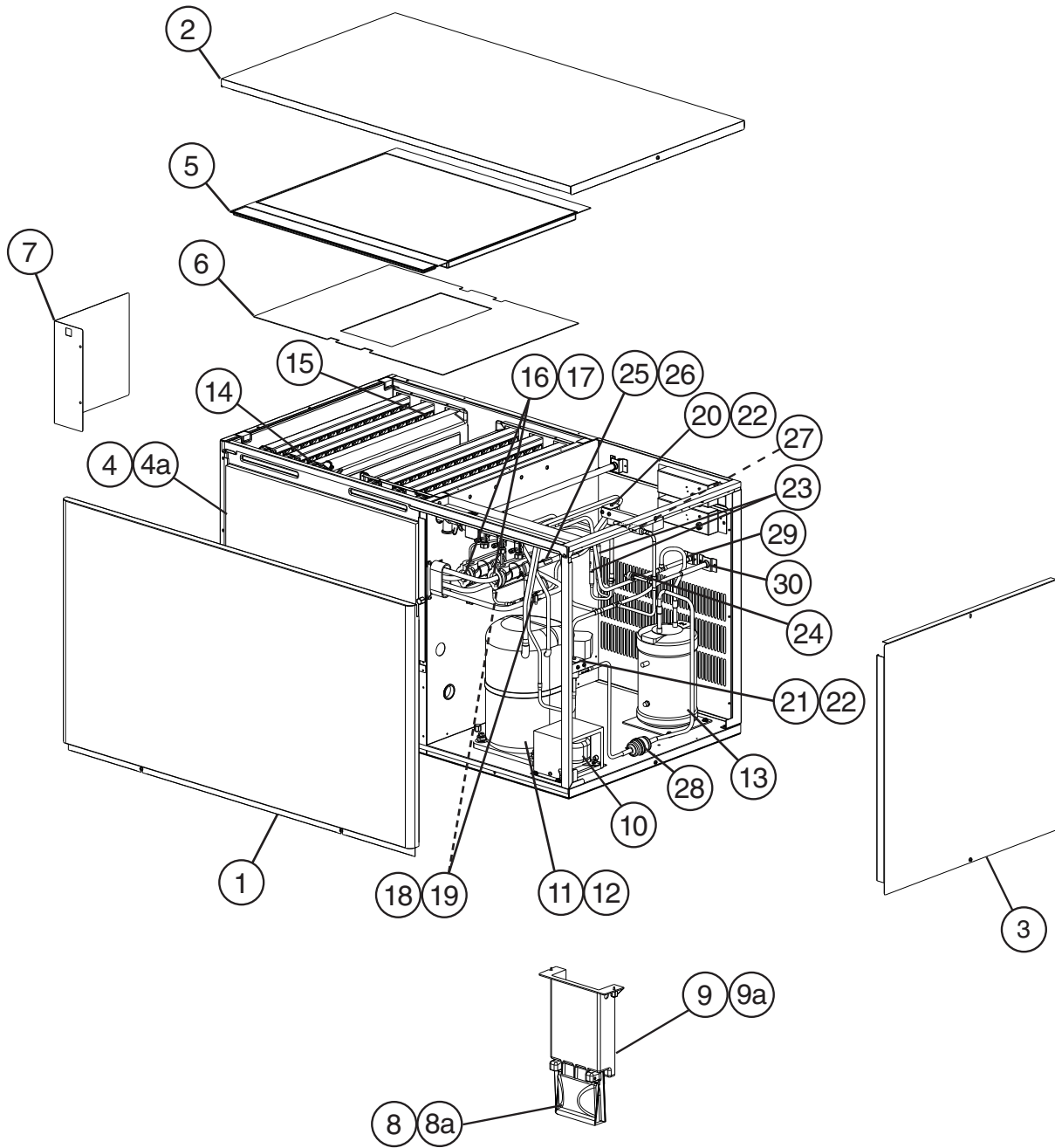

Title: A. Main Assembly & Refrigeration Circuit Model: KM-1301SRH-E												
Index No.	Description	Material or Model Number	Part Number	Required Number								
				V-0 A-0	B-0 to E-0							
Main Assembly												
1	Front Panel		2A2224-01	1	1							
2	Top Panel		2A2255-01	1	1							
3	Right Side Panel		2A2226G01	1	1							
4	Front Insulation		324215G01	1	1							
4a	Thumbscrew		415949G12	1	1							
5	Top Insulation		324216G01	1	1							
6	Spacer		324321-01	1	1							
7	Control Box Cover		3A2386-01	1	1							
8	Mechanical Bin Control		2A4393G01	1	1							
8a	Thumbscrew		415949G12	2	2							
9	Bin Control Mounting Bracket		3A5726-01	1	1							
9a	Thumbscrew		415949G12	2	2							
10	Main Transformer		4A5262-01	1	1							
Refrigeration Circuit												
11	Compressor (B-0 and later utilize external crankcase heater-item 12)		4A1749-02	1	-							
			4A1749-03		1							
12	Crankcase Heater		4A5397-02		1							
13	Receiver Tank		437652-01	1	1							
14	Left Evaporator Bank	HS-0208	2A0414G02	1	1							
15	Right Evaporator Bank	HS-0209	2A0415G02	1	1							
16	Thermostatic Expansion Valve		4A1482-01	2	2							
17	Thermostatic Expansion Valve Cover		3A0944-01	2	2							
18	Thermostatic Expansion Valve Bulb Holder		3A0107-01	2	2							
19	Clamp		443461-02	2	2							
20	Hot Gas Valve Body		4A3978-01	1	1							
21	Line Valve Body		4A3276-01	1	1							
22	Valve Coil		4A3277-01	2	2							
23	Check Valve		4A1373-01	2	2							
24	High-Pressure Switch		463180-04	1	1							
25	Thermistor	L=1050 mm	429006-03	1	1							
26	Thermistor Holder		427430-01	1	1							
27	Strainer		441569-02	1	1							
28	Drier		4A2666-01	1	1							
29	Liquid Line Coupling		433751G01	1	1							
30	Discharge Line Coupling		434136G01	1	1							

B. Water Circuit
KM-1301S_H-E
 T-0 to E-1

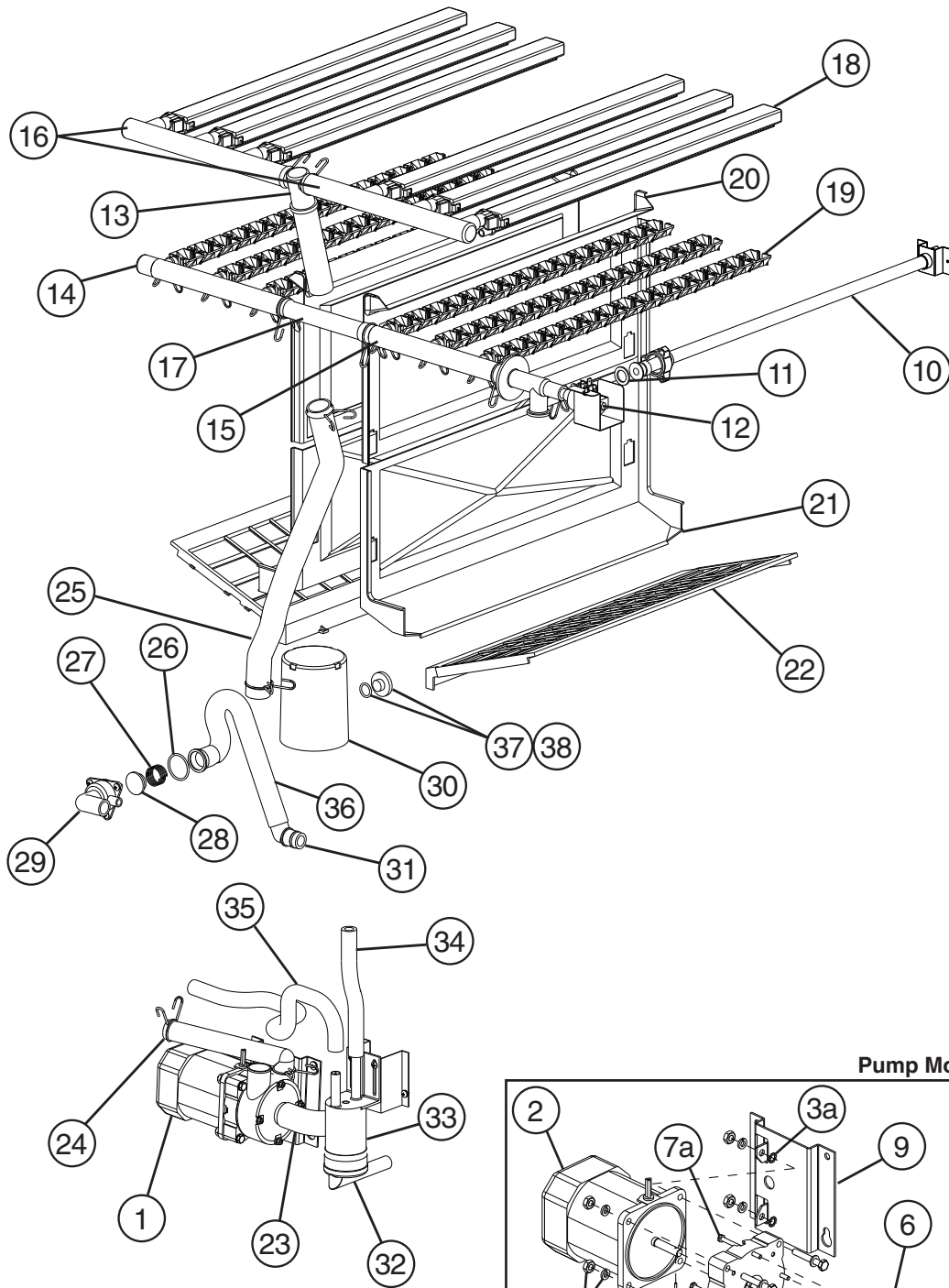

Pump Motor Assembly

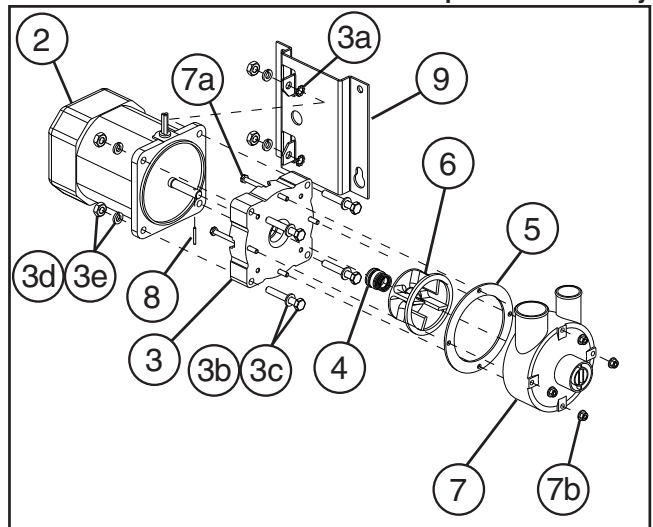

Title: B. Water Circuit Model: KM-1301S_H-E

Index No.	Description	Material or Model Number	Part Number	Required Number																
				T-0 to E-0 (D)	E-0 to E-1															
1	Pump Motor Assembly (includes items 2 through 8)	S-0862	215692A04	1	1															
2	Pump Motor		2U0106-01	1	1															
3	Pump Motor Flange		215662-01	1	1															
3a	Tooth Washer		7R22-0600	2	2															
3b	Hex Bolt	6x40, SS	7B02-0640	4	4															
3c	Flat Washer		7W22-0600	4	4															
3d	Split Lock Washer		7L22-0600	4	4															
3e	Hex Nut		7N12-0600	4	4															
4	Mechanical Seal		4A3820-01	1	1															
5	Packing		428547-01	1	1															
6	Impeller		334706G01	1	1															
7	Pump Housing		213687-01	1	1															
7a	Hex Bolt	4x55, SS	7B02-0455	4	4															
7b	Hex Flange Nut		7J02-0400	4	4															
8	Pin		4A0648-01	1	1															
9	Pump Motor Bracket		323904-01	1	1															
10	Water Supply Pipe		4A5216G04	1	1															
11	Rubber Gasket		413854-03	1	1															
12	Inlet Water Valve		4A5251-02	1	1															
13	Distributor		438276G01	1	1															
14	Distributor Hose A		325738-01	1	1															
15	Distributor Hose B		325738-02	1	1															
16	Distributor Hose C		323985-01	2	2															
17	Joint Pipe		439297-01	1	1															
18	Spray Tube		437049G01	6	6															
19	Spray Guide		208586-01	18	18															
20	Separator A		213622-01	2	2															
21	Separator B		2A0100-01	2	2															
22	Cube Guide		214243-01	2	2															
23	Hose A		435091-01	1	1															
24	Hose B		436599-01	1	1															
25	Vinyl Hose	L=420 mm	7716-2732	1	1															
26	O-Ring		7611-G035	1	1															
27	Drain Valve Spring		322110-01	1	1															
28	Drain Valve Seat		433705-01	1	1															
29	Drain Valve Housing		323613-01	1	1															
30	Overflow Cap		323978-01	1	1															
31	Drain Valve O-Ring		7611-P018	1	-															
32	Float Switch Connector		426799-04	1	1															
33	Float Switch		4A3624-01	1	1															
34	Silicone Hose	L=140 mm	773013812	1	1															
35	Silicone Hose	L=390 mm	773013896	1	1															
36	Drain Hose		324757-01	1	1															
37	Drain Plug		309246-01	1	1															
38	Drain Plug O-Ring		7611-P015	1	1															

Title: B. Water Circuit Model: KM-1301S_H-E											
Index No.	Description	Material or Model Number	Part Number	Required Number							
				T-0 to E-0 (D)	E-0 to E-1						
Hose Clamps											
	Hose Clamp	13.5 mm	427443-07	6	6						
	Hose Clamp	18 mm	427443-05	1	1						
	Hose Clamp	25 mm	427443-03	7	7						
	Hose Clamp	32 mm	427443-09	2	2						

C. Control Box Assembly

KM-1301S_H-E

T-0 to E-1

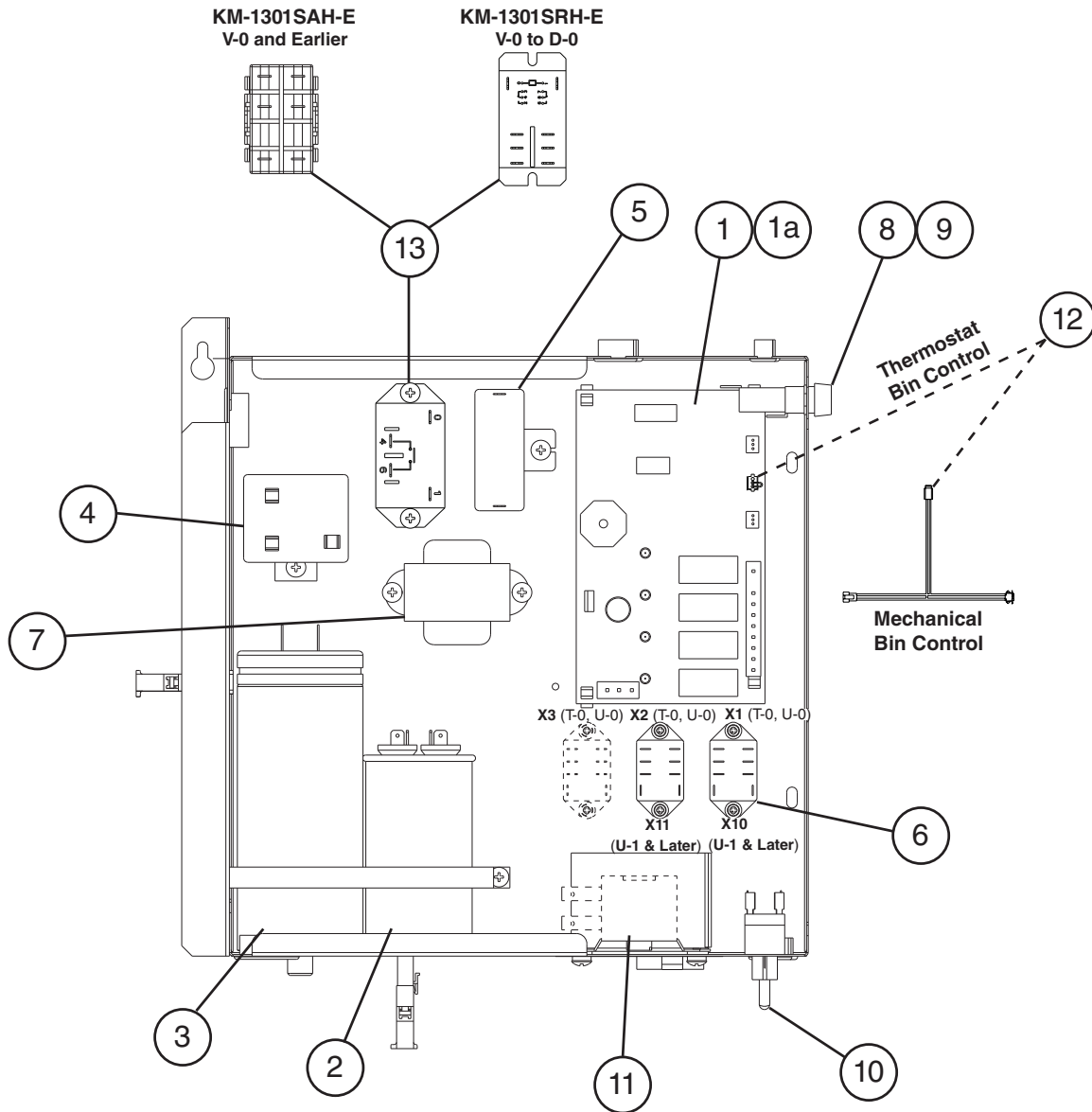

X1 (T-0, U-0) or X10 (U-1 and later) - Pump Direction Relay
X2 (T-0, U-0) or X11 (U-1 and later) - Control Relay for X1 (T-0, U-0) or X10 (U-1 and later) Pump Direction Relay
X3 - Harvest Pump Timer Relay (Auxiliary Code T-0, U-0)

Title: C. Control Box Assembly Model: KM-1301S_H-E											
Index No.	Description	Material or Model Number	Part Number	Required Number							
				T-0 to V-0	V-1 to D-0	D-1 to E-0	E-1				
1	"G" Control Board		2A3792-01	1	1	1	1				
1a	Control Board Support		4A0336-03	4	4	4	4				
2	Run Capacitor	35MFD, 440VAC	3A2005-12	1	1	1	1				
3	Start Capacitor	160MFD, 330VAC	4A1094-01	1	1	1	1				
4	Start Relay		4A1107-13	1	1	1	1				
5	Pump Motor Capacitor	15.0MFD, 250VAC	4A2128-02	1	1	1	1				
6	Relay (X1, X2, and X3 - T-0 and U-0) (X10 and X11 - U-1 and later)		406132-07	3	2	2	2				
7	Control Transformer		3A0172-01	1	1	1	1				
8	Fuse Holder		4A5443-01	1	1	1	1				
9	Fuse	AGC-10A, 250VAC	4A0893-07	1	1	1	1				
10	Control Switch		4A2436-01	1	1	1	1				
11	Bin Control Thermostat	KM-1301SAH-E	4A2879-02	1	1	1	-				
12	K-4 Jumper	KM-1301SAH-E	4A4883G01	1	1	1	-				
	Bin Control Wire Harness	KM-1301SAH-E	4A5197G01				1				
		KM-1301SWH-E KM-1301SRH-E			1	1	1				
13	Magnetic Contactor	KM-1301SAH-E	428393-01	1	-						
	Compressor Relay	KM-1301SAH-E	4A3140-01		1	1	1				
		KM-1301SWH-E			1	1	1	1			
		KM-1301SRH-E	4A5096-01	1	1	-					
			4A3140-01			1	1				

D. Accessories & Labels
KM-1301S_H-E
 T-0 to E-1

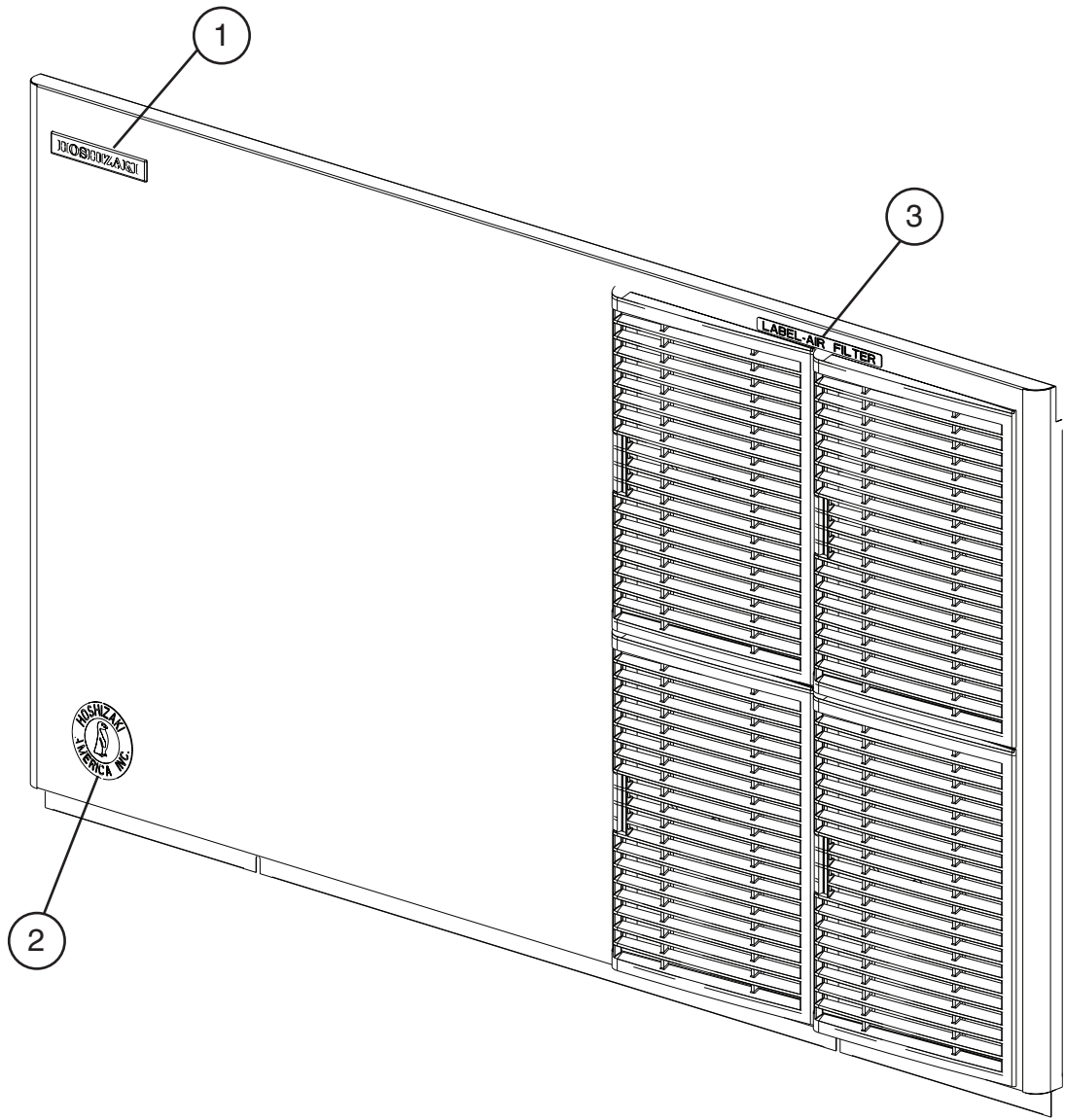

Title: D. Accessories & Labels Model: KM-1301S_H-E							Required Number					
Index No.	Description	Material or Model Number	Part Number	T-0 to D-0 (G)	D-0 (H) to E-1							
1	Hoshizaki Emblem Label		4A0560-01	1	1							
2	Penguin Label		4A0526-01	1	1							
3	Air Filter Label	KM-1301SAH-E	426177-01	1	-							
4	Universal Brace		4A0363-01	2	2							
4a	Hex Bolt	5x12, SS	7B02-0512	4	4							