

# Hoshizaki America, Inc.

## Stackable Crescent Cuber

### Models

KM-130 ISAH-E

KM-130 ISWH-E

KM-130 ISRH-E



“A Superior Degree  
of Reliability”

[www.hoshizaki.com](http://www.hoshizaki.com)

## SERVICE MANUAL



Number: 73181  
Issued: 4-12-2011

**IMPORTANT**

Only qualified service technicians should install, service, and maintain the icemaker. No service or maintenance should be undertaken until the technician has thoroughly read this Service Manual. Failure to service and maintain the equipment in accordance with this manual may adversely affect safety, performance, component life, and warranty coverage.

Hoshizaki provides this manual primarily to assist qualified service technicians in the service and maintenance of the icemaker.

Should the reader have any questions or concerns which have not been satisfactorily addressed, please call, write, or send an e-mail message to the Hoshizaki Technical Support Department for assistance.

HOSHIZAKI AMERICA, INC.  
618 Highway 74 South  
Peachtree City, GA 30269

Attn: Hoshizaki Technical Support Department

Phone: 1-800-233-1940 Technical Support  
(770) 487-2331

Fax: 1-800-843-1056  
(770) 487-3360

E-mail: techsupport@hoshizaki.com

Web Site: [www.hoshizaki.com](http://www.hoshizaki.com)

**NOTE:** To expedite assistance, all correspondence/communication **MUST** include the following information:

- Model Number \_\_\_\_\_
- Serial Number \_\_\_\_\_
- Complete and detailed explanation of the problem.

## IMPORTANT

This manual should be read carefully before the icemaker is serviced or maintenance operations are performed. Only qualified service technicians should install, service, and maintain the icemaker. Read the warnings contained in this booklet carefully as they give important information regarding safety. Please retain this booklet for any further reference that may be necessary.

## CONTENTS

Important Safety Information .....	5
I. Specifications.....	6
A. Icemaker .....	6
1. KM-1301SAH-E (air-cooled).....	6
2. KM-1301SWH-E (water-cooled).....	7
3. KM-1301SRH-E (remote air-cooled).....	8
B. Condenser Unit .....	9
II. General Information.....	11
A. Construction.....	11
1. KM-1301SAH-E (air-cooled).....	11
2. KM-1301SWH-E (water-cooled).....	12
3. KM-1301SRH-E (remote air-cooled).....	13
B. Sequence of Operation .....	14
1. Sequence Cycles and Shutdown .....	14
a) 1-Minute Fill Cycle .....	14
b) Initial Harvest Cycle .....	14
c) Freeze Cycle .....	15
d) Pump-Out Cycle.....	15
e) Harvest Cycle.....	15
f) Shutdown.....	15
2. Sequence Flow Chart.....	17
C. Control Board .....	18
1. Control Board Layout .....	19
a) LED Lights and Audible Alarm Safeties .....	20
2. Controls and Adjustments.....	21
a) Default Dip Switch Settings.....	21
b) Harvest Timer (S4 dip switch 1 & 2).....	21
c) Pump-Out Timer (S4 dip switch 3 & 4).....	22
d) Pump-Out Frequency Control (S4 dip switch 5 & 6).....	22
e) Harvest Pump Timer (S4 dip switch 7).....	23
f) Factory Use (S4 dip switch 8) .....	23
g) Freeze Timer (S4 dip switch 9 & 10) .....	23
h) Float Switch Control (S5 dip switch 1) .....	24
i) Refill Counter (S5 dip switch 2 through 5).....	24
D. Control Switch .....	24

III. Technical Information .....	25
A. Water Circuit and Refrigeration Circuit .....	25
1. KM-1301SAH-E (air-cooled) .....	25
2. KM-1301SWH-E (water-cooled) .....	26
3. KM-1301SRH-E (remote air-cooled) .....	27
B. Wiring Diagrams .....	28
1. Auxiliary Code T-0, U-0 .....	28
a) KM-1301SAH-E (air-cooled) .....	28
2. Auxiliary Code U-1 and Later .....	29
a) KM-1301SAH-E (air-cooled) .....	29
b) KM-1301SWH-E (water-cooled) .....	30
c) KM-1301SRH-E (remote air-cooled) .....	31
C. Performance Data .....	32
1. KM-1301SAH-E (air-cooled) .....	32
2. KM-1301SWH-E (water-cooled) .....	33
3. KM-1301SRH-E (remote air-cooled) .....	34
IV. Service Diagnosis .....	35
A. Diagnostic Procedure .....	35
B. Control Board Check .....	39
C. Bin Control Check .....	40
1. Thermostatic Bin Control Check: KM-1301SAH-E .....	40
2. Mechanical Bin Control Check and Cleaning: KM-1301SWH-E, KM-1301SRH-E .....	40
a) Mechanical Bin Control Check .....	40
b) Mechanical Bin Control Cleaning .....	42
D. Float Switch Check and Cleaning .....	43
1. Float Switch Check .....	43
2. Float Switch Cleaning .....	44
E. Thermistor Check .....	45
F. Adjustment of Water Regulating Valve (water-cooled model) .....	45
G. Diagnostic Charts .....	46
1. No Ice Production .....	46
2. Freeze Up .....	48
3. Low Ice Production .....	50
V. Replacement of Components .....	51
A. Service for Refrigerant Lines .....	51
1. Refrigerant Recovery .....	51
2. Brazing .....	52
3. Evacuation and Recharge (R-404A) .....	52
B. Important Notes for Component Replacement .....	54
VI. Cleaning and Maintenance .....	55
A. Cleaning and Sanitizing Instructions .....	55
1. Cleaning Procedure .....	55
2. Sanitizing Procedure - Following Cleaning Procedure .....	57
B. Maintenance .....	58
C. Preparing the Icemaker for Long Storage .....	58

---

## Important Safety Information

Throughout this manual, notices appear to bring your attention to situations which could result in death, serious injury, or damage to the unit.

**⚠ WARNING** Indicates a hazardous situation which could result in death or serious injury.

**CAUTION** Indicates a situation which could result in damage to the unit.

**IMPORTANT** Indicates important information about the use and care of the unit.

### ⚠ WARNING

This icemaker should be destined only to the use for which it has been expressly conceived. Any other use should be considered improper and therefore dangerous. The manufacturer cannot be held responsible for injury or damage resulting from improper, incorrect, and unreasonable use.

**To reduce the risk of death, electric shock, serious injury, or fire, follow basic precautions including the following:**

- Only qualified service technicians should install, service, and maintain the icemaker.
- Hard-wired electrical connection is recommended. Electrical connection must meet national, state, and local electrical code requirements. Failure to meet these code requirements could result in death, electric shock, serious injury, fire, or severe damage to equipment.
- This unit requires an independent power supply. See the nameplate for proper voltage and breaker/fuse size. Failure to use a proper breaker or fuse can result in a tripped breaker, blown fuse, or damage to existing wiring. This could lead to heat generation or fire.
- **THE ICEMAKER MUST BE GROUNDED (EARTHED).** Failure to properly ground (earth) the icemaker could result in death or serious injury.
- Move the control switch to the "OFF" position and turn off the power supply before servicing. Lockout/Tagout to prevent the power supply from being turned back on inadvertently.
- Do not make any alterations to the unit. Alterations could result in electric shock, injury, fire, or damage to the unit.

#### **Additional Warning for Remote Air-Cooled Model**

- **THE REMOTE CONDENSER UNIT MUST BE GROUNDED (EARTHED).** The power supply and ground (earth) wire to the remote condenser unit are supplied from the icemaker. Failure to properly ground (earth) the remote condenser unit could result in death or serious injury.

# I. Specifications

## A. Icemaker

### 1. KM-1301SAH-E (air-cooled)

AC SUPPLY VOLTAGE	220-240/50/1			
AMPERAGE	11.8 A (5 Min. Freeze AT 109°F/WT 59°F)			
MINIMUM CIRCUIT AMPACITY	20 A			
MAXIMUM FUSE SIZE	20 A			
APPROXIMATE ICE PRODUCTION PER 24 HR. lb./day ( kg/day ) Reference without *marks	Ambient Temp. (°F)	WATER TEMP. (°F)		
		50	70	90
	70	*1114 (505)	1082 (491)	992 (450)
	80	1089 (494)	1039 (471)	924 (419)
	90	1082 (491)	*1004 (455)	897 (407)
	100	1048 (475)	979 (444)	799 (362)
FOR THE EUROPEAN MARKET		10/10°C	20/15°C	30/25°C
ICE CAPACITY lb./day (kg/day)		1288 (584)	1151 (522)	1025 (465)
SHAPE OF ICE	Crescent Cube			
ICE PRODUCTION PER CYCLE	29.1 lb. (13.2 kg) 1440 pcs.			
APPROXIMATE STORAGE CAPACITY	N/A			
ELECTRIC & WATER CONSUMPTION	90/70°F	70/50°F		
ELECTRIC W (kWH/100 lb.)	2120 (5.1)	1900 (4.1)		
WATER gal./24HR (gal./100 lb.)	157 (15.6)	537 (48.2)		
EXTERIOR DIMENSIONS (W×D×H)	48"×27-3/8"×27-3/8" (1219×695×695 mm)			
EXTERIOR FINISH	Stainless Steel, Galvanized Steel (Rear)			
WEIGHT	Net 275 lb. (125 kg), Shipping 315 lb. (143 kg)			
CONNECTIONS - ELECTRIC	Permanent - Connection			
- WATER SUPPLY	Inlet	1/2" FPT		
- DRAIN	Outlet	3/4" FPT		
- CONDENSATE DRAIN		3/8" OD Tube		
CUBE CONTROL SYSTEM	Float Switch			
HARVESTING CONTROL SYSTEM	Hot Gas and Water, Thermistor and Timer			
ICE MAKING WATER CONTROL	Timer Controlled. Overflow Pipe			
COOLING WATER CONTROL	N/A			
BIN CONTROL SYSTEM	Thermostat			
COMPRESSOR	Hermetic, Model CS14K6E-PFJ-237			
CONDENSER	Air-Cooled, Fin and Tube Type			
EVAPORATOR	Vertical Type, Stainless Steel and Copper			
REFRIGERANT CONTROL	Thermostatic Expansion Valve			
REFRIGERANT CHARGE	R404A, 3 lb. 9.1 oz. (1620 g)			
DESIGN PRESSURE	High 467 PSIG, Low 230 PSIG			
P.C. BOARD CIRCUIT PROTECTION	High Voltage Cut-Out (Internal)			
COMPRESSOR PROTECTION	Auto-Reset Overload Protector (Internal)			
REFRIGERANT CIRCUIT PROTECTION	Auto-Reset High-Pressure Control Switch			
LOW WATER PROTECTION	Float Switch			
ACCESSORIES -SUPPLIED	N/A			
-REQUIRED	Ice Storage Bin			
OPERATING CONDITIONS	VOLTAGE RANGE	198 - 254V		
	AMBIENT TEMP.	45 -100°F		
	WATER SUPPLY TEMP.	45 - 90°F		
	WATER SUPPLY PRESSURE	10 - 113 PSIG		

Note: We reserve the right to make changes in specifications and design without prior notice.

## 2. KM-1301SWH-E (water-cooled)

AC SUPPLY VOLTAGE	220-240/50/1			
AMPERAGE	10.7 A (5 Min. Freeze AT 109°F/WT 59°F)			
MINIMUM CIRCUIT AMPACITY	20 A			
MAXIMUM FUSE SIZE	20 A			
APPROXIMATE ICE PRODUCTION PER 24 HR. lb./day ( kg/day ) Reference without *marks	Ambient Temp. (°F)	WATER TEMP. (°F)		
		50	70	90
	70	*1330 (603)	1304 (591)	1239 (562)
	80	1310 (594)	1269 (576)	1189 (539)
	90	1304 (591)	*1240 (562)	1165 (528)
	100	1281 (581)	1222 (554)	1096 (497)
FOR THE EUROPEAN MARKET		10/10°C	20/15°C	30/25°C
ICE CAPACITY lb./day (kg/day)		1368 (621)	1324 (601)	1210 (549)
SHAPE OF ICE	Crescent Cube			
ICE PRODUCTION PER CYCLE	31 lb. (14 kg) 1440 pcs.			
APPROXIMATE STORAGE CAPACITY	N/A			
ELECTRIC & WATER CONSUMPTION	90/70°F	70/50°F		
ELECTRIC W (kWH/100 lb.)	1780 (3.5)	1780 (3.2)		
WATER gal./24HR (gal./100 lb.)	1643 (132.5)	1335 (100.4)		
WATER COOLED CONDENSER gal./24HR (gal./100 lb.)	1404 (113.2)	821 (61.7)		
EXTERIOR DIMENSIONS (W×D×H)	48"×27-3/8"×27-3/8" (1219×695×695 mm)			
EXTERIOR FINISH	Stainless Steel, Galvanized Steel (Rear)			
WEIGHT	Net 265 lb. (120 kg), Shipping 315 lb. (143 kg)			
CONNECTIONS - ELECTRIC	Permanent - Connection			
- WATER SUPPLY	Inlet	1/2" FPT	Cond. Inlet 1/2" FPT	
- DRAIN	Outlet	3/4" FPT	Cond. Outlet 3/8" FPT	
- CONDENSATE DRAIN	3/8" OD Tube			
CUBE CONTROL SYSTEM	Float Switch			
HARVESTING CONTROL SYSTEM	Hot Gas and Water, Thermistor and Timer			
ICE MAKING WATER CONTROL	Timer Controlled. Overflow Pipe			
COOLING WATER CONTROL	Water Regulating Valve			
BIN CONTROL SYSTEM	Mechanical Level Switch and Timer			
COMPRESSOR	Hermetic, Model CS14K6E-PFJ-237			
CONDENSER	Water-Cooled, Tube in Tube Type			
EVAPORATOR	Vertical Type, Stainless Steel and Copper			
REFRIGERANT CONTROL	Thermostatic Expansion Valve			
REFRIGERANT CHARGE	R404A, 2 lb. 10.3 oz. (1200 g)			
DESIGN PRESSURE	High 427 PSIG, Low 230 PSIG			
P.C. BOARD CIRCUIT PROTECTION	High Voltage Cut-Out (Internal)			
COMPRESSOR PROTECTION	Auto-Reset Overload Protector (Internal)			
REFRIGERANT CIRCUIT PROTECTION	Auto-Reset High-Pressure Control Switch			
LOW WATER PROTECTION	Float Switch			
ACCESSORIES -SUPPLIED	N/A			
-REQUIRED	Ice Storage Bin			
OPERATING CONDITIONS	VOLTAGE RANGE	198 - 254V		
	AMBIENT TEMP.	45 -100°F		
	WATER SUPPLY TEMP.	45 - 90°F		
	WATER SUPPLY PRESSURE	10 - 113 PSIG		

Note: We reserve the right to make changes in specifications and design without prior notice.

### 3. KM-1301SRH-E (remote air-cooled)

AC SUPPLY VOLTAGE	220-240/50/1			
AMPERAGE	12.3 A (5 Min. Freeze AT 109°F/WT 59°F)			
MINIMUM CIRCUIT AMPACITY	20 A			
MAXIMUM FUSE SIZE	20 A			
APPROXIMATE ICE PRODUCTION PER 24 HR. lb./day ( kg/day ) Reference without *marks	Ambient Temp. (°F)	WATER TEMP. (°F)		
		50	70	90
	70	*1270 (576)	1233 (559)	1160 (526)
	80	1241 (563)	1183 (537)	1100 (499)
	90	1233 (559)	*1142 (518)	1062 (482)
	100	1211 (549)	1123 (509)	988 (448)
FOR THE EUROPEAN MARKET		10/10°C	20/15°C	30/25°C
ICE CAPACITY lb./day (kg/day)		1312 (595)	1286 (583)	1163 (528)
SHAPE OF ICE	Crescent Cube			
ICE PRODUCTION PER CYCLE	32 lb. (14.3 kg)	1440 pcs.		
APPROXIMATE STORAGE CAPACITY	N/A			
ELECTRIC & WATER CONSUMPTION	90/70°F	70/50°F		
ELECTRIC W (kWH/100 lb.)	2070(4.4)	1950(3.7)		
WATER gal./24HR (gal./100 lb.)	228(20.0)	544(42.8)		
EXTERIOR DIMENSIONS (W×D×H)	48"×27-3/8"×27-3/8" (1219×695×695 mm)			
EXTERIOR FINISH	Stainless Steel, Galvanized Steel (Rear)			
WEIGHT	Net 255 lb. (116 kg), Shipping 315 lb. (143 kg)			
CONNECTIONS - ELECTRIC	Permanent - Connection			
- WATER SUPPLY	Inlet	1/2" FPT		
- DRAIN	Outlet	3/4" FPT		
- CONDENSATE DRAIN		3/8" OD Tube		
- REFRIGERATION	Discharge Line 1-1/16"-12 UNF Fitting (#10 PARKER)			
CIRCUIT	Liquid Line 5/8"-18 UNF Fitting (#6 PARKER)			
CUBE CONTROL SYSTEM	Float Switch			
HARVESTING CONTROL SYSTEM	Hot Gas and Water, Thermistor and Timer			
ICE MAKING WATER CONTROL	Timer Controlled. Overflow Pipe			
COOLING WATER CONTROL	N/A			
BIN CONTROL SYSTEM	Mechanical Level Switch and Timer			
COMPRESSOR	Hermetic, Model CS14K6E-PFJ-279			
CONDENSER	Air-Cooled Remote, Condenser Unit URC-14FE			
EVAPORATOR	Vertical Type, Stainless Steel and Copper			
REFRIGERANT CONTROL	Thermostatic Expansion Valve			
REFRIGERANT CHARGE	Headmaster (C.P.R.) on URC-14FE (190 PSIG) R404A, 10 lb. 5.8 oz. (4700 g) (Icemaker 5 lb. 15.2 oz. Cond. Unit 4 lb. 6.5 oz.)			
DESIGN PRESSURE	High 467 PSIG, Low 230 PSIG			
P.C. BOARD CIRCUIT PROTECTION	High Voltage Cut-Out (Internal)			
COMPRESSOR PROTECTION	Auto-Reset Overload Protector (Internal)			
REFRIGERANT CIRCUIT PROTECTION	Auto-Reset High Pressure Control Switch			
LOW WATER PROTECTION	Float Switch			
ACCESSORIES -SUPPLIED	N/A			
-REQUIRED	Ice Storage Bin Remote Condenser Unit (URC-14FE or Equivalent)			
OPERATING CONDITIONS	VOLTAGE RANGE	198 - 254 V		
	AMBIENT TEMP.	45 -100°F		
	WATER SUPPLY TEMP.	45 - 90°F		
	WATER SUPPLY PRESSURE	10 - 113 PSIG		

Note: We reserve the right to make changes in specifications and design without prior notice.



## B. Condenser Unit

### 1. URC-14FE

Units: mm [in.]

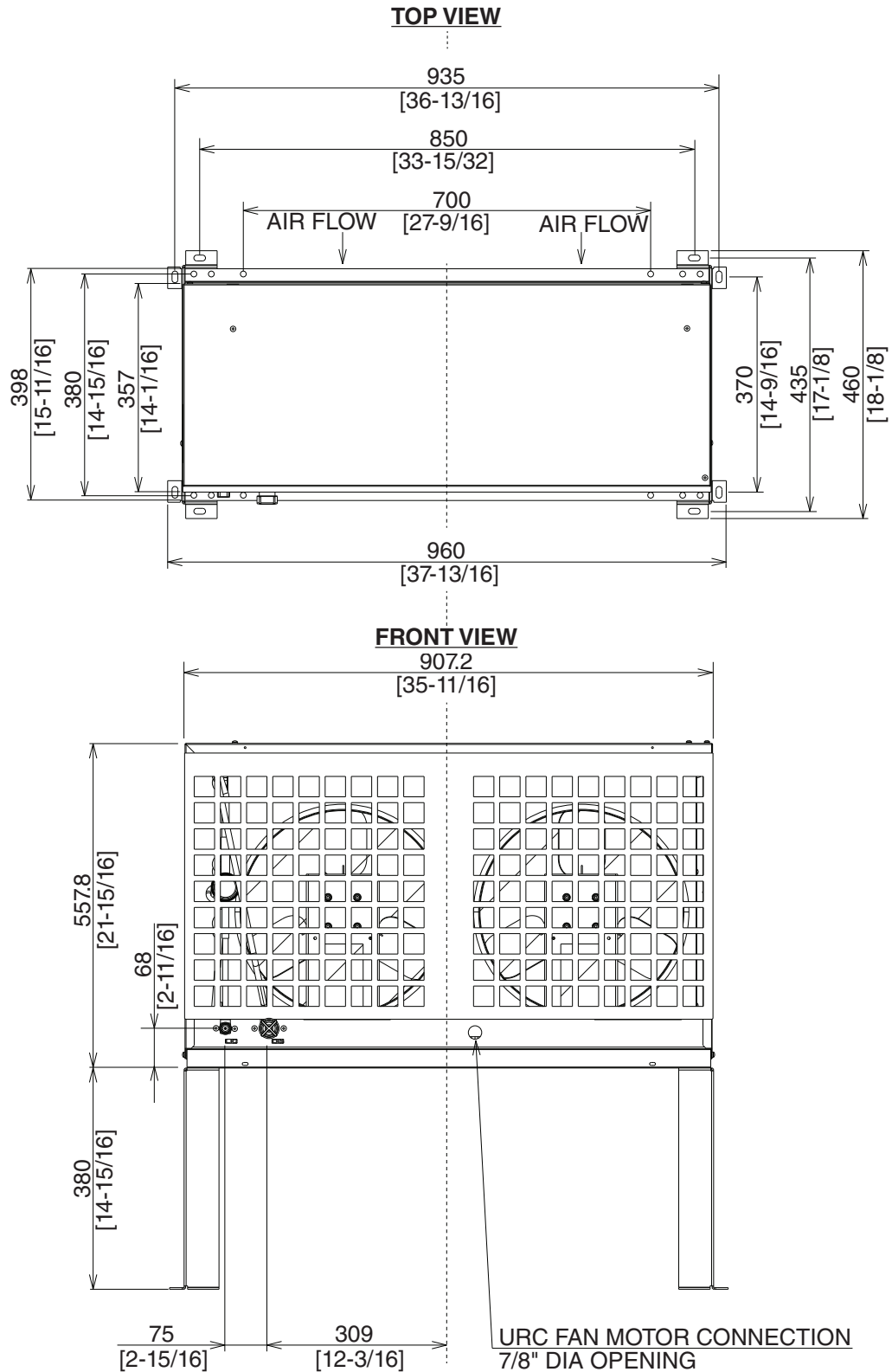

## SPECIFICATIONS

MODEL: URC-14FE

AC SUPPLY VOLTAGE	115/50/1 (Connection to Icemaker)		
FAN MOTOR	115 V	Total 2.6FLA	130W
EXTERIOR DIMENSIONS (WxDxH)	35-11/16"×15-11/16"×21-15/16" (907.2×398×557.8 mm)		
DIMENSIONS INCLUDING LEGS (WxDxH)	37-13/16"×18-1/8"×36-15/16" (960×460×937.8 mm)		
EXTERIOR FINISH	Galvanized Steel		
WEIGHT	Net 80 lb. ( 36 kg )    Shipping 87 lb. ( 39 kg )		
CONNECTIONS - ELECTRIC	Permanent - Connection		
- REFRIGERANT	Discharge Line 1-1/16"-12 UNF Fitting (#10 PARKER)		
	Liquid Line 5/8"-18 UNF Fitting (#6 PARKER)		
CONDENSER	Air-Cooled, Fin and Tube Type		
FAN MOTOR PROTECTION	Thermal Protection		
REFRIGERANT CONTROL	Headmaster (C.P.R.) (190 PSIG)		
REFRIGERANT CHARGE	R-404A    4 lb. 6.5 oz.    (2000 g)		
DESIGN PRESSURE	High 467 PSIG	32.2 Bar	
OPERATING CONDITIONS	VOLTAGE RANGE	104 ~ 127V	
	AMBIENT TEMP.	-20 ~ 122°F	
ACCESSORIES -SUPPLIED	Leg		2 pcs
	Hex Head Bolt w/Washer	8×16	8 pcs
	Hex Nut	8	8 pcs

Note: We reserve the right to make changes in specifications and design without prior notice.

## II. General Information

### A. Construction

#### 1. KM-1301SAH-E (air-cooled)

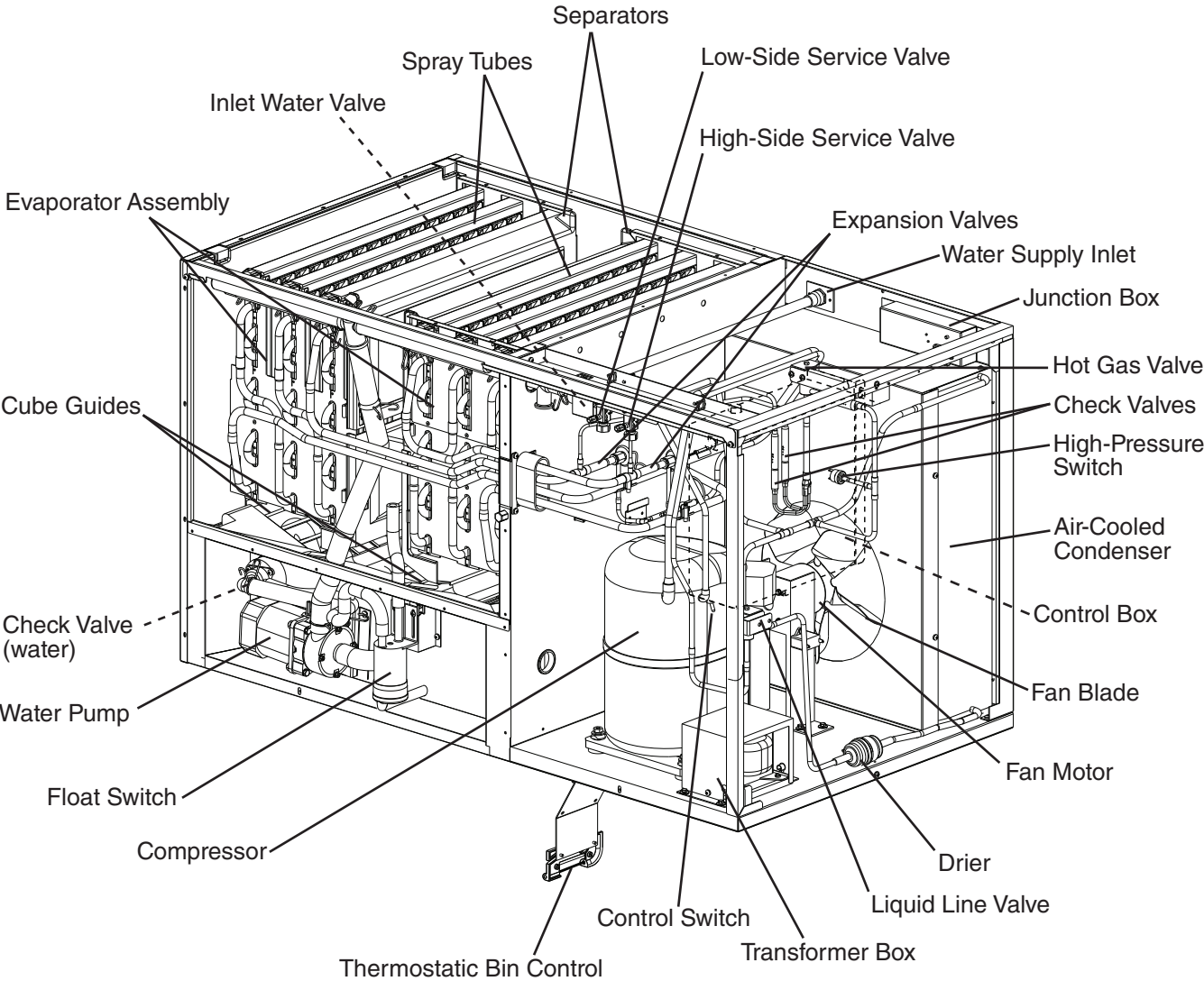

## 2. KM-1301SWH-E (water-cooled)

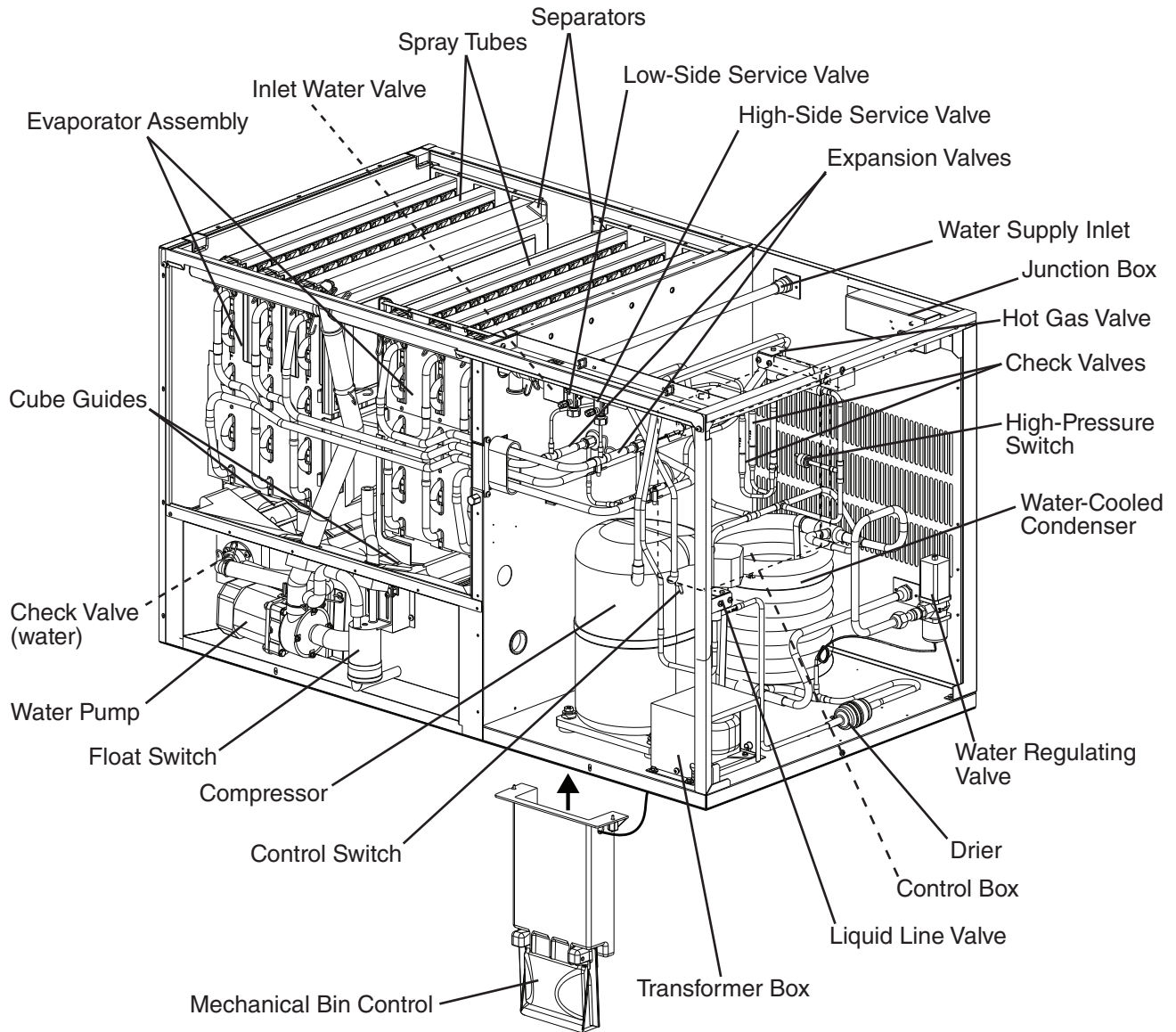

### 3. KM-1301SRH-E (remote air-cooled)

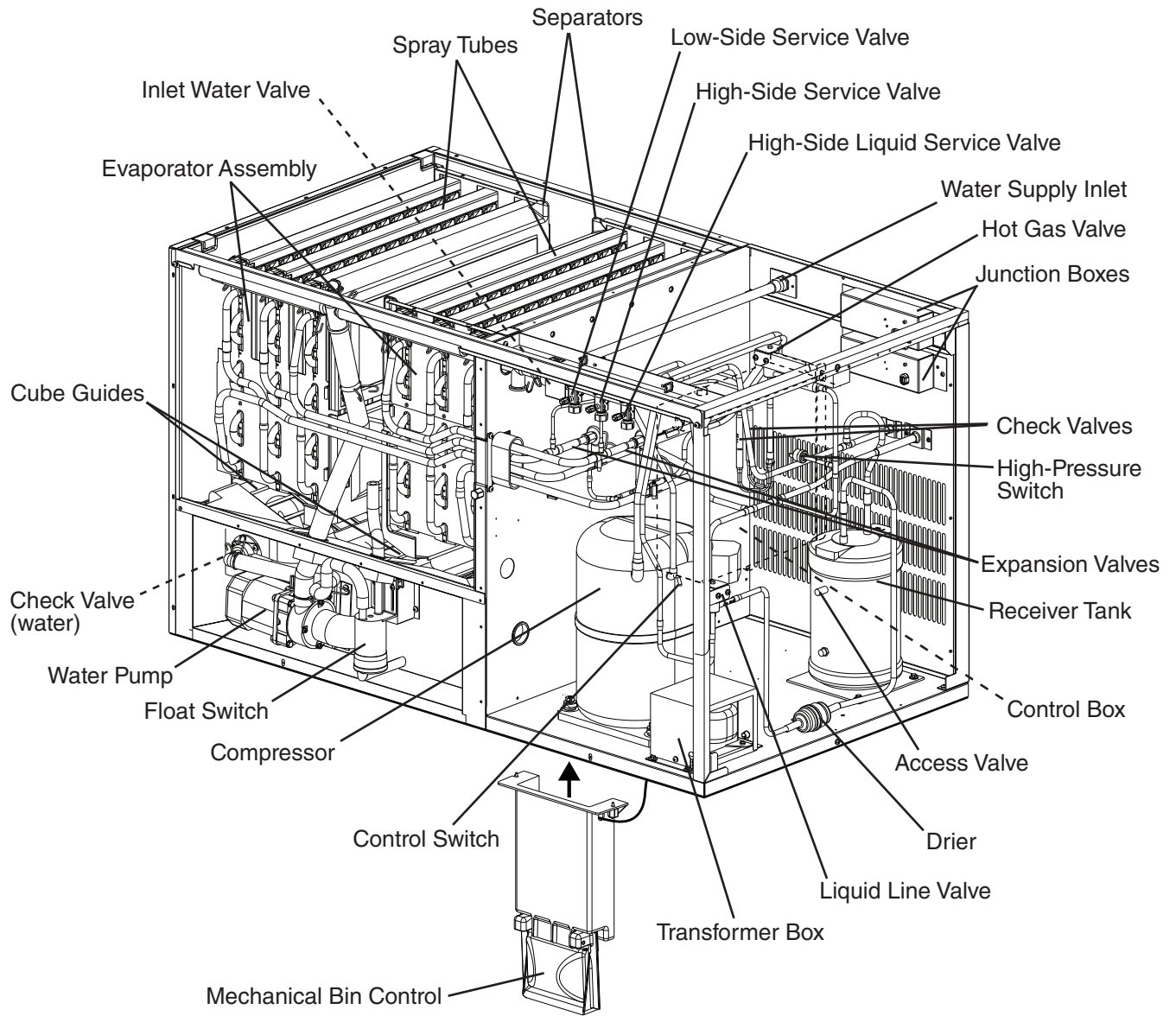

## B. Sequence of Operation

### IMPORTANT

KM-1301SAH-E utilizes a thermostatic bin control. For KM-1301SAH-E operation, the K4 jumper (4A4883G01) must be in place on the control board RED K4 connector or the unit will not operate.

#### 1. Sequence Cycles and Shutdown

The steps in the sequence are as outlined below. When power is supplied, CB red "POWER OK" LED and green "BC CLOSED" LED come on. If red "POWER OK" LED is off on KM-1301SAH-E, clear ice away from the thermostatic bin control bulb in the storage bin area. If yellow "BC OPEN" LED is on, the unit will not start. In this case check that CB has the K4 jumper in place on CB RED K4 connector (KM-1301SAH-E) or clear ice away from the mechanical bin control actuator paddle in the storage bin area (KM-1301SWH-E, KM-1301SRH-E). There is a 5-second delay before startup. Note that the order of the component LEDs from the outer edge of CB is 1, 4, 3, 2.

##### a) 1-Minute Fill Cycle

**LED 4 is on.** WV and X2 relay (auxiliary code T-0, U-0), X11 relay (auxiliary code U-1 and later) energize and the 1-minute fill cycle begins. After 1 minute, CB checks for a closed F/S. If F/S is closed, the harvest cycle begins. If not, WV remains energized through additional 1-minute fill cycles until water fills the tank and closes F/S. This serves as a low water safety to protect PM.

##### b) Initial Harvest Cycle

**LEDs 1, 4, and 2 are on.** WV and X2 relay (auxiliary code T-0, U-0), X11 relay (auxiliary code U-1 and later) remain energized, HGV, X1 relay (auxiliary code T-0, U-0), X10 relay (auxiliary code U-1 and later), Comp, and FMR energize. CB monitors the warming of the evaporator via the thermistor located on the suction line. When the thermistor reaches 48°F (9°C), CB reads a 3.9 kΩ signal from the thermistor and turns harvest termination over to the harvest timer (S4 dip switch 1 & 2). The harvest timer has settings of 60, 90, 120, and 180 seconds. For details, see "II.C.2.b) Harvest Timer (S4 dip switch 1 & 2)." WV is energized during harvest for a maximum of 6 minutes or the length of harvest minus 0 or 50 seconds (harvest pump timer (S4 dip switch 7)), whichever is shorter. **CAUTION! Do not adjust S4 dip switch 7 out of the factory default position on this model. Adjustment outside of the factory default position may result in damage to the icemaker.** For details, see "II.C.2.e) Harvest Pump Timer (S4 dip switch 7)." LED 4 goes off when WV and X2 relay (auxiliary code T-0, U-0), X11 relay (auxiliary code U-1 and later) de-energize. LED 3 comes on and PM energizes and runs for the last 0 or 50 seconds of harvest depending on S4 dip switch 7 setting. This circulates water over the evaporator for the last 0 or 50 seconds of harvest. PM is energized through the #5 pin (DBu wire) on the CB K1 ten-pin connector and the X1 relay (auxiliary code T-0, U-0), X10 relay (auxiliary code U-1 and later). When the harvest timer terminates, the harvest cycle is complete. CB checks the position of F/S and proceeds to the freeze cycle if it is closed or calls for a 1-minute fill cycle if it is open. The minimum total time allowed by CB for a complete harvest cycle is 2 minutes.

**c) Freeze Cycle**

**LED 1 is on.** Comp and FMR remain energized, PM energizes or remains energized depending on harvest pump timer (S4 dip switch 7) setting. FM and LLV energize. HGV and X1 relay (auxiliary code T-0, U-0), X10 relay (auxiliary code U-1 and later) de-energize. For the first 5 minutes, CB will not accept a signal from F/S. This minimum 5-minute freeze time is short cycle protection for Comp. At the end of 5 minutes, F/S assumes control. As ice builds on the evaporator, the water level in the tank lowers. The freeze cycle continues until F/S opens and terminates the cycle. There is a 15 second delay before CB acknowledges an open F/S.

**d) Pump-Out Cycle**

**LEDs 1, 3, and 2 are on.** LED 4 is on when S4 dip switch 3 & 4 are set to 3 off and 4 on. For details, see "II.C.2.c) Pump-Out Timer (S4 dip switch 3 & 4)." **CAUTION! Do not adjust S4 dip switch 3 & 4 to 3 off and 4 on. Adjustment to this position on this model prevents the pump motor from rotating in the pump-out direction.** Comp and FMR remain energized, HGV energizes, WV energizes if S4 dip switch 3 off and 4 on. LLV and FM de-energize. PM stops for 2 seconds then reverses, taking water from the bottom of the tank and forcing pressure against the check valve seat allowing water to go through the check valve and down the drain. At the same time, water flows through the small tube to power flush F/S. When the pump-out timer terminates, the pump-out is complete.

The first pump-out occurs after the 11th freeze cycle, then every 10th cycle thereafter. The pump-out frequency control is factory set, and generally no adjustment is required. However, where water quality is bad and the icemaker needs a pump-out more often, the pump-out frequency can be adjusted. The pump-out frequency control (S4 dip switch 5 & 6) can be set to have a pump-out occur every cycle, or every 2, 5, or 10 cycles. Timing of the first pump-out is dependent on S4 dip switch 5 & 6 settings. See the table below.

S4 Dip Switch Setting		Pump-Out Frequency	1st Pump-Out
No. 5	No. 6		
OFF	OFF	Every cycle	After 2nd freeze cycle
ON	OFF	Every 2 cycles	After 3rd freeze cycle
OFF	ON	Every 5 cycles	After 6th freeze cycle
ON	ON	Every 10 cycles	After 11th freeze cycle

**e) Harvest Cycle**

Same as the initial harvest cycle. See "II.B.1.b) Initial Harvest Cycle."

Note: Unit continues to cycle until BC is satisfied or power is turned off. The unit always restarts at the 1-minute fill cycle.

**f) Shutdown**

*(1) Thermostatic Bin Control (KM-1301SAH-E)*

When ice contacts the thermostatic BC bulb (BC open), thermostatic BC shuts down the unit within 10 seconds. Thermostatic BC is factory set, and generally no adjustment is required. However, adjustment may be needed in some conditions, particularly at higher altitude locations.

(2) *Mechanical Bin Control (KM-1301SWH-E, KM-1301SRH-E)*

When mechanical BC is activated (BC open), the yellow "BC OPEN" LED comes on. The unit then shuts down as outlined in the table below.

<b>Cycle at Mechanical Bin Control Activation</b>	<b>Shutdown</b>
Fill Cycle	15 seconds after activation.
Harvest Cycle	At the end of the harvest cycle, or up to 15 seconds into the freeze cycle if activated at the end of the harvest cycle.
Freeze Cycle	15 seconds after activation if activated at least 15 seconds before the 5-minute short cycle protection timer terminates. Otherwise, at the end of the next harvest cycle.

Legend: **BC**–bin control; **CB**–control board; **Comp**–compressor; **FM**–fan motor; **FMR**–fan motor-remote; **F/S**–float switch; **HGV**–hot gas valve; **LLV**–liquid line valve; **PM**–pump motor; **WV**–inlet water valve



## 2. Sequence Flow Chart

### "G" Control Board Sequence Flow Chart KM-1301SAH-E, KM-1301SWH-E, KM-1301SRH-E

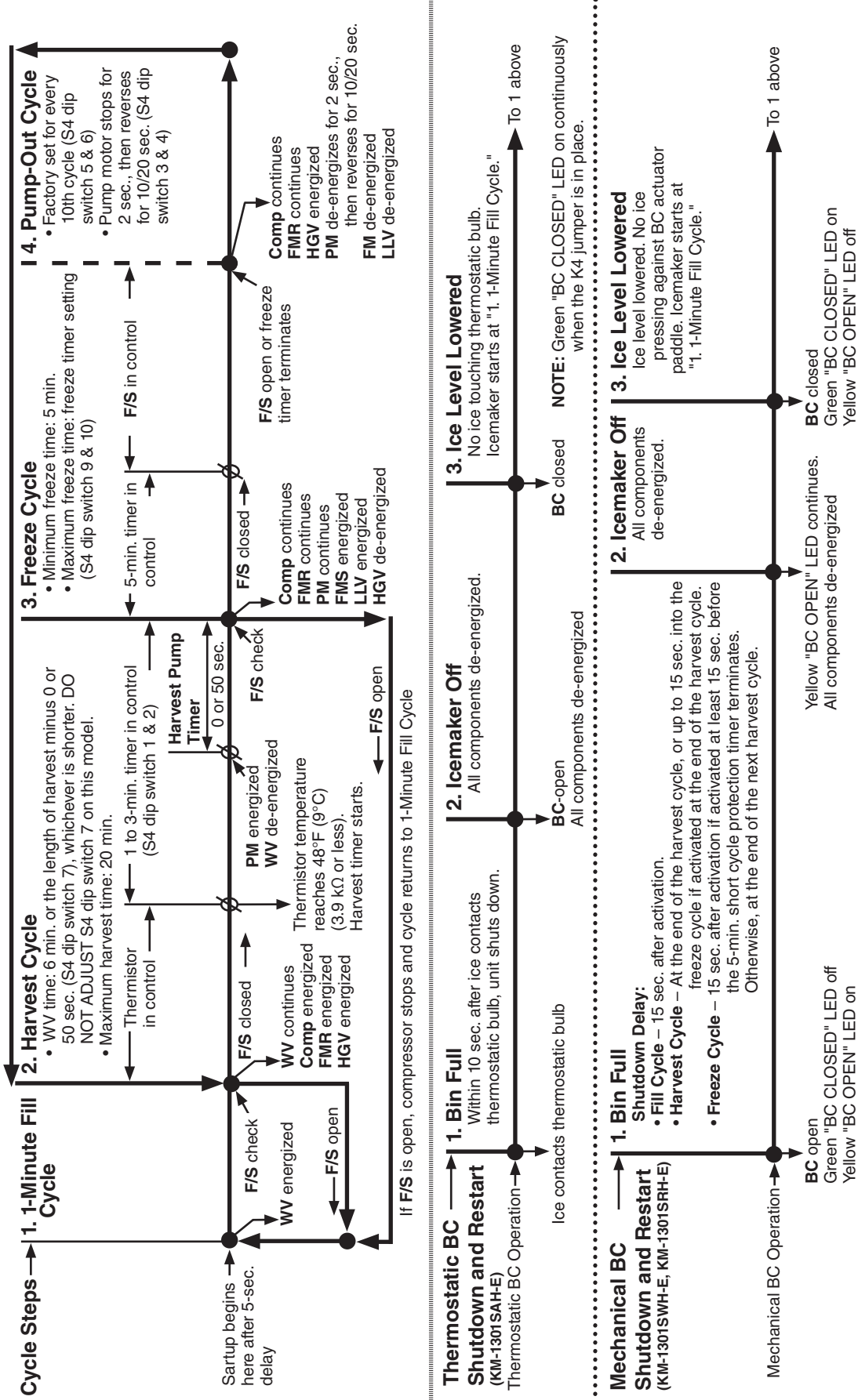

**Legend:**  
 BC—bin control  
 Comp—compressor  
 FM—fan motor  
 FMS—fan motor-remote  
 F/S—float switch  
 HGV—hot gas valve  
 LLV—liquid line valve  
 PM—pump motor  
 WV—inlet water valve

**Components Energized when the Control Switch is in the "WASH" Position**  
 The "WASH" position on the control switch is used when cleaning and sanitizing the unit. When in the "WASH" position, power is supplied to the pump motor. This allows cleaner and sanitizer to flow over the outside of the evaporator plate assembly.

## C. Control Board

- A Hoshizaki exclusive solid-state control board is employed in Hoshizaki Stackable Crescent Cubers.
- All models are pretested and factory set.

### CAUTION

1. The control board is fragile; handle very carefully.
2. The control board contains integrated circuits, which are susceptible to failure due to static discharge. It is especially important to touch the metal part of the unit before handling or replacing the control board.
3. Do not touch the electronic devices on the control board or the back of the control board.
4. Do not change wiring and connections. Do not misconnect K3, K4, and K5, because the same connector is used for the thermistor, jumper (KM-1301SAH-E) or mechanical bin control (KM-1301SWH-E, KM-1301SRH-E), and float switch. KM-1301SAH-E utilizes a thermostatic bin control. For KM-1301SAH-E operation, the K4 jumper (4A4883G01) must be in place on the control board RED K4 connector.
5. Always replace the whole control board assembly if it goes bad.
6. Do not short out power supply to test for voltage.

# 1. Control Board Layout

## "G" Control Board

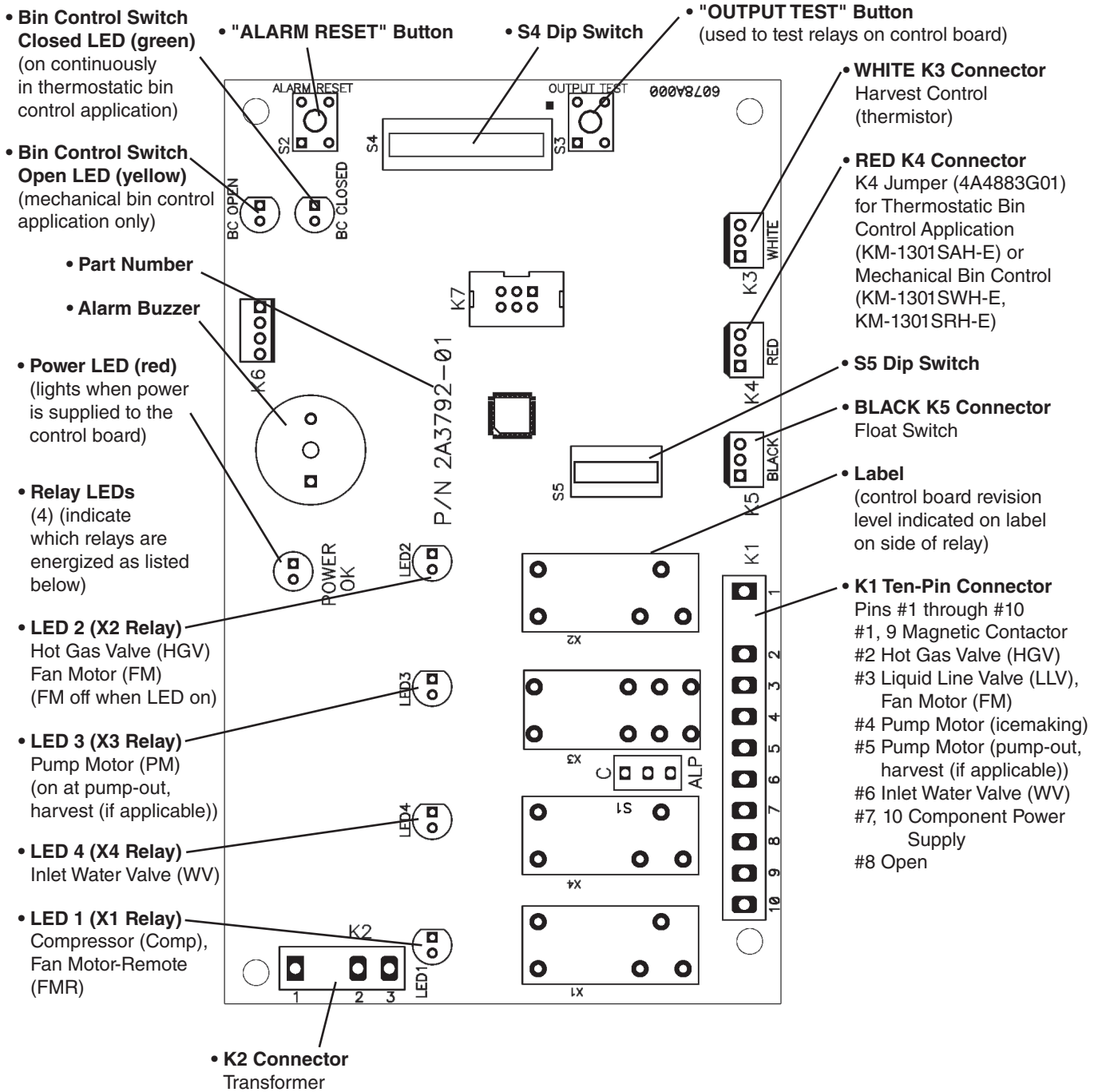

"G" Control Board	
Part Number	2A3792-01

**a) LED Lights and Audible Alarm Safeties**

At startup, a 5-second delay occurs while the control board conducts an internal timer check. A beep occurs when the control switch is moved to the "ICE" position.

The red LED indicates proper control voltage and remains on unless a control voltage problem occurs. The green LEDs 1 through 4 energize and sequence from initial startup as listed in the table below. Note that the order of the LEDs from the outer edge of the control board is 1, 4, 3, 2. For details, see "II.B. Sequence of Operation."

Sequence Step	LED	Energized Components	Time LEDs are On		
			Min.	Max.	Avg.
1-Minute Fill Cycle	4	WV			1 minute
Harvest Cycle	1, 4, 2	Comp, FMR, WV, HGV	2 minutes	20 minutes	3 to 5 minutes
Harvest Pump Timer	1, 3, 2	Comp, FMR, PM, HGV	0 seconds	50 seconds	harvest pump timer setting
Freeze Cycle	1	Comp, FM/FMR, PM, LLV	5 minutes	freeze timer setting	30 to 35 minutes
Pump-Out Cycle	1, 4*, 3, 2	Comp, FMR, WV*, PM, HGV	10 seconds	20 seconds	*pump-out timer setting

The built-in safeties shut down the unit and have alarms as listed below.

No. of Beeps (every 3 sec.)	Type of Alarm	Notes
1	High Evaporator Temp. (temperature > 127°F (53°C))	Check for harvest problem (stuck HGV or relay), hot water entering unit, stuck HM, or shorted thermistor.
2	Harvest Backup Timer (harvest > 20 min. for two cycles in a row)	Check for open thermistor, HGV not opening, TXV or LLV leaking by, low charge, inefficient Comp., or WRV leaking by.
3	Freeze Timer (freeze > freeze timer setting for two cycles in a row) Timer is factory set using S4 dip switch 9 & 10	Check for F/S stuck closed (up), WV leaking by, HGV leaking by, PM not pumping, TXV not feeding properly, LLV not opening, low charge, HM not bypassing, or inefficient Comp.
To reset the above safeties, press the "ALARM RESET" button with the power supply on.		
6	Low Voltage (92Vac±5% or less)	Red LED turns off if voltage protection operates. The control voltage safeties automatically reset when voltage is corrected.
7	High Voltage (147Vac±5% or more)	

Legend: **Comp**—compressor; **FM**—fan motor; **FMR**—fan motor-remote; **F/S**—float switch; **HGV**—hot gas valve; **HM**—headmaster (C.P.R.); **LLV**—liquid line valve; **PM**—pump motor; **TXV**—thermostatic expansion valve; **WRV**—water regulating valve; **WV**—inlet water valve

## 2. Controls and Adjustments

### CAUTION

Dip switches are factory set. Failure to maintain factory settings may adversely affect performance and warranty coverage. For more information, contact Hoshizaki Technical Support at 1-800-233-1940.

#### a) Default Dip Switch Settings

The dip switches are factory set to the following positions:

S4 Dip Switch										
S4 Dip Switch No.	1	2	3	4	5	6	7	8	9	10
KM-1301SAH-E	OFF	OFF	ON	ON	ON	ON	ON	OFF	ON	ON
KM-1301SWH-E	OFF	OFF	ON	ON	ON	ON	ON	OFF	ON	ON
KM-1301SRH-E	ON	OFF	ON	ON	ON	ON	ON	OFF	ON	ON

S5 Dip Switch (Do Not Adjust)					
S5 Dip Switch No.	1	2	3	4	5
KM-1301SAH-E	OFF	OFF	OFF	OFF	OFF
KM-1301SWH-E	OFF	OFF	OFF	OFF	OFF
KM-1301SRH-E	OFF	OFF	OFF	OFF	OFF

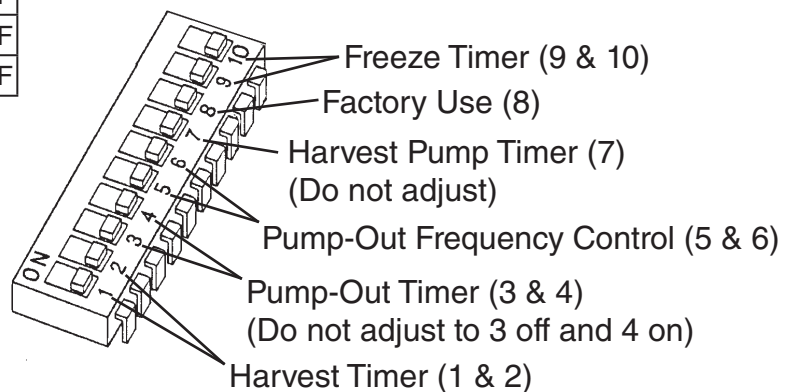

#### b) Harvest Timer (S4 dip switch 1 & 2)

The harvest timer starts when the thermistor reads 48°F (9°C) at the evaporator outlet and the control board reads the thermistor's 3.9 kΩ signal. The harvest timer is factory set, and generally no adjustment is required. However, a setting longer than the factory setting may be advised in cases where the flush provided at harvest needs to be prolonged for extra cleaning. Before changing this setting, contact Hoshizaki Technical Support at 1-800-233-1940 for recommendations. Keep in mind that setting the harvest timer to a longer setting decreases 24-hour production.

Note that the pump-out timer (S4 dip switch 3 & 4) acts in place of the harvest timer during cycles with a pump-out. For details, see "II.C.2.c) Pump-Out Timer (S4 dip switch 3 & 4)."

S4 Dip Switch Setting		Time (seconds)
No. 1	No. 2	
OFF	OFF	60
ON	OFF	90
OFF	ON	120
ON	ON	180

**c) Pump-Out Timer (S4 dip switch 3 & 4)**

**CAUTION**

Do not adjust S4 dip switch 3 off and S4 dip switch 4 on for this model. Otherwise, pump motor does not rotate in the pump-out direction.

When a pump-out is called for, the pump motor stops after the preceding freeze cycle. The pump motor restarts 2 seconds later in the reverse direction, taking water from the bottom of the tank and forcing pressure against the check valve seat allowing water to go through the check valve and down the drain. At the same time, water flows through the small tube to power flush the float switch. The pump motor drains the water tank for the time determined by the pump-out timer. The pump-out timer also acts in place of the harvest timer during cycles with a pump-out. The pump-out timer is factory set, and generally no adjustment is required. The pump-out timer control can be set to pump-out for 10 or 20 seconds.

S4 Dip Switch Setting		Time (seconds)		Inlet Water Valve
No. 3	No. 4	T1	T2	
OFF	OFF	10	150	closed
ON	OFF	10	180	closed
OFF	ON	10	120	open
ON	ON	20	180	closed

T1: Time to drain the water tank

T2: Harvest timer at pump-out

**d) Pump-Out Frequency Control (S4 dip switch 5 & 6)**

The pump-out frequency control is factory set to drain the water tank every 10 cycles, and generally no adjustment is required. However, where water quality is bad and the icemaker needs a pump-out more often, the pump-out frequency can be adjusted. The pump-out frequency control can be set to have a pump-out occur every cycle, or every 2, 5, or 10 cycles.

Timing of the first pump-out is dependent on S4 dip switch 5 & 6 settings. The first pump-out is factory set to occur after the 11th freeze cycle. See the table below.

S4 Dip Switch Setting		Pump-Out Frequency	1st Pump-Out
No. 5	No. 6		
OFF	OFF	Every cycle	After 2nd freeze cycle
ON	OFF	Every 2 cycles	After 3rd freeze cycle
OFF	ON	Every 5 cycles	After 6th freeze cycle
ON	ON	Every 10 cycles	After 11th freeze cycle

**e) Harvest Pump Timer (S4 dip switch 7)**

**CAUTION**

Factory set for proper operation. Do not adjust. Adjustment outside of the factory default setting may result in damage to the icemaker.

Depending on the harvest pump timer setting, the pump motor energizes and runs the last 0 or 50 seconds of harvest. When the pump is on, water circulates over the evaporator. The water valve is open during harvest for a maximum of 6 minutes or the length of harvest minus 0 or 50 seconds (determined by the harvest pump timer setting), whichever is shorter.

When S4 dip switch 7 is on, the pump motor is energized through the #5 pin (DBu wire) on the control board K1 ten-pin connector and the X1 relay (auxiliary code T-0, U-0), X10 relay (auxiliary code U-1 and later). The #5 pin (DBu wire) is used in most applications to reverse the pump motor or energize the drain valve in pump-out cycles. In this application, it is used for the pump-out cycle (reverse rotation) as well as the harvest pump timer (freeze rotation). Therefore, the harvest pump timer relays are needed to control the pump motor direction during the pump-out and harvest cycles. See "III.B. Wiring Diagrams."

S4 Dip Switch Setting		Pump Motor Time (seconds)
No. 7		
	ON	50
	OFF	0

**f) Factory Use (S4 dip switch 8)**

Factory set for proper operation. Do not adjust. This must be left in the factory default position.

**g) Freeze Timer (S4 dip switch 9 & 10)**

**CAUTION**

Adjust to proper specification, or the unit may not operate correctly.

The freeze timer setting determines the maximum allowed freeze time to prevent possible freeze-up issues. Upon termination of the freeze timer, the control board initiates the harvest cycle. After 2 consecutive freeze timer terminations, the control board shuts down the icemaker. In this case, see "IV.G.3. Low Ice Production" for possible solutions. The freeze timer is factory set, and generally no adjustment is required. Before changing this setting, contact Hoshizaki Technical Support at 1-800-233-1940 for recommendations.

S4 Dip Switch Setting		Time (minutes)
No. 9	No. 10	
OFF	OFF	60
OFF	ON	50
ON	OFF	70
ON	ON	60

***h) Float Switch Control (S5 dip switch 1)***

**CAUTION**

Do not adjust. This must be left in the factory default position or the unit will not operate correctly.

Factory set. S5 dip switch 1 allows for single or double float switch applications. The KM-1301SAH-E, KM1301SWH-E, and KM-1301SRH-E use a single float switch.

***i) Refill Counter (S5 dip switch 2 through 5)***

**CAUTION**

Do not adjust. These must be left in the factory default position or the unit will not operate correctly.

Factory set. S5 dip switch 2 through 5 allows for refills during the freeze cycle. The KM-1301SAH-E, KM1301SWH-E, and KM-1301SRH-E do not refill.

**D. Control Switch**

The control switch has three positions: "OFF" for power off, "ICE" for icemaking, and "WASH" to activate the water pump when cleaning and sanitizing.



### III. Technical Information

#### A. Water Circuit and Refrigeration Circuit

##### 1. KM-1301SAH-E (air-cooled)

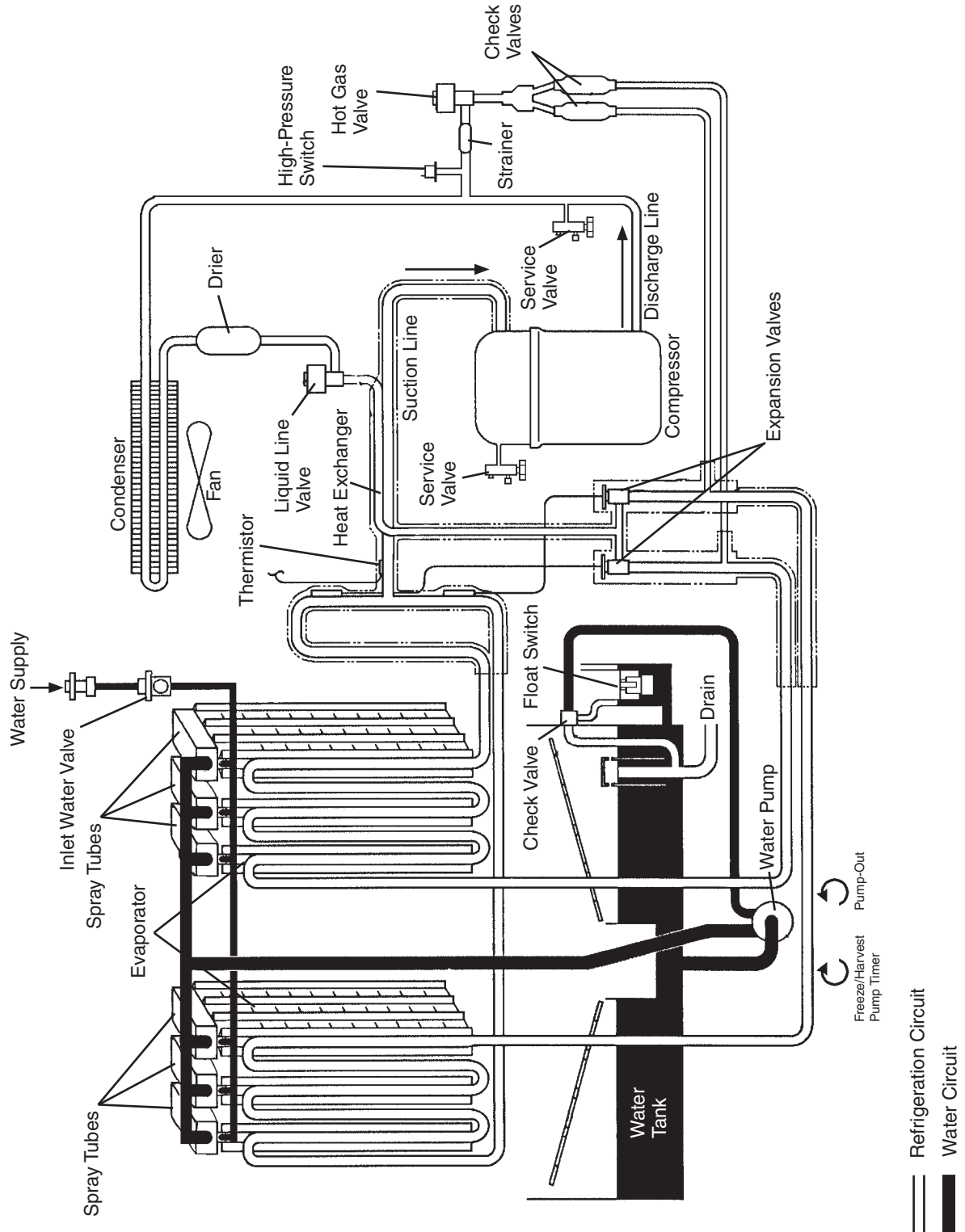

## 2. KM-1301SWH-E (water-cooled)

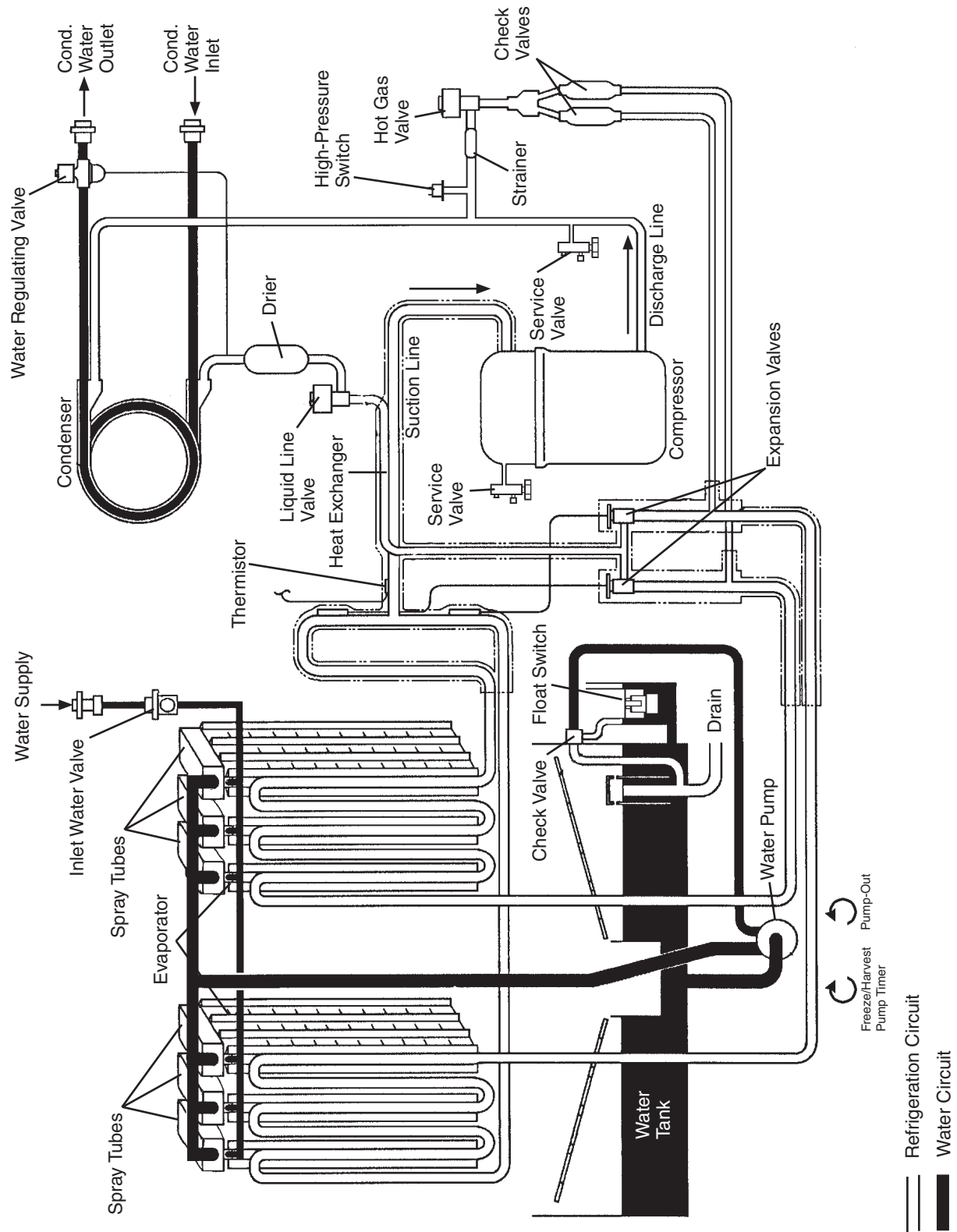

### 3. KM-1301SRH-E (remote air-cooled)

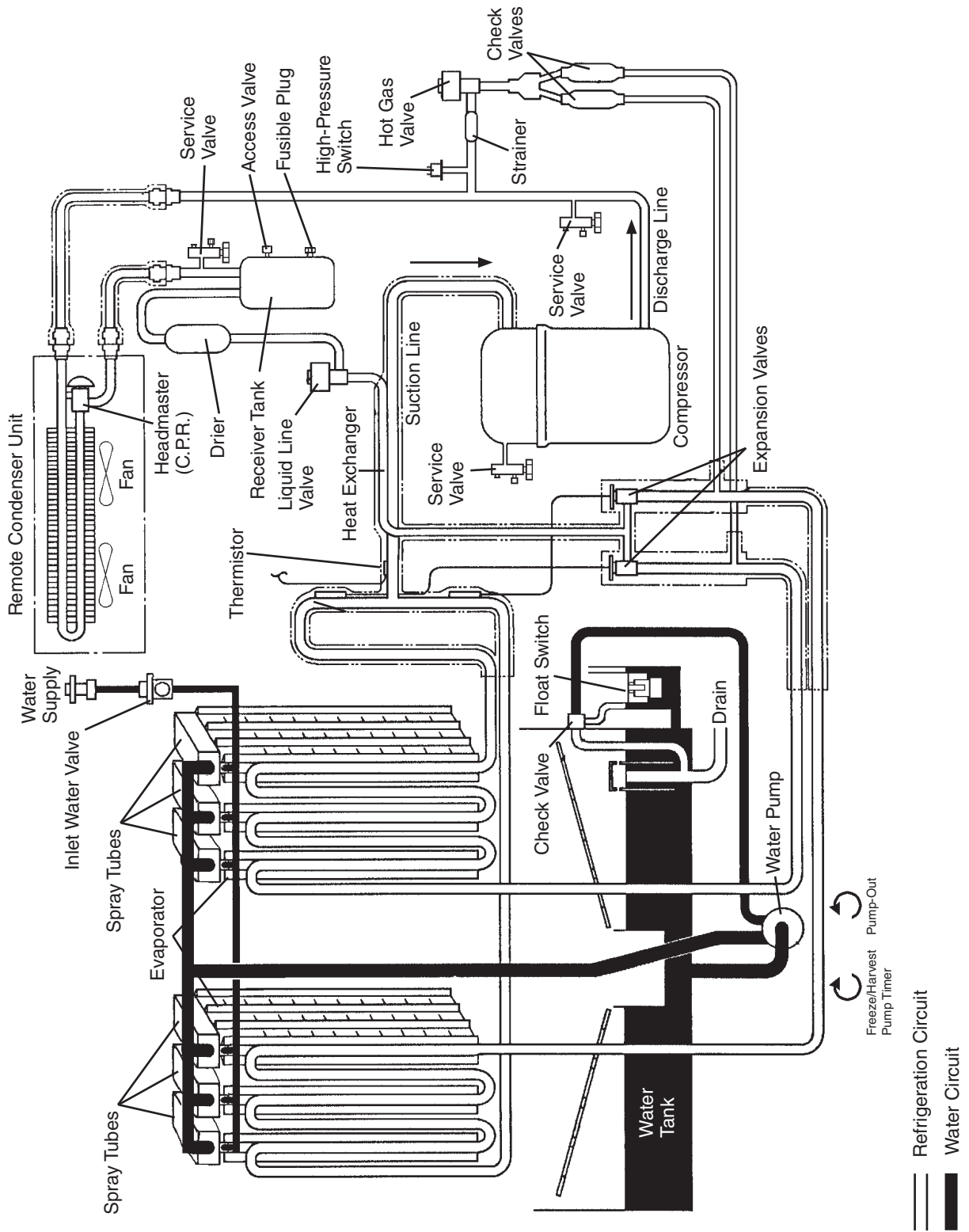

# B. Wiring Diagrams

## 1. Auxiliary Code T-0, U-0

### a) KM-1301SAH-E (air-cooled)

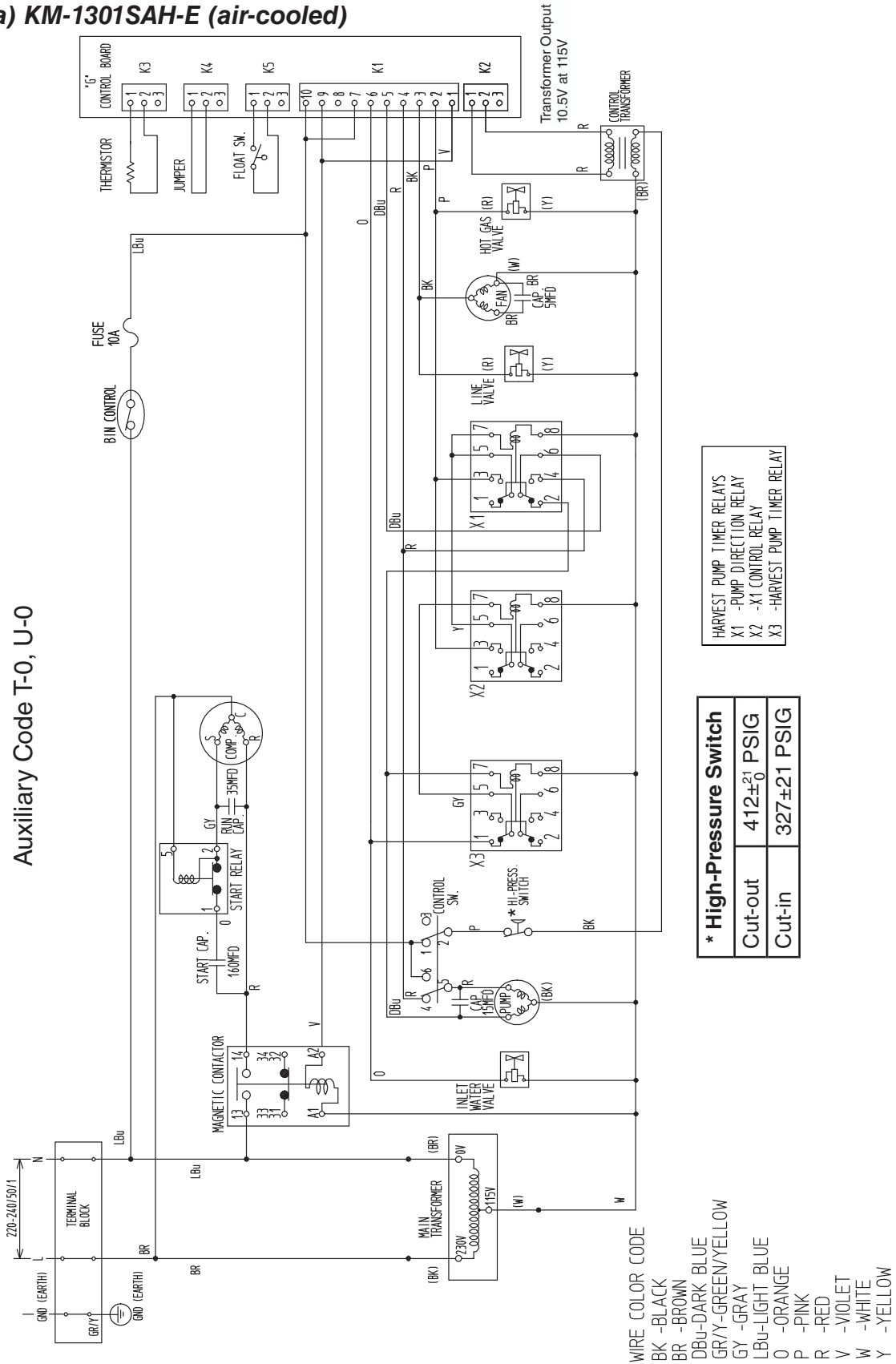

## 2. Auxiliary Code U-1 and Later

### a) KM-1301SAH-E (air-cooled)

#### Auxiliary Code U-1 and Later

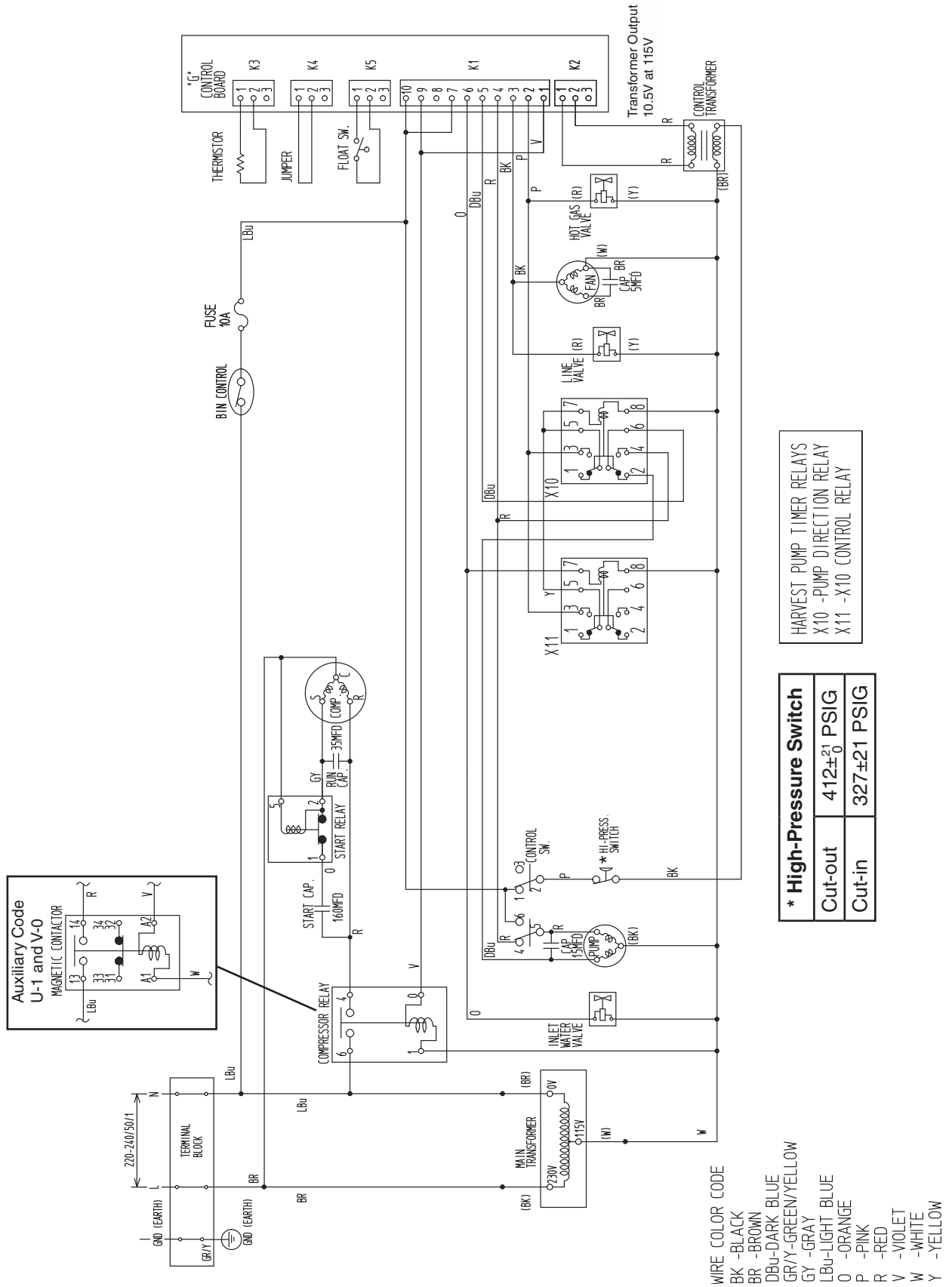

**b) KM-1301SWH-E (water-cooled)**

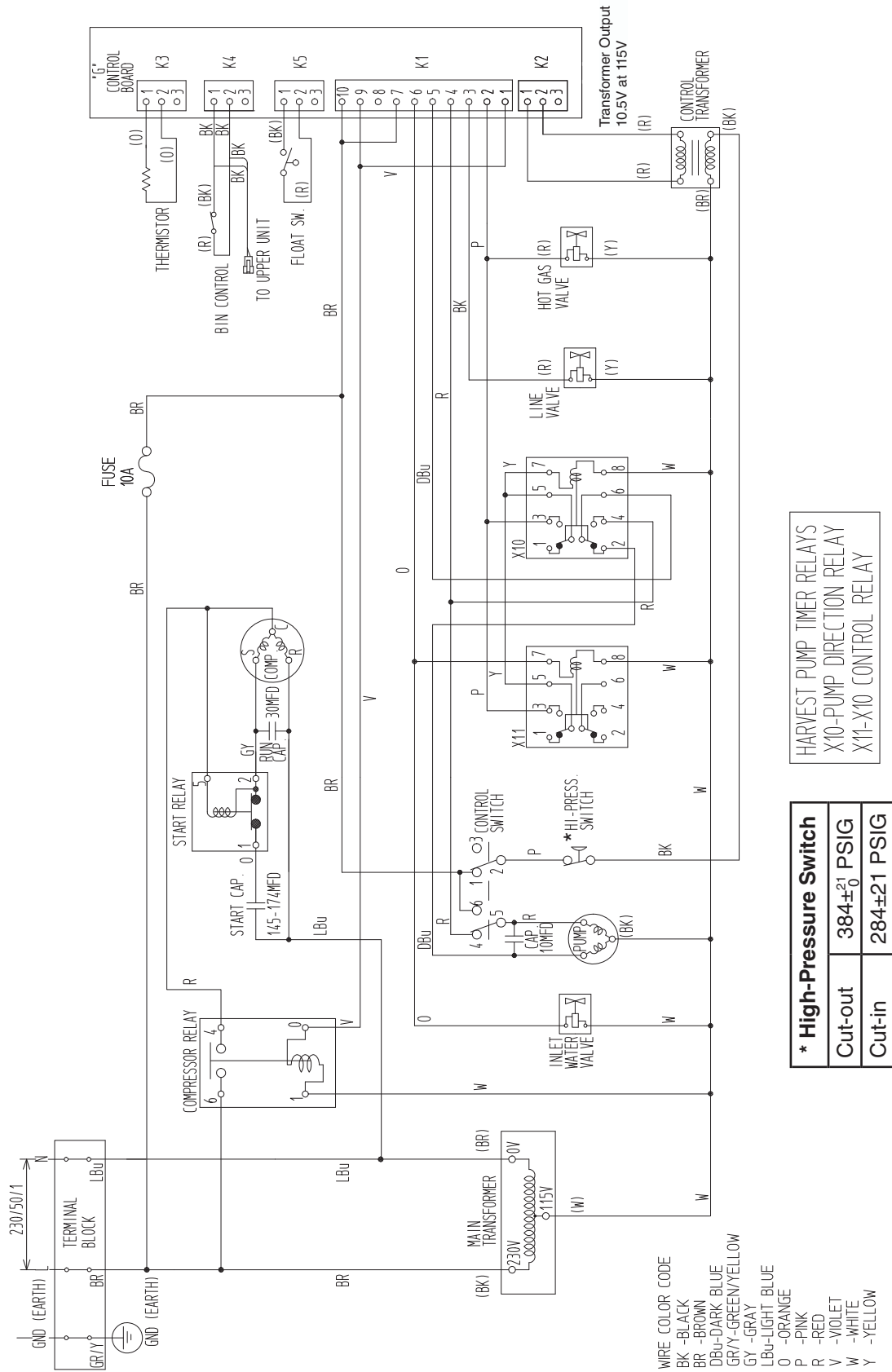

HARVEST PUMP TIMER RELAYS  
 X10-PUMP DIRECTION RELAY  
 X11-X10 CONTROL RELAY

<b>* High-Pressure Switch</b>	
Cut-out	384±21 PSIG
Cut-in	284±21 PSIG

c) KM-1301SRH-E (remote air-cooled)

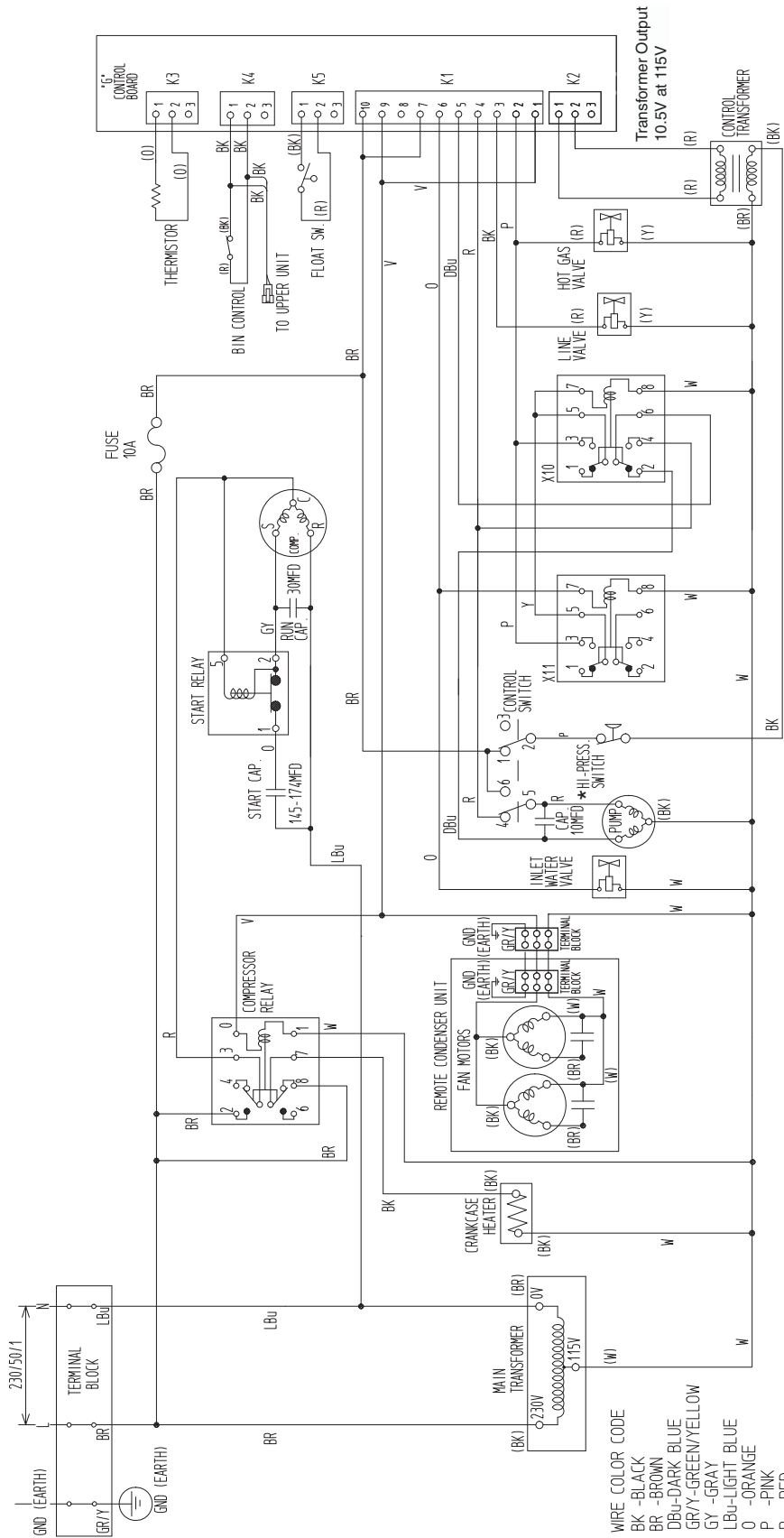

HARVEST PUMP TIMER RELAYS  
X10-PUMP DIRECTION RELAY  
X11-X10 CONTROL RELAY

<b>* High-Pressure Switch</b>	
Cut-out	412±21 PSIG
Cut-in	327±21 PSIG

WIRE COLOR CODE  
BK - BLACK  
BR - BROWN  
DBU - DARK BLUE  
GY - GREEN/YELLOW  
LBU - LIGHT BLUE  
O - ORANGE  
P - PINK  
R - RED  
V - VIOLET  
W - WHITE  
Y - YELLOW

## C. Performance Data

### 1. KM-1301SAH-E (air-cooled)

APPROXIMATE ICE PRODUCTION PER 24 HR.	AMBIENT TEMP. (°F/°C)	WATER TEMP. (°F/°C)					
		50/10		70/21		90/32	
	70/21	<b>1114</b>	<u>505</u>	1082	<u>491</u>	992	<u>450</u>
	80/27	1089	<u>494</u>	1039	<u>471</u>	924	<u>419</u>
	90/32	1082	<u>491</u>	<b>1004</b>	<u>455</u>	897	<u>407</u>
lbs./day <u>kg./day</u>	100/38	1048	<u>475</u>	979	<u>444</u>	799	<u>362</u>
APPROXIMATE ELECTRIC CONSUMPTION	70/21	<b>1900</b>		1964		2009	
	80/27	1949		2049		2069	
	90/32	1964		<b>2120</b>		2151	
	watts	1958		2127		2180	
APPROXIMATE WATER CONSUMPTION PER 24 HR.	70/21	<b>537</b>	<u>2.03</u>	426	<u>1.61</u>	377	<u>1.43</u>
	80/27	452	<u>1.71</u>	279	<u>1.06</u>	288	<u>1.09</u>
	90/32	426	<u>1.61</u>	<b>157</b>	<u>0.59</u>	140	<u>0.53</u>
	gal./day <u>m<sup>3</sup>/day</u>	100/38	302	<u>1.14</u>	153	<u>0.58</u>	125
FREEZING CYCLE TIME	70/21	<b>34</b>		35		39	
	80/27	35		38		43	
	90/32	35		<b>40</b>		44	
	min.	100/38		37		41	
HARVEST CYCLE TIME	70/21	<b>4.8</b>		4.0		3.7	
	80/27	4.2		2.9		3.2	
	90/32	4.0		<b>2.1</b>		2.1	
	min.	100/38		3.1		2.1	
HEAD PRESSURE	70/21	<b>275</b>	<u>19.3</u>	293	<u>20.6</u>	316	<u>22.2</u>
	80/27	289	<u>20.3</u>	318	<u>22.3</u>	338	<u>23.8</u>
	90/32	293	<u>20.6</u>	<b>338</b>	<u>23.8</u>	360	<u>25.3</u>
	PSIG <u>kg/cm<sup>2</sup>G</u>	100/38	297	<u>20.9</u>	343	<u>24.1</u>	380
SUCTION PRESSURE	70/21	<b>57</b>	<u>4.0</u>	58	<u>4.1</u>	61	<u>4.3</u>
	80/27	58	<u>4.1</u>	59	<u>4.2</u>	64	<u>4.5</u>
	90/32	58	<u>4.1</u>	<b>60</b>	<u>4.2</u>	64	<u>4.5</u>
	PSIG <u>kg/cm<sup>2</sup>G</u>	100/38	59	<u>4.2</u>	61	<u>4.3</u>	68

TOTAL HEAT OF REJECTION FROM CONDENSER

19,000 BTU/h [AT 90°F (32°C) / WT 70°F (21°C)]

**Note:**

1. Pressure data is recorded at 5 minutes into freezing cycle. The data not in **bold** should be used for reference only.
2. We reserve the right to make changes in specifications and design without prior notice.



## 2. KM-1301SWH-E (water-cooled)

APPROXIMATE ICE PRODUCTION PER 24 HR.	AMBIENT TEMP. (°F/°C)	WATER TEMP. (°F/°C)					
		50/10		70/21		90/32	
	70/21	<b>1330</b>	<u>603</u>	1304	<u>591</u>	1239	<u>562</u>
	80/27	1310	<u>594</u>	1269	<u>576</u>	1189	<u>539</u>
	90/32	1304	<u>591</u>	<b>1240</b>	<u>562</u>	1165	<u>528</u>
lbs./day <u>kg./day</u>	100/38	1281	<u>581</u>	1222	<u>554</u>	1096	<u>497</u>
APPROXIMATE ELECTRIC CONSUMPTION	70/21	<b>1780</b>		1780		1799	
	80/27	1780		1780		1810	
	90/32	1780		<b>1780</b>		1806	
watts	100/38	1790		1786		1830	
APPROXIMATE WATER CONSUMPTION PER 24 HR.	70/21	<b>1335</b>	<u>5.05</u>	1425	<u>5.40</u>	1971	<u>7.46</u>
	80/27	1404	<u>5.31</u>	1544	<u>5.85</u>	2324	<u>8.80</u>
	90/32	1425	<u>5.40</u>	<b>1643</b>	<u>6.22</u>	2335	<u>8.84</u>
gal./day <u>m<sup>3</sup>/day</u>	100/38	1741	<u>6.59</u>	1805	<u>6.83</u>	2971	<u>11.25</u>
FREEZING CYCLE TIME	70/21	<b>31</b>		32		34	
	80/27	32		33		35	
	90/32	32		<b>34</b>		36	
min.	100/38	33		34		38	
HARVEST CYCLE TIME	70/21	<b>4.2</b>		3.7		3.4	
	80/27	3.8		3.0		2.9	
	90/32	3.7		<b>2.4</b>		2.2	
min.	100/38	3.1		2.4		2.1	
HEAD PRESSURE	70/21	<b>238</b>	<u>16.7</u>	239	<u>16.8</u>	249	<u>17.5</u>
	80/27	239	<u>16.8</u>	240	<u>16.9</u>	256	<u>18.0</u>
	90/32	239	<u>16.8</u>	<b>241</b>	<u>16.9</u>	255	<u>17.9</u>
PSIG <u>kg/cm<sup>2</sup>G</u>	100/38	244	<u>17.2</u>	244	<u>17.2</u>	267	<u>18.8</u>
SUCTION PRESSURE	70/21	<b>50</b>	<u>3.5</u>	51	<u>3.6</u>	52	<u>3.6</u>
	80/27	50	<u>3.5</u>	51	<u>3.6</u>	52	<u>3.7</u>
	90/32	51	<u>3.6</u>	<b>52</b>	<u>3.7</u>	53	<u>3.7</u>
PSIG <u>kg/cm<sup>2</sup>G</u>	100/38	51	<u>3.6</u>	52	<u>3.7</u>	54	<u>3.8</u>

TOTAL HEAT OF REJECTION FROM CONDENSER	19,382 BTU/h [AT 90°F (32°C) / WT 70°F (21°C)]
TOTAL HEAT OF REJECTION FROM COMPRESSOR	2,600 BTU/h [AT 90°F (32°C) / WT 70°F (21°C)]
WATER FLOW FOR CONDENSER	117 gal./h [AT 100°F (38°C) / WT 90°F (32°C)]
PRESSURE DROP OF COOLING WATER LINE	less than 10 PSIG

Note:

1. Pressure data is recorded at 5 minutes into freezing cycle. The data not in **bold** should be used for reference only.
2. We reserve the right to make changes in specifications and design without prior notice.

### 3. KM-1301SRH-E (remote air-cooled)

APPROXIMATE ICE PRODUCTION PER 24 HR.	AMBIENT TEMP. (°F/°C)	WATER TEMP. (°F/°C)					
		50/10		70/21		90/32	
	70/21	<b>1270</b>	<u>576</u>	1233	<u>559</u>	1160	<u>526</u>
	80/27	1241	<u>563</u>	1183	<u>537</u>	1100	<u>499</u>
	90/32	1233	<u>559</u>	<b>1142</b>	<u>518</u>	1062	<u>482</u>
lbs./day <u>kg./day</u>	100/38	1211	<u>549</u>	1123	<u>509</u>	988	<u>448</u>
APPROXIMATE ELECTRIC CONSUMPTION	70/21	<b>1950</b>		1985		2028	
	80/27	1977		2031		2071	
	90/32	1985		<b>2070</b>		2112	
watts	100/38	1992		2080		2150	
APPROXIMATE WATER CONSUMPTION PER 24 HR.	70/21	<b>544</b>	<u>2.06</u>	451	<u>1.71</u>	396	<u>1.50</u>
	80/27	473	<u>1.79</u>	330	<u>1.25</u>	314	<u>1.19</u>
	90/32	451	<u>1.71</u>	<b>228</b>	<u>0.86</u>	194	<u>0.74</u>
gal./day <u>m<sup>3</sup>/day</u>	100/38	342	<u>1.30</u>	220	<u>0.83</u>	163	<u>0.62</u>
FREEZING CYCLE TIME	70/21	<b>33</b>		34		36	
	80/27	34		36		38	
	90/32	34		<b>37</b>		40	
min.	100/38	35		38		42	
HARVEST CYCLE TIME	70/21	<b>4.7</b>		4.1		3.8	
	80/27	4.2		3.3		3.2	
	90/32	4.1		<b>2.6</b>		2.4	
min.	100/38	3.4		2.6		2.3	
HEAD PRESSURE	70/21	<b>210</b>	<u>14.8</u>	225	<u>15.8</u>	238	<u>16.7</u>
	80/27	221	<u>15.6</u>	244	<u>17.2</u>	254	<u>17.8</u>
	90/32	225	<u>15.8</u>	<b>260</b>	<u>18.3</u>	271	<u>19.1</u>
PSIG <u>kg/cm<sup>2</sup>G</u>	100/38	225	<u>15.8</u>	263	<u>18.5</u>	282	<u>19.8</u>
SUCTION PRESSURE	70/21	<b>50</b>	<u>3.5</u>	51	<u>3.6</u>	55	<u>3.8</u>
	80/27	51	<u>3.6</u>	52	<u>3.7</u>	57	<u>4.0</u>
	90/32	51	<u>3.6</u>	<b>53</b>	<u>3.7</u>	58	<u>4.1</u>
PSIG <u>kg/cm<sup>2</sup>G</u>	100/38	53	<u>3.7</u>	54	<u>3.8</u>	62	<u>4.4</u>

TOTAL HEAT OF REJECTION FROM CONDENSER	18,982 BTU/h [AT 90°F (32°C) / WT 70°F (21°C)]
TOTAL HEAT OF REJECTION FROM COMPRESSOR	2,600 BTU/h [AT 90°F (32°C) / WT 70°F (21°C)]
CONDENSER VOLUME	133 CU. IN (URC-14FE)

Note:

1. Pressure data is recorded at 5 minutes into freezing cycle. The data not in **bold** should be used for reference only.
2. We reserve the right to make changes in specifications and design without prior notice.

---

## IV. Service Diagnosis

### WARNING

1. This unit should be diagnosed and repaired only by qualified service personnel to reduce the risk of death, electric shock, serious injury, or fire.
2. Risk of electric shock. Use extreme caution and exercise safe electrical practices.
3. Moving parts (e.g., fan blade) can crush and cut. Keep hands clear.
4. **CHOKING HAZARD:** Ensure all components, fasteners, and thumbscrews are securely in place after the unit is serviced. Make sure that none have fallen into the storage bin.
5. Make sure all food zones in the icemaker and storage bin are clean after the unit is serviced. For cleaning procedures, see "VI. Cleaning and Maintenance."

### A. Diagnostic Procedure

The diagnostic procedure is basically a sequence check which can be used at unit startup or for system diagnosis. This procedure allows you to diagnose electrical system and component failures in normal operating conditions of 70°F (21°C) or warmer air and 50°F (10°C) or warmer water temperatures. Before conducting the diagnostic procedure, check for correct installation, proper voltage per unit nameplate, and adequate water supply. Check CB using the steps in "IV.B. Control Board Check." Check the dip switch settings to assure that S4 dip switch 3, 4, 7, 8, 9, & 10 and S5 dip switch 1 through 5 are in the factory default position. S4 dip switch 1, 2, 5, & 6 are cleaning adjustments and the settings are flexible. For factory default settings, see "II.C.2.a) Default Dip Switch Settings." As you go through the procedure, check to assure the components energize and de-energize correctly. If not, those components and controls are suspect.

- 1) Turn off the power supply, then access the control box. Clear any ice from BC.
- 2) Turn on the power supply, then move the control switch to the "ICE" position. A 5-second delay occurs. CB red "POWER OK" LED and green "BC CLOSED" LED come on. If red "POWER OK" LED is off on thermostatic BC unit (KM-1301SAH-E), clear ice away from the thermostatic bin control bulb in the storage bin area. If no ice is near the thermostatic bin control bulb or the LED does not come on even after clearing away ice, check thermostatic BC. See "IV.C.1. Thermostatic Bin Control Check." If yellow "BC OPEN" LED is on (indicating a full bin), confirm that CB K4 jumper is in place on thermostatic BC unit (KM-1301SAH-E) or check BC on mechanical BC unit (KM-1301SWH-E, KM-1301SRH-E). See "IV.C.2.a) Mechanical Bin Control Check."
- 3) **1-Minute Fill Cycle – LED 4 is on.** WV and X2 relay (auxiliary code T-0, U-0), X11 relay (auxiliary code U-1 and later) energize and the 1-minute fill cycle begins. After 1 minute, CB checks for a closed F/S. If F/S is closed, the harvest cycle begins. If closed, continue to step 4. If open, WV remains energized through additional 1-minute fill cycles until water fills the tank and closes F/S (low water safety). **Diagnosis:** If WV does not open, check the supply voltage at WV terminals, check continuity on the coil, confirm the screen or external filter isn't plugged (no water flow). If unit fails to start harvest, check for open F/S or bad 1-minute timer in CB. See "IV.D. Float Switch Check and Cleaning" and "IV.B. Control Board Check."

4) **Initial Harvest Cycle – LEDs 1, 4, and 2 are on.** WV and X2 relay (auxiliary code T-0, U-0), X11 relay (auxiliary code U-1 and later) remain energized, HGV, X1 relay (auxiliary code T-0, U-0), X10 relay (auxiliary code U-1 and later), Comp, and FMR energize. CB monitors the warming of the evaporator via the thermistor located on the suction line. When the thermistor reaches 48°F (9°C), CB reads a 3.9 kΩ signal from the thermistor and turns harvest termination over to the harvest timer (S4 dip switch 1 & 2). The harvest timer has settings of 60, 90, 120, and 180 seconds. For details, see "II.C.2.b) Harvest Timer (S4 dip switch 1 & 2)." When the harvest timer terminates, the harvest cycle is complete. CB checks the position of F/S and proceeds to the next cycle if it is closed, or calls for a 1-minute fill cycle if it is open. The minimum total time allowed by CB for a complete harvest cycle is 2 minutes.

WV is energized during harvest for a maximum of 6 minutes or the length of harvest minus 0 or 50 seconds (harvest pump timer (S4 dip switch 7)), whichever is shorter. LED 4 goes off when WV and X2 relay (auxiliary code T-0, U-0), X11 relay (auxiliary code U-1 and later) de-energize. LED 3 comes on and PM energizes and runs for the last 0 or 50 seconds of harvest depending on S4 dip switch 7 setting. **CAUTION! Do not adjust S4 dip switch 7 out of the factory default position on this model. Adjustment outside of the factory default position may result in damage to the icemaker.** For details, see "II.C.2.e) Harvest Pump Timer (S4 dip switch 7)."

PM is energized through the #5 pin (DBu wire) on the CB K1 ten-pin connector and the X1 relay (auxiliary code T-0, U-0), X10 relay (auxiliary code U-1 and later). When the harvest timer terminates, the harvest cycle is complete. CB checks the position of F/S and proceeds to the next cycle if it is closed or calls for a 1-minute fill cycle if it is open. The minimum total time allowed by CB for a complete harvest cycle is 2 minutes. **Diagnosis:** Check if Comp is running, HGV and WV still energized. Average harvest cycle at factory setting is 2 to 3 minutes. How long does initial harvest last? 1.5 minutes after initial harvest begins, touch Comp discharge line. Is it hot? If not, check refrigerant pressures and Comp operation. If it is hot, touch the inlet line to the evaporator. Is it hot? If it is hot and the freeze cycle is not starting, check the harvest timer adjustment (S4 dip switch 1 & 2), the thermistor for open circuit, the discharge line temperature, Comp efficiency, and if HGV is fully open. For a thermistor check, see "IV.E. Thermistor Check." Check that PM circulates water over evaporator for the last 50 seconds of harvest. If not, check X1 relay (auxiliary code T-0, U-0), X10 relay (auxiliary code U-1 and later) and S4 dip switch 3 & 4. If 1-minute fill cycle starts, see "IV.D. Float Switch Check and Cleaning."

5) **Freeze Cycle – LED 1 is on.** Comp and FMR remain energized, PM energizes or remains energized depending on harvest pump timer (S4 dip switch 7) setting. FM and LLV energize. HGV and X1 relay (auxiliary code T-0, U-0), X10 relay (auxiliary code U-1 and later) de-energize. The unit is held in freeze by a 5-minute short cycle protection timer (CB will not accept a signal from F/S). After the 5-minute short cycle protection timer terminates, CB turns freeze termination over to F/S. During the first 5 minutes of freeze, confirm that the evaporator temperature drops. After 5 minutes in freeze, disconnect black F/S connector from CB BLACK K5 connector. After a 15 second delay, the unit should switch out of the freeze cycle. **Diagnosis:** If the evaporator is not cold, check to see if HGV is still open or if TXV is not opening properly, if WV is continuing to fill the reservoir, if there are improper unit pressures,

an inoperative Comp, or an inoperative HM. If the unit switches out of freeze with F/S connector removed, but would previously not switch out of freeze with F/S connected (long freeze - 3 beep alarm), F/S may be sticking. To check and clean F/S, see "IV.D. Float Switch Check and Cleaning." If the unit remains in freeze longer than 15 seconds after disconnecting black F/S connector, replace CB.

Note: Normal freeze cycle will last 20 to 40 minutes depending on model and conditions. Cycle times and pressures should follow performance data provided in this manual. See "III.C. Performance Data."

- 6) **Pump-Out Cycle – (10/20 second pump-out) – LEDs 1, 3, and 2 are on. LED 4 is on when S4 dip switch 3 & 4 are set to 3 off and 4 on. CAUTION! Do not adjust S4 dip switch 3 & 4 to 3 off and 4 on. Adjustment to this position on this model prevents the pump motor from rotating in the pump-out direction.** For details, see "II.C.2.c) Pump-Out Timer (S4 dip switch 3 & 4)." Comp and FMR remain energized, HGV energizes. WV energizes if S4 dip switch 3 off and 4 on. LLV and FM de-energize. PM stops for 2 seconds, then reverses for 10/20 seconds depending on pump-out timer S4 dip switch 3 & 4 setting. When the pump-out timer terminates, the pump-out is complete. The pump-out frequency control is factory set for every 10th cycle, and generally no adjustment is required. However, where water quality is bad and the icemaker needs a pump-out more often, the pump-out frequency can be adjusted. The pump-out frequency control (S4 dip switch 5 & 6) can be set to have a pump-out occur every cycle, or every 2, 5, or 10 cycles. Timing of the first pump-out is dependent on S4 dip switch 5 & 6 settings. See the table below.

S4 Dip Switch Setting		Pump-Out Frequency	1st Pump-Out
No. 5	No. 6		
OFF	OFF	Every cycle	After 2nd freeze cycle
ON	OFF	Every 2 cycles	After 3rd freeze cycle
OFF	ON	Every 5 cycles	After 6th freeze cycle
ON	ON	Every 10 cycles	After 11th freeze cycle

**Diagnosis:** If PM does not reverse, check to see if CB S4 and S5 dip switch settings are in the factory default position. If S4 dip switch 3 and 4 are adjusted to 3 off and 4 on, WV and harvest pump timer relays energize. Once these relays energize, the pump motor rotates in the freeze cycle rotation. See "III.B. Wiring Diagrams." Check PM circuit and capacitor, check #5 pin (DBu wire) on CB K1 ten-pin connector for voltage, harvest pump timer X1 and X2 relays (auxiliary code T-0, U-0), X10 and X11 relays (auxiliary code U-1 and later). If water does not pump out, check and clean the check valve assembly and tubing.

- 7) **Normal Harvest Cycle** – same as the initial harvest cycle – Return to "IV.A.4) Initial Harvest Cycle."

## 8) Shutdown

### a) **Thermostatic Bin Control: KM-1301SAH-E**

When the unit is running hold ice in contact with the thermostatic bulb, the thermostatic BC switch opens within 10 seconds, shutting down the unit (CB red "POWER OK" LED is off). The bin control is factory set, and generally no adjustment is required. However, adjustment may be needed in some conditions, particularly at higher altitude locations. **Diagnosis:** See "IV.C.1. Thermostatic Bin Control Check."

### b) **Mechanical Bin Control: KM-1301SWH-E, KM-1301SRH-E**

See "IV.C.2.a) Mechanical Bin Control Check."

Legend: **BC**—bin control; **CB**—control board; **Comp**—compressor; **FM**—fan motor; **FMR**—fan motor-remote; **F/S**—float switch; **HGV**—hot gas valve; **HM**—headmaster (C.P.R.); **LLV**—liquid line valve; **PM**—pump motor; **TXV**—thermostatic expansion valve; **WV**—inlet water valve

## B. Control Board Check

Before replacing a control board that does not show a visible defect and that you suspect is bad, always conduct the following check procedure. This procedure will help you verify your diagnosis.

Alarm Reset: If the control board is in alarm (beeping), press the "ALARM RESET" button on the control board while the control board is beeping. **WARNING! Risk of electric shock. Care should be taken not to touch live terminals.** Once reset, the unit starts at the 1-minute fill cycle. For audible alarm information, see "II.C.1.a) LED Lights and Audible Alarm Safeties."

- 1) Check the dip switch settings to assure that S4 dip switch #3, 4, 7, 8, 9, & 10 and S5 dip switch 1 through 5 are in the factory default position. S4 dip switch 1, 2, 5, & 6 are cleaning adjustments and the settings are flexible. For factory default settings, see "II.C.2.a) Default Dip Switch Settings."
- 2) Move the control switch to the "ICE" position. If the red "POWER OK" LED is on, the control voltage is good. If the red "POWER OK" LED is off on a thermostatic bin control unit (KM-1301SAH-E), clear ice away from the thermostatic bin control bulb in the storage bin area. If no ice is near the thermostatic bin control bulb or the red "POWER OK" LED does not come on even after clearing away ice, check the thermostatic bin control. See "IV.C.1. Thermostatic Bin Control Check." If the thermostatic bin control is okay (closed) or you are diagnosing a mechanical bin control unit and the red "POWER OK" LED is off, check the fuse, control switch contacts, high-pressure switch, and control transformer secondary circuit. Transformer output is 10.5V at 115V primary input. If the secondary circuit has proper voltage and the red LED is off, the control board is bad and should be replaced.

If the secondary circuit does not have proper voltage, check the control transformer primary circuit. Check for 115V at the control board K1 ten-pin connector. Check the #10 pin (BR wire) to a white neutral wire for 115V. (Always choose a white neutral wire to establish a good neutral connection when checking voltages.) For additional checks, see "IV.G.1. No Ice Production."

- 3) The "OUTPUT TEST" button provides a relay sequence test. Make sure the control switch is in the "ICE" position, then press the "OUTPUT TEST" button. The correct lighting sequence is 1, 4, 3, 2. Note that the order of the LEDs from the outer edge of the control board is 1, 4, 3, 2. Components (e.g., compressor) will cycle during the test. Following the test, the icemaker resumes operation. If the LEDs do not light as described above, the control board is bad and should be replaced.
- 4) To verify voltage output from the control board to the components, slide the control board K1 ten-pin connector out far enough to allow multimeter lead contact. With the unit in the cycle to be tested, check output voltage from the corresponding pin on the control board K1 ten-pin connector to ground. If output voltage is not found and the appropriate LED is on, the control board is bad and should be replaced.

## C. Bin Control Check

### 1. Thermostatic Bin Control Check: KM-1301SAH-E

To check the thermostatic bin control, follow the steps below.

#### CAUTION

When the ambient temperature is below 45°F (7°C), the thermostatic bin control switch opens and shuts down the icemaker even if the ice storage bin is empty. When the thermostat is set in the prohibited range, the icemaker operates continuously even if the ice storage bin is filled with ice. Setting in the prohibited range may result in severe damage to the icemaker.

The thermostatic bin control is factory set, and generally no adjustment is required. However, adjustment may be needed in some conditions, particularly at higher altitude locations. Note that when the thermostatic bin control switch is open, the control board red "POWER OK" LED is off.

- 1) Turn off the power supply.
- 2) Remove the front panel, then move the control switch to the "OFF" position.
- 3) Clear any ice away from the thermostatic bin control bulb.
- 4) Remove the control box cover, then disconnect the thermostatic bin control wires from the thermostatic bin control switch.
- 5) Hold your hand around the thermostatic bulb to warm it up.
- 6) Check for continuity across the thermostatic bin control switch. If closed, continue to step 6. If open, adjust or replace the thermostatic bin control.
- 7) With the multimeter test leads still in place, hold ice on the thermostatic bin control bulb to lower the temperature. Within 10 seconds, the thermostatic bin control switch should open (no continuity). If it remains closed, adjust or replace the thermostatic bin control.

### 2. Mechanical Bin Control Check and Cleaning: KM-1301SWH-E, KM-1301SRH-E

#### a) Mechanical Bin Control Check

To check the mechanical bin control switch, follow the steps below.

- 1) Turn off the power supply.
- 2) Remove the front panel, then move the control switch to the "OFF" position.
- 3) Remove the control box cover, then clear any ice away from the mechanical bin control.
- 4) Check bin control cable and wire harness connections. See Fig. 1.
- 5) Disconnect the red connector from the control board RED K4 connector.
- 6) Check for continuity across the wires of the red connector. When the actuator paddle is not engaged, the mechanical bin control switch is closed. If open, check that bin control cable connector and the wire harness connector(s) are properly connected and that the actuator paddle is not sticking. Clean if necessary. See "IV.C.2.b) Mechanical Bin Control Cleaning." If the mechanical bin control switch still reads open, replace the mechanical bin control.



- 7) Press the actuator paddle, check for continuity across the wires of the red connector. When the actuator paddle is engaged, the mechanical bin control switch is open. If closed, check that the actuator paddle is not restricted. Clean if necessary. See "IV.C.2.b) Mechanical Bin Control Cleaning." If the mechanical bin control switch still reads closed, replace the mechanical bin control.
- 8) Reconnect the red connector to the control board RED K4 connector, then move the control switch to the "ICE" position. Turn on the power supply.
- 9) Check that the green "BC CLOSED" LED on the control board is on.
- 10) Allow the unit to cycle on. Press and hold the actuator paddle. The yellow "BC OPEN" LED should be on and the unit should shut down according to the chart below. If it does not, replace the control board.

Cycle at Mechanical Bin Control Activation	Shutdown
Fill Cycle	15 seconds after activation.
Harvest Cycle	At the end of the harvest cycle, or up to 15 seconds into the freeze cycle if activated at the end of the harvest cycle.
Freeze Cycle	15 seconds after activation if activated at least 15 seconds before the 5-minute short cycle protection timer terminates. Otherwise, at the end of the next harvest cycle.

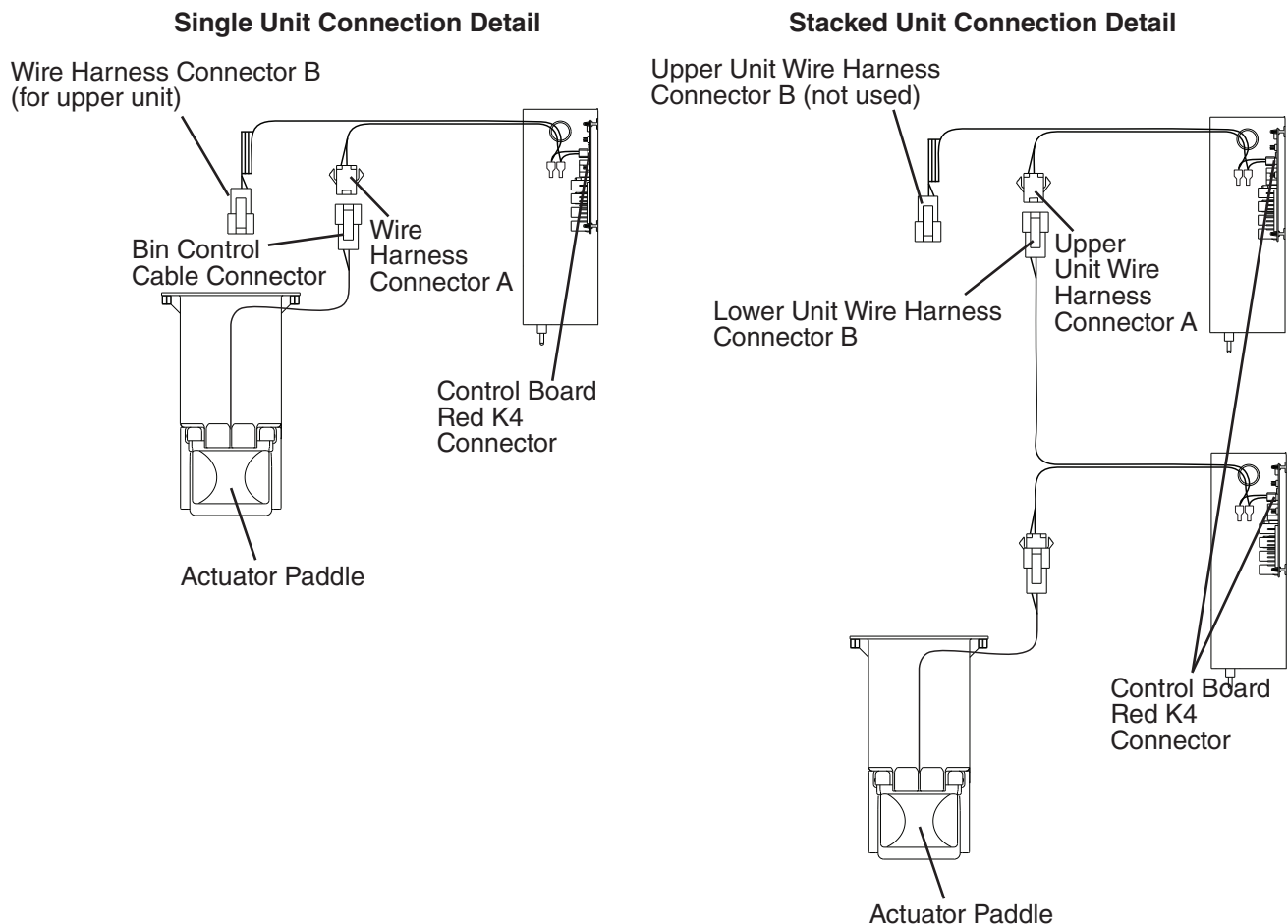

**Fig. 1**

### b) Mechanical Bin Control Cleaning

Scale may build up on the mechanical bin control. Scale can cause the actuator paddle and magnet to stick. In this case, the mechanical bin control should be cleaned.

#### **⚠ WARNING**

**CHOKING HAZARD:** Ensure all components, fasteners, and thumbscrews are securely in place after the unit is serviced. Make sure that none have fallen into the storage bin.

- 1) Turn off the power supply.
- 2) Remove the front panel, then move the control switch to the "OFF" position.
- 3) Clear any ice away from the mechanical bin control.
- 4) Disconnect the bin control cable connector, then remove the mechanical bin control assembly from the unit.
- 5) Remove the actuator paddle from the switch mount. See Fig. 2.
- 6) Wipe down the mechanical bin control assembly with a mixture of 1 part Hoshizaki "Scale Away" and 25 parts warm water. Rinse the parts thoroughly with clean water.
- 7) Reassemble the mechanical bin control assembly and replace it in its correct position.  
Note: If the magnet was removed for cleaning, be sure to replace it in its correct position.
- 8) Reconnect the bin control cable connector.
- 9) Move the control switch to the "ICE" position.
- 10) Replace the front panel in its correct position.
- 11) Turn on the power supply to start the automatic icemaking process.

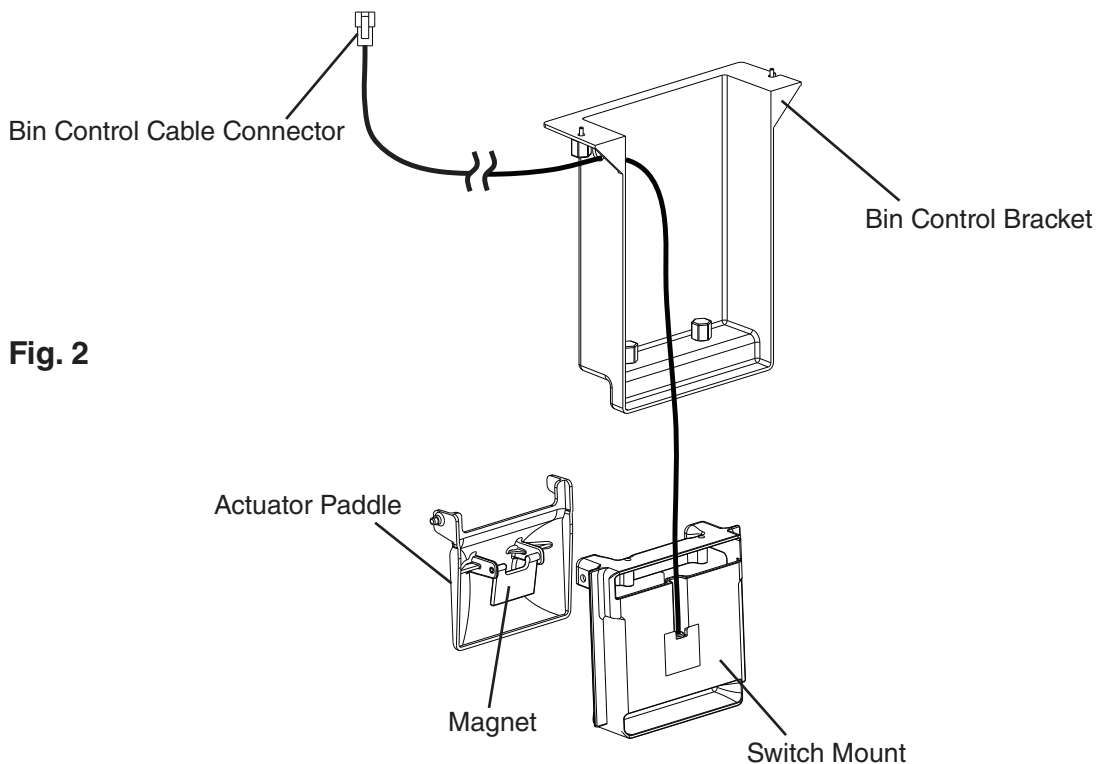

**Fig. 2**

## D. Float Switch Check and Cleaning

The float switch is used to determine that there is sufficient water in the tank after the 1-minute fill cycle and after each harvest cycle. The float switch is also used to determine that the appropriate volume of water has been converted into ice before switching out of the freeze cycle. No adjustment is required.

### 1. Float Switch Check

To check the float switch, follow the steps below.

- 1) Turn off the power supply.
- 2) Remove the front panel, then move the control switch to the "OFF" position.
- 3) Remove the insulation panel, then remove the drain plug located on the lower front part of the ice chute. See Fig. 3. Allow the water tank to drain.
- 4) Replace the drain plug in its correct position. Be careful not to cross thread it.
- 5) Remove the control box cover.
- 6) Disconnect the black float switch connector from the control board BLACK K5 connector.
- 7) Check for continuity across the float switch leads. With the water tank empty, the float switch should be open. If open, continue to step 8. If closed, follow the steps in "IV.D.2. Float Switch Cleaning." After cleaning the float switch, check it again. Replace if necessary.
- 8) Reconnect the black float switch connector to the control board BLACK K5 connector, then replace the control box cover in its correct position.
- 9) Move the control switch to the "ICE" position. Replace the insulation panel and the front panel in their correct positions, then turn on the power supply. After 1 minute, the 1-minute fill cycle should end and the initial harvest cycle should begin. If the initial harvest cycle begins, the float switch is good and the check is complete. If the initial harvest cycle does not begin, continue to step 10.
- 10) Turn off the power supply.
- 11) Remove the front panel, then move the control switch to the "OFF" position.
- 12) Remove the control box cover.
- 13) Disconnect the black float switch connector from the control board BLACK K5 connector.
- 14) Check for continuity across the float switch leads. With the water tank full, the float switch should be closed. If the float switch is closed and the icemaker will not switch from the 1-minute fill cycle to the initial harvest cycle, replace the control board.  
If open, confirm that the water tank is full. If the tank is not full, check the water supply, water filters, and inlet water valve. If the tank is full, follow the steps in "IV.D.2. Float Switch Cleaning." After cleaning the float switch, check it again. Replace if necessary.

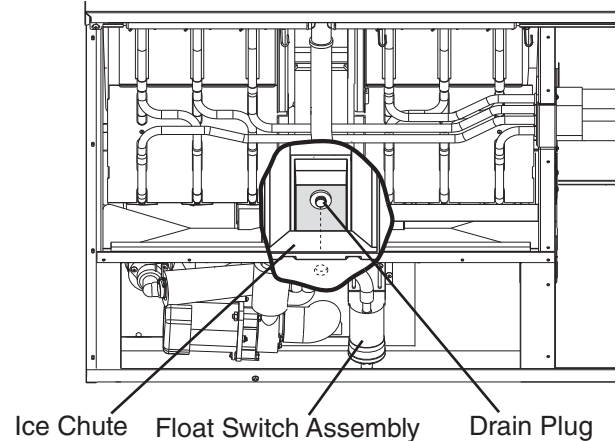

**Fig. 3**

## 2. Float Switch Cleaning

Depending on local water conditions, scale may build up on the float switch. Scale on the switch can cause the float to stick. In this case, the float switch should be cleaned.

- 1) Turn off the power supply.
- 2) Remove the front panel, then move the control switch to the "OFF" position.
- 3) Remove the insulation panel, then remove the drain plug located on the lower front part of the ice chute. See Fig. 3. Allow the water tank to drain.
- 4) Replace the drain plug in its correct position. Be careful not to cross thread it.
- 5) Disconnect the vent tube and the flush tube from the top of the float switch, then remove the float switch assembly from the mounting bracket and remove the rubber boot from the bottom of the float switch assembly. See Fig. 4.
- 6) Remove the retainer rod from the bottom of the float switch assembly, then remove the float. Be careful not to bend the retainer rod excessively when removing it.
- 7) Wipe down the float switch assembly's housing, shaft, float, and retainer rod with a mixture of 1 part Hoshizaki "Scale Away" and 25 parts warm water. Clean the inside of the rubber boot and hose with cleaning solution. Rinse the parts thoroughly with clean water.
- 8) Reassemble the float switch assembly and replace it and the rubber boot in their correct positions. Reconnect the vent tube and the flush tube.
- 9) Move the control switch to the "ICE" position.
- 10) Replace the insulation panel and front panel in their correct positions.
- 11) Turn on the power supply to start the automatic icemaking process.

**Fig. 4**

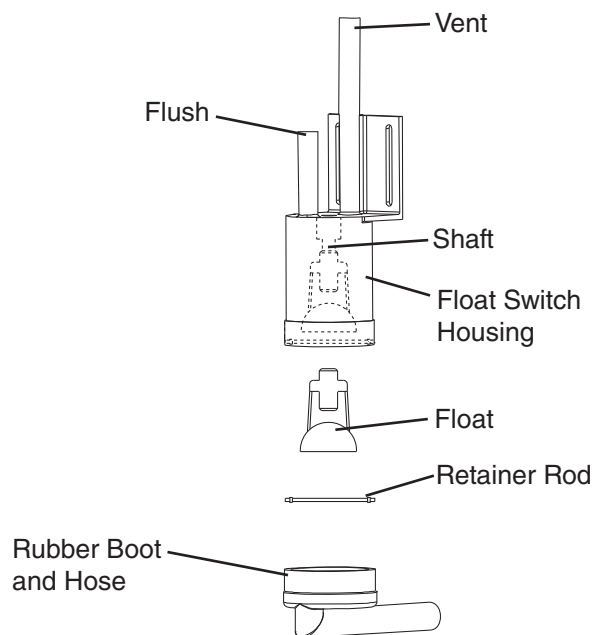

## E. Thermistor Check

To check thermistor resistance, follow the steps below.

- 1) Turn off the power supply.
- 2) Remove the front panel, then move the control switch to the "OFF" position.
- 3) Remove the control box cover.
- 4) Remove the thermistor.
- 5) Immerse the thermistor sensor portion in a glass containing ice and water for 2 or 3 minutes.
- 6) Disconnect the white thermistor connector from the control board WHITE K3 connector and check the resistance between thermistor leads. Normal reading is within 4.7 to 6.2 k $\Omega$ . If outside the normal reading, replace the thermistor. See "V.B. Important Notes for Component Replacement." If inside the normal reading, continue to the next step.
- 7) Replace the thermistor in its correct position. See "V.B. Important Notes for Component Replacement."
- 8) Reconnect the white thermistor connector to the control board WHITE K3 connector.
- 9) Replace the control box cover in its correct position, then turn on the power supply.
- 10) Move the control switch to the "ICE" position.
- 11) Once the harvest cycle starts, begin timing the harvest cycle.
- 12) The harvest timer should terminate and end the harvest cycle within 2 to 3 minutes. If the harvest timer does not terminate and end the harvest cycle, the harvest timer is bad and the control board should be replaced.

## F. Adjustment of Water Regulating Valve (water-cooled model)

The water regulating valve (also called "water regulator") is factory set, and generally no adjustment is required. However, when necessary, adjust the water regulator using the following procedures.

- 1) Prepare a thermometer to check the condenser drain temperature. Attach a pressure gauge to the high-side line of the system.
- 2) Five minutes after a freeze cycle starts, confirm that the thermometer reads 104°F to 115°F (40°C to 46°C). If it does not, use a flat blade screwdriver to rotate the adjustment screw on the water-regulating valve until the temperature is in the proper range (rotate counterclockwise to raise the temperature or clockwise to lower the temperature). See Fig. 5. Next, check that the reference pressure is in the range indicated in the Head Pressure table in the Performance Data section. If it is not in the proper range, verify the refrigerant charge.
- 3) Check that the condenser drain temperature is stable.

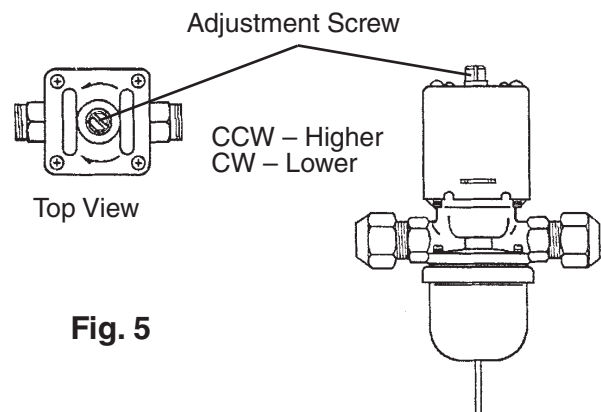

Fig. 5

## G. Diagnostic Charts

Before consulting the diagnostic charts, check for correct installation, proper voltage per unit nameplate, and adequate water supply. Check CB using the steps in "IV.B. Control Board Check." Check the dip switch settings to assure that S4 dip switch 3, 4, 7, 8, 9, & 10 and S5 dip switch 1 through 5 are in the factory default position. S4 dip switch 1, 2, 5, & 6 are cleaning adjustments and the settings are flexible. For factory default settings, see "II.C.3.a) Default Dip Switch Settings."

### 1. No Ice Production

No Ice Production - Possible Cause	
1. Power Supply	a) Off, blown fuse, or tripped breaker.
	b) Not within specifications.
2. Main Transformer (230V/115V)	a) Coil winding open or shorted.
3. Water Supply	a) Water supply off or improper water pressure.
	b) External water filters clogged.
4. Thermostatic Bin Control. See "IV.C.1. Thermostatic Bin Control Check."	a) Tripped with bin filled with ice.
	b) Ambient temperature too cool.
	c) Set too warm.
	d) Bulb out of position.
	e) Bad contacts.
5. Fuse (Control Box)	a) Blown.
6. Control Switch	a) Bad contacts.
7. High-Pressure Switch	a) Bad contacts.
	b) Dirty air filter or condenser.
	c) Ambient or condenser water temperature too warm.
	d) Refrigerant overcharged.
	e) Fan not operating (air-cooled and remote air-cooled models).
	f) Refrigerant lines or components plugged.
	g) Condenser water pressure too low or off (water-cooled model).
	h) Headmaster (C.P.R.) open (remote condenser unit).
8. Control Transformer (115V/10.5V)	a) Coil winding open or shorted.
9. Control Board See "IV.B. Control Board Check."	a) In alarm.
	b) Defective.
10. Mechanical Bin Control See "IV.C.2. Mechanical Bin Control Check and Cleaning."	a) Tripped with bin filled with ice.
	b) Actuator does not move freely.
	c) Defective.
11. Thermistor See "IV.E. Thermistor Check."	a) Leads shorted or open.
12. Hot Gas Valve	a) Open in freeze cycle.
	b) Closed in harvest cycle.
13. Inlet Water Valve	a) Mesh filter or orifice clogged.
	b) Coil winding open.
	c) Open in freeze cycle.

<b>No Ice Production - Possible Cause</b>	
14. Float Switch See "IV.D. Float Switch Check and Cleaning."	a) Float does not move freely.
	b) Defective.
15. Compressor	a) Compressor relay/magnetic contactor contacts bad or coil winding open.
	b) Start capacitor or run capacitor defective.
	c) Internal overload protector open.
	d) Starter contacts bad or coil winding open.
	e) Protector tripped.
	f) Compressor defective.
16. Pump Motor	a) Motor winding open.
	b) Bearing worn out or locked rotor.
	c) Defective capacitor.
	d) Mechanical seal worn out.
17. Pump-Out Check Valve	a) Leaking by.
18. Water System	a) Water leaks causing short freeze time.
19. Fan Motor	a) Motor winding open.
	b) Bearing worn out or locked rotor.
	c) Defective capacitor.
20. Liquid Line Valve (if applicable)	a) Closed in freeze cycle.
	b) Open in harvest cycle.
21. Expansion Valve (TXV)	a) Bulb loose.
	b) Operating erratically.
22. Headmaster (C.P.R.) (remote condenser unit)	a) Open out of temperature/pressure range.
23. Water Regulating Valve (water-cooled model) See "IV.F. Adjustment of Water Regulating Valve."	a) Insufficient water supply.
	b) Out of adjustment.

## 2. Freeze Up

Defrost and clean the unit prior to diagnosing freeze up. See "VI.A. Cleaning and Sanitizing Instructions."

Freeze Up - Possible Cause	
Harvest Cycle	
1. Evaporator	a) Scaled up. b) Damaged.
2. Separators	a) Out of position.
3. Cube Guide	a) Out of position.
4. Spray Tubes and/or Spray Guides	a) Dirty. b) Out of position.
5. Refrigerant Charge	a) Low.
6. Ambient Temperature	a) Too cool.
7. Water Supply	a) Low water pressure. b) External water filters clogged. c) Insufficient water line size. Minimum 3/8" nominal ID (10 mm nominal OD)
8. Thermostatic Bin Control See "IV.C.1. Thermostatic Bin Control Check."	a) Extension bracket not installed. b) Bulb out of position. c) Bad contacts.
9. Control Board See "IV.B. Control Board Check."	a) Harvest timer set too short. b) Defective.
10. Mechanical Bin Control See "IV.C.2. Mechanical Bin Control Check and Cleaning."	a) Actuator does not move freely.
11. Thermistor See "IV.E. Thermistor Check."	a) Loose, disconnected, or defective.
12. Hot Gas Valve	a) Closed.
13. Inlet Water Valve	a) Water valve screen clogged.
14. Liquid Line Valve (if applicable)	a) Open.
15. Expansion Valve (TXV)	a) Defective.
16. Water Regulating Valve (water-cooled model)	a) Leaking by. b) Defective.



<b>Freeze Up - Possible Cause</b>	
<b>Freeze Cycle</b>	
1. Evaporator	a) Scaled up.
	b) Damaged.
2. Separators	a) Out of position.
3. Spray Tubes and/or Spray Guides	a) Dirty.
	b) Out of position.
4. Refrigerant charge.	a) Low.
5. Check Valve	a) Defective.
6. Control Board See "IV.B. Control Board Check."	a) Freeze timer set incorrectly.
	b) Defective.
7. Inlet Water Valve	a) Leaking by.
8. Float Switch See "IV.D. Float Switch Check and Cleaning."	a) Float does not move freely.
	b) Defective.
9. Pump Motor	a) RPM too slow.
10. Expansion Valve (TXV)	a) Defective.
11. Headmaster (C.P.R.) (remote condenser unit)	a) Defective.
12. Water Regulating Valve (water-cooled model) See "IV.F. Adjustment of Water Regulating Valve."	a) Out of adjustment.

### 3. Low Ice Production

Low Ice Production - Possible Cause	
Long Harvest Cycle	
1. Evaporator	a) Scaled up.
2. Spray Tubes and/or Spray Guides	a) Dirty.
	b) Out of position.
3. Refrigerant Charge	a) Low.
4. Water Supply	a) Low water pressure.
	b) External water filters clogged.
	c) Insufficient water line size. Minimum 3/8" nominal ID (10 mm nominal OD)
	d) Too cold.
5. Control Board See "IV.B. Control Board Check."	a) Thermistor connection loose (K3).
	b) Defective.
6. Thermistor See "IV.E. Thermistor Check."	a) Loose, disconnected, or defective.
7. Hot Gas Valve	a) Erratic or closed.
8. Inlet Water Valve	a) Water valve screen clogged.
9. Compressor	a) Inefficient or off.
10. Liquid Line Valve (if applicable)	a) Erratic or open.
11. Expansion Valve (TXV)	a) Defective.
12. Water Regulating Valve (water-cooled model)	a) Leaking by.
Long Freeze Cycle	
1. Evaporator	a) Scaled up.
2. Refrigerant Charge	a) Low.
3. Air Filter (air-cooled model)	a) Clogged.
4. Condenser (air-cooled and remote air-cooled models)	a) Clogged.
5. Condenser (water-cooled model)	a) Water temperature out of specification.
6. Control Board See "IV.B. Control Board Check."	a) Float switch connection loose (K5).
	b) Defective.
7. Hot Gas Valve	a) Erratic or open.
8. Inlet Water Valve	a) Leaking by.
9. Float Switch See "IV.D. Float Switch Check and Cleaning."	a) Float does not move freely or defective switch.
10. Compressor	a) Inefficient or off.
11. Pump Motor	a) RPM too slow.
12. Liquid Line Valve (if applicable)	a) Erratic or closed.
13. Expansion Valve (TXV)	a) Bulb loose.
	b) Defective.
14. Headmaster (C.P.R.) (remote condenser unit)	a) Not bypassing.
15. Water Regulating Valve (water-cooled model) See "IV.F. Adjustment of Water Regulating Valve."	a) Out of adjustment.

---

## V. Replacement of Components

### ⚠ WARNING

1. This unit should be diagnosed and repaired only by qualified service personnel to reduce the risk of death, electric shock, serious injury, or fire.
2. Move the control switch to the "OFF" position and turn off the power supply before servicing. Lockout/Tagout to prevent the power from being turned back on inadvertently.
3. **CHOKING HAZARD:** Ensure all components, fasteners, and thumbscrews are securely in place after the unit is serviced. Make sure that none have fallen into the storage bin.
4. Make sure all food zones in the icemaker and storage bin are clean after the unit is serviced. For cleaning procedures, see "VI. Cleaning and Maintenance."

## A. Service for Refrigerant Lines

### ⚠ WARNING

1. Repairs requiring the refrigeration circuit to be opened must be performed by properly trained and EPA-certified service personnel.
2. Always recover the refrigerant and store it in an approved container. Do not discharge the refrigerant into the atmosphere.
3. Use an electronic leak detector or soap bubbles to check for leaks. Add a trace of refrigerant to the system (if using an electronic leak detector), and then raise the pressure using nitrogen gas (140 PSIG). DO NOT use R-404A as a mixture with pressurized air for leak testing.

### CAUTION

1. Do not leave the system open for longer than 15 minutes when replacing or servicing parts. The Polyol Ester (POE) oils used in R-404A units can absorb moisture quickly. Therefore it is important to prevent moisture from entering the system when replacing or servicing parts.
2. Always install a new drier every time the sealed refrigeration system is opened.
3. Do not replace the drier until after all other repair or replacement has been made. Install the new drier with the arrow on the drier in the direction of the refrigerant flow.
4. When brazing, protect the drier by using a wet cloth to prevent the drier from overheating. Do not allow the drier to exceed 250°F (121°C).

### 1. Refrigerant Recovery

The icemaker is provided with refrigerant service valves. Using proper refrigerant practices, recover the refrigerant from the service valves and store it in an approved container. Do not discharge the refrigerant into the atmosphere.

## 2. Brazing

### **▲ WARNING**

1. R-404A itself is not flammable at atmospheric pressure and temperatures up to 176°F (80°C).
2. R-404A itself is not explosive or poisonous. However, when exposed to high temperatures (open flames), R-404A can be decomposed to form hydrofluoric acid and carbonyl fluoride both of which are hazardous.
3. Do not use silver alloy or copper alloy containing arsenic.
4. Use an electronic leak detector or soap bubbles to check for leaks. Add a trace of refrigerant to the system (if using an electronic leak detector), and then raise the pressure using nitrogen gas (140 PSIG). DO NOT use R-404A as a mixture with pressurized air for leak testing.

- 1) Braze all fittings while purging with nitrogen gas flowing at a pressure of 3 to 4 PSIG.

Note: Because the pipes in the evaporator case are specially coated to resist corrosion, it is important to make connections outside the evaporator case when possible. If it is necessary to braze inside the evaporator case, use sandpaper to remove the coating from the brazing connections before unbrazing the components.

### **CAUTION**

1. Always install a new drier every time the sealed refrigeration system is opened.
2. Do not replace the drier until after all other repair or replacement has been made. Install the new drier with the arrow on the drier in the direction of the refrigerant flow.
3. When brazing, protect the drier by using a wet cloth to prevent the drier from overheating. Do not allow the drier to exceed 250°F (121°C).

- 2) Use an electronic leak detector or soap bubbles to check for leaks. Add a trace of refrigerant to the system (if using an electronic leak detector), and then raise the pressure using nitrogen gas (140 PSIG). DO NOT use R-404A as a mixture with pressurized air for leak testing.

## 3. Evacuation and Recharge (R-404A)

- 1) Attach a vacuum pump to the system. Be sure to connect the charging hoses to both high and low-side service valves.

### **IMPORTANT**

The vacuum level and vacuum pump may be the same as those for current refrigerants. However, the rubber hose and gauge manifold to be used for evacuation and refrigerant charge should be exclusively for POE oils.

- 2) Turn on the vacuum pump. Open the gauge manifold valves, then open the high and low-side service valves. Never allow the oil in the vacuum pump to flow backwards.
- 3) Allow the vacuum pump to pull down to a 29.9" Hg vacuum. Evacuating period depends on pump capacity.

- 4) Close the low-side valve and high-side valve on the gauge manifold.
- 5) Disconnect the gauge manifold hose from the vacuum pump and attach it to a refrigerant service cylinder. Remember to loosen the connection and purge the air from the hose. For air-cooled and water-cooled models, see the nameplate for the required refrigerant charge. For remote air-cooled model, see the rating label inside the icemaker. Hoshizaki recommends only virgin refrigerant or reclaimed refrigerant which meets ARI Standard 700 (latest edition) be used.
- 6) A liquid charge is required when charging an R-404A system (to prevent fractionation). Place the service cylinder on the scales; if the service cylinder is not equipped with a dip tube, invert the service cylinder, then place it on the scales. Open the high-side valve on the gauge manifold.
- 7) Allow the system to charge with liquid until the proper charge weight is met.
- 8) If necessary, add any remaining charge to the system through the low-side.  
**CAUTION! To prevent compressor damage, use a throttling valve or liquid dispensing device to add the remaining liquid charge through the low-side service valve with the unit running.**
- 9) Close the high and low-side service valves. Close the high and low-side gauge manifold valves, then disconnect the gauge manifold hoses.
- 10) Cap the service valves to prevent a possible leak.

## B. Important Notes for Component Replacement

### CAUTION

When replacing a component listed below, see the notes to help ensure proper operation.

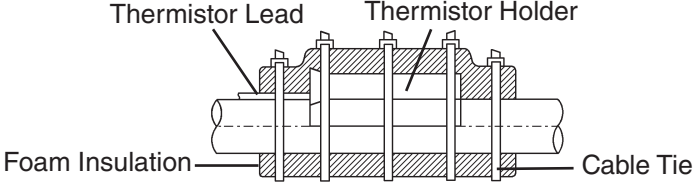
Component	Notes
Compressor	Install a new start capacitor, run capacitor, and start relay.
Expansion Valve	<ul style="list-style-type: none"> <li>• Attach the expansion valve bulb to the suction line in the same location as the previous bulb.</li> <li>• The bulb should be between the 10 and 2 o'clock position on the tube.</li> <li>• Secure the bulb with the clamp and holder, then insulate it.</li> </ul>
Hot Gas Valve Liquid Line Valve	<ul style="list-style-type: none"> <li>• Replace the strainer when replacing the hot gas valve.</li> <li>• Use copper tube of the same diameter and length when replacing valve lines.</li> </ul>
Fan Motor	Install a new capacitor.
Pump Motor	Install a new capacitor.
Thermistor	<ul style="list-style-type: none"> <li>• Attach the new thermistor to the suction line in the same location as the previous thermistor.</li> <li>• The thermistor should be at the 12 o'clock position on the tube.</li> <li>• Smoothly fill the recessed area of the thermistor holder with high thermal conductive type sealant. Hoshizaki America part number 4A0683-01 (Silicone Heat Sink Compound 10-8108 manufactured by GC Electronics), KE-4560 RTV (manufactured by ShinEtsu Silicones), or equivalent are recommended.</li> <li>• Secure the thermistor with the holder, then insulate it.</li> <li>• Be very careful to prevent damage to the leads.</li> </ul> <div style="text-align: center; margin-top: 10px;">  </div>

---

## VI. Cleaning and Maintenance

This icemaker must be cleaned and maintained in accordance with the documentation and labels provided with the icemaker. Consult with your local distributor about cleaning and maintenance service. To obtain the name and phone number of your local distributor, contact your nearest Hoshizaki Service office (listed in the Instruction Manual and at [www.hoshizaki.com](http://www.hoshizaki.com)).

### WARNING

1. Except as specified below, only qualified service technicians should attempt to service this icemaker.
2. **CHOKING HAZARD:** Ensure all components, fasteners, and thumbscrews are securely in place after any cleaning or maintenance is done to the unit. Make sure that none have fallen into the storage bin.
3. This appliance must not be cleaned by use of a water jet.
4. To prevent possible damage, do not clean the plastic parts with water above 104°F (40°C) or in a dishwasher.
5. The storage bin is for ice use only. Do not store anything else in the storage bin.

## A. Cleaning and Sanitizing Instructions

### Performed by Qualified Service Technician

Hoshizaki recommends cleaning and sanitizing this unit at least once a year. More frequent cleaning and sanitizing, however, may be required in some existing water conditions.

### WARNING

1. To prevent injury to individuals and damage to the icemaker, do not use ammonia type cleaners.
2. Carefully follow any instructions provided with the bottles of cleaning and sanitizing solution.
3. Always wear liquid-proof gloves and goggles to prevent the cleaning and sanitizing solutions from coming into contact with skin or eyes.
4. To prevent damage to the water pump seal, do not operate the icemaker with the control switch in the "WASH" position when the water tank is empty.

## 1. Cleaning Procedure

- 1) Dilute 27 fl. oz. (800 ml) of Hoshizaki "Scale Away" with 5 gal. (19 l) of warm water.
- 2) Remove all ice from the evaporator and the storage bin.

Note: To remove cubes on the evaporator, turn off the power supply and turn it back on after 3 minutes. The harvest cycle starts and the cubes will be removed from the evaporator.

- 3) Turn off the power supply.
- 4) Remove the front panel, then remove the insulation panel by first removing the thumbscrew, lifting up the panel slightly and pulling it towards you.

- 5) Remove the drain plug located on the lower front part of the ice chute. See Fig. 6. Allow the water tank to drain.
- 6) Replace the drain plug in its correct position. Be careful not to cross thread it.
- 7) In bad or severe water conditions, clean the float switch assembly as described below. Otherwise, continue to step 8.
  - a. Disconnect the vent tube and the flush tube from the top of the float switch, then remove the float switch assembly. Remove the rubber boot from the bottom of the assembly.
  - b. Remove the retainer rod from the bottom of the float switch housing, then remove the float. Be careful not to bend the retainer rod excessively when removing it.
  - c. Wipe down the float switch assembly's housing, shaft, float, and retainer rod with cleaning solution. Clean the inside of the rubber boot and hose with cleaning solution. Rinse the parts thoroughly with clean water.
  - d. Reassemble the float switch assembly and replace it and the rubber boot in their correct positions. Reconnect the vent tube and the flush tube.
- 8) Pour the cleaning solution into the water tank.
- 9) Move the control switch on the control box to the "WASH" position.
- 10) Replace the insulation panel and the front panel in their correct positions.
- 11) Turn on the power supply to start the washing process.
- 12) Turn off the power supply after 30 minutes.
- 13) Remove the front panel and the insulation panel.
- 14) Remove the drain plug. Allow the water tank to drain. Replace the drain plug and the insulation panel in their correct positions.

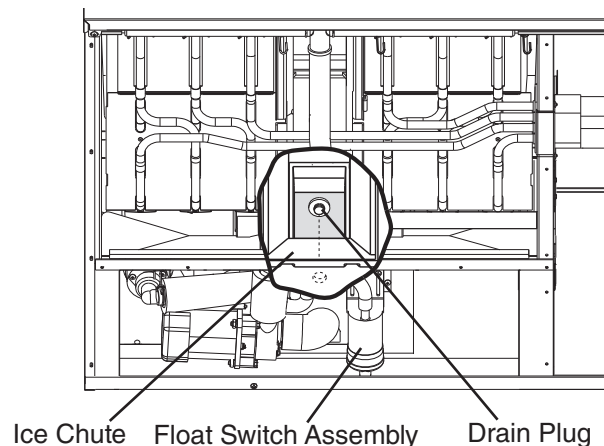

**Fig. 6**



- 15) Move the control switch to the "ICE" position.
- 16) Replace the front panel in its correct position.
- 17) Turn on the power supply to fill the water tank with water.
- 18) Turn off the power supply after 3 minutes.
- 19) Remove the front panel.
- 20) Move the control switch to the "WASH" position.
- 21) Replace the front panel in its correct position.
- 22) Turn on the power supply to rinse off the cleaning solution.
- 23) Turn off the power supply after 5 minutes.
- 24) Remove the front panel and the insulation panel.
- 25) Remove the drain plug. Allow the water tank to drain. Replace the drain plug and the insulation panel in their correct positions.  
Note: Do not replace the insulation panel when you proceed to "2. Sanitizing Procedure."
- 26) Repeat steps 15 through 25 three more times to rinse thoroughly.  
Note: If you do not sanitize the icemaker, go to step 9 in "2. Sanitizing Procedure."

## **2. Sanitizing Procedure - Following Cleaning Procedure**

- 1) Dilute 2.5 fl. oz. (74 ml or 5 tbs) of a 5.25% sodium hypochlorite solution (chlorine bleach) with 5 gal. (19 l) of warm water.
- 2) Pour the sanitizing solution into the water tank.
- 3) Replace the insulation panel and the front panel in their correct positions.  
Note: Make sure the control switch is in the "WASH" position.
- 4) Turn on the power supply to start the sanitizing process.
- 5) Turn off the power supply after 15 minutes.
- 6) Remove the front panel and the insulation panel.
- 7) Remove the drain plug. Allow the water tank to drain. Replace the drain plug and the insulation panel in their correct positions.
- 8) Repeat steps 15 through 25 in "1. Cleaning Procedure" two times to rinse thoroughly.
- 9) Move the control switch to the "ICE" position.
- 10) Replace the front panel in its correct position.
- 11) Clean the storage bin liner using a neutral cleaner. Rinse thoroughly after cleaning.
- 12) Turn on the power supply to start the automatic icemaking process.

## B. Maintenance

The maintenance schedule below is a guideline. More frequent maintenance may be required depending on water quality, the icemaker's environment, and local sanitation regulations.

### **⚠ WARNING**

1. Except as specified below, only qualified service technicians should attempt to service this icemaker.
2. Move the power switch to the "OFF" position and disconnect power before servicing.

#### **1. Stainless Steel Exterior - Performed by Qualified Service Technician or Owner/Manager**

To prevent corrosion, wipe the exterior occasionally with a clean, soft cloth. Use a damp cloth containing a neutral cleaner to wipe off oil or dirt buildup.

#### **2. Storage Bin and Scoop - Performed by Qualified Service Technician or Owner/Manager**

Clean the scoop and the storage bin liner using a neutral cleaner. Rinse thoroughly after cleaning.

#### **3. Air Filters (air-cooled model) - Performed by Qualified Service Technician or Owner/Manager**

Plastic mesh air filters remove dirt and dust from the air and keep the condenser from getting clogged. As the filters get clogged, the icemaker's performance will be reduced. Check the filters at least twice a month. When clogged, use warm water and a neutral cleaner to wash the filters.

#### **4. Condenser (air-cooled and remote air-cooled models) - Performed by Qualified Service Technician**

The condenser should be checked and cleaned once a year. Instructions for the service technician can be found in the Installation Manual supplied with this icemaker.

## C. Preparing the Icemaker for Long Storage Performed by Qualified Service Technician

### **⚠ CAUTION**

1. When storing the icemaker for an extended time or in sub-freezing temperatures, follow the instructions below to prevent damage.
2. To prevent damage to the water pump seal, do not operate the icemaker with the control switch in the "WASH" position when the water tank is empty.

When the icemaker is not used for two or three days under normal conditions, it is sufficient to move the control switch to the "OFF" position. When storing the icemaker for an extended time or in sub-freezing temperatures, follow the instructions below.

#### **1. Remove the water from the icemaker water supply line:**

- 1) Turn off the power supply, then remove the front panel.
- 2) Move the control switch on the control box to the "OFF" position.

- 3) Close the icemaker water supply line shut-off valve, then open the icemaker water supply line drain valve.
- 4) Allow the line to drain by gravity.
- 5) Attach a compressed air or carbon dioxide supply to the icemaker water supply line drain valve.
- 6) Move the control switch to the "ICE" position.
- 7) Replace the front panel in its correct position, then turn on the power supply.
- 8) Blow the icemaker water supply line out using the compressed air or carbon dioxide supply.
- 9) Close the icemaker water supply line drain valve.

## **2. Drain the water tank:**

- 1) Turn off the power supply, then remove the front panel. Move the control switch to the "OFF" position.
- 2) Remove the insulation panel. Remove the drain plug located on the lower front part of the ice chute. See Fig. 5. Allow the water tank to drain.
- 3) Replace the drain plug and the insulation panel in their correct positions. Be careful not to cross thread the drain plug.
- 4) Remove all ice from the storage bin. Clean the storage bin using a neutral cleaner. Rinse thoroughly after cleaning.
- 5) Replace the front panel in its correct position.

## **3. On water-cooled model, remove the water from the water-cooled condenser:**

- 1) Make sure the power supply is off, then remove the front panel and right side panel.
- 2) Close the condenser water supply line shut-off valve. If connected to a closed loop system, also close the condenser return line shut-off valve.
- 3) Open the condenser water supply line drain valve. If connected to a closed loop system, also open the condenser return line drain valve.
- 4) Attach a compressed air or carbon dioxide supply to the condenser water supply line drain valve.
- 5) Open the water regulating valve by using a screwdriver to pry up on the spring retainer underneath the spring. While holding the valve open, blow out the condenser using the compressed air or carbon dioxide supply until water stops coming out.
- 6) Close the drain valve(s).