

Hoshizaki America, Inc.

Modular Crescent Cuber

Models

KM-I400SWH/3-M



“A Superior Degree
of Reliability”

www.hoshizaki.com

INSTRUCTION MANUAL



Issued: 5-26-2010

IMPORTANT

Only qualified service technicians should install, service, and maintain the icemaker. No installation, service, or maintenance should be undertaken until the technician has thoroughly read this Instruction Manual. Likewise, the owner/manager should not proceed to operate the icemaker until the installer has instructed them on its proper operation. Failure to install, operate, and maintain the equipment in accordance with this manual may adversely affect safety, performance, component life, and warranty coverage.

Hoshizaki provides this manual primarily to assist qualified service technicians in the installation, maintenance, and service of the icemaker.

Should the reader have any questions or concerns which have not been satisfactorily addressed, please call, write, or send an e-mail message to the Hoshizaki Technical Support Department for assistance.

HOSHIZAKI AMERICA, INC.
618 Highway 74 South
Peachtree City, GA 30269

Attn: Hoshizaki Technical Support Department

Phone: 1-800-233-1940 Technical Support
(770) 487-2331

Fax: 1-800-843-1056
(770) 487-3360

E-mail: techsupport@hoshizaki.com

Web Site: www.hoshizaki.com

NOTE: To expedite assistance, all correspondence/communication **MUST** include the following information:

- Model Number _____
- Serial Number _____
- Complete and detailed explanation of the problem.

IMPORTANT

This manual should be read carefully before the icemaker is installed and operated. Only qualified service technicians should install, service, and maintain the icemaker. Read the warnings contained in this booklet carefully as they give important information regarding safety. Please retain this booklet for any further reference that may be necessary.

CONTENTS

Important Safety Information	4
I. Specifications.....	5
A. Nameplate Rating	5
1. KM-1400SWH-M (water-cooled marine)	5
2. KM-1400SWH3-M (water-cooled marine).....	6
B. Dimensions/Connections	7
II. Installation and Operating Instructions	8
A. Checks Before Installation.....	8
B. How to Remove Panels	8
C. Location	9
D. Setup.....	9
E. Installation of Second Unit	11
F. Electrical Connection	13
G. Water Supply and Drain Connections	14
1. Icemaker	14
2. Water-Cooled Condenser.....	15
a) Connection to an Open Drain System	15
b) Connection to a Closed Loop System	16
H. Final Checklist.....	17
I. Startup.....	18
III. Cleaning and Maintenance	19
A. Cleaning & Sanitizing Instructions.....	19
1. Cleaning Procedure.....	20
2. Sanitizing Procedure - Following Cleaning Procedure	21
B. Maintenance.....	22
C. Preparing the Icemaker for Long Storage	22

Important Safety Information

Throughout this manual, notices appear to bring your attention to situations which could result in death, serious injury, or damage to the unit.

⚠ WARNING Indicates a hazardous situation which could result in death or serious injury.

CAUTION Indicates a situation which could result in damage to the unit.

IMPORTANT Indicates important information about the use and care of the unit.

⚠ WARNING

This icemaker should be destined only to the use for which it has been expressly conceived. Any other use should be considered improper and therefore dangerous. The manufacturer cannot be held responsible for eventual damage caused by improper, incorrect, and unreasonable use.

To reduce the risk of death, electric shock, serious injury, or fire, follow basic precautions including the following:

- Electrical connection must be hard-wired and must meet international, national, state, and local electrical code requirements. Failure to meet these code requirements could result in death, electric shock, serious injury, fire, or severe damage to equipment.
- This unit requires an independent power supply. See the nameplate for proper voltage and breaker/fuse size. Failure to use a proper breaker or fuse can result in a tripped breaker, blown fuse, or damage to existing wiring. This could lead to heat generation or fire.
- **THIS UNIT MUST BE GROUNDED.** Failure to properly ground this unit could result in death or serious injury.
- This unit should be disassembled or repaired only by qualified service personnel to reduce the risk of electric shock, injury, or fire.
- Do not make any alterations to the unit. Alterations could result in electric shock, injury, fire, or damage to the unit.

I. Specifications

A. Nameplate Rating

1. KM-1400SWH-M (water-cooled marine)

HOSHIZAKI ICE MAKER	
MODEL NUMBER	KM-1400SWH-M
SERIAL NUMBER	
AC SUPPLY VOLTAGE	208-230/60/1 (2 WIRE)
COMPRESSOR	208-230V 8.2RLA 56LRA
PUMP	120V 1.2FLA 60W
FAN	--- --- ---
OTHER	115-120V 0.3A
MAXIMUM FUSE SIZE	15 AMPS
MAX. HACR BREAKER (USA ONLY)	15 AMPS
MAX. CIRC. BREAKER (CANADA ONLY)	15 AMPS
MINIMUM CIRCUIT AMPACITY	15 AMPS
DESIGN PRESSURE	HI-427PSI LO-230PSI
REFRIGERANT	404A 2 LB. 2.4 OZ.

**MOTOR-COMPRESSOR THERMALLY PROTECTED,
NOT INTENDED FOR OUTDOOR USE!**

Hoshizaki America, Inc.
Peachtree City, GA
www.hoshizaki.com

 **UL** LISTED
MARINE
ICE MAKER
WITHOUT
STORAGE
MEANS
45FE

 **NSF**
COMPONENT

See the nameplate for electrical and refrigeration specifications. This nameplate is located on the rear panel.

Since this nameplate is located on the rear panel of the icemaker, it cannot be read when the back of the icemaker is against a wall or against another piece of kitchen equipment. Therefore, the necessary electrical and refrigeration information is also on the rating label, which can be easily seen by removing only the front panel of the icemaker.

We reserve the right to make changes in specifications and design without prior notice.

2. KM-1400SWH3-M (water-cooled marine)

HOSHIZAKI ICE MAKER	
MODEL NUMBER	KM-1400SWH3-M
SERIAL NUMBER	
AC SUPPLY VOLTAGE	208-230/60/3
COMPRESSOR	208-230V 5.7RLA 51LRA
PUMP	120V 1.2FLA 60W
FAN	---
OTHER	115-120V 0.3A
MAXIMUM FUSE SIZE	15 AMPS
MAX. HACR BREAKER (USA ONLY)	15 AMPS
MAX. CIRC. BREAKER (CANADA ONLY)	15 AMPS
MINIMUM CIRCUIT AMPACITY	15 AMPS
DESIGN PRESSURE	HI-427PSI LO-230PSI
REFRIGERANT	404A 2 LB. 2.4 OZ.

**MOTOR-COMPRESSOR THERMALLY PROTECTED,
NOT INTENDED FOR OUTDOOR USE!**

Hoshizaki America, Inc.
Peachtree City, GA
www.hoshizaki.com

 **UL** LISTED
MARINE
ICE MAKER
WITHOUT
STORAGE
MEANS
45FE

 **NSF**
COMPONENT

See the nameplate for electrical and refrigeration specifications. This nameplate is located on the rear panel.

Since this nameplate is located on the rear panel of the icemaker, it cannot be read when the back of the icemaker is against a wall or against another piece of kitchen equipment. Therefore, the necessary electrical and refrigeration information is also on the rating label, which can be easily seen by removing only the front panel of the icemaker.

We reserve the right to make changes in specifications and design without prior notice.

B. Dimensions/Connections

1. KM-1400SWH/3-M (water-cooled marine)

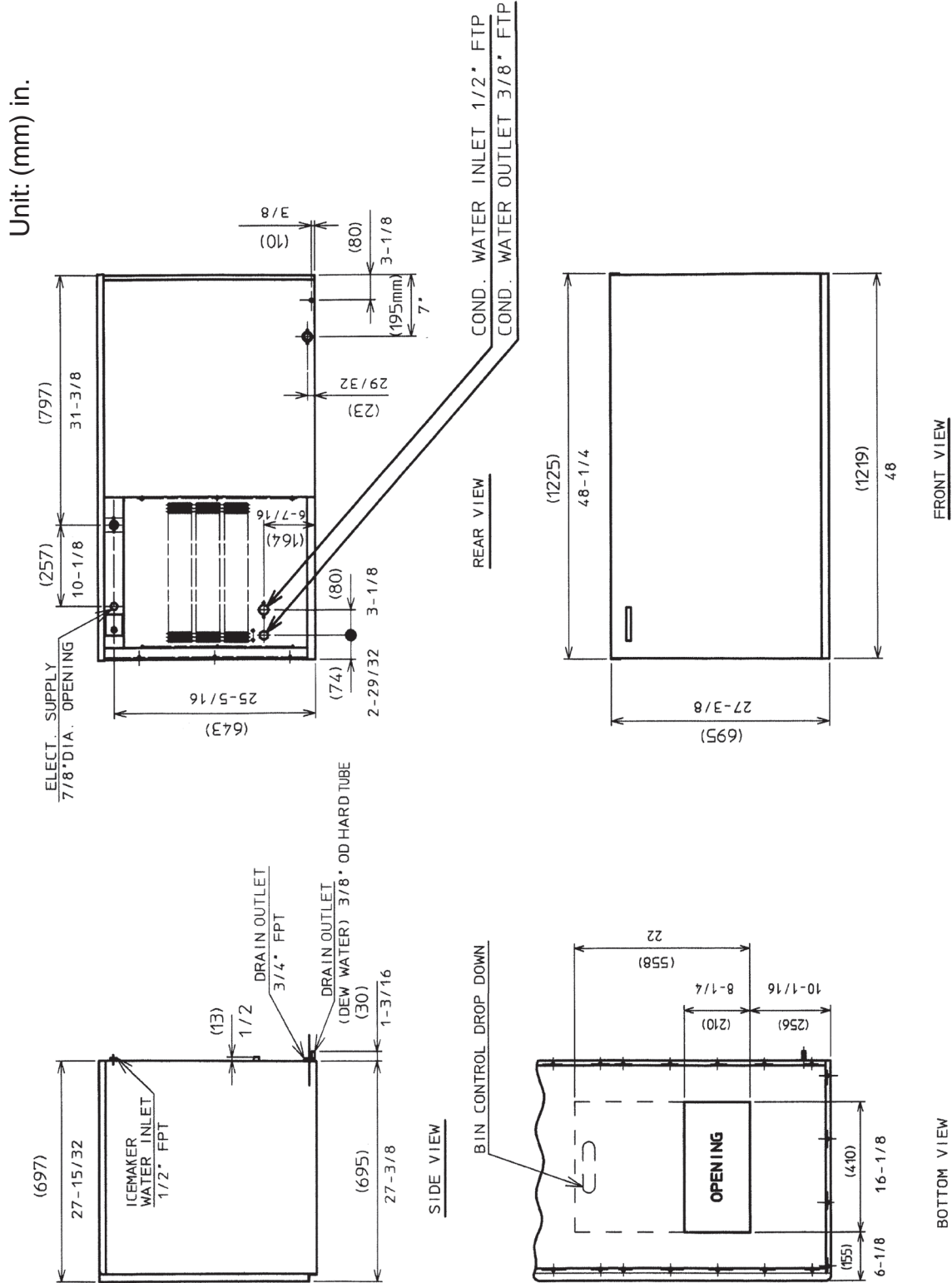

Note: When used with a storage bin not recommended by Hoshizaki, the icemaker needs the space at the bottom opening as in the illustration.

II. Installation and Operating Instructions

⚠ WARNING

1. This icemaker must be installed in accordance with applicable international, national, state, and local regulations.
2. **CHOKING HAZARD:** Ensure all components, fasteners, and thumbscrews are securely in place after installation. Make sure that none have fallen into the storage bin.

A. Checks Before Installation

- Visually inspect the exterior of the shipping container and immediately report any damage to the carrier. Upon opening the container, any concealed damage should also be immediately reported to the carrier.
- Remove the shipping carton, tape, and packing material. If any are left in the icemaker, it will not work properly.
- Remove the panels to prevent damage when installing the icemaker. See "II.B. How to Remove Panels."
- Remove the package containing the accessories.
- Remove the protective plastic film from the panels. If the icemaker is exposed to the sun or to heat, remove the film after the icemaker cools.
- Check that the refrigerant lines do not rub or touch lines or other surfaces.
- Check that the compressor is snug on all mounting pads.
- See the nameplate on the rear panel, and check that your voltage supplied corresponds with the voltage specified on the nameplate.
- This icemaker can be installed on a storage bin 48" wide or wider. For options, contact your local Hoshizaki distributor.

B. How to Remove Panels

See Fig. 1

- Front Panel: Remove the 2 screws. Lift up and towards you.
- Top Panel: Remove the 2 screws, and then lift off.
- Side Panel (R): Remove the screw. Slide forward slightly and lift off.
- Insulation Panel: Remove the thumbscrew. Lift up slightly and pull towards you.
- Top Insulation: Lift off.

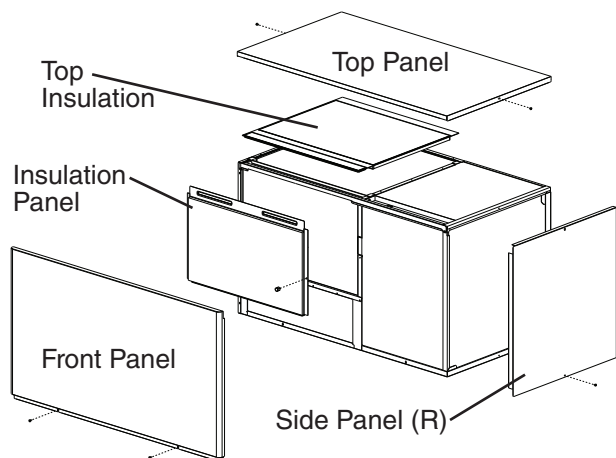

Fig. 1

C. Location

CAUTION

1. This icemaker is not intended for outdoor use. Normal operating ambient temperature should be within 45°F to 100°F (7°C to 38°C); Normal operating water temperature should be within 45°F to 90°F (7°C to 32°C). Operation of the icemaker, for extended periods, outside of these normal temperature ranges may affect icemaker performance.
2. This icemaker will not work at sub-freezing temperatures. To prevent damage to the water supply line, drain the icemaker if the air temperature is going to go below 32°F (0°C). See "III.C. Preparing the Icemaker for Long Storage."

For best operating results:

- The icemaker should not be located next to ovens, grills, or other high heat producing equipment.
- The location should provide a firm and level foundation for the equipment.
- Allow 6" (15 cm) clearance at rear, sides, and top for proper air circulation and ease of maintenance and/or service should they be required.

D. Setup

CAUTION

Before operating the icemaker, the bin control thermostat assembly must be installed correctly. Failure to properly install the assembly could result in ice backup and unit damage.

- 1) Follow the storage bin setup procedure.
- 2) Position the storage bin in the selected permanent location.
- 3) Place the icemaker on top of the storage bin.
- 4) Secure the icemaker to the storage bin using the 2 mounting brackets and the bolts provided. See Fig. 2.

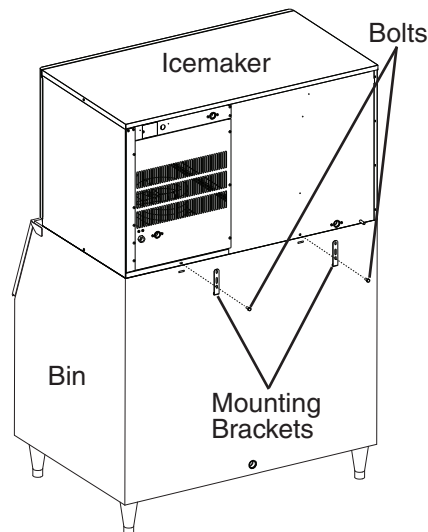
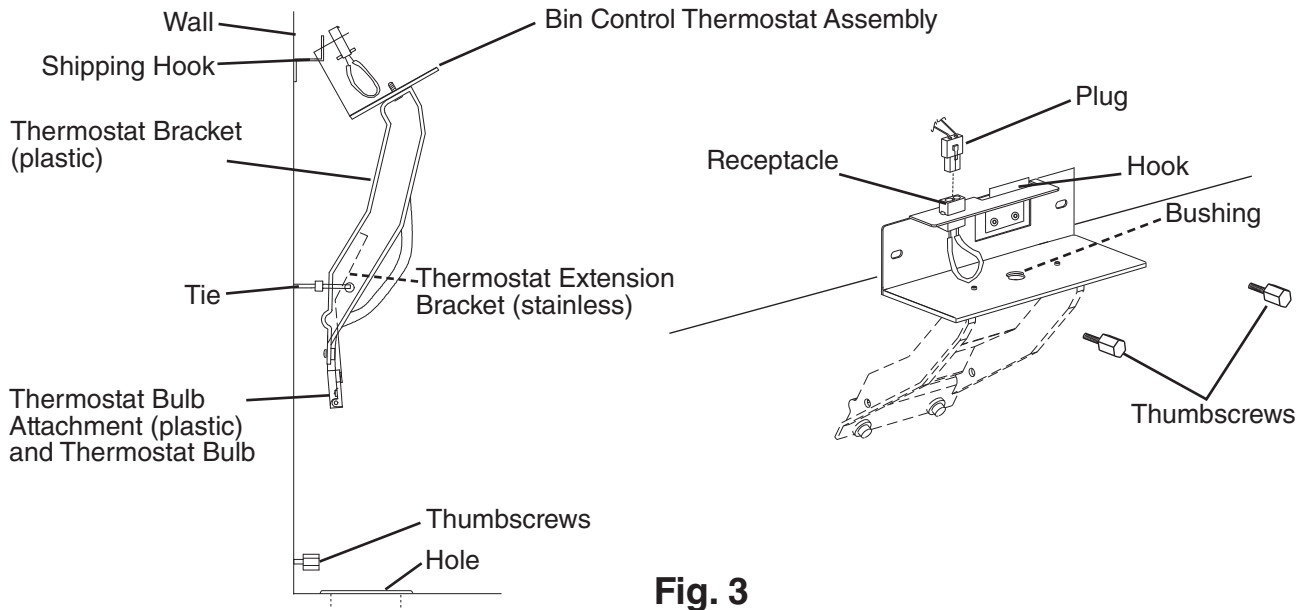
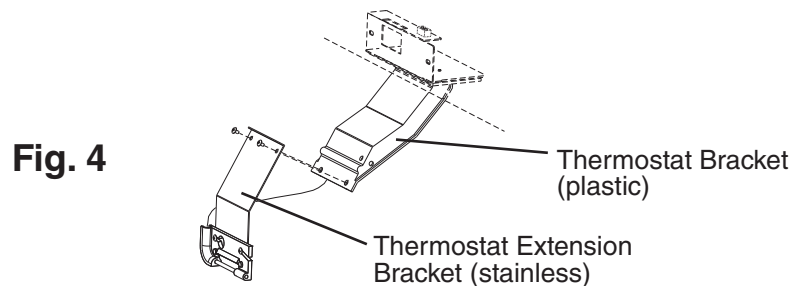

Fig. 2

- 5) Install the bin control thermostat as follows:
 - a. Remove the baffle from the bin.
 - b. Remove the tie securing the bin control thermostat assembly. Remove the 2 thumbscrews.
 - c. Remove the bin control thermostat assembly from the shipping hook by lifting it up and shifting it to the right. Lower the thermostat extension bracket (stainless) with the thermostat bulb attachment and thermostat bulb through the hole located at the bottom of the icemaker. Next, lower the thermostat bracket (plastic) through the hole.



- d. Make sure the left side and bottom of the assembly are flush against the wall and base panel.
- e. Secure the assembly into place with the thumbscrews (unless you are installing a second unit). (See "II.E. Installation of Second Unit.")
- f. Insert the plug into the receptacle on the assembly until it locks into place.
- g. Remove the 2 screws from the lower part of the thermostat bracket (plastic) and use them to attach the thermostat extension bracket (stainless) to the thermostat bracket (plastic).



- 6) Level the icemaker and storage bin in both the left-to-right and front-to-rear directions. Adjust the storage bin legs to make the icemaker level.
- 7) Make sure the icemaker and storage bin are properly secured.
- 8) Seal as required by sanitation code.
- 9) Replace the panels and baffle in their correct positions unless you are installing a second unit. If installing a second unit, see "II.E. Installation of Second Unit."

E. Installation of Second Unit

- 1) See "II.D. Setup" for the lower unit installation.
- 2) Remove the top panel and the top insulation of the lower unit. The top panel and the top insulation of the lower unit are not required when installing the second icemaker.
- 3) Unpack the second icemaker (upper unit), and remove the shipping carton, tape, and packing material.
- 4) Remove the panels of the second icemaker.
- 5) Stack the upper unit on top of the lower unit.
- 6) Secure the upper unit to the lower unit using the 2 mounting brackets and the bolts provided.

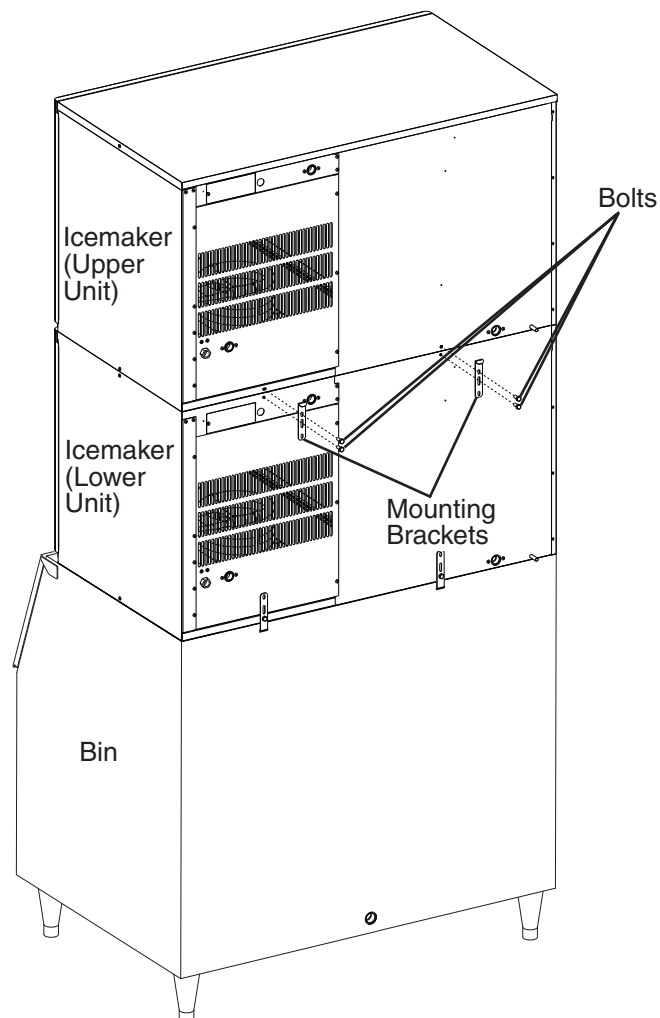

Fig. 5

- 7) Remove the tie securing the upper unit's bin control thermostat assembly.
- 8) Remove the bin control thermostat assembly from the shipping hook by lifting it up and shifting it to the right.
- 9) Remove the thermostat bulb attachment (plastic) of the upper unit from the thermostat extension bracket (stainless).
- 10) Carefully remove the thermostat bulb from the thermostat bulb attachment (plastic) of the upper unit.
- 11) Carefully route the thermostat bulb and capillary tubing of the upper unit through the bottom hole of the upper unit. Remove the bushing from the lower bin control thermostat assembly. Route the bulb and tubing through the hole in the assembly and down into the bin. Reattach the bushing.
- 12) Secure the lower bin control thermostat assembly in place with the thumbscrews.
- 13) Carefully insert the thermostat bulb back into the thermostat bulb attachment (plastic).
- 14) Secure the thermostat bulb attachment (plastic) of the upper unit to the thermostat bulb attachment (plastic) of the lower unit with the screws of the upper unit.
- 15) Insert the plug of the upper unit into the receptacle of the upper unit's bin control thermostat assembly until it locks into place.
- 16) Replace the panels and baffle in their correct positions.

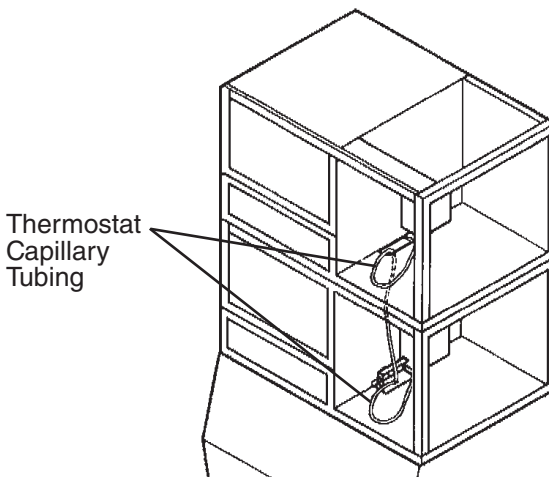

Fig. 6

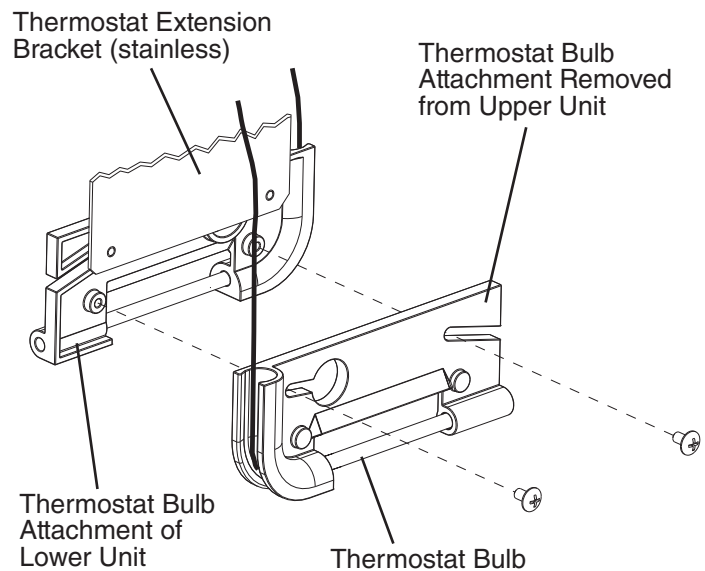

Fig. 7

F. Electrical Connection

⚠ WARNING

1. Electrical connection must be hard-wired and must meet international, national, state, and local electrical code requirements. Failure to meet these code requirements could result in death, electric shock, serious injury, fire, or severe damage to equipment.
2. This unit requires an independent power supply. See the nameplate for proper voltage and breaker/fuse size. Failure to use a proper breaker or fuse can result in a tripped breaker, blown fuses, or damage to existing wiring. This could lead to heat generation or fire.
3. **THIS UNIT MUST BE GROUNDED.** Failure to properly ground this unit could result in death or serious injury.
4. Electrical connection must be made in accordance with the instructions on the "WARNING" tag, provided with the pig tail leads in the junction box. See Fig. 8a and 8b.

- Usually an electrical permit and services of a licensed electrician are required.
- The maximum allowable voltage variation is ± 10 percent of the nameplate rating.
- The transformer's voltage tap switch must be positioned to match incoming voltage at startup.
- **CAUTION! On three phase models, connect the highest incoming voltage supply ("stinger leg") to the red power supply wire (red common wire to the compressor).**
- The opening for the power supply connection is 7/8" DIA to fit a 1/2" trade size conduit.

KM-1400SWH-M

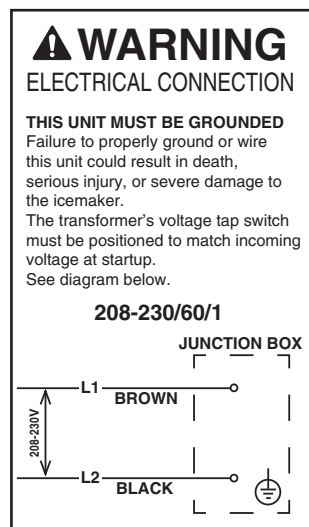

Fig. 8a

KM-1400SWH3-M

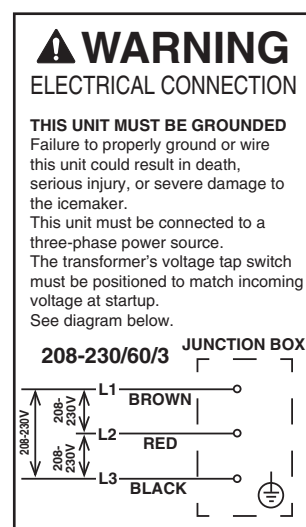

Fig. 8b

G. Water Supply and Drain Connections

See Fig. 9 or 10

WARNING

1. Water supply and drain connections must be installed in accordance with applicable international, national, state, and local regulations.
2. Normal operating water temperature should be within 45°F to 90°F (7°C to 32°C). Operation of the icemaker, for extended periods, outside of this normal temperature range may affect icemaker performance.
3. To prevent damage to equipment, do not operate the icemaker when the water supply is off, or if the pressure is below 10 PSIG. Do not run the icemaker until the proper water pressure is reached.

- A plumbing permit and services of a licensed plumber may be required in some areas.
- External filters, strainers, or softeners may be required depending on water quality. Contact your local Hoshizaki distributor for recommendations.
- Water supply pressure should be a minimum of 10 PSIG and a maximum of 113 PSIG. If the pressure exceeds 113 PSIG, the use of a pressure reducing valve is required.
- The icemaker and condensation drain line(s), storage bin drain line, and water-cooled condenser drain line must be run separately.
- Drain lines must have 1/4" fall per foot (2 cm per 1 m) on horizontal runs to get a good flow. A vented tee connection is also required for proper flow.
- Drain lines should not be piped directly to the sewer system. An air gap of a minimum of 2 vertical inches (5 cm) should be between the end of the drain pipes from the icemaker and condensation drain, storage bin, and water-cooled condenser and the floor drain.

1. Icemaker

- Icemaker water supply inlet is 1/2" female pipe thread (FPT). A minimum of 1/2" nominal copper water tubing is recommended for the icemaker water supply line.
- An icemaker water supply line shut-off valve and drain valve should be installed.
- Icemaker drain outlet is 3/4" FPT. A minimum of 3/4" nominal hard pipe is recommended for the icemaker drain line. Condensation drain outlet is 3/8" OD hard tube. The condensation drain line can be connected to the icemaker drain line or can be run separately.

2. Water-Cooled Condenser

a) Connection to an Open Drain System

- Condenser water supply inlet is 1/2" female pipe thread (FPT). A minimum of 3/8" nominal copper water tubing is recommended for the condenser water supply line.
- A condenser water supply line shut-off valve and drain valve should be installed.
- Condenser drain outlet is 3/8" FPT. A minimum of 3/8" nominal hard pipe is recommended for the condenser drain line.
- In some areas, a back flow preventer may be required in the cooling water circuit.
- In order to maintain the proper high side pressure, the condenser water supply inlet temperature should not drop below 45°F (7°C) and the condenser drain outlet temperature must be in the 104°F to 115°F (40°C to 46°C) range. Once the icemaker installation is complete, confirm the condenser drain outlet temperature 5 minutes after a freeze cycle starts. If the condenser drain outlet temperature is not in the proper range, use a flat blade screwdriver to rotate the adjustment screw on the water-regulating valve until the temperature is in the proper range (rotate counterclockwise to raise temperature or clockwise to lower temperature).

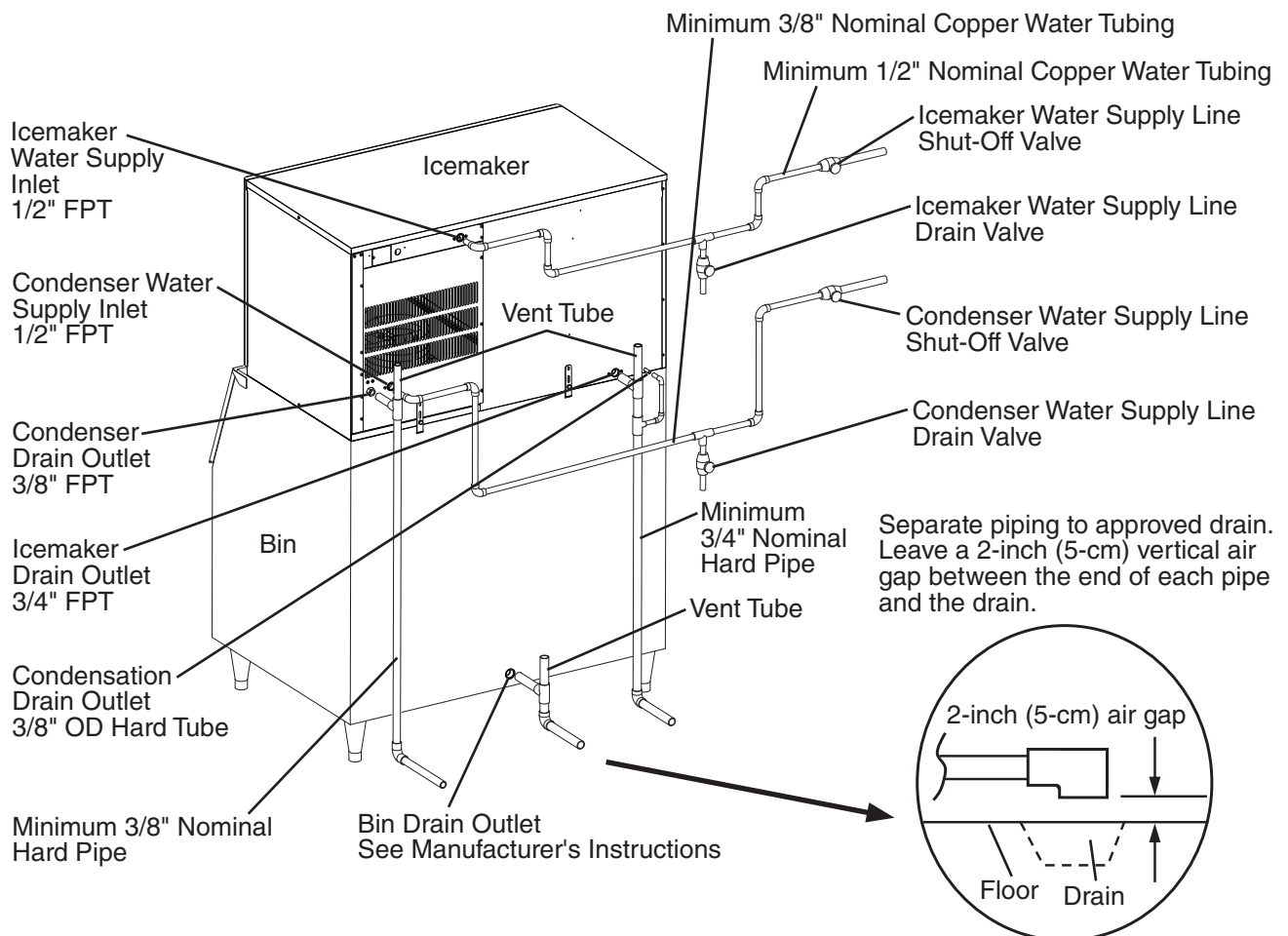

Fig. 9

KM-1400SWH/3-M
Connection to an Open Drain System

b) Connection to a Closed Loop System

- Condenser water supply inlet is 1/2" female pipe thread (FPT). A minimum of 3/8" nominal copper water tubing is recommended for the condenser water supply line.
- Condenser return outlet is 3/8" FPT. A minimum of 3/8" nominal copper water tubing is recommended for the condenser return line.
- Shut-off valves and drain valves should be installed at both the condenser water supply inlet and condenser return outlet.
- The water supply to the condenser should not drop below 4 GPM.
- The pressure differential between the condenser water supply inlet and condenser return outlet must be no less than 10 PSIG.
- When using a glycol blend, the solution mixture should be less than 30% glycol.
- In order to maintain the proper high side pressure, the condenser water supply inlet temperature should not drop below 45°F (7°C) and the condenser return outlet temperature must be in the 104°F to 115°F (40°C to 46°C) range. Once the icemaker installation is complete, confirm the condenser return outlet temperature 5 minutes after a freeze cycle starts. If the condenser return outlet temperature is not in the proper range, use a flat blade screwdriver to rotate the adjustment screw on the water-regulating valve until the temperature is in the proper range (rotate counterclockwise to raise temperature or clockwise to lower temperature).

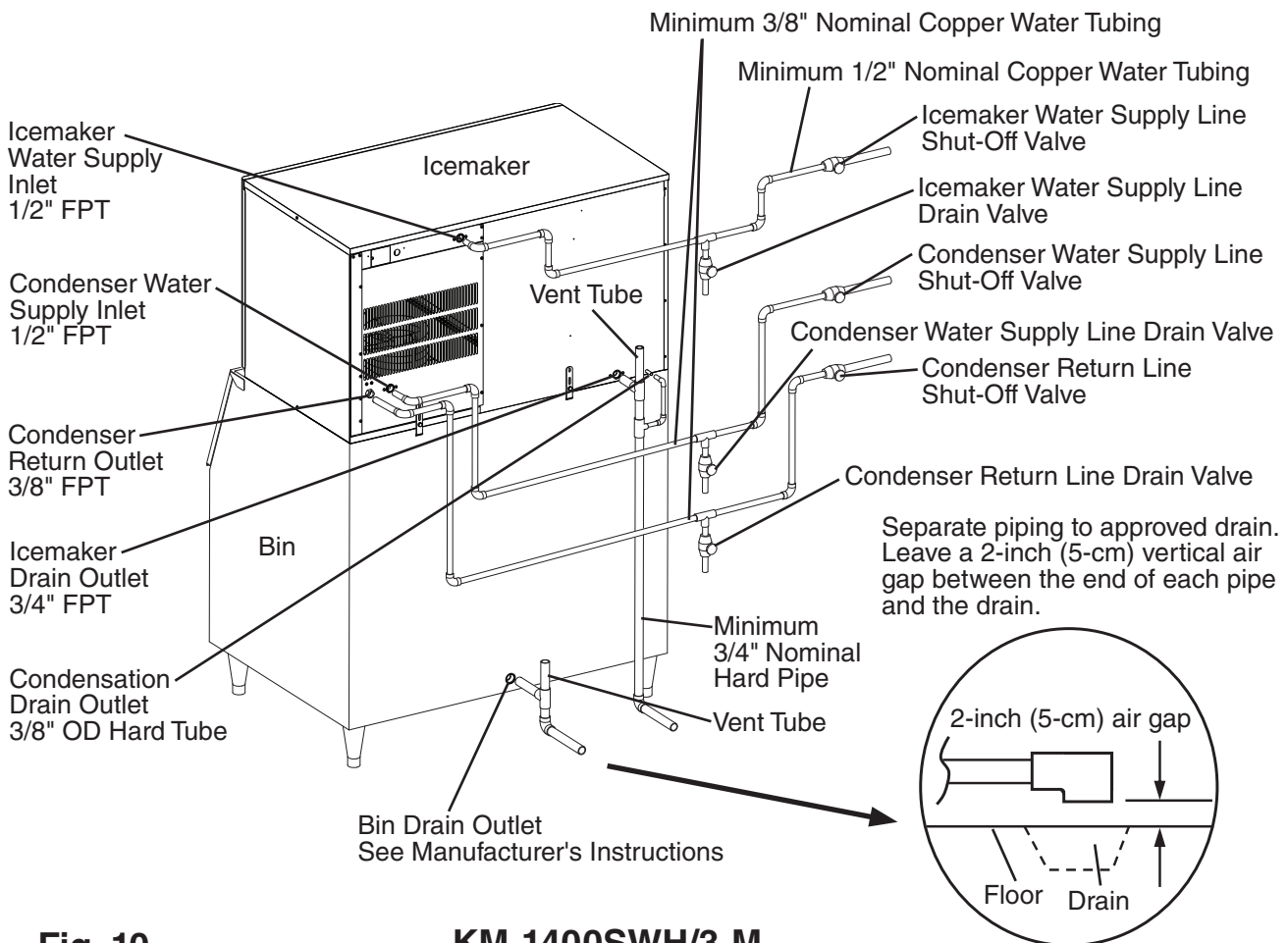

Fig. 10

**KM-1400SWH/3-M
Connection to a Closed Loop System**

H. Final Checklist

WARNING

CHOKING HAZARD: Ensure all components, fasteners, and thumbscrews are securely in place after installation. Make sure that none have fallen into the storage bin.

- 1) Is the icemaker level?
- 2) Is the icemaker in a site where the ambient temperature is within 45°F to 100°F (7°C to 38°C) and the water temperature within 45°F to 90°F (7°C to 32°C) all year around?
- 3) Is there at least 6" (15 cm) clearance at sides, rear, and top of the icemaker for proper air circulation and ease of maintenance and service?
- 4) Have the shipping carton, tape, and packing material been removed from the icemaker? Are the cube guides in their correct positions? Are the separators between the evaporator banks properly attached to their holding clips?
- 5) Are all components, fasteners, and thumbscrews securely in place?
- 6) Have all electrical and water connections been made? Do electrical and water connections meet all international, national, state, and local code and regulation requirements?
- 7) Has the power supply voltage been checked or tested against the nameplate rating? Has a proper ground been installed to the icemaker? Has the transformer's voltage tap switch been positioned to match incoming voltage?
- 8) Are the water supply line shut-off valves and drain valves installed? Has the water supply pressure been checked to ensure a minimum of 10 PSIG and a maximum of 113 PSIG?
Note: The icemaker may stop running when the water supply is off, or if the pressure is below 10 PSIG. When the proper water pressure is reached, the icemaker automatically starts running again.
- 9) Are the compressor hold-down bolts snug? Have the refrigerant lines been checked to make sure they do not rub or touch other lines or surfaces?
- 10) Has the end user been given the instruction manual, and instructed on how to operate the icemaker and the importance of the recommended periodic maintenance?
- 11) Has the end user been given the name and telephone number of an authorized service agent?
- 12) Has the warranty card been filled out and forwarded to the factory for warranty registration?

I. Startup

⚠ WARNING

1. All parts are factory-adjusted. Improper adjustments may adversely affect safety, performance, component life, and warranty coverage.
2. If the icemaker is turned off, wait for at least 3 minutes before restarting the icemaker to prevent damage to the compressor.
3. Do not operate the icemaker in the "WASH" position without water in the water tank. This will cause damage to the water pump seal.
4. At startup, confirm that all internal and external connections are free of leaks.

- 1) Open the water supply line shut-off valves.
- 2) Remove the front panel.
- 3) Move the control switch on the control box to the "ICE" position.
- 4) Replace the front panel in its correct position.
- 5) Turn on the power supply, and allow the icemaker to operate for a total of 10 minutes.
- 6) Turn off the power supply, then remove the front panel.
- 7) Remove the insulation panel. Remove the drain plug located on the lower front part of the ice chute. Allow the water tank to drain. See Fig. 11.
- 8) Replace the drain plug, insulation panel, and front panel in their correct positions. Be careful not to cross thread the drain plug.
- 9) Clean the storage bin liner using a neutral cleaner. Rinse thoroughly after cleaning.
- 10) Turn on the power supply to start the automatic icemaking process.
- 11) When the icemaker is running, hold an ice cube in contact with the bulb. The icemaker should stop within 10 seconds. Adjustment may be needed in some conditions.
- 12) Confirm proper condenser drain outlet/return outlet temperature as outlined in "II.G.2. Water-Cooled Condenser."

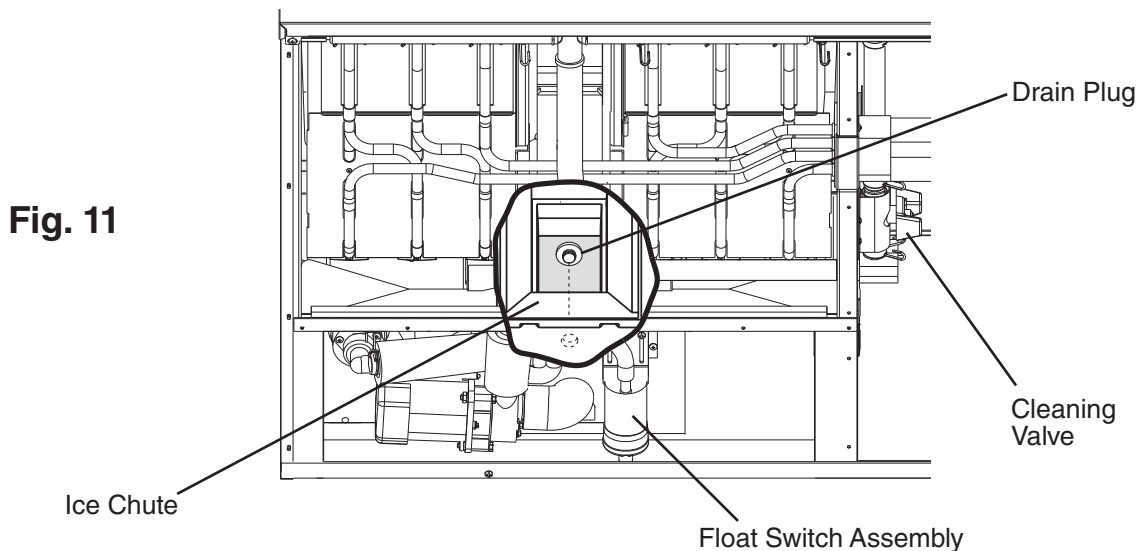

III. Cleaning and Maintenance

This icemaker must be cleaned and maintained in accordance with the instruction manual and labels provided with the icemaker. Consult with your local distributor about cleaning and maintenance service. To obtain the name and phone number of your local distributor, visit www.hoshizaki.com or call Hoshizaki Technical Support at 1-800-233-1940 in the USA.

⚠ WARNING

1. Only qualified service technicians should attempt to service this icemaker.
2. **CHOKING HAZARD:** Ensure all components, fasteners, and thumbscrews are securely in place after any cleaning or maintenance is done to the unit. Make sure that none have fallen into the storage bin.
3. The storage bin is for ice use only. Do not store anything else in the storage bin.

A. Cleaning & Sanitizing Instructions

Hoshizaki recommends cleaning and sanitizing this unit at least once a year. More frequent cleaning and sanitizing, however, may be required in some existing water conditions.

⚠ WARNING

1. To prevent injury to individuals and damage to the icemaker, do not use ammonia type cleaners.
2. Carefully follow any instructions provided with the bottles of cleaning and sanitizing solution.
3. Always wear liquid-proof gloves and goggles to prevent the cleaning and sanitizing solutions from coming into contact with skin or eyes.
4. To prevent damage to the water pump seal, do not operate the icemaker with the control switch in the "WASH" position when the water tank is empty.

IMPORTANT

1. The cleaning valve is opened during cleaning and sanitizing to allow solution flow to the inside of the evaporator. It should be closed for all icemaking operation. The compressor will not operate unless this valve is completely closed.
2. To close the cleaning valve, the valve handle should be at a right angle to the valve body. To open the cleaning valve, the valve handle should be parallel to the valve body.

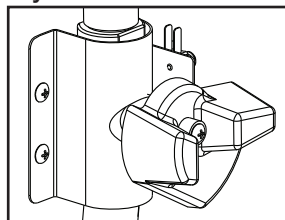

CLOSED

Normal Icemaking Operation

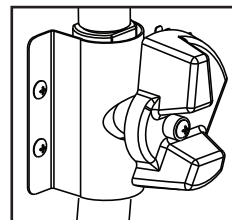

OPEN

Cleaning and Sanitizing Operation
(allows solution flow to the inside of the evaporator)

1. Cleaning Procedure

- 1) Dilute 27 fl. oz. (800 ml) of Hoshizaki "Scale Away" with 5 gal. (19 l) of warm water.
- 2) Remove all ice from the evaporator and the storage bin.
Note: To remove cubes on the evaporator, turn off the power supply and turn it back on after 3 minutes. The harvest cycle starts and the cubes will be removed from the evaporator.
- 3) Turn off the power supply.
- 4) Remove the front panel, then remove the insulation panel by first removing the thumbscrew, lifting up the panel slightly and pulling it towards you.
- 5) Remove the drain plug located on the lower front part of the ice chute. Allow the water tank to drain.
- 6) Replace the drain plug in its correct position. Be careful not to cross thread it.
- 7) In bad or severe water conditions, clean the float switch assembly as described below. Otherwise, continue to step 8.
 - a. Disconnect the vent tube and the flush tube from the top of the float switch, then remove the float switch assembly. Remove the rubber boot from the bottom of the assembly.
 - b. Remove the retainer rod from the bottom of the float switch housing, then remove the float. Be careful not to bend the retainer rod excessively when removing it.
 - c. Wipe down the float switch assembly's housing, shaft, float, and retainer rod with cleaning solution. Clean the inside of the rubber boot and hose with cleaning solution. Rinse the parts thoroughly with clean water.
 - d. Reassemble the float switch assembly and replace it and the rubber boot in their correct positions. Reconnect the vent tube and the flush tube.
- 8) Pour the cleaning solution into the water tank.
- 9) Fully open the cleaning valve on the left side wall of the machine compartment.
- 10) Move the control switch on the control box to the "WASH" position.
- 11) Replace the insulation panel and the front panel in their correct positions.
- 12) Turn on the power supply to start the washing process.
- 13) Turn off the power supply after 30 minutes.
- 14) Remove the front panel and the insulation panel.
- 15) Remove the drain plug. Allow the water tank to drain. Replace the drain plug and the insulation panel in their correct positions.
- 16) Move the control switch to the "ICE" position.
- 17) Close the cleaning valve.
Note: The icemaker will not operate unless the cleaning valve is completely closed.
- 18) Replace the front panel in its correct position.
- 19) Turn on the power supply to fill the water tank with water.
- 20) Turn off the power supply after 3 minutes.
- 21) Remove the front panel and fully open the cleaning valve.

- 22) Move the control switch to the "WASH" position.
- 23) Replace the front panel in its correct position.
- 24) Turn on the power supply to rinse off the cleaning solution.
- 25) Turn off the power supply after 5 minutes.
- 26) Remove the front panel and the insulation panel.
- 27) Remove the drain plug. Allow the water tank to drain. Replace the drain plug and the insulation panel in their correct positions.
Note: Do not replace the insulation panel when you proceed to "2. Sanitizing Procedure."
- 28) Repeat steps 16 through 27 three more times to rinse thoroughly.
Note: If you do not sanitize the icemaker, go to step 9 in "2. Sanitizing Procedure."

2. Sanitizing Procedure - Following Cleaning Procedure

- 1) Dilute 2.5 fl. oz. (74 ml or 5 tbs) of a 5.25% sodium hypochlorite solution (chlorine bleach) with 5 gal. (19 l) of warm water.
- 2) Pour the sanitizing solution into the water tank.
- 3) Replace the insulation panel and the front panel in their correct positions.
Note: Make sure the control switch is in the "WASH" position and the cleaning valve is open.
- 4) Turn on the power supply to start the sanitizing process.
- 5) Turn off the power supply after 15 minutes.
- 6) Remove the front panel and the insulation panel.
- 7) Remove the drain plug. Allow the water tank to drain. Replace the drain plug and the insulation panel in their correct positions.
- 8) Repeat steps 16 through 27 in "1. Cleaning Procedure" two times to rinse thoroughly.
- 9) Close the cleaning valve.
- 10) Move the control switch to the "ICE" position.
- 11) Replace the front panel in its correct position.
- 12) Clean the storage bin liner using a neutral cleaner. Rinse thoroughly after cleaning.
- 13) Turn on the power supply to start the automatic icemaking process.

B. Maintenance

This icemaker must be maintained individually, referring to the instruction manual and labels provided with the icemaker.

WARNING

1. Only qualified service technicians should attempt to service this icemaker.
2. Disconnect power before servicing.

1. Stainless Steel Exterior

To prevent corrosion, wipe the exterior occasionally with a clean, soft cloth. Use a damp cloth containing a neutral cleaner to wipe off oil or dirt buildup.

2. Storage Bin and Scoop

- Wash your hands before removing ice. Use the plastic scoop provided (bin accessory).
- The storage bin is for ice use only. Do not store anything else in the storage bin.
- Clean the scoop and the storage bin liner using a neutral cleaner. Rinse thoroughly after cleaning.

C. Preparing the Icemaker for Long Storage

CAUTION

1. When storing the icemaker for an extended time or in sub-freezing temperatures, follow the instructions below to prevent damage.
2. To prevent damage to the water pump seal, do not operate the icemaker with the control switch in the "WASH" position when the water tank is empty.

When the icemaker is not used for two or three days under normal conditions, it is sufficient to move the control switch to the "OFF" position. When storing the icemaker for an extended time or in sub-freezing temperatures, follow the instructions below.

1. Remove the water from the icemaker water supply line:

- 1) Turn off the power supply, then remove the front panel.
- 2) Move the control switch on the control box to the "OFF" position.
- 3) Close the icemaker water supply line shut-off valve, then open the icemaker water supply line drain valve.
- 4) Allow the line to drain by gravity.
- 5) Attach a compressed air or carbon dioxide supply to the icemaker water supply line drain valve.
- 6) Move the control switch to the "ICE" position.
- 7) Replace the front panel in its correct position, then turn on the power supply.
- 8) Blow the icemaker water supply line out using the compressed air or carbon dioxide supply.
- 9) Close the icemaker water supply line drain valve.

2. Drain the water tank:

- 1) Turn off the power supply, then remove the front panel. Move the control switch to the "OFF" position.
- 2) Remove the insulation panel. Remove the drain plug located on the lower front part of the ice chute. Allow the water tank to drain. See Fig. 11.
- 3) Replace the drain plug and the insulation panel in their correct positions. Be careful not to cross thread the drain plug.
- 4) Remove all ice from the storage bin. Clean the storage bin using a neutral cleaner. Rinse thoroughly after cleaning.
- 5) Replace the front panel in its correct position.

3. Remove the water from the water-cooled condenser:

- 1) Make sure the power supply is off, then remove the front panel, top panel, and right side panel.
- 2) Close the condenser water supply line shut-off valve. If connected to a closed loop system, also close the condenser return line shut-off valve.
- 3) Open the condenser water supply line drain valve. If connected to a closed loop system, also open the condenser return line drain valve.
- 4) Attach a compressed air or carbon dioxide supply to the condenser water supply line drain valve.
- 5) Open the water regulating valve by using a screwdriver to pry up on the spring retainer underneath the spring. While holding the valve open, blow out the condenser using the compressed air or carbon dioxide supply until water stops coming out.
- 6) Close the drain valve(s).
- 7) Replace the right side panel, top panel, and front panel in their correct positions.

HOSHIZAKI AMERICA, INC.

618 Hwy. 74 S., Peachtree City, GA 30269 USA | TEL (770) 487-2331 | FAX (770) 487-3360 | www.hoshizaki.com | 91A7DH10A