

Hoshizaki America, Inc.

Modular Crescent Cuber

Model
KM-650MAH-E



“A Superior Degree
of Reliability”

www.hoshizaki.com

PARTS LIST



Number: 71286
Issued: 8-22-2008
Revised: 8-19-2015

CONTENTS

Auxiliary Codes.....	3
Note About Ordering Parts	3
A. Main Assembly & Refrigeration Circuit	4
B. Water Circuit	6
C. Control Box Assembly	8
D. Accessories & Labels	10

Auxiliary Codes

KM-650MAH-E

T-0 April 2008
U-0 January 2009
U-1 February 2009
V-0 January 2010
V-1 March 2010
V-2 June 2010
A-0 January 2011
A-1 November 2011
B-0 January 2012
C-0 January 2013
C-1 May 2013
D-0 January 2014
D-1 March 2014
E-0 January 2015

Auxiliary Code Breakdown

The auxiliary code is the first two characters in the serial number. The first character indicates the year. Years progress or regress in alphabetical order. The series runs from "A" through "V" and the letters "I" and "O" are skipped. The second character indicates significant part changes within a year. Base is "0" and this number advances for each change. In cases where there is a letter in parentheses, this designates the month. This is the last character in the serial number. The series runs from "(A)" through "(M)" and the letter "(I)" is skipped. This designation is only included when identifying a parts change within an auxiliary code.

Note About Ordering Parts

Most assemblies cannot be ordered as complete units; parts in the assemblies generally must be ordered separately.

IMPORTANT

IEC standards require that the clamping means of earthing terminals be adequately secured against accidental loosening and that accessible metal parts of the icemaker which may become live in the event of an insulation fault be permanently and reliably connected to an earthing terminal within the icemaker or to the earthing contact of the icemaker inlet. This is accomplished in this icemaker through the use of stainless steel lock washers.

A. Main Assembly & Refrigeration Circuit

KM-650MAH-E

T-0 to E-0

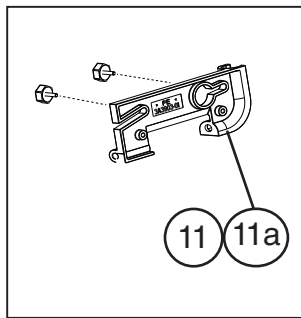
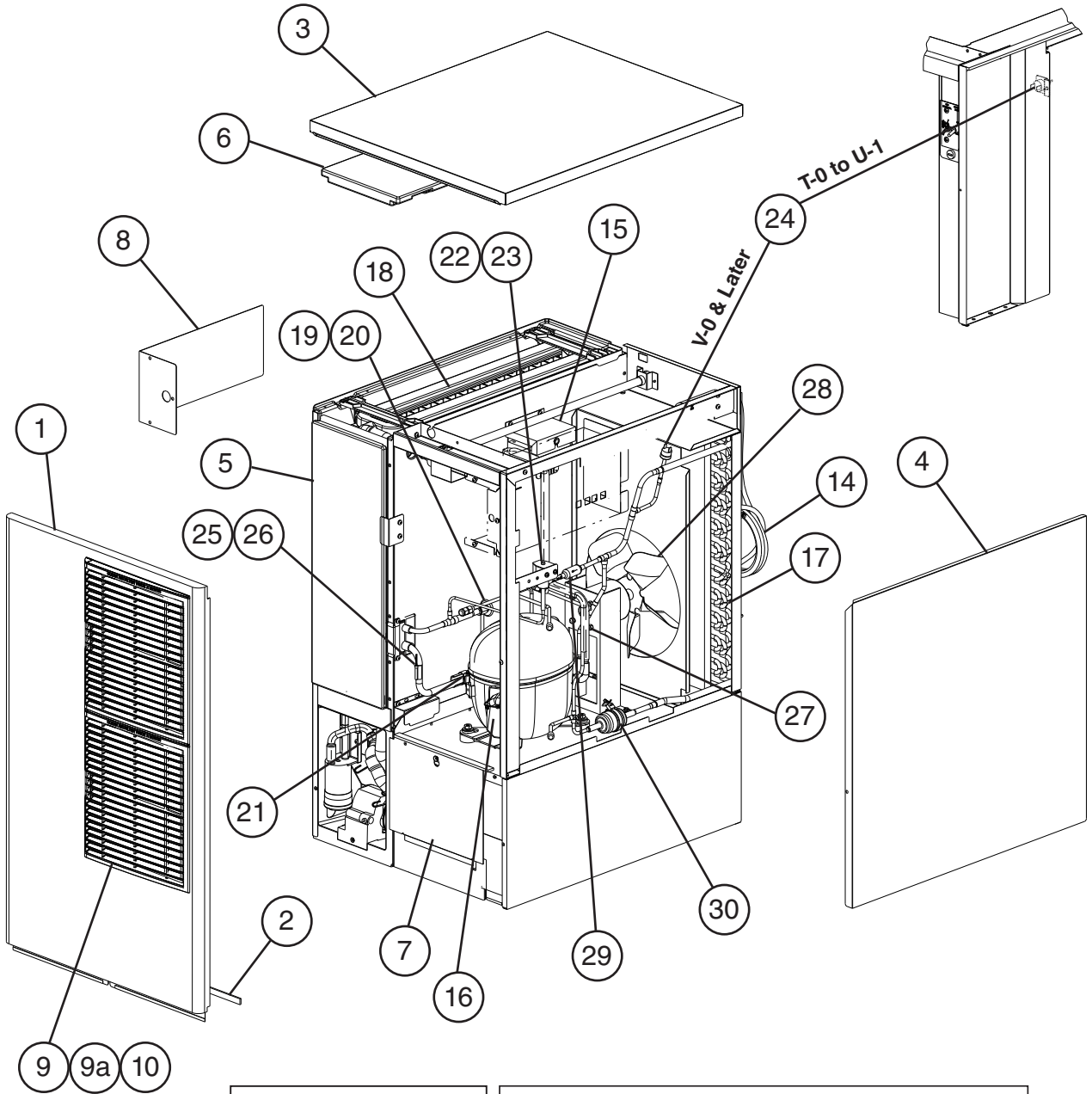

T-0 to U-0

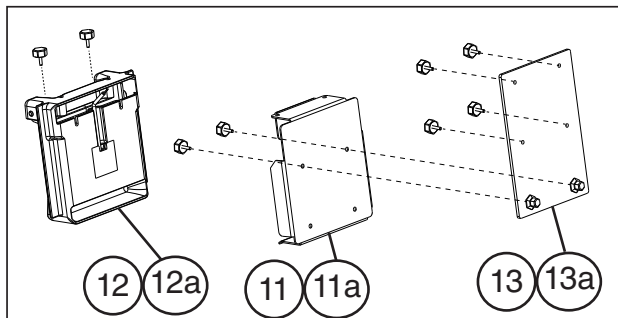

U-1 & Later

Title: A. Main Assenly & Refrigeration Circuit Model: KM-650MAH-E											
Index No.	Description	Material or Model Number	Part Number	Required Number							
				T-0 U-0	U-1	V-0 to C-0	C-1 to E-0				
Main Assembly											
1	Front Panel		2A2243G01	1	1	1	1				
2	Gasket	L=550 mm	4A0808L02	1	1	1	1				
3	Top Panel		3A3878A01	1	1	1	1				
4	Side Panel (R)		2A2117G02	1	1	1	1				
5	Front Insulation		215731G02	1	1	1	1				
6	Top Insulation		215730G01	1	1	1	1				
7	Base Cover		321525G01	1	1	1	1				
8	Control Box Cover		3A2371-01	1	1	1	1				
9	Louver		1A0547-01	2	2	2	2				
9a	Push Retainer		4A2414-01	6	6	6	6				
10	Air Filter		2A2062G01	2	2	2	2				
11	Bulb Holder		3A3903-01	1	-						
	Mechanical Bin Control Switch Mount		3A4463-01		1	1	-				
			3A6040-01					1			
11a	Thumbscrew		415949G11	2	-						
			415949G10		2	2	2				
12	Bin Control		2A4393G01		1	1	1				
12a	Thumbscrew		415949G10		2	2	2				
13	Mechanical bin Control Extension Bracket		4A5046G01		1	1	1				
13a	Thumbscrew		415949G10		4	4	4				
14	Power Supply Cord		452359-02	1	1	1	1				
15	Main Transformer		4A5261-01	1	1	1	1				
Refrigeration Circuit											
16	Compressor		4A4462-01	1	1	1	1				
17	Condenser		2A3853-01	1	1	1	1				
18	Evaporator		106396G01	1	1	1	1				
19	Thermostatic Expansion Valve		4A1482-01	1	1	1	1				
20	Thermostatic Expansion Valve Cover		3A0944-01	1	1	1	1				
21	Thermostatic Expansion Valve Holder		3A0107-01	1	1	1	1				
22	Hot Gas Valve Body		4A3978-01	1	1	1	1				
23	Valve Coil		4A3277-01	1	1	1	1				
24	High-Pressure Switch		433441-07	1	-						
			463180-04		1	1	1				
25	Thermistor		429006-03	1	1	1	1				
26	Thermistor Holder		427430-01	1	1	1	1				
27	Fan Motor		4A3158-01	1	1	1	1				
28	Fan Blade		4A3959-01	1	1	1	1				
29	Strainer		441569-02	1	1	1	1				
30	Drier		4A2666-01	1	1	1	1				

B. Water Circuit
KM-650MAH-E
 T-0 to E-0

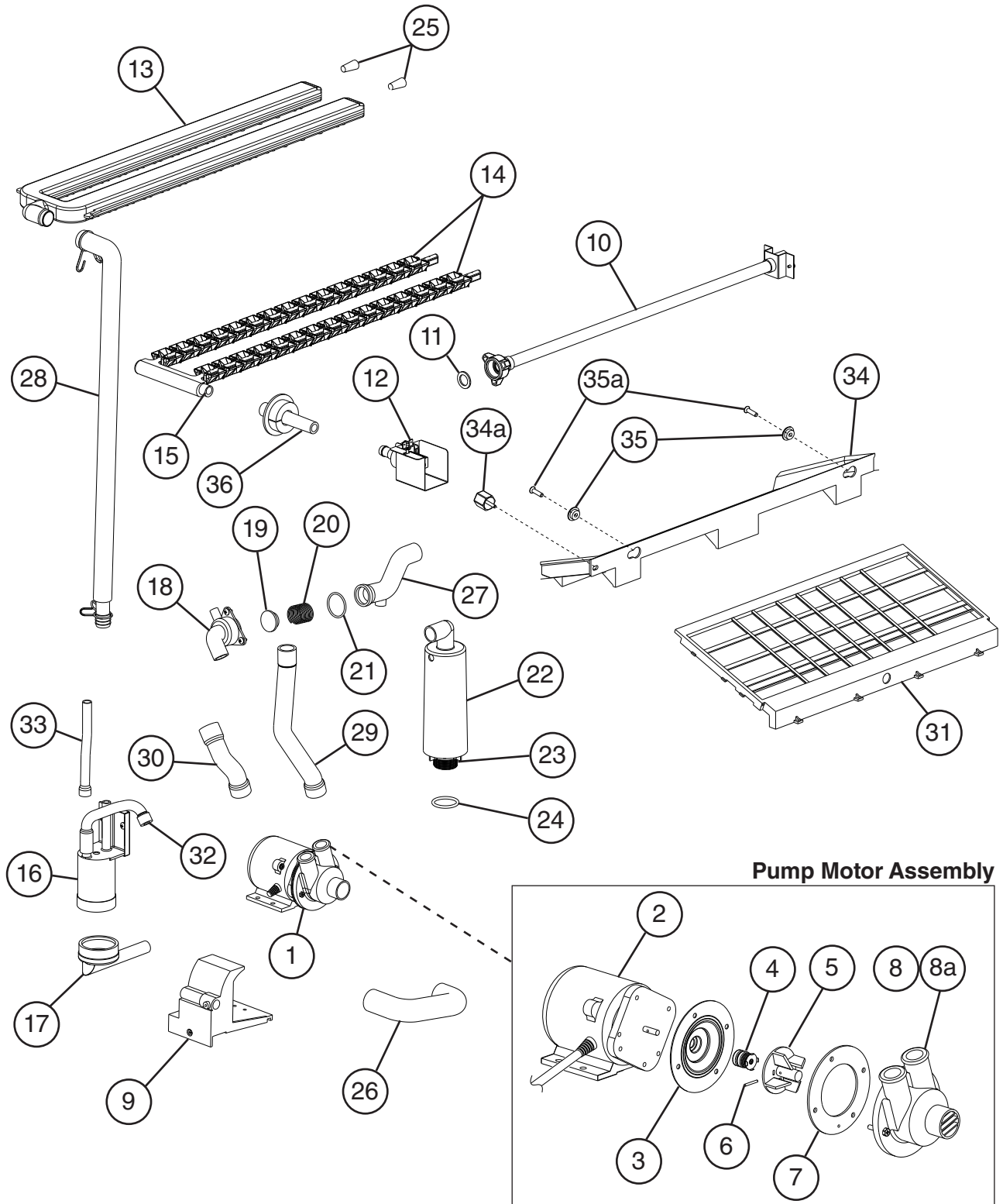

Title: B. Water Circuit Model: KM-650MAH-E

Index No.	Description	Material or Model Number	Part Number	Required Number										
				T-0 to U-1	V-1 to E-0									
1	Pump Motor Assembly (includes items 2 through 8a)		3A2638A02	1	1									
2	Pump Motor		2A2758-01	1	1									
3	Mechanical Seal		465627-01	1	1									
4	Pump Flange		3A2988-01	1	1									
5	Pump Gasket		4A2974-01	1	1									
6	Impeller		417082-01	1	1									
7	Pin		4A0648-01	1	1									
8	Pump Housing		211409-02	1	1									
8a	Screw	4x20	4A3871-01	4	4									
9	Pump Motor Bracket		211408-01	1	1									
10	Water Supply Pipe		4A0768G04	1	-									
			4A5216G04		1									
11	Rubber Gasket		413854-03	1	1									
12	Inlet Water Valve		4A1176-06	1	-									
			4A5251-06		1									
13	Spray Tube		1A0260-02	1	1									
14	Spray Guide (A)		208586-01	6	6									
15	Water Supply Tube		2A0079-01	1	1									
16	Float Switch		4A3624-01	1	1									
17	Float Switch Connector		426799-01	1	1									
18	Drain Valve Housing		321001-01	1	1									
19	Drain Valve Seat		433705-01	1	1									
20	Drain Valve Spring		3A0875-01	1	1									
21	Drain Valve O-Ring		7611-G035	1	1									
22	Overflow Cap		321002-01	1	1									
23	Overflow Pipe		430722-03	1	1									
24	Overflow Pipe O-Ring		4A1234-01	1	1									
25	Stpray Tube Plug		4A0176-01	2	2									
26	Suction Hose		433466-01	1	1									
27	Drain Hose		433468-01	1	1									
28	Rubber Hose		4A1551-01	1	1									
29	Vinyl Hose	L=250 mm	7716-2025	1	1									
30	Vinyl Hose	L=110 mm	7716-2025	1	1									
31	Cube Guide		212088-01	1	1									
32	Silicone Hose	L=140 mm	773013812	1	1									
33	Silicone Hose	L=140 mm	773013896	1	1									
34	Deflector		3A3500-01	1	1									
34a	Thumbscrew		415949G12	1	1									
35	Collar		435269-01	2	2									
35a	Flat Head T2 Screw	4x16	7P22-0416	2	2									
36	Connecting Pipe		4A1142-01	1	1									
	Hose Clamp	16.5 mm	427443-04	1	1									
	Hose Clamp	18 mm	427443-05	1	1									
	Hose Clamp	23 mm	427443-10	2	2									
	Hose Clamp	25 mm	427443-03	4	4									

C. Control Box Assembly
KM-650MAH-E
 T-0 to E-0

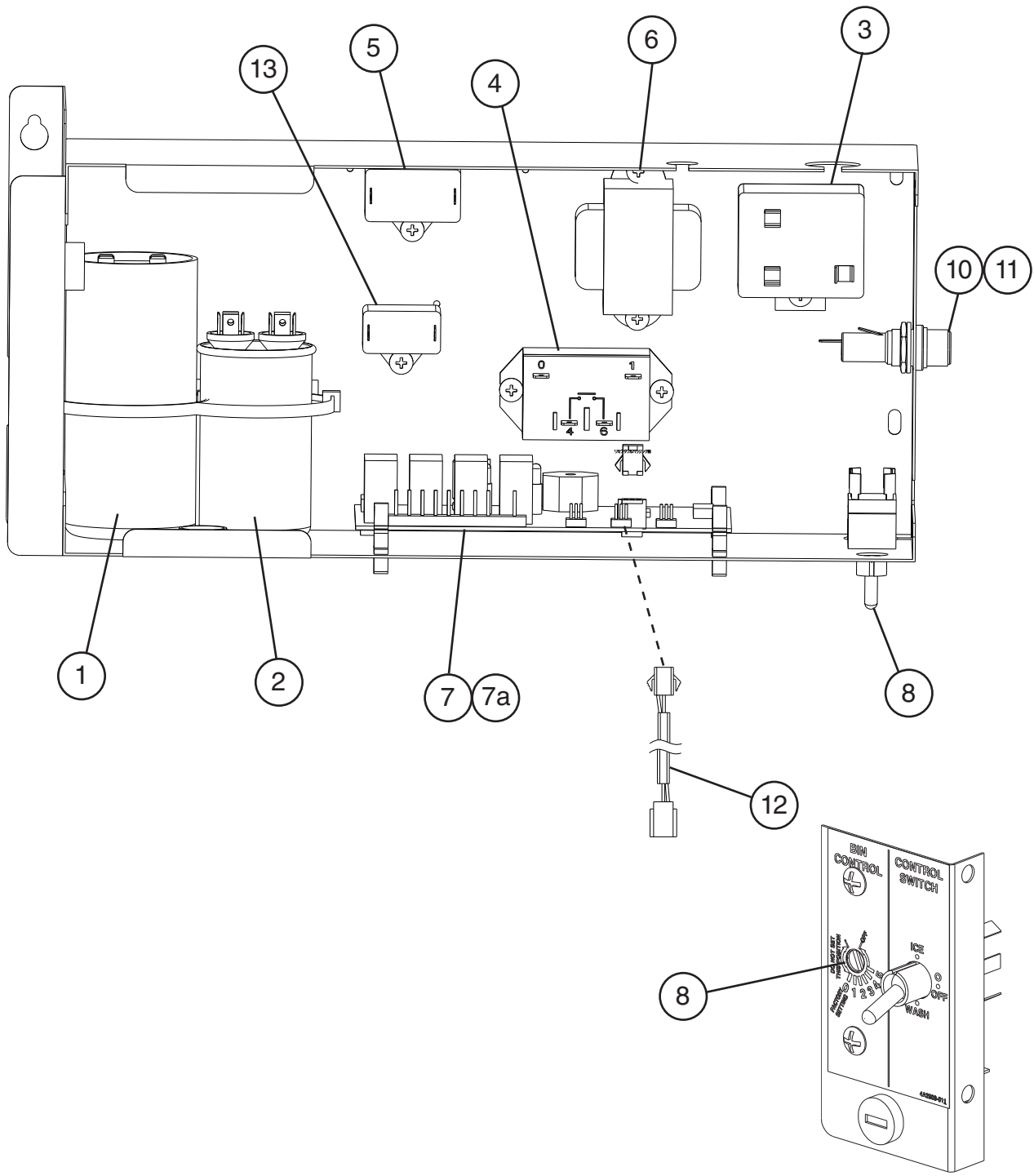

Title: C. Control Box Assembly Model: KM-650MAH-E											
Index No.	Description	Material or Model Number	Part Number	Required Number							
				T-0 U-0	U-1	V-0 V-1	V-2 to E-0				
1	Start Capacitor	130-156MFD, 250VAC	3A4788-01	1	1	1	1				
2	Run Capacitor	20MFD, 440VAC	3A2005-01	1	1	1	1				
3	Start Relay		4A1107-15	1	1	1	1				
4	Magnetic Contactor		428393-01	1	1	1	-				
	Compressor Relay		4A3140-01				1				
5	Pump Motor Capacitor	5.5MFD, 250VAC	4A2128-03	1	1	1	1				
6	Control Transformer		3A0172-01	1	1	1	1				
6a	Control Board	"E" Board	2A1410-01	1	-						
		"G" Board	2A3792-01		1	1	1				
7	Control Board Support		4A0336-03	4	4	4	4				
8	Control Switch		4A2436-01	1	1	1	1				
9	Bin Control		4A2879-01	1	-						
10	Fuse Holder		4A0892-01	1	-						
			4A5443-01		1	1	1				
11	Fuse	AGC-10A, 250VAC	4A0893-07	2	2	2	2				
12	Mechanical Bin Control Wire Harness		4A2200G04		1	1	1				
13	Fan Motor Capacitor	2.5MFD, 250VAC	4A2128-05	1	1	1	1				

D. Accessories & Labels
KM-650MAH-E
 T-0 to E-0

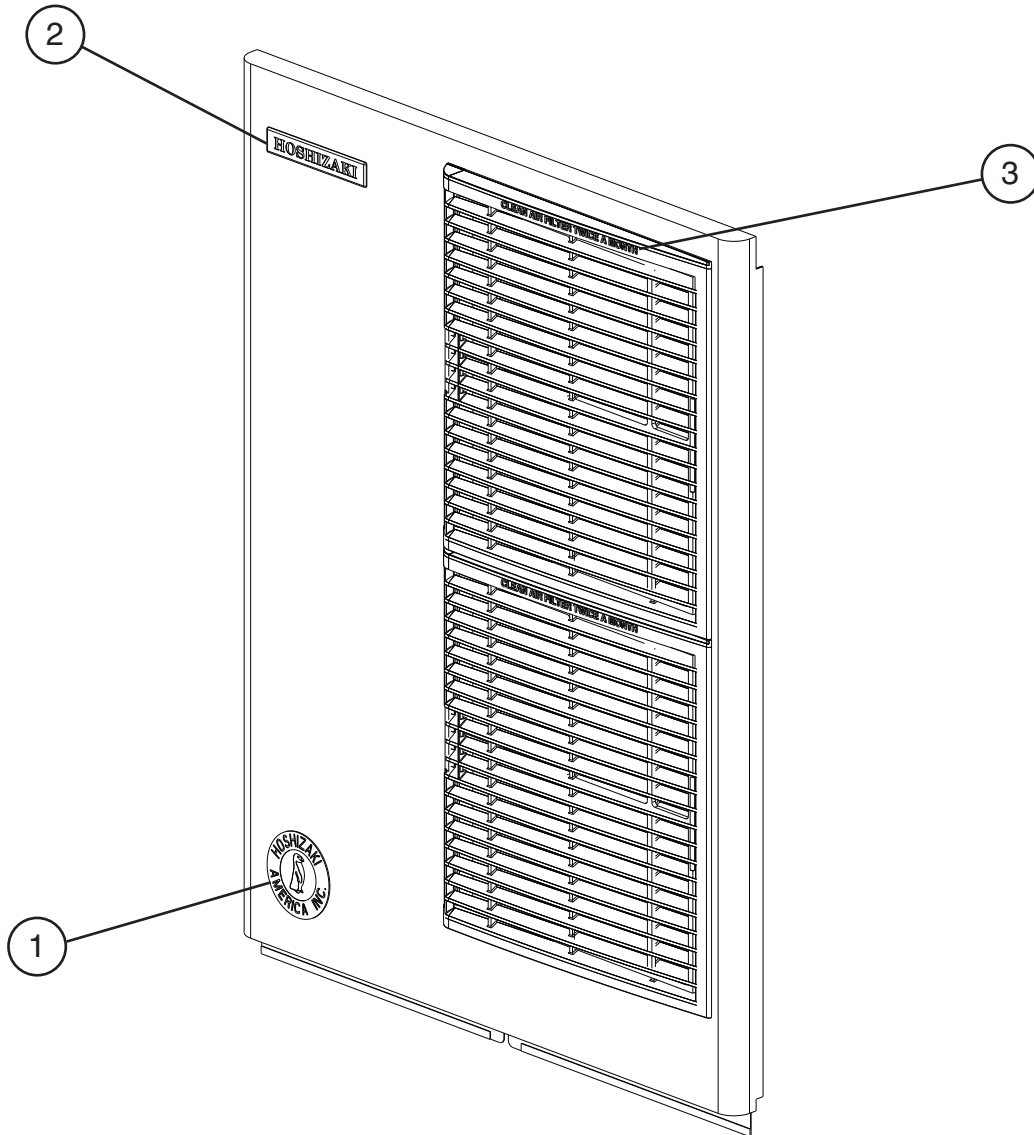

Title: D. Accessories & Labels		Model: KM-650MAH-E		Required Number							
Index No.	Description	Material or Model Number	Part Number	T-0 to D-1 (H)	D-1 to E-0 (J)						
				1	Penguin Label-HA-R		4A0526-01	1	1		
2	Hoshizaki Emblem		4A0560-01	1	1						
3	Air Filter Label		426177-01	1	-						
4	Universal Brace		4A0363-01	2	2						
4a	Hex Head Bolt	5x12, SS	7B02-0512	4	4						