

Hoshizaki America, Inc.

Modular Crescent Cuber

Models

KM-90 IMAH50

KM-90 IMRH50



“A Superior Degree
of Reliability”

www.hoshizaki.com

INSTRUCTION MANUAL



Issued: 6-21-2010

IMPORTANT

Only qualified service technicians should install, service, or maintain this icemaker. No installation, service, or maintenance should be undertaken until the technician has thoroughly read this Instruction Manual. Likewise, the owner/manager should not proceed to operate the icemaker until the installer has instructed them on its proper operation. Failure to install, operate, and maintain the equipment in accordance with this manual may adversely affect safety, performance, component life, and warranty coverage.

Hoshizaki provides this manual primarily to assist qualified service technicians in the installation, maintenance, and service of the icemaker.

Should the reader have any questions or concerns which have not been satisfactorily addressed, please call, write, or send an e-mail message to the Hoshizaki Technical Support Department for assistance.

HOSHIZAKI AMERICA, INC.
618 Highway 74 South
Peachtree City, GA 30269

Attn: Hoshizaki Technical Support Department

Phone: 1-800-233-1940 Technical Support
(770) 487-2331

Fax: 1-800-843-1056
(770) 487-3360

E-mail: techsupport@hoshizaki.com

Web Site: www.hoshizaki.com

NOTE: To expedite assistance, all correspondence/communication MUST include the following information:

- Model Number _____
- Serial Number _____
- Complete and detailed explanation of the problem.

IMPORTANT

This manual should be read carefully before the icemaker is installed and operated. Only qualified service technicians should install, service, and maintain the icemaker. Read the warnings contained in this booklet carefully as they give important information regarding safety. Please retain this booklet for any further reference that may be necessary.

CONTENTS

Important Safety Information	4
I. Specifications.....	5
A. Nameplate Rating	5
1. KM-901MAH50 (air-cooled).....	5
2. KM-901MRH50 (remote air-cooled)	6
B. Dimensions/Connections	7
1. KM-901MAH50.....	7
2. KM-901MRH50	8
II. Installation and Operating Instructions	9
A. Checks Before Installation.....	9
B. How to Remove Panels	9
C. Location	10
D. Setup.....	10
E. Electrical Connection	11
F. Installation of Remote Condenser Unit	12
1. Checks Before Installation.....	12
2. Location	12
3. Setup	13
4. Line Set	13
a) Factory Line Set Installation	13
b) Field Fabricated Line Set Installation.....	14
5. Refrigerant Charge (Line Set Exceeding 66 Feet).....	16
6. Electrical Connection.....	16
7. Stacking Remote Condenser Units	17
G. Water Supply and Drain Connections	18
H. Final Checklist.....	20
I. Startup.....	21
III. Cleaning and Maintenance	22
A. Cleaning and Sanitizing Instructions	22
1. Cleaning Procedure.....	22
2. Sanitizing Procedure - Following Cleaning Procedure	23
B. Maintenance.....	24
C. Preparing the Icemaker for Long Storage	24

Important Safety Information

Throughout this manual, notices appear to bring your attention to situations which could result in death, serious injury, or damage to the unit.

⚠ WARNING Indicates a hazardous situation which could result in death or serious injury.

CAUTION Indicates a situation which could result in damage to the unit.

IMPORTANT Indicates important information about the use and care of the unit.

⚠ WARNING

This icemaker should be destined only to the use for which it has been expressly conceived. Any other use should be considered improper and therefore dangerous. The manufacturer cannot be held responsible for eventual damage caused by improper, incorrect, and unreasonable use.

To reduce the risk of death, electric shock, serious injury, or fire, follow basic precautions including the following:

- Electrical connection must be hard-wired and must meet national, state, and local electrical code requirements. Failure to meet these code requirements could result in death, electric shock, serious injury, fire, or severe damage to equipment.
- This unit requires an independent power supply. See the nameplate for proper voltage and breaker/fuse size. Failure to use a proper breaker or fuse can result in a tripped breaker, blown fuse, or damage to existing wiring. This could lead to heat generation or fire.
- **THIS UNIT MUST BE GROUNDED.** Failure to properly ground this unit could result in death or serious injury.
- This unit should be disassembled or repaired only by qualified service personnel to reduce the risk of electric shock, injury, or fire.
- Do not make any alterations to the unit. Alterations could result in electric shock, injury, fire, or damage to the unit.

I. Specifications

A. Nameplate Rating

1. KM-901MAH50 (air-cooled)

HOSHIZAKI ICE MAKER	
MODEL NUMBER	KM-901MAH50
SERIAL NUMBER	
AC SUPPLY VOLTAGE	230V
FREQUENCY	50HZ
ELECTRICAL CONSUMPTION	2157W
COMPRESSOR CONSUMPTION	1921W
AMPERAGE	9.0A
STARTING AMPERAGE	34A
REFRIGERANT	404A 1375G
WEIGHT	116KG
MAXIMUM OPERATING PRESSURE	2.88MPA
LEAK TIGHTNESS TESTED	

**MOTOR-COMPRESSOR THERMALLY PROTECTED,
NOT INTENDED FOR OUTDOOR USE!**

Hoshizaki America, Inc.
Peachtree City, GA
www.hoshizaki.com

See the nameplate for electrical and refrigeration specifications. This nameplate is located on both the rear panel and inside the icemaker.

We reserve the right to make changes in specifications and design without prior notice.

2. KM-901MRH50 (remote air-cooled)

HOSHIZAKI ICE MAKER

MODEL NUMBER	KM-901MRH50
SERIAL NUMBER	
AC SUPPLY VOLTAGE	230V
FREQUENCY	50HZ
ELECTRICAL CONSUMPTION	2222W
COMPRESSOR CONSUMPTION	1961W
AMPERAGE	9.2A
STARTING AMPERAGE	37A
REFRIGERANT	404A 2420G
WEIGHT	113KG
MAXIMUM OPERATING PRESSURE	2.88MPA
LEAK TIGHTNESS TESTED	

**MOTOR-COMPRESSOR THERMALLY PROTECTED,
NOT INTENDED FOR OUTDOOR USE!**

Hoshizaki America, Inc.
Peachtree City, GA
www.hoshizaki.com

See the nameplate for electrical and refrigeration specifications. This nameplate is located on both the rear panel and inside the icemaker.

We reserve the right to make changes in specifications and design without prior notice.

B. Dimensions/Connections

1. KM-901MAH50

Unit: mm (in.)

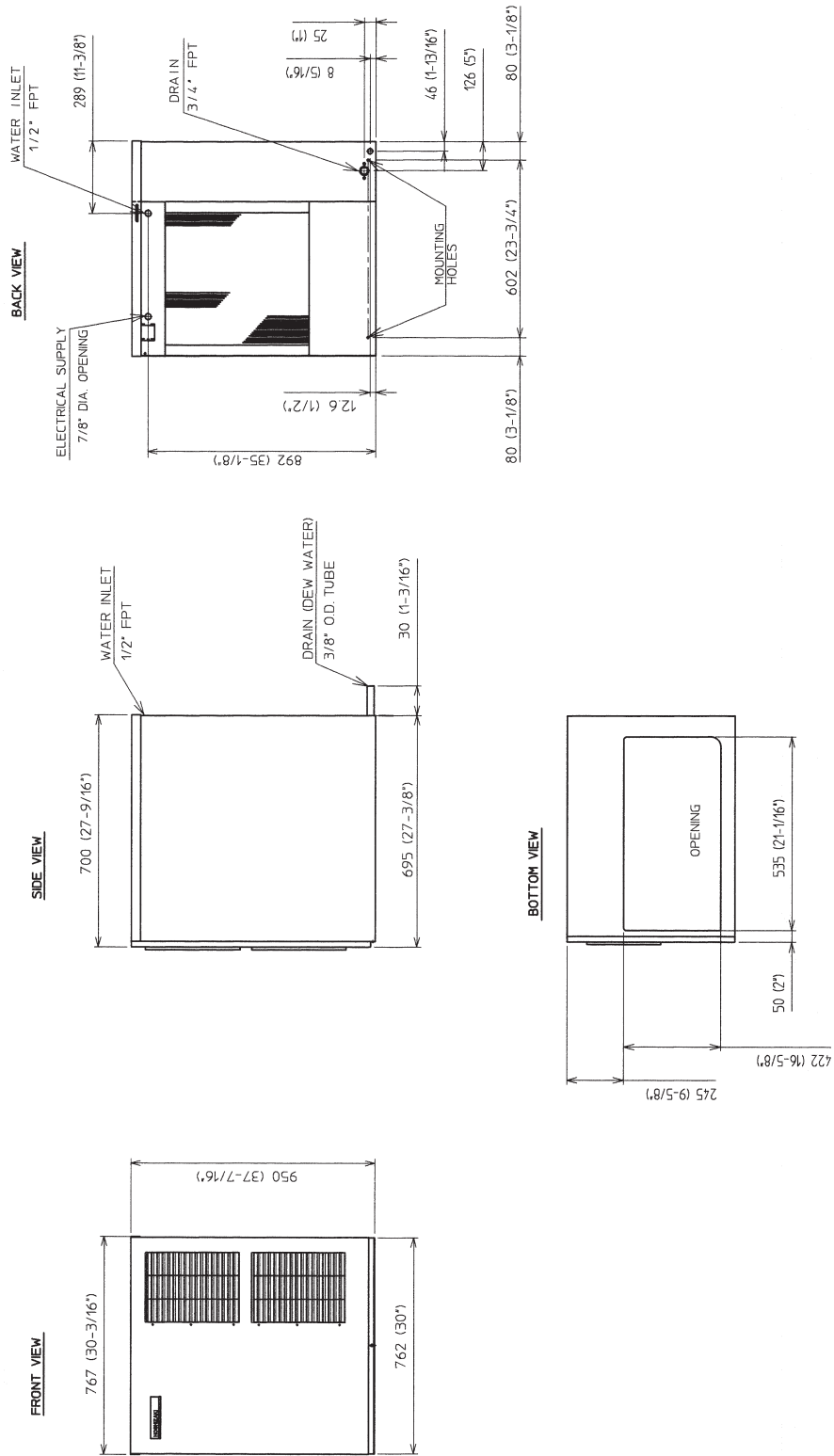

2. KM-901MRH50

Unit: mm (in.)

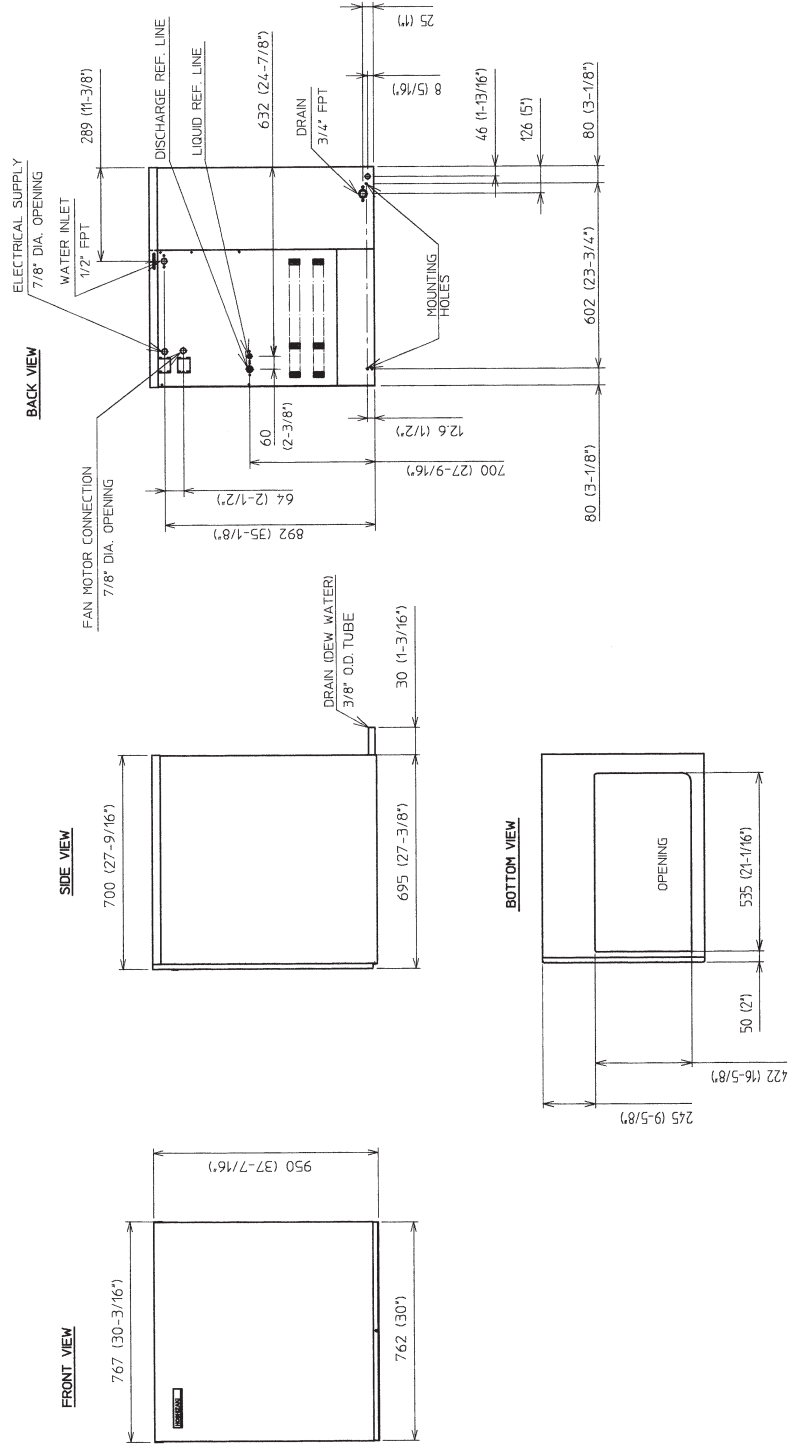

II. Installation and Operating Instructions

⚠ WARNING

1. This icemaker must be installed in accordance with applicable national, state, and local regulations.
2. **CHOKING HAZARD:** Ensure all components, fasteners, and thumbscrews are securely in place after installation. Make sure that none have fallen into the storage bin.

A. Checks Before Installation

- Visually inspect the exterior of the shipping container and immediately report any damage to the carrier. Upon opening the container, any concealed damage should also be immediately reported to the carrier.
- Remove the shipping carton, tape, and packing material. If any are left in the icemaker, it will not work properly.
- Remove the panels to prevent damage when installing the icemaker. See "II.B. How to Remove Panels."
- Remove the package containing the accessories.
- Remove the protective plastic film from the panels. If the icemaker is exposed to the sun or to heat, remove the film after the icemaker cools.
- Check that the refrigerant lines do not rub or touch lines or other surfaces, and that the fan blade (if applicable) turns freely.
- Check that the compressor is snug on all mounting pads.
- See the nameplate on the rear panel, and check that your voltage supplied corresponds with the voltage specified on the nameplate.
- This icemaker can be installed on a storage bin 30" wide or wider. Hoshizaki Ice Storage Bin, Model B-500 series is recommended. For further options, contact your local Hoshizaki distributor.
- On remote air-cooled model, a remote condenser unit is needed. Hoshizaki Remote Condenser Unit, Model URC-9F is recommended.

B. How to Remove Panels

See Fig. 1

- Front Panel: Remove the screw. Lift up and towards you.
- Top Panel: Lift up at front slightly, push rearward, and lift off.
- Side Panel (R): Remove the screw. Slide forward slightly, and lift off.
- Insulation Panel: Lift up slightly, and pull towards you.
- Base Cover: Lift up slightly, and pull towards you.

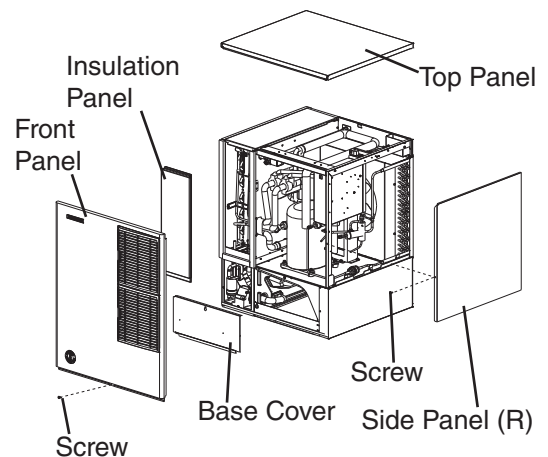

Fig. 1

C. Location

CAUTION

1. This icemaker is not intended for outdoor use. Normal operating ambient temperature should be within 45°F to 100°F (7°C to 38°C); Normal operating water temperature should be within 45°F to 90°F (7°C to 32°C). Operation of the icemaker, for extended periods, outside of these normal temperature ranges may affect icemaker performance.
2. This icemaker will not work at sub-freezing temperatures. To prevent damage to the water supply line, drain the icemaker if the air temperature is going to go below 32°F (0°C). See "III.C. Preparing the Icemaker for Long Storage."

For best operating results:

- The icemaker should not be located next to ovens, grills, or other high heat producing equipment.
- The location should provide a firm and level foundation for the equipment.
- Allow 6" (15 cm) clearance at rear, sides, and top for proper air circulation and ease of maintenance and/or service should they be required.

D. Setup

- 1) Unpack the storage bin, and attach the 4 adjustable legs provided (bin accessory) to the bottom of the storage bin.
- 2) Position the storage bin in the selected permanent location.
- 3) Place the icemaker on top of the storage bin.
- 4) Secure the icemaker to the storage bin using the 2 mounting brackets and the bolts provided. See Fig. 2.
- 5) Level the icemaker and storage bin in both the left-to-right and front-to-rear directions. Adjust the storage bin legs to make the icemaker level.
- 6) Replace the panels in their correct positions.

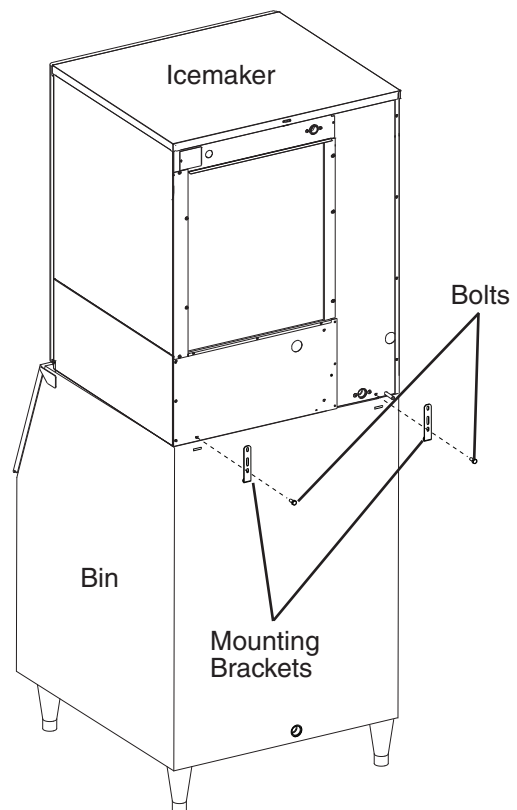

Fig. 2

E. Electrical Connection

⚠ WARNING

For All Models

1. Electrical connection must be hard-wired and must meet national, state, and local electrical code requirements. Failure to meet these code requirements could result in death, electric shock, serious injury, fire, or severe damage to equipment.
2. This unit requires an independent power supply. See the nameplate for proper voltage and breaker/fuse size. Failure to use a proper breaker or fuse can result in a tripped breaker, blown fuses, or damage to existing wiring. This could lead to heat generation or fire.
3. **THIS UNIT MUST BE GROUNDED.** Failure to properly ground this unit could result in death or serious injury.
4. Electrical connection must be made in accordance with the label provided next to the junction box. See Fig. 3.

Additional Warnings for Remote Air-Cooled Model

5. **THE REMOTE CONDENSER UNIT MUST BE GROUNDED.** The power supply and ground wire to the remote condenser unit are supplied from the icemaker. See "II.F.5. Electrical Connection."
6. To reduce the risk of electric shock, make all remote condenser unit connections before connecting the icemaker power supply.
7. On remote air-cooled models, the icemaker should have power for a minimum of 4 hours prior to startup to prevent compressor damage.

- Usually an electrical permit and services of a licensed electrician are required.
- The maximum allowable voltage variation is ± 10 percent of the nameplate rating.
- The opening for the power supply connection is 7/8" DIA to fit a 1/2" trade size conduit.

KM-901MAH50
KM-901MRH50

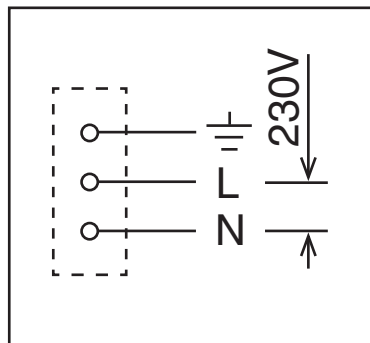

Fig. 3

F. Installation of Remote Condenser Unit

⚠ WARNING

1. Installation of remote condenser unit must be performed by properly trained and certified service personnel.
2. Failure to install the equipment within these guidelines may adversely affect safety, performance, component life, and warranty coverage.

1. Checks Before Installation

- 1) Remove the shipping carton, tape, and packing material.
- 2) Check that the refrigerant lines do not rub or touch lines or other surfaces, and that the fan blade moves freely.

2. Location

⚠ CAUTION

The remote condenser unit is intended for outdoor use. Normal operating ambient temperature should be within -20°F to +122°F (-29°C to +50°C). Operation of the remote condenser unit, for extended periods, outside of this normal temperature range may affect icemaker performance.

The remote condenser unit must be positioned in a permanent site under the following guidelines:

- A firm and flat site.
- A dry and well ventilated area with 24" (61 cm) clearance in both front and rear for proper air circulation and ease of maintenance and/or service should they be required. See Fig. 4.
- The maximum line length for the standard refrigerant charge is 66 feet. With additional refrigerant, the maximum line length is 100 feet. For details, see "II.F.5. Refrigerant Charge (Line Set Exceeding 66 Feet)."
- The maximum vertical distance between the remote condenser unit and the icemaker is 33 feet above or 10 feet below the icemaker. These distances are measured fitting to fitting. See Fig. 5.

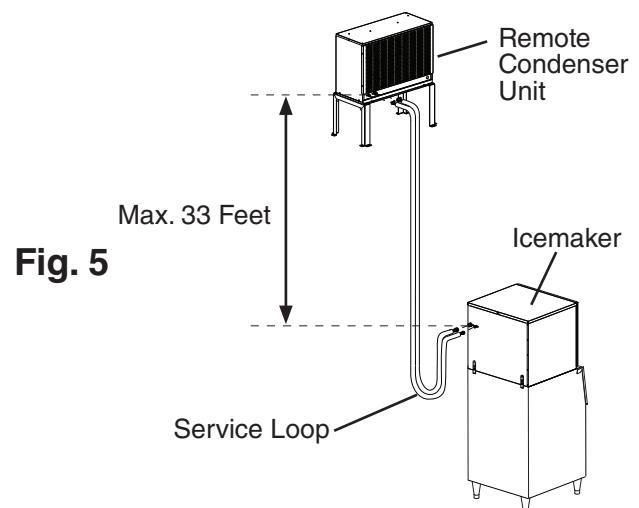
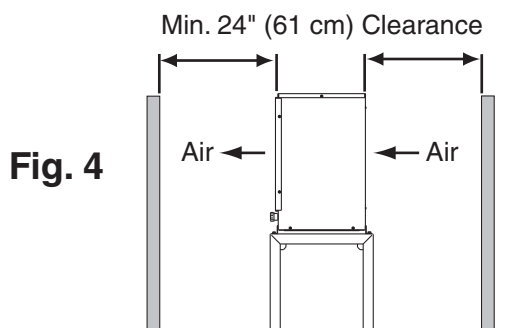

3. Setup

- 1) Secure the legs to the remote condenser unit with the 8 bolts and nuts provided. See Fig. 6.
- 2) The legs have 8 mounting holes. Secure the legs to the permanent site with 8 bolts (not included).

Fig. 6

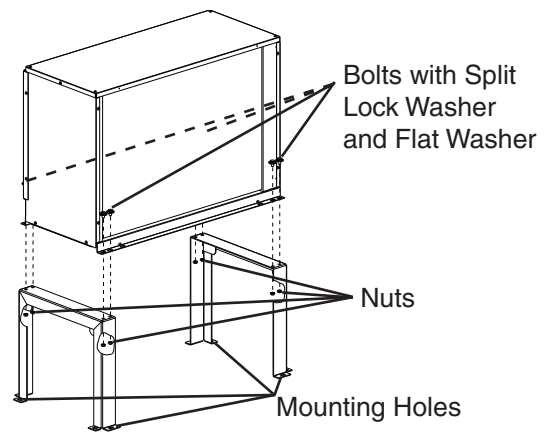

4. Line Set

CAUTION

The icemaker, line set, and remote condenser unit must contain the same type of refrigerant. Mixing of refrigerants will result in improper operation and possible damage to the refrigeration system.

- Precharged factory line sets, available as optional equipment from Hoshizaki America, are recommended. For details, see "II.F.4.a) Factory Line Set Installation." Field fabricated line sets are allowed. For details, see "II.F.4.b) Field Fabricated Line Set Installation."
- The maximum line length for the standard refrigerant charge is 66 feet. With additional refrigerant, the maximum line length is 100 feet. For details, see "II.F.5. Refrigerant Charge (Line Set Exceeding 66 Feet)."

a) Factory Line Set Installation

- 1) Route the factory line set (1/2" OD discharge line and 3/8" OD liquid line) from the remote condenser unit to the icemaker. Leave a service loop behind the icemaker to allow the icemaker to be pulled out for service. See Fig. 7. Factory fabricated line sets are precharged and do not need to be evacuated. If the line set is too long or too short, see "II.F.4.a)(1) Factory Line Set Modification."

CAUTION

1. Ensure that there are no traps and no kinks in the line set.
2. Do not coil extra line set.

- 2) Connect the refrigerant lines to the appropriate male fittings on the remote condenser unit first and then at the icemaker. Make a proper connection as follows:
 - a. Remove the protective covers from the male fitting and female coupling.
 - b. Apply Polyol Ester (POE) refrigerant oil or Parker Super O Lube to the entire male fitting, including O-ring, diaphragm, and threads before making the connection. See Fig. 8.

CAUTION

Do not use thread sealant on the fittings. Use POE refrigerant oil or Parker Super O Lube only.

- c. Make sure the male fitting and female coupling are properly aligned, then start the connection by hand to ensure that it is not cross threaded.
 - d. Tighten the connection with a wrench until it is tight. At this point, the nut has covered most of the threads on the male fitting.
 - e. Mark a reference line on the female coupling and the remote condenser unit or icemaker panel. Using a backup wrench on the back of the female coupling, tighten the six-sided nut of the female coupling an additional 1/6 turn. See Fig. 9.
- 3) If you lengthened the line set as outlined in "II.F.4.a)(1) Factory Line Set Modification" and it exceeds 66 feet, see "II.F.5 Refrigerant Charge (Line Set Exceeding 66 Feet)" for proper charging of the unit.

(1) Factory Line Set Modification

- 1) Recover the line set charge through the Schrader access ports on the Parker quick connect couplings and store it in an approved container. Do not discharge the refrigerant into the atmosphere. Remove the extra line set length or add extra tubing. When adding extra tubing, insulate the additional copper tubes separately. Braze the connections.
- 2) Use an electronic leak detector or soap bubbles to check for leaks. Add a trace of refrigerant to the lines through the Schrader access ports on the Parker quick connect couplings (if using an electronic leak detector), and then raise the pressure using nitrogen gas (140 PSIG). **WARNING! DO NOT use R-404A as a mixture with pressurized air for leak testing.**
- 3) Evacuate through the Schrader access ports on the Parker quick connect couplings and charge with R-404A refrigerant vapor to a pressure of 15 to 30 PSIG. Go to step 2 in "II. F.4.a) Factory Line Set Installation."

b) Field Fabricated Line Set Installation

- 1) Route a 1/2" OD copper tube discharge line and a 3/8" OD copper tube liquid line between the remote condenser unit and the icemaker. Leave a service loop behind the icemaker to allow the icemaker to be pulled out for service. See Fig. 7.

CAUTION

- 1. Ensure that there are no traps and no kinks in the line set.
- 2. Do not coil extra line set. Fabricate the line set to the proper length.

- 2) Insulate the two copper tubes separately.
- 3) Install Parker quick connect couplings on each end. OS-QUICK , a universal quick connect coupling kit available as optional equipment from Hoshizaki America, is recommended. **CAUTION! Before brazing, remove the Schrader valve core from the access port. When brazing, protect the coupling by using a wet cloth to prevent the coupling from overheating.**
- 4) Allow the coupling to cool, then replace the Schrader valve core.
- 5) Use an electronic leak detector or soap bubbles to check for leaks. Add a trace of refrigerant to the lines through the Schrader access ports on the Parker quick connect couplings (if using an electronic leak detector), and then raise the pressure using nitrogen gas (140 PSIG). **WARNING! DO NOT use R-404A as a mixture with pressurized air for leak testing.**

- 6) Evacuate through the Schrader access ports on the Parker quick connect couplings and charge with R-404A refrigerant vapor to a pressure of 15 to 30 PSIG.
- 7) Connect the refrigerant lines to the appropriate male fittings on the remote condenser unit first and then at the icemaker. Make a proper connection as follows:
 - a. Remove the protective covers from the male fitting and female coupling.
 - b. Apply Polyol Ester (POE) refrigerant oil or Parker Super O Lube to the entire male fitting, including O-ring, diaphragm, and threads, before making the connection. See Fig. 8.

CAUTION

Do not use thread sealant on the fittings. Use POE refrigerant oil or Parker Super O Lube only.

- c. Make sure the male fitting and female coupling are properly aligned, then start the connection by hand to ensure that it is not cross threaded.
 - d. Tighten the connection with a wrench until it is tight. At this point, the nut has covered most of the threads on the male fitting.
 - e. Mark a reference line on the female coupling and the remote condenser unit or icemaker panel. Using a backup wrench on the back of the female coupling, tighten the six-sided nut of the female coupling an additional 1/6 turn. See Fig. 9.
- 8) If the line set exceeds 66 feet, see "II.F.5 Refrigerant Charge (Line Set Exceeding 66 Feet)" for proper charging of the unit.

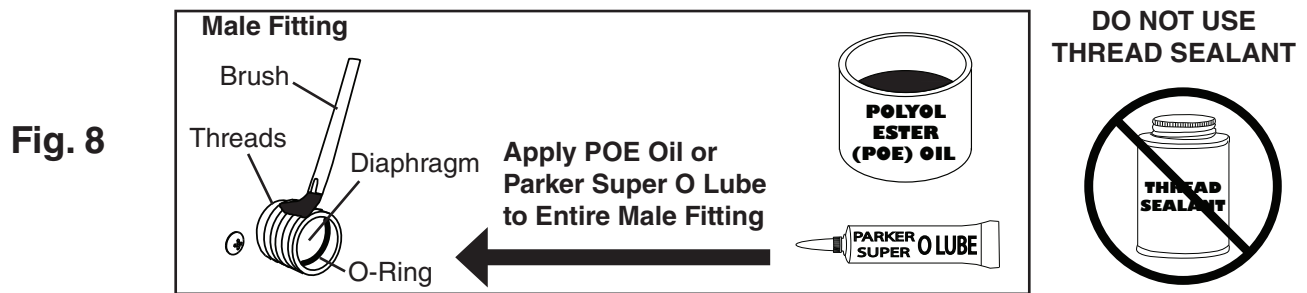
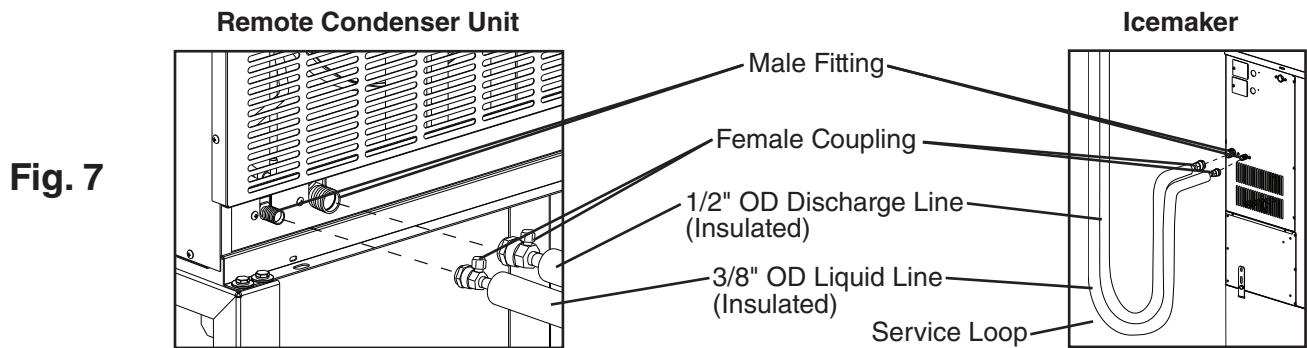

5. Refrigerant Charge (Line Set Exceeding 66 Feet)

CAUTION

The icemaker, line set, and remote condenser unit must contain the same type of refrigerant. Mixing of refrigerants will result in improper operation and possible damage to the refrigeration system.

The maximum line length for the standard refrigerant charge is 66 feet. Should an installation require a longer line length, additional refrigerant must be added. Add 0.4 oz. of R-404A for each foot over 66 feet to a maximum of 100 feet. Hoshizaki Technical Support is available at 1-800-233-1940 for recommendations.

After weighing in the additional charge, mark the unit's nameplate to show the new correct total refrigerant charge.

6. Electrical Connection

WARNING

1. Electrical connection must meet national, state, and local electrical code requirements. Failure to meet these code requirements could result in death, electric shock, serious injury, fire, or severe damage to equipment.
2. **THE REMOTE CONDENSER UNIT MUST BE GROUNDED.** Install a proper ground wire from the icemaker to the remote condenser unit. Use wire of an appropriate gage and outdoor rating. Failure to properly ground the unit could result in death or serious injury.
3. The remote condenser unit leads must be connected to the fan motor junction box leads on the icemaker. Use wire of an appropriate gage and outdoor rating.
4. Do not connect the leads to an external power source. Do not connect the icemaker's fan motor junction box leads together. Do not allow the leads to contact the junction box walls.
5. To reduce the risk of electric shock, make all remote condenser unit connections before connecting the icemaker power supply.
6. On remote air-cooled models, the icemaker should have power for a minimum of 4 hours prior to startup to prevent compressor damage.

- Usually an electrical permit and services of a licensed electrician are required.
- The opening for the power supply connection is 7/8" DIA to fit a 1/2" trade size conduit.
 - 1) Remove the louver panel. See Fig. 10.
 - 2) Remove the junction box cover on the remote condenser unit. Remove the fan motor junction box cover on the icemaker.
 - 3) Install a ground wire from the icemaker to the remote condenser unit. Use wire of an appropriate gage and outdoor rating.

- 4) Connect the fan motor leads in the junction box of the remote condenser unit to the fan motor leads in the fan motor junction box of the icemaker. Use wire of an appropriate gage and outdoor rating.
- 5) Replace the junction box covers and the louver panel in their correct positions.

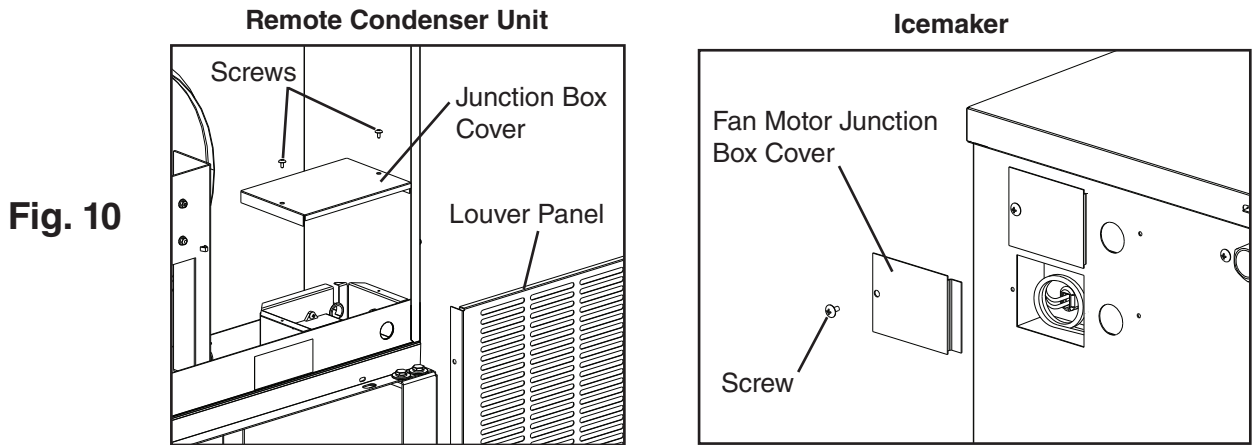

7. Stacking Remote Condenser Units

- 1) Install the lower remote condenser unit as described earlier in this section.
- 2) Place the upper remote condenser unit on top of the lower. See Fig. 11.
- 3) Secure the upper remote condenser unit to the lower remote condenser unit with the 4 screws provided.
- 4) Install refrigerant lines and make electrical connection as described earlier in this section.

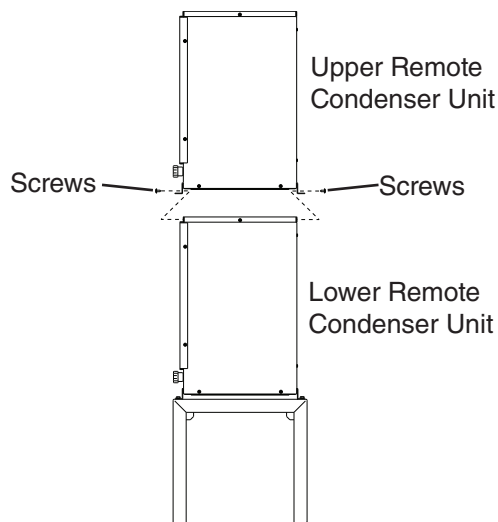

Fig. 11

G. Water Supply and Drain Connections

See Fig. 12

WARNING

1. Water supply and drain connections must be installed in accordance with applicable national, state, and local regulations.
2. Normal operating water temperature should be within 45°F to 90°F (7°C to 32°C). Operation of the icemaker, for extended periods, outside of this normal temperature range may affect icemaker performance.
3. To prevent damage to equipment, do not operate the icemaker when the water supply is off, or if the pressure is below 10 PSIG. Do not run the icemaker until the proper water pressure is reached.

- A plumbing permit and services of a licensed plumber may be required in some areas.
- External filters, strainers, or softeners may be required depending on water quality. Contact your local Hoshizaki distributor for recommendations.
- Water supply pressure should be a minimum of 10 PSIG and a maximum of 113 PSIG. If the pressure exceeds 113 PSIG, the use of a pressure reducing valve is required.
- The icemaker and condensation drain line(s) and storage bin drain line must be run separately.
- Drain lines must have 1/4" fall per foot (2 cm per 1 m) on horizontal runs to get a good flow. A vented tee connection is also required for proper flow.
- Drain lines should not be piped directly to the sewer system. An air gap of a minimum of 2 vertical inches (5 cm) should be between the end of the drain pipes from the icemaker, condensation drain, and storage bin and the floor drain.

1. Icemaker

- Icemaker water supply inlet is 1/2" female pipe thread (FPT). A minimum of 3/8" OD copper tubing is recommended for the icemaker water supply line.
- An icemaker water supply line shut-off valve and drain valve should be installed.
- Icemaker drain outlet is 3/4" FPT. A minimum of 3/4" OD hard pipe is recommended for the icemaker drain line. Condensation drain outlet is 3/8" OD tube. The condensation drain line can be connected to the icemaker drain line or can be run separately.

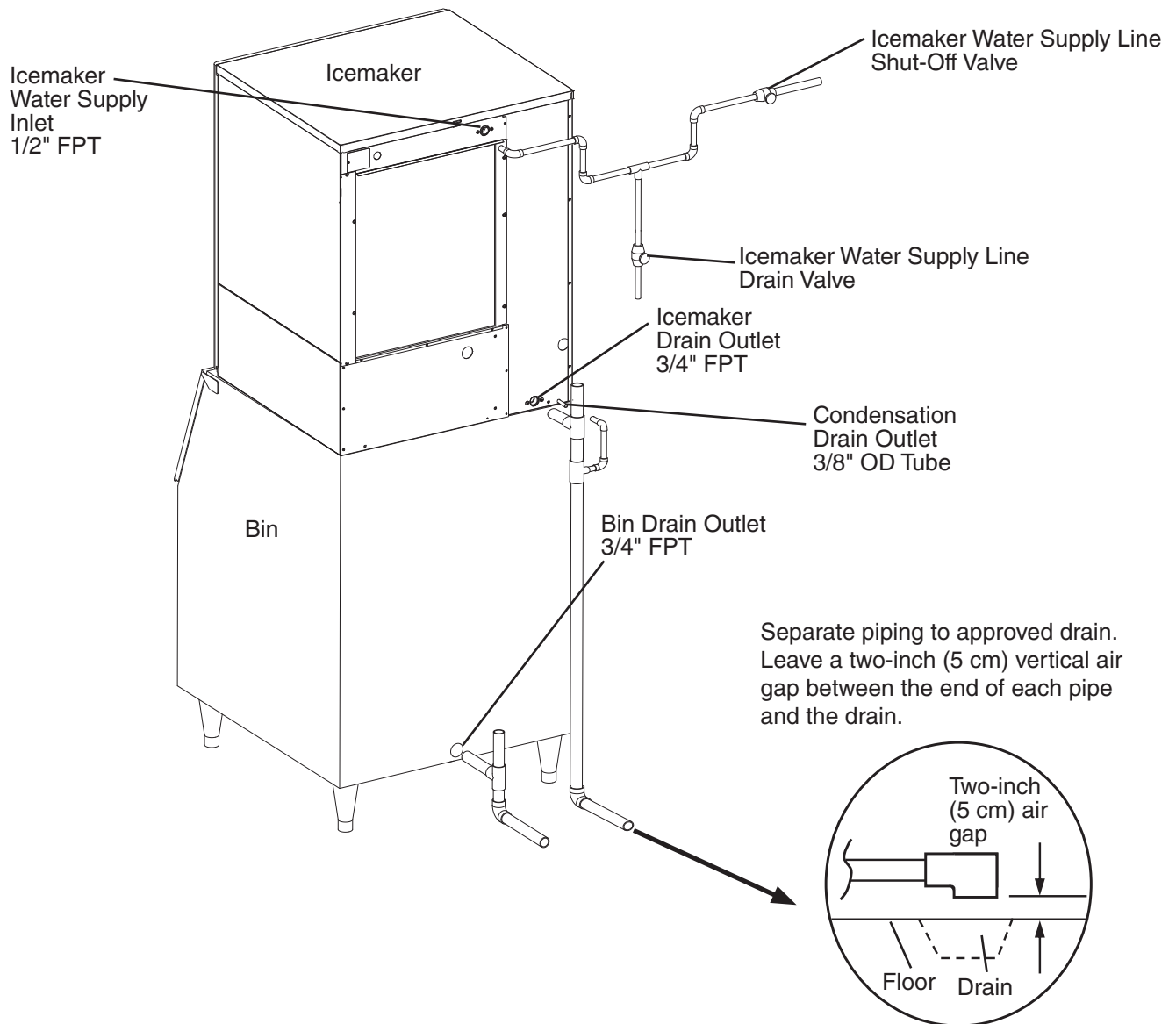

Fig. 12

KM-901MAH50 and KM-901MRH50

H. Final Checklist

WARNING

CHOKING HAZARD: Ensure all components, fasteners, and thumbscrews are securely in place after installation. Make sure that none have fallen into the storage bin.

- 1) Is the icemaker level?
- 2) Is the icemaker in a site where the ambient temperature is within 45°F to 100°F (7°C to 38°C) and the water temperature within 45°F to 90°F (7°C to 32°C) all year around?
- 3) Is there at least 6" (15 cm) clearance at sides, rear, and top of the icemaker for proper air circulation and ease of maintenance and service?
- 4) Have the shipping carton, tape, and packing material been removed from the icemaker? Is the cube guide in the correct position?
- 5) Are all components, fasteners, and thumbscrews securely in place?
- 6) Have all electrical and water connections been made? Do electrical and water connections meet all national, state, and local code and regulation requirements?
- 7) Has the power supply voltage been checked or tested against the nameplate rating? Has a proper ground been installed to the icemaker? On remote air-cooled model, has a proper ground also been installed to the remote condenser unit?
- 8) Are the water supply line shut-off valve and drain valve installed? Has the water supply pressure been checked to ensure a minimum of 10 PSIG and a maximum of 113 PSIG?
Note: The icemaker may stop running when the water supply is off, or if the pressure is below 10 PSIG. When the proper water pressure is reached, the icemaker automatically starts running again.
- 9) Are the compressor hold-down bolts snug? Have the refrigerant lines been checked to make sure they do not rub or touch other lines or surfaces? Has the fan blade (if applicable) been checked to make sure it turns freely?
- 10) On remote air-cooled model, is the refrigerant line set tightened and free of kinks?
- 11) On remote air-cooled model, has the icemaker power supply been on for a minimum of 4 hours?
- 12) Has the end user been given the instruction manual, and instructed on how to operate the icemaker and the importance of the recommended periodic maintenance?
- 13) Has the end user been given the name and telephone number of an authorized service agent?
- 14) Has the warranty card been filled out and forwarded to the factory for warranty registration?

I. Startup

⚠ WARNING

1. All parts are factory-adjusted. Improper adjustments may adversely affect safety, performance, component life, and warranty coverage.
2. If the icemaker is turned off, wait for at least 3 minutes before restarting the icemaker to prevent damage to the compressor.
3. To prevent damage to the water pump seal, do not operate the icemaker with the control switch in the "WASH" position when the water tank is empty.
4. At startup, confirm that all internal and external connections are free of leaks.
5. On remote air-cooled model, the icemaker should have power for a minimum of 4 hours prior to startup to prevent compressor damage.

- 1) Open the water supply line shut-off valve.
- 2) Remove the front panel.
- 3) Move the control switch on the control box to the "ICE" position.
- 4) Replace the front panel in its correct position.
- 5) Turn on the power supply, and allow the icemaker to operate for a total of 10 minutes.
- 6) Turn off the power supply, then remove the front panel.
- 7) Remove the base cover, then disconnect one end of the pump tubing to drain the water tank. See Fig. 13.
- 8) After the water tank has drained, reconnect the pump tubing.
- 9) Clean the storage bin liner using a neutral cleaner. Rinse thoroughly after cleaning.
- 10) Replace the base cover and the front panel in their correct positions.
- 11) Turn on the power supply to start the automatic icemaking process.
- 12) To confirm bin control operation, press and hold the bin control's actuator paddle during the first 5 minutes of the freeze cycle. The icemaker should shut down in approximately 15 seconds.

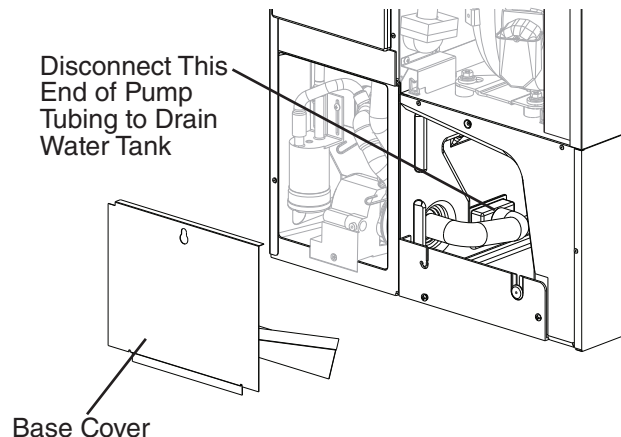

Fig. 13

III. Cleaning and Maintenance

⚠ WARNING

CHOKING HAZARD: Ensure all components, fasteners, and thumbscrews are securely in place after any cleaning or maintenance is done to the unit. Make sure that none have fallen into the storage bin.

A. Cleaning and Sanitizing Instructions

Hoshizaki recommends cleaning and sanitizing this unit at least once a year. More frequent cleaning and sanitizing, however, may be required in some existing water conditions.

⚠ WARNING

1. To prevent injury to individuals and damage to the icemaker, do not use ammonia type cleaners.
2. Carefully follow any instructions provided with the bottles of cleaning and sanitizing solution.
3. Always wear liquid-proof gloves and goggles to prevent the cleaning and sanitizing solutions from coming into contact with skin or eyes.
4. To prevent damage to the water pump seal, do not operate the icemaker with the control switch in the "WASH" position when the water tank is empty.

1. Cleaning Procedure

- 1) Dilute 16 fl. oz. (473 ml) of Hoshizaki "Scale Away" with 3 gal. (11 l) of warm water.
- 2) Remove all ice from the evaporator and the storage bin.
Note: To remove cubes on the evaporator, turn off the power supply and turn it back on after 3 minutes. The harvest cycle starts and the cubes will be removed from the evaporator.
- 3) Turn off the power supply.
- 4) Remove the front panel, then remove the insulation panel by lifting up the panel slightly and pulling it towards you.
- 5) Remove the base cover, then disconnect one end of the pump tubing to drain the water tank. See Fig. 13. After the water tank has drained, reconnect the pump tubing.
- 6) In bad or severe water conditions, clean the float switch assembly as described below. Otherwise, continue to step 7.
 - a. Disconnect the vent tube and the flush tube from the top of the float switch, then remove the float switch assembly. Remove the rubber boot from the bottom of the assembly.
 - b. Remove the retainer rod from the bottom of the float switch housing, then remove the float. Be careful not to bend the retainer rod excessively when removing it.
 - c. Wipe down the float switch assembly's housing, shaft, float, and retainer rod with cleaning solution. Clean the inside of the rubber boot and hose with cleaning solution. Rinse the parts thoroughly with clean water.
 - d. Reassemble the float switch assembly and replace it and the rubber boot in their correct positions. Reconnect the vent tube and the flush tube.

- 7) Pour the cleaning solution into the water tank.
- 8) Move the control switch on the control box to the "WASH" position.
- 9) Replace the insulation panel and the front panel in their correct positions.
- 10) Turn on the power supply to start the washing process.
- 11) Turn off the power supply after 30 minutes.
- 12) Remove the front panel.
- 13) Disconnect one end of the pump tubing to drain the water tank. After the water tank has drained, reconnect the pump tubing.
- 14) Move the control switch to the "ICE" position.
- 15) Replace the front panel in its correct position.
- 16) Turn on the power supply to fill the water tank with water.
- 17) Turn off the power supply after 3 minutes.
- 18) Remove the front panel.
- 19) Move the control switch to the "WASH" position.
- 20) Replace the front panel in its correct position.
- 21) Turn on the power supply to rinse off the cleaning solution.
- 22) Turn off the power supply after 5 minutes.
- 23) Remove the front panel.
- 24) Disconnect one end of the pump tubing to drain the water tank. After the water tank has drained, reconnect the pump tubing.
- 25) Repeat steps 14 through 24 three more times to rinse thoroughly.
Note: If you do not sanitize the icemaker, go to step 10 in "2. Sanitizing Procedure."

2. Sanitizing Procedure - Following Cleaning Procedure

- 1) Dilute a 5.25% sodium hypochlorite solution (chlorine bleach) with warm water. (Add 1.5 fl. oz. (44 ml) of sanitizer to 3 gal. (11 l) of water.)
- 2) Remove the insulation panel.
- 3) Pour the sanitizing solution into the water tank.
- 4) Replace the insulation panel and the front panel in their correct positions.
Note: Make sure the control switch is in the "WASH" position.
- 5) Turn on the power supply to start the sanitizing process.
- 6) Turn off the power supply after 15 minutes.
- 7) Remove the front panel.
- 8) Disconnect one end of the pump tubing to drain the water tank. After the water tank has drained, reconnect the pump tubing.
- 9) Repeat steps 14 through 24 in "1. Cleaning Procedure" two times to rinse thoroughly.
- 10) Move the control switch to the "ICE" position.
- 11) Replace the front panel and the base cover in their correct positions.

- 12) Clean the storage bin liner using a neutral cleaner. Rinse thoroughly after cleaning.
- 13) Turn on the power supply to start the automatic icemaking process.

B. Maintenance

This icemaker must be maintained individually, referring to the instruction manual and labels provided with the icemaker.

⚠ WARNING

1. Only qualified service technicians should attempt to service or maintain this icemaker.
2. Disconnect power before performing service or maintenance.

1. Stainless Steel Exterior

To prevent corrosion, wipe the exterior occasionally with a clean, soft cloth. Use a damp cloth containing a neutral cleaner to wipe off oil or dirt buildup.

2. Storage Bin and Scoop

- Wash your hands before removing ice. Use the plastic scoop provided (bin accessory).
- The storage bin is for ice use only. Do not store anything else in the storage bin.
- Clean the scoop and the storage bin liner using a neutral cleaner. Rinse thoroughly after cleaning.

3. Air Filters (air-cooled model)

Plastic mesh air filters remove dirt and dust from the air, and keep the condenser from getting clogged. As the filters get clogged, the icemaker's performance will be reduced. Check the filters at least twice a month. When clogged, use warm water and a neutral cleaner to wash the filters.

4. Condenser (air-cooled and remote air-cooled models)

Check the condenser once a year, and clean the coil if required by using a brush or vacuum cleaner. More frequent cleaning may be required depending on location.

C. Preparing the Icemaker for Long Storage

⚠ CAUTION

1. When storing the icemaker for an extended time or in sub-freezing temperatures, follow the instructions below to prevent damage.
2. To prevent damage to the water pump seal, do not operate the icemaker with the control switch in the "WASH" position when the water tank is empty.

When the icemaker is not used for two or three days under normal conditions, it is sufficient to move the control switch to the "OFF" position. When storing the icemaker for an extended time or in sub-freezing temperatures, follow the instructions below.

1. Remove the water from the icemaker water supply line:

- 1) Turn off the power supply, then remove the front panel.
- 2) Move the control switch on the control box to the "OFF" position.

- 3) Close the icemaker water supply line shut-off valve, then open the icemaker water supply line drain valve.
- 4) Allow the line to drain by gravity.
- 5) Attach a compressed air or carbon dioxide supply to the icemaker water supply line drain valve.
- 6) Move the control switch to the "ICE" position.
- 7) Replace the front panel in its correct position, then turn on the power supply.
- 8) Blow the icemaker water supply line out using the compressed air or carbon dioxide supply.
- 9) Close the icemaker water supply line drain valve.

2. Drain the water tank:

- 1) Turn off the power supply, then remove the front panel.
- 2) Move the control switch to the "OFF" position.
- 3) Remove the base cover, then disconnect one end of the pump tubing to drain the water tank. See Fig. 13. After the water tank has drained, reconnect the pump tubing.
- 4) Replace the base cover and the front panel in their correct positions.
- 5) Remove all ice from the storage bin. Clean the storage bin liner using a neutral cleaner. Rinse thoroughly after cleaning.

HOSHIZAKI AMERICA, INC.

618 Hwy. 74 S., Peachtree City, GA 30269 USA | TEL (770) 487-2331 | FAX (770) 487-3360 | www.hoshizaki.com | 91A1JP10A