



HOSHIZAKI

Parts List

Modular Crescent Cuber

Models

KMD-450MAH

KMD-450MWH



hoshizakiamerica.com

Number: 71275
Issued: 7-2-2009
Revised: 11-28-2017

CONTENTS

Auxiliary Codes.....	3
Note About Ordering Parts	3
A. Main Assembly & Refrigeration Circuit	4
KMD-450MAH	4
KMD-450MWH	6
B. Water Circuit	8
C. Control Box Assembly	10
D. Accessories & Labels	12

Auxiliary Codes

KMD-450MAH

U-0 July 2009
V-0 January 2010
V-1 July 2010
A-0 January 2011
A-1 November 2011
B-0 January 2012
C-0 January 2013
D-0 January 2014

KMD-450MWH

U-0 July 2009
V-0 June 2010
V-1 July 2010
A-0 February 2011
A-1 November 2011
B-0 February 2012
C-0 January 2013
D-0 January 2014

Auxiliary Code Breakdown

The auxiliary code is the first two characters in the serial number. The first character indicates the year. Years progress or regress in alphabetical order. The series runs from "A" through "V" and the letters "I" and "O" are skipped. The second character indicates significant part changes within a year. Base is "0" and this number advances for each change.

Note About Ordering Parts

Most assemblies cannot be ordered as complete units; parts in the assemblies generally must be ordered separately.

A. Main Assembly & Refrigeration Circuit
KMD-450MAH
U-0 to D-0

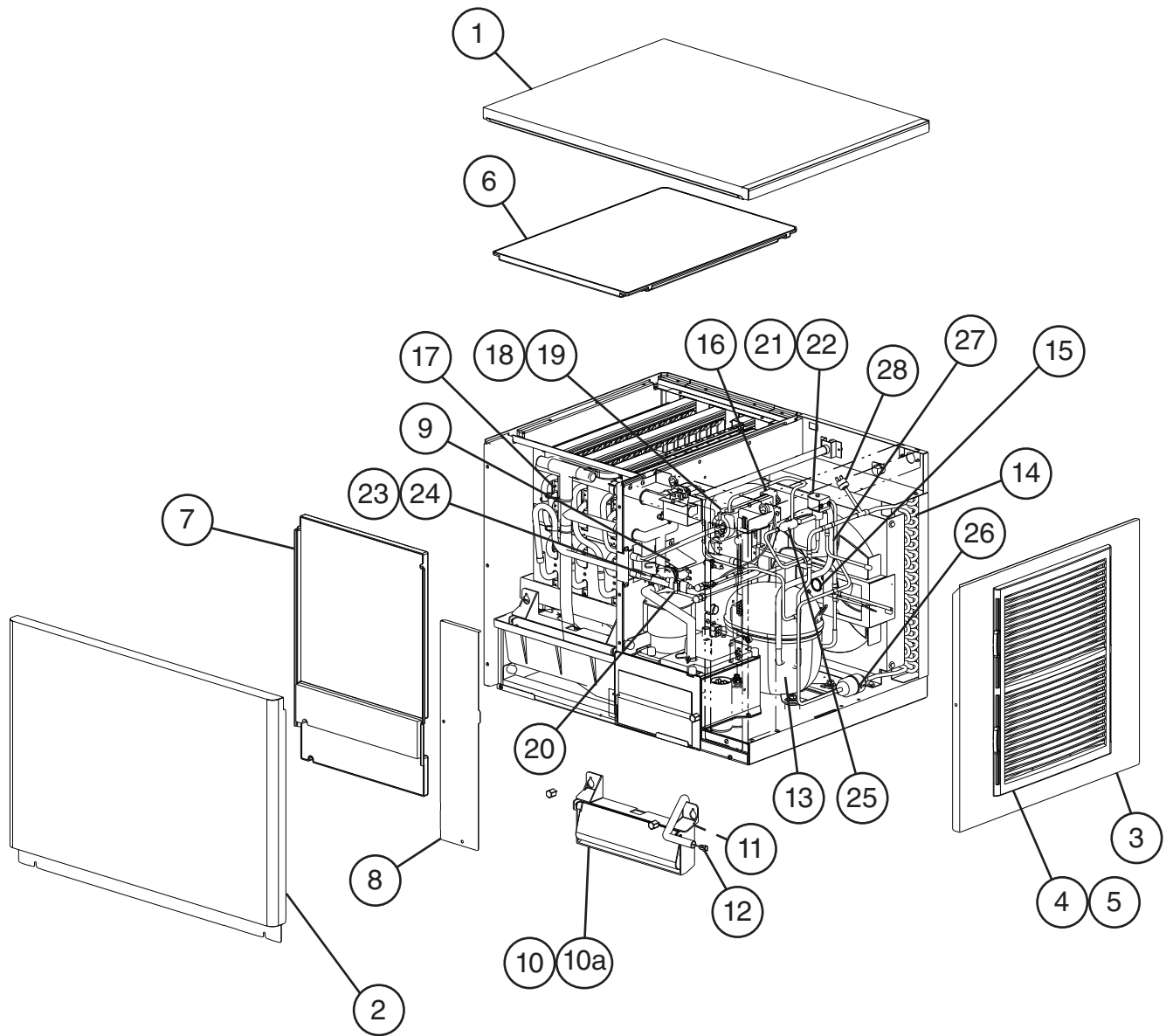

Title: A. Main Assembly & Refrigeration Circuit Model: KMD-450MAH												
Index No.	Description	Material or Model Number	Part Number	U-0 to D-0	Required Number							
Main Assembly												
1	Top Panel		3A4373G01	1								
2	Front Panel		3A5196G01	1								
3	Right Side Panel		2A4137G01	1								
4	Louver		1A1329-01	1								
5	Air Filter		2A4128G01	2								
6	Top Insulation		3A4394G01	1								
7	Front Insulation		3A5570G01	1								
8	Control Box Cover		3A4388-01	1								
9	Water Valve Cover		4A4336-01	1								
10	Mechanical Bin Control (includes items 11 and 12)		3A4861G01	1								
10a	Thumbscrew		415949G12	2								
11	Magnet		458331-01	1								
12	Reed Switch		453861-02	1								
Refrigeration Circuit												
13	Compressor		4A4479-01	1								
14	Condenser		1A1363-01	1								
15	Fan Motor (includes blade)		P02596-01	1								
16	Fan Motor Capacitor	6MFD, 220VAC	4A2128-08	1								
17	Evaporator		2A4144G01	1								
18	Thermostatic Expansion Valve		4A1414-01	1								
19	Thermostatic Expansion Valve Cover		3A0944-01	1								
20	Thermostatic Expansion Valve Holder		3A0107-01	1								
21	Hot Gas Valve Body		4A3978-01	1								
22	Valve Coil		4A3277-01	1								
23	Thermistor		P00027-01	1								
24	Thermistor Holder		427430-01	1								
25	Strainer		441569-02	1								
26	Drier		4A1113-01	1								
27	Heat Exchanger		2A5259G01	1								
28	High-Pressure Switch		463180-04	1								

A. Main Assembly & Refrigeration Circuit
KMD-450MWH
U-0 to D-0

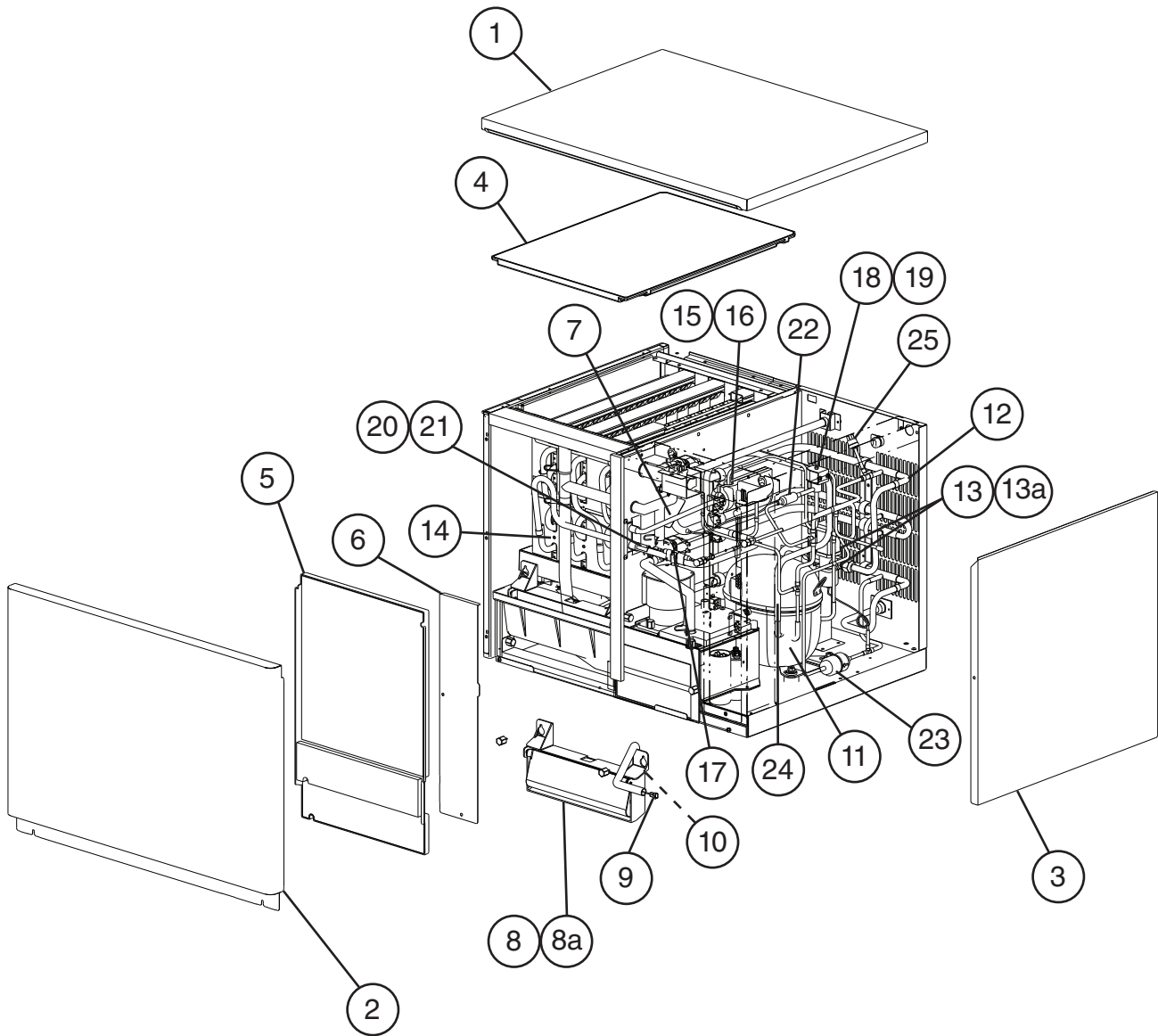

Title: A. Main Assembly & Refrigeration Circuit Model: KMD-450MWH											
Index No.	Description	Material or Model Number	Part Number	U-0 to D-0	Required Number						
Main Assembly											
1	Top Panel		3A4373G01	1							
2	Front Panel		3A5196G01	1							
3	Right Side Panel		2A4173G01	1							
4	Top Insulation		3A4394G01	1							
5	Front Insulation		3A5570G01	1							
6	Control Box Cover		3A4388-01	1							
7	Water Valve Cover		4A4338-01	1							
8	Mechanical Bin Control (includes items 9 and 10)		3A4861G01	1							
8a	Thumbscrew		415949G12	2							
9	Magnet		458331-01	1							
10	Reed Switch		453861-02	1							
Refrigeration Circuit											
11	Compressor		4A4479-01	1							
12	Condenser	HS-0201	2A4172G01	1							
13	Water Regulator		4A0911-06	1							
13a	Male Connector		4A1087-01	2							
14	Evaporator		2A4144G01	1							
15	Thermostatic Expansion Valve		4A1414-01	1							
16	Thermostatic Expansion Valve Cover		3A0944-01	1							
17	Thermostatic Expansion Valve Holder		3A0107-01	1							
18	Hot Gas Valve Body		4A3978-01	1							
19	Valve Coil		4A3277-01	1							
20	Thermistor		P00027-01	1							
21	Thermistor Holder		427430-01	1							
22	Strainer		441569-02	1							
23	Drier		4A1113-01	1							
24	Heat Exchanger		2A5259G01	1							
25	High-Pressure Switch		463180-05	1							

B. Water Circuit
KMD-450M_H
U-0 to D-0

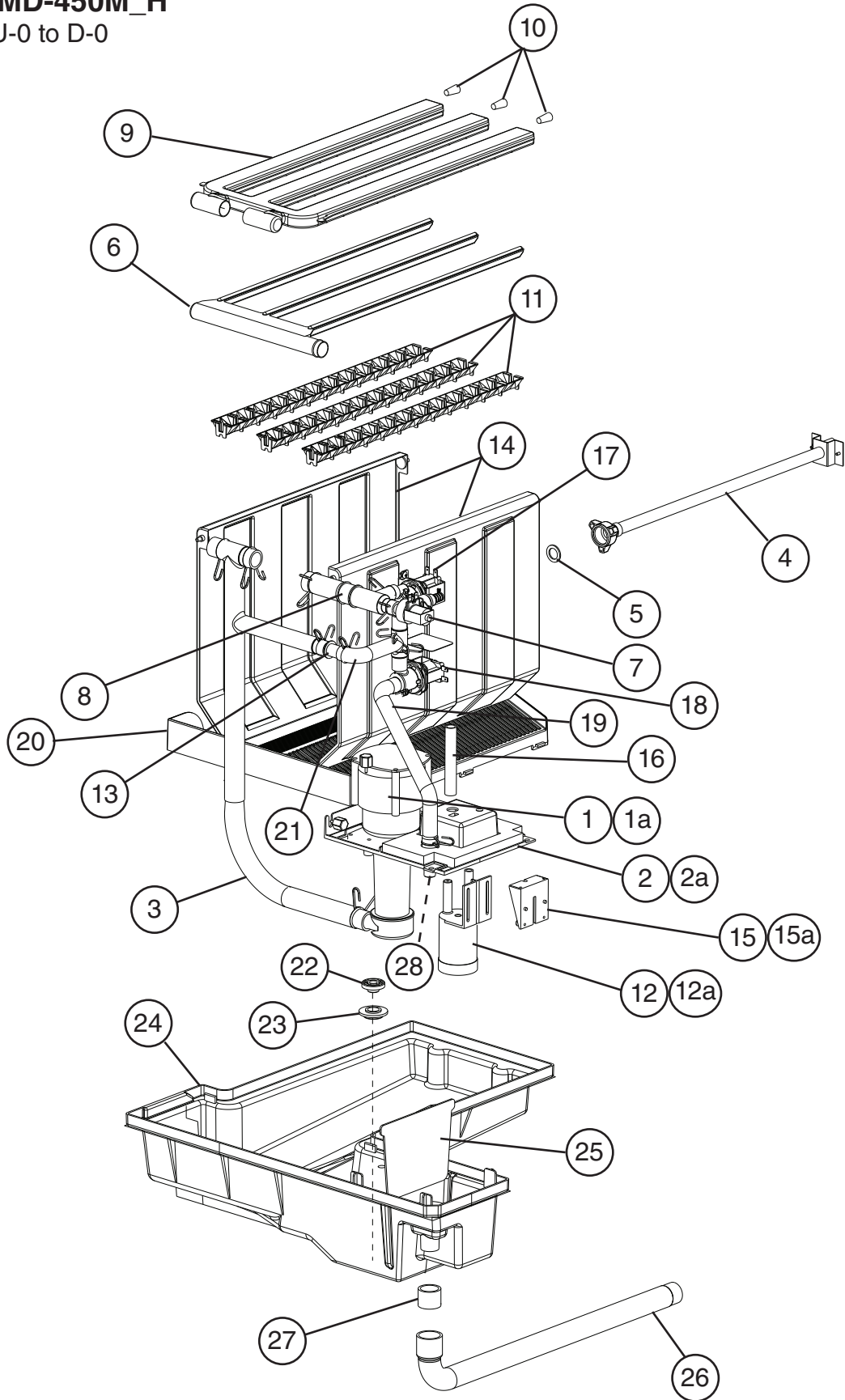

Title: B. Water Circuit Model: KMD-450M_H												
Index No.	Description	Material or Model Number	Part Number	U-0 to D-0	Required Number							
1	Pump Motor		4A4259-01	1								
1a	Thumbscrew		415949G12	1								
2	Pump Motor Bracket		4A4251G01	1								
2a	Thumbscrew		415949G12	1								
3	Pump Hose	L=225 mm	7716-2025	1								
4	Water Supply Pipe		4A4250G01	1								
5	Rubber Gasket		413854-03	1								
6	Water Supply Tube		2A4132-01	1								
7	Inlet Water Valve		3U0111-03	1								
8	Water Valve Hose (Tee)		3A4366-01	1								
9	Spray Tube		2A4133-01	1								
10	Plug		4A0176-01	3								
11	Spray Guide		2A4282-04	3								
12	Float Switch		4A3624-04	1								
12a	T2 Screw		7P32-0412	2								
13	Evaporator Pipe		3A4369-01	1								
14	Splash Curtain		3A4387G01	2								
15	Float Switch Bracket		327757-01	1								
15a	T2 Screw	4x12	7P32-0412	1								
16	Vinyl Hose	L=100 mm	7716-1216	1								
17	Wash Valve		4A3722-01	1								
18	Drain Valve		4A3722-03	1								
19	Drain Hose (A)		4A4243-01	1								
20	Cube Guide		1A1336-01	1								
21	Bypass Hose (Tee)		3A4370-01	1								
22	Drain Plug		309246-01	1								
23	O-Ring		7611-P015	1								
24	Tank		3A8316G01	1								
25	Tank Separator		4A4239-01	1								
26	Tank Drain Hose		4A4245-01	1								
27	Vinyl Hose	25 mm	4A0658L01	1								
28	Vinyl Hose		7716-1519	1								
Hose Clamps												
	Hose Clamp	18 mm	427443-05	6								
	Hose Clamp	20 mm	427443-06	1								
	Hose Clamp	25 mm	427443-03	3								

C. Control Box Assembly
KMD-450M_H
U-0 to D-0

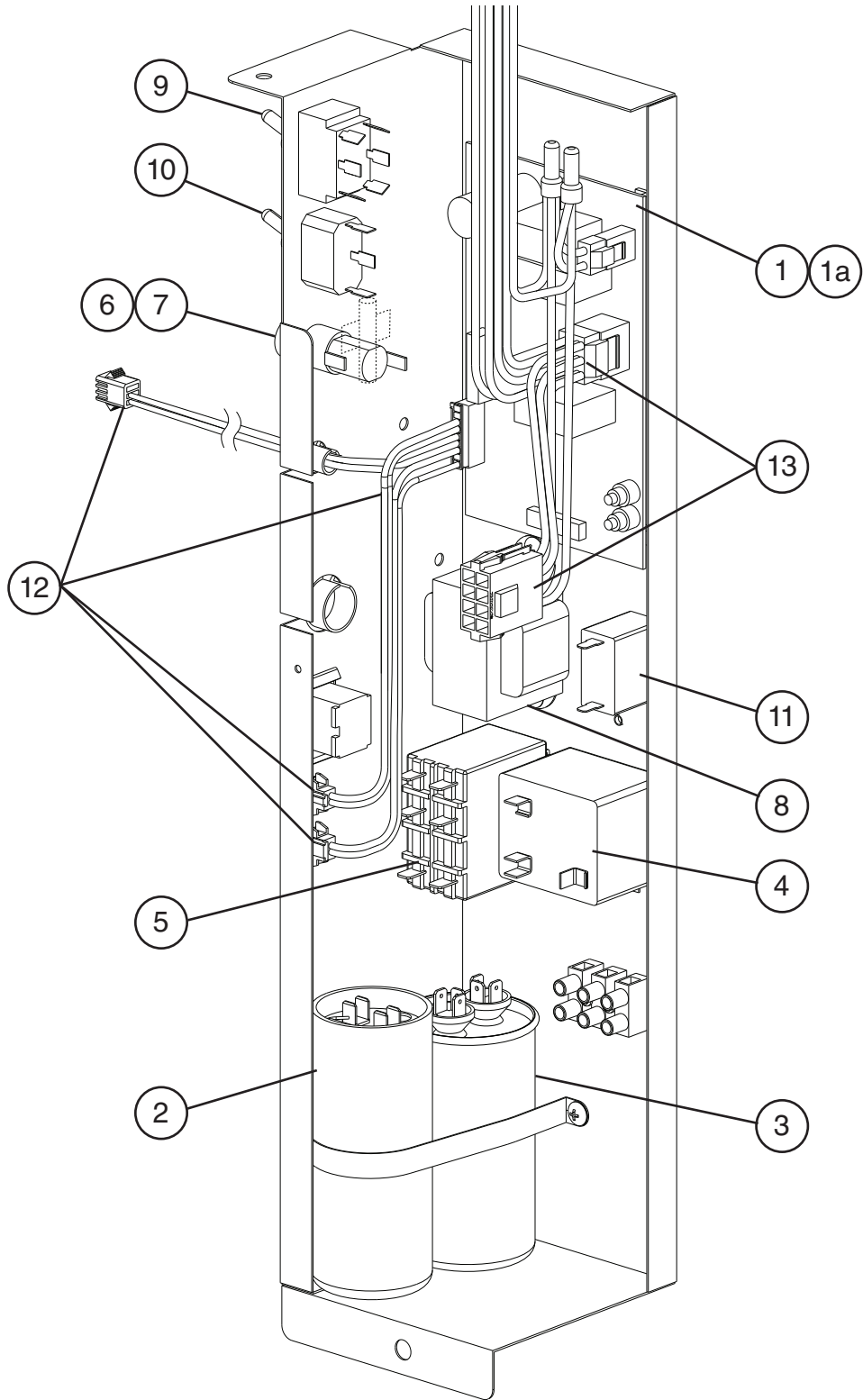

Title: C. Control Box Assembly Model: KMD-450M_H											
Index No.	Description	Material or Model Number	Part Number	Required Number							
				U-0 to V-0	V-1 to A-0	B-0 to D-0					
1	"H" Control Board		P00013-02	1	1	1					
1a	Control Board Support		4A0336-03	4	4	4					
2	Start Capacitor	243-292MFD, 165VAC	3A0076-20	1	1	1					
3	Run Capacitor	35MFD, 440VAC	3A2005-12	1	1	1					
4	Start Relay		4A1107-11	1	1	1					
5	Magnetic Contactor		428393-01	1	-						
	Compressor Relay		4A3140-01		1	1					
6	Fuse Holder		4A3449-01	1	1	-					
			4A5443-01			1					
7	Fuse	AGC-10A, 250VAC	4A0893-07	2	2	2					
8	Control Transformer		3A4395-01	1	1	1					
9	Control Switch		443119-01	1	1	1					
10	Service Switch		4A0985-01	1	1	1					
11	Pump Motor Capacitor	2.5MFD, 250VAC	4A2128-05	1	1	1					
12	Wire Harness (A)		4A4950G01	1	1	1					
13	Wire Harness (diagnostic connector)		3A4673G01	1	1	1					

D. Accessories & Labels
KMD-450M_H
 U-0 to D-0

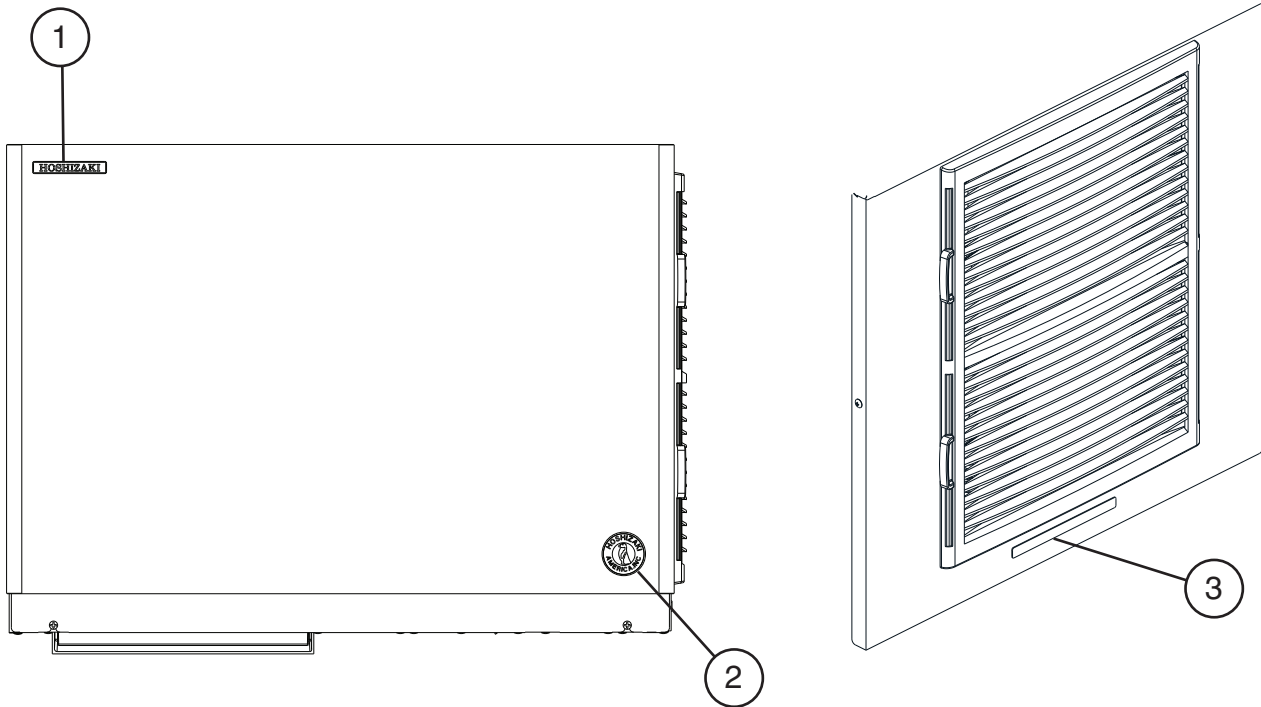

Title: D. Accessories & Labels Model: KMD-450M_H					Required Number								
Index No.	Description	Material or Model Number	Part Number	U-0 to D-0									
1	Emblem		4A0560-01	1									
2	Label-Penguin-HA-L		456246-02	1									
3	Label-Air Filter	KMD-450MAH	426177-01	1									
4	Universal Brace		4A0363-01	2									
4a	Hex Bolt Assembly	5×12	7B0130512	2									