



# HOSHIZAKI

## Parts List

Modular Crescent Cuber

Models

KML-45 IMAH

KML-45 IMVH



[hoshizakiamerica.com](http://hoshizakiamerica.com)

Number: 71262  
Issued: 10-12-2006  
Revised: 12-21-2016

## CONTENTS

Auxiliary Codes.....	3
Note About Ordering Parts .....	3
A. Ice Cuber Assembly & Refrigeration Circuit .....	4
KML-451MAH.....	4
KML-451MWH.....	6
B. Water Circuit.....	8
C. Control Box Assembly .....	10
D. Accessories & Labels .....	12

## Auxiliary Codes

<b>KML-451MAH</b>	R-0	June 2006	<b>KML-451MWH</b>	R-0	June 2006
	S-1	January 2007		S-1	April 2007
	S-2	December 2007		S-2	December 2007
	T-0	January 2008		T-0	January 2008
	T-1	November 2008		U-0	January 2009
	T-2	December 2008		U-1	January 2009
	U-0	January 2009		V-0	January 2010
	U-1	August 2009		V-1	July 2010
	V-0	January 2010		V-2	December 2010
	V-1	July 2010		A-0	January 2011
	A-0	January 2011		A-1	September 2011
	A-1	September 2011		B-0	January 2012
	B-0	January 2012		B-1	November 2012
	B-1	November 2012		C-0	January 2013
	C-0	January 2013		D-0	January 2014
	D-0	January 2014		E-0	February 2015
	E-0	February 2015		F-0	January 2016
	F-0	January 2016			

## Auxiliary Code Breakdown

The auxiliary code is the first two characters in the serial number. The first character indicates the year. Years progress or regress in alphabetical order. The series runs from "A" through "V" and the letters "I" and "O" are skipped. The second character indicates significant part changes within a year. Base is "0" and this number advances for each change. In cases where there is a letter in parentheses, this designates the month. This is the last character in the serial number. The series runs from "(A)" through "(M)" and the letter "(I)" is skipped. This designation is only included when identifying a parts change within an auxiliary code.

## Note About Ordering Parts

Most assemblies cannot be ordered as complete units; parts in the assemblies generally must be ordered separately.

**A. Ice Cuber Assembly & Refrigeration Circuit**  
**KML-451MAH**  
 R-0 to F-0

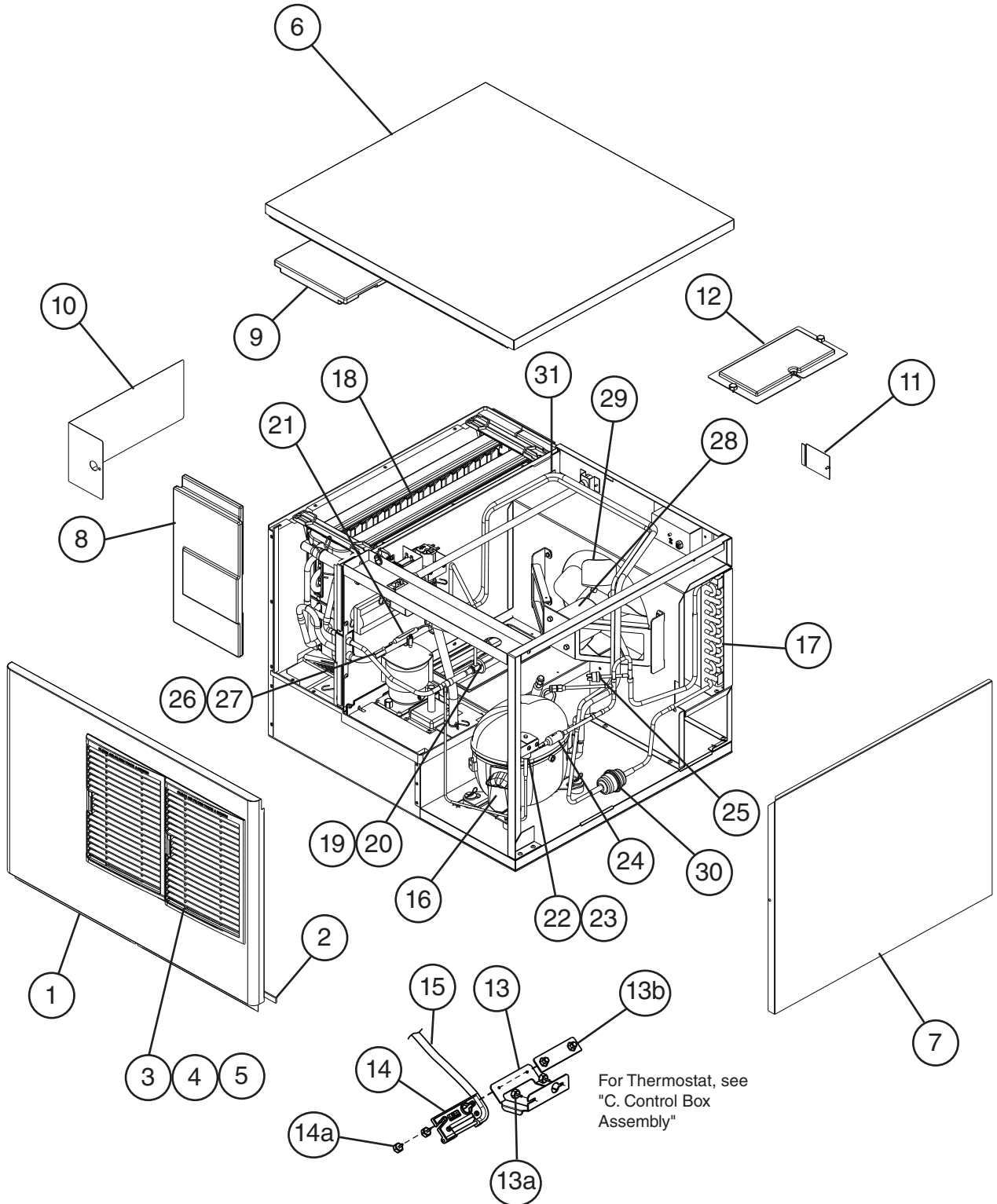

Title: A. Ice Cuber Assembly Model: KML-451MAH											
Index No.	Description	Material Or Model Number	Part Number	Required Number							
				R-0 to T-0 U-0	T-1 to U-1 F-0						
<b>Ice Cuber Assembly</b>											
1	Front Panel		2A2107-01	1	1						
2	Gasket		4A0808L02	1	1						
3	Louver		1A0548-01	2	2						
4	Push Retainer		4A2414-01	6	6						
5	Air Filter		2A2063G01	2	2						
6	Top Panel		3A1862A01	1	1						
7	Right Side Panel		2A2111G01	1	1						
8	Front Insulation		2A4540A01	1	1						
9	Top Insulation		215730G01	1	1						
10	Control Box Cover		3A2371-01	1	1						
11	Junction Box Cover		433410-01	1	1						
12	Bin Control Cover		3A0586-01	1	1						
13	Bin Control Thermostat Extension Bracket		4A4358-01	1	1						
13a	Thumbscrew		415949G10	2	2						
13b	NSF Plate		4A4401G01	1	1						
14	Bin Control Bulb Holder		3A3903-01		1						
14a	Thumbscrew		415949G11		2						
15	Silicone Hose	L=310 mm	7730I3812	1	1						
<b>Refrigeration Circuit</b>											
16	Compressor		4A2300-01	1	-						
			4A4479-01		1						
17	Condenser		2A0640-01	1	1						
18	Evaporator Assembly		2A0717G01	1	1						
19	Thermostatic Expansion Valve		4A4008-01	1	-						
			4A1684-01		1						
20	Thermostatic Expansion Valve Cover		3A0944-01	1	1						
21	Thermostatic Expansion Valve Bulb Holder		3A0107-01	1	1						
22	Hot Gas Valve Body		4A3978-01	1	1						
23	Valve Coil		4A3277-01	1	1						
24	Strainer		4A0397-01	1	-						
			441569-02		1						
25	High-Pressure Switch		433441-07	1	-						
			463180-04		1						
26	Thermistor		429006-03	1	1						
27	Thermistor Holder		427430-01	1	1						
28	Fan Motor		4A3158-01	1	1						
29	Fan Blade		4A4014-01	1	1						
30	Drier		4A2666-01	1	1						
31	Heat Exchanger		2A3685G01	1	-						
			2A4894G01		1						

# A. Ice Cuber Assembly & Refrigeration Circuit

## KML-451MWH

V-0 to F-0

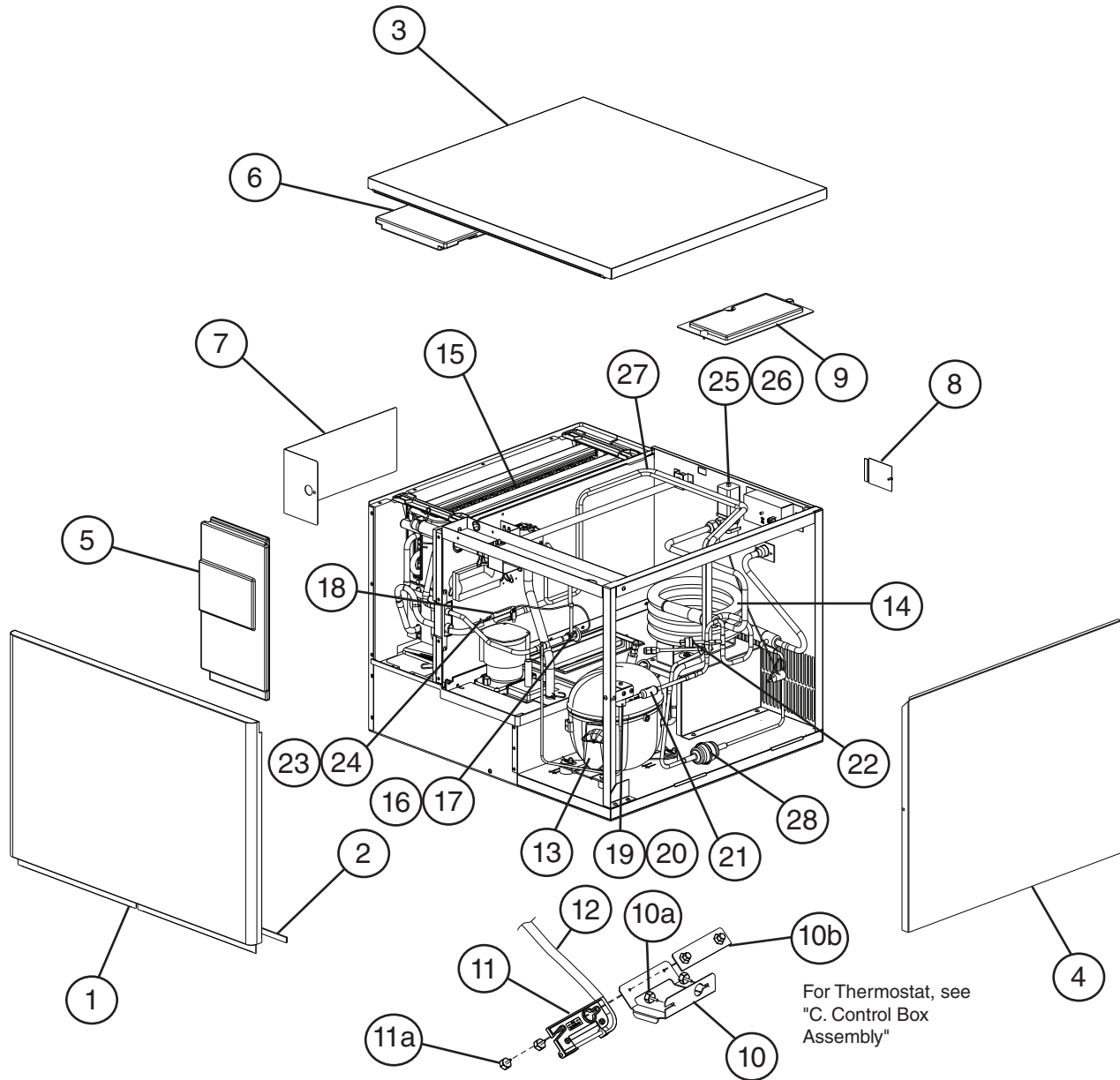

Title: A. Ice Cuber Assembly Model: KML-451MWH												
Index No.	Description	Material or Model Number	Part Number	Required Number								
				R-0 to U-0	U-1 to B-1	C-0 F-0						
<b>Ice Cuber Assembly</b>												
1	Front Panel		2A2107-02	1	1	1						
2	Gasket		4A0808L02	1	1	1						
3	Top Panel		3A1862A01	1	1	1						
4	Right Side Panel		2A2111G01	1	1	1						
5	Front Insulation		2A0664G01	1	1	1						
6	Top Insulation		215730G01	1	1	1						
7	Control Box Cover		3A2371-01	1	1	1						
8	Junction Box Cover		433410-01	1	1	1						
9	Bin Control Cover		3A0586-01									
10	Bin Control Thermostat Extension Bracket		4A4358-01	1	1	1						
10a	Thumbscrew		415949G10	2	2	2						
10b	NSF Plate		4A4401G01	1	1	1						
11	Bin Control Bulb Holder		3A3903-01		1	1						
11a	Thumbscrew		415949G11		2	2						
12	Silicone Hose	L=310 mm	7730I3812	1	1	1						
<b>Refrigeration Circuit</b>												
13	Compressor		4A2300-01	1	-							
			4A4376-01		1	1						
14	Condenser		2A2359G01	1	1	-						
			3A7321-01			1						
14a	Hex Head Bolt w/Washer (LF)	5x12	7B0130512	2	2	2						
15	Evaporator		2A0717G01	1	1	1						
16	Thermostatic Expansion Valve		4A4008-01	1	-							
			4A1684-01		1	1						
17	Thermostatic Expansion Valve Cover		3A0944-01	1	1	1						
18	Thermostatic Expansion Valve Bulb Holder		3A0107-01	1	1	1						
19	Hot Gas Valve Body		4A3978-01	1	1	1						
20	Valve Coil		4A3277-01	1	1	1						
21	Strainer		4A0397-01	1	-							
			441569-02		1	1						
22	High-Pressure Switch		433441-05	1	-							
			463180-05		1	1						
23	Thermistor		429006-03	1	1	1						
24	Thermistor Holder		427430-01	1	1	1						
25	Water Regulator		4A0911-06	1	1	1						
26	Male Connector		4A1087-01	1	1	1						
27	Heat Exchanger		2A3685G01	1	-							
			2A4894G01		1	1						
28	Drier		4A2666-01	1	1	1						

**B. Water Circuit**  
**KML-451MAH, KML-451MWH**  
R-0 to F-0

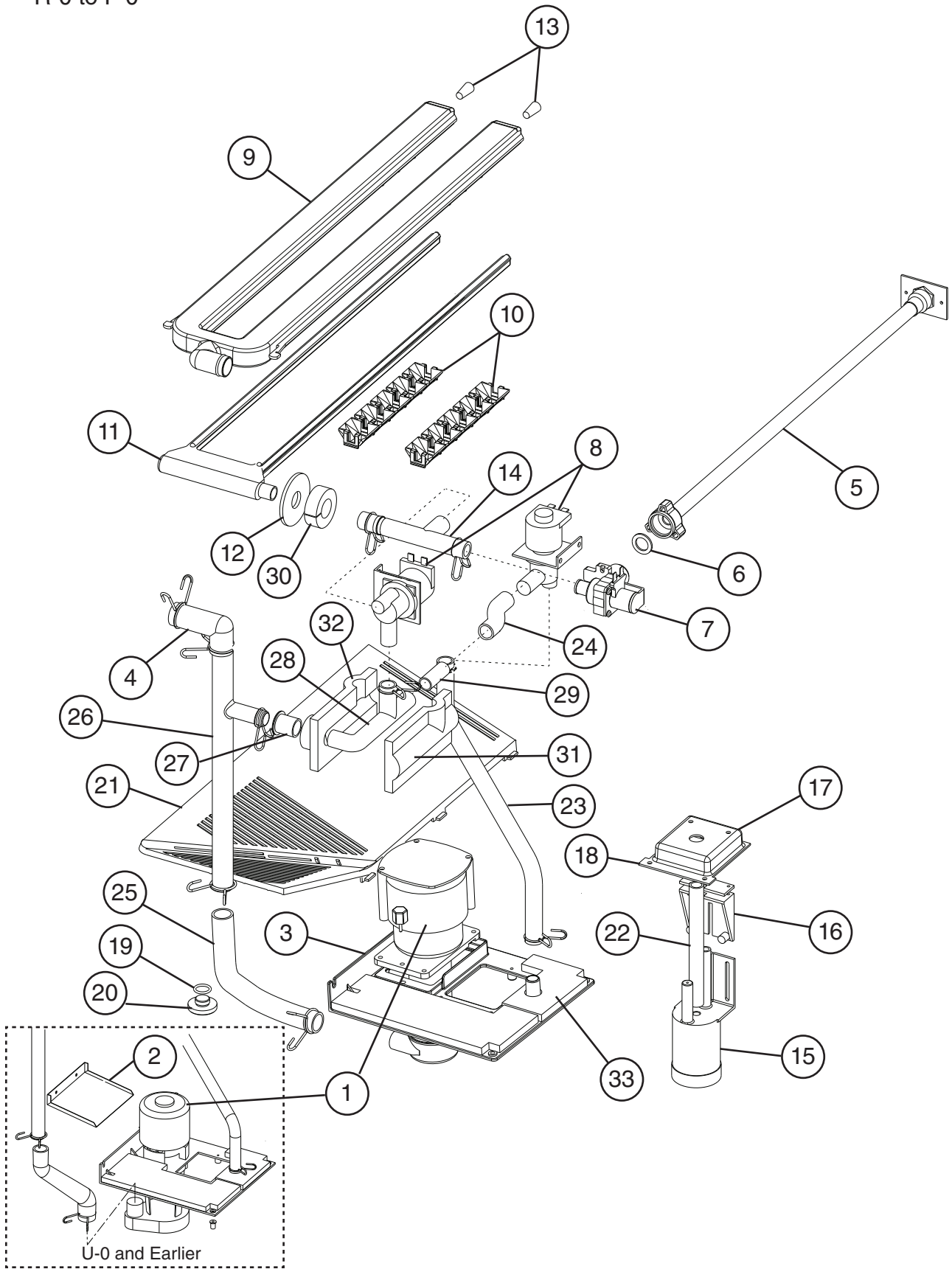



Title: B. Water Circuit Model: KML-451MAH, KML-451MWH													
Index No.	Description	Material or Model Number	Part Number	Required Number									
				R-0 S-1	S-2 T-0	T-0 to U-0	U-1 to F-0						
1	Pump Motor		HS-0232	1	1	1	-						
			4A4259-01				1						
2	Barrier		4A2997-01	1	1	1	-						
3	Pump Motor Bracket		2A4920G01				1						
4	Elbow		4A0393-01	1	1	1	1						
5	Water Supply Pipe		4A0768G04	1	1	1	1						
6	Rubber Gasket		413854-03	1	1	1	1						
7	Inlet Water Valve		3U0150-01	1	1	1	1						
8	Solenoid Valve (Drain and Cleaning Valve)		439322-01	2	-								
			4A3722-01		2	2	2						
9	Spray Tube		1A0260-02	1	1	1	1						
10	Spray Guide		208586-01	6	6	6	6						
11	Water Supply Tube		2A0079-01	1	1	1	1						
12	Flange		439267-01	1	1	1	1						
13	Plug		4A0176-01	2	2	2	2						
14	Water Supply Tee		4A1006-01	1	1	1	1						
15	Float Switch		4A3624-01	1	1	1	1						
16	Float Switch Bracket		327757-01	1	1	1	1						
17	Float Switch Cover		3A0665-01	1	1	1	1						
18	Float Switch Spacer		4A0650-01				1						
19	O-Ring		7611-P015	1	1	1	1						
20	Drain Plug		309246-01	1	1	1	1						
21	Cube Guide		2A0660-01	1	1	1	1						
22	Vinyl Hose	L=150 mm	7716-1216	1	1	1	1						
23	Vinyl Hose	L=325 mm	7716-1519	1	1	1	1						
24	Vinyl Hose	L=55 mm	7716-1519	1	1	1	1						
25	Pump Hose		325867-01	1	1	1	1						
26	Connecting Pipe		3A1335-01	1	1	1	1						
27	Rubber Ring		4A1004-01	1	1	1	1						
28	By Pass Hose		4A1005-01	1	1	1	1						
29	Joing Pipe		439329-01	1	1	1	1						
30	Insulation E		4A0392-01	1	1	1	1						
31	Insulation A1		4A1259-01	1	1	1	1						
32	Insulation A2		4A1260-01	1	1	1	1						
33	Insulation B		4A1053-01	1	1	1	1						
<b>Hose Clamps</b>													
	Hose Clamp	18 mm	427443-05	5	5	5	5						
	Hose Clamp	27 mm	427443-08	1	1	1	1						
	Hose Clamp	20 mm	427443-06	2	2	2	2						
	Hose Clamp	18 mm	4A2017-06	3	-								
			427443-05		3	3	3						
	Hose Clamp	25 mm	427443-03	3	3	3	3						

# C. Control Box Assembly

## KML-451MAH, KML-451MWH

R-0 to F-0

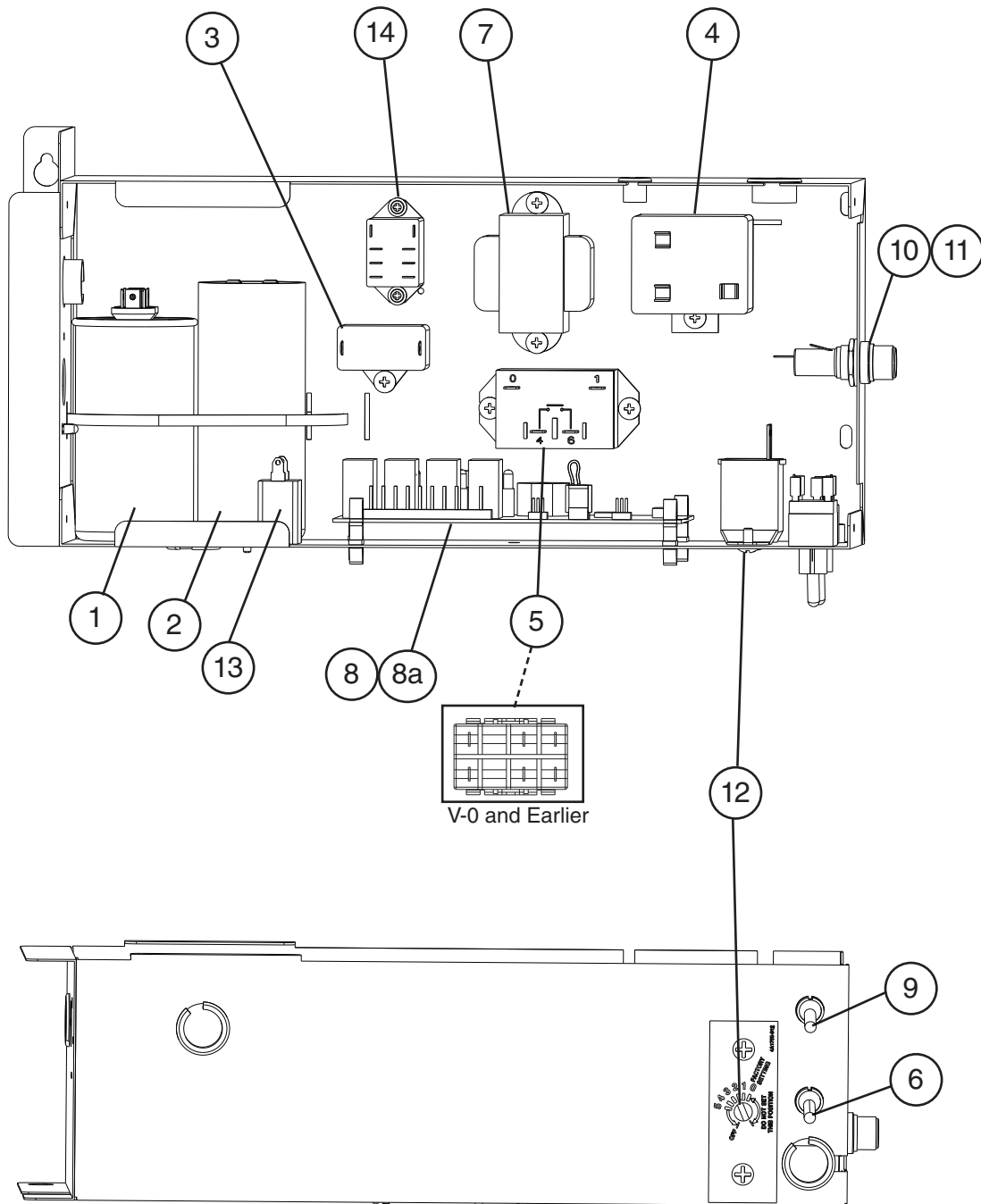

Title: C. Control Box Assembly Model: KML-451MAH, KML-451MWH										
Index No.	Description	Material or Model Number	Part Number	Required Number						
				R-0 to T-0 U-0	T-1 to U-1 V-0	V-1 to B-0	B-1 to F-0			
1	Start Capacitor	243-292MFD, 115VAC	3A0076-10	1	-					
		243-292MFD, 165VAC	3A0076-20		1	1	1			
2	Run Capacitor	15MFD, 370VAC	3A2005-08	1	-					
		35MFD, 440VAC	3A2005-12		1	1	1			
3	Fan Motor Capacitor	<b>KML-451MAH</b> 5MFD, 250 VAC	443192-02	1	1	1	1			
4	Start Relay		4A1107-11	1	1	1	1			
5	Magnetic Contactor		428393-01	1	1	-				
	Compressor Relay		4A3140-01			1	1			
6	Service Switch		4A0985-01	1	1	1	1			
7	Control Transformer		3A0172-01	1	1	1	1			
8	Control Board	"E" Control Board	2A1410-01	1	1	1	-			
		"G" Control Board	2A3792-01				1			
8a	Control Board Support		4A0336-03	4	4	4	4			
9	Control Switch		443119-01	1	1	1	1			
10	Fuse Holder		4A5443-01	1	1	1	1			
11	Fuse		4A0893-07	2	2	2	2			
12	Bin Control Thermostat		4A2879-01	1	1	1	1			
13	Pump Motor Capacitor	2.5 MFD, 250 VAC	4A2128-05			1	1			
14	Relay (Drain)		406132-07	1	1	1	1			

**D. Accessories & Labels**  
**KML-451MAH, KML-451MWH**  
 R-0 to F-0

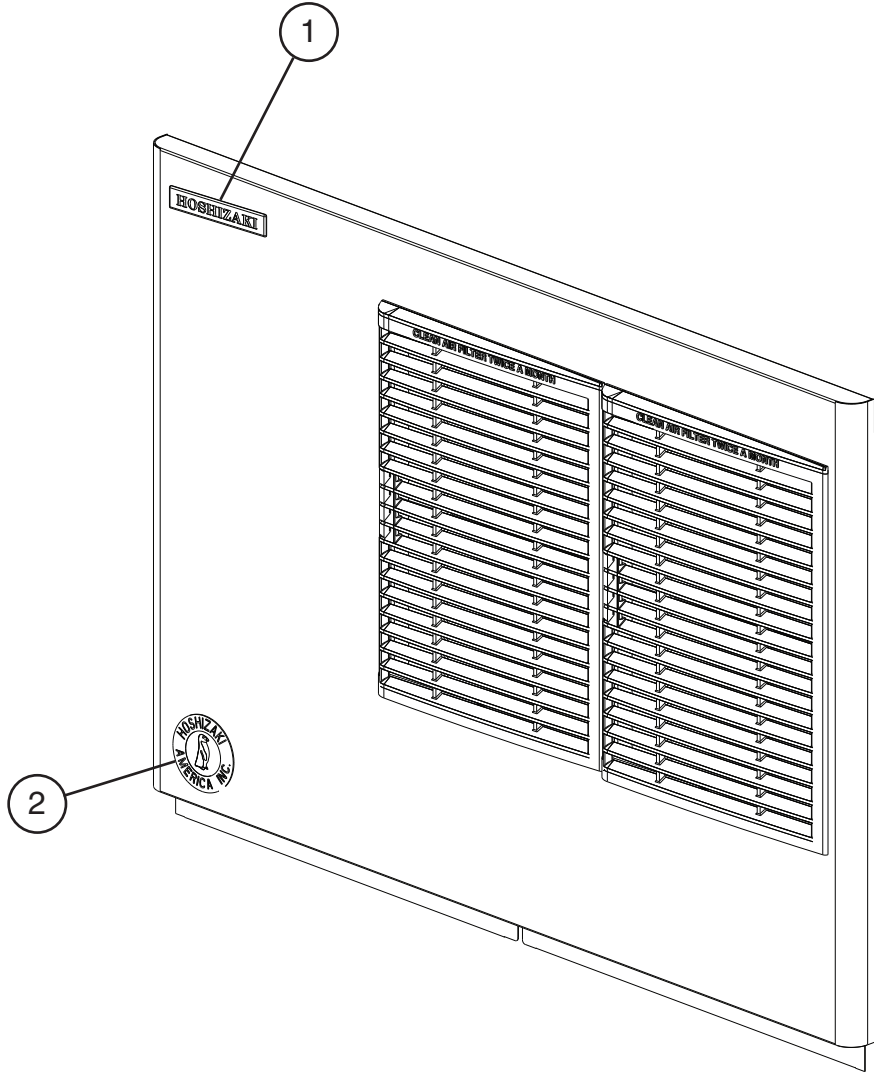

Title: D. Accessories & Labels		Model: KML-451MAH, KML-451MWH		Required Number								
Index No.	Description	Material or Model Number	Part Number	R-0 to F-0								
1	Hoshizaki Emblem Label		4A0560-01	1								
2	Penguin Label		4A0526-01	1								
3	Universal Brace		4A0363-01	2								
3a	Hex Head Bolt	5x12	7B02-0512	2								