

ISSUED: FEB. 28, 2001

REVISED: SEPT. 24, 2001



# **HOSHIZAKI MODULAR CRESCENT CUBER**

**MODELS**

**KML-600MAH**

**KML-600MWH**

**KML-600MRH**

**INSTRUCTION MANUAL**

## **IMPORTANT**

Only qualified service technicians should attempt to install, service or maintain this icemaker. No installation, service or maintenance should be undertaken until the technician has thoroughly read this Instruction Manual. Likewise, the owner/manager should not proceed to operate the icemaker until the installer has instructed them on its proper operation.

HOSHIZAKI provides this manual primarily to assist qualified service technicians in the installation, maintenance and service of the icemaker.

Should the reader have any questions or concerns which have not been satisfactorily addressed, please call or write to the HOSHIZAKI Technical Support Department for assistance.

HOSHIZAKI AMERICA, INC.  
618 Highway 74 South  
Peachtree City, GA 30269

Attn: HOSHIZAKI Technical Support Department

Phone: 1-800-233-1940 Technical Service  
(770) 487-2331  
Fax: (770) 487-3360

**NOTE:** To expedite assistance, all correspondence/communication **MUST** include the following information:

- Model Number
- Serial Number
- Complete and detailed explanation of the problem

- Please review this manual. It should be read carefully before the icemaker is installed and operated. Only qualified service technicians should install, service and maintain the icemaker. This manual should be made available to the technician prior to installation, maintenance or service.
- Keep this manual with the icemaker for future reference.

## CONTENTS

	PAGE
I. SPECIFICATIONS .....	4
1. NAMEPLATE RATING .....	4
[a] KML-600MAH (Air-cooled) .....	4
[b] KML-600MWH (Water-cooled) .....	5
[c] KML-600MRH (Remote Air-cooled) .....	6
2. DIMENSIONS/CONNECTIONS .....	7
[a] KML-600MAH .....	7
[b] KML-600MWH .....	8
[c] KML-600MRH .....	9
II. INSTALLATION AND OPERATING INSTRUCTIONS .....	10
1. CHECKS BEFORE INSTALLATION .....	10
2. HOW TO REMOVE PANELS .....	11
3. LOCATION .....	11
4. SET UP .....	12
5. ELECTRICAL CONNECTION .....	12
6. INSTALLATION OF REMOTE CONDENSER UNIT .....	13
[a] CHECKS BEFORE INSTALLATION .....	13
[b] LOCATION .....	13
[c] SET UP .....	14
[d] ELECTRICAL CONNECTION .....	15
[e] STACKING CONDENSER UNIT .....	16
7. WATER SUPPLY AND DRAIN CONNECTIONS .....	17
8. FINAL CHECK LIST .....	19
9. START UP .....	20
10. PREPARING THE ICEMAKER FOR LONG STORAGE .....	22
III. CLEANING AND MAINTENANCE INSTRUCTIONS .....	24
1. CLEANING INSTRUCTIONS .....	24
[a] CLEANING PROCEDURE .....	24
[b] SANITIZING PROCEDURE .....	26
2. MAINTENANCE .....	27

# I. SPECIFICATIONS

## 1. NAMEPLATE RATING

[a] KML-600MAH (Air-cooled)

<b>HOSHIZAKI ICE MAKER</b>			
<b>MODEL NUMBER</b>	<b>KML-600MAH</b>		
<b>SERIAL NUMBER</b>			
<b>AC SUPPLY VOLTAGE</b>	<b>208-230/60/1 (3 WIRE WITH NEUTRAL FOR 115 V)</b>		
<b>COMPRESSOR</b>	<b>208-230 V</b>	<b>9.5RLA</b>	<b>56LRA</b>
<b>PUMP</b>	<b>120V</b>	<b>0.54FLA</b>	<b>10W</b>
<b>FAN</b>	<b>120V</b>	<b>0.85FLA</b>	<b>50W</b>
<b>OTHER</b>	<b>115-120V</b>	<b>0.15A</b>	
<b>MAXIMUM FUSE SIZE</b>	<b>20 AMPS</b>		
<b>MAX. HACR BREAKER (USA ONLY)</b>	<b>20 AMPS</b>		
<b>MAX. CIRC. BREAKER (CANADA ONLY)</b>	<b>20 AMPS</b>		
<b>MINIMUM CIRCUIT AMPACITY</b>	<b>20 AMPS</b>		
<b>DESIGN PRESSURE</b>	<b>HI-467PSI LO-230PSI</b>		
<b>REFRIGERANT</b>	<b>404A 2LB. 4 OZ.</b>		
<b>MOTOR-COMPRESSOR THERMALLY PROTECTED</b>			
<b>NOT INTENDED FOR OUTDOOR USE</b>			
<b>HOSHIZAKI AMERICA, INC.</b> Peachtree City, GA			
 LISTED ICE MAKER WITHOUT STORAGE MEANS 946Z			 COMPONENT
			
			

See the Nameplate for electrical and refrigeration specifications. This Nameplate is located on the upper right hand side of the rear panel.

Since this Nameplate is located on the rear panel of the icemaker, it cannot be read when the back of the icemaker is against a wall or against another piece of kitchen equipment. Therefore, the necessary electrical and refrigeration information is also on the rating label, which can be easily seen by removing only the front panel of the icemaker.

We reserve the right to make changes in specifications and design without prior notice.

[b] KML-600MWH (Water-cooled)

<b>HOSHIZAKI ICE MAKER</b>	
<b>MODEL NUMBER</b>	<b>KML-600MWH</b>
<b>SERIAL NUMBER</b>	
<b>AC SUPPLY VOLTAGE</b>	<b>208-230/60/1 (3 WIRE WITH NEUTRAL FOR 115V)</b>
<b>COMPRESSOR</b>	<b>208-230V 8.3RLA 56LRA</b>
<b>PUMP</b>	<b>120V .54FLA 10W</b>
<b>FAN</b>	<b>---</b>
<b>OTHER</b>	<b>115-120V 0.15A</b>
<b>MAXIMUM FUSE SIZE</b>	<b>20 AMPS</b>
<b>MAX. HACR BREAKER (USA ONLY)</b>	<b>20 AMPS</b>
<b>MAX. CIRC. BREAKER (CANADA ONLY)</b>	<b>20 AMPS</b>
<b>MINIMUM CIRCUIT AMPACITY</b>	<b>20 AMPS</b>
<b>DESIGN PRESSURE</b>	<b>HI-427PSI LO-230PSI</b>
<b>REFRIGERANT</b>	<b>404A 1LB. 4.5OZ.</b>
<b>MOTOR-COMPRESSOR THERMALLY PROTECTED</b>	
<b>NOT INTENDED FOR OUTDOOR USE</b>	

**HOSHIZAKI AMERICA, INC.**  
Peachtree City, GA

UL LISTED ICE MAKER WITHOUT STORAGE MEANS 946Z

UL NSF COMPONENT

NSF INTERNATIONAL





V

See the Nameplate for electrical and refrigeration specifications. This Nameplate is located on the upper right hand side of rear panel.

Since this Nameplate is located on the rear panel of the icemaker, it cannot be read when the back of the icemaker is against a wall or against another piece of kitchen equipment. Therefore, the necessary electrical and refrigeration information is also on the rating label, which can be easily seen by removing only the front panel of the icemaker.

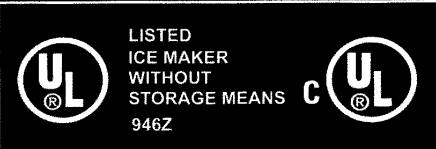
We reserve the right to make changes in specifications and design without prior notice.

[c] KML-600MRH (Remote air-cooled)

<b>HOSHIZAKI ICE MAKER</b>				
<b>MODEL NUMBER</b>	<b>KML-600MRH</b>			
<b>SERIAL NUMBER</b>				
<b>AC SUPPLY VOLTAGE</b>	<b>208-230/60/1 (3 WIRE WITH NEUTRAL FOR 115V)</b>			
<b>COMPRESSOR</b>	<b>208-230V</b>	<b>9.8RLA</b>	<b>56LRA</b>	
<b>PUMP</b>	<b>120V</b>	<b>0.54FLA</b>	<b>10W</b>	
<b>FAN</b>	<b>REMOTE</b>	<b>120V</b>	<b>3A</b>	<b>MAX</b>
<b>OTHER</b>	<b>115-120V</b>	<b>0.3A</b>		
<b>MAXIMUM FUSE SIZE</b>	<b>20 AMPS</b>			
<b>MAX. HACR BREAKER (USA ONLY)</b>	<b>20 AMPS</b>			
<b>MAX. CIRC. BREAKER (CANADA ONLY)</b>	<b>20 AMPS</b>			
<b>MINIMUM CIRCUIT AMPACITY</b>	<b>20 AMPS</b>			
<b>DESIGN PRESSURE</b>	<b>HI-467PSI LO-230PSI</b>			
<b>REFRIGERANT</b>	<b>404A</b>			
<b>MOTOR-COMPRESSOR THERMALLY PROTECTED</b>				
<b>NOT INTENDED FOR OUTDOOR USE</b>				
<b>HOSHIZAKI AMERICA, INC.</b> Peachtree City, GA				
   				
				

See the Nameplate for electrical and refrigeration specifications. This Nameplate is located on the upper right hand side of rear panel.

Since this Nameplate is located on the rear panel of the icemaker, it cannot be read when the back of the icemaker is against a wall or against another piece of kitchen equipment. Therefore, the necessary electrical and refrigeration information is also on the rating label, which can be easily seen by removing only the front panel of the icemaker.

We reserve the right to make changes in specifications and design without prior notice.

## 2. DIMENSIONS/CONNECTIONS

[a] KML-600MAH

Unit: inches (mm.)

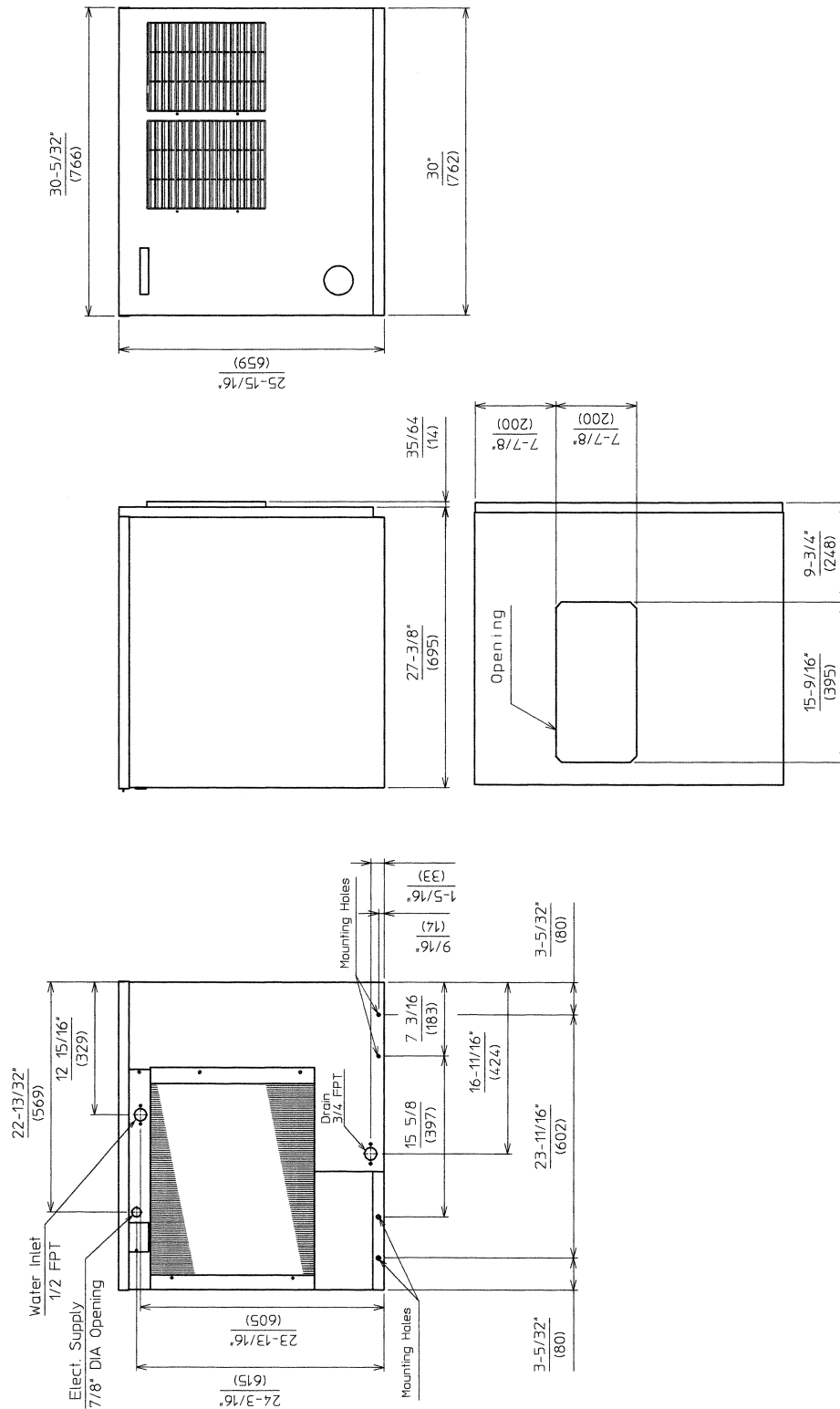

[b] KML-600MWH

Unit: inches (mm.)

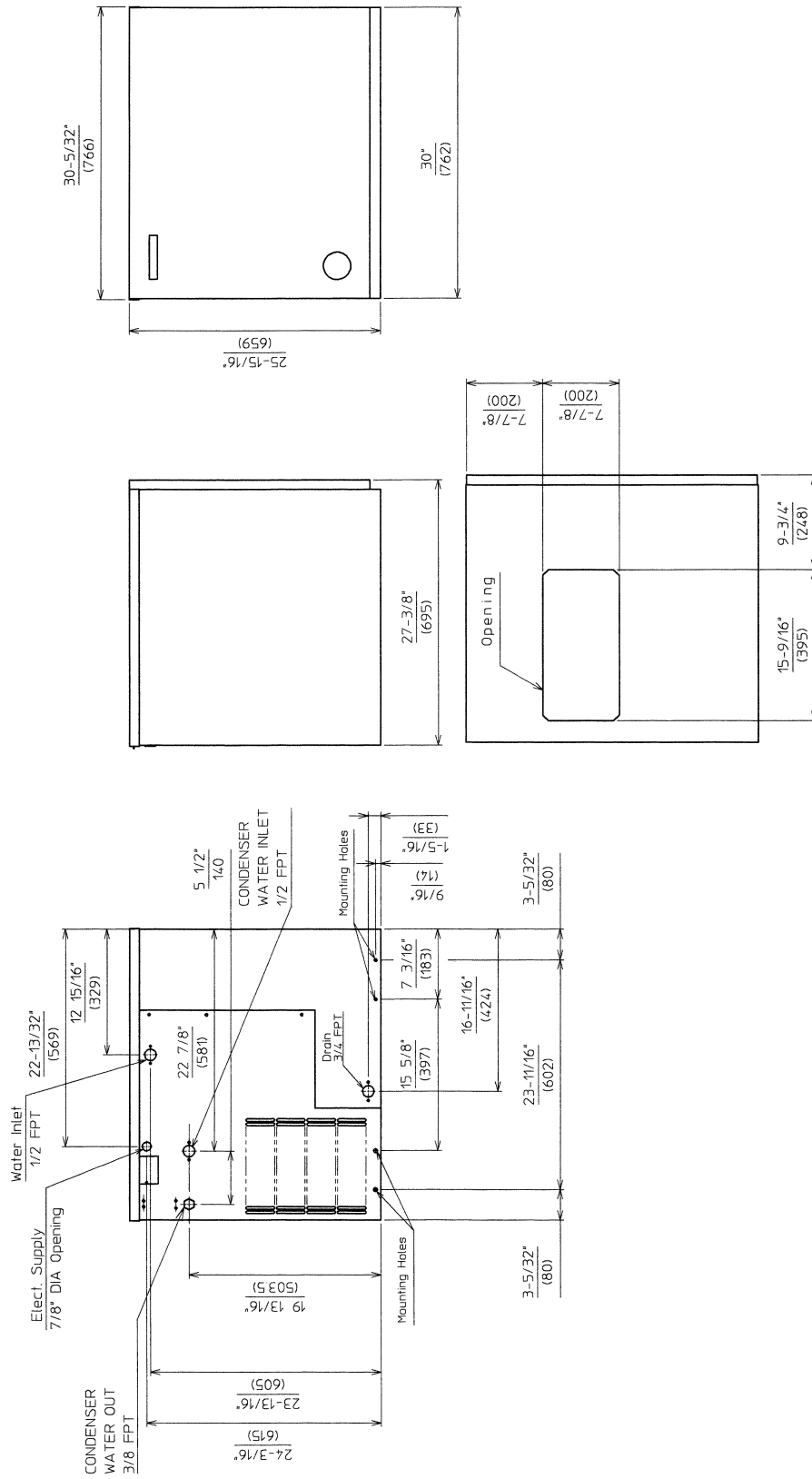



[c] KML-600MRH

Unit: inches (mm.)

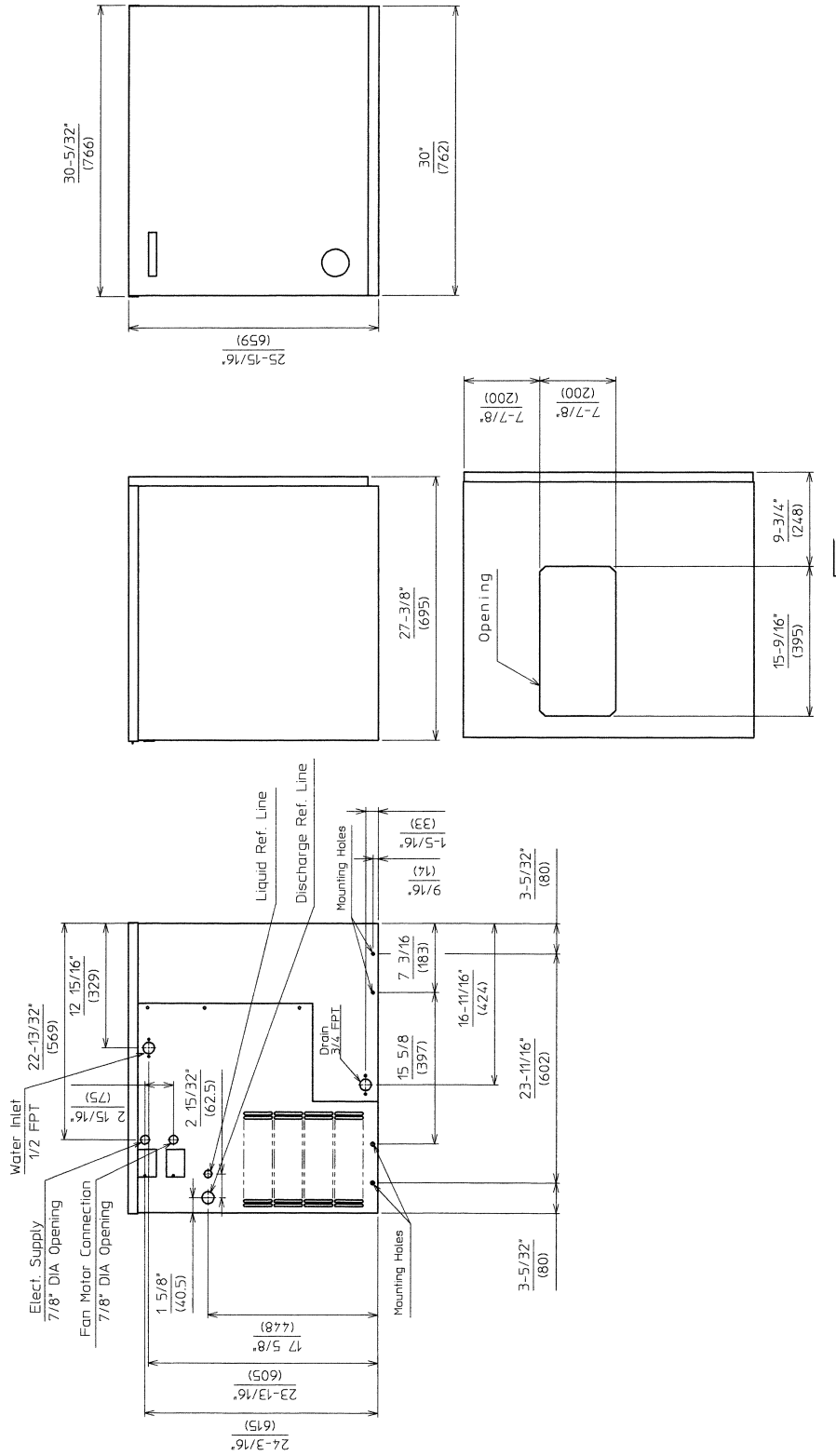

## II. INSTALLATION AND OPERATING INSTRUCTIONS

### 1. CHECKS BEFORE INSTALLATION

#### IMPORTANT

Remove shipping carton, tape(s) and packing. If packing material is left in the icemaker, it will not work properly.

- 1) Remove the panels to prevent damage when installing the icemaker. See “2. HOW TO REMOVE PANELS.”
- 2) Remove the package containing the accessories.
- 3) Release the Bin Switch assembly:
  - a) Remove the Bin Control Cover (See Fig. 1) to access the Bin Switch assembly.
  - b) Remove the shipping tape holding the switch actuator arm and paddle in place so that the paddle swings down freely.
  - c) Replace the Bin Control Cover.
- 4) Remove the protective plastic film from the panels. If the icemaker is exposed to the sun or to heat, remove the film after the icemaker cools.
- 5) Check that the refrigerant lines do not rub or touch lines or other surfaces, and that the fan blade turns freely.
- 6) Check that the Compressor is snug on all mounting pads.
- 7) See the Nameplate on the Rear Panel, and check that your voltage supplied corresponds with the voltage specified on the Nameplate.
- 8) This icemaker needs a storage bin. The recommended storage bin is HOSHIZAKI ICE STORAGE BIN, Model B-500 series, DB-200, or DM-180.
- 9) On remote air-cooled models, a remote condenser unit is needed. The recommended remote condenser unit is HOSHIZAKI CONDENSER UNIT, MODEL URC-7F.

## 2. HOW TO REMOVE PANELS - See Fig. 1

- a) Front Panel ..... Remove the screw.  
Lift up and pull toward you.
- b) Top Panel ..... Lift its front up slightly,  
push away, and then lift off.
- c) Side Panel (R) ..... Remove the screw.  
Pull slightly toward you,  
and lift off.
- d) Insulation Panel ... Lift up slightly, and pull  
toward you.

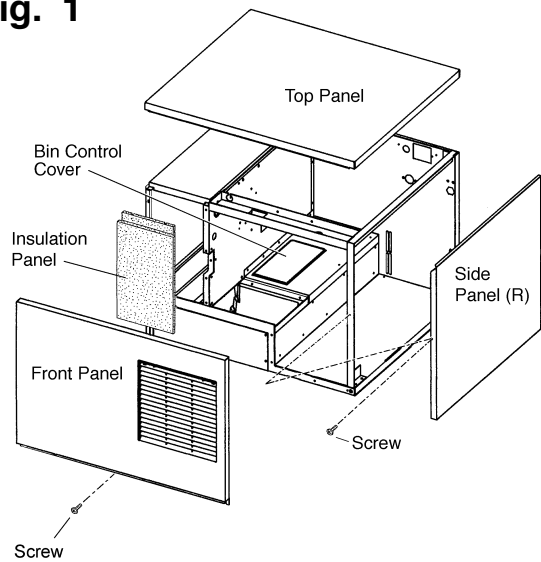

**Fig. 1**

## 3. LOCATION

### WARNING

This icemaker is not intended for outdoor use. Normal operating ambient temperature should be within +45°F to +100°F; Normal operating water temperature should be within +45°F to +90°F. Operation of the icemaker, for extended periods, outside of these normal temperature ranges may affect production capacity.

For best operating results:

- Icemaker should not be located next to ovens, grills or other high heat producing equipment.
- Location should provide a firm and level foundation for the equipment.
- Allow 6" clearance at rear, sides and top for proper air circulation and ease of maintenance and/or service should they be required.

## 4. SET UP

- 1) Unpack the Storage Bin, and attach the four adjustable legs provided (bin accessory) to the bottom of the Storage Bin.
- 2) Position the Storage Bin in the selected permanent position.
- 3) Place the icemaker on the top of the Storage Bin.
- 4) Secure the icemaker to the Storage Bin, by using the two Universal Braces and the two bolts provided. See Fig. 2
- 5) Level the icemaker/Storage Bin in both the left-to-right and front-to-rear directions. Adjust the Ice Bin Legs to make the icemaker level.
- 6) Replace the panels in their correct positions.

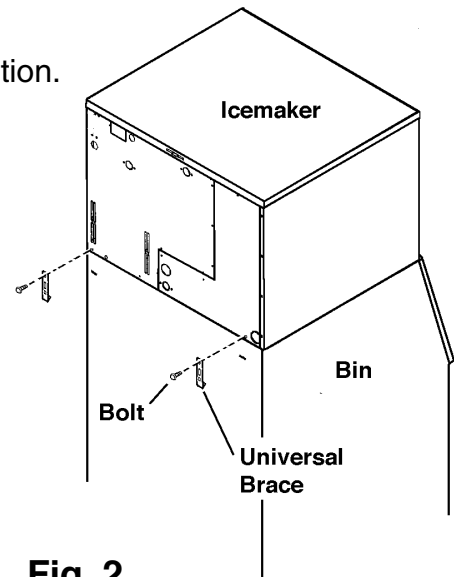

Fig. 2

## 5. ELECTRICAL CONNECTION

### WARNING

1. Electrical connection must be made in accordance with the instructions on the "WARNING" tag, provided with the pig tail leads in the Junction Box.
2. This icemaker requires a ground that meets the national and local electrical code requirements. To prevent possible electrical shock to individuals or extensive damage to the equipment, install a proper ground wire to the icemaker.

- The white lead must be connected to the neutral conductor of the power source. Miswiring results in severe damage to the icemaker. See Fig. 3.
- This icemaker must have a separate power supply or receptacle of proper capacity. See the Nameplate.
- The opening for the power supply connection is 7/8" diameter to fit a 1/2" trade size conduit.
- Usually an electrical permit and services of a licensed electrician are required.

### WARNING

#### ELECTRICAL CONNECTION

The white lead must be connected to the neutral conductor of the power source. Miswiring results in severe damage to the icemaker. (See Fig. below.)

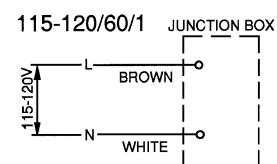

Fig. 3

## 6. INSTALLATION OF REMOTE CONDENSER UNIT

### [a] CHECKS BEFORE INSTALLATION

- 1) Unpack and remove shipping carton, tape(s) and packing.
- 2) Check that the refrigerant lines do not rub or touch lines or other surfaces, and that the fan blade turns freely.

### [b] LOCATION

The condenser unit must be positioned in a permanent site under the following guidelines.

- A firm and flat site.
- A dry and well ventilated area with 24" clearance on both front and rear for ease of maintenance and service should they be required.
- Normal condenser ambient temperature: -20°F to +122°F. Temperatures not within this operating range may affect the production capacity of the icemaker.
- The maximum line length for the standard refrigerant charge is 66 feet. Should an installation require a longer line length, please call 1-800-233-1940 for recommendations concerning the correct additional refrigerant charge to be added.

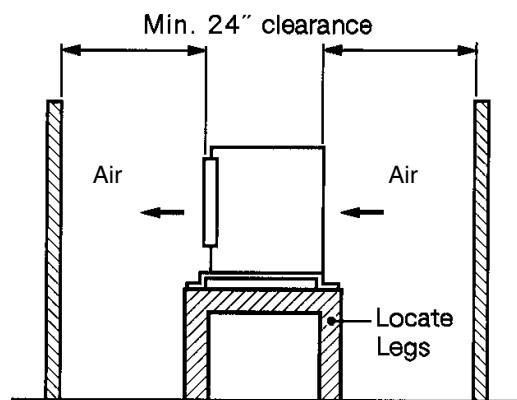

**Fig. 4**

Note: If the recommended guidelines of the installation are exceeded, the icemaker performance may be reduced.

## [c] SET UP

- 1) Secure the Legs to the condenser unit with eight M8 x 16 mm Hexagon Bolts and M8 Nuts as shown in the illustration. See Fig. 5.

Note: Locate the Legs symmetrically.

- 2) The Legs have eight mounting holes. Secure the Legs with eight bolts (not included).
- 3) Install enough length of two copper tubings provided with Aeroquip couplings between the icemaker and the condenser unit. The two copper tubings should be insulated separately. See Fig. 6.

- A connector kit “OS-QUICK” is available for field-fabricated lines from HOSHIZAKI AMERICA.

- R-404A precharged tubing kits, available as optional equipment also from HOSHIZAKI AMERICA, are recommended.

- 4) Line sets fabricated in the field should be evacuated through the charging ports on the Aeroquip couplings and charged with R-404A refrigerant vapor to a pressure of 15-30 PSIG.

Note: Factory fabricated tubing kits are precharged and do not need to be evacuated.

- 5) Remove the caution tape and plastic caps protecting the couplings. Attach the two refrigerant lines to the male couplings on the icemaker and the remote condenser unit. Each refrigerant line must be connected as follows:

Icemaker discharge refrigerant line - 3/8" OD tubing to “DIS” of condenser unit

Icemaker liquid refrigerant line - 1/4" OD tubing to “LIQ” of condenser unit

Note: Care should be taken that the unit, line set and Condenser contain the same type refrigerant prior to making connections. Mixing of refrigerants will result in improper operation and possible damage to the refrigeration system. Make the connections at the remote condenser first and then at the icemaker.

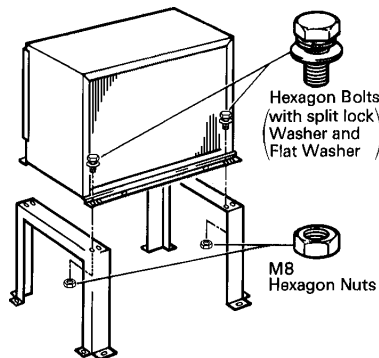

Fig. 5

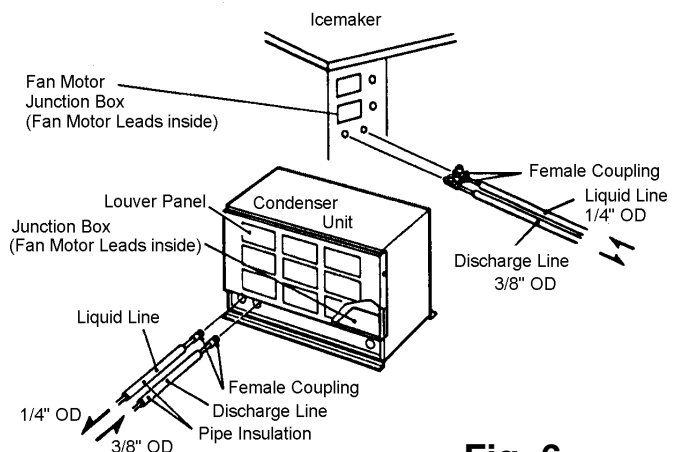

Fig. 6

## [d] ELECTRICAL CONNECTION

### WARNING

This remote condenser unit requires a ground that meets the national and local electrical code requirements. To prevent possible electrical shock to individuals or extensive damage to equipment, install a proper ground wire to this condenser unit.

- This condenser unit must be connected to the Fan Motor Junction Box on the icemaker.
  - The opening for the power supply connection is 7/8" DIA to fit a 1/2" trade size conduit.
  - Usually an electrical permit and services of a licensed electrician are required.
- 1) Remove the Panel.
  - 2) Remove the Junction Box Cover.
  - 3) Connect the Fan Motor leads in the Junction Box of the remote condenser unit to the Fan Motor leads in the Junction Box of the HOSHIZAKI remote air-cooled icemaker.
  - 4) Install a ground wire from the icemaker to the remote condenser unit.
  - 5) Place the Junction Box Cover and the Panel in position.

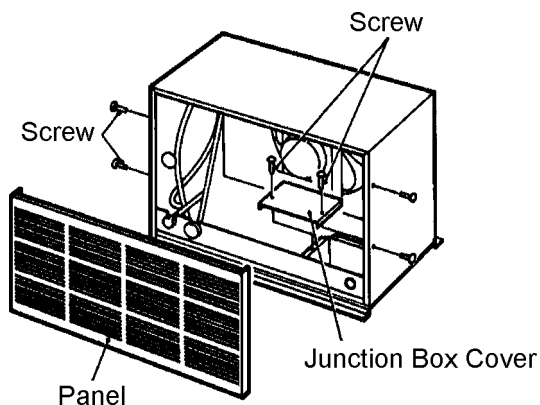

**Fig. 7**

### [e] STACKING CONDENSER UNIT

- 1) Secure the lower condenser unit to the Legs with eight bolts (not included).
- 2) Attach the upper condenser unit on the top of the lower.
- 3) Secure the upper condenser unit with the four screws provided.
- 4) Install refrigerant lines, and make electrical connection for each Fan Motor as shown in Items [c] and [d].

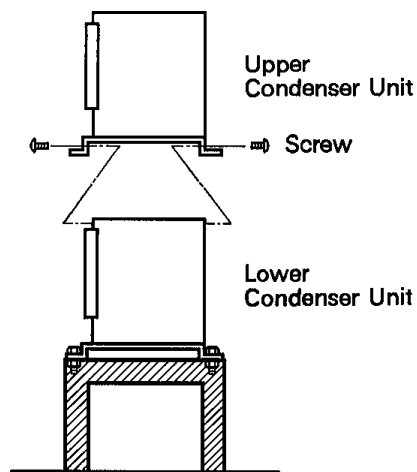

**Fig. 8**



## 7. WATER SUPPLY AND DRAIN CONNECTIONS - See Fig. 9

### IMPORTANT

Do not operate the icemaker when the water supply is OFF, or if the pressure is below 10 PSIG. Do not run the icemaker until the proper water pressure is reached.

- Water supply inlet is 1/2" female pipe thread (FPT).

Note: On water-cooled model, two water supply inlets are provided. One is for the ice making water inlet, and the other is for the cooling water inlet.

- A water supply line shut-off valve and drain valve should be installed. A minimum of 3/8" OD copper tubing is recommended for the water supply lines.

Note: An optional strainer should be installed next to the water supply inlet in the water supply line. HOSHIZAKI recommended optional strainer Part Code 311166A01.

- Water supply pressure should be a minimum of 10 PSIG and a maximum of 113 PSIG. If the pressure exceeds 113 PSIG, the use of a pressure reducing valve is required.
- Drain outlet for icemaker dump is 3/4" FPT. The icemaker drain must be made separately from the bin drain.

Note: On water-cooled model, a 3/8" FPT is provided for the condenser drain outlet.

- The drains must have 1/4" fall per foot on horizontal runs to get a good flow.
- The drains should not be piped directly to the sewer system. An air gap of a minimum of 2 vertical inches should be between the end of the drain pipe from the icemaker or the ice bin and the floor drain.
- This icemaker should be installed in accordance with applicable national, state and local regulations.
- A plumbing permit and services of a licensed plumber may be required in some areas.
- In some areas, a back flow preventer may be required in the cooling water circuit.

KML-600MAH  
KML-600MRH

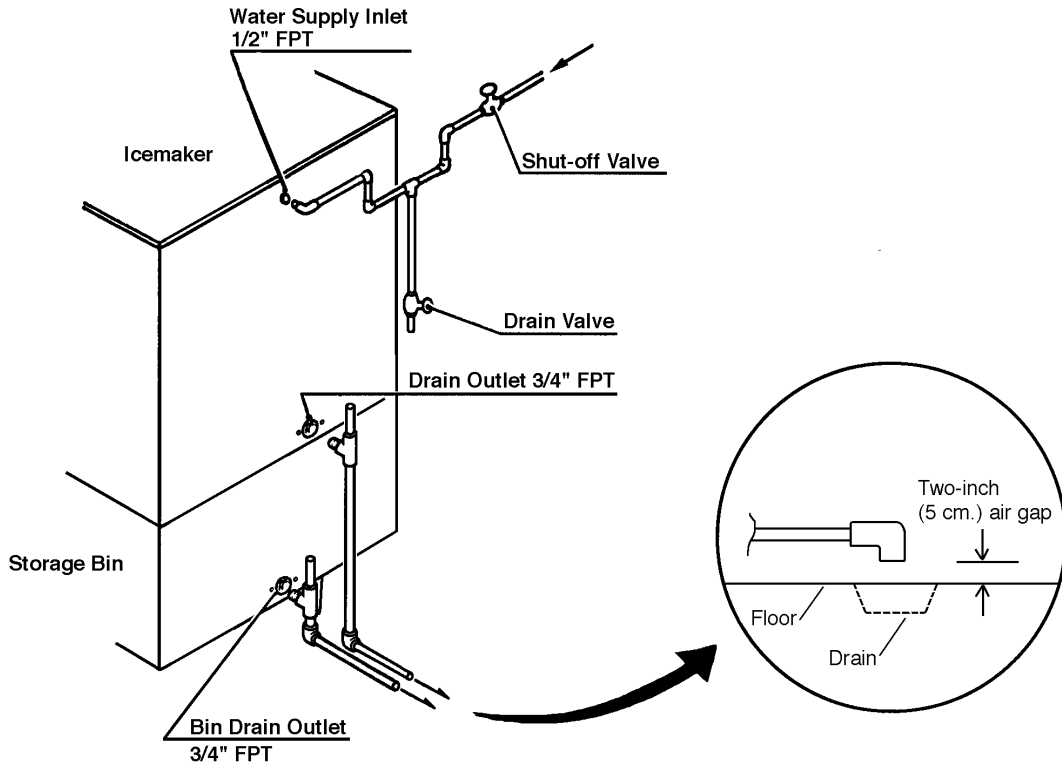

Separate piping to approved drain.  
Leave a two-inch (5 cm.) vertical air gap  
between the end of each pipe and  
the drain.

KML-600MWH

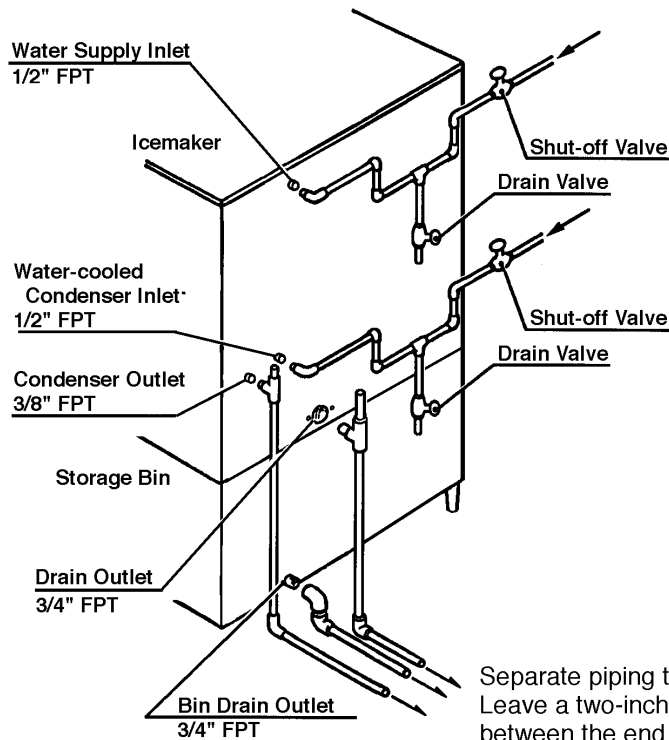

**Fig. 9**

Separate piping to approved drain.  
Leave a two-inch (5 cm.) vertical air gap  
between the end of each pipe and  
the drain.

## 8. FINAL CHECK LIST

- 1) Is the icemaker level?
- 2) Is the icemaker in a site where the ambient temperature is within +45°F to +100°F and the water temperature within +45°F to +90°F all year around?
- 3) Is there at least 6" clearance at sides, rear and top of the icemaker for maintenance or service?
- 4) Have the shipping carton and all tapes and packing been removed from the icemaker?
  - a) Is the cube guide in its correct position?
  - b) Does the Bin Switch assembly actuator arm and paddle swing freely?
- 5) Have all electrical and piping connections been made?
- 6) Has the power supply voltage been checked or tested against the nameplate rating? And has a proper ground been installed in the icemaker?
- 7) Are the Water Supply Line Shut-off Valve and Drain Valve installed? Has the water supply pressure been checked to ensure a minimum of 10 PSIG and a maximum of 113 PSIG?

Note: The icemaker may stop running when the water supply is OFF, or if the pressure is below 10 PSIG. When the proper water pressure is reached, the icemaker automatically starts running again.
- 8) Have the compressor hold-down bolts and refrigerant lines been checked against vibration and possible failure?
- 9) Has the end user been given the instruction manual, and instructed on how to operate the icemaker and the importance of the recommended periodic maintenance?
- 10) Has the end user been given the name and telephone number of an authorized service agent?
- 11) Has the warranty tag been filled out and forwarded to the factory for warranty registration?

## 9. START UP

### CAUTION

1. All parts are factory-adjusted. Improper adjustments may result in failure.
2. If the unit is turned off, wait for at least 3 minutes before restarting the icemaker to prevent damage to the Compressor.
3. Do not operate the unit in the "WASH" position without water in the Water Tank. This will cause damage to the Water Pump seal.

- 1) Open the Water Supply Line Shut-off Valve.
- 2) Remove the Front Panel.
- 3) Move the toggle Control Switch, on the Control Box, to the "ICE" position.
- 4) Replace the Front Panel in its correct position.
- 5) Turn on the power supply and allow the Water Tank to fill with water and the icemaker to operate for a total of 10 minutes.
- 6) Remove the Front Panel and the Bin Control Cover and turn the control switch to "OFF".
- 7) Check to assure that the Bin Switch shuts the unit down.
  - a) Turn the control switch to "ICE".
  - b) Allow the unit to cycle into the freeze mode. This occurs when the pump motor starts to supply water upwards, through the supply tube. After 1-2 minutes in freeze, move the bin switch paddle fully to the right. See Fig. 10.
  - c) The unit should shut down within 3-5 seconds.

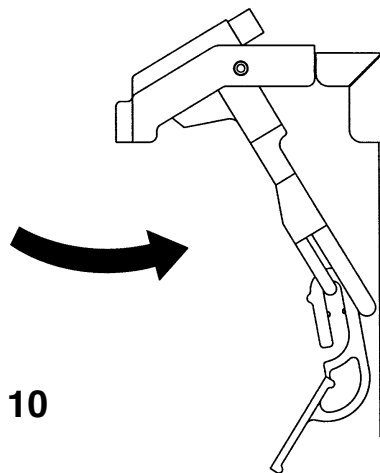

**Fig. 10**

Note: The Bin Switch will only shut down the unit at the end of a harvest or within the first 5 minutes of the freeze cycle. To shut the unit down outside of this time period turn the control switch to "OFF".

- 8) Replace the Bin Control Cover.
- 9) Move the Control Switch to the "Service" position. Then move the Service Switch to the "Drain" position.
- 10) Replace the Front Panel.
- 11) Turn on the power supply for 2 minutes to allow the icemaker to drain.
- 12) Turn off the power supply and remove the Front Panel.
- 13) Move the Control Switch, on the Control Box, to the "ICE" position.
- 14) Replace the Front Panel and turn on the power supply.

## 10. PREPARING THE ICEMAKER FOR LONG STORAGE

### CAUTION

When shutting off the icemaker for an extended time, drain out all water from the water line and remove the ice from the Storage Bin. The Storage Bin should be cleaned and dried. Drain the icemaker to prevent damage to the water supply line at sub-freezing temperatures, using air or carbon dioxide. Shut off the icemaker until the proper ambient temperature is resumed.

- When the icemaker is not used for two or three days, it is sufficient to only move the Control Switch to the “OFF” position, unless the icemaker will be at sub-freezing temperatures.

[1] On water-cooled model only, first remove the water from the water-cooled condenser:

- 1) Turn off the power supply.
- 2) Remove the Front Panel.
- 3) Move the Control Switch, on the Control Box, to the “OFF” position.
- 4) Wait 3 minutes.
- 5) Move the Control Switch to the “ICE” position.
- 6) Replace the Front Panel and turn on the power supply.
- 7) Allow 5 minutes for the icemaker to fill with water and the Water Pump to start operating.
- 8) Close the Water-cooled Condenser Water Supply Line Shut-off Valve. See Fig. 9.
- 9) Open the Drain Valve for the water-cooled condenser water supply line.
- 10) Allow the line to drain by gravity.
- 11) Quickly attach compressed air or carbon dioxide supply to the Condenser Water Line Drain Valve.
- 12) Blow the water-cooled Condenser out using compressed air or carbon dioxide until water stops coming out.

[2] Remove the water from the potable water supply line:

- 1) Turn off the power supply and remove the Front Panel.
- 2) Move the Control Switch, on the Control Box, to the “OFF” position.
- 3) Wait 3 minutes.
- 4) Close the Potable Water Supply Line Shut-off Valve and open the Potable Water Supply Line Drain Valve. See Fig. 9.
- 5) Allow the line to drain by gravity.
- 6) Attach compressed air or carbon dioxide supply to the Potable Water Line Drain Valve.
- 7) Move the Control Switch to the “ICE” position.
- 8) Replace Front Panel and turn on the power supply.
- 9) Blow the potable water line out using compressed air or carbon dioxide.

[3] Drain the Potable Water Tank:

- 1) Turn off the power supply.
- 2) Remove the Front Panel.
- 3) Move the Control Switch to “SERVICE” and move the Service Switch to the “DRAIN” position.
- 4) Replace the Front Panel and turn on the power supply for 2 minutes.
- 5) Turn off the power supply.

### III. CLEANING AND MAINTENANCE INSTRUCTIONS

#### 1. CLEANING

##### WARNING

1. HOSHIZAKI recommends cleaning this unit at least once a year. More frequent cleaning, however, may be required in some existing water conditions.
2. To prevent injury to individuals and damage to the icemaker, do not use ammonia type cleaners.
3. Always wear liquid-proof gloves for safe handling of the cleaning and sanitizing solution. This will prevent irritation in case the solution contacts with skin.

#### [a] CLEANING PROCEDURE

- 1) Dilute approximately 13.5 fl. oz. of recommended cleaner Hoshizaki "Scale Away" or "LIME-A-WAY," (Economics Laboratory, Inc.) with 2.5 gal. of water.
- 2) Remove all ice from the Evaporator and the Storage Bin.

Note: To remove cubes on the Evaporator, turn off the power supply and turn it on after 3 minutes. The defrost cycle starts and the cubes will be removed from the Evaporator.

- 3) Turn off the power supply.
- 4) Remove the Front Panel.
- 5) Place the Control Switch in the "SERVICE" position. Then place the Service Switch in the "DRAIN" position.
- 6) Replace the Front Panel and turn on the power supply for 2 minutes.
- 7) Turn off the power supply.
- 8) Remove the Front Panel and then remove the Insulation Panel by lifting up the panel slightly and pulling it toward you.
- 9) Pour the cleaning solution into the Water Tank.



- 10) Move the Service Switch to the "WASH" position.
- 11) Replace the Insulation Panel and the Front Panel in their correct positions.
- 12) Turn on the power supply and start the washing process.
- 13) Turn off the power supply after 30 minutes.
- 14) Remove the Front Panel.
- 15) Move the Service Switch to the "DRAIN" position.
- 16) Replace the Front Panel and turn on the power supply for 2 minutes.
- 17) Turn off the power supply and remove the Front Panel.
- 18) Move the Control Switch to the "ICE" position.
- 19) Replace the Front Panel in its correct position.
- 20) Turn on the power supply to fill the Water Tank with water.
- 21) Turn off the power supply after 3 minutes.
- 22) Remove the Front Panel.
- 23) Move the Control Switch to the "SERVICE" position; then move the Service Switch to the "WASH" position
- 24) Replace the Front Panel in its correct position.
- 25) Turn on the power supply to rinse off the cleaning solution.
- 26) After 5 minutes, turn off the power supply.
- 27) Remove the Front Panel.
- 28) Move the Service Switch to the "DRAIN" position.
- 29) Replace the Front Panel and turn on the power supply for 2 minutes.
- 30) Turn off the power supply.

31) Remove the Front Panel.

31) Repeat the above steps 18) through 31) three more times to rinse thoroughly.

Note: If you do not sanitize the icemaker, go to step 14) in “SANITIZING PROCEDURE.”

**[b] SANITIZING PROCEDURE - Following Cleaning Procedure**

1) Dilute IMS-II Sanitizer or a 5.25% Sodium Hypochlorite solution with water (Add 1.25 fl. oz. to 2.5 gal. of water).

Note: IMS-II Sanitizer, Part #SA0004, is available through your Hoshizaki Dealer.

2) Remove the Insulation Panel.

3) Pour the sanitizing solution into the Water Tank.

4) Move the Service Switch to the “WASH” position.

5) Replace the Insulation Panel and the Front Panel in their correct position.

6) Turn on the power supply and start the sanitizing process.

7) Turn off the power supply after 15 minutes.

8) Remove the Front Panel.

9) Move the Service Switch to the “DRAIN” position.

10) Replace the Front Panel and turn on the power supply for 2 minutes.

11) Turn off the power supply.

12) Remove the Front Panel.

13) Repeat the above steps 18) through 31) in “CLEANING PROCEDURE” two times to rinse thoroughly.

14) Move the Control Switch to the “ICE” position.

15) Replace the Front Panel in its correct position.

16) Clean the Storage Bin with water.

17) Turn on the power supply and start the automatic icemaking process.

## 2. MAINTENANCE

### IMPORTANT

This icemaker must be maintained individually, referring to the instruction manual and labels provided with the icemaker.

#### 1) Stainless Steel Exterior

To prevent corrosion, wipe the exterior occasionally with a clean and soft cloth. Use a damp cloth containing a neutral cleaner to wipe off oil or dirt build up.

#### 2) Storage Bin and Scoop

- Wash your hands before removing ice. Use the plastic scoop provided (Accessory).
- The Storage Bin is for ice use only. Do not store anything else in the bin.
- Keep the scoop clean. Clean it by using a neutral cleaner and rinse thoroughly.
- Clean the bin liner by using a neutral cleaner. Rinse thoroughly after cleaning.

#### 3) Air Filter (Air-cooled model only)

A plastic mesh air filter removes dirt or dust from the air, and keeps the Condenser from getting clogged. As the filter gets clogged, the icemaker's performance will be reduced. Check the filter at least twice a month. When clogged, use warm water and a neutral cleaner to wash the filter.

#### 4) Condenser (Except Water-cooled model)

Check the Condenser once a year, and clean if required by using a brush or vacuum cleaner. More frequent cleaning may be required depending on the location of the icemaker.

# **HOSHIZAKI**

**HOSHIZAKI AMERICA, INC.**

618 HIGHWAY 74 SOUTH  
PEACHTREE CITY, GA 30269  
U.S.A.  
PHONE: 770-487-2331