

Hoshizaki America, Inc.

Low-Profile Modular Crescent Cuber

Model
KML-700MWH-M



“A Superior Degree
of Reliability”

www.hoshizaki.com

PARTS LIST



Number: 71336
Issued: 7-7-2011

CONTENTS

Auxiliary Codes.....	3
Note About Ordering Parts	3
A. Ice Cuber Assembly and Refrigeration Circuit.....	4
B. Water Circuit	7
C. Control Box Assembly	9
D. Label Location	10
E. Accessories & Packaging	11

Auxiliary Codes

KML-700MWH-M	U-0	October 2009
	A-0	April 2011
	A-1	TBD

Auxiliary Code Breakdown

The auxiliary code is the first two characters in the serial number. The first character indicates the year. Years progress or regress in alphabetical order. The series runs from "A" through "V" and the letters "I" and "O" are skipped. The second character indicates significant part changes within a year. Base is "0" and this number advances for each change. In cases where there is a letter in parentheses, this designates the month. This is the last character in the serial number. The series runs from "(A)" through "(M)" and the letter "(I)" is skipped. This designation is only included when identifying a parts change within an auxiliary code.

Note About Ordering Parts

Most assemblies cannot be ordered as complete units; parts in the assemblies generally must be ordered separately.

A. Ice Cuber Assembly and Refrigeration Circuit

KML-700MWH-M

U-0 to A-1

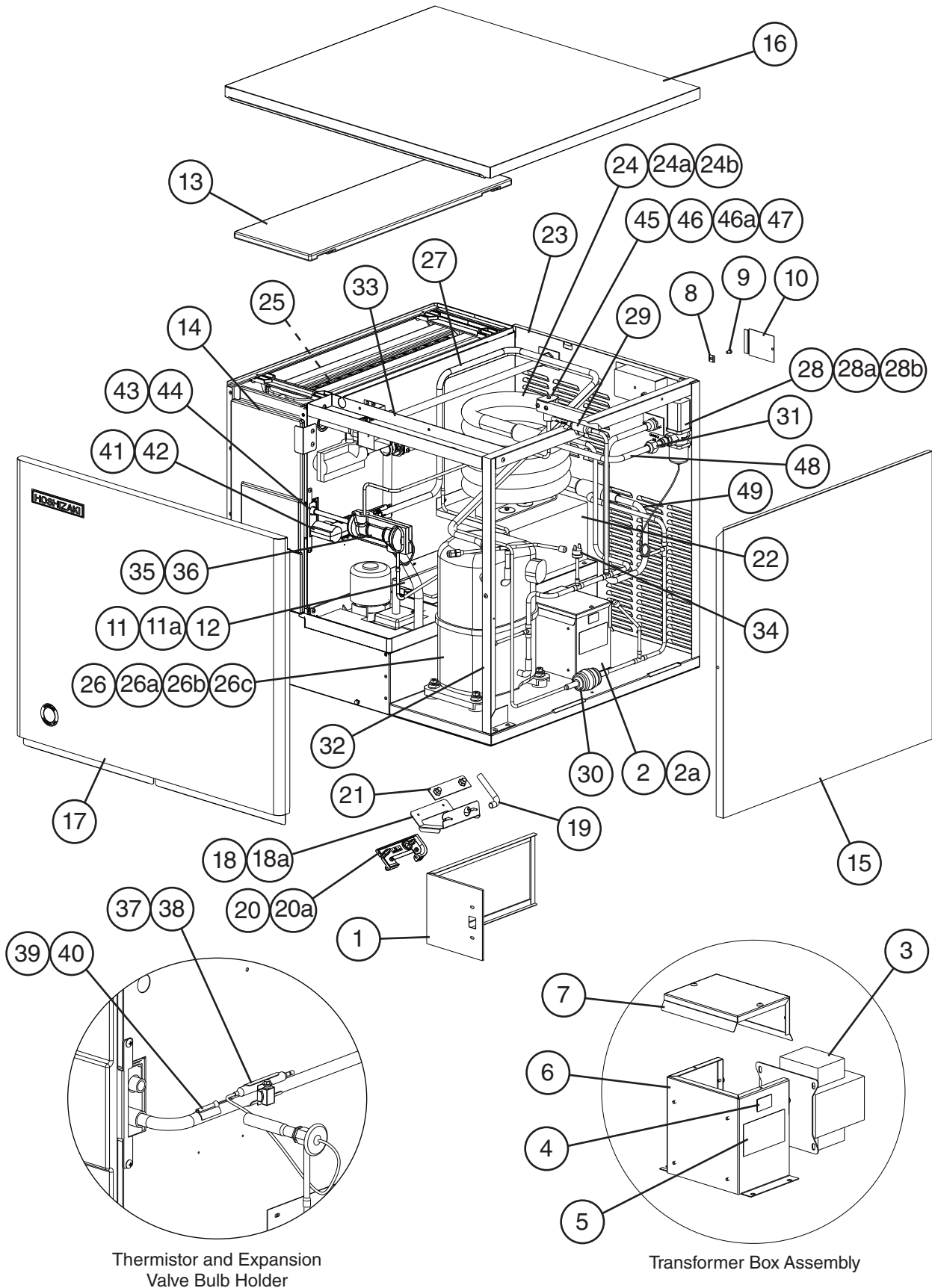

Title: A. Ice Cuber Assembly and Refrigeration Circuit Model: KML-700MWH-M														
Index No.	Description	Material or Model Number	Part Number	U-0 to A-1	Required Number									
Ice Cuber Assembly			1A1710A01	1										
Order Assembly Parts Individually														
1	Control Box Cover		3A5204G01	1										
2	Transformer Box Assembly (includes items 3 through 7)		3A1102A02	1										
2a	Hex Head Bolt w/Washer	5x10, SS	7B0230510	4										
3	Transformer		4A0817-01	1										
4	Voltage Tap Switch		4A1477-01	1										
5	Voltage Tap Switch Label		439423-01	1										
6	Transformer Box		3A1101-02	1										
7	Transformer Box Cover		4A4304-01	1										
8	Square Washer		433537-02	1										
9	Ground Screw		433304-02	1										
10	Junction Box Cover		433410-05	1										
11	Bin Control Cover		3A0664G01	1										
11a	Thumbscrew		415949G08	2										
12	Capillary Ring		425307-01	1										
13	Top Insulation		215730G01	1										
14	Front Insulation		2A0664G02	1										
15	Right Side Panel		2A2114G01	1										
16	Top Panel		3A1862A01	1										
17	Front Panel		3A4001A02	1										
18	Thermostat Extension Bracket		4A4358-01	1										
18a	Thumbscrew		415949G10	2										
19	Silicone Hose	L=310	7730I3812	1										
20	Bulb Holder		3A3903-01	1										
20a	Thumbscrew		415949G11	2										
21	NSF Plate		4A4401G01	1										
Refrigeration Circuit			1A1683A01	1										
Order Assembly Parts Individually														
22	Condenser Support		2A4880-01	1										
23	Rear Panel		3A3912G02	1										
24	Condenser		3A5124-01	1										
24a	Hex Head Bolt	5x14, SS	7B02-0514	2										
24b	Washer		4A5063-01	2										
25	Evaporator		106492G01	1										
26	Compressor		4A4066-01	1										
26a	Spacer		434921-01	4										
26b	Grommet		434922-01	4										
26c	Bolt	8x45	437889-04	4										
27	Heat Exchanger		2A4882G01	1										
28	Water Regulating Valve		4A0911-07	1										
28a	Hex Head Bolt	4x8, SS	7B02-0408	2										
28b	Washer		4A4786-01	2										
29	Strainer		441569-02	1										
30	Drier		4A2666-01	1										
31	Male Connector		4A1087-01	1										

Title: A. Ice Cuber Assembly and Refrigeration Circuit Model: KML-700MWH-M													
Index No.	Description	Material or Model Number	Part Number	U-0 to A-1	Required Number								
32	Frame A		2A1153-03	1									
33	Frame B		3A0595-02	1									
34	High-Pressure Switch		463180-05	1									
35	Thermostatic Expansion Valve		4A1482-01	1									
36	Thermostatic Expansion Valve Cover		3A0944-01	1									
37	Thermostatic Expansion Valve Bulb Holder		3A0107-01	1									
38	Clamp		443461-02	1									
39	Thermistor		429006-03	1									
40	Thermistor Holder		427430-01	1									
41	Thermistor Insulation A		439368-01	1									
42	Thermistor Insulation B		439368-02	1									
43	Insulation Holder		3A1084-01	1									
44	Insulated Rubber Tube		4A1008G01	1									
45	Hot Gas Valve Bracket		442162-02	1									
46	Valve Coil (includes item 46a)		4A3277-01	1									
46a	Bolt		4A3277F01	1									
47	Hot Gas Valve Body		4A3978-01	1									
48	Condenser Outlet		3A5198G01	1									
49	Condenser Inlet		3A5197G01	1									

B. Water Circuit
KML-700MWH-M
U-0 to A-1

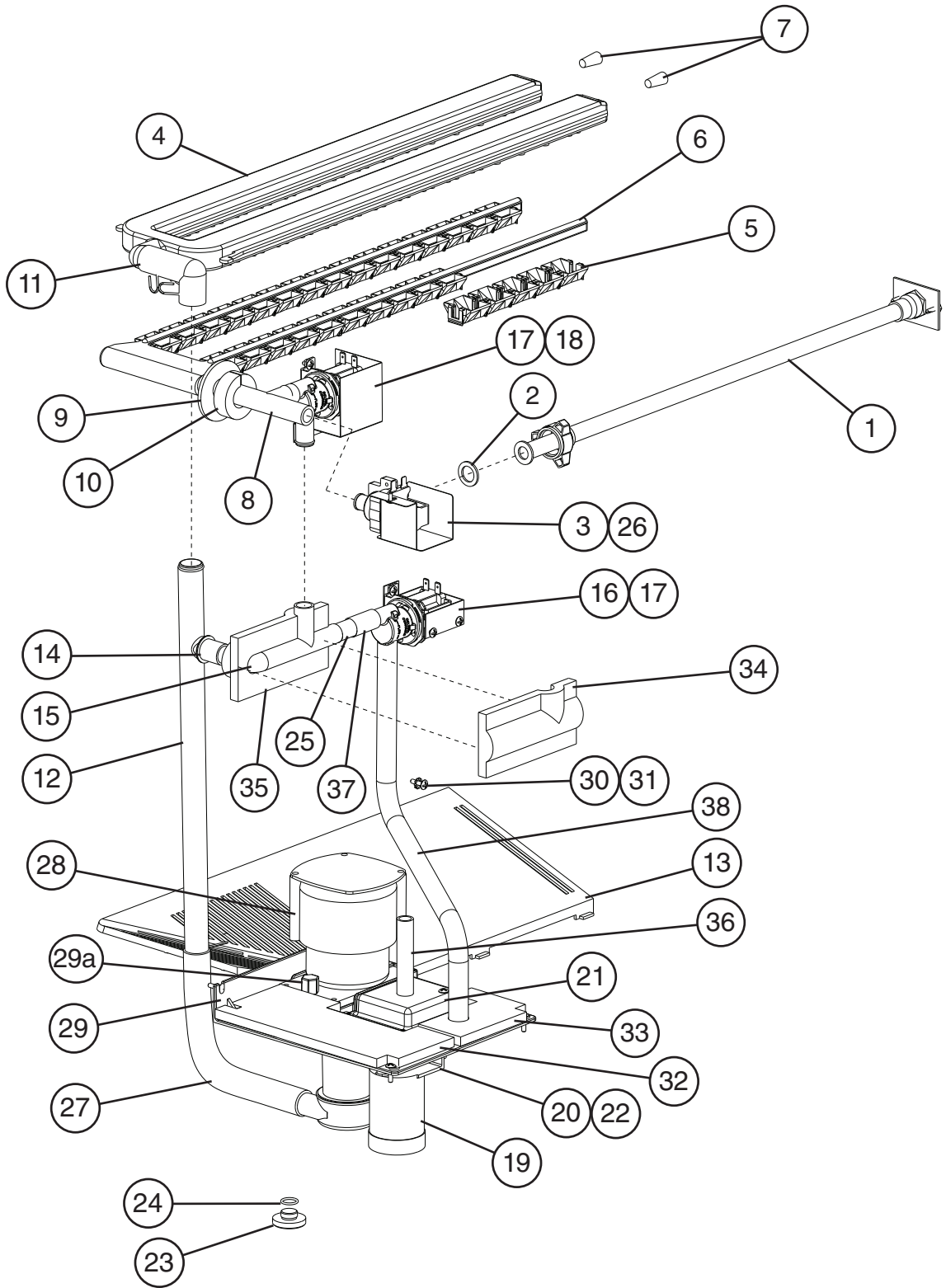

Title: B. Water Circuit Model: KML-700MWH-M											
Index No.	Description	Material or Model Number	Part Number	U-0 to A-1	Required Number						
Water Circuit			2A3782A02	1							
Order Assembly Parts Individually											
1	Water Supply Pipe		4A0768G04	1							
2	Rubber Gasket		413854-03	1							
3	Water Valve Bracket		321443-02	1							
4	Spray Tube		1A0260-02	1							
5	Spray Guide		208586-01	6							
6	Water Supply Tube		2A0079-01	1							
7	Plug		4A0176-01	2							
8	Water Supply Tee		4A1006-01	1							
9	Flange		439267-01	1							
10	Insulation E		4A0392-01	1							
11	Elbow		4A0393-01	1							
12	Connecting Pipe		3A1335-02	1							
13	Cube Guide		2A0660-01	1							
14	Rubber Ring		4A1004-01	1							
15	Bypass Hose		4A1005-01	1							
16	Drain Valve Bracket		4A3137-02	1							
17	Drain/Wash Valve		4A3722-01	2							
18	Wash Valve Cover		4A0996-02	1							
19	Float Switch		4A3624-01	1							
20	Float Switch Bracket		327757-01	1							
21	Float Switch Cover		3A0665-01	1							
22	Float Switch Spacer		4A0650-01	1							
23	Drain		309246-01	1							
24	"O" Ring		7611-P015	1							
25	Joint Pipe		439329-01	1							
26	Inlet Water Valve		3U0111-04	1							
27	Hose B		325867-01	1							
28	Pump Motor		4A4259-01	1							
29	Pump Motor Bracket		2A4920G01	1							
29a	Thumbscrew		415949G11	1							
30	T2 Screw (pump motor ground)	4x8, SS	7P32-0408	1							
31	Tooth Washer (pump motor ground)	M4, SS	7R22-0400	1							
32	Insulation A		4A4783-01	1							
33	Insulation B		4A1053-01	1							
34	Insulation A1		4A1259-01	1							
35	Insulation A2		4A1260-01	1							
36	Vinyl Hose	L=150	7716-1216	1							
37	Vinyl Hose	L=55	7716-1519	1							
38	Vinyl Hose	L=415	7716-1519	1							
Hose Clamps											
	Hose Clamp	25mm, SS	427443-03	4							
	Hose Clamp	18mm, SS	427443-05	9							
	Hose Clamp	20mm, SS	427443-06	1							

C. Control Box Assembly

KML-700MWH-M

U-0 to A-1

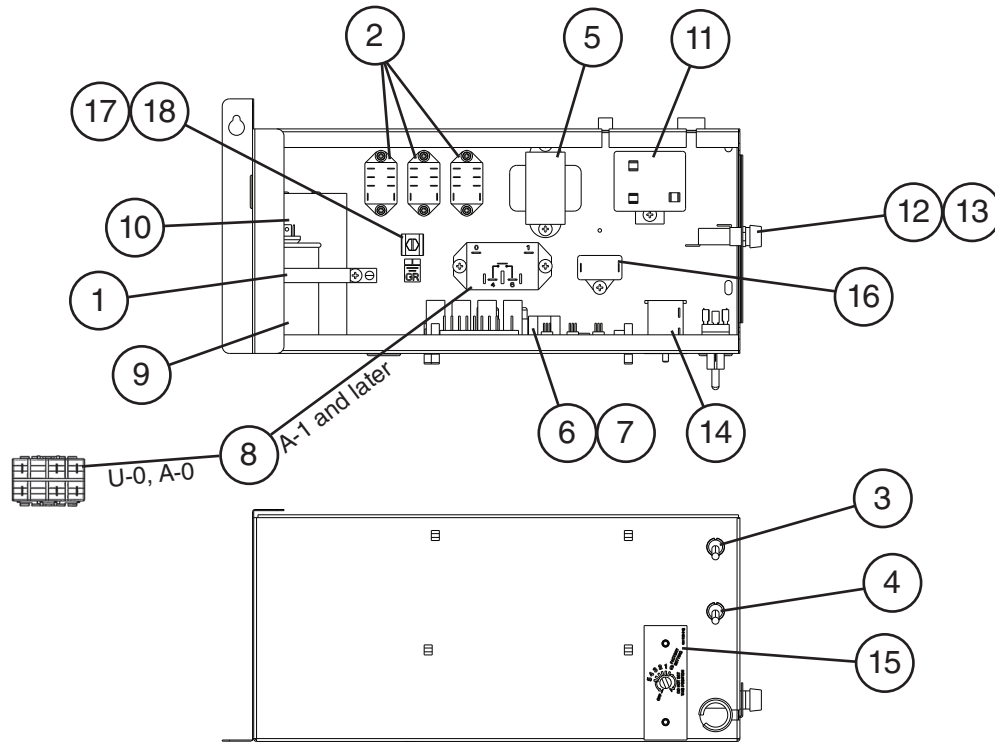

Title: C. Control Box Assembly Model: KML-700MWH-M															
Index No.	Description	Material or Model Number	Part Number	Required Number											
				U-0	A-0	A-1									
Control Box Assembly			2A4965A01	1	-										
Order Assembly Parts Individually			2A4965A02		1										
1	Strap		4A2262-06	1	1										
2	X10, X11, X12 Relay		406132-07	3	3										
3	Control Switch		443119-01	1	1										
4	Service Switch		4A0985-01	1	1										
5	Control Transformer		3A0172-01	1	1										
6	Control Board		2A3792-01	1	1										
7	Control Board Support		4A0336-03	4	4										
8	Magnetic Contactor		428393-01	1	-										
	Compressor Relay		4A3140-01		1										
9	Run Capacitor	30MFD, 370VAC	3A2005-03	1	1										
10	Start Capacitor	145-175MFD, 250VAC	3A0076-01	1	1										
11	Start Relay		4A1107-09	1	1										
12	Fuse		4A0893-07	1	1										
13	Fuse Holder		4A3449-01	1	1										
14	Thermostat		4A2879-01	1	1										
15	Control Label		4A1758-01	1	1										
16	Pump Motor Capacitor	2.5MFD, 250VAC	4A2128-05	1	1										
17	Ground Screw		433304-02	1	1										
18	Square Washer		433537-02	1	1										

D. Label Location
KML-700MWH-M
 U-0 to A-1

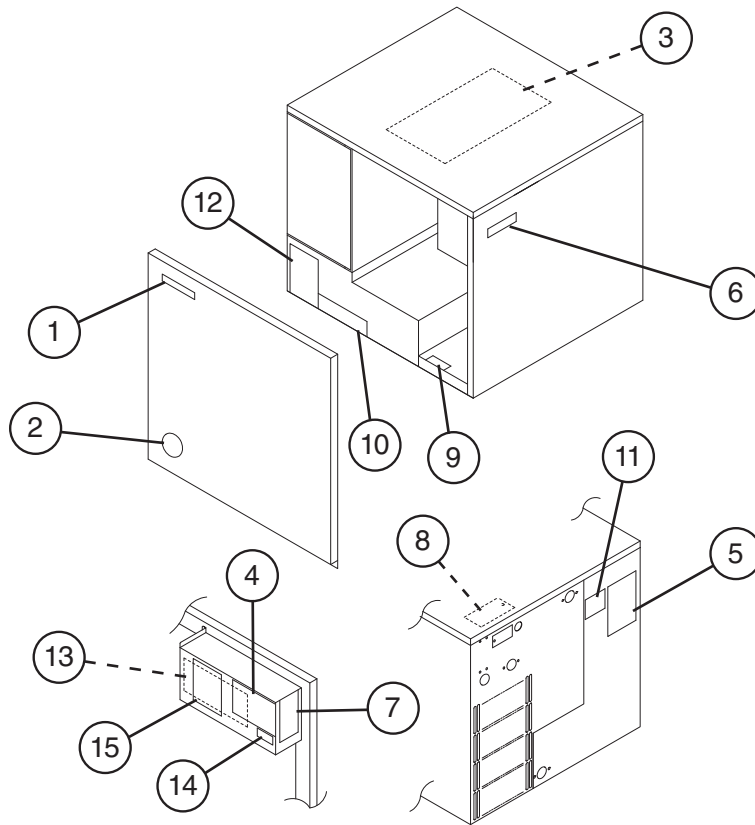

Title: D. Label Location Model: KML-700MWH-M																	
Index No.	Description	Material or Model Number	Part Number	Required Number													
				U-0	A-0	A-1											
Label Location			3A5208A01	1	1												
Order Assembly Parts Individually																	
1	Emblem		4A0560-01	1	1												
2	Penguin Label		4A0526-01	1	1												
3	Maintenance Label		3A5223-01	1	1												
4	Wiring Label		3A5248-01	1	-												
			3A6730-01		1												
5	Nameplate		2A3843-04	1	1												
6	Vessel Label		4A4006-01	1	1												
7	Manual Label		4A4735-01	1	1												
8	Tag Warning: Electrical Connection		4A4741-01	1	1												
9	R404A Label		4A0960-01	1	-												
10	Warning Label K		4A4736-01	1	1												
11	Instruction Label		444575-01	1	1												
12	Rating Label		2A3844-04	1	1												
13	Control Board Label		3A4799-01	1	1												
14	Fuse Label		4A2817-01	1	1												
15	Alarm Label		4A4737-01	1	1												

E. Accessories & Packaging

KML-700MWH-M

U-0 to A-1

Title: E. Accessories & Packaging Model: KML-700MWH-M											
Index No.	Description	Material or Model Number	Part Number	Required Number							
				U-0 to A-1							
1	Instruction Manual		91A1HL10A	1							
2	Universal Brace		4A0363-02	2							
2a	Hex Head Bolt	5x12, SS	7B02-0512	2							
	Packaging		2A2126A02	1							