



HOSHIZAKI

Instruction Manual

Modular Crescent Cuber
Serenity Series

Models

KMS-1122MLH with SRK-12H/3



hoshizakiamerica.com

Issued: 6-19-2014
Revised: 8-15-2017

⚠ WARNING

Only qualified service technicians should install and service the appliance. To obtain the name and phone number of your local Hoshizaki Certified Service Representative, visit www.hoshizaki.com. No installation or service should be undertaken until the technician has thoroughly read this Instruction Manual. Likewise, the owner/manager should not proceed to operate the appliance until the installer has instructed them on its proper operation. Failure to install, operate, and maintain the appliance in accordance with this manual will adversely affect safety, performance, component life, and warranty coverage and may result in costly water damage. Proper installation is the responsibility of the installer. Product failure or property damage due to improper installation is not covered under warranty.

Hoshizaki provides this manual primarily to assist qualified service technicians in the installation, maintenance, and service of the appliance.

Should the reader have any questions or concerns which have not been satisfactorily addressed, please call, send an e-mail message, or write to the Hoshizaki Technical Support Department for assistance.

Phone: 1-800-233-1940; (770) 487-2331

Fax: 1-800-843-1056; (770) 487-3360

E-mail: techsupport@hoshizaki.com

HOSHIZAKI AMERICA, INC.

618 Highway 74 South

Peachtree City, GA 30269

Attn: Hoshizaki Technical Support Department

NOTE: To expedite assistance, all correspondence/communication **MUST** include the following information:

- Model Number _____
- Serial Number _____
- Complete and detailed explanation of the problem.

IMPORTANT

This manual should be read carefully before the appliance is installed and operated. Read the warnings and guidelines contained in this manual carefully as they provide essential information for the continued safe use and maintenance of the appliance. Retain this manual for any further reference that may be necessary.

CONTENTS

Important Safety Information	4
I. Specifications.....	6
A. Electrical and Refrigerant Data	6
1. KMS-1122MLH	6
2. SRK-12H/3.....	6
B. Dimensions/Connections	7
1. KMS-1122MLH	7
2. SRK-12H/3.....	8
II. Installation and Operating Instructions	9
A. Location	9
1. Icemaker	9
2. Remote Condensing Unit.....	10
B. Checks Before Installation.....	11
1. Icemaker	11
2. Remote Condensing Unit.....	11
C. How to Remove Panels.....	12
1. Icemaker	12
2. Remote Condensing Unit.....	12
D. Setup.....	13
1. Dispenser Unit/Ice Storage Bin and Icemaker Setup	13
2. Bin Control	15
E. Installation of the Remote Condensing Unit.....	16
1. Setup.....	16
2. Line Set	16
a) Factory Line Set Installation	18
b) Field Fabricated Line Set Installation.....	19
F. Electrical Connection	21
G. Water Supply and Drain Connections	24
H. Final Checklist.....	26
I. Startup.....	27
III. Maintenance	29
A. Maintenance Schedule.....	29
B. Cleaning and Sanitizing Instructions	30
1. Cleaning Procedure.....	30
2. Sanitizing Procedure - Following Cleaning Procedure	31
IV. Preparing the Icemaker for Periods of Non-Use	33
V. Disposal	34

Important Safety Information

Throughout this manual, notices appear to bring your attention to situations which could result in death, serious injury, damage to the appliance, or damage to property.

⚠ WARNING Indicates a hazardous situation which could result in death or serious injury.

NOTICE Indicates a situation which could result in damage to the appliance or property.

IMPORTANT Indicates important information about the installation, use, and care of the appliance.

⚠ WARNING

This appliance should be destined only to the use for which it has been expressly conceived. Any other use should be considered improper and therefore dangerous. The manufacturer cannot be held responsible for injury or damage resulting from improper, incorrect, and unreasonable use. Failure to install, operate, and maintain the appliance in accordance with this manual will adversely affect safety, performance, component life, and warranty coverage and may result in costly water damage.

To reduce the risk of death, electric shock, serious injury, or fire, follow basic precautions including the following:

- Only qualified service technicians should install and service the appliance.
- The appliance must be installed in accordance with applicable national, state, and local codes and regulations.
- To reduce the risk of electric shock, do not touch the control switch or service switch with damp hands.
- Move the control switch to the "OFF" position and turn off the power supply to the remote condensing unit before servicing. Place the icemaker disconnect (if applicable) in the "OFF" position. Lockout/Tagout to prevent the power supply from being turned back on inadvertently.
- Do not make any alterations to the appliance. Alterations could result in electric shock, injury, fire, or damage to the appliance.
- This appliance is not intended for use by persons (including children) with reduced physical, sensory, or mental capabilities, or lack of experience and knowledge, unless they have been given supervision or instruction concerning use of the appliance by a person responsible for their safety.
- Children should be properly supervised around this appliance.
- Do not climb, stand, or hang on the appliance or allow children or animals to do so. Serious injury could occur or the appliance could be damaged.
- Do not use combustible spray or place volatile or flammable substances near the appliance. They might catch fire.
- Keep the area around the appliance clean. Dirt, dust, or insects in the appliance could cause harm to individuals or damage to the appliance.

⚠ WARNING, continued

Icemaker

- Do not connect the icemaker to an external power source. Icemaker power supply and ground connection are supplied from the remote condensing unit via the wire bundle provided with the remote condensing unit.
- Wire bundle routing (conduit) and disconnect (if required) must meet national, state, and local electrical code requirements. Failure to meet these code requirements could result in death, electric shock, serious injury, fire, or damage.
- **THE ICEMAKER MUST BE GROUNDED.** Failure to properly ground the icemaker could result in death or serious injury.

Remote Condensing Unit

- Remote condensing unit electrical connection must be hard-wired and must meet national, state, and local electrical code requirements. Failure to meet these code requirements could result in death, electric shock, serious injury, fire, or damage.
- The remote condensing unit requires an independent power supply of proper capacity. See the nameplate for electrical specifications. Failure to use an independent power supply of proper capacity can result in a tripped breaker, blown fuse, damage to existing wiring, or component failure. This could lead to heat generation or fire.
- **THE REMOTE CONDENSING UNIT MUST BE GROUNDED.** Failure to properly ground the remote condensing unit could result in death or serious injury.

NOTICE

- Follow the water supply, drain connection, and maintenance instructions carefully to reduce the risk of costly water damage.
- In areas where water damage is a concern, install in a contained area with a floor drain.
- Install the icemaker in a location that stays above freezing. Normal operating ambient temperature must be within 45°F to 100°F (7°C to 38°C).
- Do not leave the icemaker on during extended periods of non-use, extended absences, or in sub-freezing temperatures. To properly prepare the icemaker for these occasions, follow the instructions in "IV. Preparing the Icemaker for Periods of Non-Use."
- Do not place objects on top of the appliance.
- The dispenser unit/ice storage bin is for ice use only. Do not store anything else in the dispenser unit/ice storage bin.

I. Specifications

A. Electrical and Refrigerant Data

The rating label (KMS) and nameplate (KMS and SRK) provide electrical and refrigerant data. The rating label can be seen by removing the front panel. The nameplate is located on the rear panel of the icemaker and on the side panel of the remote condensing unit. For certification marks, see the nameplate.

We reserve the right to make changes in specifications and design without prior notice.

1. KMS-1122MLH

Model Number	KMS-1122MLH
AC Supply Voltage	115-120/60/1
Pump	120V 0.5FLA 23W
Other	115V 0.8A
Design Pressure	HI-467PSI LO-230PSI
Total Refrigerant Charge	404A Total Refrigerant Charge with Hoshizaki Remote Condensing Unit SRK-12H/3: 16 LB. 5 OZ.

2. SRK-12H/3

Model Number	SRK-12H	SRK-12H3
AC Supply Voltage	208-230/60/1 (3 wire with neutral)	208-230/60/3
Compressor	230V 8.2RLA 56LRA	230V 7.5RLA 51.0LRA
Fan	115V 2.6FLA (total) 126W	115V 2.6FLA (total) 126W
Other	115V 0.4A	115V 0.4A
Maximum Fuse Size	20 AMPS	20 AMPS
Max. HACR Breaker (USA Only)	20 AMPS	20 AMPS
Max. Circ. Breaker (Canada Only)	20 AMPS	20 AMPS
Minimum Circuit Ampacity	20 AMPS	20 AMPS
Design Pressure	HI-467PSI LO-230PSI	HI-467PSI LO-230PSI
Refrigerant	404A Total Refrigerant Charge with Hoshizaki Icemaker KMS-1122MLH: 16 LB. 5 OZ.	404A Total Refrigerant Charge with Hoshizaki Icemaker KMS-1122MLH: 16 LB. 5 OZ.

B. Dimensions/Connections

1. KMS-1122MLH

Units: mm [in.]

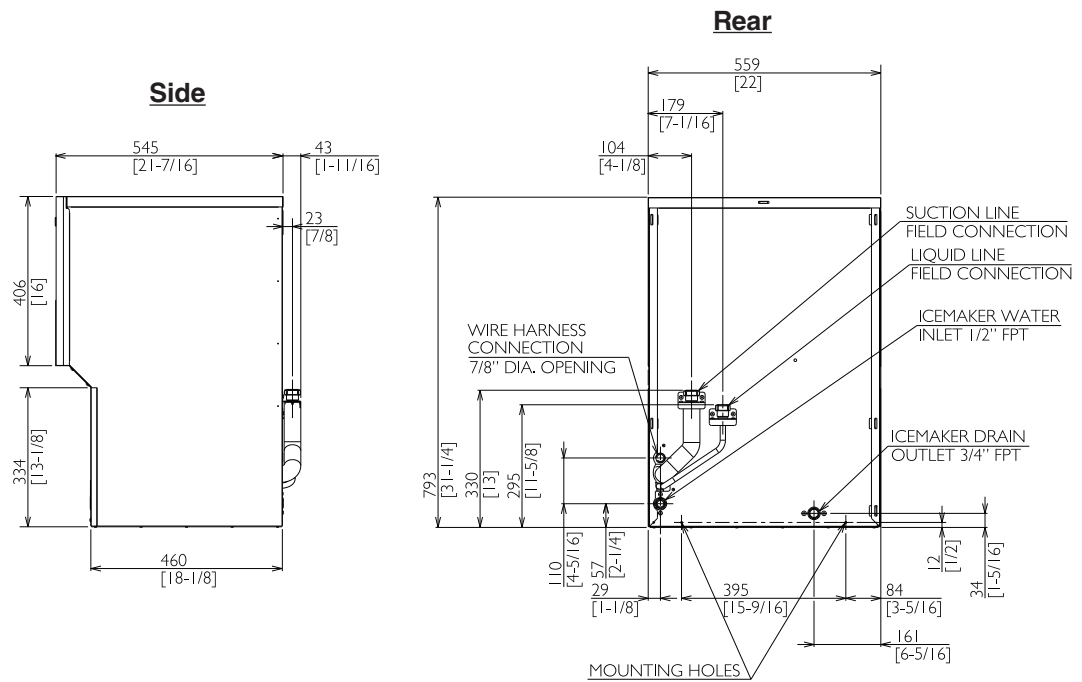

NOTICE

- Allow 15" (38 cm) clearance on left side for removal of spray tube and cube guide. There is no minimum clearance required for proper operation.
- The storage bin opening must match the bottom opening as in the illustration.

Bottom

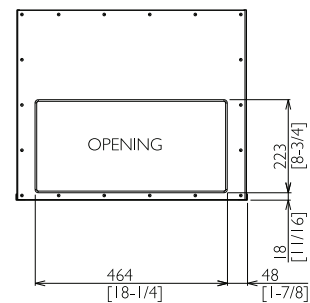

2. SRK-12H/3

Units: mm [in.]

Top

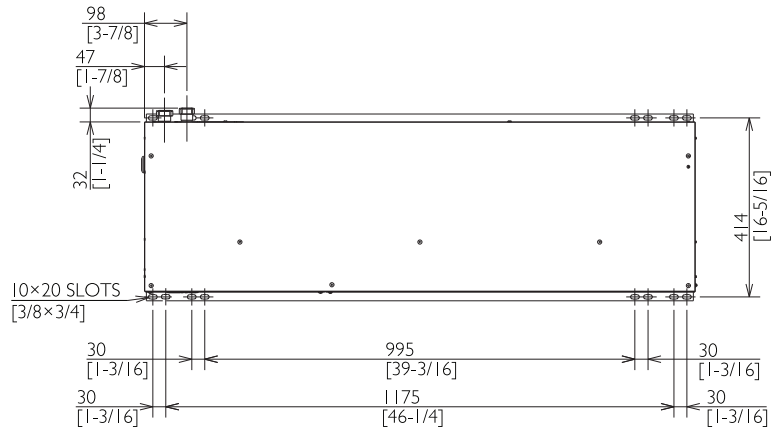

Side

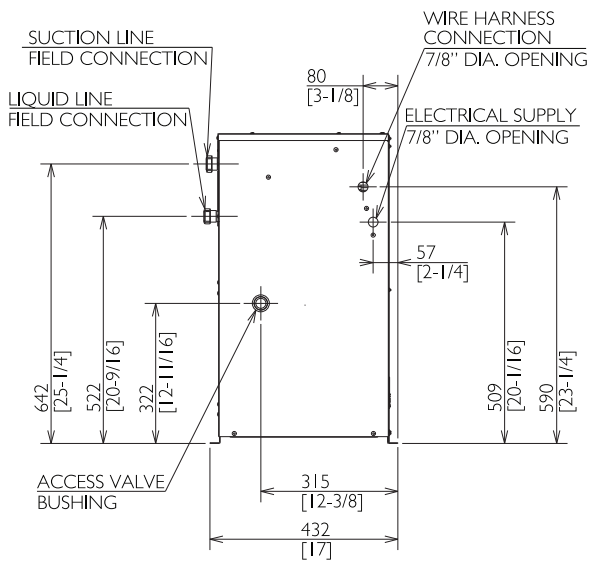

Front

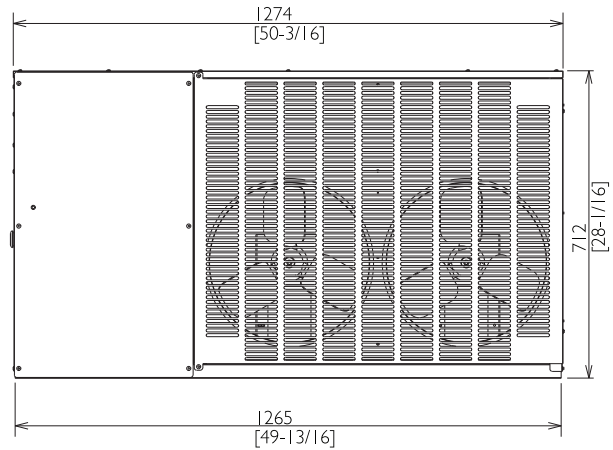

Note: Legs are included with remote condensing unit. Leg height is 380 mm (14.96 in.).

NOTICE

Allow 24" (61 cm) clearance at front and rear for proper air circulation and ease of maintenance and/or service should they be required.

	Heat of Rejection
	AT 90°F (32°C) WT 70°F (21°C)
Model	
KMS-1122MLH with SRK-12H	21,300 BTU/hr
KMS-1122MLH with SRK-12H3	21,000 BTU/hr

II. Installation and Operating Instructions

⚠ WARNING

- The icemaker and remote condensing unit must be installed in accordance with applicable national, state, and local codes and regulations.
- Failure to install, operate, and maintain the appliance in accordance with this manual will adversely affect safety, performance, component life, and warranty coverage and may result in costly water damage.
- **CHOKING HAZARD:** Ensure all components, fasteners, and thumbscrews are securely in place after installation. Make sure that none have fallen into the dispenser unit/ice storage bin.

A. Location

1. Icemaker

NOTICE

- This icemaker is not intended for outdoor use. Normal operating ambient temperature must be within 45°F to 100°F (7°C to 38°C); Normal operating water temperature must be within 45°F to 90°F (7°C to 32°C). Operation of the icemaker, for extended periods, outside of these normal temperature ranges may affect icemaker performance.
- This icemaker will not work at sub-freezing temperatures. To prevent damage to the water supply line, drain the icemaker if the air temperature is going to go below 32°F (0°C). See "IV. Preparing the Icemaker for Periods of Non-Use."

- The icemaker should not be located next to ovens, grills, or other high heat producing equipment.
- Allow 15" (38 cm) clearance on left side for removal of spray tube and cube guide. There is no minimum clearance required for proper operation.
- The location must provide a firm and level foundation for the equipment.

2. Remote Condensing Unit

NOTICE

- The remote condensing unit is intended for outdoor use. Normal operating ambient temperature must be within -20°F to 122°F (-29°C to 50°C). Operation of the remote condensing unit, for extended periods, outside of this normal temperature range may affect performance.
- The maximum line set length is 66' (20 m). No refrigerant charge adjustment is necessary.
- The maximum vertical distance between the remote condensing unit and icemaker is 33' (10 m) above or 10' (3 m) below the icemaker. These distances are measured fitting to fitting. See Fig. 1.
- If the vertical distance between the remote condensing unit and the icemaker is greater than 20' (6 m) (not to exceed 33' (10 m)), an "S" oil-trap (5/8" OD copper tubing) must be installed in the suction line. The "S" oil-trap must be located halfway between the icemaker and remote condensing unit. This ensures sufficient oil return to the compressor.

The remote condensing unit must be positioned in a permanent site under the following guidelines:

- A firm and flat site.
- A dry and well ventilated area with 24" (61 cm) clearance in both front and rear for proper air circulation and ease of maintenance and/or service should they be required. See Fig. 2.

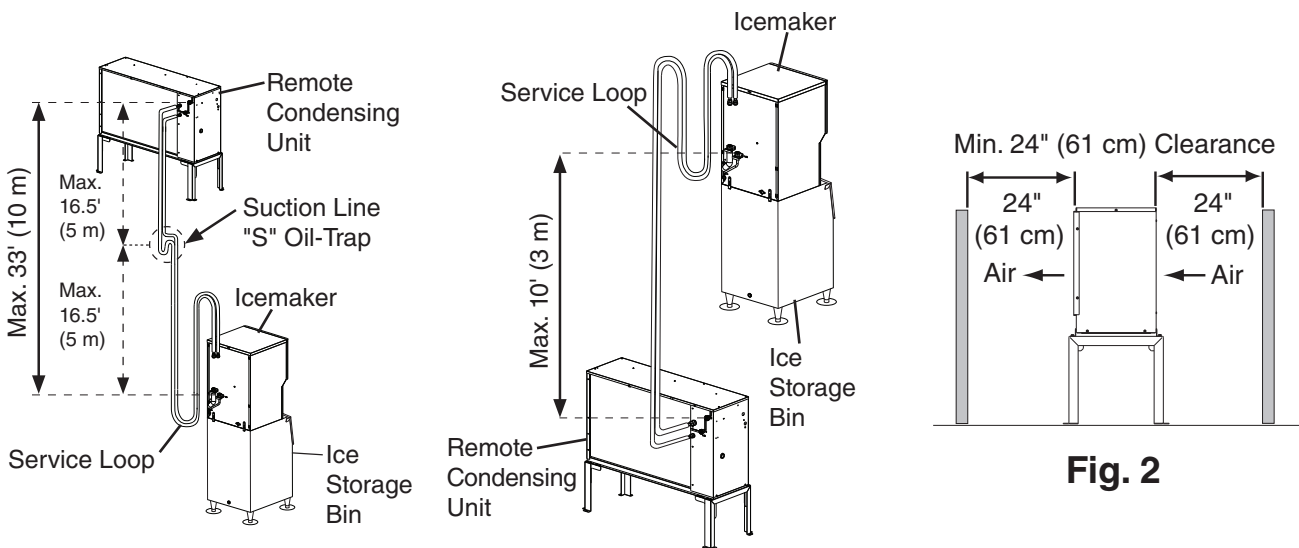

B. Checks Before Installation

- Visually inspect the exterior of the shipping containers and immediately report any damage to the carrier. Upon opening the containers, any concealed damage should also be immediately reported to the carrier.
- Remove the shipping carton, tape, and packing material. If any are left in the icemaker or remote condensing unit, they will not work properly.

1. Icemaker

- Remove the panels to prevent damage when installing the icemaker. See "II.C. How to Remove Panels."
- Remove the package containing the accessories.
- Remove the protective plastic film from the panels. If the icemaker is exposed to the sun or to heat, remove the film after the icemaker cools.
- Check that the refrigerant lines do not rub or touch lines or other surfaces.
- This icemaker can be installed on a dispenser unit or ice storage bin 22" wide or wider. For options, contact your local Hoshizaki distributor.
- **NOTICE! This icemaker is designed for connection to Hoshizaki Remote Condensing Unit Model SRK-12H or SRK-12H3 only! Connection to another remote condensing unit will void the warranty.**

2. Remote Condensing Unit

- See the nameplate on the remote condensing unit. Check that your voltage supplied corresponds with the voltage specified on the nameplate.
- Remove the panels to prevent damage when installing the remote condensing unit. See "II.C. How to Remove Panels."
- Remove the package containing the accessories.
- Check that the refrigerant lines do not rub or touch lines or other surfaces, and that the fan blades turn freely.
- Check that the compressor is snug on all mounting pads.

C. How to Remove Panels

1. Icemaker

- Front Panel: Loosen the screw. Lift up and towards you.
- Apron Panel: Loosen the screws. Lift off.
- Top Panel: Lift off.
- Left and Right Side Panels: Remove the screws. Push rearward slightly and lift off.
- Side Insulation Panel: Lift up slightly and pull towards you.
- Top Insulation Panel: Lift off.

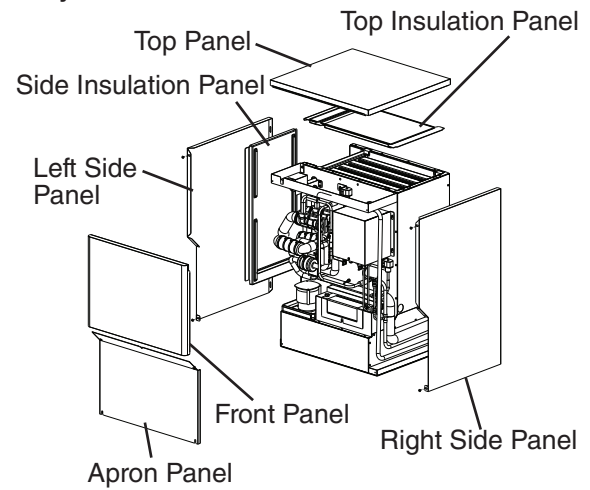

Icemaker

Fig. 3

2. Remote Condensing Unit

- Top Panel: Remove the screws and lift off.
- Front Panel: Remove the screws and lift off.
- Left Side/Rear Panel: Remove the screws and lift off.
- Louver Panel: Remove the screws and lift off.
- Right Side Panel: Remove the screws and lift off.

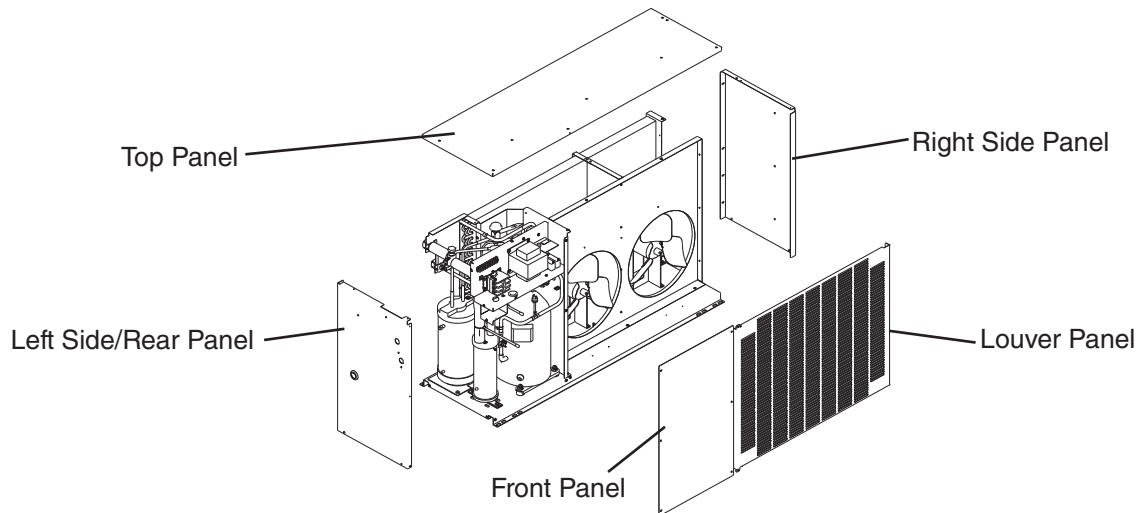

Remote Condensing Unit

Fig. 4

D. Setup

1. Dispenser Unit/Ice Storage Bin and Icemaker Setup

⚠ WARNING

The installer must ensure the dispenser unit/ice storage bin is compatible with the icemaker, and the dispenser unit/ice storage bin and icemaker are properly attached and secured.

NOTICE

- Do not connect the icemaker to an external power source. Icemaker power supply and ground connection are supplied from the remote condensing unit via the wire bundle provided with the remote condensing unit. For details, see "II.F. Electrical Connection."
- Before operating the icemaker, the bin control must be installed correctly. Failure to properly install the bin control could result in ice backup and unit damage.

- 1) If mounting the icemaker on top of a dispenser unit, follow the dispenser unit's setup procedure. If mounting the icemaker on top of an ice storage bin, unpack the ice storage bin and attach the 4 adjustable legs provided (bin accessory) to the bottom of the ice storage bin.
- 2) Position the dispenser unit/ice storage bin in its permanent location.
- 3) If required, install an adapter kit or top kit. Contact your local Hoshizaki distributor for recommendations.
- 4) Level the dispenser unit/ice storage bin in both the left-to-right and front-to-rear directions. If using an ice storage bin, adjust the ice storage bin legs to level.
- 5) Place the icemaker on top of the dispenser unit/ice storage bin.
- 6a) **Dispenser Unit:** Follow the dispenser unit's instructions for securing the icemaker to the dispenser unit. If no instructions are available, secure the icemaker to the dispenser unit using the mounting brackets provided. If the installation requires the dispenser unit to extend 2 inches beyond the back of the icemaker, use the offset mounting brackets. See Fig. 5a. If the icemaker is flush with the back of the dispenser, use the standard mounting brackets and rotate them so that they fit flush to the icemaker and dispenser unit. Secure the mounting brackets to the icemaker with the machine bolts provided. Secure the mounting brackets to the dispenser unit with the self-tapping bolts provided. **NOTICE! Use care to avoid damage to dispenser unit components when attaching the mounting brackets.**
- 6b) **Ice Storage Bin:** Secure the icemaker to the ice storage bin using the standard mounting brackets and the machine bolts provided. See Fig. 5b.

Dispenser Unit Application

2" (51 mm) Offset Mount

Flush Mount

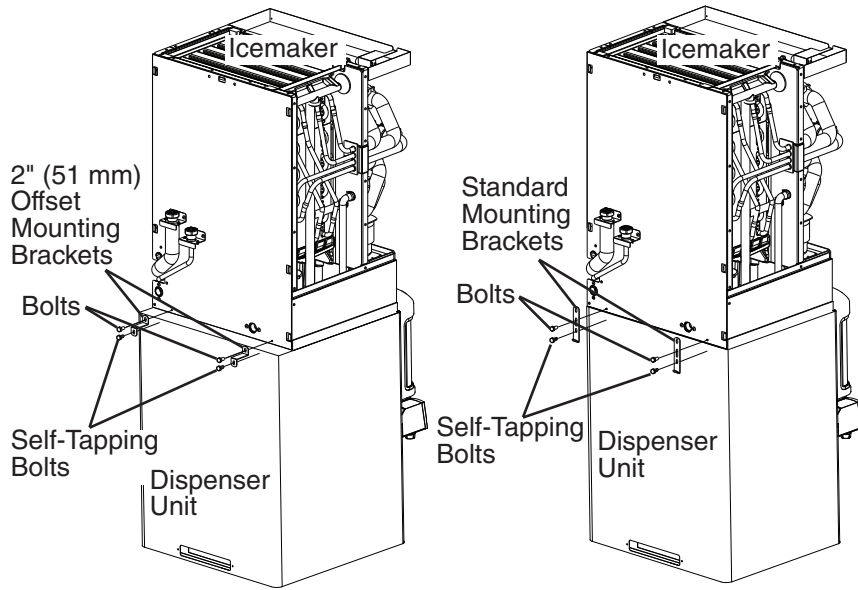

Fig. 5a

Ice Storage Bin Application

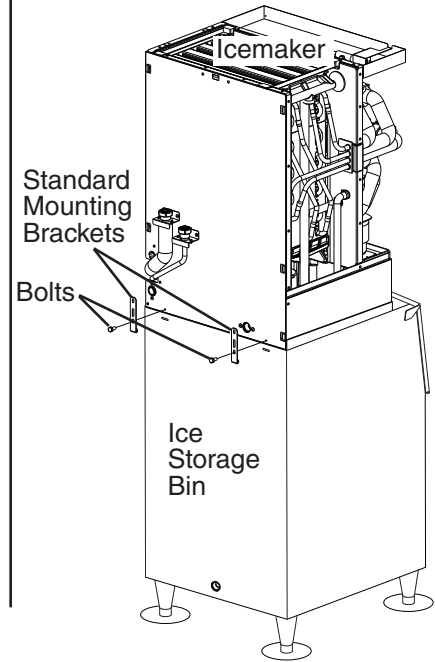

Fig. 5b

2. Bin Control

NOTICE

Before operating the icemaker, the bin control assembly must be installed correctly. Failure to properly install the bin control assembly could result in ice backup and unit damage.

- 1) Remove the bin control insulation and bin control cover. See Fig. 6.
- 2) Remove the bin control bracket, bin control bulb holder, two 4x6 screws, two lock washers, two flat washers, 3 wire ties, and two 4x8 screws from the accessory bag.
- 3) Secure the bin control bracket to the bin control cover using the two 4x6 screws, two lock washers, and two flat washers.
- 4) The bin control bulb is located under the control box. Route the bin control bulb and protective hose through the hole in the bin control bracket as illustrated. **NOTICE! Be careful not to kink the bin control capillary tube.**
- 5) Carefully install the bin control bulb into the bin control bulb holder, then secure the bin control bulb holder to the bin control bracket using the two 4x8 screws. **NOTICE! Place the bin control capillary tube and protective hose outside the flange on the bin control bracket and secure with 3 wire ties. This helps protect the capillary tube.**
- 6) Lower the bin control assembly into position, then secure the bin control cover with 2 thumbscrews.
- 7) Replace the bin control insulation in its proper position.

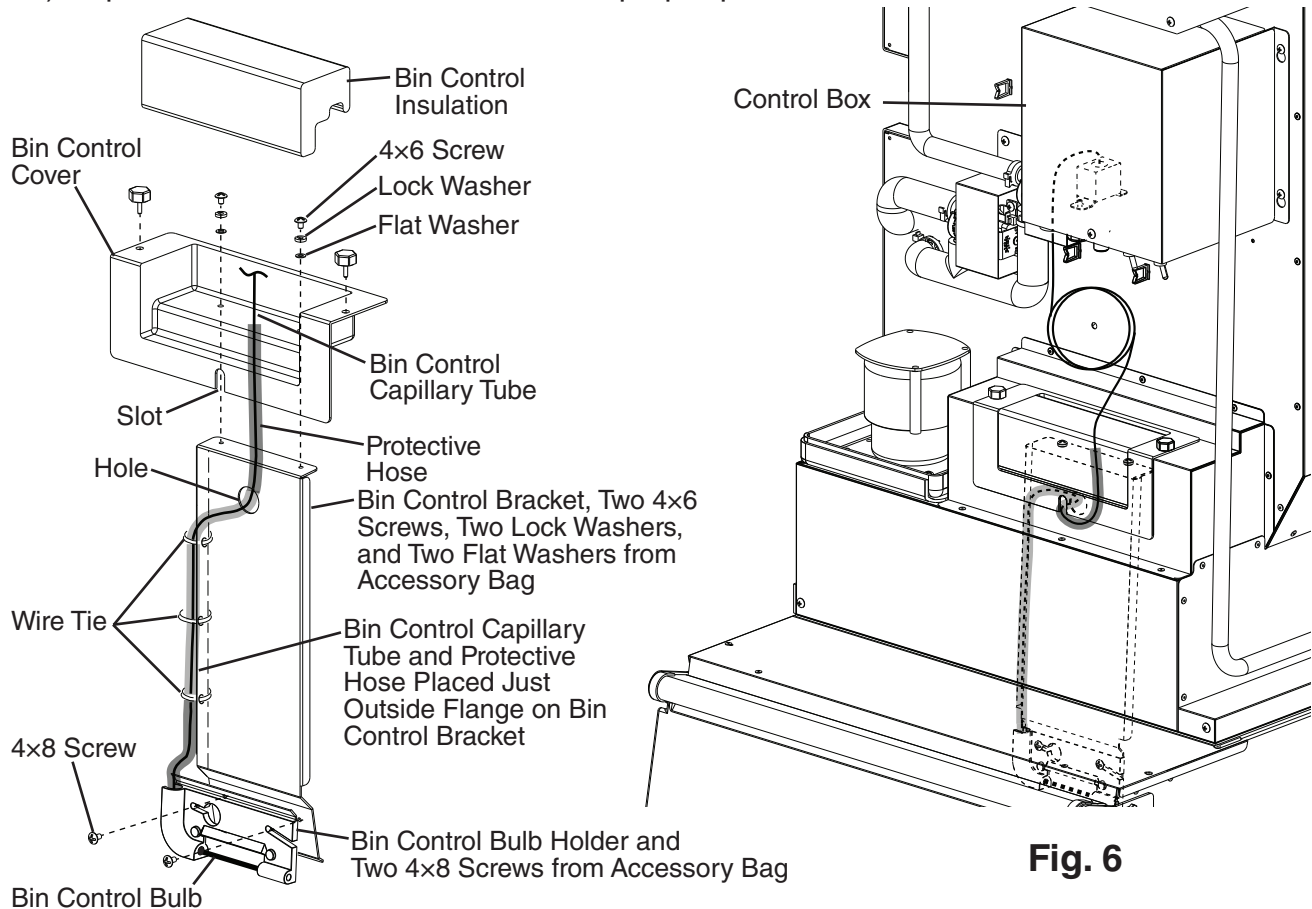

Fig. 6

E. Installation of the Remote Condensing Unit

⚠ WARNING

- Installation must be performed by properly trained and EPA-certified service personnel.
- Power supply and ground wire to the icemaker are supplied from the remote condensing unit. For details, see "II.F. Electrical Connection."

1. Setup

- 1) Secure the legs to the remote condensing unit with the 16 bolts and nuts provided. See Fig. 7.
- 2) The legs have 8 mounting holes. Secure the legs with 8 bolts (not included).

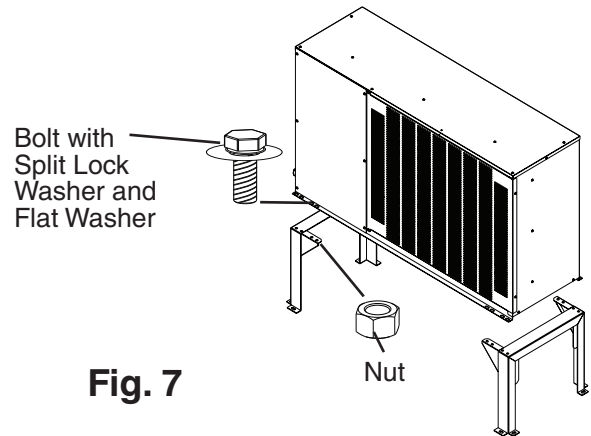

Fig. 7

2. Line Set

NOTICE

- The icemaker, line set, and remote condensing unit must contain the same type of refrigerant. Mixing of refrigerants will result in improper operation and possible damage to the refrigeration system.
- The maximum line set length is 66' (20 m). No refrigerant charge adjustment is necessary.
- The maximum vertical distance between the remote condensing unit and icemaker is 33' (10 m) above or 10' (3 m) below the icemaker. These distances are measured fitting to fitting. See Fig. 8.
- If the vertical distance between the remote condensing unit and the icemaker is greater than 20' (6 m) (not to exceed 33' (10 m)), an "S" oil-trap (5/8" OD copper tubing) must be installed in the suction line. The "S" oil-trap must be located halfway between the icemaker and remote condensing unit. This ensures sufficient oil return to the compressor.

Line Set Size for SRK-12H/3 Remote Condensing Unit

Hoshizaki Icemaker	Liquid Line	Suction Line	Factory Line Set Lengths	Maximum Line Set Length
KMS-1122MLH	1/2" OD	5/8" OD	20' (6 m), 35' (11 m), and 55' (17 m)	66' (20 m)

Precharged factory line sets, available as optional equipment from Hoshizaki America, are recommended. For details see "II.E.2.a) Factory Line Set Installation." Field fabricated line sets are allowed. For details, see "II.E.2.b) Field Fabricated Line Set Installation."

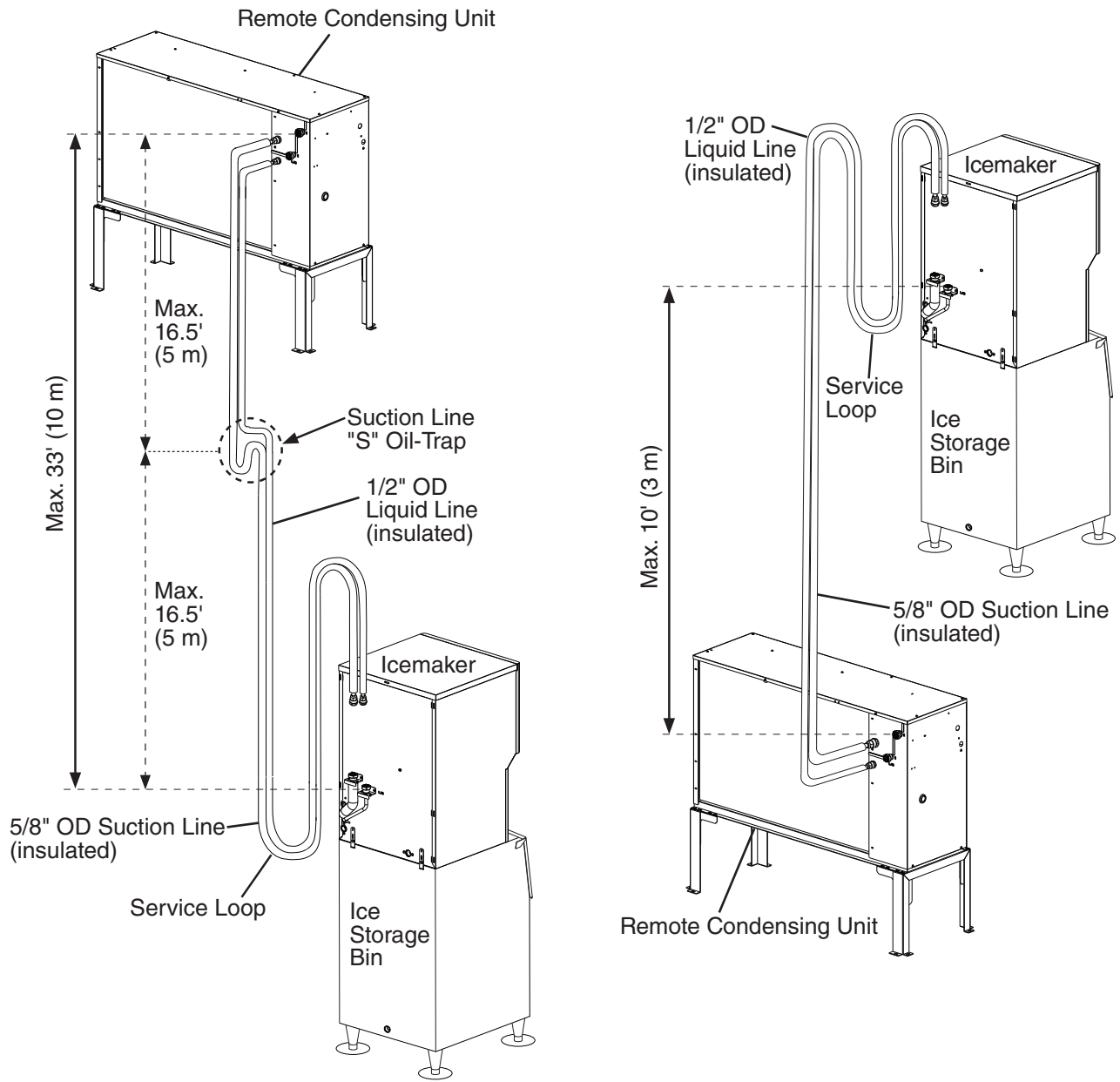

Fig. 8

a) Factory Line Set Installation

- 1) Route the factory line set (5/8" OD suction line and 1/2" OD liquid line) from the remote condensing unit to the icemaker. Leave a service loop behind the icemaker to allow the icemaker to be pulled out for service. See Fig. 8. Factory fabricated line sets are precharged and do not need to be evacuated. If the line set is too long or too short, see "II.E.2.a)(1) Factory Line Set Modification."

NOTICE
<ul style="list-style-type: none">• Ensure that there are no traps and no kinks in the line set. The service loop is not considered an oil trap.• Do not coil extra line set.

- 2) Connect the refrigerant lines to the appropriate male fittings on the icemaker first and then at the remote condensing unit. Make a proper connection as follows:
 - a. Remove the protective covers from the male fitting and female coupling.
 - b. Apply Polyol Ester (POE) refrigerant oil or Parker Super O Lube to the entire male fitting, including O-ring, diaphragm, and threads before making the connection. See Fig. 9. **NOTICE! Do not use thread sealant on the fittings. Use POE refrigerant oil or Parker Super O Lube only.**
 - c. Make sure the male fitting and female coupling are properly aligned, then start the connection by hand to ensure that it is not cross threaded.
 - d. Tighten the connection with a wrench until it is tight. At this point, the nut has covered most of the threads on the male fitting.
 - e. Mark a reference line on the female coupling and the remote condensing unit or icemaker panel. Using a backup wrench on the back of the female coupling, tighten the six-sided nut of the female coupling an additional 1/6 turn. See Fig. 10.

(1) Factory Line Set Modification

- 1) Recover the line set charge through the Schrader access ports on the Parker quick connect couplings and store it in an approved container. Do not discharge the refrigerant into the atmosphere. Remove the extra line set length or add extra tubing. When adding extra tubing, insulate the additional copper tubes separately.
- 2) Use an electronic leak detector or soap bubbles to check for leaks. Add a trace of refrigerant to the lines through the Schrader access ports on the Parker quick connect couplings (if using an electronic leak detector), and then raise the pressure using nitrogen gas (140 PSIG). **WARNING! Do not use R-404A as a mixture with pressurized air for leak testing.**
- 3) Evacuate through the Schrader access ports on the Parker quick connect couplings and charge with R-404A refrigerant vapor to a pressure of 15 to 30 PSIG. Go to step 2 in "II.E.2.a) Factory Line Set Installation."

b) Field Fabricated Line Set Installation

- 1) Route a 5/8" OD copper tube suction line and a 1/2" OD copper tube liquid line from the remote condensing unit to the icemaker. Leave a service loop behind the icemaker to allow the icemaker to be pulled out for service. See Fig. 14.

NOTICE
<ul style="list-style-type: none">• Ensure that there are no traps and no kinks in the line set. The service loop is not considered an oil trap.• Do not coil extra line set. Fabricate the line set to the proper length.

- Ensure that there are no traps and no kinks in the line set. The service loop is not considered an oil trap.
 - Do not coil extra line set. Fabricate the line set to the proper length.
- 2) Insulate the two copper tubes separately.
 - 3) Install Parker quick connect couplings on each end. OS-Quick, a universal quick connect coupling kit available as optional equipment from Hoshizaki America, is recommended. **NOTICE! Before brazing, remove the Schrader valve core from the access port. When brazing, protect the coupling by using a wet cloth to prevent the coupling from overheating. Do not use silver alloy or copper alloy containing arsenic.**
 - 4) Allow the coupling to cool, then replace the Schrader valve core.
 - 5) Use an electronic leak detector or soap bubbles to check for leaks. Add a trace of refrigerant to the to the lines through the Schrader access ports on the Parker quick connect couplings (if using an electronic leak detector), and then raise the pressure using nitrogen gas (140 PSIG). **WARNING! Do not use R-404A as a mixture with pressurized air for leak testing.**
 - 6) Evacuate through the Schrader access ports on the Parker quick connect couplings and charge with R-404A refrigerant vapor to a pressure of 15 to 30 PSIG.
 - 7) Connect the refrigerant lines to the appropriate male fittings on the icemaker first and then at the remote condensing unit. Make a proper connection as follows:
 - a. Remove the protective covers from the male fitting and female coupling.
 - b. Apply Polyol Ester (POE) refrigerant oil or Parker Super O Lube to the entire male fitting, including O-ring, diaphragm, and threads, before making the connection. See Fig. 9. **NOTICE! Do not use thread sealant on the fittings. Use POE refrigerant oil or Parker Super O Lube only.**
 - c. Make sure the male fitting and female coupling are properly aligned, then start the connection by hand to ensure that it is not cross threaded.
 - d. Tighten the connection with a wrench until it is tight. At this point, the nut has covered most of the threads on the male fitting.
 - e. Mark a reference line on the female coupling and the remote condensing unit or icemaker panel. Using a backup wrench on the back of the female coupling, tighten the six-sided nut of the female coupling an additional 1/6 turn. See Fig. 10.

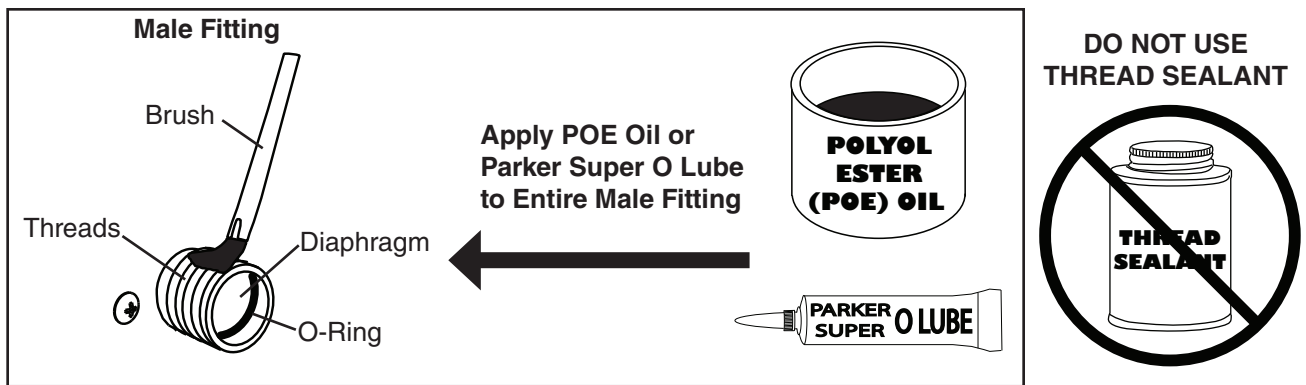

Fig. 9



Fig. 10

F. Electrical Connection

⚠ WARNING

Icemaker

- Do not connect the icemaker to an external power source. Icemaker power supply and ground connection are supplied from the remote condensing unit via the wire bundle provided with the remote condensing unit.
- Wire bundle routing (conduit) and disconnect (if required) must meet national, state, and local electrical code requirements. If fabricating a wire bundle, use wire of an appropriate gage and outdoor rating. Failure to meet these code requirements could result in death, electric shock, serious injury, fire, or damage.
- **THE ICEMAKER MUST BE GROUNDED.** Failure to properly ground the icemaker could result in death or serious injury.
- To reduce the risk of electric shock, do not connect the remote condensing unit power supply until after all wire bundle connections have been made.

Remote Condensing Unit

- Remote condensing unit electrical connection must be hard-wired and must meet national, state, and local electrical code requirements. Failure to meet these code requirements could result in death, electric shock, serious injury, fire, or damage.
- The remote condensing unit requires an independent power supply of proper capacity. See the nameplate for electrical specifications. Failure to use an independent power supply of proper capacity can result in a tripped breaker, blown fuse, damage to existing wiring, or component failure. This could lead to heat generation or fire.
- **THE REMOTE CONDENSING UNIT MUST BE GROUNDED.** Failure to properly ground the remote condensing unit could result in death or serious injury.
- Remote condensing unit electrical connection must be made in accordance with the instructions on the "WARNING" tag provided with the pig tail leads in the remote condensing unit's power supply junction box. See Fig. 11.

NOTICE

The remote condensing unit must have power for a minimum of 4 hours prior to startup to prevent compressor damage.

- Usually an electrical permit and services of a licensed electrician are required.
- The maximum allowable voltage variation is ± 10 percent of the nameplate rating.
- The openings for the power supply and wire bundle connections are 7/8" DIA to fit a 1/2" trade size conduit.

- 1) Route the wire bundle between the icemaker and remote condensing unit. Use the wire bundle supplied with the remote condensing unit, or fabricate a wire bundle using wire of an appropriate gage and outdoor rating. Use the wiring label or Fig. 12 as a reference.
- 2a) Icemaker: Connect the wire bundle ground wire to the icemaker ground screw, then connect the rest of the wire bundle wires to the icemaker terminal block.
WARNING! Do not connect the wire bundle ground wire to the icemaker terminal block.
- 2b) Remote Condensing Unit: Connect the wire bundle ground wire to the remote condensing unit ground screw (located next to the terminal block).
WARNING! Do not connect the wire bundle ground wire to the remote condensing unit terminal block.
- 3) Connect the power supply from the disconnect or electrical panel to the leads in the remote condensing unit's power supply junction box. This differs from KM style installations. Connect a ground wire to the ground screw. See Fig. 11.
 - On single phase models, the white lead must be connected to the neutral conductor of the power source. **NOTICE! Miswiring may result in severe damage to the icemaker.**
 - On three phase models, the transformer's voltage tap switch must be positioned to match incoming voltage at startup.
 - **NOTICE! On three phase models, connect the highest incoming voltage supply ("stinger leg") to the power wire dedicated to the compressor. See the wiring label on the remote condensing unit.**
- 4) Replace all removed parts and panels in their correct positions.
- 5) Turn on the power supply to the remote condensing unit. **NOTICE! The remote condensing unit must have power for a minimum of 4 hours prior to startup to prevent compressor damage.**

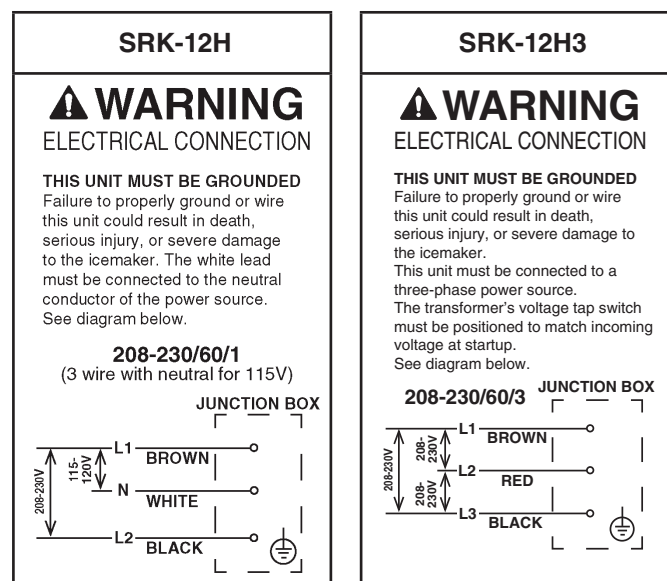
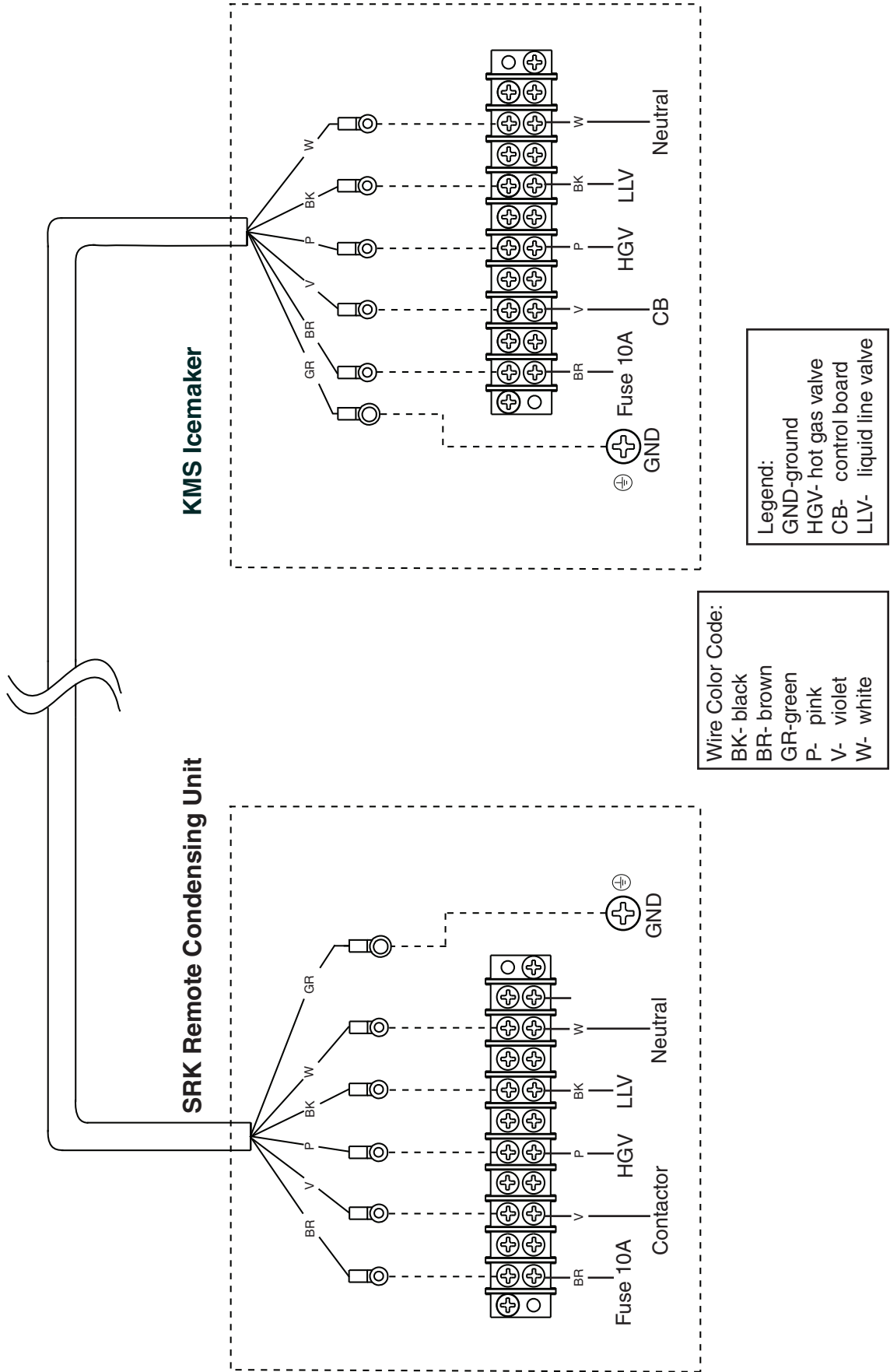

Fig. 11

Icemaker-Remote Condensing Unit Wire Bundle Connections

Fig. 12

Use wire bundle supplied with the Remote Condensing Unit or fabricate a wire bundle using wire of an appropriate gage and outdoor rating.



G. Water Supply and Drain Connections

See Fig. 13

⚠ WARNING

Water supply and drain connections must be installed in accordance with applicable national, state, and local regulations.

NOTICE

- Normal operating water temperature should be within 45°F to 90°F (7°C to 32°C). Operation of the icemaker, for extended periods, outside of this normal temperature range may affect performance.
- To prevent damage to equipment, do not operate the icemaker when the water supply is off, or if the pressure is below 10 PSIG. Do not run the icemaker until the proper water pressure is reached.

- A plumbing permit and services of a licensed plumber may be required in some areas.
- External filters, strainers, or softeners may be required depending on water quality. Contact your local Hoshizaki distributor for recommendations.
- Water supply pressure must be a minimum of 10 PSIG and a maximum of 113 PSIG. If the pressure exceeds 113 PSIG, the use of a pressure reducing valve is required.
- The icemaker drain line and dispenser unit/ice storage bin drain line must be run separately.
- Drain lines must have 1/4" fall per foot (2 cm per 1 m) on horizontal runs to get a good flow. A vented tee connection is also required for proper flow.
- Drain lines should not be piped directly to the sewer system. An air gap of a minimum of 2 vertical inches (5 cm) should be between the end of the drain pipes from the icemaker and dispenser unit/ice storage bin and the floor drain.

1. Icemaker

Icemaker Water Supply Inlet	Minimum Icemaker Water Supply Line Size	Icemaker Drain Outlet	Minimum Icemaker Drain Line Size
1/2" Female Pipe Thread (FPT)	3/8" Nominal ID Copper Water Tubing or Equivalent	3/4" Female Pipe Thread (FPT)	3/4" Nominal ID Hard Pipe or Equivalent

- An icemaker water supply line shut-off valve and drain valve must be installed.
- Be sure there is sufficient extra water supply line and drain line for the appliance to be pulled out for service.

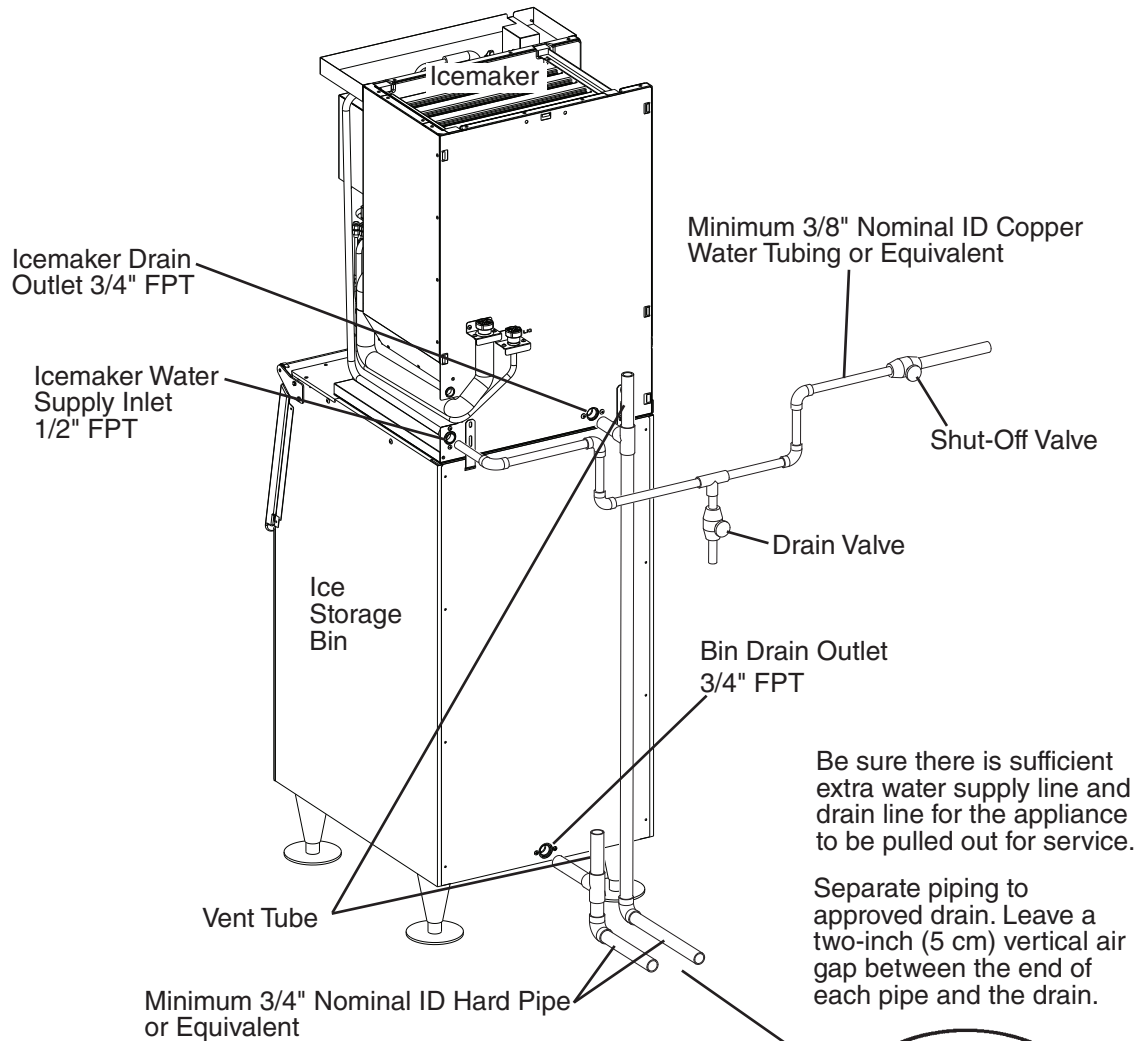

KMS-1122MLH

Fig. 13

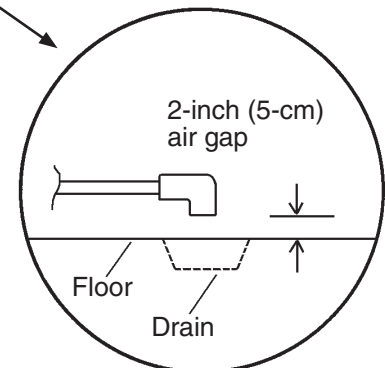

H. Final Checklist

WARNING

CHOKING HAZARD: Ensure all components, fasteners, and thumbscrews are securely in place after installation. Make sure that none have fallen into the dispenser unit/ice storage bin.

- 1) Is the icemaker level?
- 2) Is the icemaker in a site where the ambient temperature is within 45°F to 100°F (7°C to 38°C) and the water temperature within 45°F to 90°F (7°C to 32°C) all year around?
- 3) Is there at least 15" (38 cm) clearance on left side for removal of the spray tube and cube guide?
- 4) Is the remote condensing unit in a site where the ambient temperature is within -20°F to 122°F (-29°C to 50°C) all year around?
- 5) Is there at least 24" (61 cm) clearance around the remote condensing unit for proper air circulation and ease of maintenance and service?
- 6) Have the shipping carton, tape, and packing material been removed from the icemaker and remote condensing unit? Is the cube guide in its correct position?
- 7) Has the bin control assembly been properly installed?
- 8) Have all electrical and water connections been made? Do electrical and water connections meet all national, state, and local code and regulation requirements?
- 9) Has the power supply voltage been checked or tested against the nameplate rating? Has a proper ground been installed to the remote condensing unit and icemaker unit? On three phase models, has the transformer's voltage tap switch been positioned to match incoming voltage? For details, see "II.F. Electrical Connection."
- 10) Has the electrical power supply been on to the remote condensing unit for a minimum of 4 hours?
- 11) Are the water supply and drain lines sized as specified? Are the water supply line shut-off valve and drain valve installed? Has the water supply pressure been checked to ensure a minimum of 10 PSIG and a maximum of 113 PSIG?
- 12) Are the compressor hold-down bolts snug? Have the refrigerant lines been checked to make sure they do not rub or touch other lines or surfaces? Have the fan blades been checked to make sure they turn freely?
- 13) Is the line set free of leaks and kinks? If needed, has an "S" oil-trap been installed?
- 14) Are all components, fasteners, and thumbscrews securely in place?
- 15) Has the end user been given the instruction manual, and instructed on how to operate the icemaker and the importance of the recommended periodic maintenance?
- 16) Has the end user been given the name and telephone number of an authorized service agent?
- 17) Has the warranty card been filled out and forwarded to the factory for warranty registration?

I. Startup

⚠ WARNING

All parts are factory-adjusted. Improper adjustments may adversely affect safety, performance, component life, and warranty coverage.

NOTICE

- If the appliance is turned off, wait for at least 3 minutes before restarting the appliance to prevent damage to the compressor.
- To prevent damage to the water pump, do not leave the control switch in the "SERVICE" position when the water tank is empty.
- At startup, confirm that all internal and external connections are free of leaks.
- The remote condensing unit must have power for a minimum of 4 hours prior to startup to prevent compressor damage.

- 1) If removed, replace all panels except the front panel in their correct positions. If not already removed, remove the front panel.
- 2) Open the water supply line shut-off valve.
- 3) Move the control switch to the "ICE" position. See Fig. 14. Replace the front panel in its correct position.
- 4) Turn on the power supply, and allow the water tank to fill and the icemaker to operate for a total of 10 minutes.
- 5) Move the control switch to the "OFF" position, then turn off the power supply.
- 6) Remove the front, apron, top, left side, and side insulation panels.
- 7) Remove the drain plug. Allow the water tank to drain.

Fig. 14

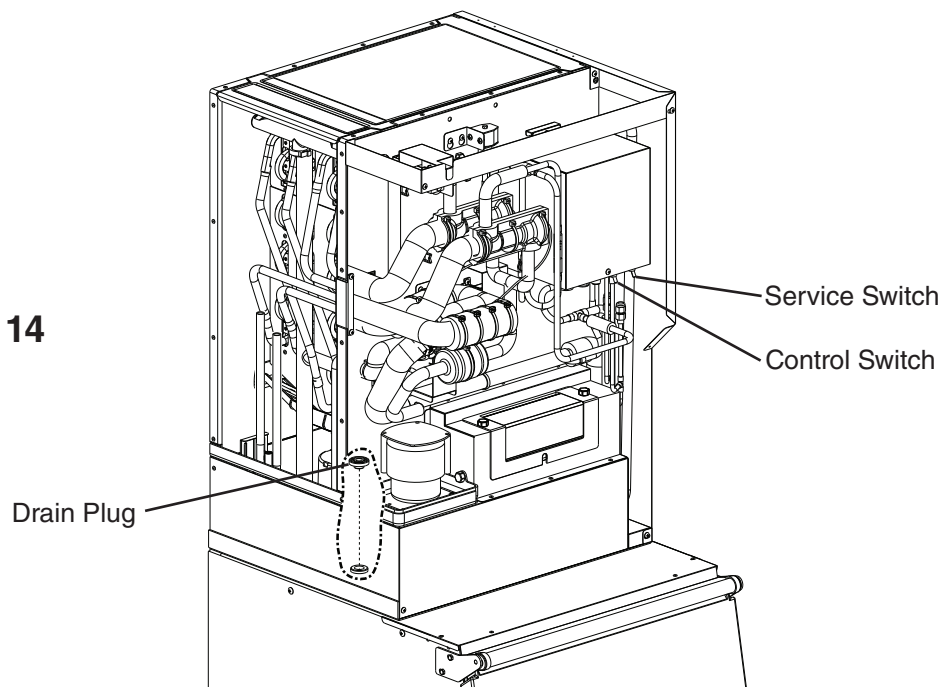

- 8) Replace the drain plug in its correct position. Be careful not to cross thread the drain plug.
- 9) Clean the dispenser unit/ice storage bin liner using a neutral cleaner. Rinse thoroughly after cleaning.
- 10) Move the control switch to the "ICE" position.
- 11) Replace the side insulation, left side, top, apron, and front panels in their correct positions.
- 12) Turn on the power supply to start the automatic icemaking process.
- 13) To confirm bin control operation, hold ice in contact with the bin control thermostat bulb. If the icemaker does not stop within 10 seconds, the bin control thermostat must be adjusted. Installations at higher altitude locations are more likely to require adjustment.

III. Maintenance

The icemaker must be maintained in accordance with the instruction manual and labels provided with the icemaker. Consult with your local Hoshizaki Certified Service Representative about maintenance service.

WARNING

- Only qualified service technicians should service the icemaker.
- To reduce the risk of electric shock, do not touch the control switch or service switch with damp hands.
- Move the control switch to the "OFF" position and turn off the power supply to the remote condensing unit before servicing. Place the icemaker disconnect (if applicable) in the off position. Lockout/Tagout to prevent the power supply from being turned back on inadvertently.
- **CHOKING HAZARD:** Ensure all components, fasteners, and thumbscrews are securely in place after any maintenance is done to the icemaker. Make sure that none have fallen into the dispenser unit/ice storage bin.

A. Maintenance Schedule

The maintenance schedule below is a guideline. More frequent maintenance may be required depending on water quality, the icemaker's environment, and local sanitation regulations.

Maintenance Schedule		
Frequency	Area	Task
Daily	Scoop	Clean the ice scoop using a neutral cleaner. Rinse thoroughly after cleaning.
Monthly	External Water Filters	Check for proper pressure and change if necessary.
	Icemaker Exterior	Wipe down with a clean, soft cloth. Use a damp cloth containing a neutral cleaner to wipe off oil or dirt build up. Clean any chlorine staining (rust colored spots) using a non-abrasive cleanser.
Yearly	Icemaker and Dispenser Unit/Ice Storage Bin Liner	Clean and sanitize per the cleaning and sanitizing instructions provided in this manual. See "III.B. Cleaning and Sanitizing Instructions."
	Water Supply Inlet	Close the icemaker water supply line shut-off valve and drain the water system. Clean the water supply inlet screen.
	Condenser	Inspect. Clean if necessary by using a brush or vacuum cleaner. More frequent cleaning may be required depending on location.
	Water Hoses	Inspect the water hoses and clean/replace if necessary.

B. Cleaning and Sanitizing Instructions

The icemaker must be cleaned and sanitized at least once a year. More frequent cleaning and sanitizing may be required in some water conditions.

⚠ WARNING

- To prevent injury to individuals and damage to the icemaker, do not use ammonia type cleaners.
- Carefully follow any instructions provided with the bottles of cleaning and sanitizing solution.
- Always wear liquid-proof gloves and goggles to prevent the cleaning and sanitizing solutions from coming into contact with skin or eyes.

NOTICE

To prevent damage to the water pump, do not leave the control switch in the "SERVICE" position for extended periods when the water tank is empty.

1. Cleaning Procedure

- 1) Dilute 27 fl. oz. (800 ml) of Hoshizaki "Scale Away" with 5 gal. (19 l) of warm water.
- 2) Remove all ice from the evaporator and the dispenser unit/ice storage bin.
Note: To remove cubes on the evaporator, turn off the power supply and turn it back on after 3 minutes. The harvest cycle starts and the cubes will be removed from the evaporator.
- 3) Turn off the power supply.
- 4) Remove the front panel, then move the control switch to the "SERVICE" position. Move the service switch to the "DRAIN" position.
- 5) Replace the front panel in its correct position, then turn on the power supply for 2 minutes to drain the water tank.
- 6) Turn off the power supply.
- 7) Remove the front, apron, top, left side, and side insulation panels. See Fig. 15.

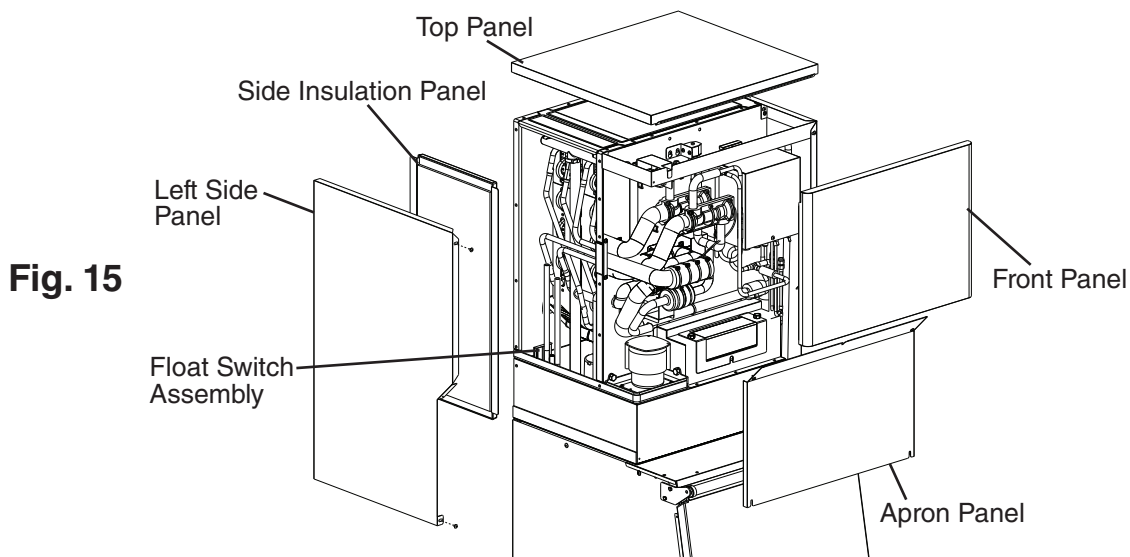

Fig. 15

- 8) In bad or severe water conditions, clean the float switch as described below. Otherwise, continue to step 9.
 - a. Remove the float switch assembly.
 - b. Remove the retainer rod from the bottom of the float switch housing, then remove the float. Be careful not to bend the retainer rod excessively when removing it.
 - c. Wipe down the float switch assembly's housing, shaft, float, and retainer rod with cleaning solution. Rinse the parts thoroughly with clean water.
 - d. Reassemble the float switch assembly and replace it in its correct position.
- 9) Pour the cleaning solution into the water tank.
- 10) Move the service switch to the "WASH" position.
- 11) Replace the side insulation, left side, top, apron, and front panels in their correct positions.
- 12) Turn on the power supply to start the cleaning process.
- 13) Turn off the power supply after 30 minutes. Remove the front panel.
- 14) Move the service switch to the "DRAIN" position.
- 15) Replace the front panel in its correct position, then turn on the power supply for 2 minutes to drain the water tank.
- 16) Turn off the power supply, then remove the front panel.
- 17) Move the control switch to the "ICE" position.
- 18) Replace the front panel in its correct position, then turn on the power supply for 3 minutes to fill the water tank.
- 19) Turn off the power supply, then remove the front panel.
- 20) Move the control switch to the "SERVICE" position, then move the service switch to the "WASH" position.
- 21) Replace the front panel in its correct position, then turn on the power supply for 5 minutes to rinse off the cleaning solution.
- 22) Turn off the power supply, then remove the front panel.
- 23) Move the service switch to the "DRAIN" position.
- 24) Replace the front panel in its correct position, then turn on the power supply for 2 minutes to drain the water tank.
- 25) Turn off the power supply, then remove the front panel.
- 26) Repeat steps 17 through 25 three more times to rinse thoroughly.

Note: If you do not sanitize the icemaker, go to step 13 in "III.B.2. Sanitizing Procedure."

2. Sanitizing Procedure - Following Cleaning Procedure

- 1) Dilute 2.5 fl. oz. (74 ml or 5 tbs) of a 5.25% sodium hypochlorite solution (chlorine bleach) with 5 gal. (19 l) of warm water.
- 2) Remove the front, apron, top, left side, and side insulation panels if they are in their normal positions.
- 3) Pour the sanitizing solution into the water tank.

- 4) Move the service switch to the "WASH" position.
- 5) Replace the side insulation, left side, top, apron, and front panels in their correct positions.
- 6) Turn on the power supply to start the sanitizing process.
- 7) Turn off the power supply after 15 minutes. Remove the front panel.
- 8) Move the service switch to the "DRAIN" position.
- 9) Replace the front panel in its correct position, then turn on the power supply for 2 minutes to drain the water tank.
- 10) Turn off the power supply, then remove the front panel.
- 11) Repeat steps 17 through 25 in "III.B.1. Cleaning Procedure" two times to rinse thoroughly.
- 12) Repeat steps 1 through 11 two more times.
- 13) Move the control switch to the "ICE" position.
- 14) Replace the front panel in its correct position.
- 15) Clean the dispenser unit/ice storage bin liner using a neutral cleaner. Rinse thoroughly after cleaning.
- 16) Turn on the power supply to start the automatic icemaking process.

IV. Preparing the Icemaker for Periods of Non-Use

NOTICE
<ul style="list-style-type: none">• When storing the icemaker for an extended time or in sub-freezing temperatures, follow the instructions below to prevent damage.• To prevent damage to the water pump, do not leave the control switch in the "SERVICE" position for extended periods when the water tank is empty.

When the icemaker is not used for two or three days under normal conditions, it is sufficient to move the control switch to the "OFF" position. When storing the icemaker for an extended time or in sub-freezing temperatures, follow the instructions below.

1. Remove the water from the icemaker water line:

- 1) Turn off the power supply, then remove the front panel.
- 2) Close the icemaker water supply line shut-off valve and open the icemaker water supply line drain valve.
- 3) Allow the line to drain by gravity.
- 4) Attach a compressed air or carbon dioxide supply to the icemaker water supply line drain valve.
- 5) Make sure at least 3 minutes have elapsed since you turned off the power supply. Make sure the control switch is in the "ICE" position. Replace the front panel in its correct position, then turn on the power supply.
- 6) Blow the icemaker water supply line out using the compressed air or carbon dioxide supply.
- 7) Close the icemaker water supply line drain valve.

2. Remove the water from the water tank:

- 1) Turn off the power supply.
- 2) Remove the front, apron, top, left side, and side insulation panels.
- 3) Move the control switch to the "OFF" position.
- 4) Remove the drain plug. See Fig. 14. Allow the water tank to drain.
- 5) Replace the drain plug in its correct position. Be careful not to cross thread the drain plug.
- 6) Replace the side insulation, left side, top, apron, and front panels in their correct positions.
- 7) Remove all ice from the dispenser unit/ice storage bin. Clean the dispenser unit/ice storage bin using a neutral cleaner. Rinse thoroughly after cleaning.

V. Disposal

The appliance contains refrigerant and must be disposed of in accordance with applicable national, state, and local codes and regulations. Refrigerant must be recovered by properly certified service personnel.

HOSHIZAKI AMERICA, INC.

618 Hwy. 74 South, Peachtree City, GA 30269 USA (P) 770.487.2331 (F) 770.487.3360 hoshizakiamerica.com 1A3072-021