



# HOSHIZAKI

## Service Manual

Modular Crescent Cuber  
Serenity Series

Model  
KMS-2000MLH

Including  
Condensing Unit Models  
SRK-20H/3



[hoshizakiamerica.com](http://hoshizakiamerica.com)

Number: 73188  
Issued: 8-30-2011  
Revised: 9-1-2016

**IMPORTANT**

Only qualified service technicians should install, service, and maintain the icemaker. No service or maintenance should be undertaken until the technician has thoroughly read this Service Manual. Failure to service and maintain the equipment in accordance with this manual may adversely affect safety, performance, component life, and warranty coverage.

Hoshizaki provides this manual primarily to assist qualified service technicians in the service and maintenance of the icemaker.

Should the reader have any questions or concerns which have not been satisfactorily addressed, please call, send an e-mail message, or write to the Hoshizaki Technical Support Department for assistance.

Phone: 1-800-233-1940; (770) 487-2331

Fax: 1-800-843-1056; (770) 487-3360

E-mail: techsupport@hoshizaki.com

HOSHIZAKI AMERICA, INC.

618 Highway 74 South

Peachtree City, GA 30269

Attn: Hoshizaki Technical Support Department

Web Site: [www.hoshizaki.com](http://www.hoshizaki.com)

**NOTE:** To expedite assistance, all correspondence/communication **MUST** include the following information:

- Model Number \_\_\_\_\_
- Serial Number \_\_\_\_\_
- Complete and detailed explanation of the problem.

## **IMPORTANT**

This manual should be read carefully before the icemaker is serviced or maintenance operations are performed. Only qualified service technicians should install, service, and maintain the icemaker. Read the warnings contained in this booklet carefully as they give important information regarding safety. Please retain this booklet for any further reference that may be necessary.

## **CONTENTS**

Important Safety Information .....	5
I. Specifications.....	7
A. Icemaker .....	7
1. KMS-2000MLH with SRK-20H.....	7
2. KMS-2000MLH with SRK-20H3 .....	8
B. Condensing Unit.....	9
1. SRK-20H.....	9
2. SRK-20H3 .....	10
II. General Information .....	11
A. Construction .....	11
1. Icemaker .....	11
2. Condensing Unit .....	12
B. Sequence of Operation .....	13
1. Sequence Cycles and Shutdown .....	13
a) 1-Minute Fill Cycle .....	13
b) Initial Harvest Cycle .....	13
c) Freeze Cycle .....	13
d) Pump-Out Cycle.....	14
e) Harvest Cycle .....	14
f) Shutdown.....	15
2. Sequence Flow Chart.....	16
C. Control Board .....	17
1. Control Board Layout .....	18
2. LED Lights and Audible Alarm Safeties .....	19
3. Controls and Adjustments.....	20
a) Default Dip Switch Settings.....	20
b) Harvest Timer (S1 dip switch 1 & 2).....	20
c) Pump-Out Timer (S1 dip switch 3 & 4).....	21
d) Pump-Out Frequency Control (S1 dip switch 5 & 6).....	21
e) Harvest Pump Timer (S1 dip switch 7 & 8) .....	22
f) Freeze Timer (S1 dip switch 9 & 10) .....	22
g) Pump-Out/Drain Selector (S2 dip switch 1) .....	23
h) Float Switch Selector (S2 dip switch 2).....	23
i) Refill Counter (S2 dip switch 3 & 4).....	23
j) Anti-Slush Program Selector (S2 dip switch 5).....	24
k) Anti-Slush Control (S2 dip switch 6).....	24

D. Control and Service Switches .....	25
1. Control Switch .....	25
2. Service Switch .....	25
a) DRAIN.....	25
b) CIRC. ....	25
c) WASH.....	25
III. Technical Information .....	26
A. Water Circuit and Refrigeration Circuit .....	26
B. Wiring Diagrams .....	27
1. KMS-2000MLH with SRK-20H.....	27
2. KMS-2000MLH with SRK-20H3 .....	28
3. Wire Harness Connections .....	29
C. Performance Data .....	30
1. KMS-2000MLH with SRK-20H .....	30
2. KMS-2000MLH with SRK-20H3 .....	31
IV. Service Diagnosis .....	32
A. Diagnostic Procedure .....	32
B. Control Board Check .....	36
C. Bin Control Check and Cleaning .....	37
1. Bin Control Check .....	37
2. Bin Control Cleaning.....	38
D. Float Switch Check and Cleaning .....	39
1. Float Switch Check .....	39
2. Float Switch Cleaning.....	40
E. Thermistor Check.....	41
F. Diagnostic Charts .....	42
1. No Ice Production.....	42
2. Freeze-Up.....	43
3. Low Ice Production .....	45
V. Replacement of Components .....	47
A. Service for Refrigerant Lines.....	47
1. Refrigerant Recovery .....	47
2. Brazing .....	48
3. Evacuation and Recharge (R-404A).....	48
B. Important Notes for Component Replacement.....	50
VI. Cleaning and Maintenance .....	51
A. Cleaning and Sanitizing Instructions .....	51
1. Cleaning Procedure.....	51
2. Sanitizing Procedure - Following Cleaning Procedure .....	53
B. Maintenance.....	54
C. Preparing the Icemaker for Long Storage .....	55

---

## Important Safety Information

Throughout this manual, notices appear to bring your attention to situations which could result in death, serious injury, damage to the unit, or damage to property.

**⚠ WARNING** Indicates a hazardous situation which could result in death or serious injury.

**NOTICE** Indicates a situation which could result in damage to the unit or property.

**IMPORTANT** Indicates important information about the use and care of the unit.

### ⚠ WARNING

This icemaker should be destined only to the use for which it has been expressly conceived. Any other use should be considered improper and therefore dangerous. The manufacturer cannot be held responsible for injury or damage resulting from improper, incorrect, and unreasonable use.

**To reduce the risk of death, electric shock, serious injury, or fire, follow basic precautions including the following:**

- Only qualified service technicians should install, service, and maintain the icemaker.
- Move the control switch to the "OFF" position and turn off the power supply to the SRK condensing unit before servicing the KMS or SRK. Place the KMS disconnect (if applicable) in the off position. Lockout/Tagout to prevent the power supply from being turned back on inadvertently.
- Do not make any alterations to the unit. Alterations could result in electric shock, injury, fire, or damage to the unit.

#### **For KMS**

- Power supply and ground connection are supplied from the SRK remote condensing unit via the wire harness provided. Do not connect the wire harness leads to an external power source.
- Wire harness routing (conduit) and disconnect (if required) must meet national, state, and local electrical code requirements. Failure to meet these code requirements could result in death, electric shock, serious injury, fire, or severe damage to equipment.
- **THE ICEMAKER MUST BE GROUNDED.** Failure to properly ground the icemaker could result in death, serious injury, or damage to equipment.

### **For SRK**

- Electrical connection must be hard-wired and must meet national, state, and local electrical code requirements. Failure to meet these code requirements could result in death, electric shock, serious injury, fire, or damage to equipment.
- The remote condensing unit requires an independent power supply of proper capacity. See the nameplate for electrical specifications. Failure to use a properly sized breaker or fuse can result in a tripped breaker, blown fuses, or damage to existing wiring. This could lead to heat generation or fire.
- **THE REMOTE CONDENSING UNIT MUST BE GROUNDED.** Failure to properly ground the remote condensing unit could result in death or serious injury.

# I. Specifications

## A. Ice maker

### 1. KMS-2000MLH with SRK-20H

AC SUPPLY VOLTAGE	115VAC Supplied by SRK-20H via Factory Supplied		
AMPERAGE	Wire Harness		
MINIMUM CIRCUIT AMPACITY	21.3 A (5 Min. Freeze AT 104°F/WT 80°F)		
MAXIMUM FUSE SIZE	30 A		
APPROXIMATE ICE PRODUCTION PER 24 HR.	Ambient Temp.(°F)	WATER TEMP. (°F)	
lb/day ( kg/day )		50	70
Reference without *marks	70	*1861 (844)	1842 (835)
	80	1846 (837)	1816 (824)
	90	1842 (835)	*1795 (814)
	100	1786 (810)	1759 (798)
SHAPE OF ICE	Crescent Cube		
ICE PRODUCTION PER CYCLE	27.9 lb (12.6 kg) 1560 pcs.		
APPROXIMATE STORAGE CAPACITY	N/A		
ELECTRIC & WATER CONSUMPTION	90/70°F	70/50°F	
ELECTRIC W (kWH/100 lb)	3520(4.70)	3330(4.30)	
WATER gal/24HR (gal/100 lb)	395(22.0)	864(46.4)	
CEE TIER LEVEL	1		
ENERGY STAR	YES		
EXTERIOR DIMENSIONS (WxDxH)	30"x24"x32.9" (762x610x836 mm)		
EXTERIOR FINISH	Stainless Steel, Galvanized Steel (Rear)		
WEIGHT	Net 171 lb (78 kg), Shipping 206 lb (93 kg)		
CONNECTIONS - ELECTRIC	Wire Harness Connection from SRK to KMS		
- WATER SUPPLY	Inlet	1/2" FPT	
- DRAIN	Outlet	3/4" FPT	
-CONDENSATION		5/8" O.D. Hard Tube	
-REFRIGERATION	Liquid Line	1/2" Copper Tube Field Connection	
	Suction Line	3/4" Copper Tube Field Connection	
CUBE CONTROL SYSTEM	Float Switch		
HARVESTING CONTROL SYSTEM	Hot Gas and Water, Thermistor and Timer		
ICE MAKING WATER CONTROL	Timer Controlled. Overflow Pipe		
COOLING WATER CONTROL	N/A		
BIN CONTROL SYSTEM	Mechanical Level Switch and Timer		
COMPRESSOR	Hermetic, Model CS24K6E-PFV-275		
CONDENSER	Air-Cooled Remote, Condensing Unit SRK-20H		
EVAPORATOR	Vertical Type, Stainless Steel and Copper		
REFRIGERANT CONTROL	Thermostatic Expansion Valve		
	Headmaster (C.P.R.) in SRK-20H (190 PSIG)		
REFRIGERANT CHARGE	R404A, 27 lb 5.4 oz (12400 g)		
	(Ice maker 0 lb 7 oz (200 g))		
	(Condensing Unit 26 lb 14.3 oz (12600 g))		
DESIGN PRESSURE	High 467PSIG, Low 230PSIG		
P.C. BOARD CIRCUIT PROTECTION	High Voltage Cut-Out (Internal)		
LOW WATER PROTECTION	Float Switch		
ACCESSORIES -SUPPLIED	N/A		
-REQUIRED	Dispenser Unit or Ice Storage Bin		
	Condensing Unit: SRK-20H		
OPERATING CONDITIONS	VOLTAGE RANGE	187-253VAC	
	AMBIENT TEMP.		
	KMS-2000MLH	45-100°F	
	SRK-20H (Outdoor Use)	-20-122°F	
	WATER SUPPLY TEMP.	45-90°F	
	WATER SUPPLY PRESSURE	10-113 PSIG	

Note: We reserve the right to make changes in specifications and design without prior notice.

## 2. KMS-2000MLH with SRK-20H3

AC SUPPLY VOLTAGE	115VAC Supplied by SRK-20H3 via Factory Supplied Wire Harness		
AMPERAGE	11.0 A (5 Min. Freeze AT 104°F/WT 80°F)		
MINIMUM CIRCUIT AMPACITY	20 A		
MAXIMUM FUSE SIZE	20 A		
APPROXIMATE ICE PRODUCTION PER 24 HR.	Ambient Temp.(°F)	WATER TEMP. (°F)	
lb/day ( kg/day )		50	70
Reference without *marks	70	*1910 (866)	1850 (839)
	80	1864 (846)	1772 (804)
	90	1850 (839)	*1706 (774)
	100	1833 (831)	1686 (765)
SHAPE OF ICE	Crescent Cube		
ICE PRODUCTION PER CYCLE	27.4 lb (12.4 kg) 1560 pcs.		
APPROXIMATE STORAGE CAPACITY	N/A		
ELECTRIC & WATER CONSUMPTION	90/70°F	70/50°F	
ELECTRIC W (kWH/100 lb.)	3310(4.65)	3290(4.14)	
WATER gal/24HR (gal/100 lb)	397(23.3)	917(48.0)	
CEE TIER LEVEL	1		
ENERGY STAR	YES		
EXTERIOR DIMENSIONS (WxDxH)	30"x24"x32.9" (762x610x836 mm)		
EXTERIOR FINISH	Stainless Steel, Galvanized Steel (Rear)		
WEIGHT	Net 171 lb (78 kg), Shipping 206 lb (93 kg)		
CONNECTIONS - ELECTRIC	Wire Harness Connection from SRK to KMS		
- WATER SUPPLY	Inlet	1/2" FPT	
- DRAIN	Outlet	3/4" FPT	
-CONDENSATION		5/8" O.D. Hard Tube	
-REFRIGERATION	Liquid Line	1/2" Copper Tube Field Connection	
	Suction Line	3/4" Copper Tube Field Connection	
CUBE CONTROL SYSTEM	Float Switch		
HARVESTING CONTROL SYSTEM	Hot Gas and Water, Thermistor and Timer		
ICE MAKING WATER CONTROL	Timer Controlled. Overflow Pipe		
COOLING WATER CONTROL	N/A		
BIN CONTROL SYSTEM	Mechanical Level Switch and Timer		
COMPRESSOR	Hermetic, Model CS24K6E-TF5-275		
CONDENSER	Air-Cooled Remote, Condenser Unit SRK-20H3		
EVAPORATOR	Vertical Type, Stainless Steel and Copper		
REFRIGERANT CONTROL	Thermostatic Expansion Valve		
	Headmaster (C.P.R.) in SRK-20H3 (190 PSIG)		
REFRIGERANT CHARGE	R404A, 27 lb 5.4 oz (12400 g)		
	(Icemaker 0 lb 7 oz (200 g))		
	(Condensing Unit 26 lb 14.3 oz (12600 g))		
DESIGN PRESSURE	High 467PSIG, Low 230PSIG		
P.C. BOARD CIRCUIT PROTECTION	High Voltage Cut-Out (Internal)		
LOW WATER PROTECTION	Float Switch		
ACCESSORIES -SUPPLIED	N/A		
-REQUIRED	Dispenser Unit or Ice Storage Bin		
	Condensing Unit: SRK-20H3		
OPERATING CONDITIONS	VOLTAGE RANGE	187-253VAC	
	AMBIENT TEMP.		
		KMS-2000MLH	45-100°F
		SRK-20H3 (Outdoor Use)	-20-122°F
	WATER SUPPLY TEMP.	45-90°F	
	WATER SUPPLY PRESSURE	10-113 PSIG	

Note: We reserve the right to make changes in specifications and design without prior notice.



## B. Condensing Unit

### 1. SRK-20H

AC SUPPLY VOLTAGE	208-230/60/1 (3 wire with neutral for 115VAC) (115VAC Supplied to KMS via Factory Wire Harness)		
AMPERAGE	21.3 A (5 Min. Freeze AT 104°F/WT 80°F)		
MINIMUM CIRCUIT AMPACITY	30 A		
MAXIMUM FUSE SIZE	30 A		
EXTERIOR DIMENSIONS (WxDxH)	59.7"x17"x30" (1517x431x762 mm)		
DIMENSIONS INCLUDING LEGS (WxDxH)	62"x21"x45" (1575x533x1142 mm)		
EXTERIOR FINISH	Galvanized Steel		
WEIGHT	Net 280 lb (127 kg)	Shipping 325 lb (147 kg)	
CONNECTIONS - ELECTRIC	Main Power Supply: Permanent Connection SRK to KMS: Wire Harness Connection		
- REFRIGERANT	Liquid line	1/2" Copper Tube Field Connection	
	Suction line	3/4" Copper Tube Field Connection	
COMPRESSOR	Hermetic, Model CS24K6E-PFV-275		
CONDENSER	Air Cooled, Fin and Tube Type		
COMPRESSOR PROTECTION	Auto-Reset Overload Protector (Internal)		
FAN MOTOR PROTECTION	Thermal Protection		
REFRIGERANT CIRCUIT PROTECTION	Auto-Reset High-Pressure Switch Auto-Reset Discharge Line Thermostat		
REFRIGERANT CONTROL	Headmaster (C.P.R.) (190 PSIG)		
REFRIGERANT CHARGE	R404A, 27 lb 5.4 oz (12400 g) (Condensing Unit 26 lb 14.3 oz (12600 g)) (Icemaker 0 lb 7.0 oz) (200 g))		
DESIGN PRESSURE	High 467 PSIG, Low 230 PSIG		
OPERATING CONDITIONS	VOLTAGE RANGE	187-253VAC	
	AMBIENT TEMP. ( Outdoor use )	-20-122°F	
ACCESSORIES -SUPPLIED	Leg		2 pcs
	Hex Head Bolt w/Washer	M8x16	16 pcs
	Hex Nut	M8	16 pcs
-REQUIRED	Compatible KMS Icemaker		

Note: We reserve the right to make changes in specifications and design without prior notice.

## 2. SRK-20H3

AC SUPPLY VOLTAGE	208-230/60/3 (115VAC Supplied to KMS via Factory Wire Harness)		
AMPERAGE	11.0 A (5 Min. Freeze AT 104°F/WT 80°F)		
MINIMUM CIRCUIT AMPACITY	20 A		
MAXIMUM FUSE SIZE	20 A		
EXTERIOR DIMENSIONS (WxDxH)	59.7"x17"x30" (1517x431x762 mm)		
DIMENSIONS INCLUDING LEGS (WxDxH)	62"x21"x45" (1575x533x1142 mm)		
EXTERIOR FINISH	Galvanized Steel		
WEIGHT	Net 280 lb ( 127 kg )	Shipping 325 lb ( 147 kg )	
CONNECTIONS - ELECTRIC	Main Power Supply: Permanent Connection SRK to KMS: Wire Harness Connection		
- REFRIGERANT	Liquid line	1/2" Copper Tube Field Connection	
	Suction line	3/4" Copper Tube Field Connection	
COMPRESSOR	Hermetic, Model CS24K6E-TF5-275		
CONDENSER	Air Cooled, Fin and Tube Type		
COMPRESSOR PROTECTION	Auto-Reset Overload Protector (Internal)		
FAN MOTOR PROTECTION	Thermal Protection		
REFRIGERANT CIRCUIT PROTECTION	Auto-Reset High-Pressure Switch Auto-Reset Discharge Line Thermostat		
REFRIGERANT CONTROL	Headmaster (C.P.R.) (190 PSIG)		
REFRIGERANT CHARGE	R404A, 27 lb 5.4 oz (12400 g) (Condensing Unit 26 lb 14.3 oz (12600 g)) (Icemaker 0 lb 7.0 oz) (200 g))		
DESIGN PRESSURE	High 467 PSIG, Low 230 PSIG		
OPERATING CONDITIONS	VOLTAGE RANGE	187-253VAC	
	AMBIENT TEMP. ( Outdoor use )	-20-122°F	
ACCESSORIES -SUPPLIED	Leg		2 pcs
	Hex. Head Bolt w/Washer	M8 x 16	16 pcs
	Hex. Nut	M8	16 pcs
- REQUIRED	Compatible KMS Icemaker		

Note: We reserve the right to make changes in specifications and design without prior notice.

## II. General Information

### A. Construction

#### 1. Icemaker

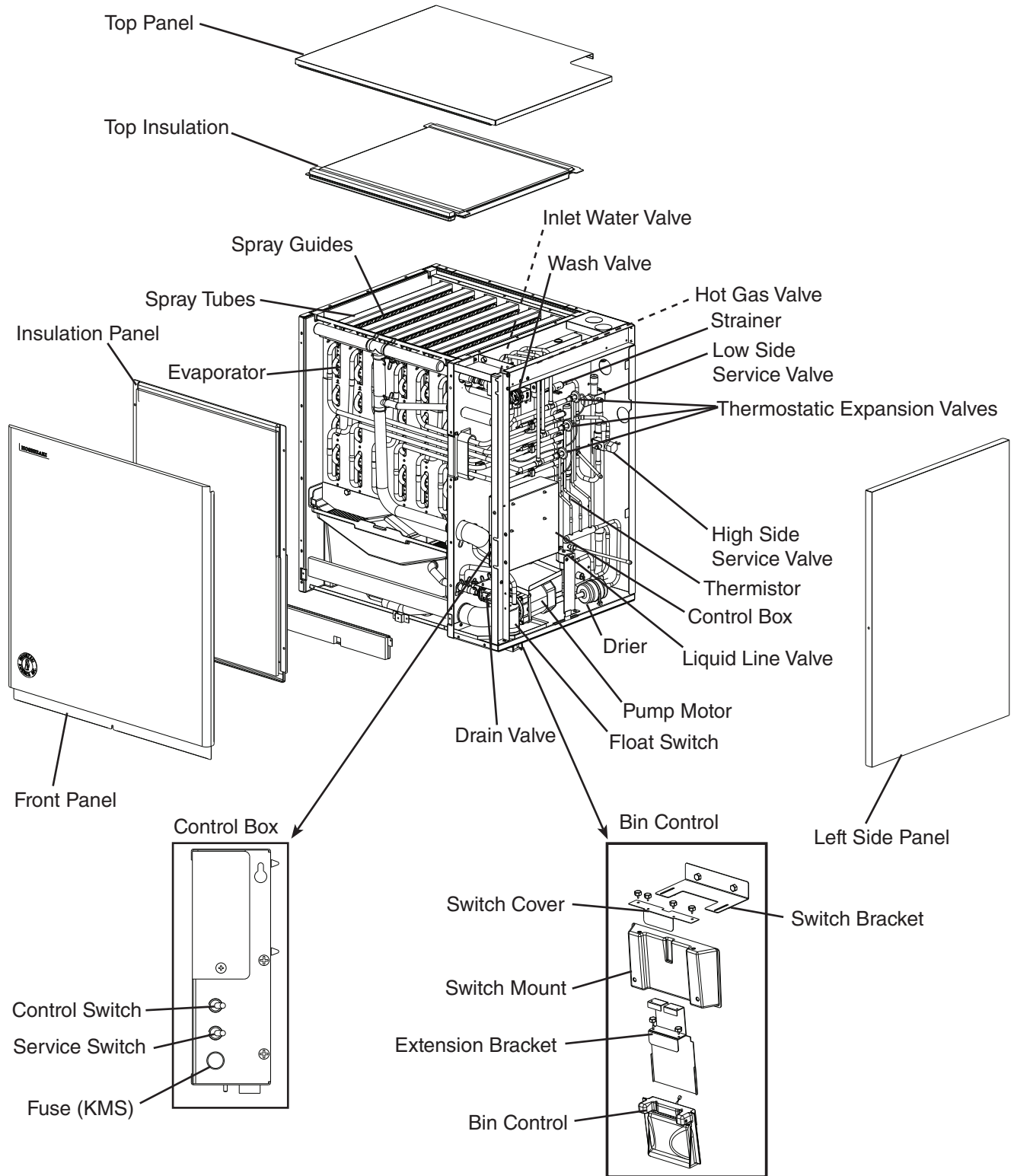

## 2. Condensing Unit

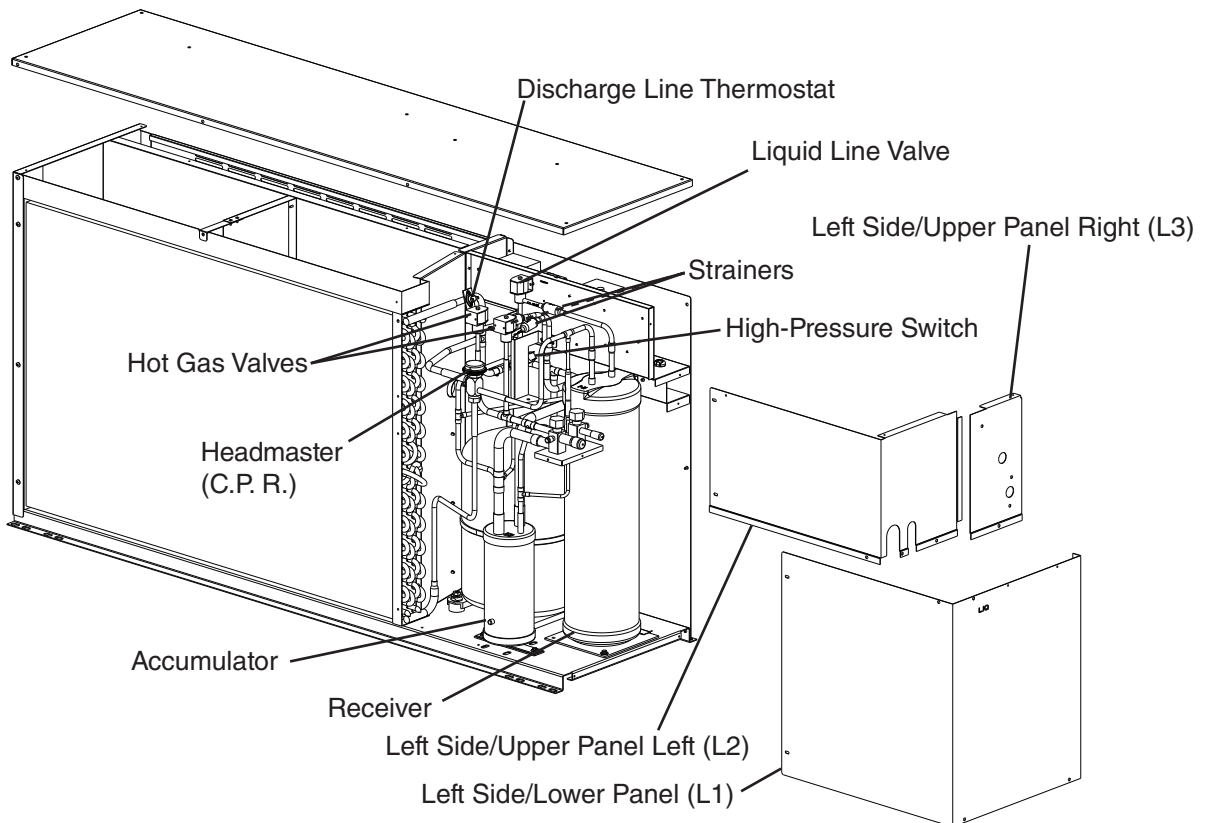
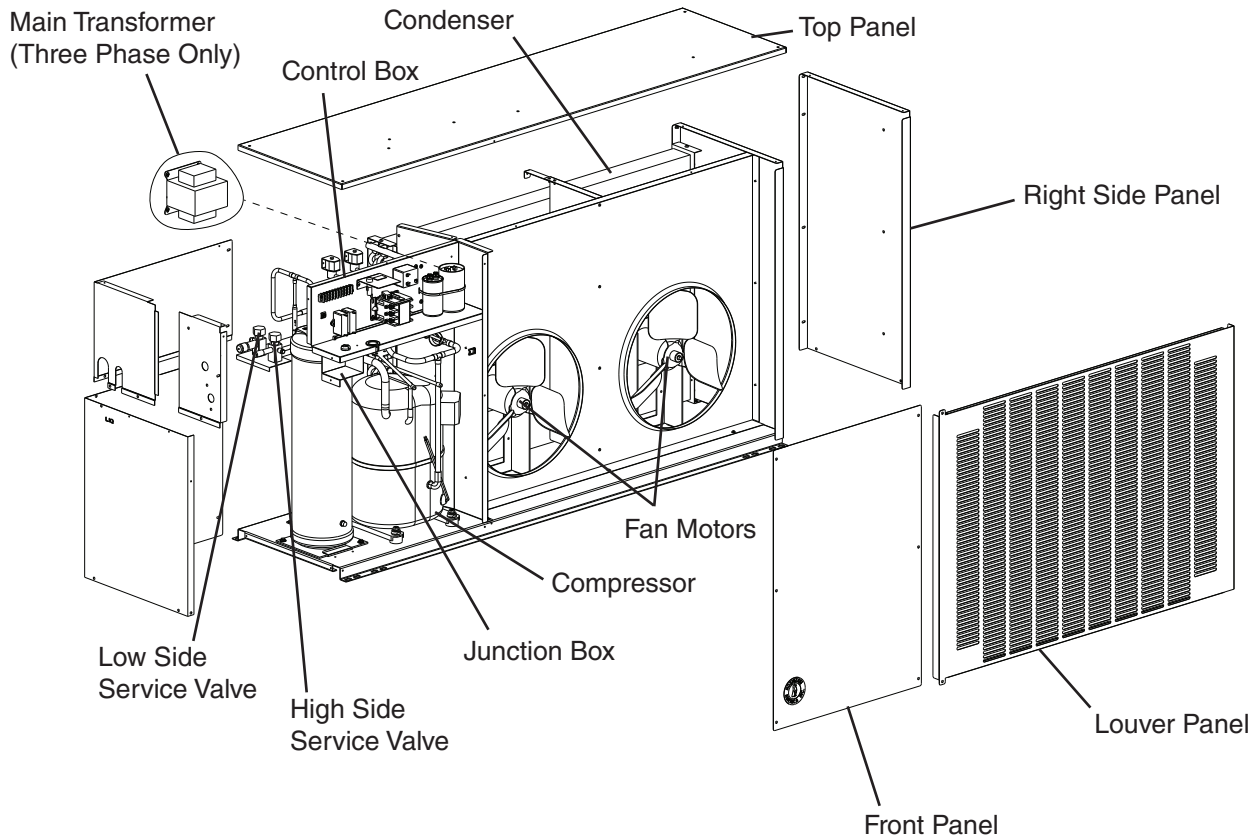

## B. Sequence of Operation

### 1. Sequence Cycles and Shutdown

The steps in the sequence are as outlined below. When power is supplied, CB red "POWER OK" LED turns on. If CB red "POWER OK" LED is flashing, the unit will not start. In this case, clear ice away from the BC actuator paddle in the dispenser unit/storage bin area. A 5-second delay occurs at startup. Note that the order of the component LEDs from the outer edge of CB is 5, 6, 8, 9, 4, 7.

#### a) 1-Minute Fill Cycle

**LED 8 is on.** WV energizes. After 1 minute, CB checks for a closed F/S. If F/S is closed, the harvest cycle begins. If not, WV remains energized through additional 1-minute fill cycles until water fills the water tank and closes F/S. This serves as a low water safety to protect PM.

#### b) Initial Harvest Cycle

**LEDs 5, 6, and 8 are on.** WV remains energized. Comp, FMRs, HGVs energize. CB monitors the warming of the evaporator via the thermistor located on the suction line. When the thermistor reaches 48°F (9°C), CB reads 3.9 kΩ from the thermistor and turns harvest termination over to the harvest timer. For details, see "II.C.3.b) Harvest Timer (S1 dip switch 1 & 2)." The pump-out timer acts in place of the harvest timer during cycles with a pump-out. For details, see "II.C.3.c) Pump-Out Timer (S1 dip switch 3 & 4)." WV is energized during harvest for a maximum of 6 minutes or the length of harvest minus 50 seconds, whichever is shorter. For details, see "II.C.3.e) Harvest Pump Timer (S1 dip switch 7 & 8)." 50 seconds before the harvest timer terminates, LED 8 turns off and WV de-energizes.

**Harvest Pump Timer: LEDs 5, 6, and 7 are on.** LED 7 turns on and PM energizes. Comp, FMRs, and HGVs remain energized. When the harvest timer terminates, the harvest cycle is complete. CB checks the position of F/S and proceeds to the freeze cycle if it is closed or calls for a 1-minute fill cycle if it is open. The minimum total time allowed by CB for a complete harvest cycle is 2 minutes.

#### c) Freeze Cycle

**LEDs 5 & 7 are on.** Comp, FMRs, and PM remain energized. LLVs energize, HGVs de-energize. CB monitors the cooling of the evaporator via the thermistor located on the suction line. When the temperature drops to 36°F (2°C), CB reads 5.5 kΩ from the thermistor and starts the 5-minute short cycle protection timer. CB does not monitor F/S until the 5-minute short cycle protection timer terminates. After the 5-minute short cycle protection timer terminates, CB 1-minute default refill timer starts (LED 9 is on during CB 1-minute default refill). The KMS-2000MLH is not wired for the 1-minute default refill. When CB 1-minute default refill timer terminates, CB turns freeze termination over to F/S. As ice builds on the evaporator, the water level in the water tank lowers. The freeze cycle continues until F/S is open for 15 continuous seconds.

**Anti-Slush Control: LED 5 is on.** Comp, FMRs, and LLVs remain energized. PM de-energizes for 10 seconds. CB monitors the cooling of the evaporator via the thermistor located on the suction line. When the temperature drops to 34°F (1°C), CB reads 5.8 kΩ from the thermistor, then LED 7 turns off and PM de-energizes for 10 seconds. **NOTICE! Do not adjust S2 dip switch 5 and 6 out of the factory default position on this model.** This setting helps prevent slushing during the freeze cycle.

**d) Pump-Out Cycle**

**LEDs 5, 6, 4, and 7 are on.** Comp and FMRs remain energized, HGVs energize. LLVs de-energize. PM de-energizes for 2 seconds. When S2 dip switch 1 is in the on position, PM and DV energize. **NOTICE! Do not adjust S2 dip switch 1 out of the factory default position on this model. This dip switch must be left in the factory default position or this unit will not operate correctly.** For details, see "II.C.3.g) Pump-Out/Drain Selector (S2 dip switch 1)." PM takes water from the water tank and pumps it through DV and down the drain. At the same time, water flows through the small F/S tube to power flush F/S. Pump-out lasts for 10 seconds. When the pump-out timer terminates, pump-out is complete.

The first pump-out occurs after the 1st freeze cycle, then every 10th cycle thereafter. The pump-out timer and pump-out frequency control are factory set, and generally no adjustment is required. However, where water quality is bad and the icemaker needs a longer and/or more frequent pump-out, the pump-out timer and pump-out frequency control can be adjusted. The pump-out timer can be set to have a 10 or 20 second pump-out. For details, see "II.C.3.c) Pump-Out Timer (S1 dip switch 3 & 4)." The pump-out frequency control can be set to have a pump-out occur every cycle, or every 2, 5, or 10 cycles. For details, see "II.C.3.d) Pump-Out Frequency Control (S1 dip switch 5 & 6)."

**e) Harvest Cycle**

Same as the initial harvest cycle. See "II.B.1.b) Initial Harvest Cycle."

Note: Unit continues to cycle until BC is satisfied or power is turned off. The unit always restarts at the 1-minute fill cycle.

**f) Shutdown**

**LEDs 4 and 7 are on:** When BC is activated (BC open), CB red "POWER OK" LED flashes. There is a delay before the shutdown sequence begins. The delay varies depending on the cycle the icemaker is in at the time of activation. For details, see the table below.

Cycle at Bin Control Activation	Delay Before Shutdown Sequence Begins
Fill Cycle	15 seconds
Harvest Cycle	15 seconds after the next freeze cycle starts
Freeze Cycle	15 seconds if BC is activated between the beginning of freeze and termination of the 5-minute short cycle protection timer (timer starts when the thermistor temperature drops to 36°F (2°C) (5.5 kΩ or more)). After this time, the unit will not shut down until the next harvest cycle is complete.

After the shutdown delay, all components de-energize. 2 seconds later, DV and PM energize. PM takes water from the water tank and pumps it through DV and down the drain. **NOTICE! Do not adjust S2 dip switch 1 out of the factory default position on this model. This dip switch must be left in the factory default position or this unit will not operate correctly.** For details, see "II.C.3.g) Pump-Out/Drain Selector (S2 dip switch 1)." The water tank drains for a maximum of 5 minutes or until F/S opens. DV and PM then de-energize. When BC closes again calling for ice, the unit starts at the 1-minute fill cycle. There is a 90-second minimum off time before the icemaker can restart.

Legend: **BC**—bin control; **CB**—control board; **Comp**—compressor; **DV**—drain valve; **FMRs**—fan motors-remote; **F/S**—float switch; **HGVs**—hot gas valves; **LLVs**—liquid line valves; **PM**—pump motor; **WV**—inlet water valve



## 2. Sequence Flow Chart

### "H" Control Board Sequence Flow Chart KMS-2000MLH with SRK-20H/3

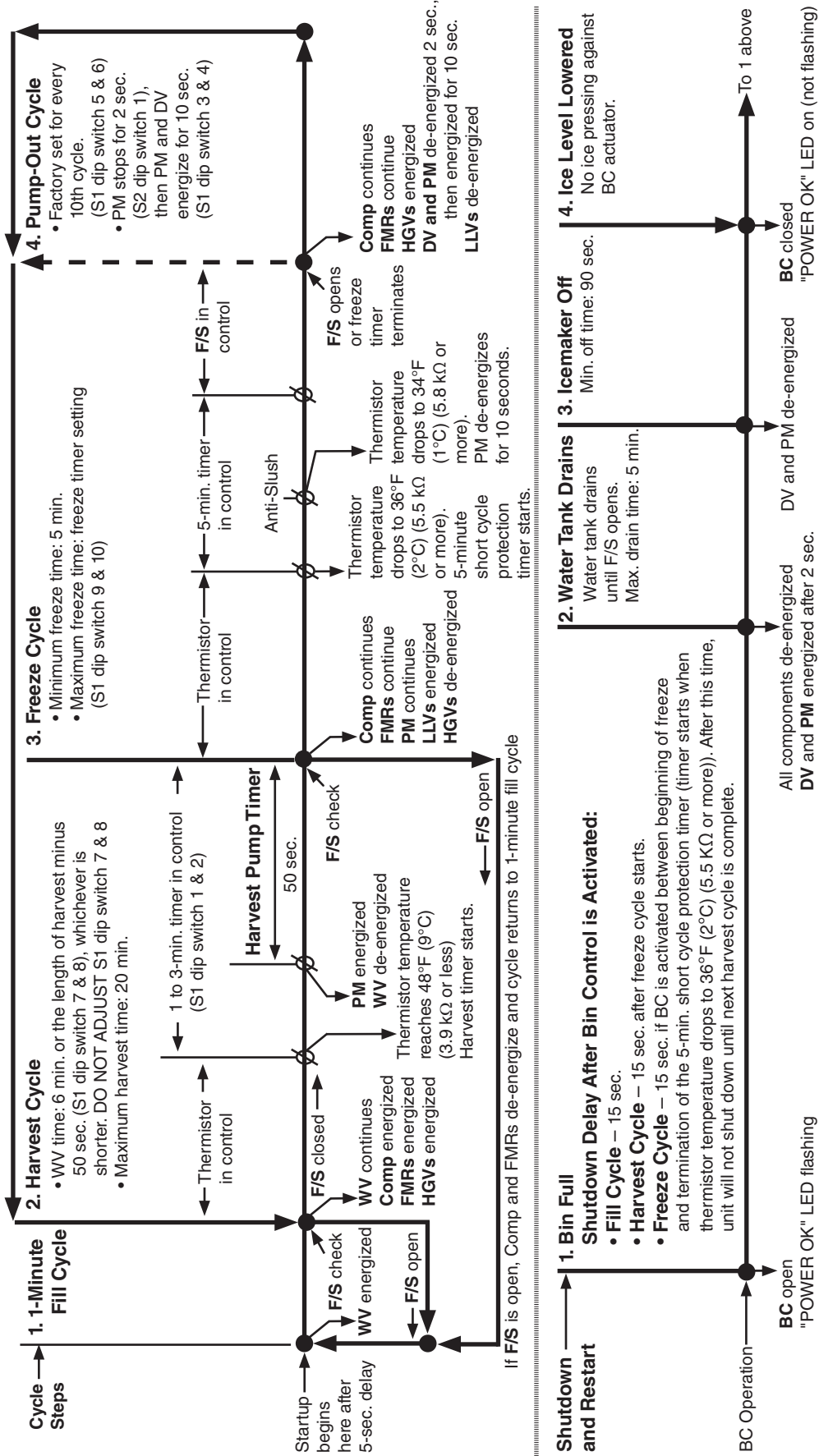

#### Legend:

- BC-bin control
- Comp-compressor
- DV-drain valve
- FMRs-fan motors-remote
- F/S-float switch
- HGVs-hot gas valves (KMS and SRK)
- LLVs-liquid line valves (KMS and SRK)
- PM-pump motor
- WV-inlet water valve

#### Components Energized when the Control Switch is in the "SERVICE" Position

When in the "SERVICE" position, the control switch supplies power to the service switch and the icemaker is in service mode. The service switch has three positions: "DRAIN," "CIRC." and "WASH." See the information below for details of each function.

DRAIN	Power is supplied to the pump motor and drain valve. This drains the water tank.
CIRC.	Power is supplied to the pump motor only. This operation can be used to circulate cleaner and sanitizer over the outside surface of the evaporator for extended periods of time.
WASH	Power is supplied to the pump motor and wash valve. This operation is used to circulate cleaner and sanitizer over both the inside and outside surfaces of the evaporator.



## C. Control Board

- A Hoshizaki exclusive control board is employed in Hoshizaki Crescent Cubers.
- All models are pretested and factory-adjusted.
- For a control board check procedure, see "IV.B. Control Board Check."

### **NOTICE**

1. The control board is fragile; handle very carefully.
2. The control board contains integrated circuits, which are susceptible to failure due to static discharge. It is especially important to touch the metal part of the unit before handling or replacing the control board.
3. Do not touch the electronic devices on the control board or the back of the control board.
4. Do not change wiring and connections.
5. Always replace the whole control board assembly if it goes bad.
6. Do not short out power supply to test for voltage.

# 1. Control Board Layout

## "H" Control Board

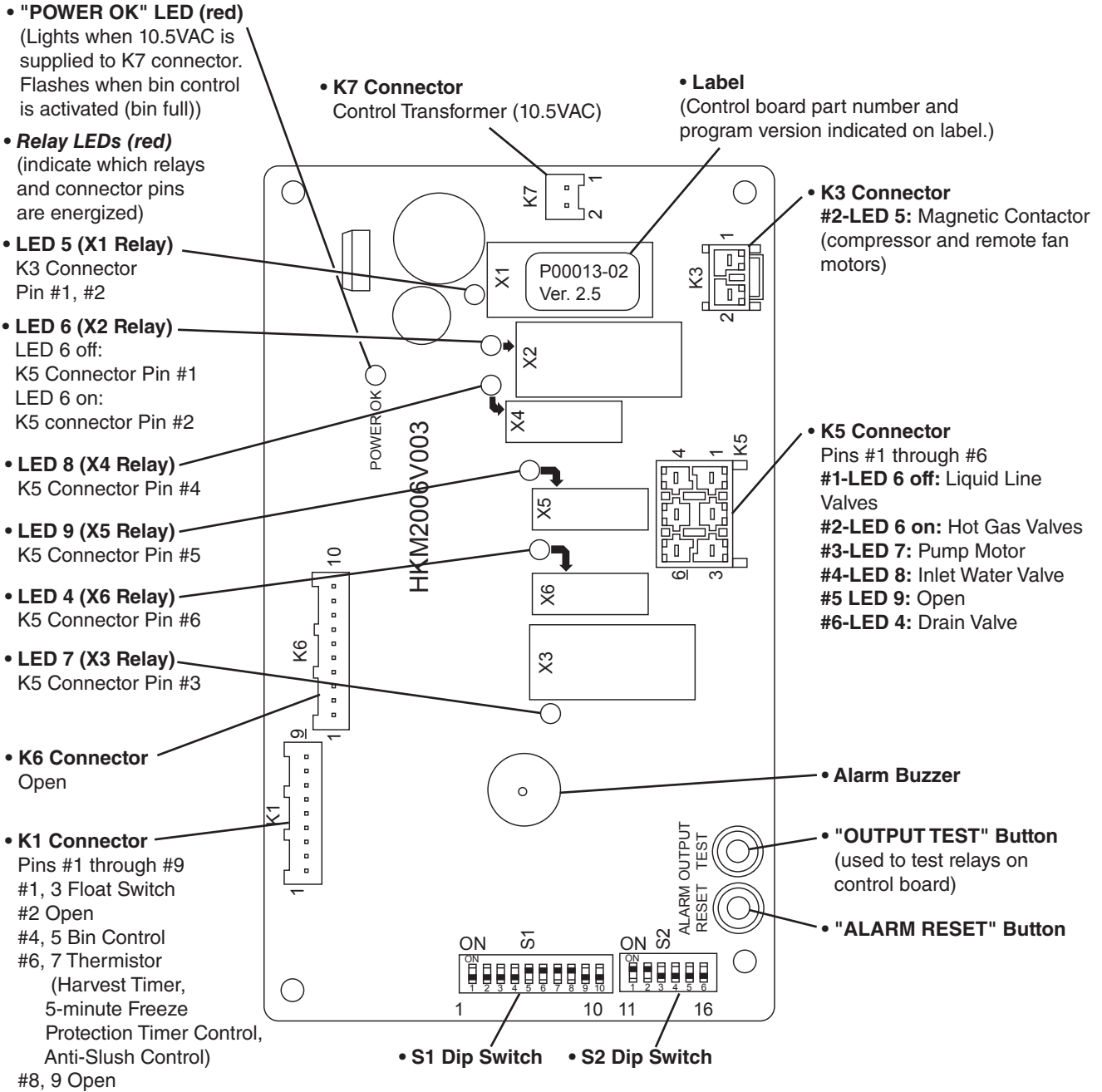

"H" Control Board		
Part Number	P00013-02	Version 2.5

## 2. LED Lights and Audible Alarm Safeties

At startup, a 5-second delay occurs. The red "POWER OK" LED indicates proper control voltage and remains on unless a control voltage problem occurs. The red "POWER OK" LED flashes continuously when the bin is full. LEDs 4 through 9 energize and sequence from initial startup as listed in the table below. Note that the order of the LEDs from the outer edge of the control board is 5, 6, 8, 9, 4, 7. For details, see "II.B. Sequence of Operation."

Sequence Step		LED	Energized Components	Time LEDs are On		
				Min.	Max.	Avg.
1-Minute Fill Cycle		8	WV			1 minute
Harvest Cycle		5, 6, 8	Comp, FMRs, HGVs, WV	2 minutes	20 minutes	3 to 5 minutes
Harvest Pump Timer		5, 6, 7	Comp, FMRs, HGVs, PM	0 seconds	50 seconds	harvest pump timer setting
Freeze Cycle	Freeze	5, 7, 9 (9 for 1-minute only)	Comp, FMRs, PM, LLVs	5 minutes	freeze timer setting	30 to 35 minutes
	Anti-Slush	5	Comp, FMRs, LLVs		10 seconds	
Pump-Out Cycle		5, 6, 4, 7*	Comp, FMRs, HGVs, DV, PM*	10 seconds	20 seconds	*pump-out/drain selector setting

The built in safeties shut down the unit and have alarms as listed below.

No. of Beeps (every 3 sec.)	Type of Alarm	Notes
1	High Evaporator Temp. (temperature > 127°F) (53°C))	Check for harvest problem (stuck HGVs), hot water entering unit, stuck HM, or shorted thermistor.
2	Harvest Backup Timer (harvest > 20 min. for two cycles in a row)	Check for open thermistor, HGVs not opening, TXVs or LLVs leaking by, low charge, or inefficient Comp.
3	Freeze Timer (freeze > specified setting for two cycles in a row) Freeze Timer is factory set using S1 dip switch 9 & 10	Check for a F/S stuck closed (up), WV leaking by, HGVs leaking by, PM not pumping, TXVs not feeding properly, LLVs not opening, low charge, HM not bypassing, or inefficient Comp.
To reset the above safeties, press the "ALARM RESET" button with the power supply on.		
6	Low Voltage (92VAC±5% or less)	Red "POWER OK" LED turns off if voltage protection operates.
7	High Voltage (147VAC±5% or more)	The control voltage safeties automatically reset when voltage is corrected.

Legend: **Comp**—compressor; **DV**—drain valve; **FMRs**—fan motors-remote; **F/S**—float switch; **HGVs**—hot gas valves; **HM**—headmaster (C.P.R.); **LLVs**—liquid line valves; **PM**—pump motor; **TXVs**—thermostatic expansion valves; **WV**—inlet water valve

### 3. Controls and Adjustments

#### **NOTICE**

Dip switches are factory set. Failure to maintain factory settings may adversely affect performance and warranty coverage. For more information, contact Hoshizaki Technical Support at 1-800-233-1940.

#### a) **Default Dip Switch Settings**

The dip switches are factory-adjusted to the following positions:

S1 Dip Switch										
Model	S1 Dip Switch No.									
	1	2	3	4	5	6	7	8	9	10
KMS-2000MLH	OFF	OFF	OFF	OFF	ON	ON	ON	ON	OFF	OFF

S2 Dip Switch						
Model	S2 Dip Switch No. (Do Not Adjust)					
	1	2	3	4	5	6
KMS-2000MLH	ON	ON	OFF	OFF	OFF	OFF

#### **S1 Dip Switch**

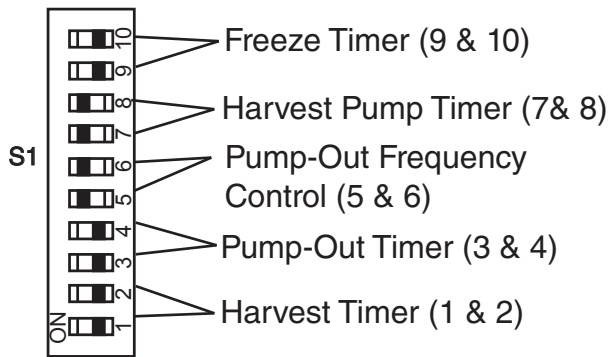

#### **S2 Dip Switch**

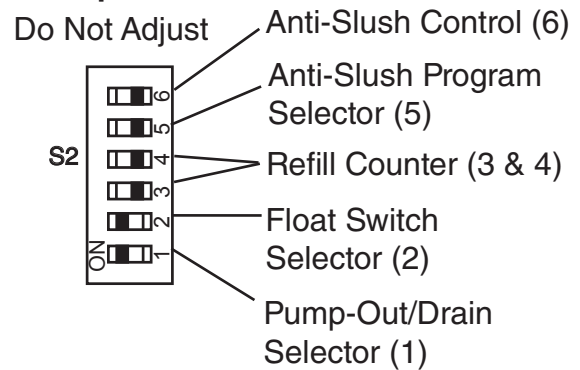

#### b) **Harvest Timer (S1 dip switch 1 & 2)**

The harvest timer starts when the thermistor reaches 48°F (9°C) at the evaporator outlet and the control board reads 3.9 kΩ from the thermistor. The harvest timer is factory set, and generally no adjustment is required. However, a setting longer than the factory setting may be advised in cases where harvest needs to be prolonged for extra cleaning. Before changing this setting, contact Hoshizaki Technical Support at 1-800-233-1940 for recommendations. Keep in mind that setting the harvest timer to a longer setting decreases 24-hour production.

The pump-out timer (S1 dip switch 3 & 4) acts in place of the harvest timer during cycles with a pump-out. For details, see "II.C.3.c) Pump-Out Timer (S1 dip switch 3 & 4)."

S1 Dip Switch Setting		Time (seconds)
No. 1	No. 2	
OFF	OFF	60
ON	OFF	90
OFF	ON	120
ON	ON	180

**c) Pump-Out Timer (S1 dip switch 3 & 4)**

When a pump-out is called for, the pump motor de-energizes for 2 seconds, then the pump motor and drain valve energize for 10/20 seconds. Water is removed from the bottom of the water tank and pumped down the drain through the drain valve. At the same time, water flows through the small float switch tube to power flush the float switch. The pump-out drains the water tank for the time determined by the pump-out timer. The pump-out timer also acts in place of the harvest timer during cycles with a pump-out. The pump-out timer is factory set, and generally no adjustment is required. However, where water quality is bad and the icemaker needs a longer pump-out, the pump-out timer can be adjusted. The pump-out timer can be set to have a 10 or 20 second pump-out.

S1 Dip Switch Setting		Time (seconds)	
No. 3	No. 4	T1	T2
OFF	OFF	10	120
ON	OFF	10	180
OFF	ON	20	120
ON	ON	20	180

T1: Time to drain the water tank

T2: Harvest timer at pump-out

**d) Pump-Out Frequency Control (S1 dip switch 5 & 6)**

The pump-out frequency control is factory-adjusted to drain the water tank every 10 cycles, and generally no adjustment is required. However, where water quality is bad and the icemaker needs a more frequent pump-out, the pump-out frequency can be adjusted as shown in the table below.

S1 Dip Switch Setting		Pump-Out Frequency
No. 5	No. 6	
OFF	OFF	Every cycle
ON	OFF	Every 2 cycles
OFF	ON	Every 5 cycles
ON	ON	Every 10 cycles

**e) Harvest Pump Timer (S1 dip switch 7 & 8)**

**NOTICE**

Factory set. Do not adjust. Adjustment outside of the factory default setting may result in damage to the icemaker.

Depending on the harvest pump timer setting, the pump motor stays off or energizes and runs for the last 10, 30, or 50 seconds of the harvest cycle. The water valve is energized during harvest for a maximum of 6 minutes or the length of harvest minus 0, 10, 30, or 50 seconds (determined by the harvest pump timer setting), whichever is shorter.

S1 Dip Switch Setting		Pump Motor Time (seconds)
No. 7	No. 8	
OFF	OFF	0
ON	OFF	10
OFF	ON	30
ON	ON	50

**f) Freeze Timer (S1 dip switch 9 & 10)**

**NOTICE**

Adjust to proper specification, or the unit may not operate correctly.

The freeze timer setting determines the maximum allowed freeze time to prevent possible freeze-up issues. Upon termination of freeze timer, the control board initiates the harvest cycle. After 2 consecutive freeze timer terminations, the control board shuts down the icemaker. In this case, see "IV.F.3. Low Ice Production" for possible solutions.

The freeze timer is factory set, and generally no adjustment is required. Before changing this setting, contact your local Hoshizaki distributor or Hoshizaki Technical Support at 1-800-233-1940 for recommendations.

Dip Switch Setting		Time (minutes)
No. 9	No. 10	
OFF	OFF	60
OFF	ON	70
ON	OFF	50
ON	ON	100

**g) Pump-Out/Drain Selector (S2 dip switch 1)**

**NOTICE**

Do not adjust. Factory set for proper operation. Adjustment outside of the factory default setting may result in damage to the icemaker.

The pump-out/drain selector setting determines whether the pump motor energizes (pump-out) or stays off (drain) after a 2-second delay at the beginning of the pump-out cycle or at shutdown. Regardless of the pump-out/drain selector setting, the drain valve energizes after a 2-second delay at the beginning of the pump-out cycle or at shutdown. When the pump-out/drain selector is set to pump-out, the pump motor energizes and takes water from the water tank and pumps it through the drain valve and down the drain. When the pump-out/ drain selector is set to drain, water drains by gravity through the drain valve.

S2 Dip Switch Setting	Pump-Out/ Drain
<b>No. 1</b>	
OFF	Drain
ON	Pump-Out

**h) Float Switch Selector (S2 dip switch 2)**

**NOTICE**

Do not adjust. This must be left in the factory default position.

On units with a double float switch, the float switch selector determines which float switch (upper or lower) the control board monitors for refill initiation during the freeze cycle, and the refill counter (S2 dip switch 3 & 4) determines the number of refills. The KMS-2000MLH uses a single float switch with a double float switch/upper float switch refill setting. The KMS-2000MLH does not refill. When the 5-minute short cycle protection timer terminates, the control board checks the upper float switch. If an upper float switch exists, refill is initiated by an open upper float switch and is terminated by a closed upper float switch. In a single float switch application with a double float switch/upper float switch refill setting, no upper float switch exists, therefore the control board reads an open upper float switch and initiates a 1-minute default refill. The KMS-2000MLH is not wired for the 1-minute default refill. During the 1-minute default refill time, LED 9 is on. After the 1-minute default refill timer terminates, the refill counter setting is ignored for the rest of the freeze cycle.

S2 Dip Switch Setting	Float Switch Type	Refill Initiation with Double Float Switch
<b>No. 2</b>		
OFF	Single or Double	Lower Switch
ON	Double	Upper Switch

**i) Refill Counter (S2 dip switch 3 & 4)**

**NOTICE**

Do not adjust. These must be left in the factory default position.

The refill counter determines the number of refills during the freeze cycle. The KMS-2000MLH does not refill.

**j) Anti-Slush Program Selector (S2 dip switch 5)**

The anti-slush program selector determines which anti-slush program is used during the freeze cycle when the anti-slush control (S2 dip switch 6) is activated. The anti-slush control helps prevent slushing in the water tank during the freeze cycle.

S2 Dip Switch Settings	Pump Motor Operation	# of Times Pump Motor De-Energized	Temperature Anti-Slush Begins
No. 5			
OFF	10 Seconds Off	1	34°F (1°C)
ON	10 Sec. Off 50 Sec. On	Multiple	50°F (10°C)
	10 Sec. Off	2	34°F (1°C)
	50 Sec. On	1	

**S2 Dip Switch 5 "OFF" Program:** The control board monitors the cooling of the evaporator via the thermistor located on the suction line. When the temperature drops to 34°F (1°C), the control board reads 5.8 kΩ from the thermistor and de-energizes the pump motor for 10 seconds. This is the only time in the freeze cycle that the pump motor de-energizes.

**S2 Dip Switch 5 "ON" Program:** The control board monitors the cooling of the evaporator via the thermistor located on the suction line. When the temperature drops to 50°F (10°C), the control board reads 3.8 kΩ from the thermistor. The pump motor de-energizes for 10 seconds, then energizes for 50 seconds. This continues (10 sec. off/50 sec. on) until the temperature drops to 34°F (1°C). At 34°F (1°C), the control board reads 5.8 kΩ from the thermistor and performs the final off/on/off cycle. The pump motor then energizes for the remainder of the freeze cycle.

**k) Anti-Slush Control (S2 dip switch 6)**

**NOTICE**

Do not adjust. S2 dip switch 6 must be left in the factory default position. Otherwise, damage to the icemaker may occur.

When the anti-slush control is activated (S2 dip switch 6 "OFF"), the pump motor de-energizes during the freeze cycle according to the anti-slush program selector (S2 dip switch 5). The anti-slush control helps prevent slushing in the water tank during the freeze cycle. See "II.C.3.j) Anti-Slush Program Selector (S2 dip switch 5)."

S2 Dip Switch Settings	Anti-Slush
No. 6	
OFF	Activated
ON	Deactivated



## **D. Control and Service Switches**

The control switch and service switch are used to control the operation of this unit. They are located on the control box.

### **1. Control Switch**

The control switch has three positions: "OFF" for power off, "ICE" for icemaking, and "SERVICE" to activate the service switch.

### **2. Service Switch**

When the control switch is in the "SERVICE" position, the control switch supplies power to the service switch. The service switch has three positions: "DRAIN," "CIRC." and "WASH."

Note:

1. When the service switch is active (control switch in the "SERVICE" position), power is supplied to the pump motor in all three positions.
2. When the control switch is in the "OFF" or "ICE" position, the service switch is de-activated. In this state, the service switch can be left in any position.

#### **a) DRAIN**

When the service switch is active and in the "DRAIN" position, power is supplied to the pump motor and drain valve.

#### **b) CIRC.**

When the service switch is active and in the "CIRC." position, power is supplied to the pump motor only. This operation can be used to circulate cleaner for extended periods of time over the outside surface of the evaporator.

#### **c) WASH**

When the service switch is active and in the "WASH" position, power is supplied to the pump motor and wash valve. This operation is used to circulate cleaner and sanitizer over both the inside and outside of the evaporator.

### III. Technical Information

#### A. Water Circuit and Refrigeration Circuit

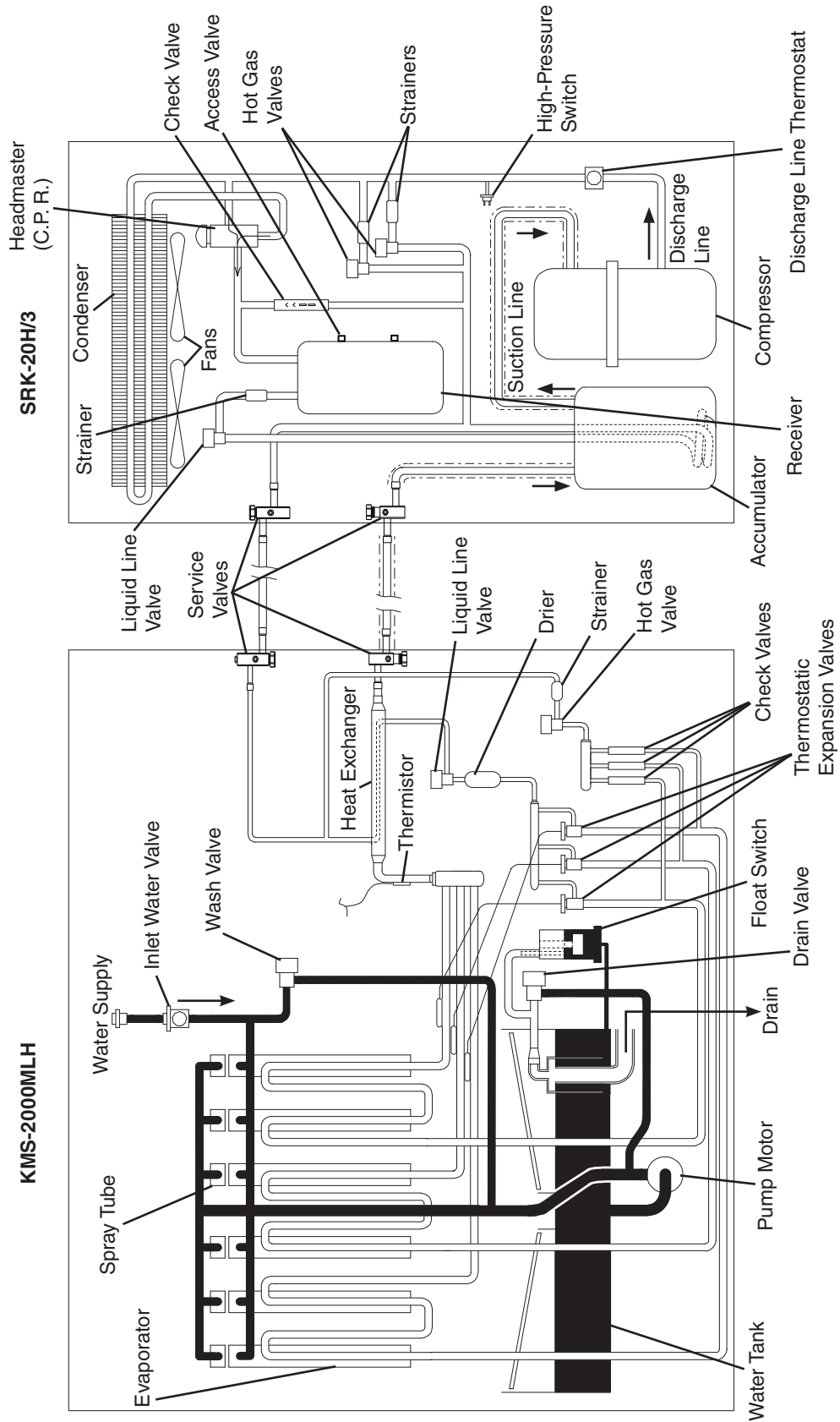

# B. Wiring Diagrams

## 1. KMS-2000MLH with SRK-20H

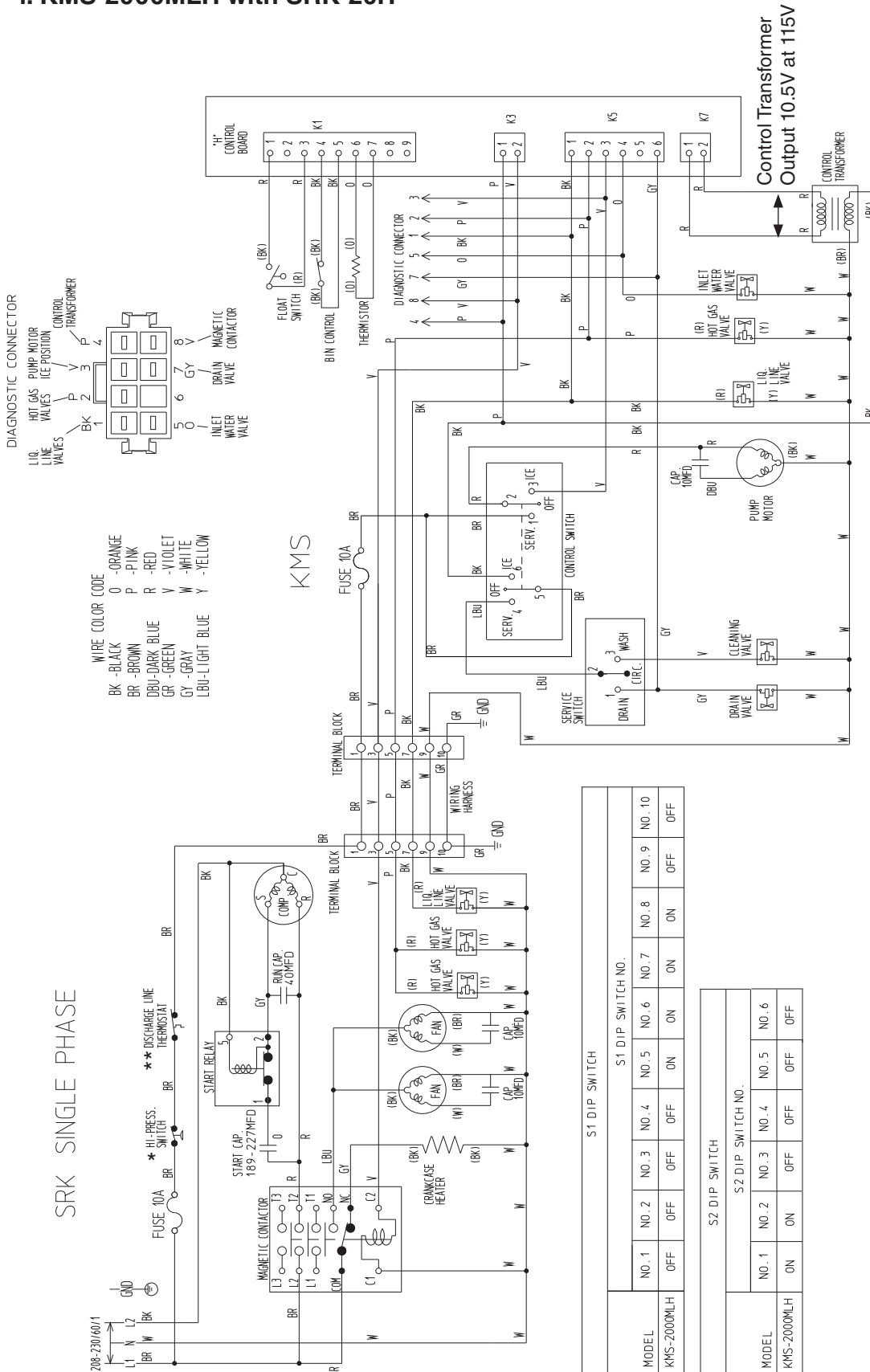

<b>** Discharge Line Thermostat Switch</b>	
Cut-out	266°F±9°F (130°C±5°C)
Cut-in	239°F±9°F (115°C±5°C)

<b>* High-Pressure Switch</b>	
Cut-out	426±22 PSIG
Cut-in	341±22 PSIG

MODEL	S1 DIP SWITCH NO.									
	NO.1	NO.2	NO.3	NO.4	NO.5	NO.6	NO.7	NO.8	NO.9	NO.10
KMS-2000MLH	OFF	OFF	OFF	OFF	ON	ON	ON	ON	OFF	OFF

MODEL	S2 DIP SWITCH NO.				
	NO.1	NO.2	NO.3	NO.4	NO.5
KMS-2000MLH	ON	ON	OFF	OFF	OFF



### 3. Wire Harness Connections

## KMS-SRK Wire Harness Connections

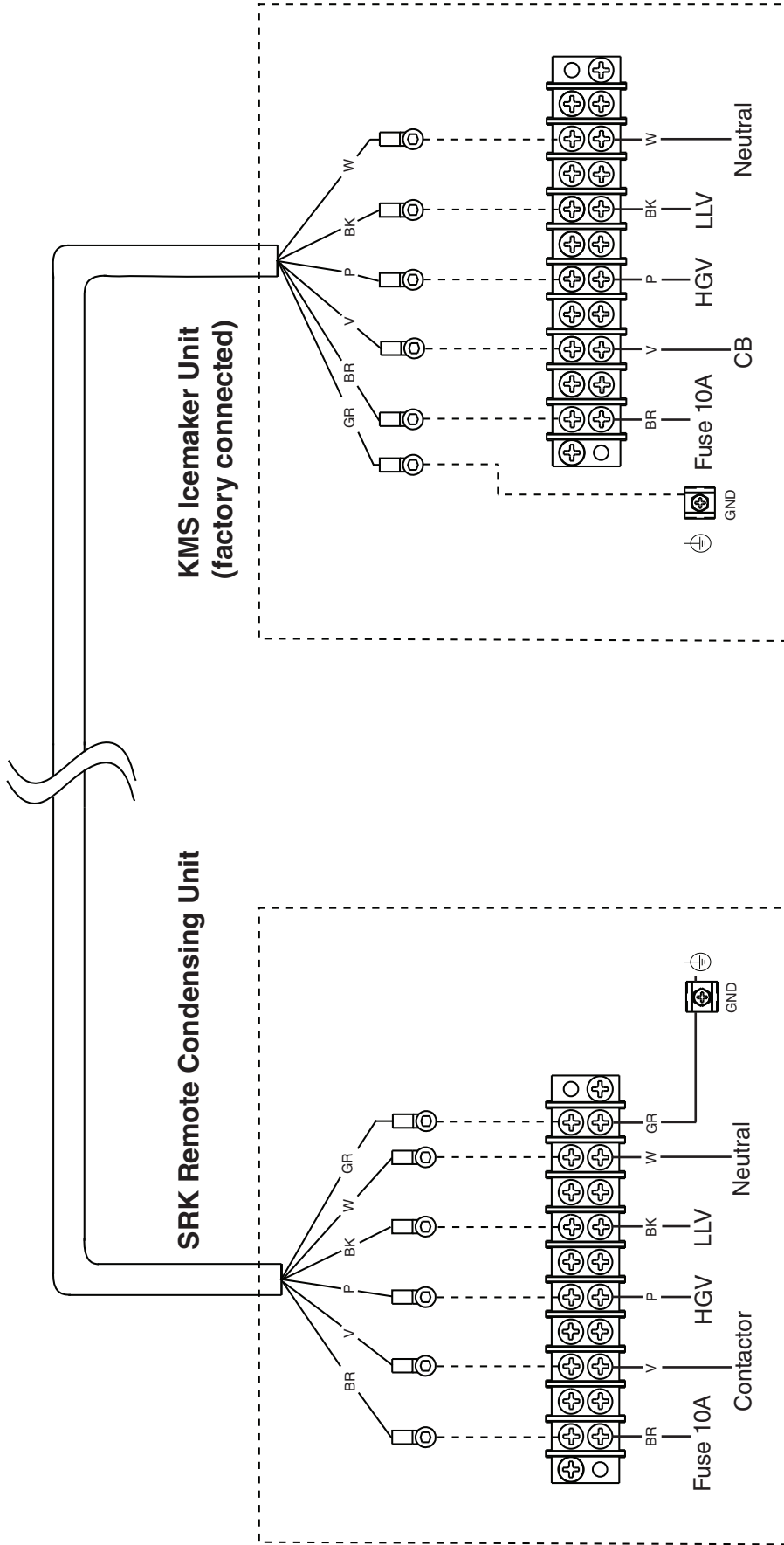

**Legend:**

- GND-ground
- HGV-hot gas valve
- CB-control board
- LLV-liquid line valve

**Wire Color Code:**

- BK-black
- BR-brown
- GR-green
- P-pink
- V-violet
- W-white

## C. Performance Data

### 1. KMS-2000MLH with SRK-20H

APPROXIMATE ICE PRODUCTION PER 24 HR.	AMBIENT TEMP. (°F/°C)	WATER TEMP. (°F/°C)					
		50/10		70/21		90/32	
	70/21	<b>1861</b>	<u>844</u>	1842	<u>835</u>	1722	<u>781</u>
	80/27	1846	<u>837</u>	1816	<u>824</u>	1645	<u>746</u>
	90/32	1842	<u>835</u>	<b>1795</b>	<u>814</u>	1643	<u>745</u>
lbs./day <u>kg./day</u>	100/38	1786	<u>810</u>	1759	<u>798</u>	1504	<u>682</u>
APPROXIMATE ELECTRIC CONSUMPTION	70/21	<b>3330</b>		3386		3408	
	80/27	3372		3459		3451	
	90/32	3386		<b>3520</b>		3525	
watts	100/38	3372		3521		3530	
APPROXIMATE WATER CONSUMPTION PER 24 HR.	70/21	<b>864</b>	<u>3.27</u>	726	<u>2.75</u>	634	<u>2.40</u>
	80/27		<u>0.00</u>	546	<u>2.06</u>	507	<u>1.92</u>
	90/32	726	<u>2.75</u>	<b>395</b>	<u>1.49</u>	332	<u>1.26</u>
gal./day <u>m<sup>3</sup>/day</u>	100/38	560	<u>2.12</u>	380	<u>1.44</u>	274	<u>1.04</u>
FREEZING CYCLE TIME	70/21	<b>19</b>		19		21	
	80/27	19		20		22	
	90/32	19		<b>21</b>		22	
min.	100/38	20		21		24	
HARVEST CYCLE TIME	70/21	<b>4.2</b>		3.7		3.4	
	80/27	3.8		3.0		2.9	
	90/32	3.7		<b>2.4</b>		2.2	
min.	100/38	3.1		2.4		2.0	
HEAD PRESSURE	70/21	<b>200</b>	<u>14.1</u>	212	<u>14.9</u>	224	<u>15.8</u>
	80/27	209	<u>14.7</u>	229	<u>16.1</u>	238	<u>16.7</u>
	90/32	212	<u>14.9</u>	<b>242</b>	<u>17.0</u>	253	<u>17.8</u>
PSIG <u>kg/cm<sup>2</sup>G</u>	100/38	213	<u>15.0</u>	245	<u>17.2</u>	263	<u>18.5</u>
SUCTION PRESSURE	70/21	<b>41</b>	<u>2.9</u>	43	<u>3.0</u>	44	<u>3.1</u>
	80/27	42	<u>3.0</u>	45	<u>3.2</u>	46	<u>3.3</u>
	90/32	43	<u>3.0</u>	<b>47</b>	<u>3.3</u>	49	<u>3.4</u>
PSIG <u>kg/cm<sup>2</sup>G</u>	100/38	43	<u>3.0</u>	47	<u>3.3</u>	50	<u>3.5</u>

TOTAL HEAT OF REJECTION FROM CONDENSER 37,300 BTU/h [AT 90°F (32°C) / WT 70°F (21°C)]

CONDENSER VOLUME 964 CU. IN (SRK-20H)

**Note:**

1. Pressure data is recorded at 5 minutes into freezing cycle. The data not in bold should be used for reference only.
2. We reserve the right to make changes in specifications and design without prior notice.

## 2. KMS-2000MLH with SRK-20H3

APPROXIMATE ICE PRODUCTION PER 24 HR.	AMBIENT TEMP. (°F/°C)	WATER TEMP. (°F/°C)					
		50/10		70/21		90/32	
	70/21	<b>1910</b>	<u>866</u>	1850	<u>839</u>	1767	<u>801</u>
	80/27	1864	<u>846</u>	1772	<u>804</u>	1687	<u>765</u>
	90/32	1850	<u>839</u>	<b>1706</b>	<u>774</u>	1620	<u>735</u>
lb./day <u>kg./day</u>	100/38	1833	<u>831</u>	1686	<u>765</u>	1541	<u>699</u>
APPROXIMATE ELECTRIC CONSUMPTION	70/21	<b>3290</b>		3296		3379	
	80/27	3294		3304		3429	
	90/32	3296		<b>3310</b>		3419	
watts	100/38	3338		3336		3520	
APPROXIMATE WATER CONSUMPTION PER 24 HR.	70/21	<b>917</b>	<u>3.47</u>	765	<u>2.89</u>	664	<u>2.51</u>
	80/27	801	<u>3.03</u>	564	<u>2.14</u>	524	<u>1.98</u>
	90/32	765	<u>2.89</u>	<b>397</b>	<u>1.50</u>	329	<u>1.25</u>
gal./day <u>m<sup>3</sup>/day</u>	100/38	581	<u>2.20</u>	382	<u>1.44</u>	267	<u>1.01</u>
FREEZING CYCLE TIME	70/21	<b>18</b>		19		20	
	80/27	19		20		21	
	90/32	19		<b>21</b>		22	
min.	100/38	19		21		24	
HARVEST CYCLE TIME	70/21	<b>4.2</b>		3.7		3.3	
	80/27	3.8		3.0		2.9	
	90/32	3.7		<b>2.4</b>		2.2	
min.	100/38	3.0		2.4		2.0	
HEAD PRESSURE	70/21	<b>203</b>	<u>14.3</u>	214	<u>15.1</u>	233	<u>16.4</u>
	80/27	211	<u>14.9</u>	229	<u>16.1</u>	250	<u>17.5</u>
	90/32	214	<u>15.1</u>	<b>241</b>	<u>16.9</u>	261	<u>18.4</u>
PSIG <u>kg/cm<sup>2</sup>G</u>	100/38	219	<u>15.4</u>	246	<u>17.3</u>	280	<u>19.7</u>
SUCTION PRESSURE	70/21	<b>40</b>	<u>2.8</u>	41	<u>2.9</u>	44	<u>3.1</u>
	80/27	41	<u>2.9</u>	43	<u>3.0</u>	46	<u>3.2</u>
	90/32	41	<u>2.9</u>	<b>44</b>	<u>3.1</u>	47	<u>3.3</u>
PSIG <u>kg/cm<sup>2</sup>G</u>	100/38	42	<u>3.0</u>	45	<u>3.1</u>	50	<u>3.5</u>

TOTAL HEAT OF REJECTION FROM CONDENSER

36,000 BTU/h [AT 90°F (32°C) / WT 70°F (21°C)]

CONDENSER VOLUME

964 CU. IN (SRK-20H3)

### Note:

1. Pressure data is recorded at 5 minutes into freezing cycle. The data not in bold should be used for reference only.
2. We reserve the right to make changes in specifications and design without prior notice.

## IV. Service Diagnosis

### ⚠ WARNING

1. This unit should be diagnosed and repaired only by qualified service personnel to reduce the risk of death, electric shock, serious injury, or fire.
2. Risk of electric shock. Use extreme caution and exercise safe electrical practices.
3. Moving parts (e.g., fan blade) can crush and cut. Keep hands clear.
4. **CHOKING HAZARD:** Ensure all components, fasteners, and thumbscrews are securely in place after the unit is serviced. Make sure that none have fallen into the dispenser unit/storage bin.
5. Make sure all food zones in the icemaker and dispenser unit/storage bin are clean after the unit is serviced. For cleaning procedures, see "VI. Cleaning and Maintenance."

### A. Diagnostic Procedure

The diagnostic procedure is basically a sequence check that allows you to diagnose the electrical system and components. Before proceeding, check for correct installation, proper voltage per unit nameplate, and adequate water supply (minimum of 10 PSIG, maximum of 113 PSIG). Check that the 115VAC 10A fuses located in the SRK and KMS are good and that the wire harness is connected correctly. If the icemaker is in alarm, see "IV.B. Control Board Check" or "II.C.2. LED Lights and Audible Alarm Safeties." Check the dip switch settings to assure that S1 dip switch 7 through 10 and S2 dip switch 1 through 6 are in the factory default position. S1 dip switch 1 through 6 are cleaning adjustments and the settings are flexible. For factory default settings, see "II.C.3.a) Default Dip Switch Settings." As you go through the procedure, check to assure the components energize and de-energize correctly. If not, those components and controls are suspect. To check voltages coming from CB, a diagnostic connector is provided. See Fig. 1. When checking high-voltage, always choose a neutral (W wire) to establish a good neutral connection.

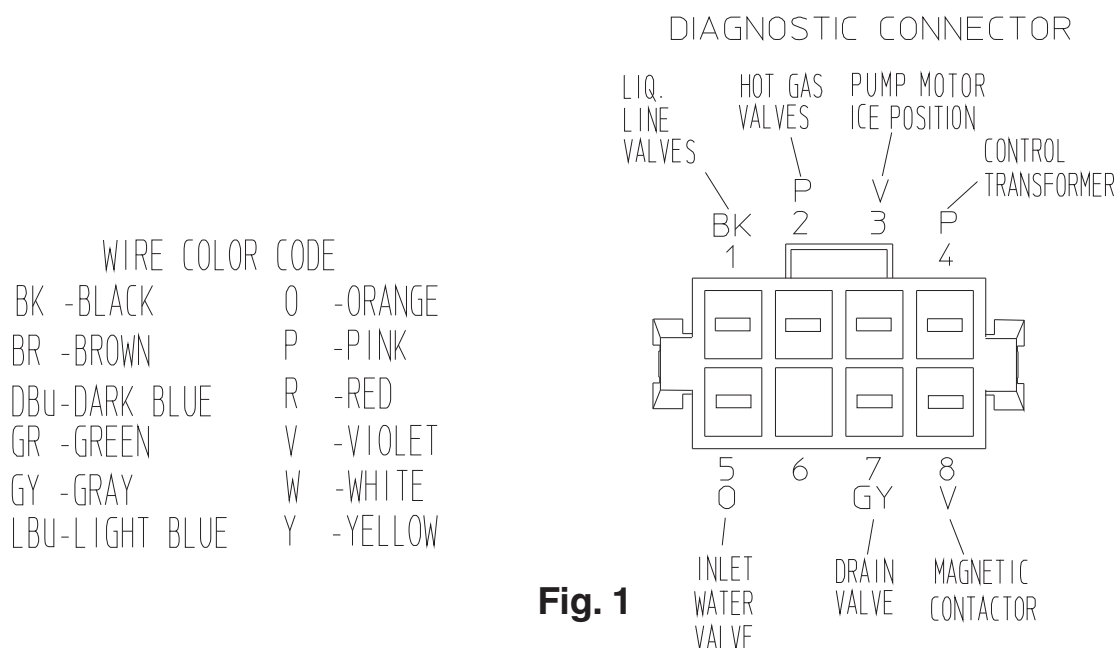

**Fig. 1**



- 1) Turn off the power supply, then access the control box. Clear any ice from BC.
- 2) Turn on the power supply, then move the control switch to the "ICE" position. A 5-second delay occurs. CB red "POWER OK" LED turns on. If CB red "POWER OK" LED is flashing (indicating a full bin), clear ice away from BC. If bin is empty, see "IV.C.1. Bin Control Check."
- 3) **1-Minute Fill Cycle – LED 8 is on.** WV energizes. After 1 minute, CB checks for a closed F/S. If F/S is closed, harvest cycle begins. If closed, continue to step 4. If open, WV remains energized through additional 1-minute fill cycles until water fills the water tank and closes F/S (low water safety). **Diagnosis:** Confirm that water is filling the water tank. If not, check that the water supply shut-off valve is open and WV screen and any external filters are clear. If WV does not energize (LED 8 on), check the diagnostic connector pin #5 (O wire) to a neutral (W wire) for 115VAC. If no voltage is present, replace CB. If voltage is present, check WV connections and solenoid continuity. If unit fails to start harvest, check for open F/S or bad 1-minute timer in CB. See "IV.D. Float Switch Check and Cleaning."
- 4) **Initial Harvest Cycle – LEDs 5, 6, and 8 are on.** WV remains energized. Comp, FMRs, and HGVs energize. CB monitors the warming of the evaporator via the thermistor located on the suction line. When the thermistor reaches 48°F (9°C), CB reads 3.9 kΩ from the thermistor and turns harvest termination over to the harvest timer (S1 dip switch 1 & 2). For details, see "II.C.3.b) Harvest Timer (S1 dip switch 1 & 2)." The pump-out timer (S1 dip switch 3 & 4) acts in place of the harvest timer during cycles with a pump-out. For details, see "II.C.3.c) Pump-Out Timer (S1 dip switch 3 & 4)." WV is energized during harvest for a maximum of 6 minutes or the length of harvest minus 50 seconds (harvest pump timer (S1 dip switch 7 & 8)), whichever is shorter. 50 seconds before the harvest timer terminates, LED 8 turns off and WV de-energizes. **Harvest Pump Timer: LEDs 5, 6, and 7 are on.** LED 7 turns on and PM energizes for the last 50 seconds of harvest. **NOTICE! S1 dip switch 7 & 8 must remain in the factory default position of 7 on and 8 on. Otherwise, PM will not energize for 50 seconds at the end of harvest.** Comp, FMRs, and HGVs remain energized. When the harvest timer terminates, the harvest cycle is complete. CB checks the position of F/S and proceeds to the next cycle if it is closed or calls for a 1-minute fill cycle if it is open. The minimum total time allowed by CB for a complete harvest cycle is 2 minutes. **Diagnosis:** Check that Comp, FMRs, and HGVs energize. Average initial harvest cycle at factory setting is 2 to 3 minutes. 1.5 minutes after initial harvest begins, touch Comp discharge line. Is it hot? If not, check that Comp is energized and HGVs are energized and open. If not, check the diagnostic connector pin #2 (P wire) to a neutral (W wire) for 115VAC. Check that LLVs are de-energized and closed. Confirm proper unit pressures. Place a thermometer on the suction line next to the thermistor. If 48°F (9°C) has been reached, but WV does not de-energize 50 seconds before the harvest timer should terminate, check the thermistor. See "IV.E. Thermistor Check." If the thermistor reading is in the proper range and CB fails to terminate the harvest cycle and initiate the freeze cycle, replace CB.

**Harvest Pump Timer:** PM energizes (LED 7 on) last 50 seconds of harvest. If not, make sure CB S1 dip switch 7 and 8 are in the factory default position. Check diagnostic connector pin #3 (V wire) to a neutral (W wire) for 115VAC. If 115VAC is present, check PM windings and capacitor. If 115VAC is not present, replace CB. If 1-minute fill cycle starts after harvest, see "IV.D. Float Switch Check and Cleaning."

- 5) **Freeze Cycle – LEDs 5 & 7 are on.** Comp, FMRs, and PM remain energized. LLVs energize, HGVs de-energize. CB monitors the cooling of the evaporator via the thermistor located on the suction line. When the temperature drops to 36°F (2°C), CB reads 5.5 kΩ from the thermistor and starts the 5-minute short cycle protection timer. CB does not monitor F/S until the 5-minute short cycle protection timer terminates. After the 5-minute short cycle protection timer terminates, CB 1-minute default refill timer starts (LED 9 is on during CB 1-minute default refill). The KMS-2000MLH is not wired for the 1-minute default refill. When CB 1-minute default refill timer terminates, CB turns freeze termination over to F/S. As ice builds on the evaporator, the water level in the water tank lowers. The freeze cycle continues until F/S is open for 15 continuous seconds.

**Anti-Slush Control: LEDs 5 is on.** Comp, FMRs, and LLVs remain energized. PM de-energizes for 10 seconds. CB monitors the cooling of the evaporator via the thermistor located on the suction line. When the temperature drops to 34°F (1°C), CB reads 5.8 kΩ from the thermistor, then LED 7 turns off and PM de-energizes for 10 seconds. **NOTICE! Do not adjust S2 dip switch 6 out of the factory default position on this model.** This setting helps prevent slushing during the freeze cycle. **Diagnosis:** Check that Comp, FMRs, and PM remain energized. Confirm that evaporator temperature drops. If not, confirm that LLVs are energized and open (LED 6 off). If not, check the diagnostic connector pin #1 (BK wire) to a neutral (W wire) for 115VAC. Next, check that WV and HGVs are de-energized and closed (not leaking by). Confirm proper unit pressures and TXV operation, check for an inoperative HM or an inefficient Comp.

**Quick Check:** Once the freeze cycle begins, disconnect the thermistor and F/S from the control box. LED 5 turns off and PM de-energizes for 10 seconds. If not, confirm that S2 dip switches 5 and 6 are in the factory default position. If they are in their correct positions, and PM does not de-energize and energize 10 seconds later, replace CB. CB 5-minute short cycle protection timer starts as soon as the thermistor is disconnected. CB does not monitor F/S until the 5-minute short cycle protection timer terminates. When the 5-minute short cycle protection timer terminates, CB monitors UF/S for a continuous 15 second open condition. With no UF/S on the KMS-2000MLH, CB 1-minute default refill timer starts (LED 9 is on during CB 1-minute default refill). The KMS-2000MLH is not wired for the CB 1-minute default refill. After CB 1-minute default refill timer terminates, CB monitors LF/S for a continuous 15-second open condition. When LF/S is open continuously for 15 seconds, CB terminates the freeze cycle and initiates the next cycle. If not, replace CB. For F/S check, see "IV.D. Float Switch Check and Cleaning." To check the thermistor, see "IV.E. Thermistor Check."

Note: Normal freeze cycle will last 30 to 35 minutes depending on model and conditions. Cycle times and pressures should follow performance data provided in this manual. See "III.C. Performance Data."

- 6) **Pump-Out Cycle – (10 second pump-out) – LEDs 5, 6, 4, and 7 are on.** Comp and FMRs remain energized. HGVs energize. LLVs de-energize. PM de-energizes for 2 seconds, then PM and DV energize for 10 seconds.  
**Diagnosis: PM Operation:** If PM does not energize, confirm S2 dip switch 1 is in the factory default position. See "II.C.3.g) Pump-Out/Drain Selector (S2 dip switch 1). Check diagnostic connector pin #3 (V wire) to a neutral (W wire) for 115VAC. If LED 7 is on and 115VAC is not present, replace CB. If 115VAC is present and PM is still not energized, check control switch continuity between terminal #3 (V wire) and terminal #2 (R wire). If closed, check PM windings and capacitor. **DV Operation:** If PM energizes and water does not pump out, remove DV housing and check/clean DV assembly. Make sure the drain line is not clogged. Next, check the diagnostic connector pin #7 (GY wire) to a neutral (W wire) for 115VAC. If 115VAC is not present, replace CB. If 115VAC is present, check continuity on DV coil.
- 7) **Normal Harvest Cycle** – Same as the initial harvest cycle. Return to step 4.  
 Note: Unit continues to cycle until BC is satisfied or power is switched off. The unit always restarts at the 1-minute fill cycle.
- 8) **Shutdown – LEDs 4 and 7 are on:** When BC is activated (BC open), CB red "POWER OK" LED flashes. There is a delay before the shutdown sequence begins. The delay varies depending on the cycle the icemaker is in at the time of activation. For details, see the table below.

Cycle at Bin Control Activation	Delay Before Shutdown Sequence Begins
Fill Cycle	15 seconds
Harvest Cycle	15 seconds after the next freeze cycle starts
Freeze Cycle	15 seconds if BC is activated between the beginning of freeze and termination of the 5-minute short cycle protection timer (timer starts when the thermistor temperature drops to 36°F (2°C) (5.5 kΩ or more)). After this time, the unit will not shut down until the next harvest cycle is complete.

After the shutdown delay, all components de-energize. 2 seconds later, DV and PM energize. PM takes water from the water tank and pumps it through DV and down the drain. **NOTICE! Do not adjust S2 dip switch 1 out of the factory default position on this model. This dip switch must be left in the factory default position or this unit will not operate correctly.** For details, see "II.C.3.g) Pump-Out/Drain Selector (S2 dip switch 1)." The water tank drains for a maximum of 5 minutes or until F/S opens. DV and PM then de-energize. When BC closes again calling for ice, the unit starts at the 1-minute fill cycle. There is a 90-second minimum off time before the icemaker can restart. **Diagnostics:** Disconnect BC from the control box. CB red "POWER OK" LED begins flashing. If not, replace CB. Next, check for continuity across BC. BC should be closed when actuator paddle is not engaged. Press the actuator paddle, check BC continuity. BC should be open when actuator paddle is engaged. For further details, see "IV.C. Bin Control Check and Cleaning."

Legend: **BC**–bin control; **CB**–control board; **Comp**–compressor; **DV**–drain valve; **FMRs**–fan motors-remote; **F/S**–float switch; **HGVs**–hot gas valves; **HM**–headmaster (C.P.R.); **LF/S**–lower float switch; **LLVs**–liquid line valves; **PM**–pump motor; **TXVs**–thermostatic expansion valves; **UF/S**–upper float switch; **WV**–inlet water valve

## B. Control Board Check

Before replacing a control board that does not show a visible defect and that you suspect is bad, always conduct the following check procedure. This procedure will help you verify your diagnosis. Always choose a neutral (W wire) to establish a good neutral connection when checking voltages.

Alarm Reset: If CB is in alarm (beeping), press the "ALARM RESET" button on CB while CB is beeping. **WARNING! Risk of electric shock. Care should be taken not to touch live terminals.** Once reset, the unit starts at the 1-minute fill cycle. For audible alarm information, see "II.C.2. LED Lights and Audible Alarm Safeties."

- 1) Check the dip switch settings to assure that S1 dip switch 7 through 10, and S2 dip switch 1 through 6 are in the factory default position. S1 dip switch 1 through 6 are cleaning adjustments and the settings are flexible. For factory default settings, see "II.C.3.a) Default Dip Switch Settings."
- 2) The KMS-2000MLH utilizes CB version 2.5. See the label located on CB for CB version or follow the steps below to determine CB version.
  - a) With the control switch in the "OFF" position, press and hold the "OUTPUT TEST" and "ALARM RESET" buttons.
  - b) Continue holding the buttons and move the control switch to the "ICE" position.
  - c) A tone sounds indicating CB is in "test mode". While continuing to hold down the "OUTPUT TEST" button, release the "ALARM RESET" button.
  - d) As long as the "OUTPUT TEST" button is held down, CB indicates the version using beeps. The first set of beeps indicates the major version level and the second set of beeps indicates the minor version level. Example: 2 beeps followed by 5 beeps = version 2.5
  - e) Move the control switch to the "OFF" position to exit "test mode".
- 3) Clear any ice away from BC. Move the control switch to the "ICE" position. If CB red "POWER OK" LED turns on, control voltage is good, continue to step 4. If CB red "POWER OK" LED is off, check CT secondary circuit. CT output is 10.5VAC at 115VAC primary input. If CT secondary circuit has proper voltage and CB red "POWER OK" LED is off, replace CB. If CT secondary circuit does not have proper voltage, check CT primary circuit. Check for 115VAC at the diagnostic connector pin #4 (P wire) to a neutral (W wire). For additional checks, see "IV.F.1. No Ice Production." If CB red "POWER OK" LED is flashing, confirm BC connections, clear any ice from BC actuator paddle. If CB red "POWER OK" is still flashing and no BC issues are present, replace CB.
- 4) The "OUTPUT TEST" button provides a relay sequence test. Move the control switch to the "OFF" position. While pressing the "OUTPUT TEST" button, move the control switch back to the "ICE" position. The correct LED lighting sequence is 5, 6, 7, 8, 9, 4. Note that the order of the LEDs from the outer edge of CB is 5, 6, 8, 9, 4, 7. Components (e.g., Comp) cycle during the test. Each LED stays on for 5 seconds. LED 5 stays on while LED 6 is on. CB red "POWER OK" LED flashes once when the first relay LED turns on, twice when the second relay LED turns on, and adds one flash for each LED thereafter. A beep also sounds as each LED turns on. Following the test, the icemaker resumes operation. If the LEDs do not turn on as described above, replace CB.

- 5) Utilize the diagnostic connector (Fig. 1.) to verify output voltage from CB to components. With the unit in the cycle to be tested, check CB output voltage from the corresponding terminal on the diagnostic connector to a neutral (W wire). If output voltage is not present and the appropriate LED is on, replace CB.

Legend: **BC**—bin control; **CB**—control board; **Comp**—compressor; **CT**—control transformer.

### C. Bin Control Check and Cleaning

This unit uses a BC with a lever-actuated proximity switch to control the ice level in the storage bin. No adjustment is required. When calling for ice, BC proximity switch is closed (CB red "POWER OK" LED on). When BC actuator paddle is engaged, BC proximity switch is open (CB red "POWER OK" LED flashing) and CB shuts down the unit according to the chart below.

Cycle at Bin Control Activation	Delay Before Shutdown Sequence Begins
Fill Cycle	15 seconds
Harvest Cycle	15 seconds after the next freeze cycle starts
Freeze Cycle	15 seconds if BC is activated between the beginning of freeze and termination of the 5-minute short cycle protection timer (timer starts when the thermistor temperature drops to 36°F (2°C) (5.5 kΩ or more)). After this time, the unit will not shut down until the next harvest cycle is complete.

#### ⚠ WARNING

**CHOKING HAZARD:** Ensure all components, fasteners, and thumbscrews are securely in place after the unit is serviced. Make sure that none have fallen into the dispenser unit/storage bin.

#### 1. Bin Control Check

To check BC, follow the steps below.

- 1) Turn off the power supply.
- 2) Remove the front panel, then move the control switch to the "OFF" position.
- 3) Clear any ice away from BC.
- 4) Remove the control box cover, then disconnect CB K1 wire harness connector from the control board. See "II.C.1. Control Board Layout."
- 5) Check for continuity across CB K1 wire harness connector pins #4 and #5 (BK wires). When the actuator paddle is not engaged, BC switch is closed. If open, check that the actuator paddle is not sticking and that the K1 wire harness BC connector is properly secured. Clean BC if necessary. See "IV.C.2. Bin Control Cleaning." If BC switch still reads open, replace BC.
- 6) Press the actuator paddle, check for continuity across CB K1 wire harness connector pins #4 and #5 (BK wires). When the actuator paddle is engaged, the BC switch is open. If closed, check that the actuator paddle is not restricted. Clean if necessary. See "IV.C.2. Bin Control Cleaning." If BC switch still reads closed, replace BC.
- 7) Reconnect CB K1 wire harness connector to the control board.
- 8) Turn on the power supply, then move the control switch to the "ICE" position.
- 9) Check that CB red "POWER OK" LED is on and not flashing.



- 10) Allow the unit to cycle on. During the 1-minute fill cycle, press the actuator in and hold it in for 15 seconds. Check that CB red "POWER OK" LED flashes, and after the actuator is held in for 15 seconds, PM and DV energize (maximum time 5 minutes) and the water tank drains. After the water tank drains and F/S opens, the unit shuts down. If the water tank does not drain, check for a clogged drain line, defective DV or PM. If F/S fails to open after the water tank drains, see "IV.D. Float Switch Check and Cleaning." If F/S checks out and the unit will not shut down, replace CB.
- 11) Replace the control box cover and front panel in their correct positions.
- 12) Turn on the power supply to start the automatic icemaking process.

Legend: **BC**—bin control, **CB**—control board, **DV**—drain valve; **F/S**—float switch; **PM**—pump motor

## 2. Bin Control Cleaning

Scale may build up on BC. Scale can cause the actuator paddle and magnet to stick. In this case, BC should be cleaned.

- 1) Turn off the power supply.
- 2) Remove the front panel, then move the control switch to the "OFF" position.
- 3) Clear any ice away from BC.
- 4) Remove the top and right side panels.
- 5) Disconnect CB K1 wire harness BC connector from the BC cable connector, then remove BC from the unit.
- 6) Remove the actuator paddle from the switch mount. See Fig. 2.
- 7) Wipe down BC with a mixture of 1 part Hoshizaki "Scale Away" and 25 parts warm water. Rinse the parts thoroughly with clean water.
- 8) Reassemble BC and replace it in its correct position.  
Note: If the magnet was removed for cleaning, be sure to replace it in its correct position.
- 9) Reconnect BC cable connector to CB K1 wire harness BC connector.
- 10) Move the control switch to the "ICE" position.
- 11) Replace the right side, top, and front panels in their correct positions.
- 12) Turn on the power supply to start the automatic icemaking process.

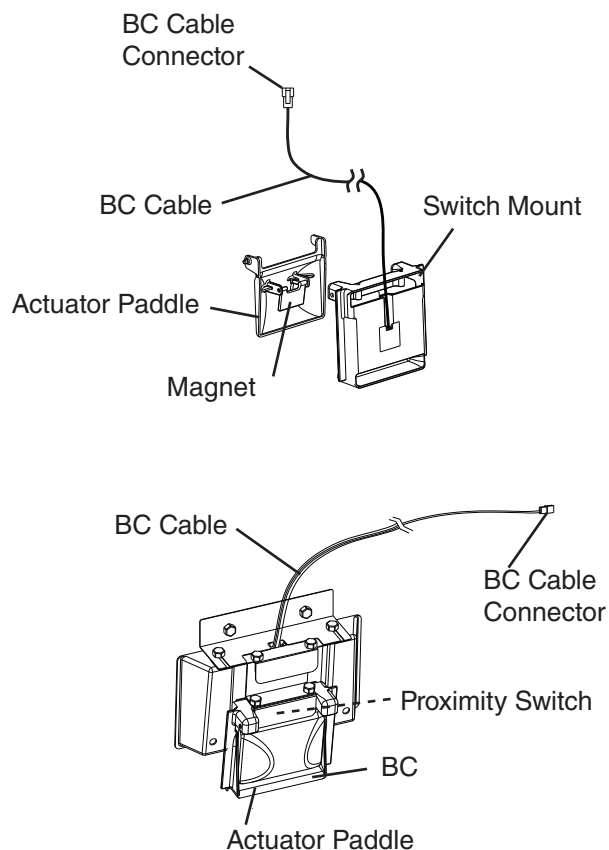

**Fig. 2**

Legend: **BC**—bin control; **CB**—control board

## **D. Float Switch Check and Cleaning**

A single F/S is used to determine that there is sufficient water in the water tank after the 1-minute fill cycle and after each harvest cycle. The F/S is also used to determine that the appropriate volume of water has been converted into ice before switching out of the freeze cycle. No adjustment is required.

### **1. Float Switch Check**

To check F/S, follow the steps below.

- 1) Turn off the power supply.
- 2) Remove the front panel and move the control switch to the "SERVICE" position. Move the service switch to the "DRAIN" position.
- 3) Turn on the power supply.
- 4) Allow the water to drain from the water tank, then move the control switch to the "OFF" position.
- 5) Turn off the power supply.
- 6) Remove the control box cover, then disconnect CB K1 wire harness connector from the control board. See "II.C.1. Control Board Layout."
- 7) Check for continuity across CB K1 wire harness connector pins #1 and #3 (R wires). With the water tank empty, the float switch is open. If open, continue to step 8. If closed, follow the steps in "IV.D.2. Float Switch Cleaning." After cleaning the float switch, check it again. Replace if necessary.
- 8) Reconnect CB K1 wire harness connector to the control board, then replace the control box cover in its correct position.
- 9) Move the control switch to the "ICE" position. Replace the front panel in its correct position, then turn on the power supply. After 1 minute, the 1-minute fill cycle should end and the initial harvest cycle should begin. If the initial harvest cycle begins, F/S is good and the check is complete. If the initial harvest cycle does not begin, continue to step 10.
- 10) Turn off the power supply.
- 11) Remove the front panel. Move the control switch to "OFF" position.
- 12) Remove the control box cover, then disconnect CB K1 wire harness connector from the control board.
- 13) Check for continuity across CB K1 wire harness connector pins #1 and #3 (R wires). With the water tank full, F/S is closed. If F/S is closed and the icemaker will not switch from the 1-minute fill cycle to the initial harvest cycle, replace CB.

If F/S is open, confirm that the CB K1 wire harness F/S connector has a good connection with the F/S cable connector and that the water tank is full. If the water tank is not full, check the water supply, water filters, and WV. If the water tank is full, follow the steps in "IV.D.2. Float Switch Cleaning." After cleaning F/S, check it again. Replace if necessary.

## 2. Float Switch Cleaning

Depending on local water conditions, scale may build up on F/S. Scale can cause F/S to stick. In this case, F/S should be cleaned.

- 1) Turn off the power supply.
- 2) Remove the front panel, then move the control switch to the "SERVICE" position. Move the service switch to the "DRAIN" position. Replace the front panel in its correct position.
- 3) Turn on the power supply.
- 4) Allow the water to drain from the water tank.
- 5) Turn off the power supply. Remove the front panel, then move the control switch to the "OFF" position.
- 6) Disconnect F/S cable connector from CB K1 wire harness F/S connector located on the control box.
- 7) Remove the top and right side panels.
- 8) Disconnect the flush tube from the top of F/S housing, then remove F/S assembly from the mounting bracket and remove the rubber boot from the bottom of F/S assembly.
- 9) Remove the retainer rod from the bottom of F/S assembly, then remove the float. Be careful not to bend the retainer rod excessively when removing it.
- 10) Wipe down F/S assembly's housing, shaft, float, and retainer rod with a mixture of 1 part Hoshizaki "Scale Away" and 25 parts warm water. Clean the inside of the rubber boot and hose with cleaning solution. Rinse the parts thoroughly with clean water.
- 11) Reassemble F/S assembly and replace it and the rubber boot in their correct positions. Reconnect the flush tube.
- 12) Reconnect F/S cable connector to CB K1 wire harness F/S connector located on the control box.
- 13) Replace the right side and top panels in their correct positions.
- 14) Move the control switch to the "ICE" position.
- 15) Replace the front panel in its correct position.
- 16) Turn on the power supply to start the automatic icemaking process.

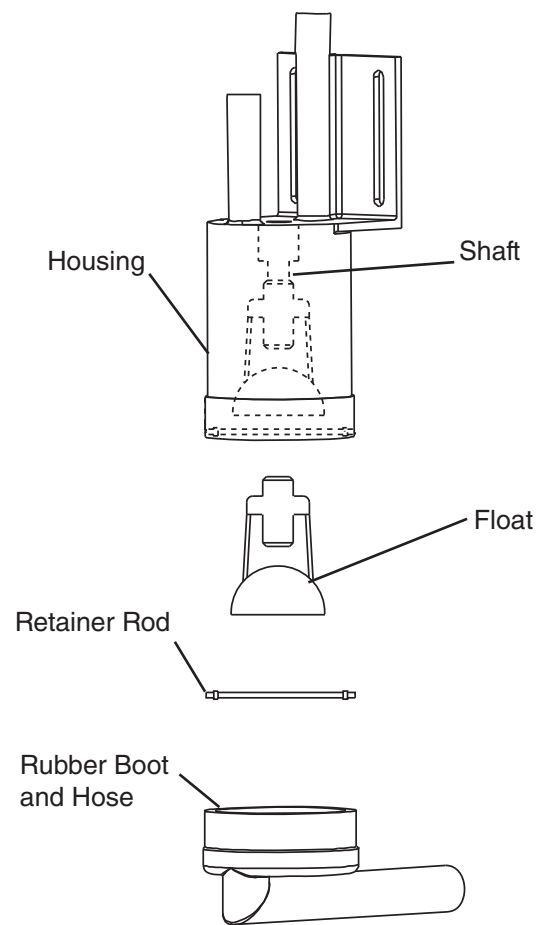

**Fig. 3**

Legend: **CB**—control board; **F/S**—float switch; **WV**—inlet water valve



## E. Thermistor Check

To check thermistor resistance, follow the steps below.

- 1) Turn off the power supply.
- 2) Remove the front panel, then move the control switch to the "OFF" position.
- 3) Remove the top and right side panels.
- 4) Remove the thermistor from the suction line.
- 5) Immerse the thermistor sensor portion in a glass containing ice and water for 2 or 3 minutes.
- 6) Remove the control box cover, then disconnect CB K1 wire harness connector from CB. See "II.C.1. Control Board Layout."
- 7) Check the resistance between CB K1 wire harness connector pins #6 and #7 (O wires). Normal range is 4.7 to 6.2 k $\Omega$ . If open, confirm that CB K1 wire harness thermistor connector has a good connection with the thermistor cable connector located on the control box. If outside the normal range, replace the thermistor. See "V.B. Important Notes for Component Replacement." If within the normal range, continue to step 8.
- 8) Replace the thermistor in its correct position. See "V.B. Important Notes for Component Replacement."
- 9) Reconnect CB K1 wire harness connector to CB, then replace the control box cover in its correct position.
- 10) Move the control switch to the "ICE" position. Replace the right side, top, and front panels in their correct positions.
- 11) Turn on the power supply.
- 12) Once the harvest cycle starts (Comp energizes), begin timing the harvest cycle.
- 13) The harvest timer and harvest cycle should terminate within 2 to 5 minutes. If the harvest cycle does not terminate within 2 to 5 minutes, replace CB.

Legend: **CB**—control board; **Comp**—compressor

## F. Diagnostic Charts

Before consulting the diagnostic charts, check for correct installation, proper voltage per unit nameplate, and adequate water supply. Check CB using the steps in "IV.B. Control Board Check." Check the dip switch settings to assure that S1 dip switch 7 through 10 and S2 dip switch 1 through 6 are in the factory default position. S1 dip switch 1 through 6 are cleaning adjustments and the settings are flexible. For factory default settings, see "II.C.3.a) Default Dip Switch Settings."

### 1. No Ice Production

No Ice Production - Possible Cause	
1. Power Supply	a) Off, blown fuse, or tripped breaker.
	b) Not within specifications.
2. Main Transformer (208-230V/115V) (3 Phase Only)	a) Voltage tap switch not set to proper voltage.
	b) Coil winding open or shorted.
3. Water Supply	a) Water supply off or improper water pressure.
	b) External water filters clogged.
4. Fuse (SRK Control Box)	a) Blown.
5. High-Pressure Switch (SRK)	a) Dirty condenser.
	b) Condensing unit fans not operating.
	c) Headmaster (C.P.R.) open.
	d) Refrigerant overcharged.
	e) Bad contacts.
	f) Refrigerant lines or components plugged.
6. Discharge Line Thermostat (SRK)	a) Ambient temperature too warm.
	b) Compressor or compressor components faulty.
	c) Defective.
	d) Hot gas valves open.
	e) Dirty condenser.
	f) Condensing unit fans not operating.
7. Wire Harness (From SRK to KMS)	a) Disconnected or loose connection.
8. Fuse (KMS Control Box)	a) Blown.
9. Control Switch	a) In "SERVICE" or "OFF" position.
	b) Bad contacts.
10. Control Transformer (115V/10.5V)	a) Coil winding open or shorted.
11. Control Board See "IV.B. Control Board Check"	a) In alarm.
	b) BC open, CB red "POWER OK" LED flashing (bin full).
	c) Defective.
12. Bin Control See "IV.C. Bin Control Check and Cleaning"	a) Tripped with bin filled with ice.
	b) Actuator does not move freely.
	c) Defective.
13. Inlet Water Valve	a) Screen or orifice clogged.
	b) Coil winding open.
	c) Open in freeze cycle.
14. Drain Valve	a) Dirty, leaking by.

<b>No Ice Production - Possible Cause</b>	
15. Float Switch See "IV.D. Float Switch Check and Cleaning"	a) Float does not move freely.
	b) Defective.
16. Compressor	a) Magnetic contactor contacts bad or coil winding open.
	b) Start capacitor or run capacitor defective (single phase only).
	c) Internal protector open.
	d) Start relay contacts bad or coil winding open (single phase only).
	e) Compressor defective.
17. Hot Gas Valves (KMS & SRK)	a) Closed in harvest cycle.
	b) Open in freeze cycle.
18. Thermistor See "IV.E. Thermistor Check"	a) Loose, disconnected, or defective.
19. Pump Motor	a) Motor winding open.
	b) Bearing worn out or locked rotor.
	c) Defective capacitor.
	d) Mechanical seal worn out.
20. Thermostatic Expansion Valves	a) Bulb loose.
	b) Operating erratically.
21. Liquid Line Valves (KMS & SRK)	a) Closed in freeze cycle.
	b) Open in harvest cycle.
22. Remote Fan Motors (SRK)	a) Motor winding open.
	b) Bearing worn out or locked rotor.
	c) Defective capacitor.
23. Headmaster (C.P.R.)	a) Defective.
24. Water System	a) Water leaks causing short freeze time.

## 2. Freeze-Up

Defrost and clean the unit prior to diagnosing a freeze-up. See "VI.A. Cleaning and Sanitizing Instructions." Fill out a freeze-up checklist. The freeze-up checklist can be found in the Hoshizaki Technician's Pocket Guide or contact your local distributor for a copy of the freeze-up checklist.

<b>Freeze-Up - Possible Cause</b>	
<b>Harvest Cycle</b>	
1. Evaporator	a) Scaled up.
	b) Damaged.
2. Cube Guides	a) Out of position.
	b) Damaged.
3. Spray Tubes and/or Spray Guides	a) Dirty.
	b) Out of position.
4. Water Supply	a) Low water pressure.
	b) External water filters clogged.
	c) Insufficient water line size. Minimum 3/8" nominal ID copper water tubing or equivalent.
5. Inlet Water Valve	a) Screen or orifice clogged.
	b) Defective.

<b>Freeze-Up - Possible Cause</b>	
6. Float Switch See "IV.D. Float Switch Check and Cleaning"	a) Dirty, sticking.
	b) Defective.
7. Refrigerant Charge	a) Low.
8. Control Board See "II.C.3. Controls and Adjustments" and "IV.B. Control Board Check"	a) Harvest timer (S1 dip switch 1 & 2) set too short.
	b) Harvest pump timer (S1 dip switch 7 & 8) not in factory default position.
	c) Defective.
9. Bin Control See "IV.C. Bin Control Check and Cleaning"	a) Actuator does not move freely.
10. Thermistor See "IV.E. Thermistor Check"	a) Loose, disconnected, or defective.
11. Thermostatic Expansion Valves	a) Defective.
12. Hot Gas Valves (KMS & SRK)	a) Closed or restricted.
13. Liquid Line Valves (KMS & SRK)	a) Open.
<b>Freeze Cycle</b>	
1. Evaporator	a) Scaled up.
	b) Damaged.
2. Spray Tubes and/or Spray Guides	a) Dirty.
	b) Out of position.
3. Refrigerant Charge	a) Low.
4. Control Board See "IV.B. Control Board Check"	a) Freeze timer (S1 dip switch 9 & 10) set incorrectly.
	b) Anti-slush control (S2 dip switch 6) not in factory default position.
	c) Defective.
5. Inlet Water Valve	a) Leaking by.
6. Float Switch See "IV.D. Float Switch Check and Cleaning"	a) Float does not move freely.
	b) Defective.
7. Pump Motor	a) RPM too slow.
	b) Impeller damaged.
8. Thermostatic Expansion Valves	a) Bulb loose or defective.
9. Headmaster (C.P.R.)	a) Defective.

### 3. Low Ice Production

Low Ice Production - Possible Cause	
Long Harvest Cycle	
1. Evaporator	a) Scaled up.
2. Spray Tubes and/or Spray Guides	a) Dirty.
	b) Out of position.
3. Refrigerant Charge	a) Low.
4. Water Supply	a) Low water pressure.
	b) External water filters clogged.
	c) Insufficient water line size. Minimum 3/8" nominal ID copper water tubing or equivalent.
	d) Too cold.
5. Control Board See "IV.B. Control Board Check"	a) Thermistor connection loose.
	b) Defective.
6. Thermistor See "IV.E. Thermistor Check"	a) Loose, disconnected, or defective.
7. Hot Gas Valves (KMS & SRK)	a) Erratic or closed.
8. Inlet Water Valve	a) Screen or orifice clogged.
9. Compressor	a) Inefficient or off.
10. Liquid Line Valves (KMS & SRK)	a) Erratic or closed.
11. Thermostatic Expansion Valves	a) Defective.
12. Headmaster (C.P.R.)	a) Defective.
Short Freeze Cycle	
1. Float Switch See "IV.D. Float Switch Check and Cleaning"	a) Scaled up, dirty.
	b) Float sticking.
	c) Defective switch.
2. Inlet Water Valve	a) Restricted.
3. Control Board See "IV.B. Control Board Check"	a) Float switch connection loose.
	b) Defective.
4. Drain Valve	a) Dirty, leaking by.
Long Freeze Cycle	
1. Evaporator	a) Scaled up, dirty.
2. Float Switch See "IV.D. Float Switch Check and Cleaning"	a) Scaled up, dirty.
	b) Float sticking.
	c) Defective switch.
3. Inlet Water Valve	a) Leaking by.
4. Thermistor See "IV.E. Thermistor Check"	a) Loose, disconnected, or defective.
5. Hot Gas Valves (KMS & SRK)	a) Erratic or open.
6. Condenser	a) Clogged.
7. Control Board See "IV.B. Control Board Check"	a) Float switch connection loose.
	b) Thermistor connection loose.
	c) Defective.

<b>Low Ice Production - Possible Cause</b>	
8. Refrigerant Charge	a) Low.
9. Thermostatic Expansion Valves	a) Bulb loose.
	b) Defective.
10. Compressor	a) Inefficient or off.
11. Pump Motor	a) RPM too slow.
	b) Impeller damaged.
12. Liquid Line Valves (KMS & SRK)	a) Erratic or closed.
13. Headmaster (C.P.R.)	a) Not bypassing.

---

## V. Replacement of Components

### ⚠ WARNING

1. This unit should be diagnosed and repaired only by qualified service personnel to reduce the risk of death, electric shock, serious injury, or fire.
2. Move the control switch to the "OFF" position and turn off the power supply before servicing. Lockout/Tagout to prevent the power from being turned back on inadvertently.
3. **CHOKING HAZARD:** Ensure all components, fasteners, and thumbscrews are securely in place after the unit is serviced. Make sure that none have fallen into the storage bin.
4. Make sure all food zones in the icemaker and storage bin are clean after the unit is serviced. For cleaning procedures, see "VI. Cleaning and Maintenance."

## A. Service for Refrigerant Lines

### ⚠ WARNING

1. Repairs requiring the refrigeration circuit to be opened must be performed by properly trained and EPA-certified service personnel.
2. Always recover the refrigerant and store it in an approved container. Do not discharge the refrigerant into the atmosphere.
3. Use an electronic leak detector or soap bubbles to check for leaks. Add a trace of refrigerant to the system (if using an electronic leak detector), and then raise the pressure using nitrogen gas (140 PSIG). DO NOT use R-404A as a mixture with pressurized air for leak testing.

### NOTICE

1. Do not leave the system open for longer than 15 minutes when replacing or servicing parts. The Polyol Ester (POE) oils used in R-404A units can absorb moisture quickly. Therefore it is important to prevent moisture from entering the system when replacing or servicing parts.
2. Always install a new drier every time the sealed refrigeration system is opened.
3. Do not replace the drier until after all other repair or replacement has been made. Install the new drier with the arrow on the drier in the direction of the refrigerant flow.
4. When brazing, protect the drier by using a wet cloth to prevent the drier from overheating. Do not allow the drier to exceed 250°F (121°C).

### 1. Refrigerant Recovery

The icemaker is provided with refrigerant service valves. Using proper refrigerant practices, recover the refrigerant from the service valves and store it in an approved container. Do not discharge the refrigerant into the atmosphere.

## 2. Brazing

### **⚠ WARNING**

1. R-404A itself is not flammable at atmospheric pressure and temperatures up to 176°F (80°C).
2. R-404A itself is not explosive or poisonous. However, when exposed to high temperatures (open flames), R-404A can be decomposed to form hydrofluoric acid and carbonyl fluoride both of which are hazardous.
3. Do not use silver alloy or copper alloy containing arsenic.
4. Use an electronic leak detector or soap bubbles to check for leaks. Add a trace of refrigerant to the system (if using an electronic leak detector), and then raise the pressure using nitrogen gas (140 PSIG). DO NOT use R-404A as a mixture with pressurized air for leak testing.

- 1) Braze all fittings while purging with nitrogen gas flowing at a pressure of 3 to 4 PSIG.

Note: Because the pipes in the evaporator case are specially coated to resist corrosion, it is important to make connections outside the evaporator case when possible. If it is necessary to braze inside the evaporator case, use sandpaper to remove the coating from the brazing connections before unbrazing the components.

### **NOTICE**

1. Always install a new drier every time the sealed refrigeration system is opened.
2. Do not replace the drier until after all other repair or replacement has been made. Install the new drier with the arrow on the drier in the direction of the refrigerant flow.
3. When brazing, protect the drier by using a wet cloth to prevent the drier from overheating. Do not allow the drier to exceed 250°F (121°C).

- 2) Use an electronic leak detector or soap bubbles to check for leaks. Add a trace of refrigerant to the system (if using an electronic leak detector), and then raise the pressure using nitrogen gas (140 PSIG). DO NOT use R-404A as a mixture with pressurized air for leak testing.

## 3. Evacuation and Recharge (R-404A)

- 1) Attach a vacuum pump to the system. Be sure to connect the charging hoses to both high and low-side service valves.

### **IMPORTANT**

The vacuum level and vacuum pump may be the same as those for current refrigerants. However, the rubber hose and gauge manifold to be used for evacuation and refrigerant charge should be exclusively for POE oils.

- 2) Turn on the vacuum pump. Open the gauge manifold valves, then open the high and low-side service valves. Never allow the oil in the vacuum pump to flow backwards.



- 3) Allow the vacuum pump to pull down to a 29.9" Hg vacuum. Evacuating period depends on pump capacity.
- 4) Close the low-side valve and high-side valve on the gauge manifold.
- 5) Disconnect the gauge manifold hose from the vacuum pump and attach it to a refrigerant service cylinder. Remember to loosen the connection and purge the air from the hose. See the nameplate on the SRK for the required refrigerant charge. Hoshizaki recommends only virgin refrigerant or reclaimed refrigerant which meets ARI Standard 700 (latest edition) be used.
- 6) A liquid charge is required when charging an R-404A system (to prevent fractionation). Place the service cylinder on the scales; if the service cylinder is not equipped with a dip tube, invert the service cylinder, then place it on the scales. Open the high-side valve on the gauge manifold.
- 7) Allow the system to charge with liquid until the proper charge weight is met.
- 8) If necessary, add any remaining charge to the system through the low-side. **NOTICE! To prevent compressor damage, use a throttling valve or liquid dispensing device to add the remaining liquid charge through the low-side service valve with the unit running.**
- 9) Close the high and low-side service valves. Close the high and low-side gauge manifold valves, then disconnect the gauge manifold hoses.
- 10) Cap the service valves to prevent a possible leak.

## B. Important Notes for Component Replacement

### NOTICE

When replacing a component listed below, see the notes to help ensure proper operation.

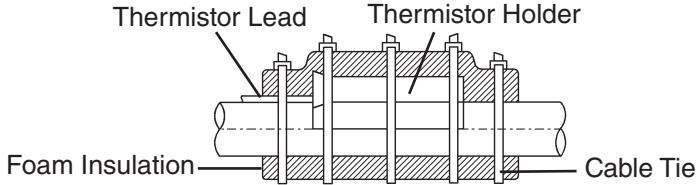
Component	Notes
Compressor	Install a new start capacitor, run capacitor, and start relay (single phase only).
Thermostatic Expansion Valve	<ul style="list-style-type: none"> <li>• Attach the expansion valve bulb to the suction line in the same location as the previous bulb.</li> <li>• The bulb should be between the 10 and 2 o'clock positions on the tube.</li> <li>• Secure the bulb with the clamp and holder, then insulate it.</li> </ul>
Hot Gas Valves & Liquid Line Valves	<ul style="list-style-type: none"> <li>• Replace the strainer when replacing a hot gas valve.</li> <li>• Use copper tube of the same diameter and length when replacing valve lines.</li> </ul>
Fan Motor	Install a new capacitor.
Pump Motor	Install a new capacitor.
Thermistor	<ul style="list-style-type: none"> <li>• Attach the new thermistor to the suction line in the same location as the previous thermistor.</li> <li>• Smoothly fill the recessed area of the thermistor holder with high thermal conductive type sealant. Hoshizaki America part number 4A0683-01 (Silicone Heat Sink Compound 10-8108 manufactured by GC Electronics), KE-4560 RTV (manufactured by ShinEtsu Silicones), or equivalent are recommended.</li> <li>• Secure the thermistor with the holder, then insulate it.</li> <li>• Be very careful to prevent damage to the leads.</li> </ul> <div style="text-align: center; margin-top: 20px;">  <p>The diagram illustrates the correct installation of a thermistor. It shows a cross-section of a suction line with a thermistor holder mounted on it. The holder is secured to the line with a cable tie. The thermistor lead is inserted into the holder, and the area between the holder and the line is filled with foam insulation. Labels include 'Thermistor Lead', 'Thermistor Holder', 'Foam Insulation', and 'Cable Tie'.</p> </div>

---

## VI. Cleaning and Maintenance

This icemaker must be cleaned and maintained in accordance with the instruction manual and labels provided with the icemaker. Consult with your local distributor about cleaning and maintenance service. To obtain the name and phone number of your local distributor, visit [www.hoshizaki.com](http://www.hoshizaki.com) or call Hoshizaki Technical Support at 1-800-233-1940 in the USA.

### ▲ WARNING

1. Only qualified service technicians should attempt to service this icemaker.
2. **CHOKING HAZARD:** Ensure all components, fasteners, and thumbscrews are securely in place after any cleaning or maintenance is done to the unit. Make sure that none have fallen into the dispenser unit/storage bin.
3. The dispenser unit/storage bin is for ice use only. Do not store anything else in the dispenser unit/storage bin.

## A. Cleaning and Sanitizing Instructions

Hoshizaki recommends cleaning and sanitizing this unit at least once a year. More frequent cleaning and sanitizing, however, may be required in some existing water conditions.

### ▲ WARNING

1. To prevent injury to individuals and damage to the icemaker, do not use ammonia type cleaners.
2. Carefully follow any instructions provided with the bottles of cleaning and sanitizing solution.
3. Always wear liquid-proof gloves and goggles to prevent the cleaning and sanitizing solutions from coming into contact with skin or eyes.
4. To prevent damage to the water pump seal, do not operate the icemaker with the control switch in the "SERVICE" position when the water tank is empty.

## 1. Cleaning Procedure

- 1) Dilute 27 fl. oz. (800 ml) of Hoshizaki "Scale Away" with 5 gal. (19 l) of warm water.
- 2) Remove all ice from the evaporator and the dispenser unit/storage bin.  
Note: To remove cubes on the evaporator, turn off the power supply and turn it back on after 3 minutes. The harvest cycle starts and the cubes will be removed from the evaporator.
- 3) Turn off the power supply.
- 4) Remove the front panel, then place the control switch in the "SERVICE" position. Then place the service switch in the "DRAIN" position.
- 5) Replace the front panel in its correct position, then turn on the power supply for 2 minutes.
- 6) Turn off the power supply.
- 7) Remove the front panel.

- 8) In bad or severe water conditions, clean the float switch as described below. Otherwise, continue to step 9.
  - a. Remove the right side panel.
  - b. Disconnect the flush tube from the top of the float switch housing, then remove the float switch assembly. Remove the rubber boot from the bottom of the assembly.
  - c. Remove the retainer rod from the bottom of the float switch housing, then remove the float. Be careful not to bend the retainer rod excessively when removing it
  - d. Wipe down the float switch assembly housing, shaft, float, and retainer rod with cleaning solution. Clean the inside of the rubber boot and hose with cleaning solution. Rinse the parts thoroughly with clean water.
  - e. Reassemble the float switch assembly and replace it and the rubber boot in their correct positions. Reconnect the flush tube.
  - f. Replace the right side panel in its correct position.
- 9) Remove the insulation panel by removing the thumbscrews, then pour the cleaning solution into the water tank.
- 10) Move the service switch to the "WASH" position.
- 11) Replace the insulation panel and the front panel in their correct positions.
- 12) Turn on the power supply to start the washing process.
- 13) Turn off the power supply after 30 minutes. Remove the front panel.
- 14) Move the service switch to the "DRAIN" position.
- 15) Replace the front panel in its correct position, then turn on the power supply for 2 minutes.
- 16) Turn off the power supply, then remove the front panel.
- 17) Move the control switch to the "ICE" position.
- 18) Replace the front panel in its correct position.
- 19) Turn on the power supply to fill the water tank with water.
- 20) Turn off the power supply after 3 minutes.
- 21) Remove the front panel.
- 22) Move the control switch to the "SERVICE" position, then move the service switch to the "WASH" position.
- 23) Replace the front panel in its correct position.
- 24) Turn on the power supply to rinse off the cleaning solution.
- 25) Turn off the power supply after 5 minutes.
- 26) Remove the front panel.
- 27) Move the service switch to the "DRAIN" position.
- 28) Replace the front panel in its correct position, then turn on the power supply for 2 minutes.
- 29) Turn off the power supply. Remove the front panel.
- 30) Repeat steps 17 through 29 three more times to rinse thoroughly.

Note: If you do not sanitize the icemaker, go to step 13 in "2. Sanitizing Procedure."

## **2. Sanitizing Procedure - Following Cleaning Procedure**

- 1) Dilute 2.5 fl. oz. (74 ml or 5 tbs) of a 5.25% sodium hypochlorite solution (chlorine bleach) with 5 gal. (19 l) of warm water.
- 2) Remove the insulation panel if it is in its normal position.
- 3) Pour the sanitizing solution into the water tank.
- 4) Move the service switch to the "WASH" position.
- 5) Replace the insulation panel and the front panel in their correct positions.
- 6) Turn on the power supply to start the sanitizing process.
- 7) Turn off the power supply after 15 minutes. Remove the front panel.
- 8) Move the service switch to the "DRAIN" position.
- 9) Replace the front panel in its correct position, then turn on the power supply for 2 minutes.
- 10) Turn off the power supply. Remove the front panel.
- 11) Repeat steps 17 through 29 in "1. Cleaning Procedure" two times to rinse thoroughly.
- 12) Repeat steps 1 through 11 one more time.
- 13) Move the control switch to the "ICE" position.
- 14) Replace the front panel in its correct position.
- 15) Clean the dispenser unit/storage bin liner using a neutral cleaner. Rinse thoroughly after cleaning.
- 16) Turn on the power supply to start the automatic icemaking process.

## B. Maintenance

This icemaker must be maintained individually, referring to the instruction manual and labels provided with the icemaker.

### WARNING

1. Only qualified service technicians should attempt to service this icemaker.
2. Move the control switch to the "OFF" position and turn off the power supply to the SRK condensing unit before servicing the KMS or SRK. Place the KMS disconnect (if applicable) in the off position. Lockout/Tagout to prevent the power supply from being turned back on inadvertently.

#### 1. Stainless Steel Exterior

To prevent corrosion, wipe the exterior occasionally with a clean, soft cloth. Use a damp cloth containing a neutral cleaner to wipe off oil or dirt buildup.

#### 2. Dispenser Unit/Storage Bin and Scoop

- Wash your hands before removing ice. Use the plastic scoop provided (bin accessory).
- The dispenser unit/storage bin is for ice use only. Do not store anything else in the dispenser unit/storage bin.
- Clean the scoop and the dispenser unit/storage bin liner using a neutral cleaner. Rinse thoroughly after cleaning.

#### 3. Condenser

Check the condenser once a year, and clean the coil if required by using a brush or vacuum cleaner. More frequent cleaning may be required depending on location.

## C. Preparing the Icemaker for Long Storage

### **NOTICE**

1. When storing the icemaker for an extended time or in sub-freezing temperatures, follow the instructions below to prevent damage.
2. To prevent damage to the water pump, do not operate the icemaker with the control switch in the "SERVICE" position when the water tank is empty.

When the icemaker is not used for two or three days under normal conditions, it is sufficient to move the control switch to the "OFF" position. When storing the icemaker for an extended time or in sub-freezing temperatures, follow the instructions below.

#### **1. Remove the water from the icemaker water lines:**

- 1) Turn off the power supply, then remove the front panel, right side panel, and control box cover.
- 2) Move the control switch on the control box to the "OFF" position. Confirm the service switch is in the "CIRC" position.
- 3) Close the icemaker water supply line shut-off valve and open the icemaker water supply line drain valve. Allow the line to drain by gravity.
- 4) Attach a compressed air or carbon dioxide supply to the icemaker water supply line drain valve.
- 5) Turn on the power supply, then move the control switch to the "ICE" position. Confirm that the bin control switch is closed and calling for ice. The control board red "POWER OK" LED should be on and not flashing.
- 6) Blow the icemaker water supply line out using the compressed air or carbon dioxide supply. This will clear water from the inlet water valve.
- 7) Move the control switch to the "OFF" position.
- 8) Disconnect the wash valve hose from the inlet water valve tee, then unplug the water pump connector at the water pump. See Fig. 4.
- 9) Move the service switch to the "WASH" position, then move the control switch to the "SERVICE" position.
- 10) From the wash valve hose, blow out the wash valve using the compressed air or carbon dioxide supply. Reconnect the wash valve hose.
- 11) Move the service switch to the "CIRC" position, then move the control switch to the "OFF" position.
- 12) Disconnect the float switch vent hose from the drain hose tee. Move the service switch to the "DRAIN" position, then move the control switch to the "SERVICE" position.
- 13) From the drain hose tee, blow out the drain valve using the compressed air or carbon dioxide supply. Reconnect the float switch vent hose.
- 14) Move the service switch to the "CIRC" position, then move the control switch to the "OFF" position.
- 15) Turn off the power supply, then reconnect the water pump connector.
- 16) Close the icemaker water supply line drain valve.

**2. Remove the water from the water tank:**

- 17) Remove the insulation panel and front frame.
- 18) Remove the 4 hoses connected to the water tank. Allow the tank and hoses to drain completely. See Fig. 5.
- 19) Remove all ice from the dispenser unit/storage bin and clean the dispenser unit/storage bin liner using a neutral cleaner. Rinse thoroughly after cleaning.
- 20) Reconnect the 4 hoses connected to the water tank.
- 21) Replace all removed parts and panels in their correct positions.

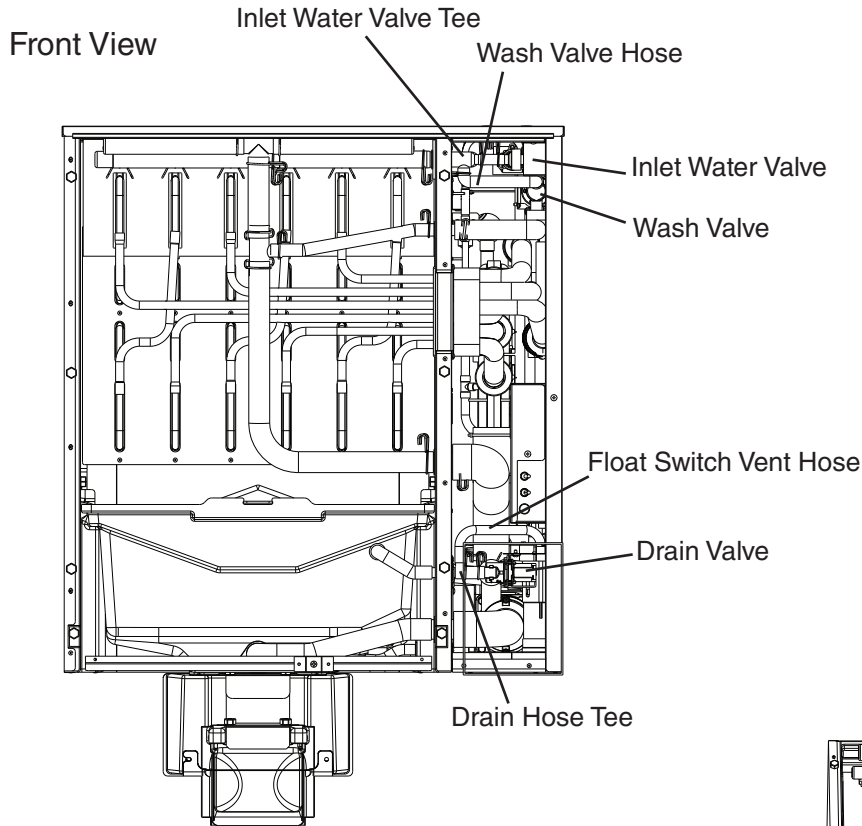

**Fig. 4**

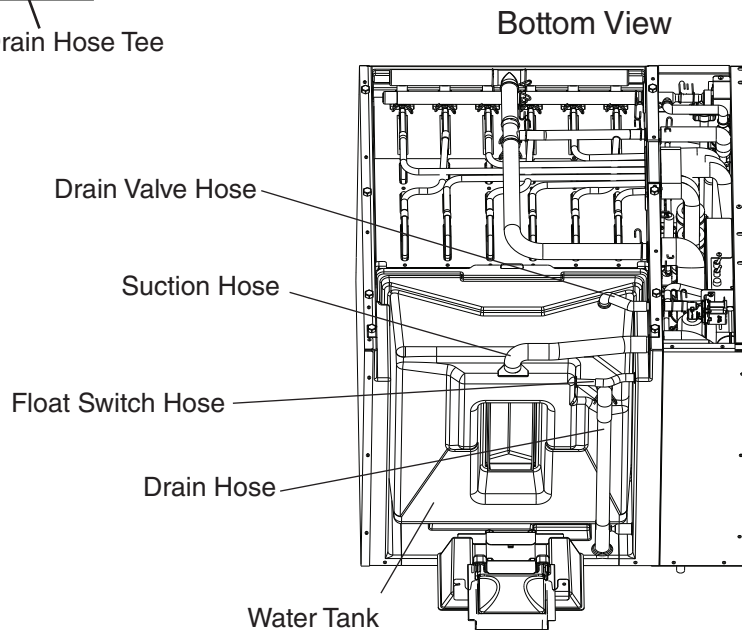

**Fig. 5**