

Hoshizaki America, Inc.

Modular Crescent Cuber Serenity Series

Model
KMS-822MLH

Including
Condensing Unit Model SRK-10H



“A Superior Degree
of Reliability”

www.hoshizaki.com

SERVICE MANUAL



Number: 73182
Issued: 2-18-2011

IMPORTANT

Only qualified service technicians should install, service, and maintain the icemaker. No service or maintenance should be undertaken until the technician has thoroughly read this Service Manual. Failure to service and maintain the equipment in accordance with this manual may adversely affect safety, performance, component life, and warranty coverage.

Hoshizaki provides this manual primarily to assist qualified service technicians in the service and maintenance of the icemaker.

Should the reader have any questions or concerns which have not been satisfactorily addressed, please call, write, or send an e-mail message to the Hoshizaki Technical Support Department for assistance.

HOSHIZAKI AMERICA, INC.
618 Highway 74 South
Peachtree City, GA 30269

Attn: Hoshizaki Technical Support Department

Phone: 1-800-233-1940 Technical Support
(770) 487-2331

Fax: 1-800-843-1056
(770) 487-3360

E-mail: techsupport@hoshizaki.com

Web Site: www.hoshizaki.com

NOTE: To expedite assistance, all correspondence/communication **MUST** include the following information:

- Model Number _____
- Serial Number _____
- Complete and detailed explanation of the problem.

IMPORTANT

This manual should be read carefully before the icemaker is serviced or maintenance operations are performed. Only qualified service technicians should install, service, and maintain the icemaker. Read the warnings contained in this booklet carefully as they give important information regarding safety. Please retain this booklet for any further reference that may be necessary.

CONTENTS

Important Safety Information	5
I. Specifications.....	7
A. Icemaker	7
B. Condensing Unit.....	8
II. General Information	9
A. Construction	9
1. Icemaker	9
2. Condensing Unit.....	10
B. Sequence of Operation	11
1. Sequence Cycles and Shutdown	11
a) 1-Minute Fill Cycle	11
b) Initial Harvest Cycle	11
c) Freeze Cycle	11
d) Pump-Out Cycle.....	12
e) Harvest Cycle.....	12
f) Shutdown.....	12
2. Sequence Flow Chart.....	13
C. Control Board	14
1. Control Board Layout	15
2. LED Lights and Audible Alarm Safeties	16
3. Controls and Adjustments.....	17
a) Default Dip Switch Settings.....	17
b) Harvest Timer (S4 dip switch 1 & 2).....	17
c) Pump-Out Timer (S4 dip switch 3 & 4)	18
d) Pump-Out Frequency Control (S4 dip switch 5 & 6).....	18
e) Harvest Pump Timer (S4 dip switch 7).....	19
f) Factory Use (S4 dip switch 8)	19
g) Freeze Timer (S4 dip switch 9 & 10)	19
h) Float Switch Control (S5 dip switch 1)	20
i) Refill Counter (S5 dip switch 2 through 5).....	20
D. Control Switch	20
III. Technical Information	21
A. Water Circuit and Refrigeration Circuit	21
B. Wiring Diagram.....	22
C. Performance Data	23

IV. Service Diagnosis	24
A. Diagnostic Procedure	24
B. Control Board Check	27
C. Bin Control Check and Cleaning	28
1. Bin Control Check	28
2. Bin Control Cleaning.....	30
D. Float Switch Check and Cleaning	31
1. Float Switch Check	31
2. Float Switch Cleaning.....	32
E. Thermistor Check.....	33
F. Diagnostic Charts	34
1. No Ice Production.....	34
2. Freeze-Up.....	35
3. Low Ice Production	37
V. Replacement of Components	38
A. Service for Refrigerant Lines.....	38
1. Refrigerant Recovery	38
2. Brazing	39
3. Evacuation and Recharge (R-404A).....	39
B. Important Notes for Component Replacement.....	41
VI. Cleaning and Maintenance.....	42
A. Cleaning and Sanitizing Instructions	42
1. Cleaning Procedure.....	43
2. Sanitizing Procedure - Following Cleaning Procedure	45
B. Maintenance.....	46
C. Preparing the Icemaker for Long Storage	46

Important Safety Information

Throughout this manual, notices appear to bring your attention to situations which could result in death, serious injury, or damage to the unit.

⚠ WARNING Indicates a hazardous situation which could result in death or serious injury.

CAUTION Indicates a situation which could result in damage to the unit.

IMPORTANT Indicates important information about the use and care of the unit.

⚠ WARNING

This icemaker should be destined only to the use for which it has been expressly conceived. Any other use should be considered improper and therefore dangerous. The manufacturer cannot be held responsible for injury or damage resulting from improper, incorrect, and unreasonable use.

To reduce the risk of death, electric shock, serious injury, or fire, follow basic precautions including the following:

- This unit should be disassembled or repaired only by qualified service personnel to reduce the risk of electric shock, injury, or fire.
- Move the control switch to the "OFF" position and turn off the power supply to the SRK condensing unit before any servicing to the KMS or SRK is undertaken. Place the KMS disconnect (if applicable) in the off position. Lockout/Tagout to prevent the power supply from being turned back on inadvertently.
- Do not make any alterations to the unit. Alterations could result in electric shock, injury, fire, or damage to the unit.

For KMS

- Power supply and ground connection are supplied from the SRK remote condensing unit via the wire harness provided. Do not connect the wire harness leads to an external power source.
- Wire harness routing (conduit) and disconnect (if required) must meet national, state, and local electrical code requirements. Failure to meet these code requirements could result in death, electric shock, serious injury, fire, or severe damage to equipment.
- **THE ICEMAKER MUST BE GROUNDED.** Failure to properly ground the icemaker could result in death, serious injury, or severe damage to equipment.

For SRK

- Electrical connection must be hard-wired and must meet national, state, and local electrical code requirements. Failure to meet these code requirements could result in death, electric shock, serious injury, fire, or severe damage to equipment.
- The remote condensing unit requires an independent power supply of proper capacity. See the nameplate for electrical specifications. Failure to use a properly sized breaker or fuse can result in a tripped breaker, blown fuses, or damage to existing wiring. This could lead to heat generation or fire.
- **THE REMOTE CONDENSING UNIT MUST BE GROUNDED.** Failure to properly ground the remote condensing unit could result in death or serious injury.

I. Specifications

A. Ice maker

1. KMS-822MLH

AC SUPPLY VOLTAGE	115VAC Supplied by SRK-10H via Factory Supplied Wire Harness			
APPROXIMATE ICE PRODUCTION PER 24 HR. lbs./day (kg/day) Reference without *marks	Ambient Temp.(°F)	WATER TEMP. (°F)		
		50	70	90
	70	*839 (381)	820 (372)	769 (349)
	80	824 (374)	795 (361)	730 (331)
	90	820 (372)	*774 (351)	714 (324)
	100	801 (364)	760 (345)	659 (299)
SHAPE OF ICE	Crescent Cube			
ICE PRODUCTION PER CYCLE	13.6 lb. (6.2 kg) 624 pcs.			
ELECTRIC & WATER CONSUMPTION	90/70°F	70/50°F		
KMS/SRK COMBINED ELECTRIC W (kWH/100 lbs.)	1800 (5.58)	1710 (4.89)		
WATER gal./24HR (gal./100 lbs.)	149 (19.3)	363 (43.3)		
EXTERIOR DIMENSIONS (W×D×H)	22"×24-5/8"×28" (559×625×713 mm)			
EXTERIOR FINISH	Stainless Steel, Galvanized Steel (rear)			
WEIGHT	Net 122 lb. (55 kg), Shipping 152 lb. (69 kg)			
CONNECTIONS - ELECTRIC	Wire Harness Connection from SRK to KMS			
- WATER SUPPLY	Inlet	1/2" FPT		
- DRAIN	Outlet	3/4" FPT		
- CONDENSATION		5/8" OD Tube		
- REFRIGERATION	Liquid Line	1/2" Copper Tube Field Connection		
	Suction Line	5/8" Copper Tube Field Connection		
CUBE CONTROL SYSTEM	Float Switch			
HARVEST CONTROL SYSTEM	Hot Gas and Water, Thermistor and Timer			
ICE MAKING WATER CONTROL	Timer Controlled, Overflow Pipe, Float Switch			
COOLING WATER CONTROL	N/A			
BIN CONTROL SYSTEM	Mechanical Bin Control			
COMPRESSOR	In SRK			
CONDENSING UNIT	Air-Cooled Remote Condensing Unit SRK-10H			
EVAPORATOR	Vertical type, Stainless Steel and Copper			
REFRIGERANT CONTROL	Thermostatic Expansion Valve			
	Headmaster (C.P.R.) in SRK-10H (160 PSI)			
REFRIGERANT CHARGE	404A, 14 lb. 15.9 oz. (6800 g) (Ice maker 0 lb. 7.1 oz. (200 g)) (Cond. Unit 14 lb. 8.8 oz. (6600 g))			
DESIGN PRESSURE	High 467 PSIG, Low 230 PSIG			
CONTROL BOARD CIRCUIT PROTECTION	High Voltage Cut-out (Internal)			
REFRIGERATION CIRCUIT PROTECTION	Auto-Reset High Pressure Switch in SRK-10H			
LOW WATER PROTECTION	Float Switch			
ACCESSORIES -SUPPLIED	Mechanical Bin Control Extension Bracket			
-REQUIRED	Dispenser Unit or Ice Storage Bin SRK-10H Remote Condensing Unit			
OPERATING CONDITIONS	VOLTAGE RANGE	104-127VAC		
	AMBIENT TEMP.	45 -100°F		
	WATER SUPPLY TEMP.	45 - 90°F		
	WATER SUPPLY PRESSURE	10 - 113 PSIG		

Note: We reserve the right to make changes in specifications and design without prior notice.

B. Condensing Unit

1. SRK-10H

AC SUPPLY VOLTAGE	208-230/60/1 (3 wire with neutral for 115VAC) (115VAC Supplied to KMS via Factory Wire Harness)		
AMPERAGE	11.5A (5 Min. Freeze AT 104°F / WT 80°F)		
MINIMUM CIRCUIT AMPACITY	20A		
MAXIMUM FUSE SIZE	20A		
EXTERIOR DIMENSIONS (W×D×H)	50"×17"×28" (1270×432×711 mm)		
DIMENSIONS INCLUDING LEGS (W×D×H)	52-3/8"×19-1/2"×43" (1330×495×1092 mm)		
EXTERIOR FINISH	Galvanized Steel		
WEIGHT	Net 230 lb. (104 kg)	Shipping 273 lb. (124 kg)	
CONNECTIONS - ELECTRIC	Main Power Supply: Permanent Connection SRK to KMS: Wire Harness Connection		
- REFRIGERATION	Liquid Line	1/2" Copper Tube Field Connection	
	Suction Line	5/8" Copper Tube Field Connection	
COMPRESSOR	Hermetic, Model CS10K6E-PFV-279		
CONDENSER	Air Cooled, Fin and Tube Type		
COMPRESSOR PROTECTION	Auto-Reset Overload Protector (Internal)		
FAN MOTOR PROTECTION	Thermal Protection		
REFRIGERATION CIRCUIT PROTECTION	Auto-Reset High Pressure Switch Discharge Line Thermostat		
REFRIGERANT CONTROL	Headmaster (C.P.R.) (160 PSI)		
REFRIGERANT CHARGE	404A, 14 lb. 15.9 oz. (6800 g) (Condensing Unit 14 lb. 8.8 oz. (6600 g)) (Icemaker 0 lb. 7.1 oz. (200 g))		
DESIGN PRESSURE	High 467 PSIG, Low 230 PSIG		
OPERATING CONDITIONS	VOLTAGE RANGE	187-253VAC	
	AMBIENT TEMP. (Outdoor Use)	-20-122°F	
ACCESSORIES -SUPPLIED	Leg		2 pcs
	Hex Head Bolt w/Washer	M8×16	16 pcs
	Hex Nut	M8	16 pcs
-REQUIRED	Compatible KMS Icemaker		

Note: We reserve the right to make changes in specifications and design without prior notice.

II. General Information

A. Construction

1. Icemaker

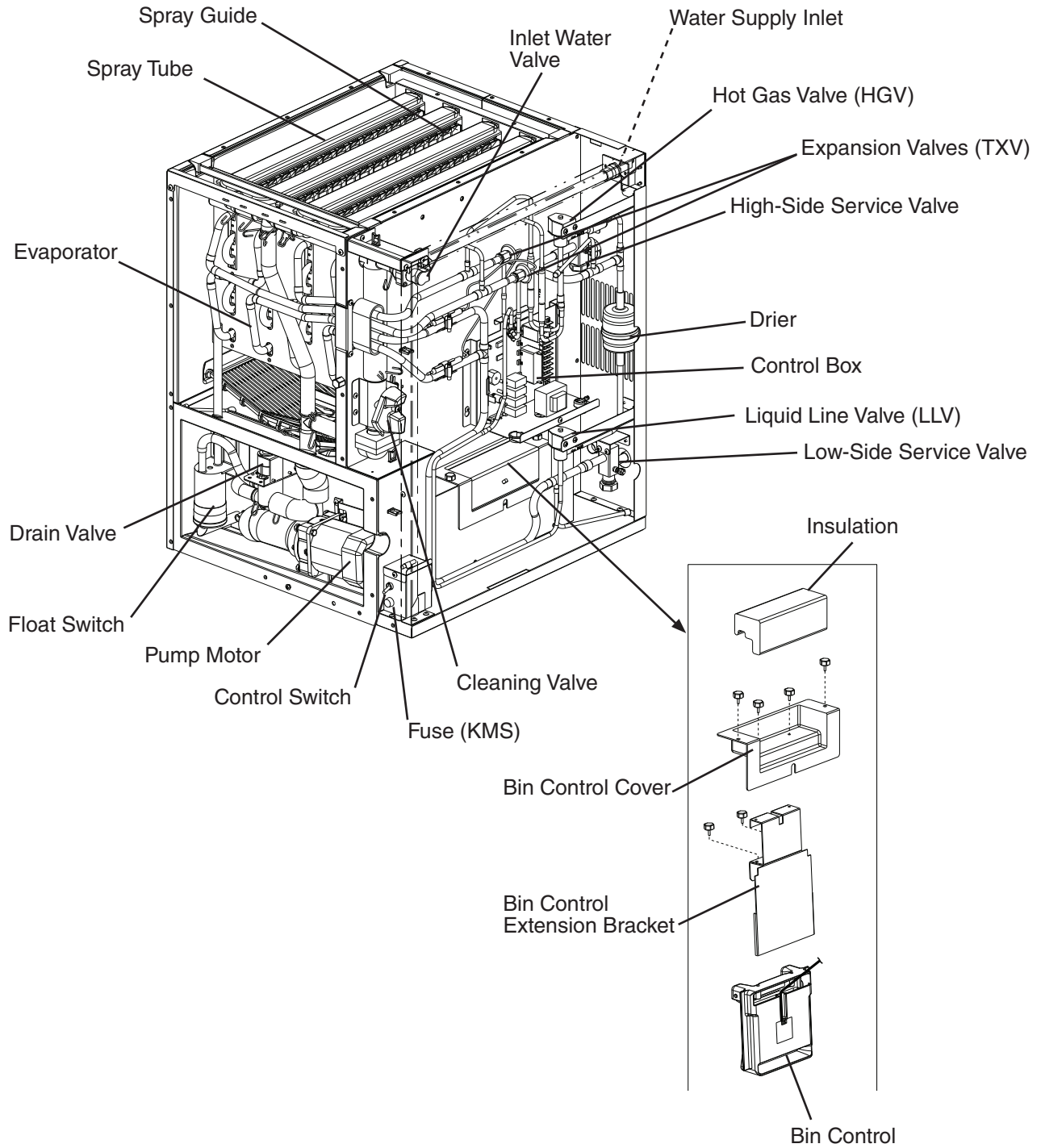

2. Condensing Unit

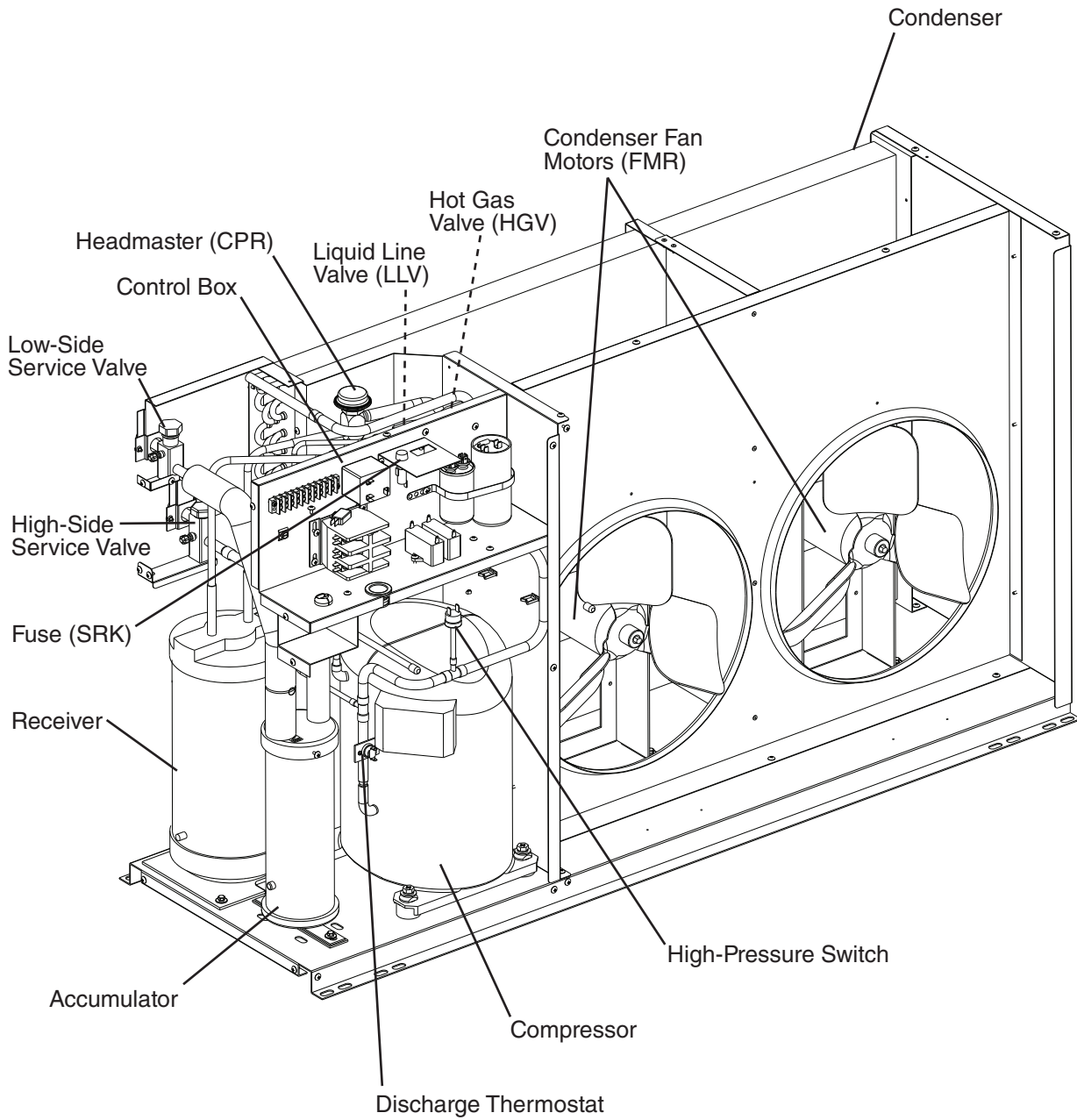

B. Sequence of Operation

1. Sequence Cycles and Shutdown

The steps in the sequence are as outlined below. When power is supplied, CB red "POWER OK" LED and green "BC CLOSED" LED come on. If yellow "BC OPEN" LED is on, the unit will not start. In this case, clear ice away from the BC actuator paddle in the dispenser unit/storage bin area. A 5-second delay occurs at startup. Note that the order of the green sequence LEDs from the outer edge of CB is 1, 4, 3, 2.

a) 1-Minute Fill Cycle

LED 4 is on. WV energizes and the 1-minute fill cycle begins. After 1 minute, CB checks for a closed F/S. If F/S is closed, the harvest cycle begins. If not, WV remains energized through additional 1-minute fill cycles until water fills the tank and closes F/S. This serves as a low water safety to protect PM.

b) Initial Harvest Cycle

LEDs 1, 4, and 2 are on. WV remains energized, Comp, FMRs, and HGVs energize. CB monitors the warming of the evaporator via the thermistor located on the suction line. When the thermistor reaches 48°F (9°C), CB reads a 3.9 kΩ signal from the thermistor and turns harvest termination over to the adjustable harvest timer which is factory set for normal conditions. For details, see "II.C.3.b) Harvest Timer (S4 dip switch 1 & 2)." WV is energized during harvest for a maximum of 6 minutes or the length of harvest minus 50 seconds (Harvest Pump Timer (S4 dip switch 7)), whichever is shorter. 50 seconds before the harvest timer terminates, LED 4 and WV de-energize. LED 3 comes on, DVR energizes, energizing PM for the last 50 seconds of harvest. For details, see "II.C.3.e) Harvest Pump Timer (S4 dip switch 7)." **CAUTION! S4 dip switch 7 must remain in the factory default position of 7 on. Otherwise, PM will not energize during the last 50 seconds of harvest.** The pump-out timer (S4 dip switch 3 & 4) acts in place of the harvest timer during cycles with a pump-out. For details, see "II.C.3.c) Pump-Out Timer (S4 dip switch 3 & 4). The minimum total time allowed by CB for a complete harvest cycle is 2 minutes. At the end of harvest, CB checks the position of F/S and proceeds to the freeze cycle if it is closed or calls for a 1-minute fill cycle if it is open.

c) Freeze Cycle

LED 1 is on. Comp, FMRs, and PM continue. LLVs energize. HGVs de-energize. For the first 5 minutes, CB will not terminate the freeze cycle. At the end of 5 minutes, F/S assumes control of the freeze cycle. As ice builds on the evaporator, the water level in the tank lowers. The freeze cycle continues until F/S opens. There is a 15 second delay before CB acknowledges an open F/S, CB then terminates the freeze cycle.

d) Pump-Out Cycle

LEDs 1, 4, 3, and 2 are on. Comp and FMRs remain energized, HGVs and WV energize. LLVs de-energize. PM stops for 2 seconds, then DVR energizes, energizing PM and DV for 10 seconds. Water is removed from the bottom of the tank and sent down the drain. At the same time, water flows through the small F/S tube to power flush F/S. When the pump-out timer terminates, pump-out is complete. **CAUTION! S4 dip switch 3 & 4 must remain in the factory default position of 3 off and 4 on. Otherwise, DV will not energize during pump-out.**

The first pump-out occurs after the 11th freeze cycle, then every 10th cycle thereafter. The pump-out frequency control is factory set, and generally no adjustment is required. However, where water quality is bad and the icemaker needs a pump-out more often, the pump-out frequency can be adjusted. The pump-out frequency control (S4 dip switch 5 & 6) can be set to have a pump-out occur every cycle, or every 2, 5, or 10 cycles. Timing of the first pump-out is dependent on S4 dip switch 5 & 6 settings. See the table below.

S4 Dip Switch Setting		Pump-Out Frequency	1st Pump-Out
No. 5	No. 6		
OFF	OFF	Every cycle	After 2nd freeze cycle
ON	OFF	Every 2 cycles	After 3rd freeze cycle
OFF	ON	Every 5 cycles	After 6th freeze cycle
ON	ON	Every 10 cycles	After 11th freeze cycle

e) Harvest Cycle

Same as the initial harvest cycle. See "II.B.1.b) Initial Harvest Cycle."

Note: Unit continues to cycle until BC is satisfied or power is turned off. The unit always restarts at the 1-minute fill cycle.

f) Shutdown

When BC is activated (BC open), the yellow "BC OPEN" LED comes on. The unit then shuts down as outlined in the table below. For further details, see "IV.C. Bin Control Check and Cleaning."

Cycle at Bin Control Activation	Shutdown
Fill Cycle	15 seconds after activation.
Harvest Cycle	At the end of the harvest cycle, or up to 15 seconds into the freeze cycle if activated at the end of the harvest cycle.
Freeze Cycle	15 seconds after activation if activated at least 15 seconds before the 5-minute short cycle protection timer terminates. Otherwise, at the end of the next harvest cycle.

Legend: **BC**–bin control; **CB**–control board; **Comp**–compressor; **DV**–drain valve; **DVR**–drain valve relay (X10); **FMRs**–fan motors-remote; **F/S**–float switch; **HGVs**–hot gas valves (KMS and SRK); **LLVs**–liquid line valves (KMS and SRK); **PM**–pump motor; **WV**–inlet water valve

2. Sequence Flow Chart

"G" Control Board Sequence Flow Chart KMS-822MLH/SRK-10H

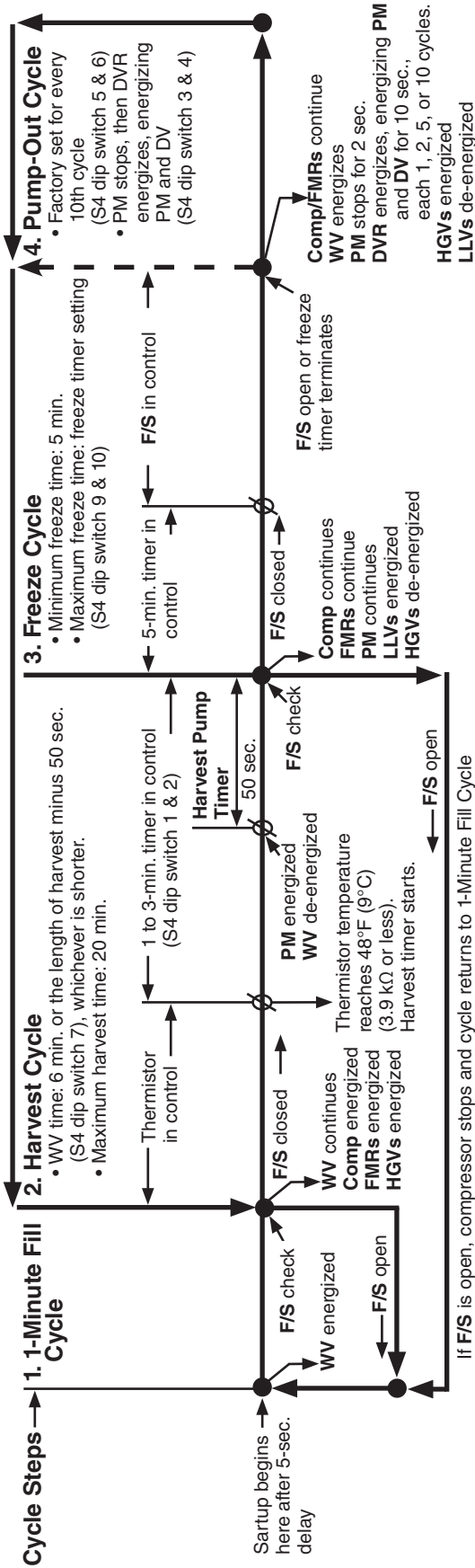

Components Energized when the Control Switch is in the "WASH" Position

The "WASH" position on the control switch is used when cleaning and sanitizing the unit. When in the "WASH" position, power is supplied to the pump motor. With the cleaning valve closed, the cleaner and sanitizer flow over the outside of the evaporator plate assembly. With the cleaning valve open, the cleaner and sanitizer flow over both the outside and the inside of the evaporator plate assembly.

Note: Close the cleaning valve after cleaning and sanitizing are complete, otherwise the unit will not re-start when the control switch is placed in the "ICE" position.

C. Control Board

- A Hoshizaki exclusive solid-state control board is employed in Hoshizaki Crescent Cubers.
- All models are pretested and factory set.

CAUTION

1. The control board is fragile; handle very carefully.
2. The control board contains integrated circuits, which are susceptible to failure due to static discharge. It is especially important to touch the metal part of the unit before handling or replacing the control board.
3. Do not touch the electronic devices on the control board or the back of the control board.
4. Do not change wiring and connections. Do not misconnect K3, K4, and K5, because the same connector is used for the thermistor, bin control, and float switch.
5. Always replace the whole control board assembly if it goes bad.
6. Do not short out power supply to test for voltage.

1. Control Board Layout

"G" Control Board

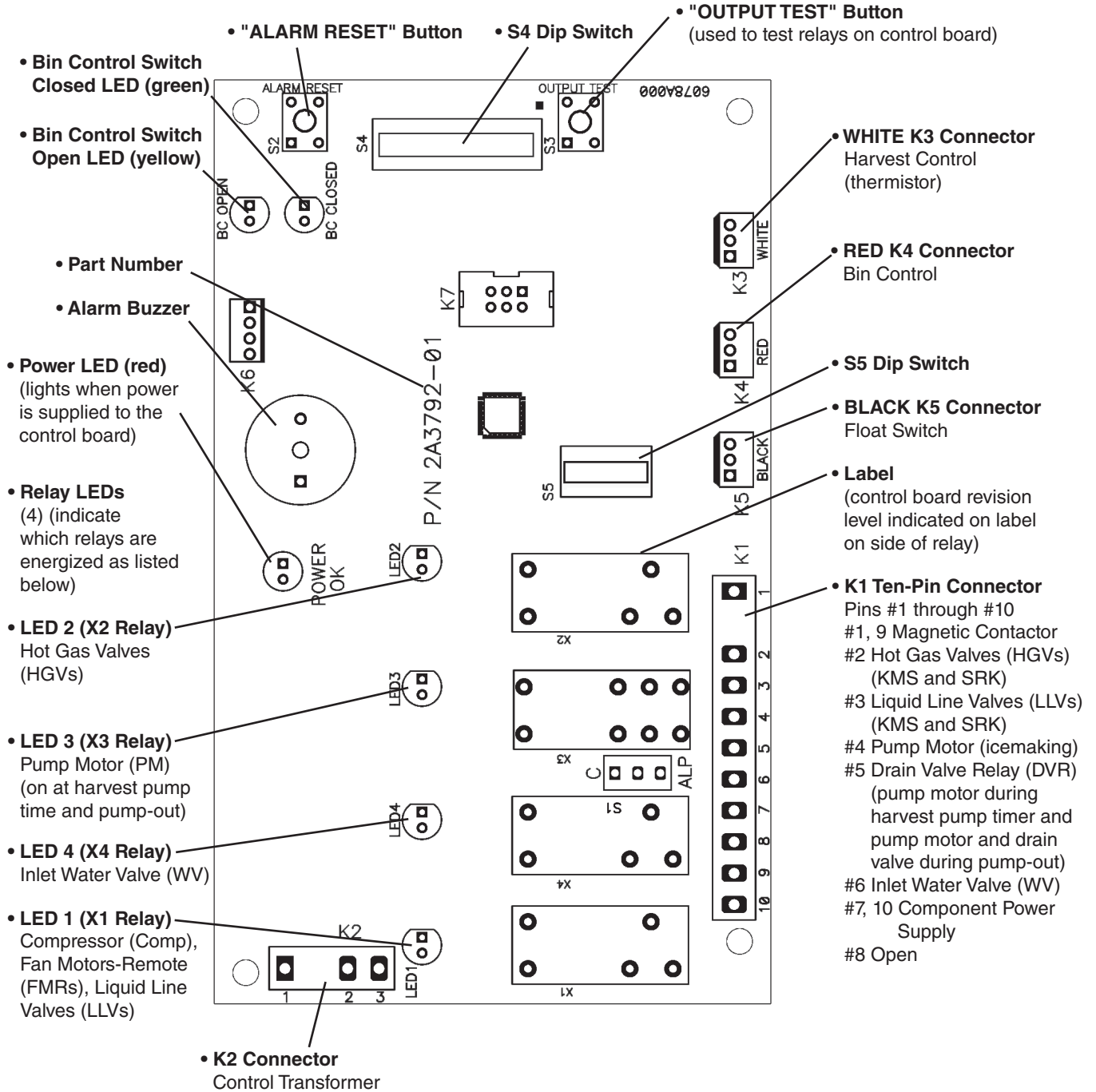

"G" Control Board	
Part Number	2A3792-01

2. LED Lights and Audible Alarm Safeties

At startup, a 5-second delay occurs while the control board conducts an internal timer check. A beep occurs when the control switch is moved to the "ICE" position.

The red LED indicates proper control voltage and remains on unless a control voltage problem occurs. The green LEDs 1 through 4 energize and sequence from initial startup as listed in the table below. Note that the order of the LEDs from the outer edge of the control board is 1, 4, 3, 2. For details, see "II.B. Sequence of Operation."

Sequence Step	LED	Energized Components	Time LEDs are On		
			Min.	Max.	Avg.
1-Minute Fill Cycle	4	WV			1 minute
Harvest Cycle	1, 4, 2	Comp, FMRs, WV, HGVs	2 minutes	20 minutes	3 to 5 minutes
Harvest Pump Timer	1, 3, 2	Comp, FMRs, DVR, PM, HGVs	0 seconds	50 seconds	harvest pump timer setting
Freeze Cycle	1	Comp, FMRs, PM, LLVs	5 minutes	freeze timer setting	30 to 35 minutes
Pump-Out Cycle	1, 4*, 3, 2	Comp, FMRs, HGVs, WV*, DVR, PM, DV	10 seconds	20 seconds	*pump-out timer setting

The built-in safeties shut down the unit and have alarms as listed below.

No. of Beeps (every 3 sec.)	Type of Alarm	Notes
1	High Evaporator Temp. (temperature > 127°F (53°C))	Check for harvest problem (stuck HGV), hot water entering unit, stuck HM, or shorted thermistor.
2	Harvest Backup Timer (harvest > 20 min. for two cycles in a row)	Check for open thermistor, HGV not opening, TXV or LLVs leaking by, low charge, or inefficient Comp.
3	Freeze Timer (freeze > freeze timer setting for two cycles in a row) Timer is factory set using S4 dip switch 9 & 10	Check for F/S stuck closed (up), WV leaking by, HGVs leaking by, PM not pumping, TXV not feeding properly, LLVs not opening, low charge, HM not bypassing, or inefficient Comp.
To reset the above safeties, press the "ALARM RESET" button with the power supply on.		
6	Low Voltage (92Vac±5% or less)	Red LED turns off if voltage protection operates. The control voltage safeties automatically reset when voltage is corrected.
7	High Voltage (147Vac±5% or more)	

Legend: **Comp**—compressor; **DV**—drain valve; **DVR**—drain valve relay; **FMRs**—fan motors-remote; **F/S**—float switch; **HGVs**—hot gas valves (KMS and SRK); **HM**—headmaster (C.P.R.); **LLVs**—liquid line valves (KMS and SRK); **PM**—pump motor; **TXV**—thermostatic expansion valve; **WV**—inlet water valve

3. Controls and Adjustments

CAUTION

Dip switches are factory set. Failure to maintain factory settings may adversely affect performance and warranty coverage. For more information, contact Hoshizaki Technical Support at 1-800-233-1940.

a) Default Dip Switch Settings

The dip switches are factory set to the following positions:

S4 Dip Switch										
S4 Dip Switch No.	1	2	3	4	5	6	7	8	9	10
KMS-822MLH	OFF	OFF	OFF	ON	ON	ON	ON	OFF	OFF	ON

S5 Dip Switch (Do Not Adjust)					
S5 Dip Switch No.	1	2	3	4	5
KMS-822MLH	OFF	OFF	OFF	OFF	OFF

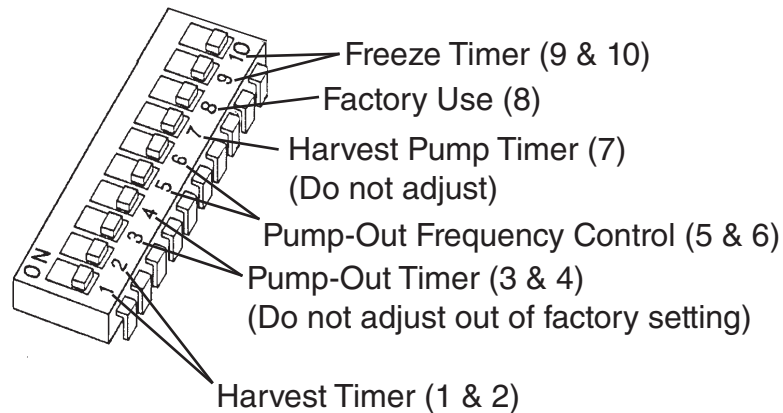

b) Harvest Timer (S4 dip switch 1 & 2)

The harvest timer starts when the thermistor reads 48°F (9°C) at the evaporator outlet and the control board reads the thermistor's 3.9 kΩ signal. The harvest timer is factory set, and generally no adjustment is required. However, a setting longer than the factory setting may be advised in cases where harvest needs to be prolonged for extra cleaning. Before changing this setting, contact your local Hoshizaki distributor or Hoshizaki Technical Support for recommendations. Keep in mind that setting the harvest timer to a longer setting decreases 24-hour production.

The pump-out timer (S4 dip switch 3 & 4) acts in place of the harvest timer during cycles with a pump-out. For details, see "II.C.3.c) Pump-Out Timer (S4 dip switch 3 & 4)."

S4 Dip Switch Setting		Time (seconds)
No. 1	No. 2	
OFF	OFF	60
ON	OFF	90
OFF	ON	120
ON	ON	180

c) Pump-Out Timer (S4 dip switch 3 & 4)

CAUTION

Factory set. Do not adjust. S4 dip switch 3 & 4 must remain in the factory default position of 3 off and 4 on. Otherwise, the drain valve will not energize during pump-out.

At the end of a freeze cycle when a pump-out is called for, the pump motor stops for 2 seconds, then the drain valve relay energizes, energizing the pump motor and drain valve. Water is removed from the bottom of the tank and sent down the drain. At the same time, water flows through the small float switch tube to power flush the float switch. The pump-out drains the water tank for the time determined by the pump-out timer. The pump-out timer also acts in place of the harvest timer during cycles with a pump-out. The pump-out timer is factory set, do not adjust.

Note: The drain valve shares power with the inlet water valve during the pump-out cycle. Therefore, S4 dip switch 3 & 4 must be set to 3 off and 4 on. See "III.B. Wiring Diagram."

S4 Dip Switch Setting		Time (seconds)		Inlet Water Valve
No. 3	No. 4	T1	T2	
OFF	OFF	10	150	closed
ON	OFF	10	180	closed
OFF	ON	10	120	open
ON	ON	20	180	closed

T1: Time to drain the water tank

T2: Harvest timer at pump-out

d) Pump-Out Frequency Control (S4 dip switch 5 & 6)

The pump-out frequency control is factory-adjusted to drain the water tank every 10 cycles, and generally no adjustment is required. However, where water quality is bad and the icemaker needs a pump-out more often, the pump-out frequency can be adjusted as shown in the table.

Timing of the first pump-out is dependent on S4 dip switch 5 & 6 settings. See the table below.

S4 Dip Switch Setting		Pump-Out Frequency	1st Pump-Out
No. 5	No. 6		
OFF	OFF	Every cycle	After 2nd freeze cycle
ON	OFF	Every 2 cycles	After 3rd freeze cycle
OFF	ON	Every 5 cycles	After 6th freeze cycle
ON	ON	Every 10 cycles	After 11th freeze cycle

e) Harvest Pump Timer (S4 dip switch 7)

CAUTION

Factory set for proper operation. Do not adjust. Adjustment outside of the factory default setting may result in damage to the icemaker.

Depending on the harvest pump timer setting, the pump motor energizes and runs the last 0 or 50 seconds of harvest. When the pump motor is on, water circulates over the evaporator. The water valve is open during harvest for a maximum of 6 minutes or the length of harvest minus 0 or 50 seconds (determined by the harvest pump timer setting), whichever is shorter. When S4 dip switch 7 is in the on position, the drain valve relay energizes through the control board K1 ten-pin connector pin #5 (DBu wire). The drain valve relay then energizes the pump motor for the last 50 seconds of harvest.

Note: The drain valve is not energized during the last 50 seconds of harvest because it shares power with the inlet water valve which de-energizes the last 50 seconds of harvest. See "III.B. Wiring Diagram."

S4 Dip Switch Setting		Pump Motor Time (seconds)
No. 7		
ON		50
OFF		0

f) Factory Use (S4 dip switch 8)

Factory set for proper operation. Do not adjust. This must be left in the factory default position.

g) Freeze Timer (S4 dip switch 9 & 10)

CAUTION

Adjust to proper specification, or the unit may not operate correctly.

The freeze timer setting determines the maximum allowed freeze time to prevent possible freeze-up issues. Upon termination of the freeze timer, the control board initiates the harvest cycle. After 2 consecutive freeze timer terminations, the control board shuts down the icemaker. In this case, see "IV.F.3. Low Ice Production" for possible solutions. The freeze timer is factory set, and generally no adjustment is required. Before changing this setting, contact your local Hoshizaki distributor or Hoshizaki Technical Support for recommendations.

S4 Dip Switch Setting		Time (minutes)
No. 9	No. 10	
OFF	OFF	60
OFF	ON	50
ON	OFF	70
ON	ON	60

h) Float Switch Control (S5 dip switch 1)

CAUTION

Factory set. Do not adjust. Otherwise, the unit will not operate correctly.

S5 dip switch 1 allows for single or double float switch applications. The KMS-822MLH uses a single float switch.

S5 Dip Switch Setting	Single or Double Float Switch Application
No. 1	
OFF	Single
On	Double

i) Refill Counter (S5 dip switch 2 through 5)

CAUTION

Factory set. Do not adjust. Otherwise, the unit will not operate correctly.

S5 dip switch 2 through 5 allows for refills during the freeze cycle. The KMS-822MLH does not refill.

D. Control Switch

The control switch has three positions: "OFF" for power off, "ICE" for icemaking, and "WASH" to activate the water pump when cleaning and sanitizing.

III. Technical Information

A. Water Circuit and Refrigeration Circuit

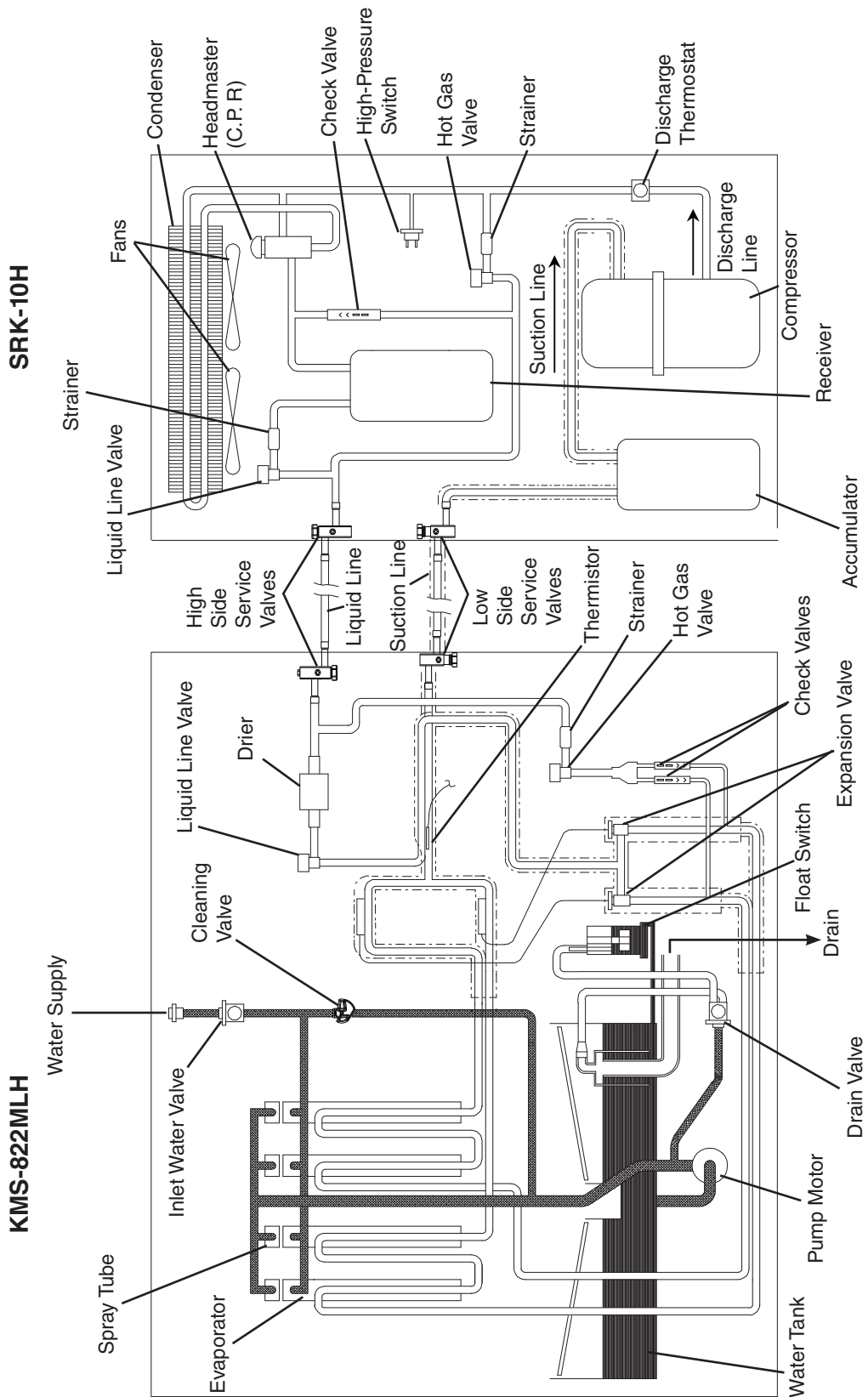

B. Wiring Diagram

1. KMS-822MLH with SRK-10H

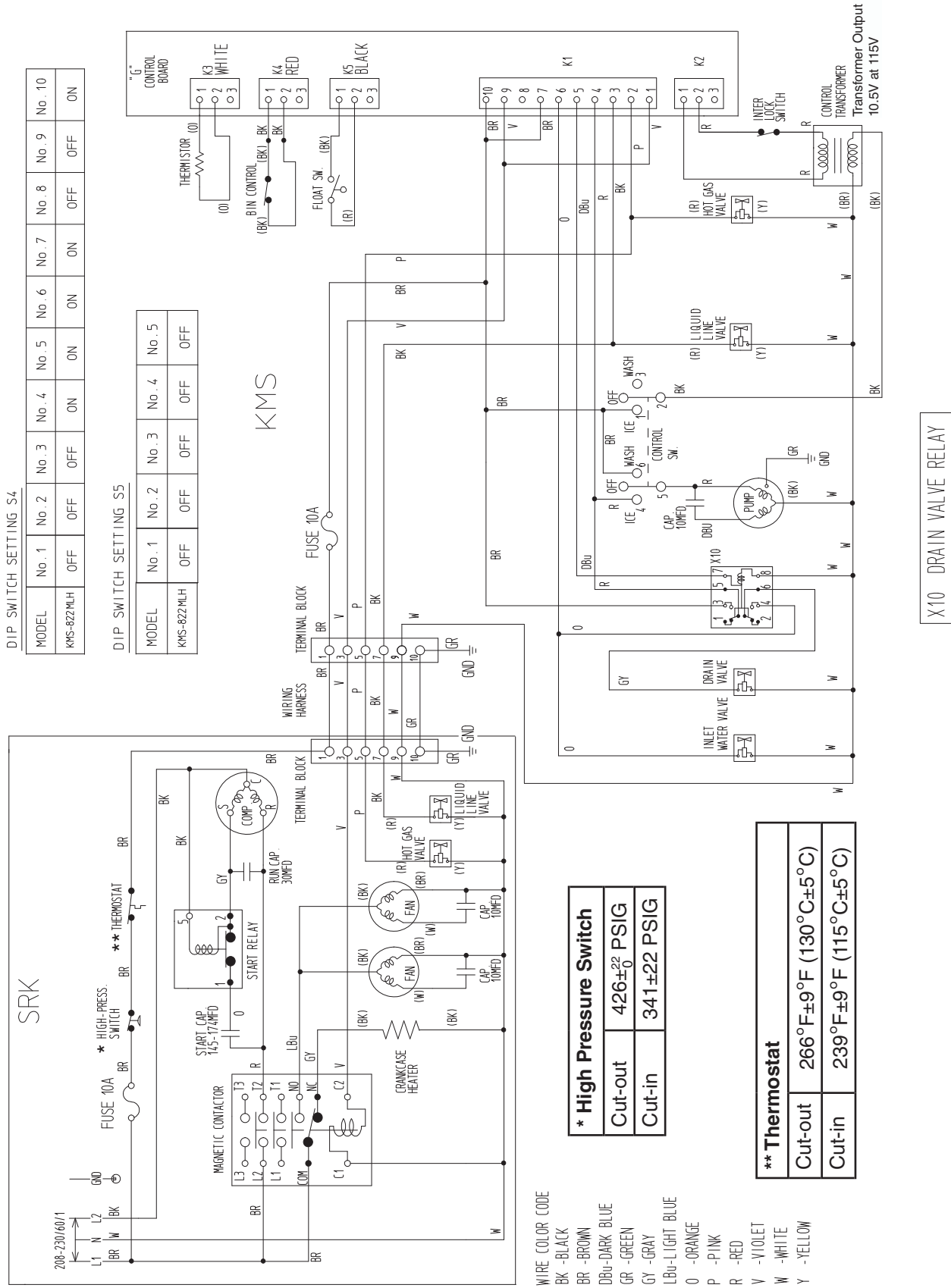

C. Performance Data

1. KMS-822MLH with SRK-10H

APPROXIMATE ICE PRODUCTION PER 24 HR.	AMBIENT TEMP. (°F/°C)	WATER TEMP. (°F/°C)					
		50/10		70/21		90/32	
	70/21	839	<u>381</u>	820	<u>372</u>	769	<u>349</u>
	80/27	824	<u>374</u>	795	<u>361</u>	730	<u>331</u>
	90/32	820	<u>372</u>	774	<u>351</u>	714	<u>324</u>
lbs./day <u>kg./day</u>	100/38	801	<u>364</u>	760	<u>345</u>	659	<u>299</u>
APPROXIMATE ELECTRIC CONSUMPTION	70/21	1710		1736		1749	
	80/27	1730		1771		1770	
	90/32	1736		1800		1805	
watts	100/38	1731		1801		1810	
APPROXIMATE WATER CONSUMPTION PER 24 HR.	70/21	363	<u>1.38</u>	301	<u>1.14</u>	267	<u>1.01</u>
	80/27	316	<u>1.19</u>	218	<u>0.83</u>	214	<u>0.81</u>
	90/32	301	<u>1.14</u>	149	<u>0.57</u>	132	<u>0.50</u>
gal./day <u>m³/day</u>	100/38	228	<u>0.86</u>	145	<u>0.55</u>	116	<u>0.44</u>
FREEZING CYCLE TIME	70/21	20		21		23	
	80/27	21		22		24	
	90/32	21		23		25	
min.	100/38	21		24		27	
HARVEST CYCLE TIME	70/21	3.9		3.4		3.2	
	80/27	3.6		2.8		2.8	
	90/32	3.4		2.2		2.2	
min.	100/38	2.9		2.2		2.1	
HEAD PRESSURE	70/21	179	<u>12.6</u>	192	<u>13.5</u>	211	<u>14.9</u>
	80/27	189	<u>13.3</u>	209	<u>14.7</u>	229	<u>16.1</u>
	90/32	192	<u>13.5</u>	223	<u>15.7</u>	243	<u>17.1</u>
PSIG <u>kg/cm²G</u>	100/38	196	<u>13.8</u>	228	<u>16.0</u>	262	<u>18.4</u>
SUCTION PRESSURE	70/21	36	<u>2.5</u>	37	<u>2.6</u>	43	<u>3.0</u>
	80/27	37	<u>2.6</u>	39	<u>2.8</u>	47	<u>3.3</u>
	90/32	37	<u>2.6</u>	41	<u>2.9</u>	48	<u>3.4</u>
PSIG <u>kg/cm²G</u>	100/38	40	<u>2.8</u>	43	<u>3.0</u>	54	<u>3.8</u>

TOTAL HEAT OF REJECTION FROM CONDENSER	16,200 BTU/h [AT 90°F (32°C) / WT 70°F (21°C)]
TOTAL HEAT OF REJECTION FROM COMPRESSOR	1,900 BTU/h [AT 90°F (32°C) / WT 70°F (21°C)]
CONDENSER VOLUME	226 CU. IN (SRK-10H)

Note:

1. Pressure data is recorded at 5 minutes into freezing cycle. The data not in **bold** should be used for reference only.
2. We reserve the right to make changes in specifications and design without prior notice.

IV. Service Diagnosis

WARNING

1. This unit should be diagnosed and repaired only by qualified service personnel to reduce the risk of death, electric shock, serious injury, or fire.
2. Risk of electric shock. Use extreme caution and exercise safe electrical practices.
3. Moving parts (e.g., fan blade) can crush and cut. Keep hands clear.
4. **CHOKING HAZARD:** Ensure all components, fasteners, and thumbscrews are securely in place after the unit is serviced. Make sure that none have fallen into the storage bin.
5. Make sure all food zones in the icemaker and dispenser unit/storage bin are clean after the unit is serviced. For cleaning procedures, see "VI. Cleaning and Maintenance."

A. Diagnostic Procedure

The diagnostic procedure is basically a sequence check which can be used at unit startup or for system diagnosis. This procedure allows you to diagnose electrical system and component failures. Before conducting the diagnostic procedure, check for correct installation, proper voltage per unit nameplate, and adequate water supply. Check CB using the steps in "IV.B. Control Board Check." Check the dip switch settings to assure that S4 dip switch 3, 4, 7, 8, 9, 10 and S5 dip switch 1 through 5 are in the factory default position. S4 dip switch 1, 2, 5, 6 are cleaning adjustments and the settings are flexible. For factory default settings, see "II.C.3.a) Default Dip Switch Settings." As you go through the procedure, check to assure the components energize and de-energize correctly. If not, those components and controls are suspect.

- 1) Turn off the power supply, then access the control box. Clear any ice from BC.
- 2) Turn on the power supply, then move the control switch to the "ICE" position. A 5-second delay occurs. The red "POWER OK" LED and green "BC CLOSED" LED on CB come on. If the yellow "BC OPEN" LED is on, check BC. See "IV.C.1. Bin Control Check."
- 3) **1-Minute Fill Cycle – LED 4 is on.** WV energizes. After 1 minute, CB checks for a closed F/S. If F/S is closed, harvest cycle begins. If closed, continue to step 4. If open, WV remains energized through additional 1-minute fill cycles until water fills the tank and closes F/S (low water safety). **Diagnosis:** Confirm that water is filling the water tank. If not, check that the water supply shut-off valve is open and WV screen and any external filters are clear. If WV does not energize (LED 4 on), check CB #6 pin (O wire) on CB K1 ten-pin connector for 115VAC. If no voltage is present, CB is bad and must be replaced. If voltage is present, check WV connections and solenoid continuity. If unit fails to start harvest, check for open F/S or bad 1-minute timer in CB. See "IV.D. Float Switch Check and Cleaning."
- 4) **Initial Harvest Cycle – LEDs 1, 4, and 2 are on.** WV remains energized, Comp, FMRs, and HGVs energize. CB monitors the warming of the evaporator via the thermistor located on the suction line. When the thermistor reaches 48°F (9°C), CB reads a 3.9 kΩ signal from the thermistor and turns harvest termination over to the harvest timer (S4 dip switch 1 & 2). The harvest timer has settings of 60, 90, 120, and

180 seconds. WV is energized during harvest for a maximum of 6 minutes or the length of harvest minus 50 seconds, whichever is shorter. 50 seconds before the harvest timer terminates, LED 4 goes off WV de-energizes, LED 3 comes on and DVR energizes, energizing PM for the last 50 seconds of harvest. **CAUTION! S4 dip switch 7 must remain in the factory default position of 7 on. Otherwise, PM will not energize during the last 50 seconds of harvest.** The minimum total time allowed by CB for a complete harvest cycle is 2 minutes. When the harvest timer terminates, the harvest cycle is complete. CB checks the position of F/S and proceeds to the next cycle if it is closed, or calls for a 1-minute fill cycle if it is open.

Diagnosis: Check that Comp, FMRs, and HGVs energize. WV is energized during harvest for a maximum of 6 minutes or the length of harvest minus 50 seconds (Harvest Pump Timer (S4 dip switch 7)), whichever is shorter. Average initial harvest cycle at factory setting is 2 to 3 minutes. 1.5 minutes after initial harvest begins, touch Comp discharge line. Is it hot? If not, check that Comp is energized, refrigerant pressures are in range, HGVs are energized and open, LLVs are de-energized and closed. If discharge line is hot, place a thermometer on the suction line next to the thermistor. Has it warmed to 48°F (9°C) or warmer? Confirm thermistor status. See "IV.E. Thermistor Check." If temperature has been reached, check that WV de-energizes (LED 4 off) and DVR energizes (LED 3 on), energizing PM to circulate water over evaporator for the last 50 seconds of harvest. If not, make sure CB S4 dip switch 7 is in the factory default position. Check CB K1 connector Pin #5 (DBu wire) and DVR solenoid for 115VAC. If 1-minute fill cycle starts after harvest, see "IV.D. Float Switch Check and Cleaning." If the thermistor reading is in proper range and CB fails to terminate the harvest cycle and initiate the freeze cycle, CB is bad and must be replaced.

- 5) **Freeze Cycle – LED 1 is on.** Comp, FMRs, and PM remain energized. LLVs energize, HGVs de-energize. The unit is held in freeze by a 5-minute short cycle protection timer (CB will not accept a signal from F/S during the first 5 minutes of freeze). After the 5-minute short cycle protection timer terminates, CB turns freeze termination over to F/S. **Diagnosis:** Check that Comp, FMRs, and PM continue. Confirm that evaporator temperature drops. If not, confirm that LLVs have energized and are open. Make sure WV and HGVs are de-energized and closed. Next, confirm proper unit pressures and TXV operation, check for an inoperative HM, or an inefficient Comp. After 5 minutes in freeze, disconnect black F/S connector from CB BLACK K5 connector. After a 15 second delay, the unit should switch out of the freeze cycle. If the unit switches out of freeze with F/S connector removed, but would previously not switch out of freeze with F/S connected (long freeze - 3 beep alarm), F/S may be sticking. To check and clean F/S, see "IV.D. Float Switch Check and Cleaning." If the unit remains in freeze longer than 15 seconds after disconnecting black F/S connector, replace CB. For short freeze cycle, check that reservoir is full at beginning of freeze, DV is de-energized and closed, and drain plug and stand pipe are in and not leaking.

Note: Normal freeze cycle will last 20 to 40 minutes depending on model and conditions. Cycle times and pressures should follow performance data provided in this manual. See "III.C. Performance Data."

6) **Pump-Out Cycle – (10 second pump-out) – LEDs 1, 4, 3, and 2 are on.** LED 4 (WV circuit) is on when S4 dip switch 3 & 4 are set to factory default positions of 3 off and 4 on. With S4 dip switch 3 off & 4 on, CB energizes WV during pump-out. The WV circuit energizes DV through DVR during pump-out cycles. **CAUTION! Do not adjust. S4 dip switch 3 & 4 must remain in the factory default position of 3 off and 4 on. Otherwise, DV will not energize during pump-out.** Comp and FMRs remain energized, WV and HGVs energize, LLVs de-energize. PM stops for 2 seconds, then DVR and WV energize, energizing PM and DV for 10 seconds. When the pump-out timer terminates, pump-out is complete. The pump-out frequency control is factory set for every 10th cycle, and generally no adjustment is required. However, where water quality is bad and the icemaker needs a pump-out more often, the pump-out frequency can be adjusted as shown in the table. Timing of the first pump-out is dependent on S4 dip switch 5 & 6 settings. See the table below.

S4 Dip Switch Setting		Pump-Out Frequency	1st Pump-Out
No. 5	No. 6		
OFF	OFF	Every cycle	After 2nd freeze cycle
ON	OFF	Every 2 cycles	After 3rd freeze cycle
OFF	ON	Every 5 cycles	After 6th freeze cycle
ON	ON	Every 10 cycles	After 11th freeze cycle

Diagnosis: Confirm CB S4 dip switch 3 & 4 settings are in the factory default positions (3 off and 4 on). Check that Comp continues. Confirm WV and HGVs energize and LLVs de-energize. Next, check that DVR, PM, and DV energize. If DVR does not energize (LED 3 on), check CB #5 pin (DBu wire) on CB K1 ten-pin connector for 115VAC. If no voltage is present CB is bad and must be replaced. If 115VAC is present and DVR is not energized, check DVR solenoid for open windings. If DVR is energized and PM is not energized, check PM circuit (including DVR contacts), PM, and PM capacitor. If water is not going down the drain, check that DV is energized and open. If not, check that CB LEDs 4 and 3 are on and WV circuit energizes DV during pump-out. Check for 115VAC at DV solenoid and make sure DV is clear of debris. If water does not pump out, check and clean DV and tubing.

7) **Normal Harvest Cycle** – same as the initial harvest cycle – Return to "IV.A.4) Initial Harvest Cycle."

8) **Shutdown**

Bin Control:

See "IV.C.1. Bin Control Check."

Legend: **BC**–bin control; **CB**–control board; **Comp**–compressor; **DV**–drain valve; **DVR**–drain valve relay; **FMRs**–fan motors-remote; **F/S**–float switch; **HGVs**–hot gas valves (KMS and SRK); **HM**–headmaster (C.P.R.); **LLVs**–liquid line valves (KMS and SRK); **PM**–pump motor; **TXV**–thermostatic expansion valve; **WV**–inlet water valve

B. Control Board Check

Before replacing CB that does not show a visible defect and that you suspect is bad, always conduct the following check procedure. This procedure will help you verify your diagnosis.

Alarm Reset: If CB is in alarm (beeping), press the "ALARM RESET" button on CB while CB is beeping. **WARNING! Risk of electric shock. Care should be taken not to touch live terminals.** Once reset, the unit starts at the 1-minute fill cycle. For audible alarm information, see "II.C.2. LED Lights and Audible Alarm Safeties."

- 1) Check the dip switch settings to assure that S4 dip switch 3, 4, 7, 8, 9, 10, and S5 dip switch 1 through 5 are in the factory default position. S4 dip switch 1, 2, 5, 6 are cleaning adjustments and the settings are flexible. For factory default settings, see "II.C.3.a) Default Dip Switch Settings."
- 2) Move the control switch to the "ICE" position. If the red "POWER OK" LED is on, control voltage is good, continue to step 3. If the red "POWER OK" LED is off, check CT secondary circuit. CT output is 10.5VAC at 115VAC primary input. If the secondary circuit has proper voltage and the red LED is off, CB is bad and should be replaced.

If the secondary circuit does not have proper voltage, check CT primary circuit. Check for 115VAC at CB K1 ten-pin connector #10 pin (BR wire) to a white neutral wire for 115VAC. (Always choose a white neutral wire to establish a good neutral connection when checking voltages.) For additional checks, see "IV.F.1. No Ice Production."
- 3) The "OUTPUT TEST" button provides a relay sequence test. Make sure the control switch is in the "ICE" position, then press the "OUTPUT TEST" button. The correct lighting sequence is 1, 4, 3, 2. Note that the order of the LEDs from the outer edge of the control board is 1, 4, 3, 2. Components (e.g., compressor) will cycle during the test. Following the test, the icemaker begins operation at the 1-minute fill cycle. If the LEDs do not light as described above, CB is bad and should be replaced.
- 4) To verify voltage output from CB to the components, slide the CB K1 ten-pin connector out far enough to allow multimeter lead contact. With the unit in the cycle to be tested, check output voltage from the corresponding pin on CB K1 ten-pin connector to ground. If output voltage is not found and the appropriate LED is on, CB is bad and should be replaced.

Legend: **CB**—control board; **CT**—control transformer

C. Bin Control Check and Cleaning

This unit uses a BC with a lever-actuated proximity switch to control the ice level in the storage bin. No adjustment is required. BC is connected to CB red K4 connector. When calling for ice, BC proximity switch is closed (green "BC CLOSED" LED on). When BC actuator paddle is engaged, BC proximity switch opens (yellow "BC OPEN" LED on) and CB shuts down the unit according to the chart below.

Cycle at Mechanical Bin Control Activation	Shutdown
Fill Cycle	15 seconds after activation.
Harvest Cycle	At the end of the harvest cycle, or up to 15 seconds into the freeze cycle if activated at the end of the harvest cycle.
Freeze Cycle	15 seconds after activation if activated at least 15 seconds before the 5-minute short cycle protection timer terminates. Otherwise, at the end of the next harvest cycle.

1. Bin Control Check

To check BC, follow the steps below.

- 1) Turn off the power supply and clear any ice away from BC.
- 2) Remove the front panel, top panel, and right side panel, then move the control switch to the "OFF" position.
- 3) Remove the control box cover.
- 4) Disconnect the red BC connector from CB RED K4 connector.
- 5) If BC is accessible from the dispenser unit/storage bin, continue to step 7. If BC is not accessible from the dispenser unit/storage bin, follow the instructions below to remove BC.
 - a. Loosen the screws securing the control box, then lift the control box off and hang it from the base. See Fig. 1.
 - b. Remove the insulation. Remove the thumbscrews securing the bin control assembly, then remove the bin control assembly.
- 6) Check for continuity across the wires of the red connector. When the actuator paddle is not engaged, BC switch is closed. If open, check that BC cable connector is properly connected and that the actuator paddle is not sticking. Clean if necessary. See "IV.C.2. Bin Control Cleaning." If BC switch still reads open, replace BC.
- 7) Press the actuator paddle, check for continuity across the wires of the red connector. When the actuator paddle is engaged, BC switch is open. If closed, check that the actuator paddle is not restricted. Clean if necessary. See "IV.C.2. Bin Control Cleaning." If BC switch still reads closed, replace BC.
- 8) If the control box was removed, replace it in its correct position.
- 9) Reconnect the red connector to CB RED K4 connector, then move the control switch to the "ICE" position.
- 10) Turn on the power supply.
- 11) Check that the green "BC CLOSED" LED on CB is on.

- 12) Allow the unit to cycle on. Press and hold the actuator paddle. The yellow "BC OPEN" LED should be on and the unit should shut down according to the chart above. If it does not, CB is bad and should be replaced.
- 13) Turn off the power supply.
- 14) If BC was removed, remove the control box and then replace BC and control box in their correct positions.
- 15) Replace the control box cover.
- 16) Replace the panels in their correct positions.
- 17) Turn on the power supply to start the automatic icemaking process.

Legend: **BC**—bin control; **CB**—control board

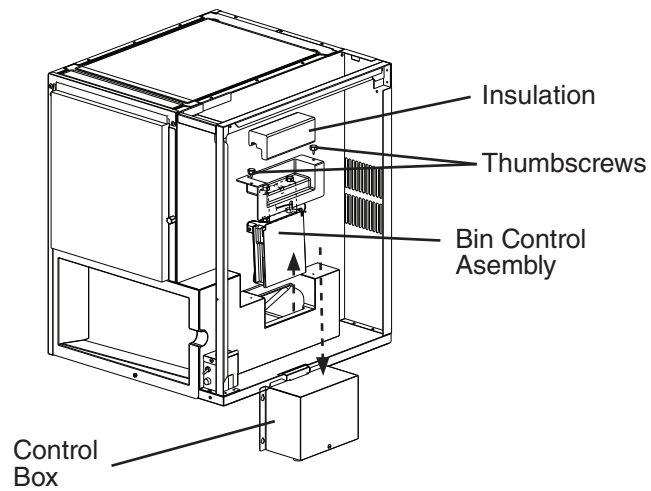

Fig. 1

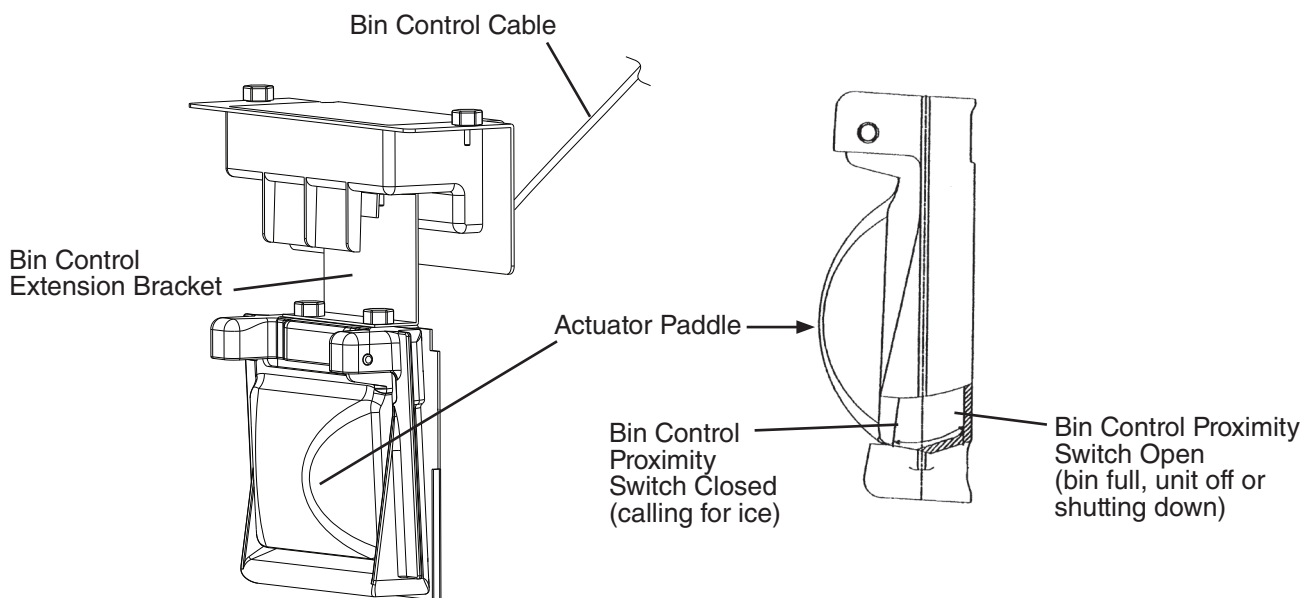

Fig. 2

2. Bin Control Cleaning

Scale may build up on BC. Scale can cause the actuator paddle and magnet to stick. In this case, BC should be cleaned.

⚠ WARNING

CHOKING HAZARD: Ensure all components, fasteners, and thumbscrews are securely in place after the unit is serviced. Make sure that none have fallen into the storage bin.

- 1) Turn off the power supply and clear any ice away from BC.
- 2) Remove the front panel, top panel, and right side panel, then move the control switch to the "OFF" position.
- 3) Remove the control box cover.
- 4) Disconnect the red BC connector from CB RED K4 connector.
- 5) Follow the instructions below to remove BC.
 - a. Loosen the screws securing the control box, then lift the control box off and hang it from the base. See Fig. 1.
 - b. Remove the insulation. Remove the thumbscrews securing the bin control assembly. Remove the bin control assembly.
- 6) Remove BC from the extension bracket. See Fig. 3.
- 7) Wipe down BC assembly with a mixture of 1 part Hoshizaki "Scale Away" and 25 parts warm water. Rinse the parts thoroughly with clean water.
- 8) Reassemble BC assembly and replace it in its correct position.

Note: If the magnet was removed for cleaning, be sure to replace it in its correct position.
- 9) Replace the control box in its correct position and secure, then reconnect the red BC connector to CB RED K4 connector.
- 10) Replace the control box cover.
- 11) Move the control switch to the "ICE" position.
- 12) Replace the panels in their correct positions.
- 13) Turn on the power supply to start the automatic icemaking process.

Legend: **BC**—bin control

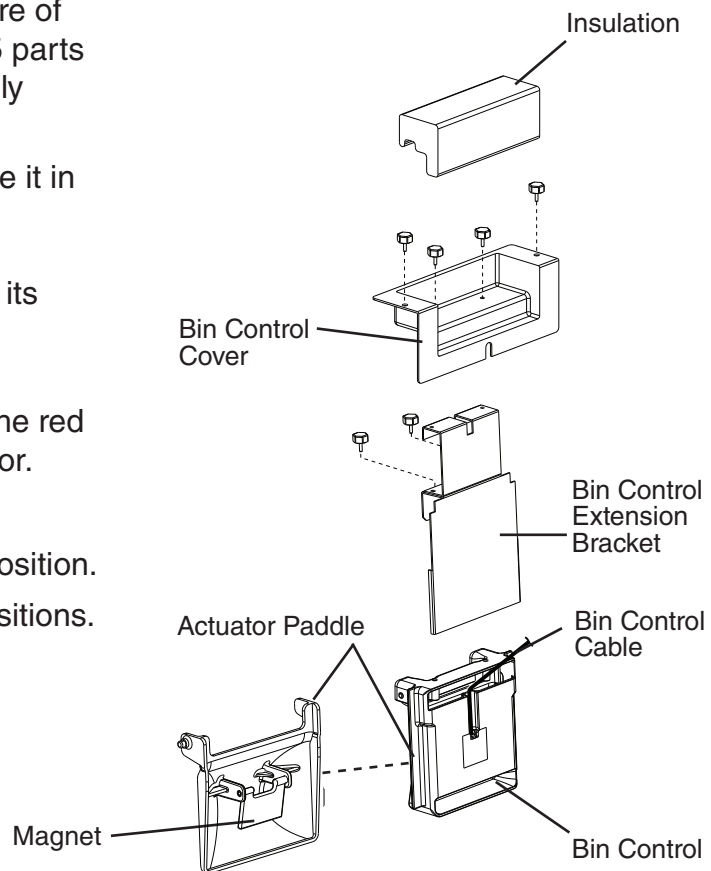

Fig. 3

D. Float Switch Check and Cleaning

F/S is used to determine that there is sufficient water in the tank after the 1-minute fill cycle and after each harvest cycle. F/S is also used to determine that the appropriate volume of water has been converted into ice before switching out of the freeze cycle. No adjustment is required.

1. Float Switch Check

To check F/S, follow the steps below.

- 1) Turn off the power supply.
- 2) Remove the front panel, then move the control switch to the "OFF" position.
- 3) Remove the insulation panel. Remove cube guide B, then remove cube guide A. See Fig. 4. Remove the overflow cap, overflow pipe, and water shield.
- 4) Remove the drain plug. Allow the water tank to drain, then replace the drain plug in its correct position. Be careful not to cross thread it.
- 5) Replace the water shield, overflow pipe, overflow cap, cube guide A, cube guide B, and insulation panel in their correct positions. Be careful not to cross thread the overflow pipe.
- 6) Remove the right side panel, then remove the control box cover.
- 7) Disconnect the black float switch connector from the control board BLACK K5 connector.
- 8) Check for continuity across F/S leads. With the water tank empty, F/S should be open. If open, continue to step 9. If closed, follow the steps in "IV.D.2. Float Switch Cleaning." After cleaning the float switch, check it again. Replace if necessary.
- 9) Reconnect the black F/S connector to CB BLACK K5 connector, then replace the control box cover and right side panel in their correct positions.
- 10) Move the control switch to the "ICE" position. Replace the insulation panel and the front panel in their correct positions, then turn on the power supply. After 1 minute, the 1-minute fill cycle should end and the initial harvest cycle should begin. If the initial harvest cycle begins, F/S is good and the check is complete. If the initial harvest cycle does not begin, continue to step 11.
- 11) Turn off the power supply.
- 12) Remove the front panel, then move the control switch to the "OFF" position.
- 13) Remove the right side panel, then remove the control box cover.
- 14) Disconnect the black F/S connector from CB BLACK K5 connector.

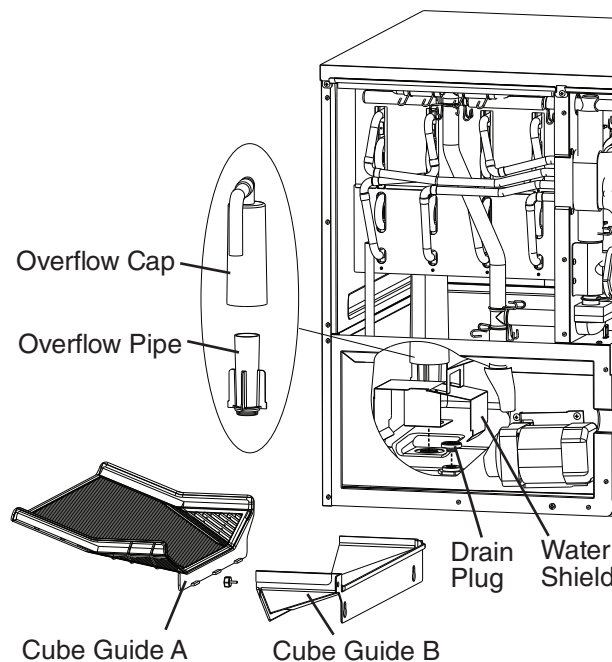

Fig. 4

- 15) Check for continuity across F/S leads. With the water tank full, F/S should be closed. If F/S is closed and the icemaker will not switch from the 1-minute fill cycle to the initial harvest cycle, replace CB.

If open, confirm that the water tank is full. If the tank is not full, check the water supply, water filters, and inlet water valve. If the tank is full, follow the steps in "IV.D.2. Float Switch Cleaning." After cleaning the float switch, check it again. Replace if necessary.

2. Float Switch Cleaning

Depending on local water conditions, scale may build up on the float switch. Scale on the switch can cause the float to stick. In this case, the float switch should be cleaned.

- 1) Turn off the power supply.
- 2) Remove the front panel, then move the control switch to the "OFF" position.
- 3) Remove the insulation panel. Remove cube guide B, then remove cube guide A. See Fig. 4. Remove the overflow cap, overflow pipe, and water shield.
- 4) Remove the drain plug. Allow the water tank to drain, then replace the drain plug in its correct position. Be careful not to cross thread it.
- 5) Replace the water shield, overflow pipe, overflow cap, cube guide A, cube guide B, and insulation panel in their correct positions. Be careful not to cross thread the overflow pipe.
- 6) Disconnect the vent tube and the flush tube from the top of the float switch, then remove the float switch assembly from the mounting bracket and remove the rubber boot from the bottom of the float switch assembly. See Fig. 5.
- 7) Remove the retainer rod from the bottom of the float switch assembly, then remove the float. Be careful not to bend the retainer rod excessively when removing it.
- 8) Wipe down the float switch assembly's housing, shaft, float, and retainer rod with a mixture of 1 part Hoshizaki "Scale Away" and 25 parts warm water. Clean the inside of the rubber boot and hose with cleaning solution. Rinse the parts thoroughly with clean water.
- 9) Reassemble the float switch assembly and replace it and the rubber boot in their correct positions. Reconnect the vent tube and the flush tube.
- 10) Move the control switch to the "ICE" position.
- 11) Replace the front panel in its correct position.
- 12) Turn on the power supply to start the automatic icemaking process.

Legend: **CB**—control board; **F/S**—float switch

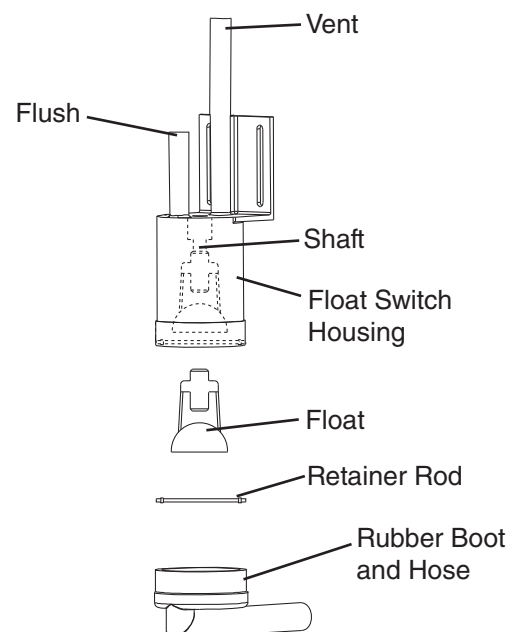

Fig. 5

E. Thermistor Check

To check thermistor resistance, follow the steps below.

- 1) Turn off the power supply.
- 2) Remove the front panel, then move the control switch to the "OFF" position.
- 3) Remove the right side panel, then remove the control box cover.
- 4) Remove the thermistor.
- 5) Immerse the thermistor sensor portion in a glass containing ice and water for 2 or 3 minutes.
- 6) Disconnect the white thermistor connector from CB WHITE K3 connector and check the resistance between thermistor leads. Normal reading is within 4.7 to 6.2 k Ω . If outside the normal reading, replace the thermistor. See "V.B. Important Notes for Component Replacement." If inside the normal reading, continue to the next step.
- 7) Replace the thermistor in its correct position. See "V.B. Important Notes for Component Replacement."
- 8) Reconnect the white thermistor connector to CB WHITE K3 connector.
- 9) Replace the control box cover in its correct position, then turn on the power supply.
- 10) Move the control switch to the "ICE" position.
- 11) Once the harvest cycle starts, begin timing the harvest cycle.
- 12) The harvest timer and harvest cycle should terminate within 2 to 5 minutes. If the harvest cycle does not terminate within 2 to 5 minutes, the harvest timer is bad and CB should be replaced.

Legend: **CB**—control board

F. Diagnostic Charts

Before consulting the diagnostic charts, check for correct installation, proper voltage per unit nameplate, and adequate water supply. Check CB using the steps in "IV.B. Control Board Check." Check the dip switch settings to assure that S4 dip switch 3, 4, 7, 8, 9, 10, and S5 dip switch 1 through 5 are in the factory default position. S4 dip switch 1, 2, 5, 6 are cleaning adjustments and the settings are flexible. For factory default settings, see "II.C.3.a) Default Dip Switch Settings."

1. No Ice Production

No Ice Production - Possible Cause	
1. Power Supply	a) Off, blown fuse, or tripped breaker.
	b) Not within specifications.
2. Water Supply	a) Water supply off or improper water pressure.
	b) External water filters clogged.
3. Fuse (SRK Control Box)	a) Blown.
4. High-Pressure Switch (SRK)	a) Dirty condenser.
	b) Condensing unit fan not operating.
	c) Headmaster (C.P.R.) open.
	d) Refrigerant overcharged.
	e) Bad contacts.
	f) Refrigerant lines or components plugged.
5. Thermostat (SRK)	a) Ambient temperature too warm.
	b) Compressor or compressor components faulty.
	c) Defective.
	d) Hot gas valve open.
	e) Dirty condenser.
	f) Condensing unit fan not operating.
6. Wire Harness	a) Disconnected or loose connection.
7. Fuse (KMS Switch Box)	a) Blown.
8. Control Switch	a) In "WASH" or "OFF" position.
	b) Bad contacts.
9. Control Transformer (115V/10.5V)	a) Coil winding open or shorted.
10. Interlock Switch (Cleaning Valve)	a) In open (vertical) position.
	b) Bad contacts.
11. Control Board See "IV.B. Control Board Check"	a) In alarm.
	b) BC OPEN, yellow LED on (bin full).
	c) Defective.
12. Bin Control See "IV.C. Bin Control Check and Cleaning"	a) Tripped with bin filled with ice.
	b) Actuator does not move freely.
	c) Defective.
13. Inlet Water Valve	a) Screen or orifice clogged.
	b) Coil winding open.
	c) Open in freeze cycle.

No Ice Production - Possible Cause	
14. Float Switch See "IV.D. Float Switch Check and Cleaning"	a) Float does not move freely.
	b) Defective.
15. Compressor	a) Magnetic contactor contacts bad or coil winding open.
	b) Start capacitor or run capacitor defective.
	c) Internal overload protector open.
	d) Start relay contacts bad or coil winding open.
	e) Protector tripped.
	f) Compressor defective.
16. Hot Gas Valves (KMS & SRK)	a) Closed in harvest cycle.
	b) Open in freeze cycle.
17. Thermistor See "IV.E. Thermistor Check"	a) Loose, disconnected, or defective.
18. Pump Motor	a) Motor winding open.
	b) Bearing worn out or locked rotor.
	c) Defective capacitor.
	d) Mechanical seal worn out.
19. Expansion Valve (TXV)	a) Bulb loose.
	b) Operating erratically.
20. Liquid Line Valves (KMS & SRK)	a) Closed in freeze cycle.
	b) Open in harvest cycle.
21. Condensing Unit Fan Motor	a) Motor winding open.
	b) Bearing worn out or locked rotor.
	c) Defective capacitor.
22. Headmaster (C.P.R.)	a) Defective.
23. Drain Valve Relay	a) Bad contacts (closed). Pump motor runs constantly.
	b) Defective coil.
24. Drain Valve	a) Dirty, leaking by.
	b) Defective coil.
25. Water System	a) Water leaks causing short freeze time.

2. Freeze-Up

Defrost and clean the unit prior to diagnosing freeze up. See "VI.A. Cleaning and Sanitizing Instructions." Fill out a Hoshizaki freeze up checklist.

Freeze Up - Possible Cause	
Harvest Cycle	
1. Evaporator	a) Scaled up.
	b) Damaged.
2. Cube Guides	a) Out of position.
3. Spray Tubes and/or Spray Guides	a) Dirty.
	b) Out of position.
4. Water Supply	a) Low water pressure.
	b) External water filters clogged.
	c) Insufficient water line size. Minimum 1/4" nominal ID.
5. Inlet Water Valve	a) Screen or orifice clogged.

Freeze Up - Possible Cause	
6. Float Switch See "IV.D. Float Switch Check and Cleaning"	a) Dirty, sticking.
	b) Defective.
7. Refrigerant Charge	a) Low.
8. Control Board See "II.C.2. Controls and Adjustments" and "IV.B. Control Board Check"	a) Harvest timer (S4 dip switch 1 & 2) set too short.
	b) Harvest pump timer (S4 dip switch 3 & 4) not in factory default position.
	c) Defective.
9. Bin Control See "IV.C. Bin Control Check and Cleaning"	a) Actuator does not move freely.
10. Thermistor See "IV.E. Thermistor Check"	a) Loose, disconnected, or defective.
11. Expansion Valve (TXV)	a) Defective.
12. Hot Gas Valves (KMS & SRK)	a) Closed.
13. Liquid Line Valves (KMS & SRK)	a) Open.
14. Drain Valve Relay	a) Bad contacts. Open coil. Not allowing pump motor operation during last 50 seconds of harvest.
Freeze Cycle	
1. Evaporator	a) Scaled up.
	b) Damaged.
2. Spray Tubes and/or Spray Guides	a) Dirty.
	b) Out of position.
3. Refrigerant charge	a) Low.
4. Control Board See "IV.B. Control Board Check"	a) Freeze timer set incorrectly.
	b) Defective.
5. Inlet Water Valve	a) Leaking by.
6. Float Switch See "IV.D. Float Switch Check and Cleaning"	a) Float does not move freely.
	b) Defective.
7. Pump Motor	a) RPM too slow.
8. Expansion Valve (TXV)	a) Bulb loose or Defective.
9. Headmaster (C.P.R.)	a) Defective.

3. Low Ice Production

Low Ice Production - Possible Cause	
Long Harvest Cycle	
1. Evaporator	a) Scaled up.
2. Spray Tubes and/or Spray Guides	a) Dirty.
	b) Out of position.
3. Refrigerant Charge	a) Low.
4. Water Supply	a) Low water pressure.
	b) External water filters clogged.
	c) Insufficient water line size. Minimum 1/4" nominal ID.
	d) Too cold.
5. Control Board See "IV.B. Control Board Check"	a) Thermistor connection loose (K3).
	b) Defective.
6. Thermistor See "IV.E. Thermistor Check"	a) Loose, disconnected, or defective.
7. Hot Gas Valves (KMS & SRK)	a) Erratic or closed in harvest.
8. Inlet Water Valve	a) Screen or orifice clogged.
9. Compressor	a) Inefficient or off.
10. Liquid Line Valves (KMS & SRK)	a) Erratic or open in harvest.
11. Expansion Valve (TXV)	a) Defective.
12. Headmaster (C.P.R.)	a) Defective.
Long Freeze Cycle	
1. Evaporator	a) Scaled up, dirty.
2. Float Switch See "IV.D. Float Switch Check and Cleaning"	a) Scaled up, dirty.
	b) Float sticking.
	c) Defective switch.
3. Inlet Water Valve	a) Leaking by.
4. Hot Gas Valves (KMS & SRK)	a) Erratic or open in freeze.
5. Condenser	a) Clogged.
6. Control Board See "IV.B. Control Board Check"	a) Float switch connection loose (K5).
	b) Defective.
7. Refrigerant Charge	a) Low.
8. Expansion Valve (TXV)	a) Bulb loose.
	b) Defective.
9. Compressor	a) Inefficient or off.
10. Pump Motor	a) RPM too slow.
11. Liquid Line Valves (KMS & SRK)	a) Erratic or closed.
12. Headmaster (C.P.R.)	a) Not bypassing.

V. Replacement of Components

⚠ WARNING

1. This unit should be diagnosed and repaired only by qualified service personnel to reduce the risk of death, electric shock, serious injury, or fire.
2. Move the control switch to the "OFF" position and turn off the power supply before servicing. Lockout/Tagout to prevent the power from being turned back on inadvertently.
3. **CHOKING HAZARD:** Ensure all components, fasteners, and thumbscrews are securely in place after the unit is serviced. Make sure that none have fallen into the storage bin.
4. Make sure all food zones in the icemaker and storage bin are clean after the unit is serviced. For cleaning procedures, see "VI. Cleaning and Maintenance."

A. Service for Refrigerant Lines

⚠ WARNING

1. Repairs requiring the refrigeration circuit to be opened must be performed by properly trained and EPA-certified service personnel.
2. Always recover the refrigerant and store it in an approved container. Do not discharge the refrigerant into the atmosphere.
3. Use an electronic leak detector or soap bubbles to check for leaks. Add a trace of refrigerant to the system (if using an electronic leak detector), and then raise the pressure using nitrogen gas (140 PSIG). DO NOT use R-404A as a mixture with pressurized air for leak testing.

CAUTION

1. Do not leave the system open for longer than 15 minutes when replacing or servicing parts. The Polyol Ester (POE) oils used in R-404A units can absorb moisture quickly. Therefore it is important to prevent moisture from entering the system when replacing or servicing parts.
2. Always install a new drier every time the sealed refrigeration system is opened.
3. Do not replace the drier until after all other repair or replacement has been made. Install the new drier with the arrow on the drier in the direction of the refrigerant flow.
4. When brazing, protect the drier by using a wet cloth to prevent the drier from overheating. Do not allow the drier to exceed 250°F (121°C).

1. Refrigerant Recovery

The icemaker is provided with refrigerant service valves. Using proper refrigerant practices, recover the refrigerant from the service valves and store it in an approved container. Do not discharge the refrigerant into the atmosphere.

2. Brazing

⚠ WARNING

1. R-404A itself is not flammable at atmospheric pressure and temperatures up to 176°F (80°C).
2. R-404A itself is not explosive or poisonous. However, when exposed to high temperatures (open flames), R-404A can be decomposed to form hydrofluoric acid and carbonyl fluoride both of which are hazardous.
3. Do not use silver alloy or copper alloy containing arsenic.
4. Use an electronic leak detector or soap bubbles to check for leaks. Add a trace of refrigerant to the system (if using an electronic leak detector), and then raise the pressure using nitrogen gas (140 PSIG). DO NOT use R-404A as a mixture with pressurized air for leak testing.

- 1) Braze all fittings while purging with nitrogen gas flowing at a pressure of 3 to 4 PSIG.

Note: Because the pipes in the evaporator case are specially coated to resist corrosion, it is important to make connections outside the evaporator case when possible. If it is necessary to braze inside the evaporator case, use sandpaper to remove the coating from the brazing connections before unbrazing the components.

⚠ CAUTION

1. Always install a new drier every time the sealed refrigeration system is opened.
2. Do not replace the drier until after all other repair or replacement has been made. Install the new drier with the arrow on the drier in the direction of the refrigerant flow.
3. When brazing, protect the drier by using a wet cloth to prevent the drier from overheating. Do not allow the drier to exceed 250°F (121°C).

- 2) Use an electronic leak detector or soap bubbles to check for leaks. Add a trace of refrigerant to the system (if using an electronic leak detector), and then raise the pressure using nitrogen gas (140 PSIG). DO NOT use R-404A as a mixture with pressurized air for leak testing.

3. Evacuation and Recharge (R-404A)

- 1) Attach a vacuum pump to the system. Be sure to connect the charging hoses to both high and low-side service valves.

⚠ IMPORTANT

The vacuum level and vacuum pump may be the same as those for current refrigerants. However, the rubber hose and gauge manifold to be used for evacuation and refrigerant charge should be exclusively for POE oils.

- 2) Turn on the vacuum pump. Open the gauge manifold valves, then open the high and low-side service valves. Never allow the oil in the vacuum pump to flow backwards.
- 3) Allow the vacuum pump to pull down to a 29.9" Hg vacuum. Evacuating period depends on pump capacity.

- 4) Close the low-side valve and high-side valve on the gauge manifold.
- 5) Disconnect the gauge manifold hose from the vacuum pump and attach it to a refrigerant service cylinder. Remember to loosen the connection and purge the air from the hose. See the nameplate on the SRK for the required refrigerant charge. Hoshizaki recommends only virgin refrigerant or reclaimed refrigerant which meets ARI Standard 700 (latest edition) be used.
- 6) A liquid charge is required when charging an R-404A system (to prevent fractionation). Place the service cylinder on the scales; if the service cylinder is not equipped with a dip tube, invert the service cylinder, then place it on the scales. Open the high-side valve on the gauge manifold.
- 7) Allow the system to charge with liquid until the proper charge weight is met.
- 8) If necessary, add any remaining charge to the system through the low-side.
CAUTION! To prevent compressor damage, use a throttling valve or liquid dispensing device to add the remaining liquid charge through the low-side service valve with the unit running.
- 9) Close the high and low-side service valves. Close the high and low-side gauge manifold valves, then disconnect the gauge manifold hoses.
- 10) Cap the service valves to prevent a possible leak.

B. Important Notes for Component Replacement

CAUTION

When replacing a component listed below, see the notes to help ensure proper operation.

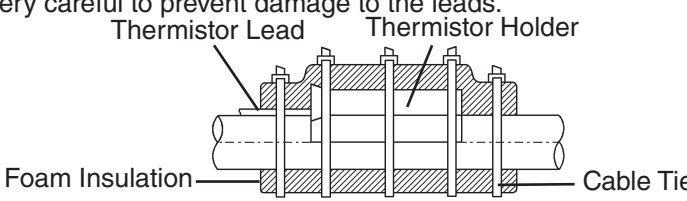
Component	Notes
Compressor	Install a new start capacitor, run capacitor, and start relay.
Expansion Valve	<ul style="list-style-type: none"> • Attach the expansion valve bulb to the suction line in the same location as the previous bulb. • The bulb should be between the 10 and 2 o'clock positions on the tube. • Secure the bulb with the clamp and holder, then insulate it.
Hot Gas Valves Liquid Line Valves	<ul style="list-style-type: none"> • Replace the strainer when replacing a hot gas valve. • Use copper tube of the same diameter and length when replacing valve lines.
Fan Motor	Install a new capacitor.
Pump Motor	Install a new capacitor.
Thermistor	<ul style="list-style-type: none"> • Attach the new thermistor to the suction line in the same location as the previous thermistor. • The thermistor should be at the 12 o'clock position on the tube. • Smoothly fill the recessed area of the thermistor holder with high thermal conductive type sealant. Hoshizaki America part number 4A0683-01 (Silicone Heat Sink Compound 10-8108 manufactured by GC Electronics), KE-4560 RTV (manufactured by ShinEtsu Silicones), or equivalent are recommended. • Secure the thermistor with the holder, then insulate it. • Be very careful to prevent damage to the leads. <div style="text-align: center; margin-top: 10px;">  </div>

VI. Cleaning and Maintenance

This icemaker must be cleaned and maintained in accordance with the instruction manual and labels provided with the icemaker. Consult with your local distributor about cleaning and maintenance service. To obtain the name and phone number of your local distributor, visit www.hoshizaki.com or call Hoshizaki Technical Support at 1-800-233-1940 in the USA.

WARNING

1. Except as specified below, only qualified service technicians should attempt to service this icemaker.
2. **CHOKING HAZARD:** Ensure all components, fasteners, and thumbscrews are securely in place after any cleaning or maintenance is done to the unit. Make sure that none have fallen into the dispenser unit/storage bin.
3. The dispenser unit/storage bin is for ice use only. Do not store anything else in the dispenser unit/storage bin.

A. Cleaning and Sanitizing Instructions

Hoshizaki recommends cleaning and sanitizing this unit at least once a year. More frequent cleaning and sanitizing, however, may be required in some existing water conditions.

WARNING

1. To prevent injury to individuals and damage to the icemaker, do not use ammonia type cleaners.
2. Carefully follow any instructions provided with the bottles of cleaning and sanitizing solution.
3. Always wear liquid-proof gloves and goggles to prevent the cleaning and sanitizing solutions from coming into contact with skin or eyes.
4. To prevent damage to the water pump seal, do not operate the icemaker with the control switch in the "WASH" position when the water tank is empty.

IMPORTANT

1. The cleaning valve is opened during cleaning and sanitizing to allow solution flow to the inside of the evaporator. It should be closed for all icemaking operation. The compressor will not operate unless this valve is completely closed.
2. To close the cleaning valve, the valve handle should be at a right angle to the valve body. To open the cleaning valve, the valve handle should be parallel to the valve body.

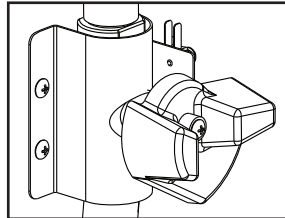

CLOSED

Normal Icemaking Operation

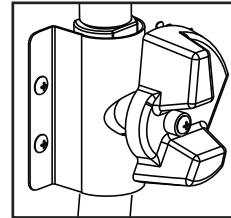

OPEN

Cleaning and Sanitizing Operation
(allows solution flow to the inside of
the evaporator)

1. Cleaning Procedure

- 1) Dilute 35 fl. oz. (400 ml) of Hoshizaki "Scale Away" with 2.5 gal. (9.5 l) of warm water.
- 2) Remove all ice from the evaporator and the dispenser unit/storage bin.
Note: To remove cubes on the evaporator, turn off the power supply and turn it back on after 3 minutes. The harvest cycle starts and the cubes will be removed from the evaporator.
- 3) Turn off the power supply.
- 4) Remove the front panel. Remove the insulation panel. Remove cube guide B, then remove cube guide A. See Fig. 6. Remove the overflow cap, overflow pipe, and water shield.
- 5) Remove the drain plug. Allow the water tank to drain, then replace the drain plug in its correct position. Be careful not to cross thread it.
- 6) Replace the water shield, overflow pipe, overflow cap, cube guide A and cube guide B in their correct positions. Be careful not to cross thread the overflow pipe.
- 7) In bad or severe water conditions, clean the float switch as described below. Otherwise, continue to step 8.
 - a. Disconnect the vent tube and the flush tube from the top of the float switch housing, then remove the float switch assembly. Remove the rubber boot from the bottom of the assembly.
 - b. Remove the retainer rod from the bottom of the float switch housing, then remove the float. Be careful not to bend the retainer rod excessively when removing it.
 - c. Wipe down the float switch housing, shaft, float, and retainer rod with cleaning solution. Clean the inside of the rubber boot and hose with cleaning solution. Rinse the parts thoroughly with clean water.
 - d. Reassemble the float switch assembly and replace it and the rubber boot in their correct positions. Reconnect the vent tube and the flush tube.

- 8) Pour the cleaning solution into the water tank.
- 9) Fully open the cleaning valve on the left side wall of the machine compartment.
- 10) Move the control switch to the "WASH" position. Replace the insulation panel and the front panel in their correct positions.
- 11) Turn on the power supply to start the washing process.
- 12) Turn off the power supply after 30 minutes.
- 13) Remove the front panel.
- 14) Remove the insulation panel. Remove cube guide B, then remove cube guide A. Remove the overflow cap, overflow pipe, and water shield.
- 15) Remove the drain plug. Allow the water tank to drain, then replace the drain plug in its correct position.
- 16) Replace the water shield, overflow pipe, overflow cap, cube guide A, cube guide B, and insulation panel in their correct positions.
- 17) Move the control switch to the "ICE" position.
- 18) Close the cleaning valve.
Note: The icemaker will not operate unless the cleaning valve is completely closed.

- 19) Replace the front panel in its correct position.
- 20) Turn on the power supply to fill the water tank with water.
- 21) Turn off the power supply after 3 minutes.
- 22) Remove the front panel and fully open the cleaning valve.
- 23) Move the control switch to the "WASH" position.
- 24) Replace the front panel in its correct position.
- 25) Turn on the power supply to rinse off the cleaning solution.

- 26) Turn off the power supply after 5 minutes.
- 27) Remove the front panel.
- 28) Remove the insulation panel. Remove cube guide B, then remove cube guide A. Remove the overflow cap, overflow pipe, and water shield.
- 29) Remove the drain plug. Allow the water tank to drain, then replace the drain plug in its correct position.
- 30) Replace the water shield, overflow pipe, overflow cap, cube guide A, cube guide B, and insulation panel in their correct positions.

- 31) Repeat steps 17 through 30 three more times to rinse thoroughly.

Note: If you do not sanitize the icemaker, go to step 12 in "2. Sanitizing Procedure."

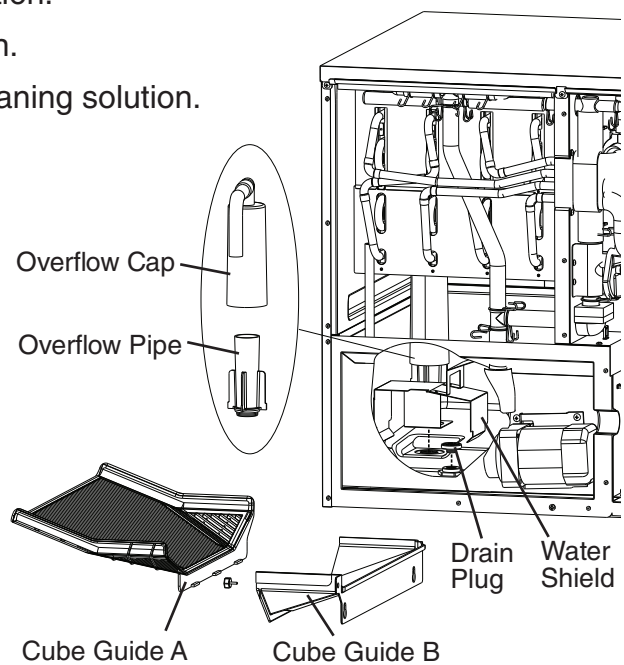

Fig. 6

2. Sanitizing Procedure - Following Cleaning Procedure

- 1) Dilute a 5.25% sodium hypochlorite solution (chlorine bleach) with warm water (add 1.25 fl. oz. (37 ml) to 2.5 gal. (9.5 l) of water).
- 2) Remove the insulation panel.
- 3) Pour the sanitizing solution into the water tank.
- 4) Replace the insulation panel and the front panel in their correct positions.
Note: Make sure the control switch is in the "WASH" position and the cleaning valve is open.
- 5) Turn on the power supply to start the sanitizing process.
- 6) Turn off the power supply after 15 minutes.
- 7) Remove the front panel.
- 8) Remove the insulation panel. Remove cube guide B, then remove cube guide A. Remove the overflow cap, overflow pipe, and water shield.
- 9) Remove the drain plug. Allow the water tank to drain, then replace the drain plug in its correct position.
- 10) Replace the water shield, overflow pipe, overflow cap, cube guide A, cube guide B, and insulation panel in their correct positions.
- 11) Repeat steps 17 through 30 in "1. Cleaning Procedure" two times to rinse thoroughly.
- 12) Close the cleaning valve.
- 13) Move the control switch to the "ICE" position.
- 14) Replace the front panel in its correct position.
- 15) Clean the dispenser unit/storage bin liner using a neutral cleaner. Rinse thoroughly after cleaning.
- 16) Turn on the power supply to start the automatic icemaking process.

B. Maintenance

This icemaker must be maintained individually, referring to the instruction manual and labels provided with the icemaker.

⚠ WARNING

1. Only qualified service technicians should attempt to service this icemaker.
2. Disconnect power before servicing.

1. Stainless Steel Exterior

To prevent corrosion, wipe the exterior occasionally with a clean, soft cloth. Use a damp cloth containing a neutral cleaner to wipe off oil or dirt buildup.

2. Dispenser Unit/Storage Bin and Scoop

- Wash your hands before removing ice. Use the plastic scoop provided (bin accessory).
- The dispenser unit/storage bin is for ice use only. Do not store anything else in the dispenser unit/storage bin.
- Clean the scoop and the dispensing unit/storage bin liner using a neutral cleaner. Rinse thoroughly after cleaning.

4. Condenser

Check the condenser once a year, and clean the coil if required by using a brush or vacuum cleaner. More frequent cleaning may be required depending on location.

C. Preparing the Icemaker for Long Storage

⚠ CAUTION

1. When storing the icemaker for an extended time or in sub-freezing temperatures, follow the instructions below to prevent damage.
2. To prevent damage to the water pump seal, do not operate the icemaker with the control switch in the "WASH" position when the water tank is empty.

When the icemaker is not used for two or three days, it is sufficient to only move the control switch to the "OFF" position. Unless the icemaker will be at sub-freezing temperatures.

1. Remove the water from the icemaker water supply line:

- 1) Turn off the power supply and remove the front panel.
- 2) Close the icemaker water supply line shut-off valve and open the icemaker water supply line drain valve.
- 3) Allow the line to drain by gravity.
- 4) Attach a compressed air or carbon dioxide supply to the icemaker water supply line drain valve.
- 5) Make sure at least 3 minutes have elapsed since you turned off the power supply. Make sure the control switch is in the "ICE" position. Replace the front panel in its correct position and turn on the power supply.
- 6) Blow the icemaker water supply line out using the compressed air or carbon dioxide supply.
- 7) Close the icemaker water supply line drain valve.

2. Drain the water tank:

- 1) Turn off the power supply.
- 2) Remove the front panel, then move the control switch to the "OFF" position.
- 3) Remove the insulation panel. Remove cube guide B, then remove cube guide A. See Fig. 6. Remove the overflow cap, overflow pipe, and water shield.
- 4) Remove the drain plug. Allow the water tank to drain, then replace the drain plug in its correct position. Be careful not to cross thread it.
- 5) Replace the water shield, overflow pipe, overflow cap, cube guide A, cube guide B, and insulation panel in their correct positions. Be careful not to cross thread the overflow pipe.
- 6) Remove all ice from the dispenser unit/storage bin. Clean the dispenser unit/storage bin using a neutral cleaner. Rinse thoroughly after cleaning.
- 7) Replace the front panel in its correct position.