

# Hoshizaki America, Inc.

## Professional Series Refrigerated Kitchen Equipment

Models  
RFH1-SSB-HS  
RFH1-SSB-HSE



“A Superior Degree  
of Reliability”

[www.hoshizaki.com](http://www.hoshizaki.com)

## PARTS LIST



Number: 71319  
Issued: 4-19-2011  
Revised: 9-3-2015

## CONTENTS

Auxiliary Codes.....	3
Note About Ordering Parts .....	3
A. Main Assembly .....	4
B. Refrigeration Circuit.....	7
C. Control Box Assembly .....	11
D. Upper Panel & Control Panel Assemblies .....	13
RFH1-SSB-HS.....	13
RFH1-SSB-HSE .....	15
E. Solid Right Hinged Half-Door .....	17
F. Accessories & Labels.....	19

## **Auxiliary Codes**

### **RFH1-SSB-HS**

V-5 October 2010  
A-5 January 2011  
B-5 January 2012  
B-6 September 2012  
C-5 March 2013  
D-5 January 2014  
D-6 September 2014  
E-5 January 2015  
E-6 May 2016

### **RFH1-SSB-HSE**

V-5 December 2010  
A-5 January 2011  
B-5 February 2012  
B-6 September 2012  
C-5 January 2013  
D-5 February 2014  
D-6 October 2014  
E-5 April 2015  
E-6 May 2015

## **Auxiliary Code Breakdown**

The auxiliary code is the first two characters in the serial number. The first character indicates the year. Years progress or regress in alphabetical order. The series runs from "A" through "V" and the letters "I" and "O" are skipped. The second character indicates significant part changes within a year. Base is "5" and this number advances for each change. In cases where there is a letter in parentheses, this designates the month. This is the last character in the serial number. The series runs from "(A)" through "(M)" and the letter "(I)" is skipped. This designation is only included when identifying a parts change within an auxiliary code.

## **Note About Ordering Parts**

Most assemblies cannot be ordered as complete units; parts in the assemblies generally must be ordered separately.

**A. Main Assembly**  
**RFH1-SSB-HS(-HSE)**  
**1/2**  
 V-5 to E-6

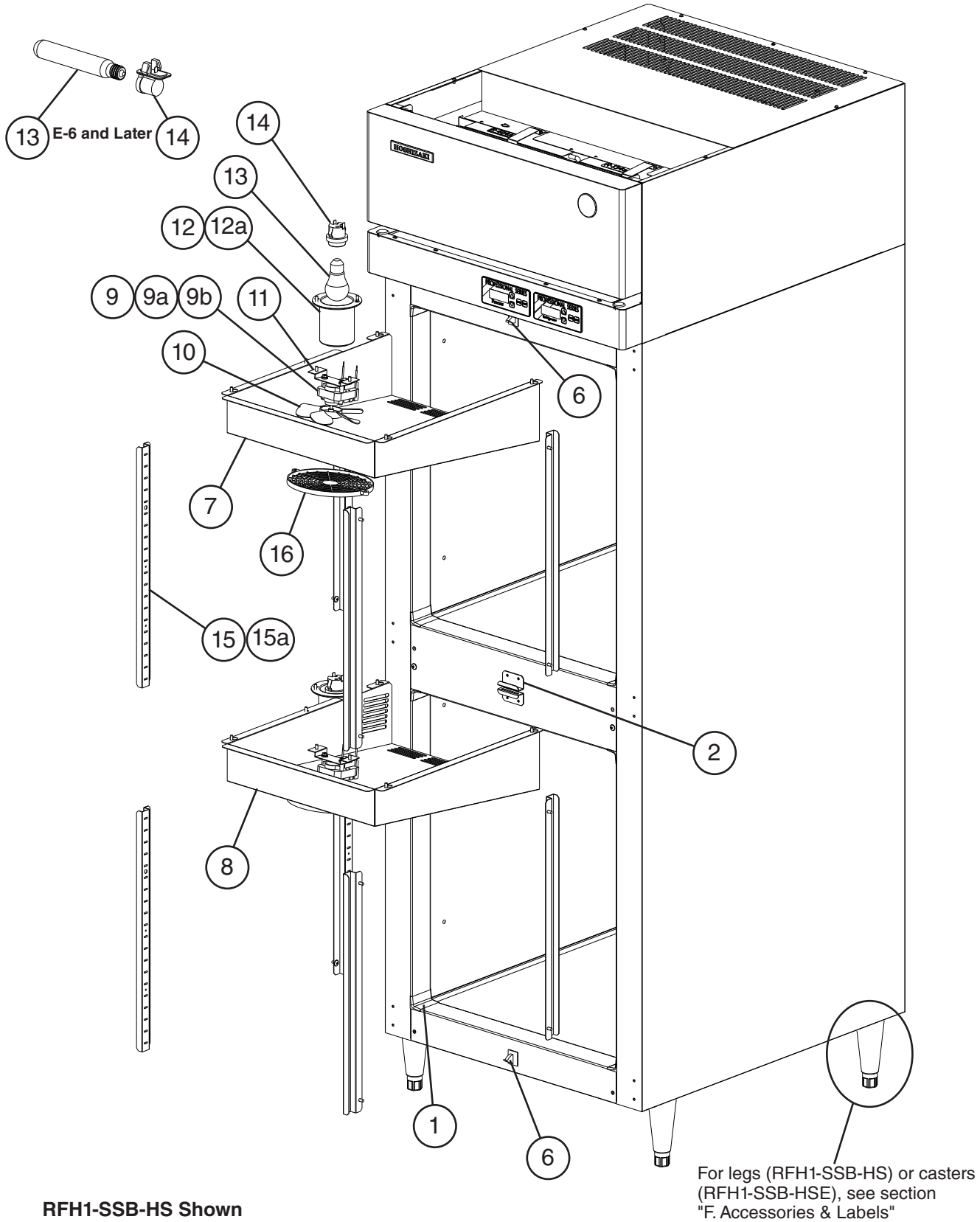

**RFH1-SSB-HS Shown**

**A. Main Assembly**  
**RFH1-SSB-HS(-HSE)**  
**2/2**  
V-5 to E-6

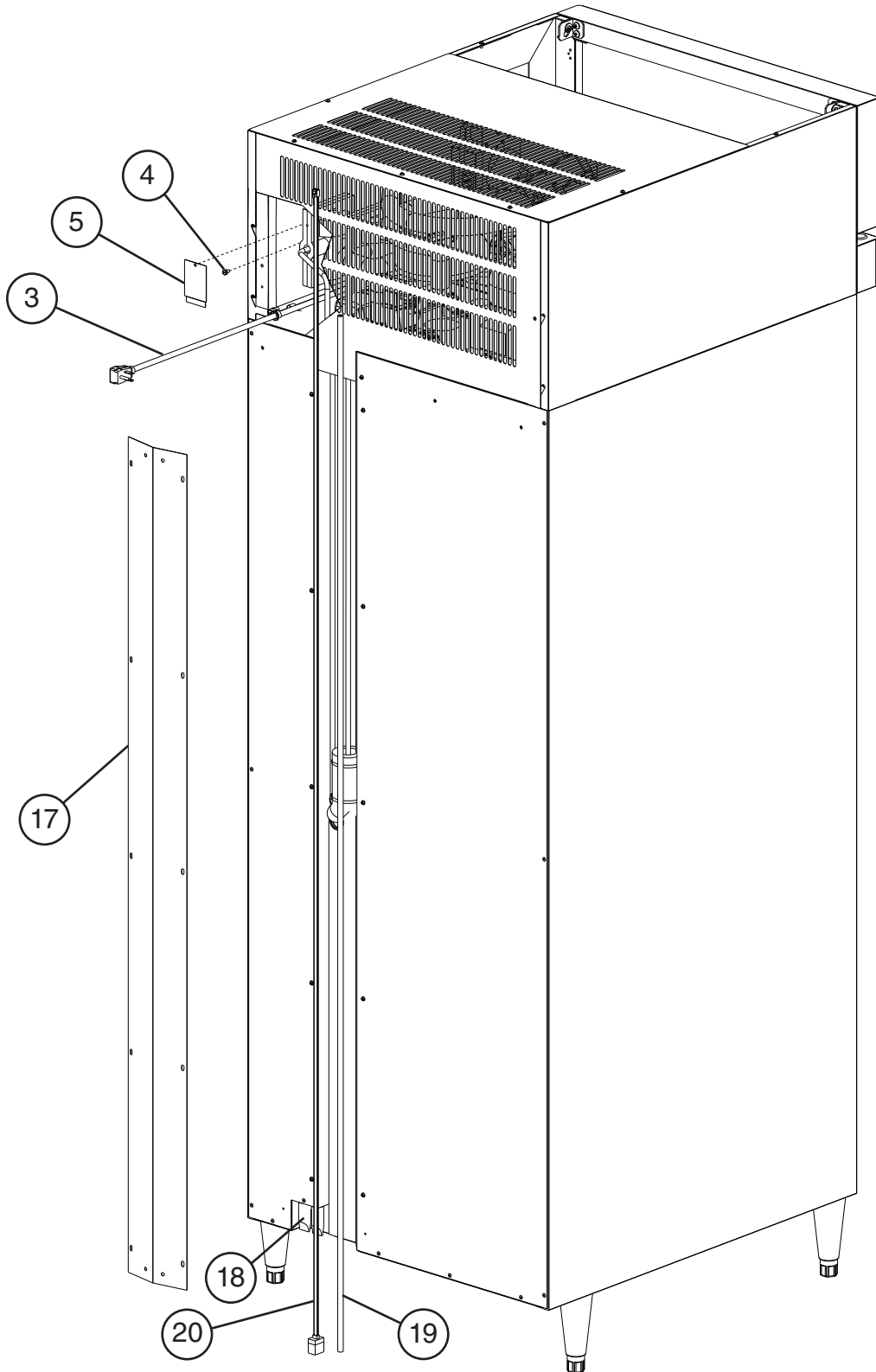

**Title: A. Main Assembly    Model: RFH1-SSB-HS(HSE)**

Index No.	Description	Material or Model Number	Part Number	Required Number									
				V-5 to E-5	E-6								
1	Corner Cover		3A1751-01	8	8								
2	Strike Plate		4A4587-01	2	2								
3	Power Cord		4A0520-01	1	1								
4	Ground Screw		433304-02	1	1								
5	Junction Box Cover		4A1992-01	1	1								
6	Door Switch		3A1826-01	2	2								
7	Upper Evaporator Cover		2A6275-01	1	1								
8	Lower Evaporator Cover		2A6275-02	1	1								
9	Fan Motor		4A4942-01	2	2								
9a	Split Lock Washer		7L2210832	4	4								
9b	Hex Nut	8-32	7N0210832	4	4								
10	Fan Blade		4A4943-01	2	2								
11	Fan Motor Bracket		4A5245-01	2	2								
12	Light Shield		4A0465-01	2	-								
12a	Cheese Head Screw	5x12	7C52-0512	4	-								
13	Light Bulb		4A2420-01	2	-								
			4A4444-01		2								
14	Lamp Holder		4A2862-01	2	-								
	Light Socket		4A4443-01		2								
15	Pilaster		3A1334-01	8	8								
15a	Truss Head Screw	5x10	7C32-0510	16	16								
16	Fan Guard		4A4860-01	2	2								
17	Rear Cover		3A6274-01	1	1								
18	Drain Boot		4A4938-01	2	2								
19	PVC Tubing	L=1900 mm	771611438	1	1								
20	Float Switch Extension Cable		4A5310-01	1	1								

# B. Refrigeration Circuit RFH1-SSB-HS(-HSE)

1/2

V-5 to E-6

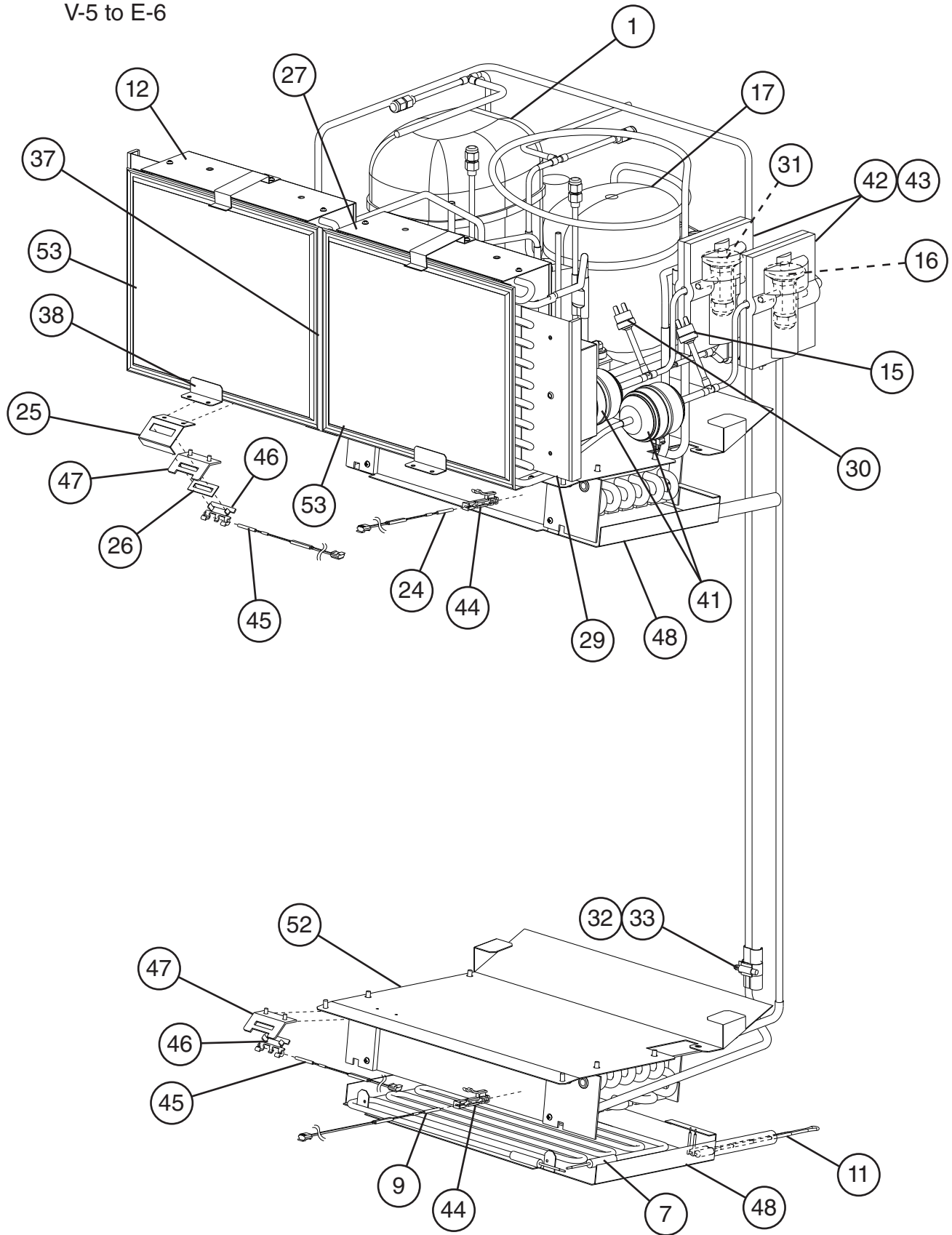

**B. Refrigeration Circuit**  
**RFH1-SSB-HS(-HSE)**  
**2/2**  
V-5 to E-6

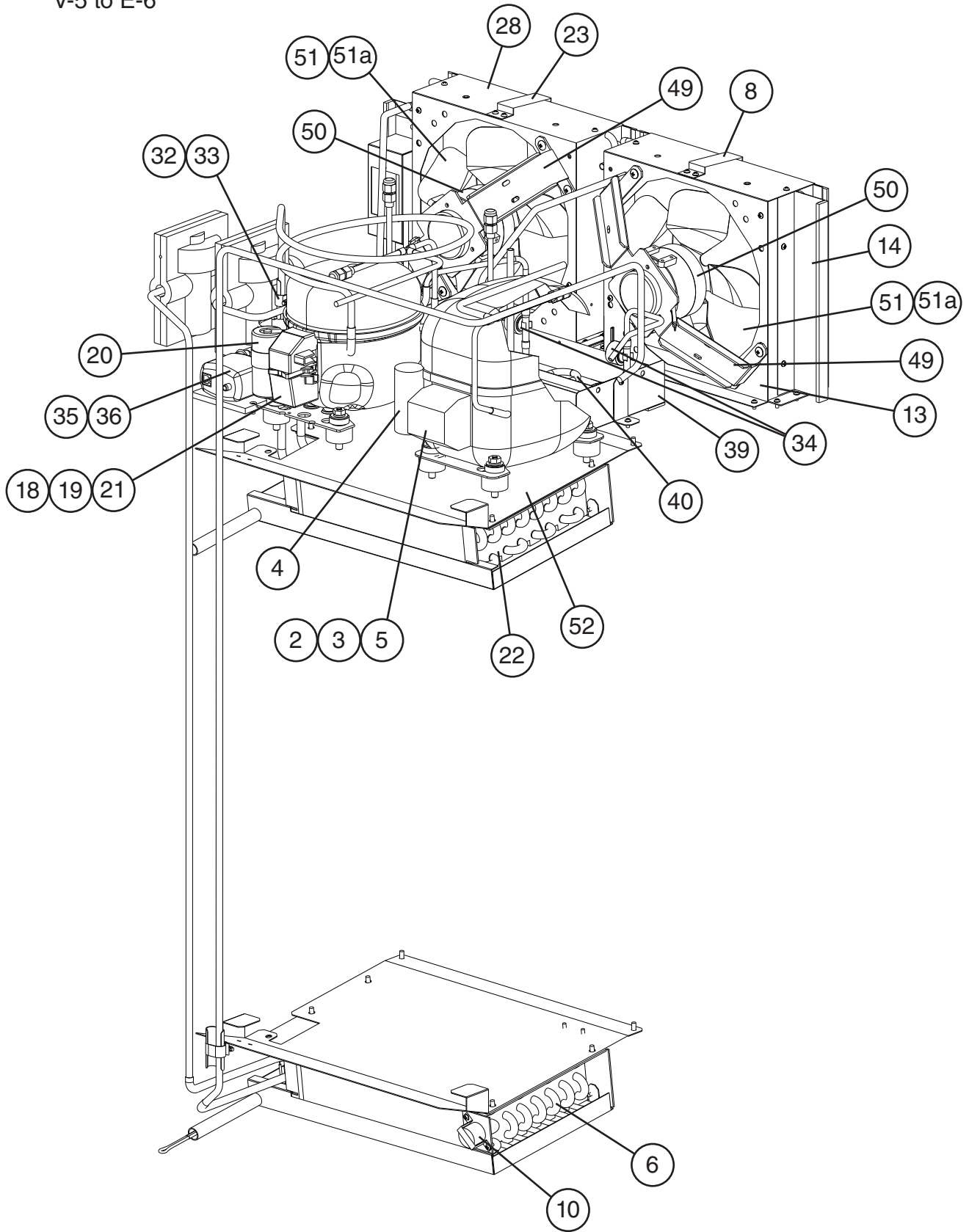



Title: B. Refrigeration Circuit Model: RFH1-SSB-HS(-HSE)												
Index No.	Description	Material or Model Number	Part Number	Required Number								
				V-5 (K)	V-5 (M) to A-5 (E)	A-5 (F) to B-5	B-6 to E-6					
<b>Freezer</b>												
1	Compressor		4A4185-01	1	1	1	1					
2	Terminal Cover		4A2141-01	1	1	1	1					
3	Cord Relief		4A2152-01	2	2	2	2					
4	Start Capacitor		4A2134-04	1	1	1	1					
5	Start Relay		4A2135-04	1	1	1	1					
6	Evaporator		2A2289-01	1	1	1	1					
7	Defrost Heater		3A1849-01	1	1	1	1					
8	Air Filter Retainer		4A0790-01	1	-							
			4A0790-02		1	1	1					
9	Defrost Thermistor		4A1428-02	1	1	1	1					
10	Defrost Thermostat		4A0954-02	1	1	1	1					
11	Drain Heater		4A2975-04	1	1	1	1					
12	Condenser		2A0782-01	1	-							
			3A6634G01		1	1	1					
13	Condenser Shroud		2A6235-01	1	-							
			3A6632G01		1	1	1					
14	Condenser Block		3A6304-02		1	1	1					
15	High-Pressure Switch		4A2516-02	1	1	1	1					
16	Thermostatic Expansion Valve		4A5165-01	1	1	1	1					
<b>Refrigerator</b>												
17	Compressor		4A5172-01	1	1	1	1					
18	Terminal Cover		4A2141-01	1	1	1	1					
19	Cord Relief		4A2152-01	2	2	2	2					
20	Start Capacitor		4A2134-04	1	1	1	1					
21	Start Relay		4A2135-05	1	1	1	1					
22	Evaporator		2A2290-01	1	1	1	1					
23	Air Filter Retainer		4A0790-01	2	-							
			4A0790-02		1	1	1					
24	Defrost Thermistor		4A1428-01	1	1	1	1					
25	Thermistor Shield		4A2057-01	1	1	1	1					
26	Thermistor Bracket		4A3004-01	1	1	1	1					
27	Condenser		2A0623-01	1	-							
			3A6635G01		1	1	1					
28	Condenser Shroud		3A6266G01	1	-							
			3A6633G01		1	1	1					
29	Junction Box		3A6306G01		1	1	1					
30	High-Pressure Switch		4A2516-01	1	1	1	1					
31	Thermostatic Expansion Valve		4A5164-01	1	1	1	1					

**Title: B. Refrigeration Circuit    Model: RFH1-SSB-HS(-HSE)**

Index No.	Description	Material or Model Number	Part Number	Required Number							
				V-5 (K)	V-5 (M) to A-5 (E)	A-5 (F) to B-5	B-6 to E-6				
<b>Common</b>											
32	Thermostatic Expansion Valve Bulb Holder		3A0107-01	2	2	2	2				
33	Clamp		443461-01	2	2	2	2				
34	Clogged Filter Thermostat		4A0484-01	2	2	2	2				
35	Condensate Water Pump (includes float switch)		HS-5028	1	1	1	-				
			4A5546-01				1				
36	PVC Tubing	L=250 mm	7716I1438	1	1	1	2				
37	Air Block		4A5252-01		1	1	2				
38	Filter Bracket		4A5265-01		2	2	2				
39	Condensate Pan		2A5218-01	1	1	1	1				
40	Condensate Coil		3A6129-01	2	2	2	2				
41	Drier		4A0924-01	2	2	2	2				
42	Thermostatic Expansion Valve Cover A		3A0372-01	2	2	-					
	Thermostatic Expansion Valve Cover		4A4646-01			2	2				
43	Thermostatic Expansion Valve Cover B		3A0372-02	2	2	-					
44	Thermistor Clip		320418-01	2	2	2	2				
45	Cabinet Thermistor		4A1429-02	2	2	2	2				
46	Thermistor Bracket		433920-01	2	2	2	2				
47	Thermistor Bracket		433964-01	2	2	2	2				
48	Drain Pan		4A5225G01	2	2	2	2				
49	Condenser Fan Bracket		3A1564-01	2	2	2	2				
50	Condenser Fan Motor		4A4620-01	2	2	2	2				
51	Condenser Fan Blade		3A0436-01	2	2	2	2				
51a	Hex Nut		4A1345-01	2	2	2	2				
52	Evaporator Mount		3A1857-01	2	2	2	2				
53	Air Filter		3A0277-01	2	2	2	2				

**C. Control Box Assembly**  
**RFH1-SSB-HS(-HSE)**  
 V-5 to D-5

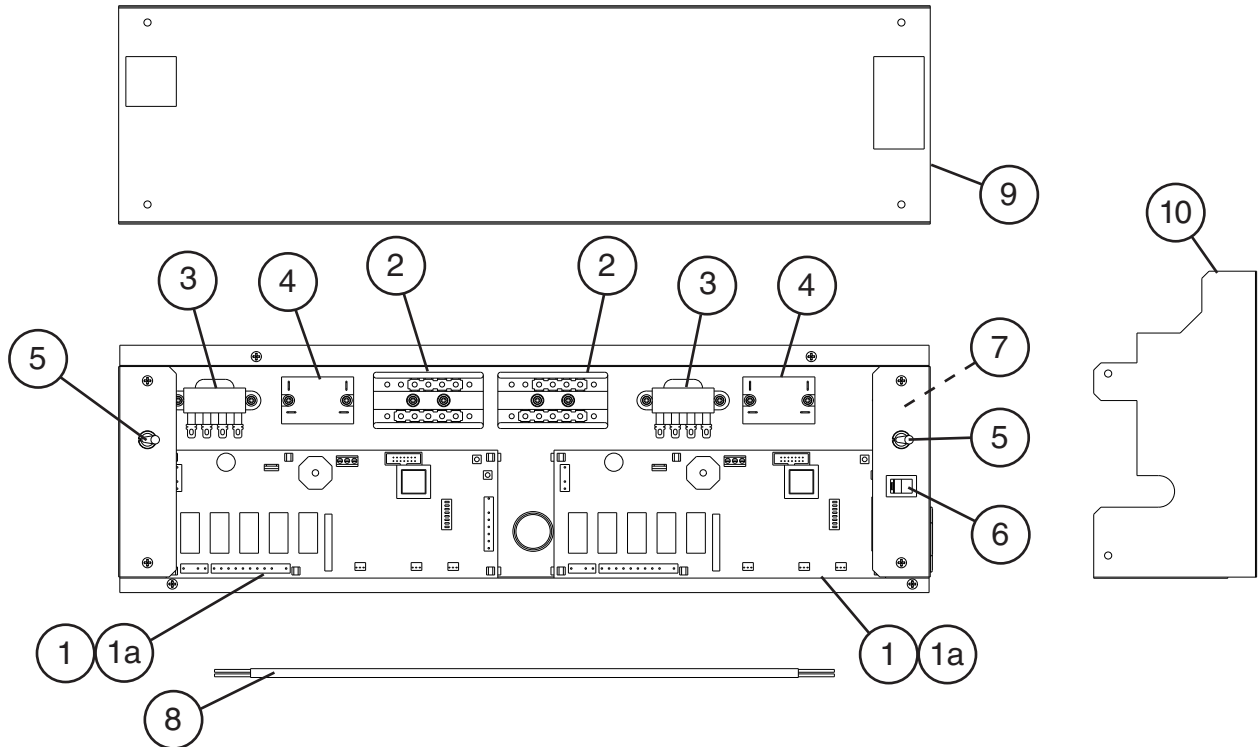

**C. Control Box Assembly**  
**RFH1-SSB-HS(-HSE)**  
 D-6 to E-6

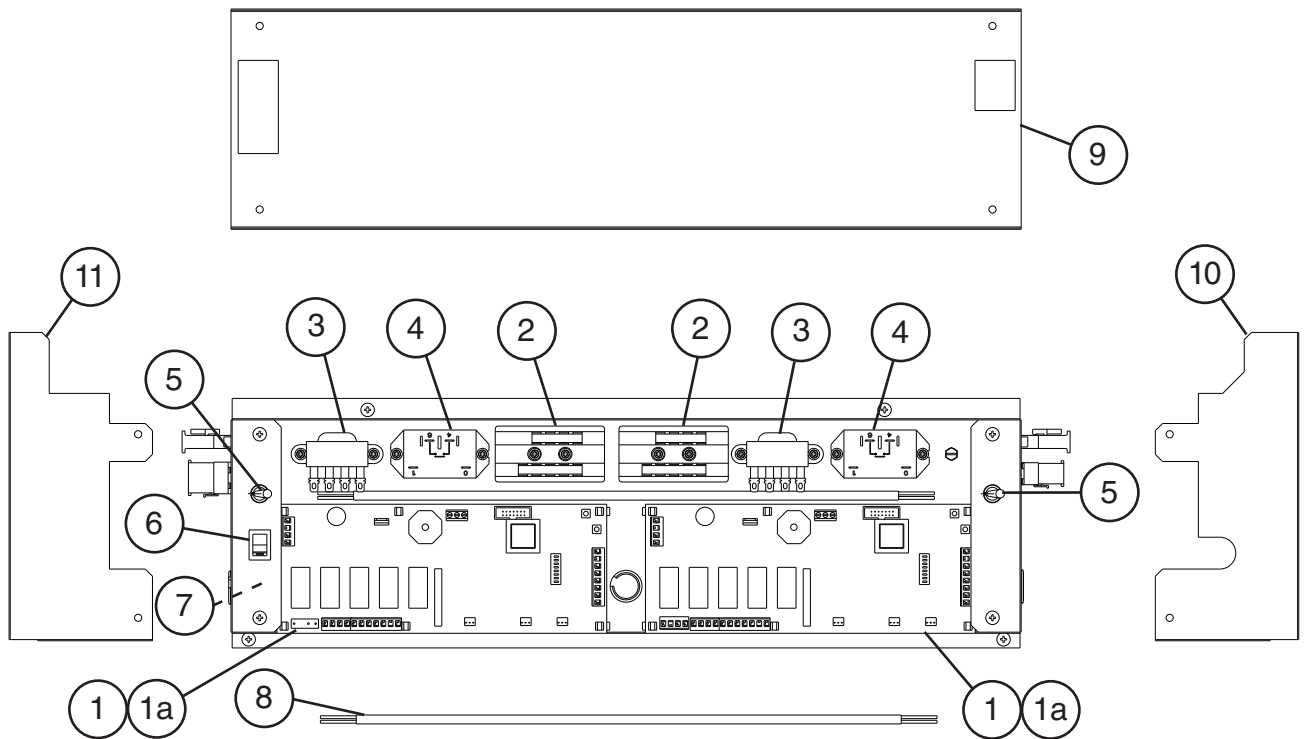

Title: C. Control Box Assembly Model: RFH1-SSB-HS(-HSE)											
Index No.	Description	Material or Model Number	Part Number	Required Number							
				V-5 to D-5	D-6 to E-6						
1	Control Board		2A2862-24	2	2						
1a	Control Board Support		4A0336-03	12	12						
2	Terminal Block		4A2619-01	2	2						
3	Control Transformer		3A1759-01	2	2						
4	Compressor Relay		4A1307-01	2	-						
			4A3140-01		2						
5	Power Switch		4A0424-01	2	2						
6	Perimeter Heater Switch		4A0418-01	1	1						
7	Ground Screw		433304-02	1	1						
8	Data Cable	L=380 mm	4A1801L01	1	1						
9	Control Box Cover		2A6390-01	1	-						
			2A7455-01		1						
10	Right Wire Cover		4A5289-01	1	-						
			4A5760-01		1						
11	Left Wire Cover		4A5761-01		1						

# D. Upper Panel & Control Panel Assemblies

## RFH1-SSB-HS

V-5 to E-6

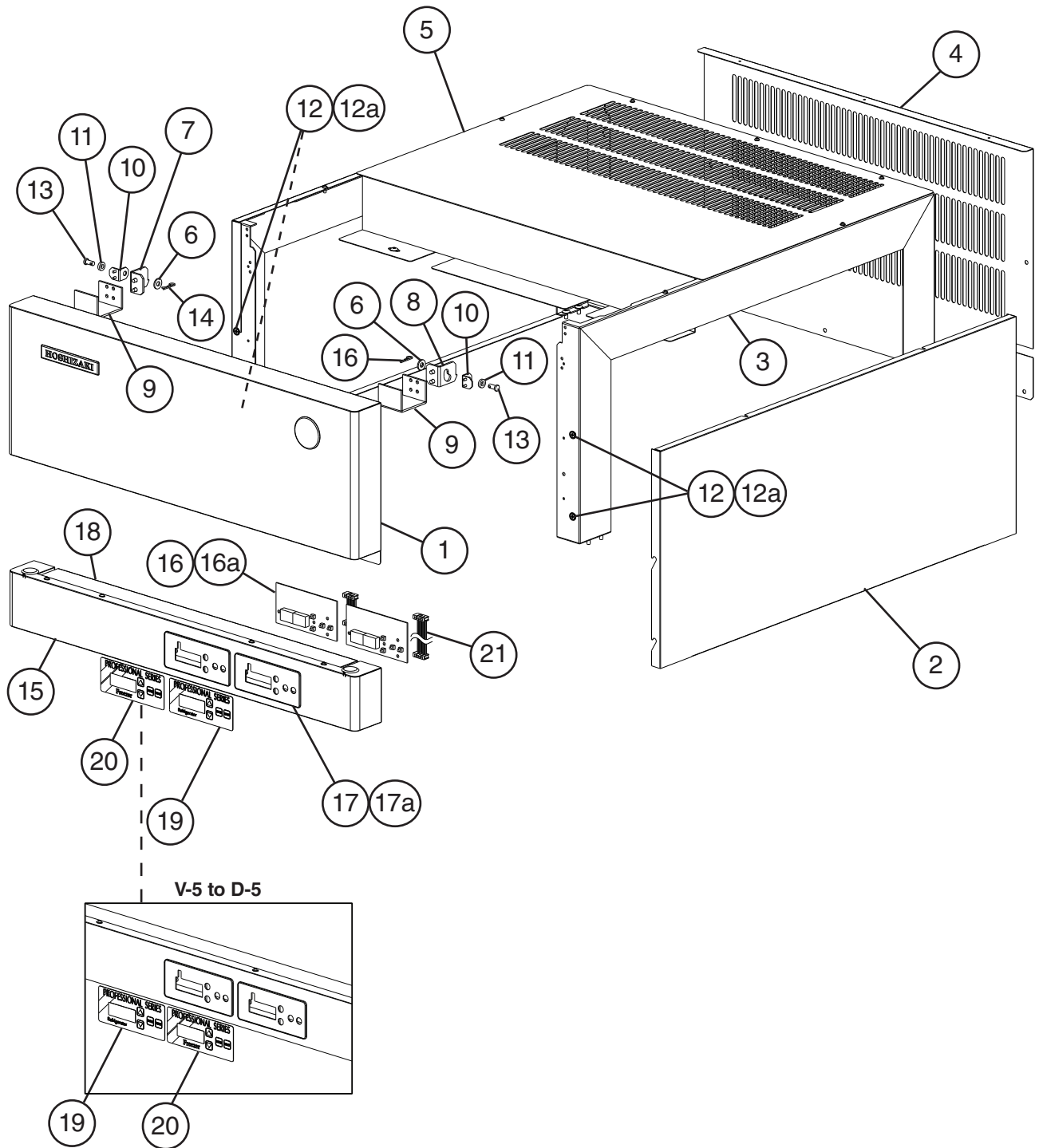

Title: D: Upper Panel & Control Panel Assemblies Model: RFH1-SSB-HS												
Index No.	Description	Material or Model Number	Part Number	V-5 to E-6	Required Number							
<b>Upper Panel Assembly</b>												
1	Front Panel		1A0624-04	1								
2	Side Top Panel		2A1800-01	2								
3	Side Top Frame		2A1803-01	2								
4	Rear Cover		2A2104-01	1								
5	Top Cover		2A6330-01	1								
6	Flat Washer		4A0655-03	2								
7	Left Front Panel Hinge		4A2153-01	1								
8	Right Front Panel Hinge		4A2154-01	1								
9	Hinge Channel		4A2170-01	2								
10	Hinge Bracket		4A2306-01	2								
11	Hinge Spacer		4A2473-01	2								
12	Taper Collar		4H0171-01	4								
12a	Countersunk Screw	5x20, SS	7C42-0520	4								
13	Clevis Pin		8907-0102	2								
14	Cotter Pin		8907-0103	2								
<b>Front (Control) Panel Assembly</b>												
15	Control Panel		1A0760-02	1								
16	Display Board		2A0883-01	2								
16a	Nylon Screw		4A1397-01	8								
17	Display Board Mount		3A0823-01	2								
17a	Palnut		4A1398-01	12								
18	Wire Cover		3A2577-01	1								
19	Refrigerator Display Label		3A5788-01	1								
20	Freezer Display Label		3A5788-02	1								
21	Ribbon Cable		4A1106-01	2								

# D. Upper Panel & Control Panel Assemblies

## RFH1-SSB-HSE

V-5 to E-6

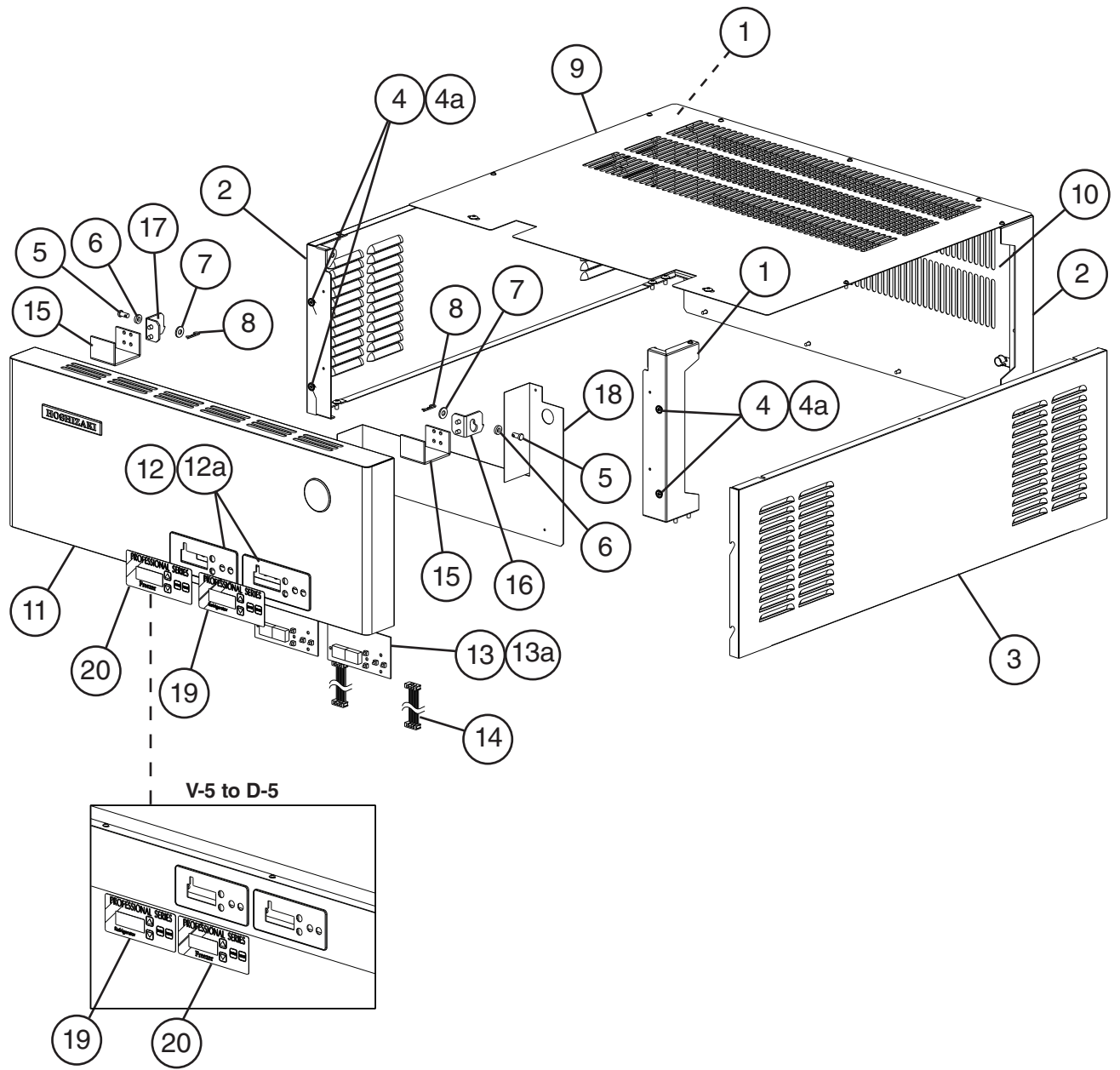

Title: D: Upper Panel & Control Panel Assemblies Model: RFH1-SSB-HSE												
Index No.	Description	Material or Model Number	Part Number	V-5 to E-6	Required Number							
<b>Upper Panel Assembly</b>												
1	Side Top Frame		2A6309-01	2								
2	Side Top Frame		2A6309-02	2								
3	Side Top Panel		2A6312-01	2								
4	Taper Collar		4H0171-01	4								
4a	Countersunk Screw	5x20, SS	7C42-0520	4								
5	Clevis Pin		8907-0102	2								
6	Hinge Spacer		4A2473-01	2								
7	Flat Washer		4A0655-03	2								
8	Cotter Pin		8907-0103	2								
9	Top Cover		2A6328-01	1								
10	Rear Cover		2A6329-01	1								
<b>Front (Control) Panel Assembly</b>												
11	Front Hinged Panel		2A6391-01	1								
12	Display Board Mount		3A0823-01	2								
12a	Palnut		4A1398-01	12								
13	Display Board		2A0883-01	2								
13a	Nylon Screw		4A1397-01	8								
14	Ribbon Cable		4A1106-02	2								
15	Hinge Channel		4A2170-01	2								
16	Right Hinge Front Panel		4A2154-01	1								
17	Left Hinge Front Panel		4A2153-01	1								
18	Board Cover		2A6392-01	1								
19	Refrigerator Display Label		3A5788-01	1								
20	Freezer Display Label		3A5788-02	1								



# E. Solid Right Hinged Half-Door RFH1-SSB-HS(-HSE)

V-5 to E-6

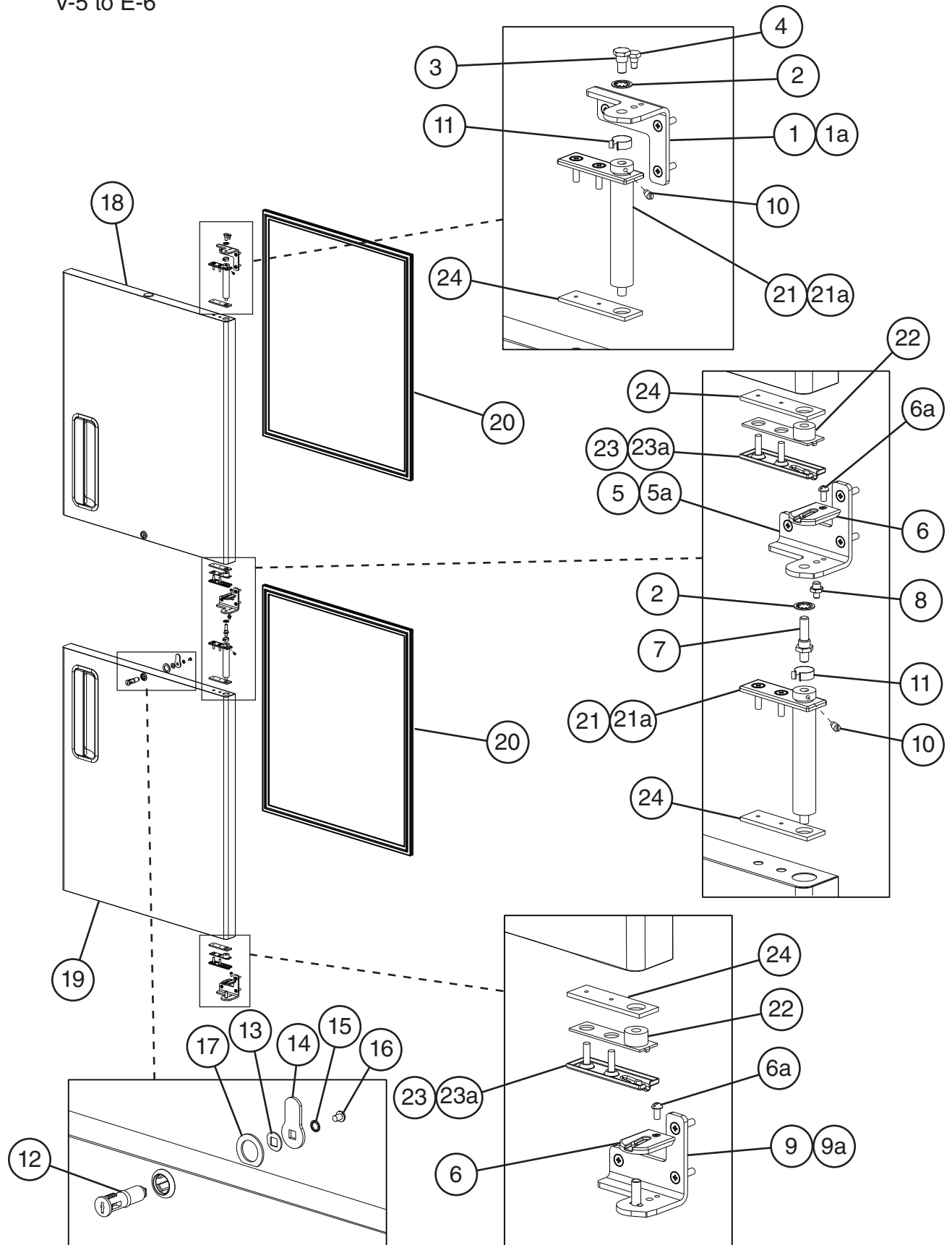

Title: E. Solid Right Hinged Half-Door Model: RFH1-SSB-HS(-HSE)											
Index No.	Description	Material or Model Number	Part Number	V-5 to E-6	Required Number						
1	Door Hinge Bracket (UR)		3A1580-01	1							
1a	Countersunk Screw	5x20, SS	7C42-0520	3							
2	Hinge Lock Washer		4A0553-01	2							
3	Hinge Pivot Pin (top)		4A2179-01	1							
4	Hinge Stop Pin (top)		4A2180-01	1							
5	Door Hinge Bracket (UL)		3A1581-01	1							
5a	Countersunk Screw	5x20, SS	7C42-0520	3							
6	Right Female Hinge Bottom Plate		4A0441-01	2							
6a	Stop Plate Screw		4A0483-01	2							
7	Hinge Pivot Pin (center)		4A1735-01	1							
8	Hinge Stop Pin (center)		4A1734-01	1							
9	Door Hinge Bracket (LR)		3A1626-01	1							
9a	Countersunk Screw	5x20, SS	7C42-0520	3							
10	Hinge Tension Screw		4A0446-01	2							
11	Hinge Bushing Cover		4A0445-01	2							
12	Door Lock Tumbler (includes key 4A0460-01)		4A0462-01	2							
13	Door Lock Stop Washer		4A0458-01	2							
14	Door Lock Cam		4A0228-01	2							
15	Door Lock Lock Washer		4A0459-01	2							
16	Door Lock Screw		4A0461-01	2							
17	Door Lock Washer		4A0670-01	2							
18	Door (UR, LL) (includes half the quantity of items 20 through 24)		2A3934G01	1							
19	Door (LR, UL) (includes half the quantity of items 20 through 24)		2A3935G01	1							
20	Door Gasket		3A0273-02	2							
21	Right Hinge Spring Cartridge		4A0438-01	2							
21a	Countersunk Screw	5x20, SS	7C42-0520	4							
22	Right Hinge Bottom Bushing		4A0439-01	2							
23	Right Male Hinge Bottom Plate		4A0440-01	2							
23a	Countersunk Screw	5x20, SS	7C42-0520	4							
24	Foam Pad		4A2257-01	4							

**F. Accessories & Labels**  
**RFH1-SSB-HS(-HSE)**  
 V-5 to E-6

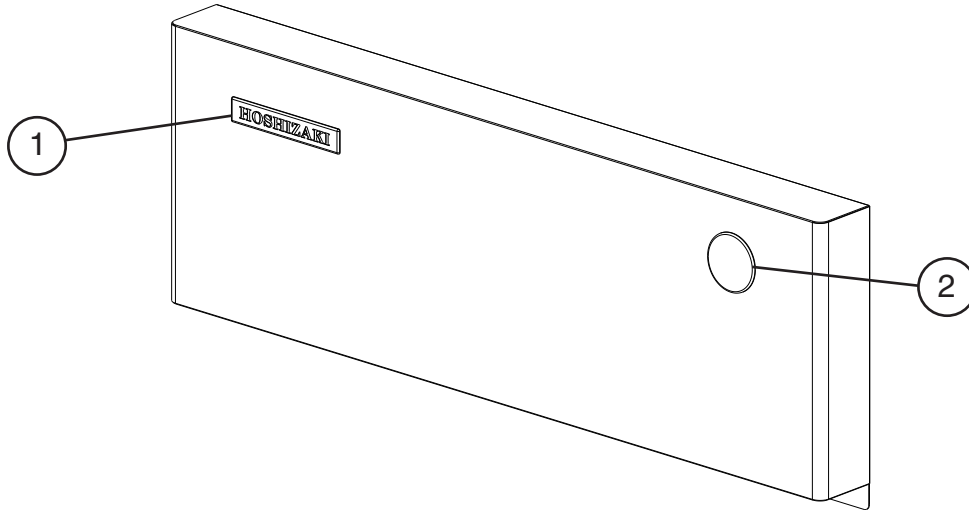

Title: F. Accessories & Labels Model: RFH1-SSB-HS(-HSE)										
Index No.	Description	Material or Model Number	Part Number	Required Number						
				V-5 to E-6						
1	Hoshizaki Emblem		<a href="#">4A0560-01</a>	1						
2	Penguin Label		<a href="#">456246-02</a>	1						
3	Reservior		<a href="#">3A6276-01</a>	1						
4	Shelf 3 Pack-Coated	HS-3508	3A1416A03	1						
5	Leg (4 Pack)	<b>RFH1-SSB-HS</b> HS-3512	<a href="#">4A0930-01</a>	1						
6	3-Inch Locking Caster	<b>RFH1-SSB-HSE</b>	<a href="#">4A4302-01</a>	2						
6a	Hex Head Tapping Bolt	<b>RFH1-SSB-HSE</b> 1/4-20x3/4"	<a href="#">4A5213-01</a>	8						
7	3-Inch Non-Locking Caster	<b>RFH1-SSB-HSE</b>	<a href="#">4A4302-02</a>	2						
7a	Hex Head Tapping Bolt	<b>RFH1-SSB-HSE</b> 1/4-20x3/4"	<a href="#">4A5213-01</a>	8						