

NO.: 73079
ISSUED: DEC. 8, 1998
REVISED: DEC. 16, 2003



**HOSHIZAKI
STACKABLE CRESCENT CUBER**

**MODEL KM-1600SWF
KM-1600SRF
KM-1600SWF3
KM-1600SRF3**

SERVICE MANUAL

IMPORTANT

Only qualified service technicians should attempt to service or maintain this icemaker. No service or maintenance should be undertaken until the technician has thoroughly read this Service Manual.

HOSHIZAKI provides this manual primarily to assist qualified service technicians in the service and maintenance of the icemaker.

Should the reader have any questions or concerns which have not been satisfactorily addressed, please call or write to the HOSHIZAKI Technical Support Department for assistance.

HOSHIZAKI AMERICA, INC.
618 Highway 74 South
Peachtree City, GA 30269

Attn: HOSHIZAKI Technical Support Department

Phone: 1-800-233-1940 Technical Service
(770) 487-2331
Fax: (770) 487-3360

NOTE: To expedite assistance, all correspondence/communication **MUST** include the following information:

- Model Number
- Serial Number
- Complete and detailed explanation of the problem

Please review this manual. It should be read carefully before the icemaker is serviced or maintenance operations are performed. Only qualified service technicians should service and maintain the icemaker. This manual should be made available to the technician prior to service or maintenance.

CONTENTS

	PAGE
I. SPECIFICATIONS	5
1. KM-1600SWF (Water-cooled)	5
2. KM-1600SRF (Remote air-cooled)	6
3. KM-1600SWF3 (Water-cooled)	7
4. KM-1600SRF3 (Remote air-cooled)	8
5. CONDENSING UNIT, URC-20F	9
II. GENERAL INFORMATION	11
1. CONSTRUCTION	11
[a] KM-1600SWF, KM-1600SWF3	11
[b] KM-1600SRF, KM-1600SRF3	12
2. CONTROLLER BOARD	13
[a] SOLID-STATE CONTROL	13
[b] CONTROLLER BOARD	13
[c] SEQUENCE	18
[d] CONTROLS AND ADJUSTMENTS	21
[e] CHECKING CONTROLLER BOARD	24
III. TECHNICAL INFORMATION	26
1. WATER CIRCUIT AND REFRIGERANT CIRCUIT	26
[a] KM-1600SWF, KM-1600SWF3	26
[b] KM-1600SRF, KM-1600SRF3	27
2. WIRING DIAGRAMS	28
[a] KM-1600SWF, KM-1600SRF	28
[b] KM-1600SWF3, KM-1600SRF3	29
3. TIMING CHART	30
4. PERFORMANCE DATA	32
[a] KM-1600SWF	32
[b] KM-1600SRF	33
[c] KM-1600SWF3	34
[d] KM-1600SRF3	35
IV. SERVICE DIAGNOSIS	36
1. NO ICE PRODUCTION	36
2. EVAPORATOR IS FROZEN UP	39
3. LOW ICE PRODUCTION	39
4. ABNORMAL ICE	40
5. OTHERS	40

V. REMOVAL AND REPLACEMENT OF COMPONENTS	41
1. SERVICE FOR REFRIGERANT LINES	41
[a] REFRIGERANT RECOVERY	41
[b] EVACUATION AND RECHARGE	41
2. BRAZING	42
3. REMOVAL AND REPLACEMENT OF COMPRESSOR	43
4. REMOVAL AND REPLACEMENT OF DRIER	44
5. REMOVAL AND REPLACEMENT OF EXPANSION VALVE	45
6. REMOVAL AND REPLACEMENT OF HOT GAS VALVE, LINE VALVE AND GAS VALVE	46
7. REMOVAL AND REPLACEMENT OF EVAPORATOR	47
8. REMOVAL AND REPLACEMENT OF WATER-REGULATING VALVE - WATER COOLED MODEL ONLY	48
9. ADJUSTMENT OF WATER-REGULATING VALVE - WATER COOLED MODEL ONLY	49
10. REMOVAL AND REPLACEMENT OF CONDENSING PRESSURE REGULATOR (C.P.R.) - REMOTE AIR-COOLED MODEL ONLY	50
11. REMOVAL AND REPLACEMENT OF THERMISTOR	51
12. REMOVAL AND REPLACEMENT OF FAN MOTOR	52
13. REMOVAL AND REPLACEMENT OF WATER VALVE	52
14. REMOVAL AND REPLACEMENT OF PUMP MOTOR	53
15. REMOVAL AND REPLACEMENT OF SPRAY TUBES	54
VI. MAINTENANCE AND CLEANING INSTRUCTIONS	55
1. PREPARING THE ICEMAKER FOR LONG STORAGE	55
2. CLEANING PROCEDURE	57
[a] CLEANING PROCEDURE	58
[b] SANITIZING PROCEDURE	59
3. MAINTENANCE	60

I. SPECIFICATIONS

1. KM-1600SWF

AC SUPPLY VOLTAGE	208-230/60/1 (3 wire with neutral for 115V)			
AMPERAGE	15 A (5 Min. Freeze AT 104°F / WT 80°F)			
MINIMUM CIRCUIT AMPACITY	30 A			
MAXIMUM FUSE SIZE	30 A			
APPROXIMATE ICE PRODUCTION PER 24 HR. lbs./day (kg/day) Reference without *marks	Ambient Temp.(°F)	WATER TEMP. (°F)		
		50	70	90
	70	*1583 (718)	1555 (705)	1467 (666)
	80	1562 (708)	1518 (688)	1403 (636)
	90	1555 (705)	*1487 (674)	1382 (627)
	100	1521 (690)	1462 (663)	1285 (583)
SHAPE OF ICE	Crescent Cube			
ICE PRODUCTION PER CYCLE	30.9 lbs. (14 kg) 1440 pcs.			
APPROXIMATE STORAGE CAPACITY	N/A			
ELECTRIC & WATER CONSUMPTION	90/70°F	70/50°F		
ELECTRIC W (kWH/100 lbs.)	2602 (4.2)	2510 (3.8)		
WATER gal./24HR (gal./100 lbs.)	491 (33.0)	779 (49.2)		
WATER COOLED CONDENSER gal./24HR (gal./100 lbs.)	1993 (134)	1061 (67)		
EXTERIOR DIMENSIONS (WxDxH)	48" x 27-3/8" x 27-3/8" (1219 x 695 x 695 mm)			
EXTERIOR FINISH	Stainless Steel, Galvanized Steel (Rear)			
WEIGHT	Net 310 lbs. (141 kg), Shipping 360 lbs. (163 kg)			
CONNECTIONS - ELECTRIC	Permanent Connection			
- WATER SUPPLY	Inlet 1/2" FPT	Cond. Inlet	1/2" FPT	
- DRAIN	Outlet 3/4" FPT	Cond. Outlet	1/2" FPT	
	3/8" ID Pipe			
CUBE CONTROL SYSTEM	Float Switch			
HARVESTING CONTROL SYSTEM	Hot Gas and Water, Thermistor and Timer			
ICE MAKING WATER CONTROL	Timer Controlled. Overflow Pipe			
COOLING WATER CONTROL	Water Regulator			
BIN CONTROL SYSTEM	Thermostat			
COMPRESSOR	Hermetic, Model CS20K6E-PFV			
CONDENSER	Water-cooled, Tube in Tube type			
EVAPORATOR	Vertical type, Stainless Steel and Copper			
REFRIGERANT CONTROL	Thermostatic Expansion Valve			
REFRIGERANT CHARGE	R-404A, 3lbs. 1 oz (1400 g)			
DESIGN PRESSURE	High 427 PSIG, Low 230 PSIG			
P.C. BOARD CIRCUIT PROTECTION	High Voltage Cut-out (Internal)			
COMPRESSOR PROTECTION	Auto-reset Overload Protector (Internal)			
REFRIGERANT CIRCUIT PROTECTION	Auto-reset High Pressure Control Switch			
LOW WATER PROTECTION	Float Switch			
ACCESSORIES -SUPPLIED	N/A			
-REQUIRED	Ice Storage Bin			
OPERATING CONDITIONS	VOLTAGE RANGE	187 - 253 V		
	AMBIENT TEMP.	45 - 100° F		
	WATER SUPPLY TEMP.	45 - 90° F		
	WATER SUPPLY PRESSURE	10 - 113 PSIG		

* We reserve the right to make changes in specifications and design without prior notice.

2. KM-1600SRF

AC SUPPLY VOLTAGE	208-230/60/1 (3 wire with neutral for 115V)		
AMPERAGE	21A (5 Min. Freeze AT104°F / WT 80°F)		
MINIMUM CIRCUIT AMPACITY	30A		
MAXIMUM FUSE SIZE	30A		
APPROXIMATE ICE PRODUCTION PER 24 HR.	Ambient Temp.(°F)	WATER TEMP. (°F)	
lbs./day (kg/day)		50	70
Reference without *marks		90	
	70	*1430 (649)	1415 (642)
	80	1419 (644)	1396 (633)
	90	1415 (642)	*1380 (626)
	100	1383 (628)	1359 (616)
SHAPE OF ICE	Crescent Cube		
ICE PRODUCTION PER CYCLE	30.9 lbs. (14 kg) 1440 pcs.		
APPROXIMATE STORAGE CAPACITY	N/A		
ELECTRIC & WATER CONSUMPTION	90/70°F	70/50°F	
ELECTRIC W (kWH/100lbs.)	2965 (5.80)	2815 (4.67)	
POTABLE WATER	504 (36.5)	841 (58.8)	
gal./24HR (gal./100 lbs.)			
EXTERIOR DIMENSIONS (WxDxH)	48" x 27-3/8" x 27-3/8" (1219 x 695 x 695 mm)		
EXTERIOR FINISH	Stainless Steel, Galvanized Steel (Rear)		
WEIGHT	Net 285 lbs. (129 kg), Shipping 360 lbs. (163 kg)		
CONNECTIONS - ELECTRIC	Permanent Connection		
- WATER SUPPLY	Inlet 1/2" FPT		
- DRAIN	Outlet 3/4" FPT 3/8" ID Pipe		
CUBE CONTROL SYSTEM	Float Switch		
HARVESTING CONTROL SYSTEM	Hot Gas and Water. Thermistor and Timer		
ICE MAKING WATER CONTROL	Timer Controlled. Overflow Pipe		
COOLING WATER CONTROL	N/A		
BIN CONTROL SYSTEM	Thermostat		
COMPRESSOR	Hermetic, Model CS20K6E-PFV-279		
CONDENSER	Air-cooled remote, Condenser Unit URC-20F recommended		
EVAPORATOR	Vertical type. Stainless Steel and Copper		
REFRIGERANT CONTROL	Thermostatic Expansion Valve		
REFRIGERANT CHARGE	Condensing Pressure Regulator on URC-20F R-404A, 14 lbs. 12 oz. (6700 g) (Ice maker 7 lbs. 1 oz. Cond. unit 7 lbs. 11 oz.)		
DESIGN PRESSURE	High 467 PSIG, Low 230 PSIG		
P.C. BOARD CIRCUIT PROTECTION	High Voltage Cut-out (Internal)		
COMPRESSOR PROTECTION	Auto-reset Overload Protector (Internal)		
REFRIGERANT CIRCUIT PROTECTION	Auto-reset High Pressure Control Switch		
LOW WATER PROTECTION	Float Switch		
ACCESSORIES - SUPPLIED	N/A		
- REQUIRED	Ice Storage Bin, Remote Condenser Unit		
OPERATING CONDITIONS	VOLTAGE RANGE	187 - 264 V	
	AMBIENT TEMP.	45 - 100°F	
	WATER SUPPLY TEMP.	45 - 90°F	
	WATER SUPPLY PRESSURE	10 - 113 PSIG	

We reserve the right to make changes in specifications and design without prior notice.

3. KM-1600SWF3

AC SUPPLY VOLTAGE	208-230/60/3			
AMPERAGE	9.5 A (5 Min. Freeze AT 104°F / WT 80°F)			
MINIMUM CIRCUIT AMPACITY	20 A			
MAXIMUM FUSE SIZE	20 A			
APPROXIMATE ICE PRODUCTION PER 24 HR. lbs./day (kg/day) Reference without *marks	Ambient Temp.(°F)	WATER TEMP. (°F)		
		50	70	90
	70	*1500 (680)	1495 (678)	1451 (658)
	80	1496 (679)	1489 (675)	1423 (646)
	90	1495 (678)	*1484 (673)	1426 (647)
	100	1473 (668)	1470 (667)	1373 (623)
SHAPE OF ICE	Crescent Cube			
ICE PRODUCTION PER CYCLE	30.9 lbs. (14 kg) 1440 pcs.			
APPROXIMATE STORAGE CAPACITY	N/A			
ELECTRIC & WATER CONSUMPTION	90/70°F	70/50°F		
ELECTRIC W (kWH/100 lbs.)	2597 (4.2)	2563 (4.1)		
POTABLE WATER	463 (31.2)	887 (59.1)		
WATER COOLED CONDENSER gal./24HR (gal./100 lbs.)	1914 (129.0)	1005 (67.0)		
EXTERIOR DIMENSIONS (WxDxH)	48" x 27-3/8" x 27 3/8" (1219 x 695 x 695 mm)			
EXTERIOR FINISH	Stainless Steel, Galvanized Steel (Rear)			
WEIGHT	Net 310 lbs. (141 kg), Shipping 360 lbs. (163 kg)			
CONNECTIONS - ELECTRIC	Permanent - Connection			
- WATER SUPPLY	Inlet	1/2" FPT	Cond. Inlet 1/2" FPT	
- DRAIN	Outlet	3/4" FPT	Cond. Outlet 1/2" FPT	
		3/8" OD Pipe		
CUBE CONTROL SYSTEM	Float Switch			
HARVESTING CONTROL SYSTEM	Hot Gas and Water, Thermistor and Timer			
ICE MAKING WATER CONTROL	Timer Controlled. Overflow Pipe			
COOLING WATER CONTROL	Water Regulator			
BIN CONTROL SYSTEM	Thermostat			
COMPRESSOR	Hermetic, Model CS20K6E-PFV			
CONDENSER	Water-cooled, Tube in tube type			
EVAPORATOR	Vertical type, Stainless Steel and Copper			
REFRIGERANT CONTROL	Thermostatic Expansion Valve			
REFRIGERANT CHARGE	R-404A, 3 lb. 1 oz. (1400 g)			
DESIGN PRESSURE	High 427 PSIG, Low 230 PSIG			
P.C. BOARD CIRCUIT PROTECTION	High Voltage Cut-out (Internal)			
COMPRESSOR PROTECTION	Auto-reset Overload Protector (Internal)			
REFRIGERANT CIRCUIT PROTECTION	Auto-reset High Pressure Control Switch			
LOW WATER PROTECTION	Float Switch			
ACCESSORIES -SUPPLIED	N/A			
-REQUIRED	Ice Storage Bin			
OPERATING CONDITIONS	VOLTAGE RANGE	187 - 253 V		
	AMBIENT TEMP.	45 -100° F		
	WATER SUPPLY TEMP.	45 - 90° F		
	WATER SUPPLY PRESSURE	10 - 113 PSIG		

We reserve the right to make changes in specifications and design without prior notice.

4. KM-1600SRF3

AC SUPPLY VOLTAGE	208-230/60/3		
AMPERAGE	11A (5 Min. Freeze AT104°F / WT 80°F)		
MINIMUM CIRCUIT AMPACITY	20A		
MAXIMUM FUSE SIZE	20A		
APPROXIMATE ICE PRODUCTION PER 24 HR.	Ambient	WATER TEMP. (°F)	
lbs./day (kg/day)	Temp.(°F)	50	70
Reference without *marks	70	*1461 (663)	1426 (647)
	80	1434 (651)	1380 (626)
	90	1426 (647)	*1341 (608)
	100	1409 (639)	1325 (601)
SHAPE OF ICE	Crescent Cube		
ICE PRODUCTION PER CYCLE	30.9 lbs. (14 kg) 1440 pcs.		
APPROXIMATE STORAGE CAPACITY	N/A		
ELECTRIC & WATER CONSUMPTION	90/70°F	70/50°F	
ELECTRIC W (kWH/100lbs.)	2900 (5.10)	2775 (4.57)	
POTABLE WATER	452 (29.7)	773 (52.9)	
gal./24HR (gal./100 lbs.)			
EXTERIOR DIMENSIONS (WxDxH)	48" x 27-3/8" x 27-3/8" (1219 x 695 x 695 mm)		
EXTERIOR FINISH	Stainless Steel, Galvanized Steel (Rear)		
WEIGHT	Net 285 lbs. (129 kg), Shipping 360 lbs. (163 kg)		
CONNECTIONS - ELECTRIC	Permanent Connection		
- WATER SUPPLY	Inlet 1/2" FPT		
- DRAIN	Outlet 3/4" FPT		
	3/8" ID Pipe		
CUBE CONTROL SYSTEM	Float Switch		
HARVESTING CONTROL SYSTEM	Hot Gas and Water. Thermistor and Timer		
ICE MAKING WATER CONTROL	Timer Controlled. Overflow Pipe		
COOLING WATER CONTROL	N/A		
BIN CONTROL SYSTEM	Thermostat		
COMPRESSOR	Hermetic, Model CS20K6E-TF5-279		
CONDENSER	Air-cooled remote, Condenser Unit URC-20F recommended		
EVAPORATOR	Vertical type. Stainless Steel and Copper		
REFRIGERANT CONTROL	Thermostatic Expansion Valve		
	Condensing Pressure Regulator on URC-20F		
REFRIGERANT CHARGE	R-404A, 14 lbs. 12 oz. (6700 g)		
	(Ice maker 7 lbs. 1 oz. Cond. unit 7 lbs. 11 oz.)		
DESIGN PRESSURE	High 467 PSIG, Low 230 PSIG		
P.C. BOARD CIRCUIT PROTECTION	High Voltage Cut-out (Internal)		
COMPRESSOR PROTECTION	Auto-reset Overload Protector (Internal)		
REFRIGERANT CIRCUIT PROTECTION	Auto-reset High Pressure Control Switch		
LOW WATER PROTECTION	Float Switch		
ACCESSORIES - SUPPLIED	N/A		
- REQUIRED	Ice Storage Bin, Remote Condenser Unit		
OPERATING CONDITIONS	VOLTAGE RANGE	187 - 264 V	
	AMBIENT TEMP.	45 - 100°F	
	WATER SUPPLY TEMP.	45 - 90°F	
	WATER SUPPLY PRESSURE	10 - 113 PSIG	

We reserve the right to make changes in specifications and design without prior notice.

5. CONDENSING UNIT
URC-20F

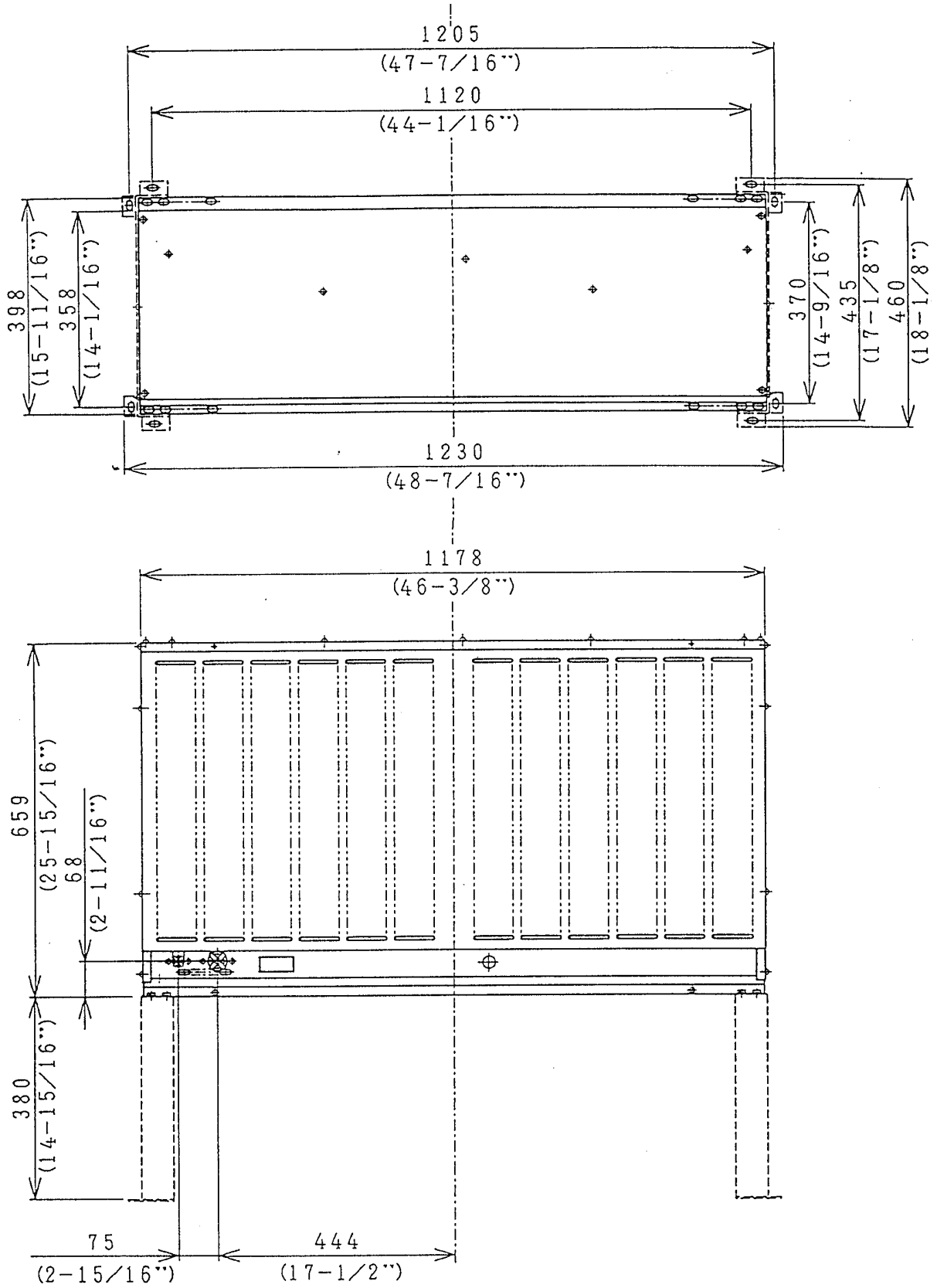

SPECIFICATIONS

MODEL: URC-20F	
EXTERIOR	Galvanized Steel
DIMENSIONS (W x D x H)	46 - 3/8" x 15 - 11/16" x 25 - 15/16" (1178 x 398 x 659 mm)
REFRIGERANT CHARGE	R404A 7 lbs.11 oz. (3500 g)
URC-20F	Net 104 lbs. (47 kg)
WEIGHT	Shipping 150 lbs. (52 kg)
CONNECTIONS	One Shot Couplings (Aeroquip)
REFRIGERANT	Permanent Connection
ELECTRICAL	Air-cooled
CONDENSER	Condensing Pressure Regulator
HEAD PRESSURE CONTROL	Min. -20°F - Max. +122°F
AMBIENT CONDITION	(-29°C to +50°C) Outdoor use

II. GENERAL INFORMATION

1. CONSTRUCTION

[a] KM-1600SWF, KM-1600SWF3

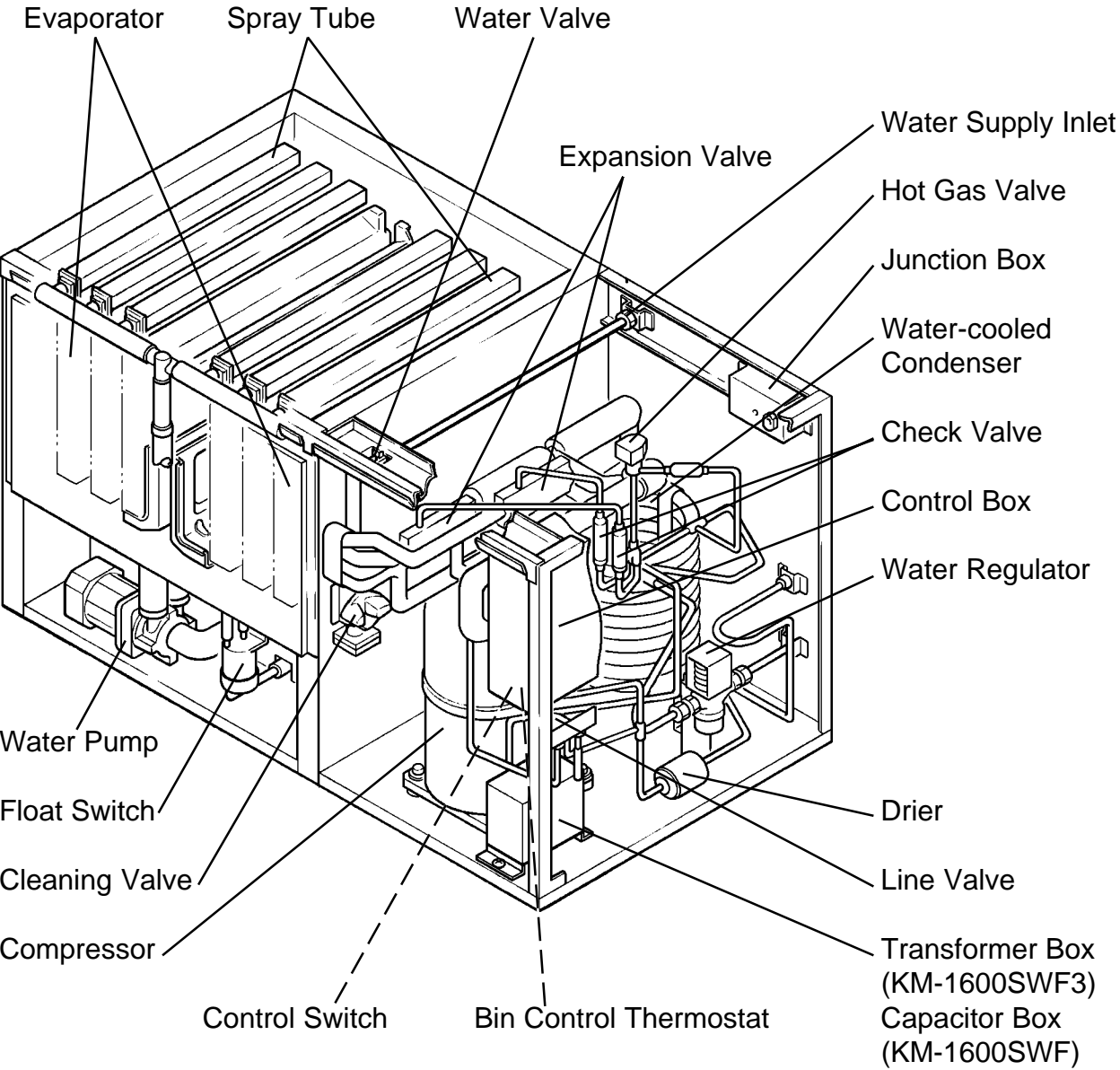

[b] KM-1600SRF, KM-1600SRF3

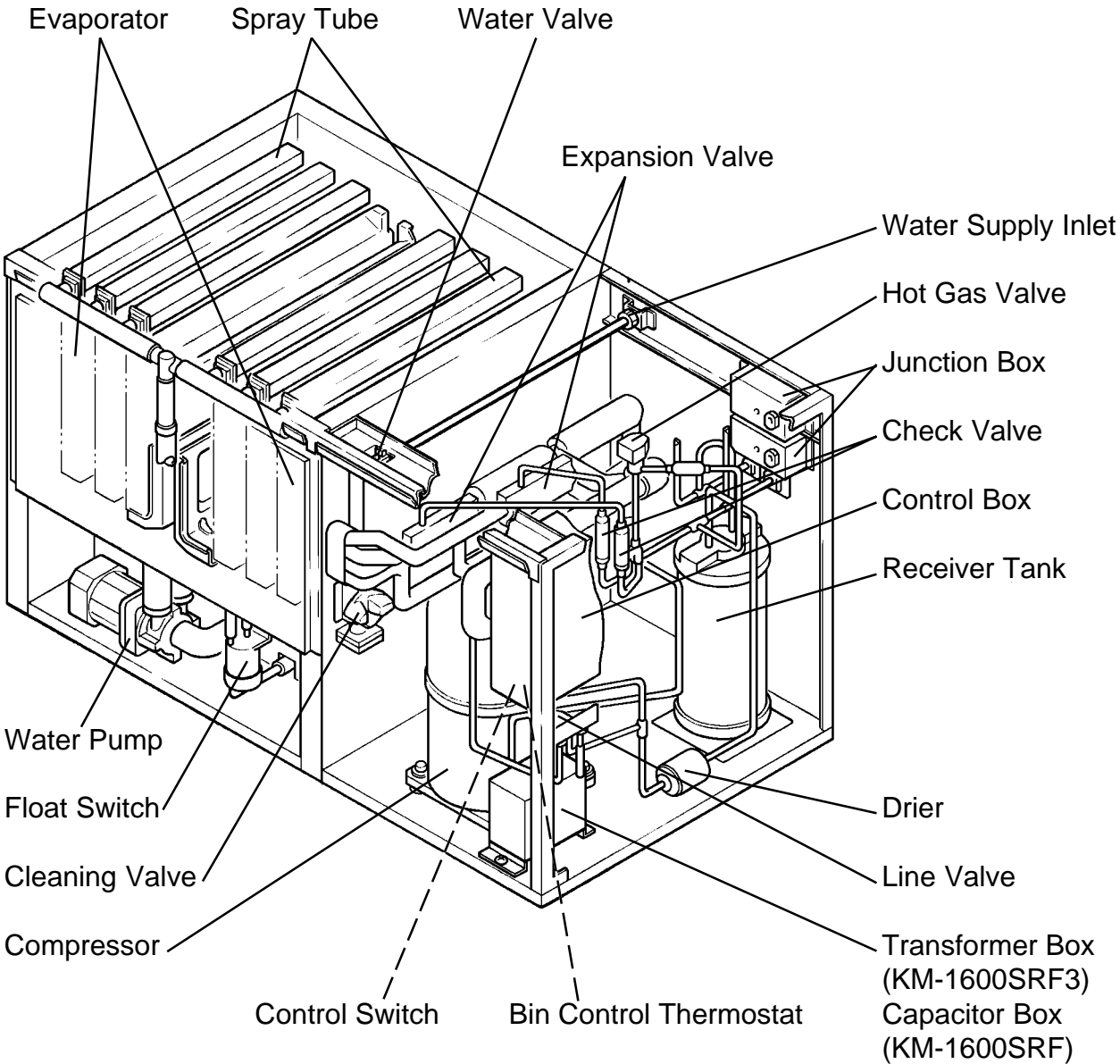

2. CONTROLLER BOARD

[a] SOLID-STATE CONTROL

- 1) A HOSHIZAKI exclusive solid-state control is employed in KM-2000SWF3 and KM-2000MRF3 Stackable Crescent Cubers.
- 2) A Printed Circuit Board (hereafter called "Controller Board") includes a stable and high quality control system.
- 3) All models are pretested and factory-adjusted.

[b] CONTROLLER BOARD

CAUTION

1. Fragile, handle very carefully.
2. A controller board contains integrated circuits, which are susceptible to failure due to static discharge. It is especially important to touch the metal part of the unit when handling or replacing the board.
3. Do not touch the electronic devices on the board or the back of the board to prevent damage to the board.
4. Do not change wiring and connections. Do not misconnect K3, K4 and K5, because the same connector is used for the Thermistor and Float Switch. K4 is not connected.
5. Always replace the whole board assembly when it goes bad.
6. Do not short out power supply to test for voltage.

PART NUMBER

TYPE

2A0836-01	HOSIZAKI-001 (Control Products - 8 Pin)
or 2A1410-01	HOS-001A (Control Products - 10 Pin)

Features of Control Products "E" Controller Board

- 1) Maximum Water Supply Period - 6 minutes

Water Solenoid Valve opening, in the Defrost (Harvest) Cycle, is limited by the defrost timer. The Water Valve cannot remain open longer than the maximum period. The Water Valve can close in less than six minutes if the defrost cycle is completed.

2) Defrost Timer

The defrost cycle starts when the Float Switch opens and completes the freeze cycle. But the Defrost Timer does not start counting until the Thermistor senses 48°F at the Evaporator outlet. The period from the end of the freeze cycle up to the point of the Thermistor's sensing varies depending on the ambient and water temperatures.

3) High Temperature Safety - $127 \pm 7^\circ\text{F}$

The temperature of the suction line in the refrigerant circuit is limited by the High Temperature Safety.

During the defrost cycle the Evaporator temperature rises. The Thermistor senses 48°F and starts the Defrost Timer. After the Defrost Timer counts down to zero, the normal freeze cycle begins. If the Evaporator temperature continues to rise, the Thermistor will sense the rise in temperature and at $127 \pm 7^\circ\text{F}$ the Thermistor operates the High Temperature Safety.

This High Temperature Safety shuts down the circuit and the icemaker automatically stops. To reset the safety, turn the power off and back on again.

This High Temperature Safety protects the unit from excessive temperature. The Control Board will Beep every 3 seconds. The white Reset Button on the Control Board must be pressed with power on to reset the Safety.

4) Low Water Safety

If the Pump Motor is operated without water, the mechanical seal can fail. To prevent this type of failure, the Controller Board checks the position of the Float Switch at the end of the initial one minute water fill cycle and at the end of each defrost cycle.

If the Float Switch is in the up position (electrical circuit closed), the Controller Board changes to the ice making cycle. If the Float Switch is in the down position (electrical circuit open), the Controller Board changes to a one minute water fill cycle before starting the ice making cycle. This method allows for a Low Water Safety shut down to protect the Water Pump from mechanical seal failure.

For water-cooled model, if the water is shut off, the unit is protected by the High Pressure Switch.

5) High Voltage Cut-out

The maximum allowable supply voltage of this icemaker is limited by the High Voltage Cut-out.

If miswiring (especially on single phase 3 wire models) causes excessive voltage on the Controller Board, the High Voltage Cut-out shuts down the circuit in 3 seconds and the icemaker automatically stops. When the proper supply voltage is resumed, the icemaker automatically starts running again. The Control Board will signal this problem using 7 Beeps every 3 seconds.

6) LED Lights and Audible Alarm Safeties

The red LED indicates proper control voltage and will remain on unless a control voltage

problem occurs. At startup a 5 second delay occurs while the board conducts an internal timer check. A short beep occurs when the power switch is turned ON or OFF.

The green LED's 1-4 represent the corresponding relays and energize and sequence 5 seconds from initial startup as follows:

Sequence Step	LED's on Length:	Min.	Max.	Avg.
1 Minute Fill Cycle	LED4			60 sec.
Harvest Cycle	LED1, 4, & 2	2 min.	20 min.	3-5 min.
Freeze Cycle	LED1	5 min.	60 min.	30-35 min.
Reverse Pump Out	LED1, 3, & 2	10 sec.	20 sec.	Factory set.

{LED 1 – Comp; LED 2 - HGV/CFM; LED 3 – PM; LED 4 - WV}

The built in safeties shut down the unit and have alarms as follows:

1 beep every 3 sec. = **High Evaporator Temperature** >127 ° F.

Check for defrost problem (stuck HGV or relay), hot water entering unit, stuck headmaster, or shorted thermistor.

2 beeps every 3 sec. = **Defrost Back Up Timer**. Defrost >20 minutes.

Orange LED marked 20 MIN energizes.

Check for open thermistor, HGV not opening, TXV leaking by, low charge, or inefficient compressor.

3 beeps every 3 sec. = **Freeze Back Up Timer**. Freeze > 60 minutes.

Yellow LED marked 60 MIN energizes.

Check for F/S stuck closed (up), WV leaking by, HGV leaking by, TXV not feeding properly, low charge, or inefficient compressor.

To manually reset the above safeties, depress white alarm reset button with the power supply ON.

6 beeps every 3 sec. = **Low Voltage**. Voltage is 92 Vac or less.

7 beeps every 3 sec. = **High Voltage**. Control voltage > 147Vac ±5%.

The red LED will de-energize if voltage protection operates.

The voltage safety automatically resets when voltage is corrected.

The **Output Test** switch “S3” provides a relay sequence test. With power OFF, place S3 ON and switch power to ICE. The correct lighting sequence should be none, 2, 3, 4, 1, & 4, normal sequence every 5 seconds. S3 should remain in the “OFF” position for normal operation.

The application switch located between relay X3 & X4 must be set to match the original board application. Place this switch in the ALP position if there is no white wire supplied

to the K1 connector. If there is a white wire, place the switch in the C position. If this switch is placed in the wrong position either the compressor contactor will remain energized with the control switch OFF or the unit will not start.

The dip switches should be adjusted per the adjustment chart published in the Tech Specs book. 7 & 8 must remain in the OFF position.

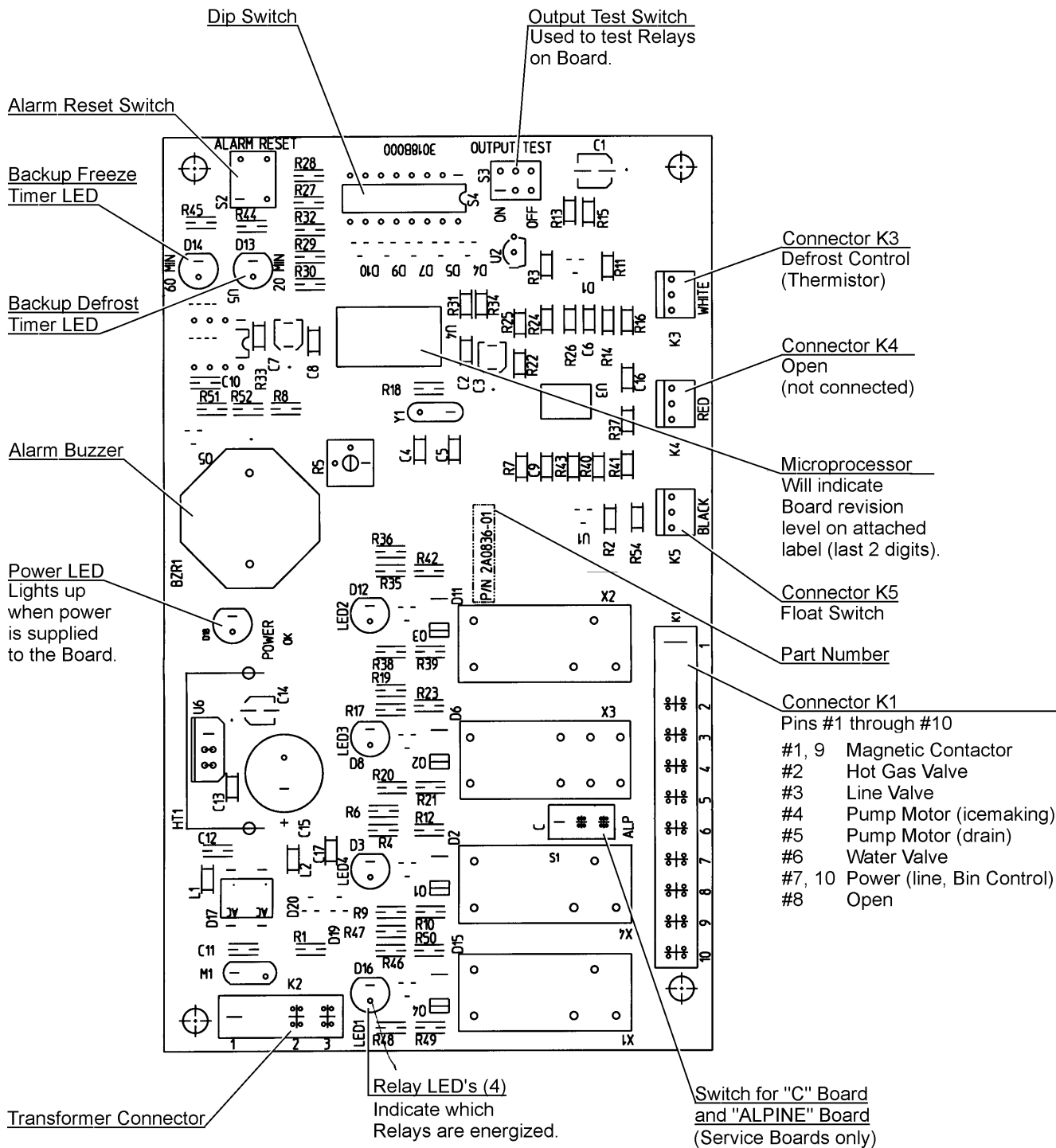

(Control Products HOSHIZAKI001 Board)

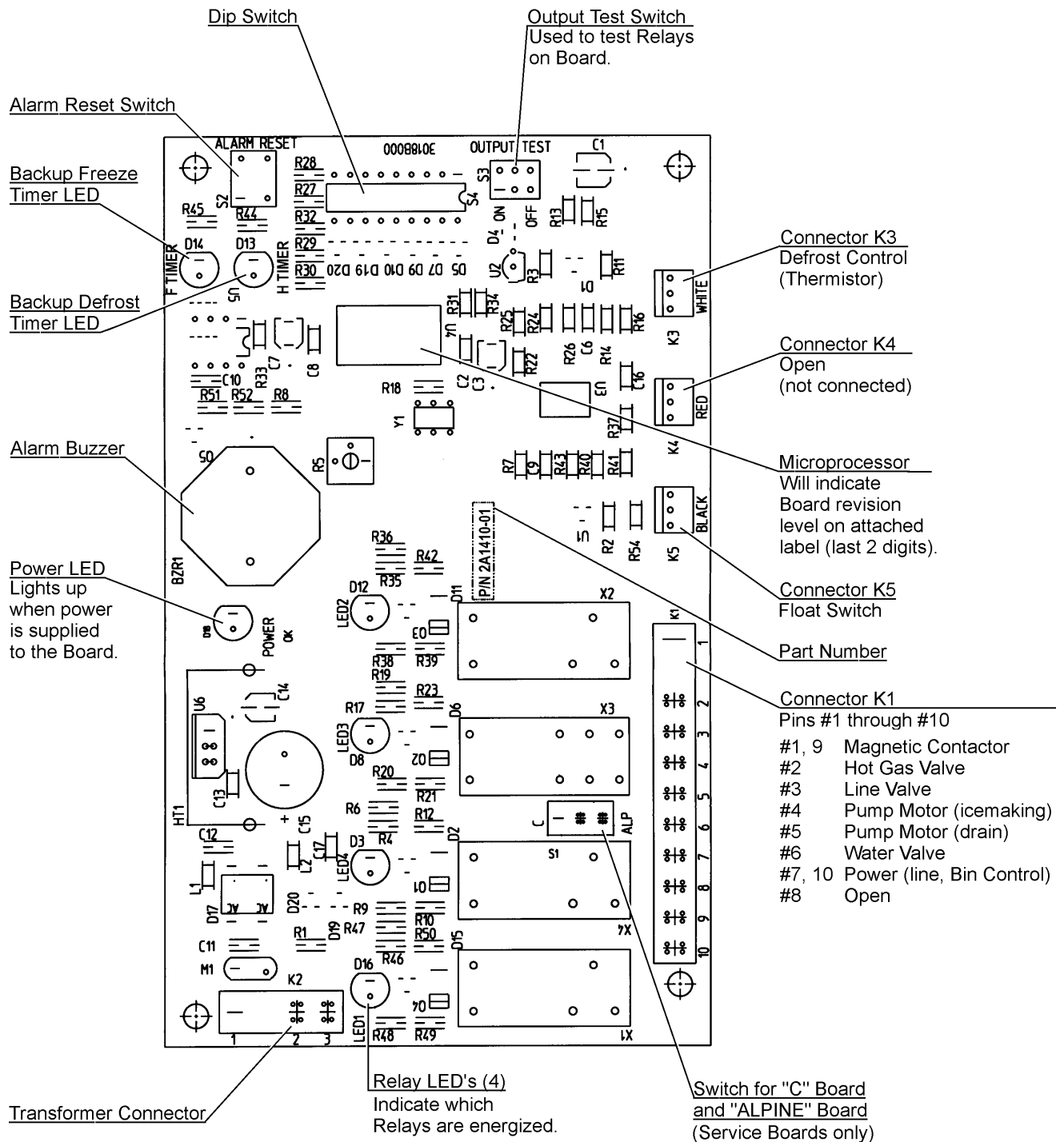

(Control Products HOS-001A Board)

[c] SEQUENCE

1st Cycle [KM-1600SWF, KM-1600SWF3, KM-1600SRF and KM-1600SRF3]

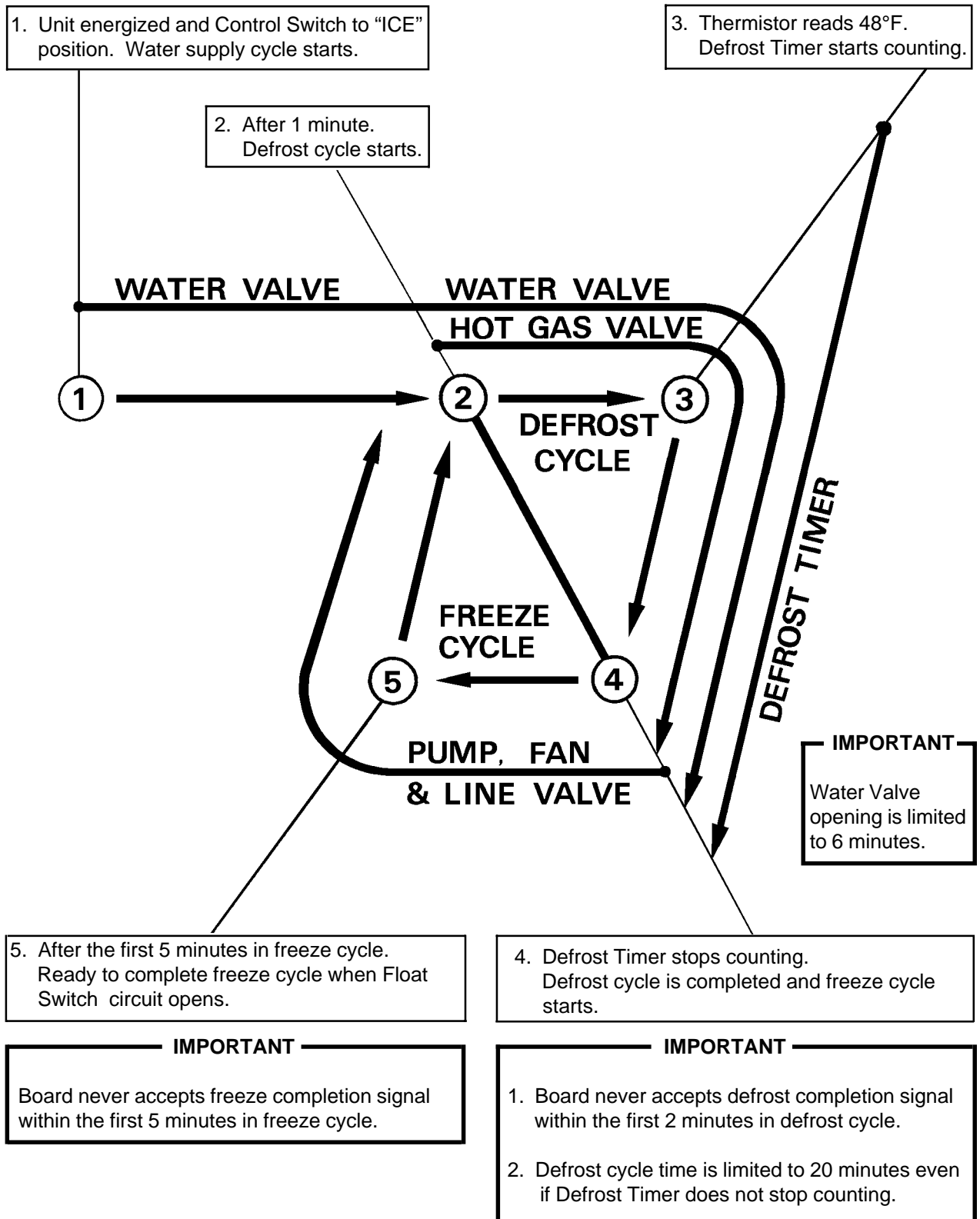

2nd Cycle and after with pump drain [KM-1600SWF, KM-1600SWF3, KM-1600SRF and KM-1600SRF3]

IMPORTANT
Freeze cycle time is limited to 60 minutes even if Float Switch does not open.

1. Float Switch opens and signals to complete freeze cycle.
Drain timer starts counting.

2. Drain timer stops counting.
Pump drain is completed

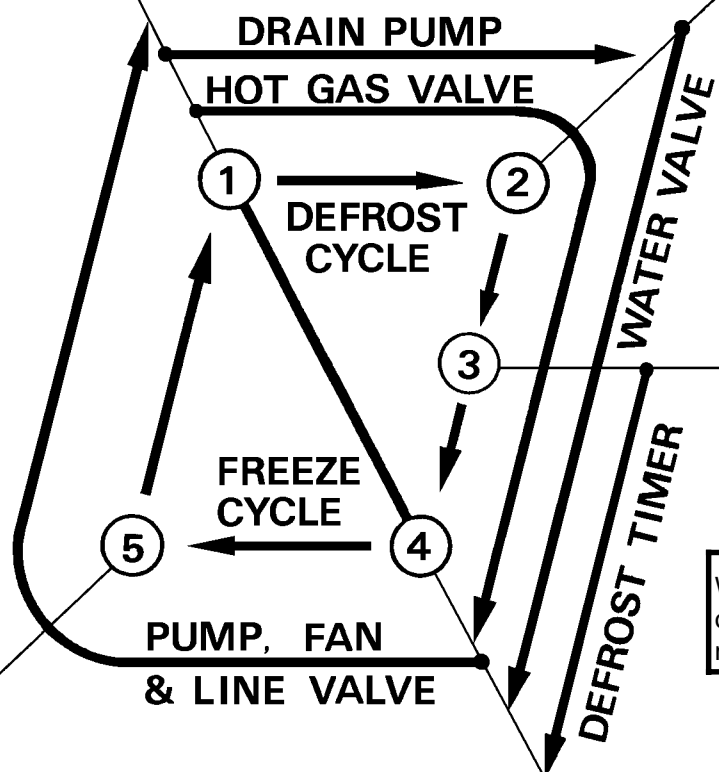

3. Thermistor reads 48° F.
Defrost Timer starts counting.

IMPORTANT
Water Valve opening is limited to 6 minutes.

5. After the first 5 minutes in freeze cycle.
Ready to complete freeze cycle when Float Switch circuit opens.

4. Defrost Timer stops counting.
Defrost cycle is completed and freeze cycle starts.

IMPORTANT
Board never accepts freeze completion signal within the first 5 minutes in freeze cycle.

IMPORTANT
1. Board never accepts defrost completion signal within the first 2 minutes in defrost cycle.
2. Defrost cycle time is limited to 20 minutes even if Defrost Timer does not stop counting.

2nd Cycle and after with no pump drain [KM-1600SWF, KM-1600SWF3, KM-1600SRF and KM-1600SRF3]

IMPORTANT
Freeze cycle time is limited to 60 minutes even if Float Switch does not open.

1. Float Switch opens and signals to complete freeze cycle.

2. Thermistor reads 48° F. Defrost Timer starts counting.

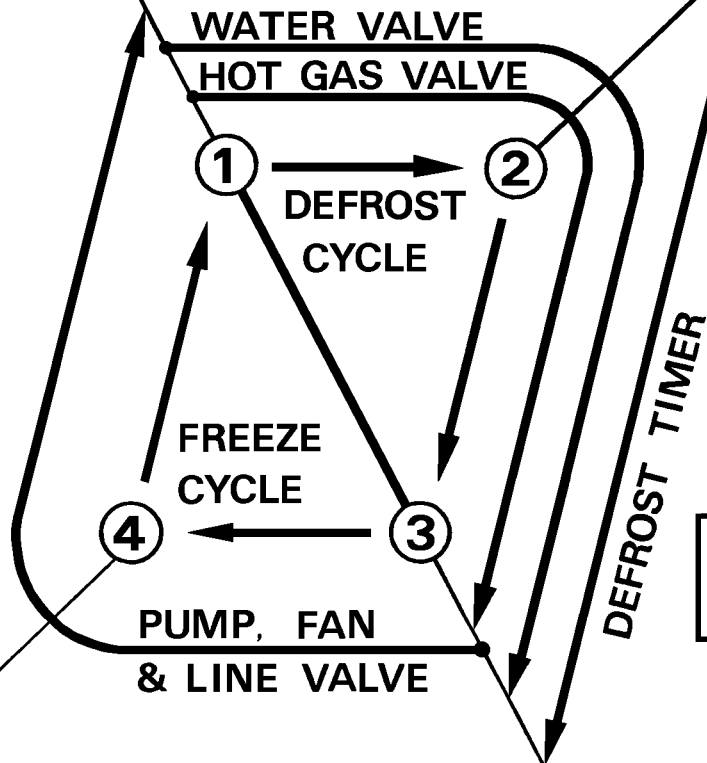

IMPORTANT
Water Valve opening is limited to 6 minutes.

4. After the first 5 minutes in freeze cycle. Ready to complete freeze cycle when Float Switch circuit opens.

3. Defrost Timer stops counting. Defrost cycle is completed and freeze cycle starts.

IMPORTANT
Board never accepts freeze completion signal within the first 5 minutes in freeze cycle.

IMPORTANT
1. Board never accepts defrost completion signal within the first 2 minutes in defrost cycle.
2. Defrost cycle time is limited to 20 minutes even if Defrost Timer does not stop counting.

[d] CONTROLS AND ADJUSTMENTS

The Dip Switch is factory-adjusted to the following positions:

DIP SWITCH NO.	1	2	3	4	5	6	7	8	9	10
KM-1600SWF, SWF3	OFF	OFF	ON	ON	ON	ON	OFF	OFF	OFF	ON
KM-1600SRF, SRF3	ON	OFF	ON	ON	ON	ON	OFF	OFF	OFF	OFF

Switch Nos. 1 and 2:

Used for adjustment of the Defrost Timer.

The Defrost Timer starts counting when the Thermistor reads a certain temperature at the Evaporator outlet.

Switch Nos. 3 and 4:

Used for adjustment of the Drain Timer.

When a freeze cycle is completed, the Pump Motor stops, and the icemaker resumes operation in 2 seconds. Then the Pump Motor drains the Water Tank for the time determined by the Drain Timer. The Drain Timer also determines the time to restrain completion of a defrost cycle, i.e. the minimum defrost time.

Switch Nos. 5 and 6:

Used for adjustment of the Drain Counter.

The Pump Motor drains the Water Tank at the frequency determined by the Drain Counter.

Switch Nos. 7 and 8:

Used only for checking the Controller Board. Usually set in OFF position.

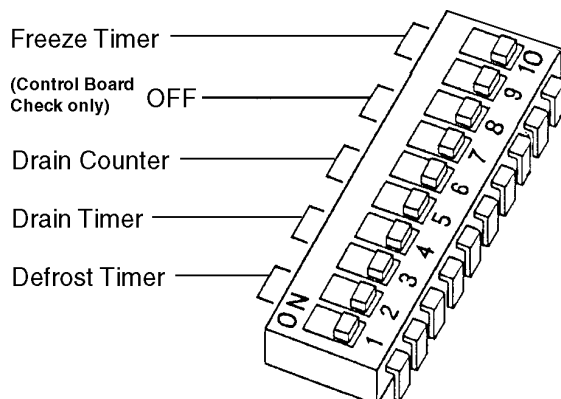

Switch Nos. 9 and 10:

Used for adjustment of Freeze Timer.

The Freeze Timer determines maximum freeze cycle time. Upon termination of Freeze Timer, machine initiates the harvest cycle. After 2 consecutive timer terminations, machine will shut down, possibly indicating a problem.

1) Defrost Control

A thermistor (Semiconductor) is used for a defrost control sensor. The resistance varies depending on the Suction Line temperatures. The Thermistor detects the temperature of the Evaporator outlet to start the Defrost Timer. No adjustment is required. If necessary, check for resistance between Thermistor leads, and visually check the Thermistor mounting, located on the Suction Line next to the Evaporator outlet.

Temperature (°F)	Resistance (kΩ)
0	14.401
10	10.613
32	6.000
50	3.871
70	2.474
90	1.633

Check a thermistor for resistance by using the following procedures.

- (i) Disconnect the connector K3 on the board.
- (ii) Remove the Thermistor. See “V. 11. REMOVAL AND REPLACEMENT OF THERMISTOR.”
- (iii) Immerse the Thermistor sensor portion in a glass containing ice and water for 2 or 3 minutes.
- (iv) Check for a resistance between Thermistor leads.
Normal reading is within 3.5 to 7 kΩ. Replace the Thermistor if it exceeds the normal reading.

2) Defrost Timer

No adjustment is required under normal use, as the Defrost Timer is adjusted to the suitable position. However, if necessary when all the ice formed on the Evaporator does not fall into the bin in the harvest cycle, adjust the Defrost Timer to a longer setting by adjusting the Dip Switch (No. 1 & 2) on the Controller Board.

SETTING		TIME
Dip Switch No. 1	Dip Switch No. 2	
OFF	OFF	60 seconds
ON	OFF	90 seconds
OFF	ON	120 seconds
ON	ON	180 seconds

3) Drain Timer

The Drain Timer is factory-adjusted, and no adjustment is required.

SETTING		TIME	
Dip Switch No. 3	Dip Switch No. 4	T1	T2
OFF	OFF	10 seconds	150 seconds
ON	OFF	10 seconds	180 seconds
OFF	ON	10 seconds	120 seconds
ON	ON	20 seconds	180 seconds

T1: Time to drain the Water Tank

T2: Time to restrain defrost completion

4) Drain Counter

CAUTION

Do not adjust the Drain Counter, or the Evaporator may freeze up.

The Drain Counter is factory-adjusted to drain the Water Tank every 10 cycles, and no adjustment is required. However, where water quality is bad and the icemaker needs a pump drain more often, the Drain Counter can be adjusted as shown in the table below:

SETTING		FREQUENCY
Dip Switch No. 5	Dip Switch No. 6	
OFF	OFF	every cycle
ON	OFF	every 2 cycles
OFF	ON	every 5 cycles
ON	ON	every 10 cycles

5) Freeze Timer

CAUTION

Adjust to proper specification, or the unit may not operate correctly.

Two new dip switches numbered 9 and 10 have been added to the improved “E” board to better prevent possible freeze ups. These settings come factory set to the default setting of 60 min. (OFF, OFF). Check the adjustment chart published in the Tech Specs for proper settings. If the old board does not have these two dip switches, (only 8 instead of 10), leave setting as OFF, OFF.

SETTING		TIME
Dip Switch No. 9	Dip Switch No. 10	
OFF	OFF	60 min.
ON	OFF	70 min.
OFF	ON	50 min.
ON	ON	60 min.

6) Bin Control

CAUTION

When the ambient temperature is below 45°F, the Bin Control Thermostat operates to stop the icemaker even if the Ice Storage Bin is empty. When the Thermostat is set in the prohibited range, the icemaker operates continuously even if the Ice Storage Bin is filled with ice. Setting in the prohibited range might cause severe damage to the icemaker resulting in failure.

No adjustment is required under normal use, as the Bin Control is factory-adjusted. Adjust it, if necessary, so that the icemaker stops automatically within 10 seconds after ice contacts the Bin Control Thermostat Bulb.

[e] CHECKING THE CONTROLLER BOARD

- 1) Visually check the sequence with the icemaker operating.
- 2) Visually check the Controller Board by using the following procedures.
 - (i) Adjust the Defrost Timer to minimum position.
Disconnect the Thermistor from the Controller Board.
Connect a 1.5 k Ω - 3.5 k Ω resistor to the Connector K3 (pins #1 and #2), and energize the unit.

After the 1 minute \pm 5 second water supply cycle and the 2 minute \pm 10 second defrost cycle, the unit should start the freeze cycle.

- (ii) After the above step (i), disconnect the Float Switch leads from the Controller Board within the first 5 minutes of the freeze cycle.

The unit should go into the defrost cycle after the first 5 minutes \pm 20 seconds of the freeze cycle.

- (iii) Reconnect the Float Switch Connector to the Controller Board. After the first 5 minutes of the freeze cycle, disconnect the Float Switch leads from the Controller Board.

At this point, the unit should start the defrost cycle.

- (iv) After Step (iii), de-energize the unit and confirm that the Defrost Timer is in the minimum position. Disconnect the resistor from the Controller Board, and energize the unit.

After the 1 minute water supply cycle, the defrost cycle starts.

Re-connect a 1.5 k Ω - 3.5 k Ω resistor to the Connector K3 (pins #1 and #2) after the first 2 minutes of the defrost cycle.

The unit should start the freeze cycle after 1 minute \pm 5 seconds from the resistor connection.

3) Check the Controller Board by using test program of the Controller Board.

The Output Test Switch "S3" provides a relay sequence test. With power OFF, place S3 ON and switch power to ICE. The correct lighting sequence should be none, 2, 3, 4, 1, and 4, normal sequence every 5 seconds. S3 should remain in the "OFF" position for normal operation.

III. TECHNICAL INFORMATION

1. WATER CIRCUIT AND REFRIGERANT CIRCUIT

[a] KM-1600SWF, KM-1600SWF3

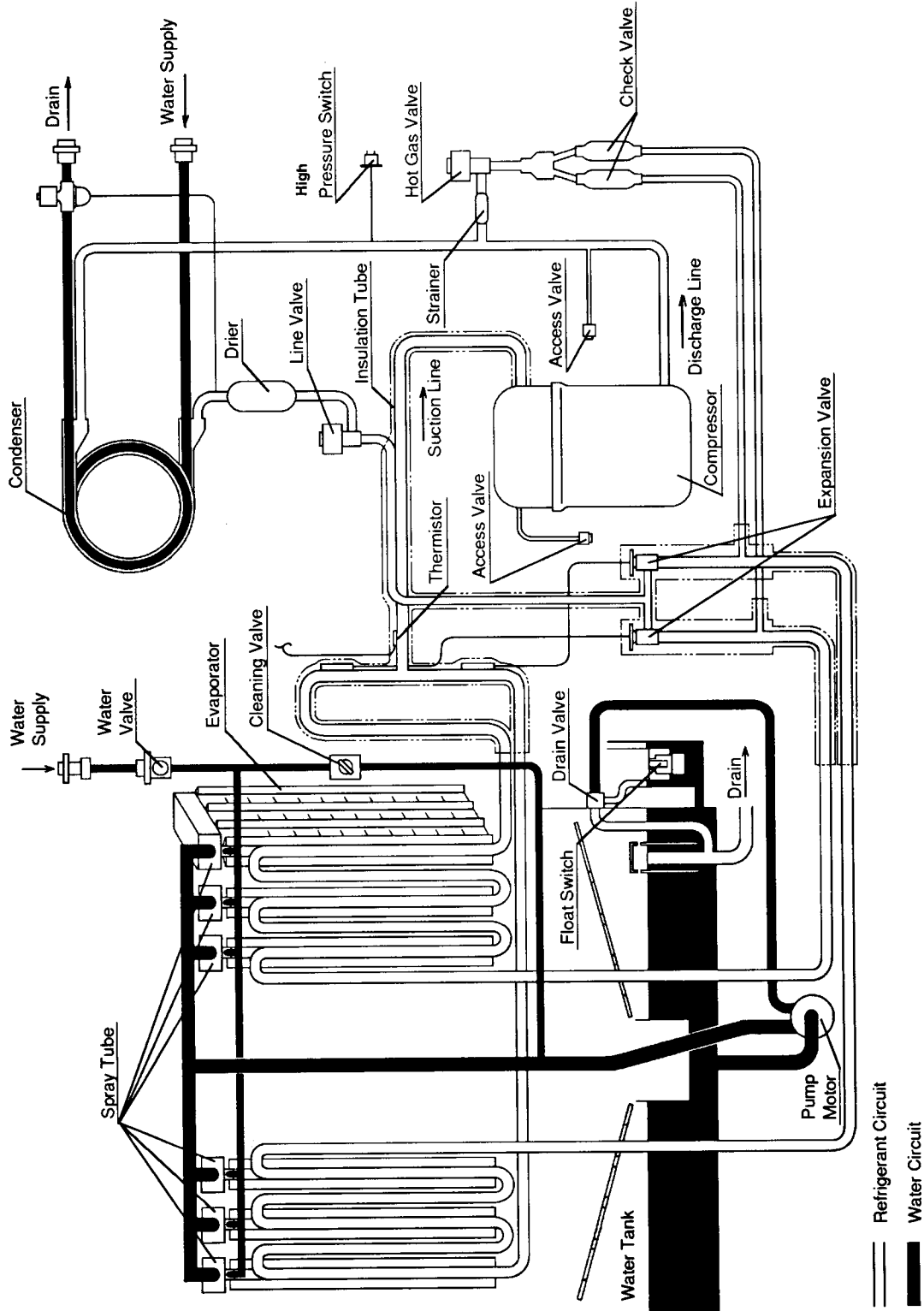

[b] KM-1600SRF, KM-1600SRF3

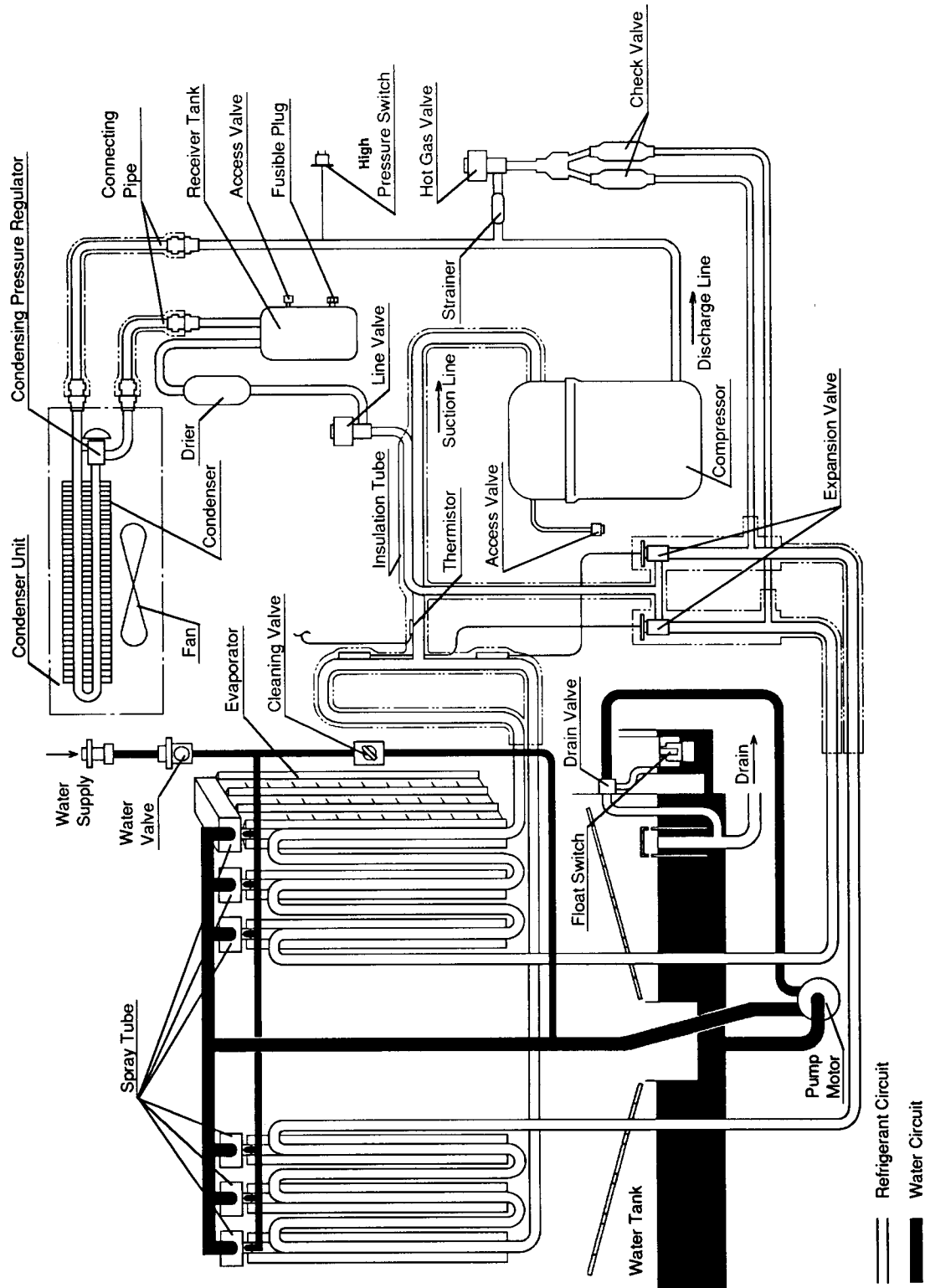

2. WIRING DIAGRAMS

KM-1600SWF, KM-1600SRF

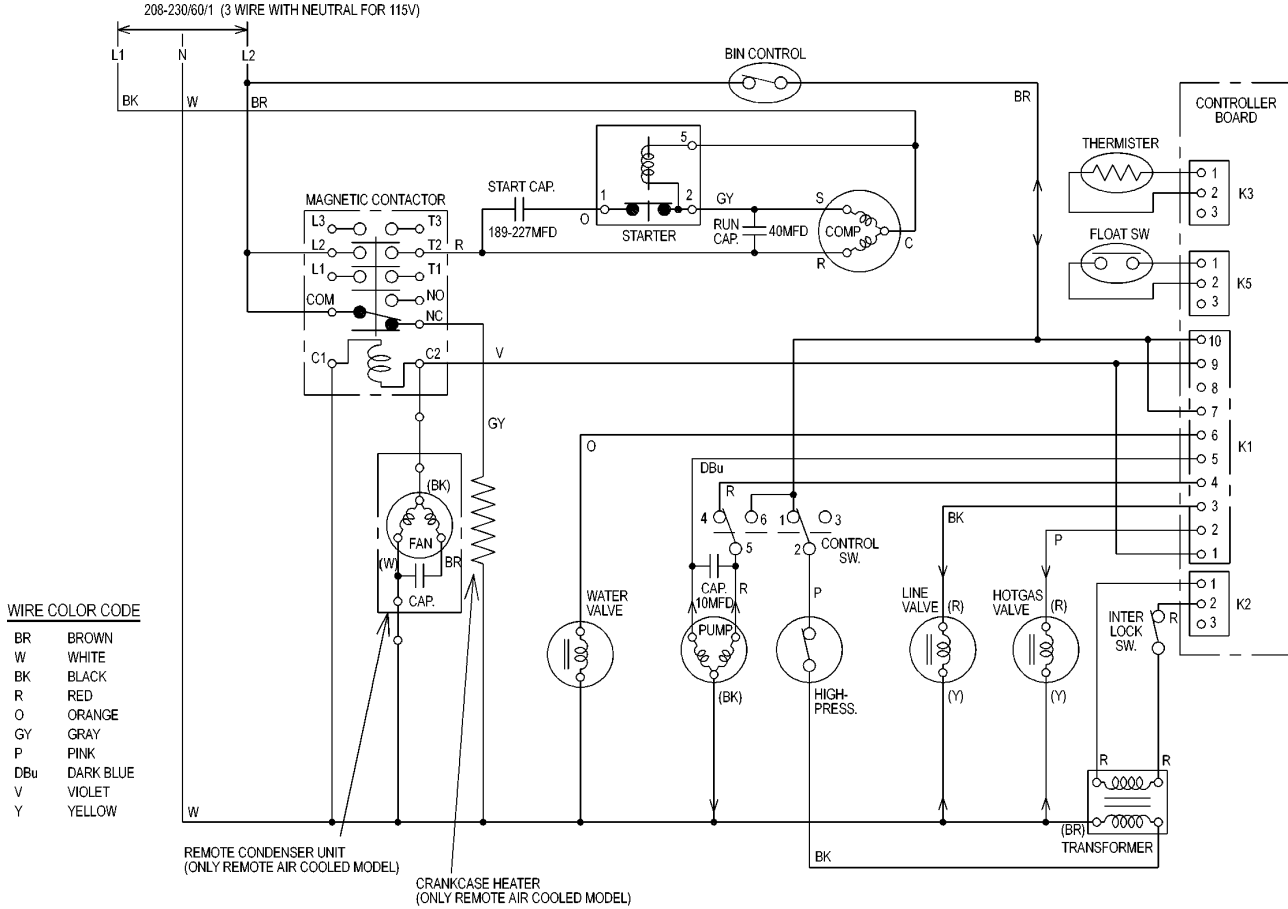

KM-1600SWF

Pressure Switch

Cut-out $384 \begin{matrix} +21.3 \\ -0 \end{matrix}$ PSIG

Cut-in 284 ± 21.3 PSIG

KM-1600SRF

Pressure Switch

Cut-out $412 \begin{matrix} +21.3 \\ -0 \end{matrix}$ PSIG

Cut-in 327 ± 21.3 PSIG

KM-1600SWF3, KM-1600SRF3

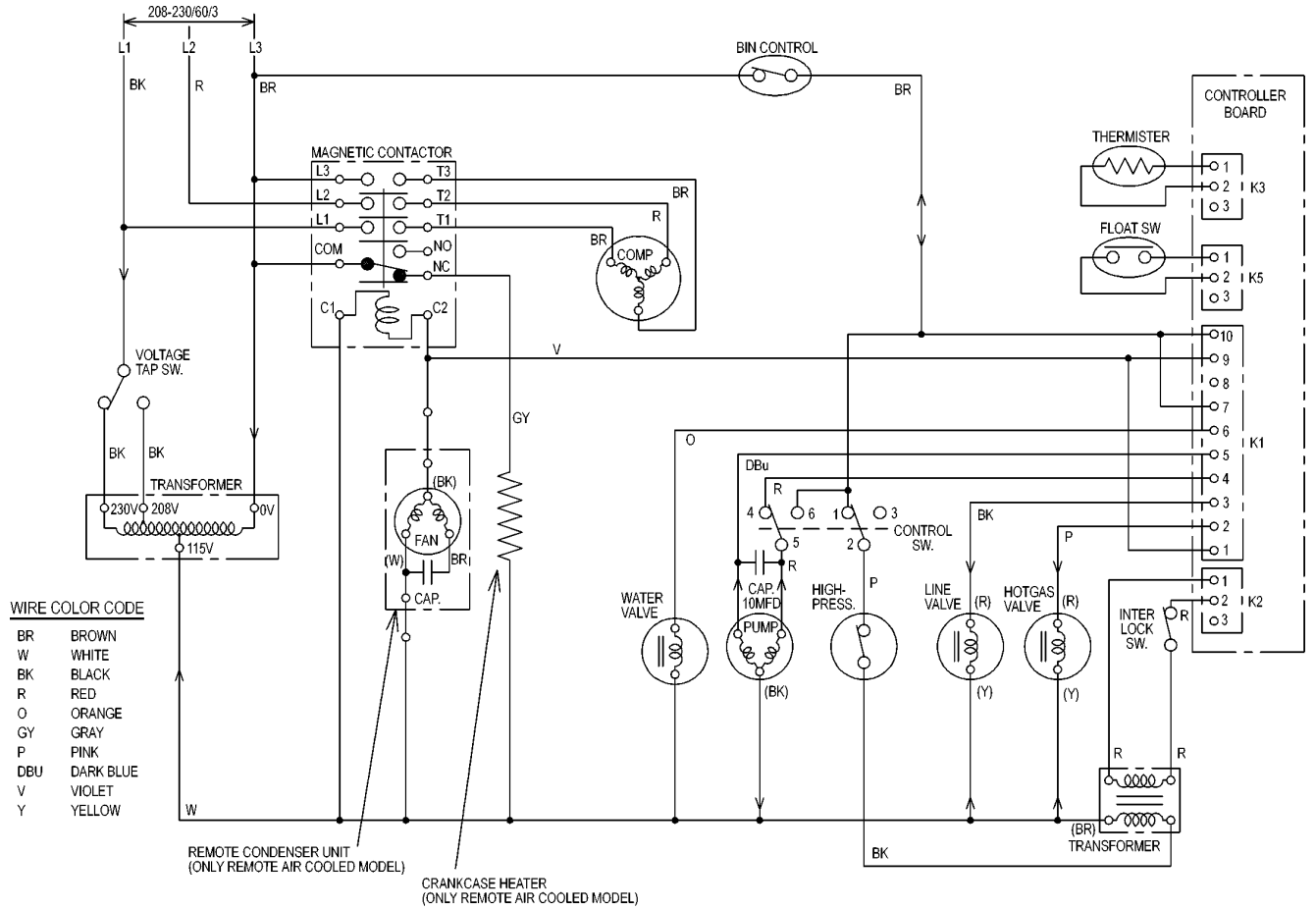

KM-1600SRF3

Pressure Switch

Cut-out $384 \begin{matrix} +21.3 \\ -0 \end{matrix}$ PSIG

Cut-in 284 ± 21.3 PSIG

KM-1600SRF3

Pressure Switch

Cut-out $412 \begin{matrix} +21.3 \\ -0 \end{matrix}$ PSIG

Cut-in 327 ± 21.3 PSIG

3. TIMING CHART KM-1600SWF, SWF3, SRF, SRF3

When Control Sw. is turned OFF, Pressure Sw. is OFF, or Thermistor Temp. exceeds t1.

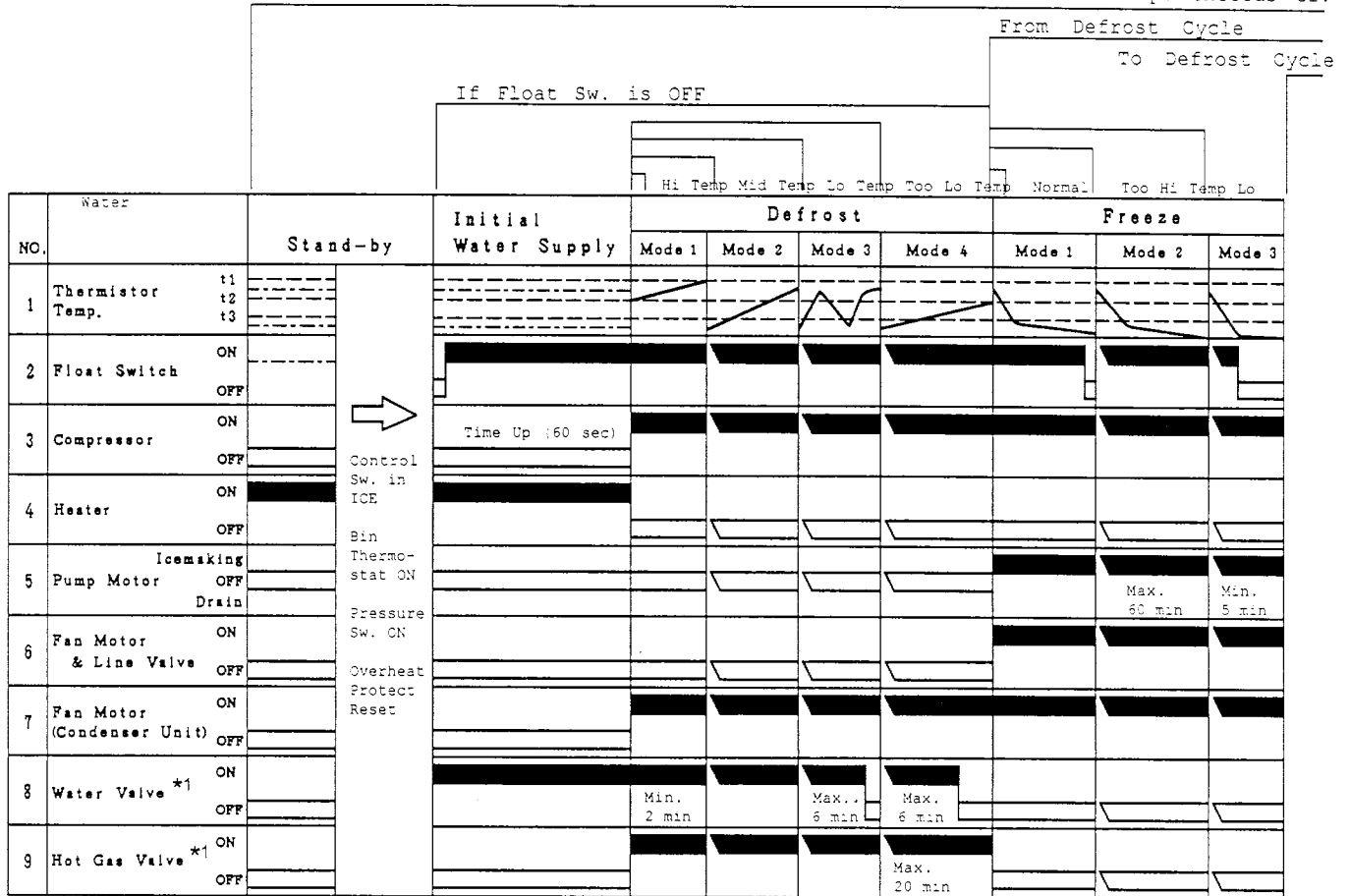

*1 The icemaker does not complete a defrost cycle in the first 2 or 3 minutes. See "II. 2. [d] CONTROLS AND ADJUSTMENTS."

To Stand-by Cycle (When Control Sw. is turned OFF, Pressure Sw. is OFF, or Thermistor Temp. exceeds t1.)

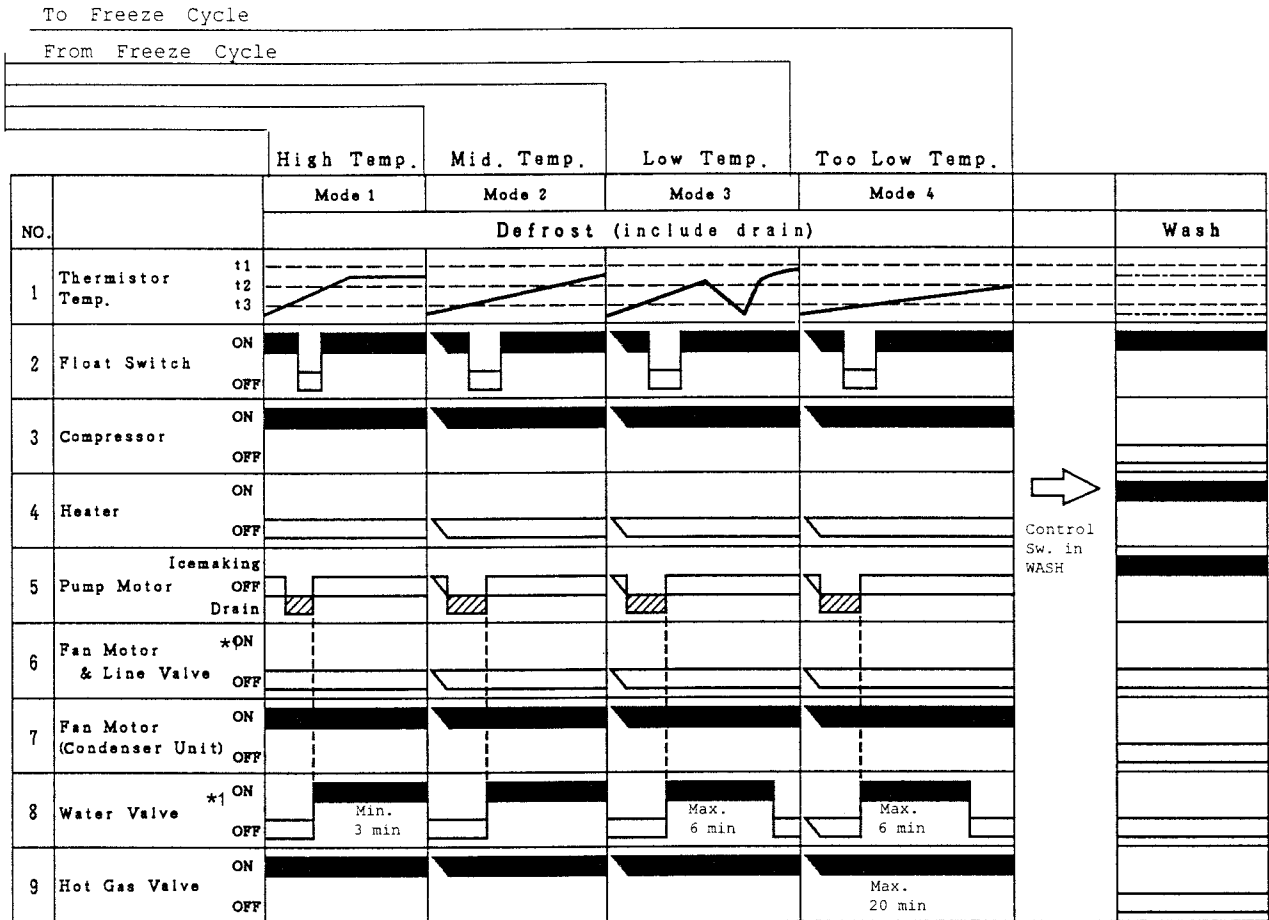

*1 The icemaker does not complete a defrost cycle in the first 2 or 3 minutes. See "II. 2. [d] CONTROLS AND ADJUSTMENTS."

4. PERFORMANCE DATA

[a] KM-1600SWF

APPROXIMATE ICE PRODUCTION PER 24 HR.	AMBIENT TEMP. (°F/°C)	WATER TEMP. (°F/°C)					
		50/10		70/21		90/32	
	70/21	1583	<u>718</u>	1555	<u>705</u>	1467	<u>666</u>
	80/27	1562	<u>708</u>	1518	<u>688</u>	1403	<u>636</u>
	90/32	1555	<u>705</u>	1487	<u>674</u>	1382	<u>627</u>
lbs./day kg./day	100/38	1521	<u>690</u>	1462	<u>663</u>	1285	<u>583</u>
APPROXIMATE ELECTRIC CONSUMPTION	70/21	2510		2537		2562	
	80/27	2531		2572		2592	
	90/32	2537		2602		2624	
watts	100/38	2538		2607		2645	
APPROXIMATE WATER CONSUMPTION PER 24 HR.	70/21	1840	<u>6.97</u>	2029	<u>7.68</u>	2684	<u>10.16</u>
	80/27	1984	<u>7.51</u>	2277	<u>8.62</u>	3153	<u>11.93</u>
	90/32	2029	<u>7.68</u>	2484	<u>9.40</u>	3280	<u>12.42</u>
gal./day m ³ /day	100/38	2293	<u>8.68</u>	2671	<u>10.11</u>	4012	<u>15.19</u>
FREEZING CYCLE TIME	70/21	23		24		25	
	80/27	24		25		26	
	90/32	24		26		27	
min.	100/38	24		26		28	
HARVEST CYCLE TIME	70/21	5.0		4.5		4.0	
	80/27	4.5		3.5		3.0	
	90/32	4.5		2.5		2.0	
min.	100/38	4.5		2.5		2.0	
HEAD PRESSURE	70/21	265	<u>18.6</u>	266	<u>18.7</u>	271	<u>19.0</u>
	80/27	266	<u>18.7</u>	268	<u>18.9</u>	274	<u>19.3</u>
	90/32	266	<u>18.7</u>	270	<u>19.0</u>	275	<u>19.4</u>
PSIG kg/cm ² G	100/38	268	<u>18.9</u>	271	<u>19.1</u>	280	<u>19.7</u>
SUCTION PRESSURE	70/21	38	<u>2.7</u>	39	<u>2.7</u>	41	<u>2.9</u>
	80/27	38	<u>2.7</u>	39	<u>2.8</u>	42	<u>3.0</u>
	90/32	39	<u>2.7</u>	40	<u>2.8</u>	43	<u>3.0</u>
PSIG kg/cm ² G	100/38	39	<u>2.8</u>	41	<u>2.9</u>	45	<u>3.2</u>
TOTAL HEAT OF REJECTION FROM CONDENSER	18000 BTU/h [AT 90°F (32°C) / WT 70°F (21°C)]						
TOTAL HEAT OF REJECTION FROM COMPRESSOR	3200 BTU/h [AT 90°F (32°C) / WT 70°F (21°C)]						
WATER FLOW FOR CONDENSER	165 gal. / h [AT 100°F (38°C) / WT 90°F (32°C)]						
PRESSURE DROP OF COOLING WATER LINE	less than 10 PSIG						

Note: Pressure data is recorded at 5 minutes into freezing cycle.
The data not in **bold** should be used for reference only.

* We reserve the right to make changes in specifications and design without prior notice.

[b] KM-1600SRF

APPROXIMATE ICE PRODUCTION PER 24 HR.	Ambient Temp. (°F/°C)	Water Temp. (°F/°C)		
		50/10	70/21	90/32
	70/21	*1430 (649)	1415 (642)	1343 (609)
	80/27	1419 (644)	1396 (633)	1295 (588)
	90/32	1415 (642)	*1380 (626)	1290 (585)
lbs./day (kg/day)	100/38	1383 (628)	1359 (616)	1207 (547)
APPROXIMATE ELECTRIC CONSUMPTION	70/21	*2815	2859	2906
	80/27	2848	2817	2957
	90/32	2859	*2965	3009
watts	100/38	2864	2975	3050
APPROXIMATE WATER CONSUMPTION PER 24 HR.	70/21	*841 (3.182)	742 (2.808)	632 (2.393)
	80/27	765 (2.897)	612 (2.316)	516 (1.955)
	90/32	742 (2.808)	*504 (1.906)	400 (1.513)
gal./day (m³/day)	100/38	729 (2.758)	479 (1.814)	304 (1.151)
FREEZING CYCLE TIME	70/21	*25	26	28
	80/27	26	27	29
	90/32	26	*28	30
min.	100/38	26	28	32
HARVEST CYCLE TIME	70/21	*5.5	4.8	4.3
	80/27	4.9	3.8	3.7
	90/32	4.8	*3.0	2.7
min.	100/38	4.9	2.9	2.5
HEAD PRESSURE	70/21	*225 (15.8)	235 (16.5)	256 (18.0)
	80/27	233 (16.4)	249 (17.5)	273 (19.2)
	90/32	235 (16.5)	*260 (18.3)	283 (19.9)
PSIG (kg/cm²G)	100/38	242 (17.0)	265 (18.7)	305 (21.4)
SUCTION PRESSURE	70/21	*38 (2.7)	39 (2.8)	41 (2.9)
	80/27	39 (2.8)	41 (2.9)	43 (3.1)
	90/32	39 (2.8)	*43 (3.0)	45 (3.2)
PSIG (kg/cm²G)	100/38	40 (2.8)	43 (3.1)	47 (3.3)

TOTAL HEAT OF REJECTION FROM CONDENSER 19250 BTU/h [AT 90°F (32°C) / WT 70°F (21°C)]

TOTAL HEAT OF REJECTION FROM COMPRESSOR 3225 BTU/h [AT 90°F (32°C) / WT 70°F (21°C)]

CONDENSER VOLUME 214 CU. IN (URC-20F)

Note: Pressure data is recorded first 5 minutes into freezing cycle. The data without * marks should be used for reference only.

We reserve the right to make changes in specifications and design without prior notice.

[c] KM-1600SWF3

APPROXIMATE ICE PRODUCTION PER 24 HR.	AMBIENT TEMP. (°F/°C)	WATER TEMP. (°F/°C)					
		50/10		70/21		90/32	
	70/21	1500	<u>680</u>	1495	<u>678</u>	1451	<u>658</u>
	80/27	1496	<u>679</u>	1489	<u>675</u>	1423	<u>646</u>
	90/32	1495	<u>678</u>	1484	<u>673</u>	1426	<u>647</u>
lbs./day <u>kg./day</u>	100/38	1473	<u>668</u>	1470	<u>667</u>	1373	<u>623</u>
APPROXIMATE ELECTRIC CONSUMPTION	70/21	2563		2573		2634	
	80/27	2570		2586		2673	
	90/32	2573		2597		2675	
	watts	2601		2615		2746	
APPROXIMATE WATER CONSUMPTION PER 24 HR.	70/21	1892	<u>7.16</u>	2034	<u>7.70</u>	2741	<u>10.38</u>
	80/27	2000	<u>7.57</u>	2221	<u>8.41</u>	3213	<u>12.16</u>
	90/32	2034	<u>7.70</u>	2377	<u>9.00</u>	3264	<u>12.35</u>
	gal./day <u>m³/day</u>	2348	<u>8.89</u>	2585	<u>9.79</u>	4078	<u>15.44</u>
FREEZING CYCLE TIME	70/21	24		25		26	
	80/27	24		25		26	
	90/32	25		26		27	
	min.	25		26		28	
HARVEST CYCLE TIME	70/21	5.0		4.3		3.8	
	80/27	4.4		3.3		3.2	
	90/32	4.3		2.5		2.2	
	min.	4.0		2.4		2.0	
HEAD PRESSURE	70/21	270	<u>19.0</u>	271	<u>19.1</u>	274	<u>19.3</u>
	80/27	271	<u>19.1</u>	273	<u>19.2</u>	276	<u>19.4</u>
	90/32	271	<u>19.1</u>	275	<u>19.3</u>	278	<u>19.5</u>
	PSIG <u>kg/cm²G</u>	272	<u>19.1</u>	276	<u>19.4</u>	280	<u>19.7</u>
SUCTION PRESSURE	70/21	40	<u>2.8</u>	41	<u>2.9</u>	43	<u>3.0</u>
	80/27	41	<u>2.9</u>	42	<u>3.0</u>	45	<u>3.2</u>
	90/32	41	<u>2.9</u>	43	<u>3.0</u>	46	<u>3.2</u>
	PSIG <u>kg/cm²G</u>	42	<u>2.9</u>	44	<u>3.1</u>	48	<u>3.4</u>

TOTAL HEAT OF REJECTION FROM CONDENSER 17560 BTU/h [AT 90°F (32°C) / WT 70°F (21°C)]

TOTAL HEAT OF REJECTION FROM COMPRESSOR 3100 BTU/h [AT 90°F (32°C) / WT 70°F (21°C)]

WATER FLOW FOR CONDENSER 155 gal. / h (AT 100°F (38°C) / WT 90°F (32°C))

PRESSURE DROP OF COOLING WATER LINE less than 10 PSIG

Note: Pressure data is recorded first 5 minutes into freezing cycle. The data NOT in bold should be used for reference only.

We reserve the right to make changes in specifications and design without prior notice.

[d] KM-1600SRF3

APPROXIMATE ICE PRODUCTION PER 24 HR.	Ambient Temp. (°F/°C)	Water Temp. (°F/°C)		
		50/10	70/21	90/32
lbs./day (kg/day)	70/21	*1461 (663)	1426 (647)	1365 (619)
	80/27	1434 (651)	1380 (626)	1311 (595)
	90/32	1426 (647)	*1341 (608)	1274 (578)
	100/38	1409 (639)	1325 (601)	1213 (550)
APPROXIMATE ELECTRIC CONSUMPTION	70/21	*2775	2812	2851
watts	80/27	2803	2860	2893
	90/32	2812	*2900	2936
	100/38	2816	2909	2970
APPROXIMATE WATER CONSUMPTION PER 24 HR.	70/21	*773 (2.925)	679 (2.569)	601 (2.274)
gal./day (m ³ /day)	80/27	701 (2.654)	555 (2.101)	505 (1.912)
	90/32	679 (2.569)	*452 (1.710)	388 (1.470)
	100/38	680 (2.575)	437 (1.654)	330 (1.249)
FREEZING CYCLE TIME	70/21	*25	26	27
min.	80/27	25	26	29
	90/32	26	*27	29
	100/38	26	27	31
HARVEST CYCLE TIME	70/21	*5.5	4.8	4.3
min.	80/27	4.9	3.8	3.7
	90/32	4.8	*3.0	2.7
	100/38	4.9	2.9	2.5
HEAD PRESSURE	70/21	*225 (15.8)	235 (16.5)	252 (17.7)
PSIG (kg/cm ² G)	80/27	233 (16.4)	249 (17.5)	267 (18.8)
SUCTION PRESSURE	90/32	235 (16.5)	*260 (18.3)	278 (19.6)
	100/38	240 (16.8)	264 (18.6)	295 (20.7)
	70/21	*37 (2.6)	38 (2.7)	41 (2.9)
	80/27	38 (2.6)	39 (2.7)	43 (3.0)
	90/32	38 (2.7)	*40 (2.8)	44 (3.1)
	100/38	39 (2.7)	41 (2.9)	47 (3.3)
TOTAL HEAT OF REJECTION FROM CONDENSER		22000 BTU/h [AT 90°F (32°C) / WT 70°F (21°C)]		
TOTAL HEAT OF REJECTION FROM COMPRESSOR		3450 BTU/h [AT 90°F (32°C) / WT 70°F (21°C)]		
CONDENSER VOLUME		214 CU. IN (URC-20F)		

Note: Pressure data is recorded first 5 minutes into freezing cycle. The data without * marks should be used for reference only.

We reserve the right to make changes in specifications and design without prior notice.

IV. SERVICE DIAGNOSIS

1. NO ICE PRODUCTION

PROBLEM	POSSIBLE CAUSE		REMEDY
[1] The icemaker will not start	a) Power Supply	1. "OFF" position.	1. Move to "ON" position.
		2. Loose connections.	2. Tighten.
		3. Bad contacts.	3. Check for continuity and replace.
		4. Voltage too high.	4. Check and get recommended voltage.
	b) Fuse (Inside Fused Disconnect, if any)	1. Blown out.	1. Check for short circuit and replace.
	c) Control Switch	1. "OFF" position.	1. Move to "ICE" position.
		2. Bad contacts.	2. Check for continuity and replace.
	d) Bin Control Thermostat	1. Tripped with bin filled with ice.	1. Remove ice.
		2. Ambient temperature too cool.	2. Increase ambient temperature.
		3. Set too warm.	3. See "II.2.[d] CONTROLS AND ADJUSTMENTS, 5) Bin Control."
		4. Bulb out of position.	4. Place in position.
		5. Bad contacts or leaks in bulb.	5. Check for continuity and replace.
	e) High Pressure Control	1. Bad contacts.	1. Check for continuity and replace.
	f) Transformer	1. Thermal fuse blown out or coil winding opened.	1. Replace.
	g) Wiring to Controller Board	1. Loose connections or open.	1. Check for continuity and replace.
	h) Thermistor	1. Leads short-circuit or open and High Temperature Safety operates.	1. See "II.2.[d] CONTROLS AND ADJUSTMENTS, 1) Defrost Control."
	i) Hot Gas Solenoid Valve	1. Continues to open in freeze cycle and High Temperature Safety operates.	1. Check for power off in freeze cycle and replace.
	j) Water Supply Line	1. Water supply off and water supply cycle does not finish.	1. Check and get recommended pressure.
		2. Condenser water pressure too low or off and Pressure Control opens and closes frequently to finally operate High Temperature Safety.	2. Check and get recommended pressure.
	k) Water Solenoid	1. Mesh filter or orifice gets clogged and water supply cycle does not finish.	1. Clean.
2. Coil winding opened.		2. Replace.	
3. Wiring to Water Valve.		3. Check for loose connection or open, and replace.	

PROBLEM	POSSIBLE CAUSE		REMEDY
	l) Controller Board	1. Defective	1. See "II.2[e] CHECKING CONTROLLER BOARD."
	m) Interlock Switch (Cleaning Valve)	1. OFF position.	1. Move to ON position.
		2. Bad contacts.	2. Check for continuity and replace.
[2] Water continues to be supplied, and the ice-maker will not start.	a) Float switch	1. Connector disconnected.	1. Place in position.
		2. Leads opened or defective switch.	2. Check and replace.
		3. Float does not move freely.	3. Clean or replace.
	b) Controller Board	1. Defective.	1. Replace.
[3] Compressor	a) Wash Switch	1. WASH position.	1. Move to ICE position.
		2. Bad contacts.	2. Check and replace.
	b) High Pressure Controller	1. Dirty Air Filter or Condenser.	1. Clean.
		2. Ambient or condenser water temp. too warm.	2. Reduce ambient temp.
		3. Refrigerant overcharged.	3. Recharge.
		4. Condenser water pressure too low or off. [Water-cooled model only].	4. Check and get recommended pressure.
		5. Fan not operating. [Except water-cooled model].	5. See chart 1 - [6].
		6. Refrigerant line or components plugged.	6. Clean and replace Drier.
	c) Water Regulator	1. Set too high.	1. Adjust lower.
	d) Overload Protector	1. Bad contacts.	1. Check for continuity and replace.
		2. Voltage too low.	2. Increase voltage.
		3. Refrigerant overcharged or undercharged.	3. Recharge.
		4. Line Valve continues to close in freeze cycle and Overload Protector operates.	4. Check Line Valve's operation in freeze cycle and replace.
	e) Starter	1. Bad contacts.	1. Check and replace.
		2. Coil winding opened.	2. Replace.
	f) Start Capacitor or Run Capacitor	1. Defective.	1. Replace.
	g) Magnetic Contactor	1. Bad contacts.	1. Check for continuity and replace.
		2. Coil winding opened.	2. Replace.
	h) Compressor	1. Wiring to Compressor.	1. Check for loose connection or open, and replace.
		2. Defective.	2. Replace.
		3. Protector tripped.	3. Reduce temperature.
	i) Controller board	1. Defective.	1. See "II.2. [e] CHECKING CONTROLLER BOARD."
[4] Water continues to be supplied in freeze cycle.	a) Water Solenoid Valve	1. Diaphragm does not close.	1. Check for water leaks with icemaker off.
	b) Controller Board	1. Defective.	1. See "II.2.[e] CHECKING CONTROLLER BOARD."

PROBLEM	POSSIBLE CAUSE		REMEDY
[5] No water comes from Spray Tubes. Water Pump will not start, or freeze cycle time is too short..	a) Water Supply Line	1. Water pressure too low and water level in Water Tank too low.	1. Check and get recommended pressure.
	b) Water Solenoid Valve	1. Dirty mesh filter or orifice and water level in Water Tank too low.	1. Clean.
	c) Water System	1. Water leaks.	1. Check connections for water leaks, and replace.
		2. Clogged.	2. Clean.
	d) Pump Motor	1. Motor winding opened.	1. Replace.
		2. Bearing worn out.	2. Replace.
		3. Wiring to Pump Motor.	3. Check for loose connection or open, and replace.
		4. Defective Capacitor.	4. Replace.
		5. Defective or bound impeller.	5. Replace and clean.
		6. Mechanical Seal worn out.	6. Check and replace.
e) Controller Board	1. Defective.	1. See "II.2. [e] CHECKING CONTROLLER BOARD."	
[6] Fan Motor will not start, or is not operating.	a) Fan Motor	1. Motor winding opened.	1. Replace.
		2. Bearing worn out.	2. Replace.
		3. Wiring to Fan Motor.	3. Check for loose connection or open, and replace.
		4. Defective Capacitor.	4. Replace
		5. Fan blade bound.	5. Check and replace.
	b) Controller Board	1. Defective.	1. See "II.2. [e] CHECKING CONTROLLER BOARD."
[7] All components run but no ice is produced.	a) Refrigerant	1. Undercharged.	1. Check for leaks and recharge.
		2. Air or moisture trapped.	2. Replace Drier, and recharge.
	b) Compressor	1. Defective valve.	1. Replace.
	c) Hot Gas Solenoid Valve	1. Continues to open in freeze cycle.	1. Check and replace.
	d) Line Valve	1. Continues to close in freeze cycle.	1. Check and replace
	e) Water Supply Line [Water-cooled model only]	1. Condenser water pressure too low or off and Pressure Control opens and closes frequently.	1. Check and get recommended pressure.

2. EVAPORATOR IS FROZEN UP

PROBLEM	POSSIBLE CAUSE		REMEDY
[1] Freeze cycle time is too long.	a) Float Switch	1. Leads short-circuit or defective switch.	1. Check and replace.
		2. Float does not move freely.	2. Clean or replace.
	b) Water Solenoid Valve	1. Diaphragm does not close.	1. Check for water leaks with icemaker off.
	c) Controller Board	1. Defective.	1. See "II.2[e] CHECKING CONTROLLER BOARD."
[2] All ice formed on Evaporator does not fall into bin in harvest cycle.	a) Evaporator	1. Scaled up.	1. Clean.
	b) Water Supply Line	1. Water pressure too low.	1. Check and get recommended pressure.
	c) Water Solenoid Valve	1. Dirty mesh filter or orifice.	1. Clean.
		2. Diaphragm does not close.	2. Check for water leaks with icemaker off.
	d) Ambient and/or water temperature	1. Too cool.	1. Increase temperature.
	e) Line Valve	1. Continues to open in harvest cycle.	1. Check operation in harvest cycle and replace.
	f) Thermistor	1. Out of position or loose attachment.	1. See "V. 11. REMOVAL AND REPLACEMENT OF THERMISTOR."
g) Controller Board	1. Defrost Timer is set too short.	1. Adjust longer, referring to "II. 2. [d] CONTROLS AND ADJUSTMENT, 2) Defrost Timer."	
	2. Defective.	2. See "II. 2.[e] CHECKING CONTROLLER BOARD."	
[3] Others	a) Spray Tubes	1. Clogged.	1. Clean.
		2. Out of position.	2. Place in position.
	b) Water System	1. Dirty.	1. Clean.
	c) Refrigerant	1. Undercharged.	1. Check for leaks and recharge.
	d) Expansion Valve	1. Bulb out of position or loose attachment.	1. Place in position.
		2. Defective.	2. Replace.
	e) Hot Gas Solenoid Valve	1. Coil winding opened.	1. Replace.
2. Plunger does not move.		2. Replace.	
3. Wiring to Hot Gas Valve.		3. Check for loose connection or open, and replace.	

3. LOW ICE PRODUCTION

PROBLEM	POSSIBLE CAUSE	REMEDY
[1] Freeze cycle time is long.	a) See chart 1 - [3], and check dirty Air Filter or Condenser, ambient or water temperature, water pressure, Water Regulator or refrigerant charge.	
	b) See chart 2 - [1], and check Float Switch, Water Solenoid Valve or Controller Board.	
[2] Harvest cycle time is long	a) See chart 2 - [2], and check Controller Board, Thermistor, Evaporator, ambient and/or water temperature, water supply line, Water Solenoid Valve, Line Valve, or Gas Valve.	

4. ABNORMAL ICE

PROBLEM	POSSIBLE CAUSE		REMEDY
[1] Small Cube	a) Ice Cube Guide	1. Out of position. Circulated water falls into bin.	1. Place in position.
	b) See chart 1 - [5], and check water supply line, Water Solenoid Valve, water system, Pump Motor or Controller Board.		
	c) Drain Valve	1. Dirty.	1. Clean.
[2] Cloudy or irregular cube	a) See chart 2 - [1] and - [3], and check Float Switch, Water Solenoid Valve, Controller Board, Spray Tubes, water system, refrigerant charge or Expansion Valve.		
	b) Spray Guide	1. Dirty.	1. Clean.
	c) Water Quality	1. High hardness or contains impurities.	1. Install a water filter or softener.

5. OTHERS

PROBLEM	POSSIBLE CAUSE		REMEDY
[1] Icemaker will not stop when bin is filled with ice.	a) Bin Control Thermostat	1. Set too cold.	1. Adjust warmer.
		2. Defective.	2. Replace.
[2] Abnormal noise	a) Pump Motor	1. Bearings worn out.	1. Replace.
	b) Fan Motor	1. Bearings worn out.	1. Replace.
		2. Fan blade deformed.	2. Replace fan blade.
		3. Fan blade does not move freely.	3. Replace.
	c) Compressor	1. Bearings worn out, or cylinder valve broken.	1. Replace.
		2. Mounting pad out of position.	2. Reinstall
d) Refrigerant Lines	1. Rub or touch lines or other surfaces.	1. Replace.	
[3] Ice in storage bin often melts.	a) Bin Drain	1. Plugged.	1. Clean.

V. REMOVAL AND REPLACEMENT OF COMPONENTS

IMPORTANT

Ensure all components, fasteners and thumbscrews are securely in place after the equipment is serviced.

IMPORTANT

1. The Polyol Ester (POE) oils used in R-404A units can absorb moisture quickly. Therefore it is important to prevent moisture from entering the system when replacing or servicing parts.
2. Always install a new filter drier every time the sealed refrigeration system is opened.
3. Do not leave the system open for longer than 5 minutes when replacing or servicing parts.

1. SERVICE FOR REFRIGERANT LINES

[a] REFRIGERANT RECOVERY

The icemaker unit is provided with two Refrigerant Access Valves—one on the low-side and one on the high-side line. Using proper refrigerant practices recover the refrigerant from the Access Valves and store it in an approved container. Do not discharge the refrigerant into the atmosphere.

[b] EVACUATION AND RECHARGE [R-404A]

- 1) Attach Charging Hoses, a Service Manifold and a Vacuum Pump to the system. Be sure to connect charging hoses to both High and Low -side Access Valves.

IMPORTANT

The vacuum level and Vacuum Pump may be the same as those for current refrigerants. However, the rubber hose and gauge manifold to be used for evacuation and refrigerant charge should be exclusively for POE oils.

- 2) Turn on the Vacuum Pump. Never allow the oil in the Vacuum Pump to flow backward.
- 3) Allow the Vacuum Pump to pull down to a 29.9" Hg vacuum. Evacuating period depends on pump capacity.

- 4) Close the Low-side Valve and High-side Valve on the Service Manifold.
- 5) Disconnect the Vacuum Pump, and attach a Refrigerant Service Cylinder to the High-side line. Remember to loosen the connection, and purge the air from the Hose. For water-cooled models, see the Nameplate for the required refrigerant charge. For remote air-cooled models, see the Charge Label in the machine compartment. Hoshizaki recommends only virgin refrigerant or reclaimed refrigerant which meets ARI Standard No. 700-88 be used.
- 6) A liquid charge is recommended for charging an R-404A system. Invert the service cylinder. Open the High-side, Service Manifold Valve.
- 7) Allow the system to charge with liquid until the pressures balance.
- 8) If necessary, add any remaining charge to the system through the Low-side. Use a throttling valve or liquid dispensing device to add the remaining liquid charge through the Low-side access port with the unit running.
- 9) Close the two Refrigerant Access Valves, and disconnect the Hoses and Service Manifold.
- 10) Cap the Access Valves to prevent a possible leak.

2. BRAZING

DANGER

1. Refrigerant R-404A itself is not flammable at atmospheric pressure and temperatures up to 176° F.
2. Refrigerant R-404A itself is not explosive or poisonous. However, when exposed to high temperatures (open flames) R-404A can be decomposed to form hydrofluoric acid and carbonyl fluoride both of which are hazardous.
3. Always recover the refrigerant and store it in an approved container. Do not discharge the refrigerant into the atmosphere.
4. Do not use silver alloy or copper alloy containing Arsenic.
5. Do not use R-404A as a mixture with pressurized air for leak testing. Refrigerant leaks can be detected by charging the unit with a little refrigerant, raising the pressure with nitrogen and using an electronic leak detector.

Note: All brazing-connections inside the Evaporator Case are clear-paint coated. Sandpaper the brazing connections before unbrazing the components. Use a good abrasive cloth to remove coating.

3. REMOVAL AND REPLACEMENT OF COMPRESSOR

IMPORTANT

Always install a new Drier every time the sealed refrigeration system is opened. Do not replace the Drier until after all other repair or replacement has been made.

Note: When replacing a Compressor with a defective winding, be sure to install the new Start Capacitor and Start Relay supplied with the replacement Compressor. Due to the ability of the POE oil in the compressor to absorb moisture quickly, the Compressor must not be opened more than 15 minutes for replacement or service. Do not mix lubricants of different compressors even if both are charged with R-404A, except when they use the same lubricant.

- 1) Turn off the power supply.
- 2) Remove the panels.
- 3) Recover the refrigerant and store it in an approved container.
- 4) Remove the Terminal Cover on the Compressor, and disconnect the Compressor Wiring.
- 5) Remove the Discharge and Suction Pipes using brazing equipment.
- 6) Remove the Hold-down Bolts, Washers and Rubber Grommets.
- 7) Slide and remove the Compressor. Unpack the new Compressor package. Install the new Compressor.
- 8) Attach the Rubber Grommets of the prior Compressor.
- 9) Sandpaper the Suction, Discharge and Process Pipes.
- 10) Place the Compressor in position, and secure it using the Bolts and Washers.
- 11) Remove plugs from the Suction, Discharge and Process Pipes.
- 12) Braze the Process, Suction and Discharge lines (Do not change this order), while purging with nitrogen gas flowing at the pressure 3-4 PSIG.
- 13) Install the new Filter Drier.

- 14) Check for leaks using nitrogen gas (140 PSIG) and soap bubbles.
- 15) Evacuate the system, and charge it with refrigerant. For water-cooled models, see the Nameplate for the required refrigerant charge. For remote air-cooled models, see the Charge Label in the machine compartment.
- 16) Connect the Terminals, and replace the Terminal Cover in its correct position.
- 17) Replace the panels in their correct positions.
- 18) Turn on the power supply.

4. REMOVAL AND REPLACEMENT OF DRIER

IMPORTANT

Always install a new Drier every time the sealed refrigeration system is opened. Do not replace the Drier until after all other repair or replacement has been made.

- 1) Turn off the power supply.
- 2) Remove the panels.
- 3) Recover the refrigerant and store it in an approved container.
- 4) Remove the Drier.
- 5) Install the new Drier, with the arrow on the Drier, in the direction of the refrigerant flow. Use nitrogen gas at the pressure of 3-4 PSIG when brazing the tubings.
- 6) Check for leaks using nitrogen gas (140 PSIG) and soap bubbles.
- 7) Evacuate the system, and charge it with refrigerant. For water-cooled models, see the Nameplate for the required refrigerant charge. For remote air-cooled models, see the Charge Label in the machine compartment.
- 8) Replace the panels in their correct positions.
- 9) Turn on the power supply.

5. REMOVAL AND REPLACEMENT OF EXPANSION VALVE

IMPORTANT

Sometimes moisture in the refrigerant circuit exceeds the Drier capacity and freezes up at the Expansion Valve. Always install a new Drier every time the sealed refrigeration system is opened. Do not replace the Drier until after all other repair or replacement has been made.

- 1) Turn off the power supply.
- 2) Remove the panels.
- 3) Recover the refrigerant and store it in an approved container.
- 4) Remove the insulation and the Expansion Valve Bulb on the suction line.
- 5) Remove the Expansion Valve Cover, and disconnect the Expansion Valve using brazing equipment.
- 6) Braze the new Expansion Valve, with nitrogen gas flowing at the pressure of 3-4 PSIG.

WARNING

1. Do not heat the wall. Place a steel barrier for protection.
2. Always protect the valve body by using a damp cloth to prevent the valve from overheating. Do not braze with the valve body exceeding 250°F.

- 7) Install the new Drier.
- 8) Check for leaks using nitrogen gas (140 PSIG) and soap bubbles.
- 9) Evacuate the system, and charge it with refrigerant. For water-cooled models, see the Nameplate for the required refrigerant charge. For remote air-cooled models, see the Charge Label in the machine compartment.
- 10) Attach the Bulb to the suction line in position. Be sure to secure it with clamps and to insulate it.
- 11) Place the new set of Expansion Valve Covers in position.
- 12) Replace the panels in their correct positions.
- 13) Turn on the power supply.

6. REMOVAL AND REPLACEMENT OF HOT GAS VALVE, LINE VALVE AND GAS VALVE

CAUTION

Always use a copper tube of the same diameter and length when replacing the hot gas lines; otherwise the performance may be reduced.

IMPORTANT

Always install a new Drier every time the sealed refrigeration system is opened.
Do not replace the Drier until after all other repair or replacement has been made.

- 1) Turn off the power supply.
- 2) Remove the panels.
- 3) Recover the refrigerant and store it in an approved container.
- 4) Remove the screw and the Solenoid.
- 5) Disconnect the Hot Gas Valve or Line Valve using brazing equipment.
- 6) Install the new valve.

WARNING

Always protect the valve body by using a damp cloth to prevent the valve from overheating. Do not braze with the valve body exceeding 250°F.

- 7) Install the new Drier.
- 8) Check for leaks using nitrogen gas (140 PSIG) and soap bubbles.
- 9) Evacuate the system, and charge it with refrigerant. For water-cooled models, see the Name plate for the required refrigerant charge. For remote air-cooled models, see the Charge Label in the machine compartment.
- 10) Cut the leads of the Solenoid allowing enough lead length to reconnect using closed end connectors.

- 11) Connect the new Solenoid leads.
- 12) Attach the Solenoid to the valve body, and secure it with a screw.
- 13) Replace the panels in their correct positions.
- 14) Turn on the power supply.

7. REMOVAL AND REPLACEMENT OF EVAPORATOR

IMPORTANT

Always install a new Drier every time the sealed refrigeration system is opened.
Do not replace the Drier until after all other repairs or replacement have been made.

- 1) Turn off the power supply.
- 2) Remove the panels and the Top Insulation over the Evaporator.
- 3) Recover the refrigerant and store it in an approved container.
- 4) Remove the Spray Tubes and the Insulations at the “U” shaped notch where the refrigeration tubings pass through the molded chassis.
- 5) Remove the Insulation Tube, and disconnect the Evaporator Inlet Tubing at the Tee next to the Expansion Valve.
- 6) Lift up the Evaporator, and disconnect the Evaporator Outlet Tubing.
- 7) Install the new Evaporator.
- 8) Install the new Drier.
- 9) Check for leaks using nitrogen gas (140 PSIG) and soap bubbles.
- 10) Evacuate the system, and charge it with refrigerant. For water-cooled models, see the Nameplate for the required refrigerant charge. For remote air-cooled models, see the Charge Label in the machine compartment.
- 11) Replace the removed parts in the reverse order of which they were removed.
- 12) Replace the Top Insulation and the panels in their correct positions.
- 13) Turn on the power supply.

8. REMOVAL AND REPLACEMENT OF WATER REGULATING VALVE - WATER-COOLED MODEL ONLY

IMPORTANT

Always install a new Drier every time the sealed refrigeration system is opened.
Do not replace the Drier until after all other repair or replacement has been made.

- 1) Turn off the power supply.
- 2) Close the Water Supply Line Shut-off Valve.
- 3) Remove the panels.
- 4) Recover the refrigerant and store it in an approved container.
- 5) Disconnect the Capillary Tube at the Condenser outlet using brazing equipment.
- 6) Disconnect the Flare-connections of the valve.
- 7) Remove the screws and the valve from the Bracket.
- 8) Install the new valve, and braze the Capillary Tube.
- 9) Install the new Drier.
- 10) Check for leaks using nitrogen gas (140 PSIG) and soap bubbles.
- 11) Evacuate the system, and charge it with refrigerant. See the Nameplate for the required refrigerant charge.
- 12) Connect the Flare-connections.
- 13) Open the Water Supply Line Shut-off Valve.
- 14) Check for water leaks.
- 15) Replace the panels in their correct positions.
- 16) Turn on the power supply.

9. ADJUSTMENT OF WATER REGULATING VALVE - WATER-COOLED MODEL ONLY

The Water Regulating Valve (also called “WATER REGULATOR”) is factory-adjusted. No adjustment is required under normal use. Adjust the Water Regulator, if necessary, using the following procedures.

- 1) Attach a pressure gauge to the high-side line of the system. Or prepare a thermometer to check for the condenser drain temperature.
- 2) Rotate the adjustment screw by using a flat blade screwdriver, so that the pressure gauge shows 270 PSIG or the thermometer reads 104–115°F, 5 minutes after a freeze cycle or icemaking process starts. When the pressure exceeds 270 PSIG, or the condenser drain temperature exceeds 115°F, rotate the adjustment screw counterclockwise. See Fig. 1.
- 3) Check that the pressure or the condenser drain temperature holds a stable setting.

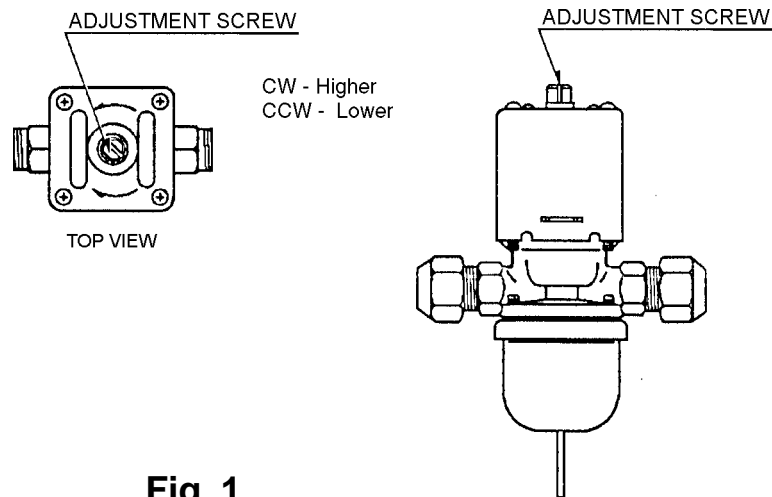

Fig. 1

10. REMOVAL AND REPLACEMENT OF CONDENSING PRESSURE REGULATOR (C.P.R.) - REMOTE AIR-COOLED MODEL ONLY

IMPORTANT

Always install a new Drier every time the sealed refrigeration system is opened. Do not replace the Drier until after all other repair or replacement has been made.

- 1) Turn off the power supply.
- 2) Remove the panels from the remote condenser unit.
- 3) Recover the refrigerant and store it in an approved container.
- 4) Before heating, break off the stub on the dome to release the dome charge.
- 5) Disconnect the C.P.R. using brazing equipment.
- 6) Install the new C.P.R. Use nitrogen gas at the pressure of 3-4 PSIG when brazing the C.P.R.

WARNING

Always protect the C.P.R. body by using a damp cloth to prevent the C.P.R. from overheating. Do not braze with the C.P.R. body exceeding 250°F.

- 7) Install the new Drier in the icemaker.
- 8) Check for leaks using nitrogen gas (140 PSIG) and soap bubbles.
- 9) Evacuate the system and charge it with refrigerant. See the Charge Label in the machine compartment in the icemaker.
- 10) Replace the panels in their correct positions.
- 11) Turn on the power supply.

11. REMOVAL AND REPLACEMENT OF THERMISTOR

CAUTION

1. Fragile, handle very carefully.
2. Always use a recommended sealant (High Thermal Conductive Type), Model KE4560RTV manufactured by SHINETSU SILICONE, Part Code 60Y000-11, or Part Code 4A0683-01 equivalent.
3. Always use a recommended foam insulation (Non-absorbent Type) or equivalent.

- 1) Turn off the power supply.
- 2) Remove the panels.
- 3) Remove the Control Box Cover.
- 4) Disconnect the Thermistor leads from the K3 Connector on the Controller Board.
- 5) Remove the Plastic Cable Ties, Foam Insulation, Thermistor Holder and Thermistor. See Fig. 2.

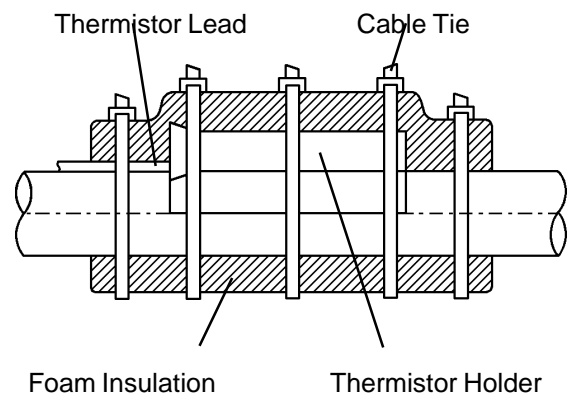

Fig. 2

- 6) Scrape away the old sealant on the Thermistor Holder and the Suction Pipe.
- 7) Wipe off moisture or condensation on the Suction Pipe.
- 8) Smoothly apply recommended sealant (KE4560RTV, Part Code 60Y000-11 or 4A0683-01) to the Thermistor Holder concave.
- 9) Attach the new Thermistor to the Suction Pipe very carefully to prevent damage to the leads. And secure it using the Thermistor Holder and recommended foam insulation.
- 10) Secure the insulation using the Plastic Cable Ties.
- 11) Connect the Thermistor leads through the bushing of the Control Box to the K3 Connector on the Controller Board.

Note: Do not cut the leads of the Thermistor while installing it.

- 12) Replace the Control Box Cover and the panels in their correct positions.
- 13) Turn on the power supply.

12. REMOVAL AND REPLACEMENT OF FAN MOTOR

Note: When replacing a Fan Motor with defective winding, it is recommended that a new capacitor be installed.

- 1) Turn off the power supply.
- 2) Remove the panels.
- 3) Remove the Junction Box Cover from the remote condenser unit (Remote Air-cooled model).
- 4) Remove the closed end connectors from the Fan Motor leads.
- 5) Remove the Fan Motor Bracket and Fan Motor.
- 6) Install the new Fan Motor, and replace the removed parts in the reverse order of which they were removed.
- 7) Replace the panels in their correct positions.
- 8) Replace the Junction Box Cover in its correct position (Remote Air-cooled model).
- 9) Turn on the power supply.

13. REMOVAL AND REPLACEMENT OF WATER VALVE

- 1) Turn off the power supply.
- 2) Close the Water Supply Line Shut-off Valve.
- 3) Remove the Front Panel.
- 4) Remove the Valve Outlet Tubing by releasing the Clamp.
- 5) Remove the Bracket from the unit.
- 6) Remove the Fitting Nut and Water Valve.
- 7) Disconnect the Terminals from the Water Valve.

- 8) Install the new Water Valve, and replace the removed parts in the reverse order of which they were removed.
- 9) Open the Water Supply Line Shut-off Valve.
- 10) Turn on the power supply.
- 11) Check for leaks.
- 12) Replace the Front Panel in its correct position.

14. REMOVAL AND REPLACEMENT OF PUMP MOTOR

- 1) Turn off the power supply.
- 2) Remove the Front Panel.
- 3) Drain the Water Tank by removing the Insulation Panel and the cap at the front of the ice dropping hole. See Fig. 3.
- 4) Replace the removed parts in their correct positions.
- 5) Disconnect the Pump Suction and Discharge Hoses.
- 6) Remove the screws and the Pump Motor Bracket.
- 7) Remove the closed end connectors from the Pump Motor leads.
- 8) Remove the two screws and the Pump Motor Bracket.
- 9) Remove the Pump Housing, and check the Impeller.
- 10) If the Impeller is defective, install a new Impeller.
- 11) Install the new motor or new parts, and replace the removed parts in the reverse order of which they were removed.
- 12) Turn on the power supply, and check for leaks.
- 13) Replace the Front Panel in its correct position.

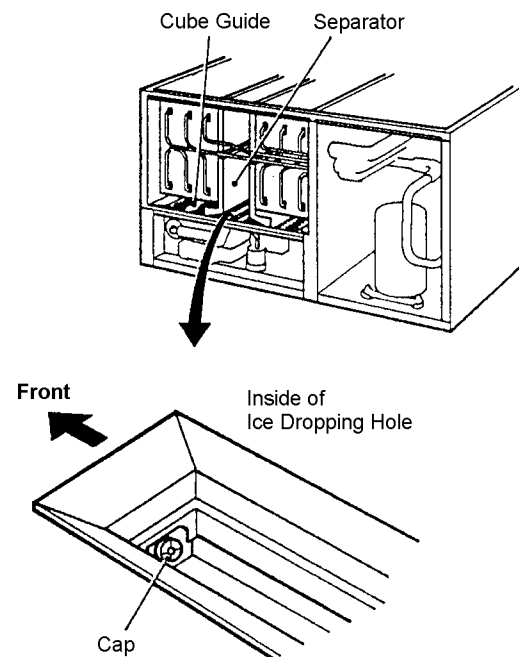

Fig. 3

15. REMOVAL AND REPLACEMENT OF SPRAY TUBES

- 1) Turn off the power supply.
- 2) Remove the Front Panel and the Insulation Panel.
- 3) Remove the Rubber Hoses from the Spray Tubes (Water Supply Pipe).
- 4) Release the Clamps, and disconnect the Rubber Hoses.
- 5) Remove the Spray Tubes by squeezing the side tabs.
- 6) Install the new Spray Tubes, and replace the removed parts in the reverse order of which they were removed.
- 7) Replace the panels in their correct positions.
- 8) Turn on the power supply.

VI. CLEANING AND MAINTENANCE INSTRUCTIONS

1. PREPARING THE ICEMAKER FOR LONG STORAGE

IMPORTANT

Ensure all components, fasteners and thumbscrews are securely in place after any maintenance or cleaning is done to the equipment.

WARNING

When shutting off the icemaker for an extended time, drain out all water from the water tank and remove the ice from the Storage Bin. The Storage Bin should be cleaned and dried. Drain the icemaker to prevent damage to the water supply line at subfreezing temperatures, using air or carbon dioxide. Shut off the icemaker until the proper ambient temperature is resumed.

- When the icemaker is not used for two or three days, it is sufficient to only move the Control Switch to the “OFF” position, unless the icemaker will be at subfreezing temperatures.

[1] On water-cooled model only, first remove the water from the water-cooled condenser:

- 1) Remove the Front Panel.
- 2) Move the Control Switch, on the Control Box, to the “OFF” position.
- 3) Wait 3 minutes.
- 4) Move the Control Switch to the “ICE” position.
- 5) Allow 5 minutes for the icemaker to fill with water and the Water Pump to start operating.
- 6) Close the Water-cooled Condenser Water Supply Line Shut-off Valve.
- 7) Open the Drain Valve for the water-cooled condenser water supply line.
- 8) Allow the line to drain by gravity.
- 9) Attach compressed air or carbon dioxide supply to the Condenser Water Line Drain Valve.
- 10) Quickly blow the water-cooled condenser out using compressed air or carbon dioxide until water stops coming out.

[2] Remove the water from the potable water supply line:

- 1) Remove the Front Panel. (Except water-cooled model)
- 2) Move the Control Switch, on the Control Box, to the "OFF" position.
- 3) Wait 3 minutes.
- 4) Close the Potable Water Supply Line Shut-off Valve and open the Potable Water Supply Line Drain Valve.
- 5) Allow the line to drain by gravity.
- 6) Attach compressed air or carbon dioxide supply to the Potable Water Line Drain Valve.
- 7) Move the Control Switch to the "ICE" position.
- 8) Blow the potable water line out using compressed air or carbon dioxide.

[3] Drain the Potable Water Tank:

- 1) Turn off the power supply.
- 2) Move the Control Switch to the "OFF" position.
- 3) Drain the Water Tank by removing the Insulation Panel and the Cap located on the front bottom part of the Ice Dropping Hole. See Fig. 3.
- 4) Replace the removed parts in their correct positions.
- 5) Remove all ice from the Storage Bin, and clean the Storage Bin.
- 6) Replace the Front Panel in its correct position.
- 7) Close the Drain Valve.

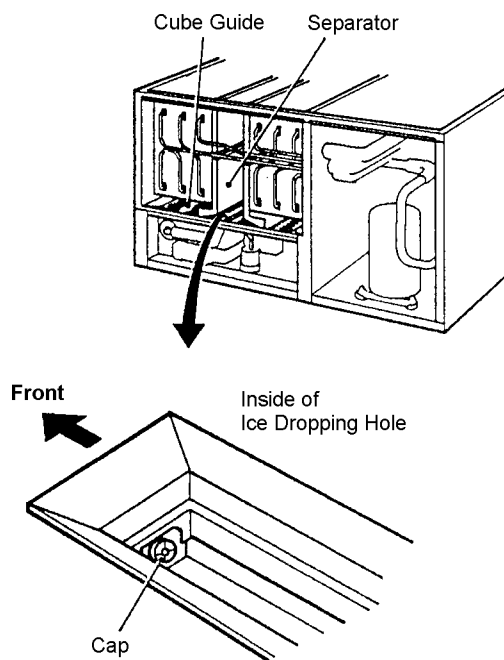

Fig. 3

2. CLEANING PROCEDURE

IMPORTANT

Ensure all components, fasteners and thumbscrews are securely in place after any maintenance or cleaning is done to the equipment.

WARNING

1. HOSHIZAKI recommends cleaning this unit at least once a year. More frequent cleaning, however, may be required in some existing water conditions.
2. To prevent injury to individuals and damage to the icemaker, do not use ammonia type cleaners.
3. Always wear liquid-proof gloves for safe handling of the cleaning and sanitizing solution. This will prevent irritation in case the solution comes into contact with skin.

IMPORTANT

1. The Cleaning Valve is used to allow solution flow to the inside of the Evaporator during the cleaning and sanitizing operation. It should be closed for all icemaking operation. The Compressor will not operate unless this valve is completely closed.
2. To open the Cleaning Valve, the Valve Handle should be parallel to the valve body. To close the valve, the Valve Handle should be at a right angle to the valve body.

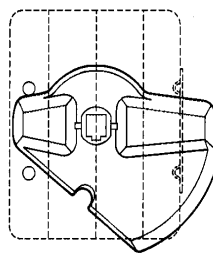

CLOSED POSITION

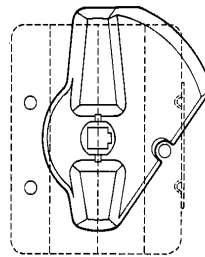

OPEN POSITION

[a] CLEANING PROCEDURE

- 1) Dilute 38 fl. oz. of the recommended cleaner Hoshizaki “Scale Away” or “LIME-A-WAY” (Economics Laboratory, Inc.) with 7 gal. of water.
- 2) Remove all ice from the Evaporator and the Storage Bin.

Note: To remove cubes on the Evaporator, turn off the power supply and turn it on after 3 minutes. The defrost cycle starts and the cubes will be removed from the Evaporator.

- 3) Turn off the power supply.
- 4) Remove the Front Panel and then remove the Insulation Panel, by first removing the thumbscrew, lifting the panel slightly and pulling it toward you.
- 5) Drain the Water Tank by removing the Cap located on the front bottom part of the Ice Dropping Hole. See Fig. 3.
- 6) Replace the cap in its correct position.
- 7) Pour the cleaning solution into the Water Tank.
- 8) Fully open the Cleaning Valve on the left side wall of the machine compartment.
- 9) Move the Control Switch, on the Control Box, to the “WASH” position.
- 10) Replace the Insulation Panel and the Front Panel in their correct positions.
- 11) Turn on the power supply, and start the washing process.
- 12) Turn off the power supply after 30 minutes.
- 13) Remove the Front Panel and the Insulation Panel.
- 14) Drain the Water Tank. (See the above step 5).
- 15) Replace the cap and the Insulation Panel in their correct positions.
- 16) Move the Control Switch to the “ICE” position.
- 17) Close the Cleaning Valve.

Note: The icemaker will not operate unless the Cleaning Valve is completely closed.

- 18) Replace the Front Panel in its correct position.

- 19) Turn on the power supply to fill the Water Tank with water.
- 20) Turn off the power supply after 3 minutes.
- 21) Remove the Front Panel, and fully open the Cleaning Valve.
- 22) Move the Control Switch to the "Wash" position.
- 23) Replace the Front Panel in its correct position.
- 24) Turn on the power supply to rinse off the cleaning solution.
- 25) Turn off the power supply after 5 minutes.
- 26) Remove the Front Panel and Insulation Panel.
- 27) Remove the Cap located on the front bottom part of the Ice Dropping Hole. Drain the Water Tank. Replace the Cap and the Insulation Panel in their correct positions.

Note: Do not replace the Insulation Panel when you proceed to "[b] SANITIZING PROCEDURE."

- 28) Repeat the above steps 16) through 27) three more times to rinse thoroughly.

Note: If you do not sanitize the icemaker, go to step 9) in "[b] SANITIZING PROCEDURE."

[b] SANITIZING PROCEDURE - Following Cleaning Procedure

- 1) Dilute a 5.25% Sodium Hypochlorite solution (chlorine bleach) with water (Add 2.5 fl. oz. of sanitizer to 5 gal. of water).
- 2) Remove the Insulation Panel, if it is in place.
- 3) Pour the sanitizing solution into the Water Tank.
- 4) Replace the Insulation Panel and the Front Panel in their correct position.

Note: Make sure that the Control Switch is in the "WASH" position and the Cleaning Valve is open.

- 5) Turn on the power supply, and start the sanitizing process.
- 6) Turn off the power supply after 15 minutes.
- 7) Remove the Front Panel and if necessary, the Insulation Panel.

- 8) Drain the Water Tank. See the above step 5) in “[a] CLEANING PROCEDURE.”
- 9) Replace the removed parts and the Insulation Panel in their correct position.
- 10) Repeat the above steps 16) through 28) in “[a] CLEANING PROCEDURE” two times to rinse thoroughly.
- 11) Close the Cleaning Valve.
- 12) Move the Control Switch to the “ICE” position.
- 13) Replace the Front Panel in its correct position.
- 14) Clean the Storage Bin with water.
- 15) Turn on the power supply, and start the automatic icemaking process.

3. MAINTENANCE

IMPORTANT

This icemaker must be maintained individually, referring to the instruction manual and labels provided with the icemaker.

1) Stainless Steel Exterior

To prevent corrosion, wipe the exterior occasionally with a clean and soft cloth. Use a damp cloth containing a neutral cleaner to wipe off oil or dirt build up.

2) Storage Bin and Scoop

- Wash your hands before removing ice. Use the plastic scoop provided.
- The Storage Bin is for ice use only. Do not store anything else in the bin.
- Keep the scoop clean. Clean it by using a neutral cleaner and rinse thoroughly.
- Clean the bin liner by using a neutral cleaner. Rinse thoroughly after cleaning.

3) Condenser (Except water-cooled model)

Check the Condenser once a year, and clean if required by using a brush or vacuum cleaner. More frequent cleaning may be required depending on the location of the icemaker.