NO. 71066

ISSUED: JAN. 19, 1992

REVISED: JULY 31, 2000



HOSHIZAKI
STACKABLE CRESCENT CUBER
MODEL
KM-2400SRB3

(FINAL) PARTS LIST

B-1 Nov., 1991
B-2 May, 1992
C-0 Jan., 1993
C-1 July, 1993
D-0 Dec., 1993
E-0 Jan., 1995
E-1 May, 1995
F-0 Jan., 1996
G-0 Jan., 1997
G-1 Sept., 1997
H-1 Jan., 1998
H-2 June, 1998
H-3 Nov., 1998
J-1 Jan., 1999

HA

MATERIAL ABBREVIATIONS

ALUMINUM

AL = Aluminum

COPPER

CU = Copper

PLASTIC

ABS = Acrylonitrile -butadiene - styrene
 AC = Polyacetal
 EVA = Ethylene vinyl acetate
 PA = Polyamide = Nylon
 PC = Polycarbonate
 PE = Polyethylene
 PES = Polyester
 PETP = Polyethylene terephthalate = Tetlon
 PP = Polypropylene
 PS = Polystyrene
 PTFE = Polytetrafluoroethylene = Teflon
 PUR = Polyurethane
 PVC = Polyvinyl chloride

RUBBER

VN = Vinyl Nitrile
 EPDM = EP rubber
 NBR = Nitrile butadiene rubber
 NR = Natural rubber
 NP = Neoprene
 SI.R = Silicone rubber
 SY.R = Synthetic rubber
 EPH = Epichlorohydrin

STEEL

GS = Galvanized steel
 SS = Stainless steel
 PS = Plated steel
 PAS = Primed steel

AUXILIARY CODE

Ex.1

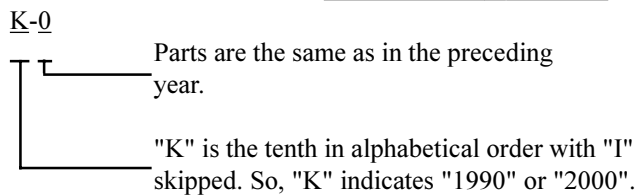

(Note) - = Part deleted.

x = Part deleted and replaced by "o" part.

o = New part for "x" in the same auxiliary code.

Ex.2

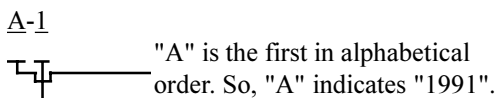

Ex.3

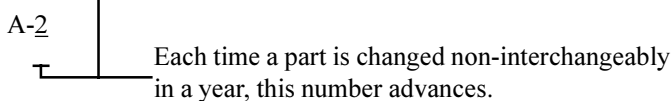

FASTENER ABBREVIATION LIST

ST	Phillips Truss Machine Screw
SP	Phillips Pan Head Machine Screw
SF	Phillips Flat Head Machine Screw
SS	Phillips Pan Head Machine Screw with Split Lock Washer
SW	Phillips Pan Head Machine Screw with Split Lock Washer and Flat Washer
T1	Phillips Truss Head Tapping Screw (Correspond to Type A)
T2	Phillips Truss Head Tapping Screw (Correspond to Type B)
T3	Phillips Truss Head Tapping Screw (Correspond to Type C)
FT	Phillips Truss Head Tapping Screw (Special)
BH	Hexagon Head Bolt
BC	Socket Head Cap Screw
BS	Hexagon Bolt with Split Washer
BW	Hexagon Bolt with Split Washer and Flat Washer
BF	Hexagon Flange Bolt
BR	Cross-Recessed Hexagon Head Bolt
BRW	Cross-Recessed Hexagon Head Bolt with Split Lock Washer and Flat Washer
WL	Split Lock Washer
WT	External Tooth Washer
WF	Flat Washer
WS	Spring Washer
NH	Hexagon Nut
NF	Hexagon Flange Nut
NC	Hexagon Cap Nut
NS	Square Nut
NW	Wing Nut

Ex. ST0308S (Phillips Truss Head Machine Screw
3x8, made of stainless steel)

Material	None:	Plated Steel
Length (mm)	S:	Stainless Steel
Nominal Diameter (mm)	B:	Brass
Form of Head	P:	Plastic
Description		

(Note) Second character is numerical except toe list.

Ex. S1, S2, B3 etc.

And abbreviations and names are shown under the illustration.

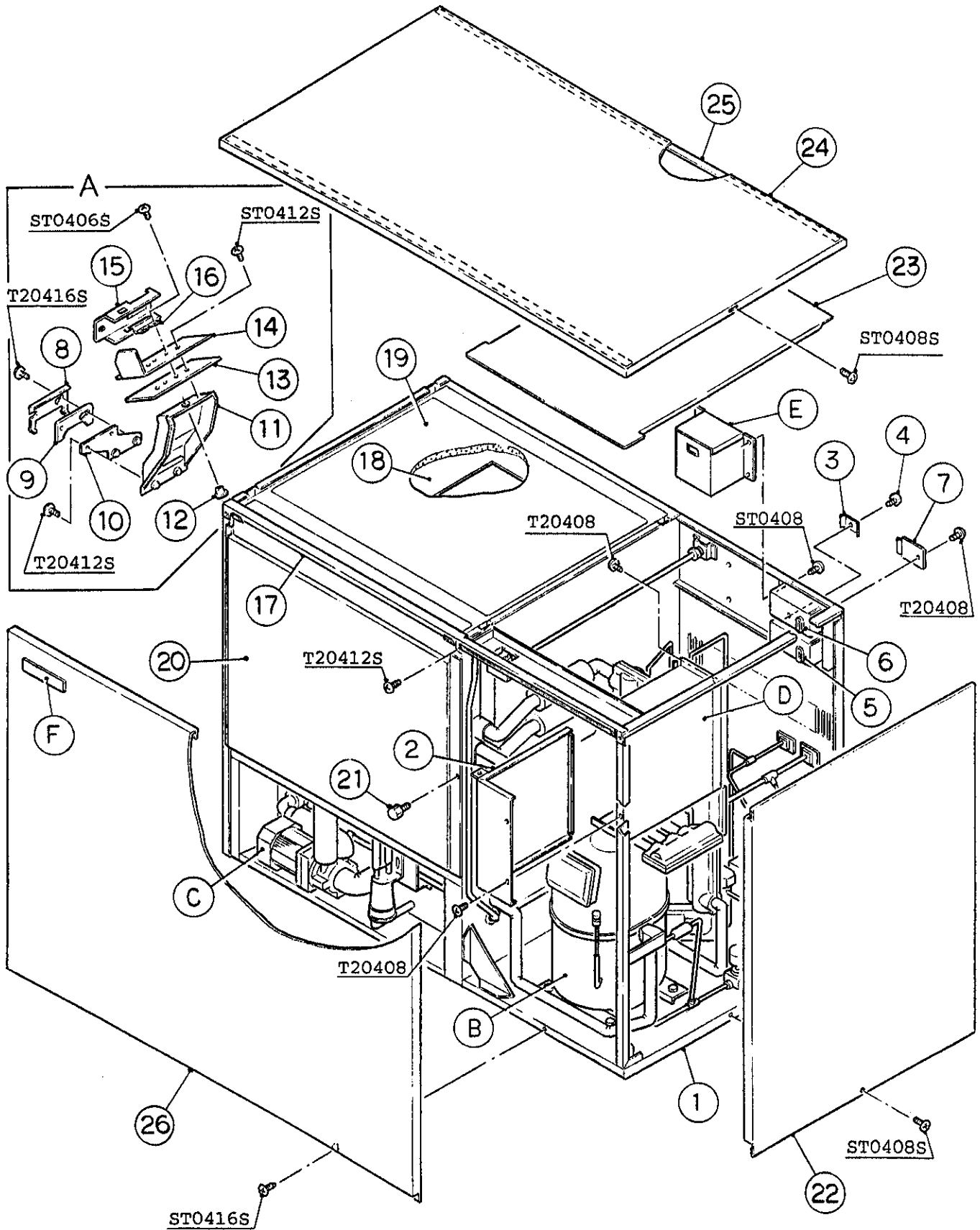

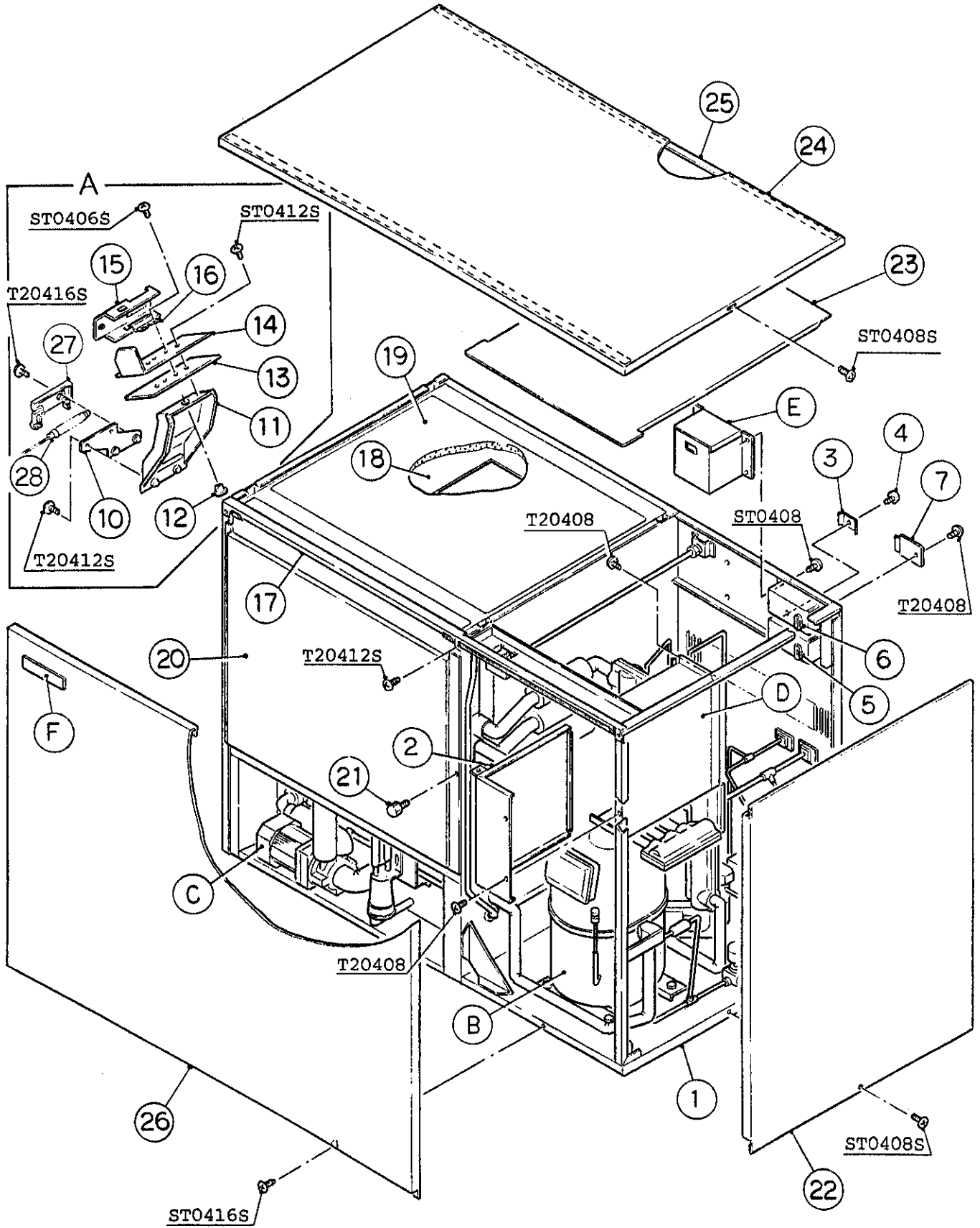

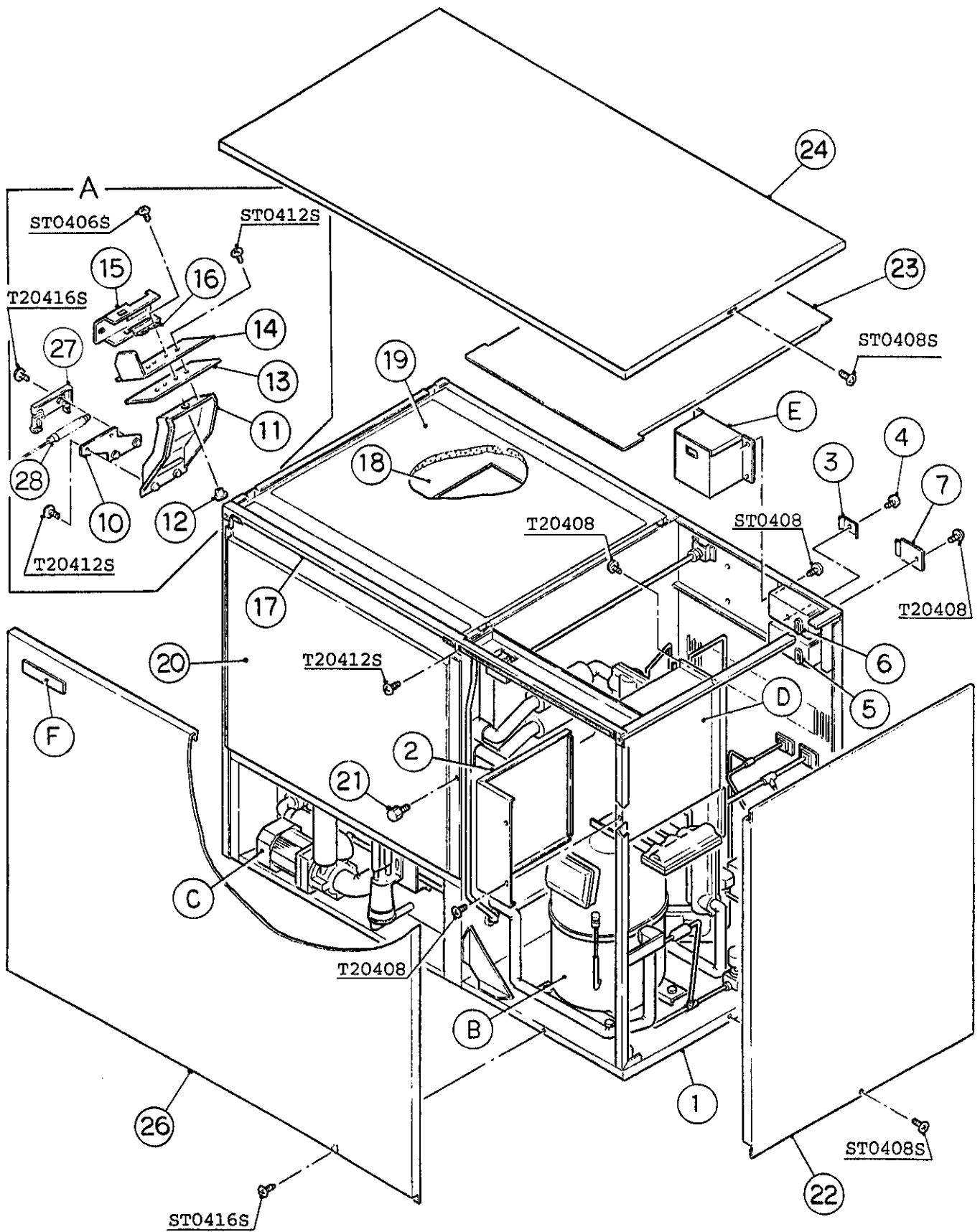

HA

KM-2400SRB3

A. ICE CUBER ASSEMBLY

C-1, D-0, E-0, E-1, F-0, G-0,
G-1, H-1, H-2, H-3, J-1

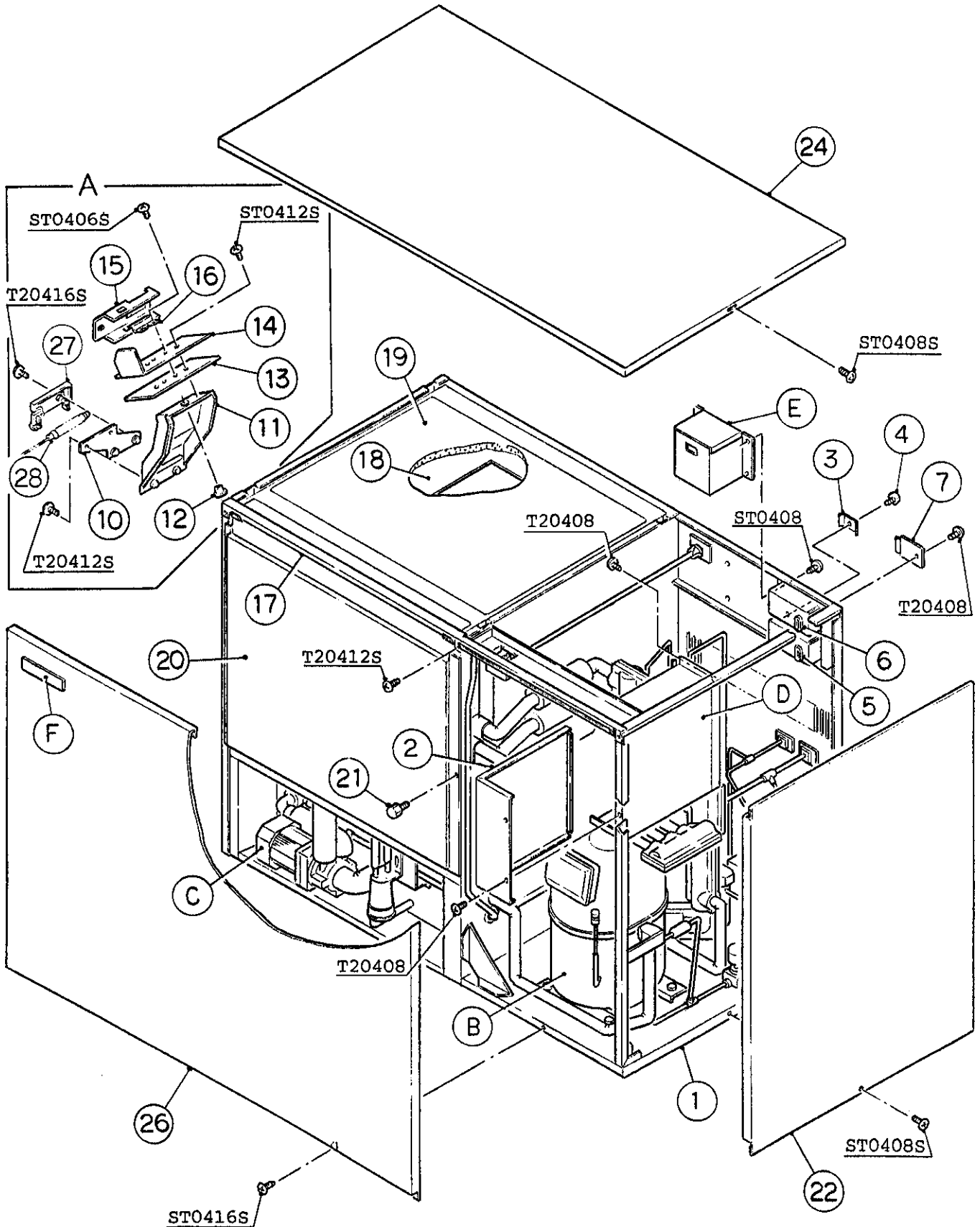

MODEL: KM-2400SRB3 TITLE: A. ICE CUBER ASSEMBLY														
INDEX NO.	DESCRIPTION	MATERIAL OR MODEL NUMBER	PART NUMBER	REQUIRED NUMBER										
				B-1	B-2	C-0	C-1	D-0 E-0	E-1	F-0 G-0 G-1	H-1	H-2	H-3	J-1
B	REFRIGERATION CIRCUIT	-	105287A01	1	1	x1								
		-	105287A02			o1	1	-						
		-	105287A03					1	-					
		-	105287A04						1	1	1	1	1	1
C	WATER CIRCUIT	-	105122A02	1	1	1	-							
		-	105122A03				1	1	-					
		-	105122A04						1	1	1	1	1	1
D	CONTROL BOX ASSEMBLY	-	215962A01	1	1	x1								
		-	215962A02			o1	1	1	1	1	-			
		-	215962A03								1	1	-	
		-	215962A04										1	1
E	TRANSFORMER BOX ASSEMBLY	-	326680A01	1	1	1	1	1	1	1	1	1	1	
F	LABEL LOCATION	-	326682A01	1	1	1	1	1	1	1	1	1	-	
		-	326682A02										1	1
1	EVAP. CASE	GS, SS	105861G03	1	1	1	1	1	-					
		GS, SS	105861G08						1	1	1	-		
		GS, SS	2A1102G05									1	1	-
		GS, SS	2A1102G10											1
2	CONTROL BOX COVER	GS	326681G01	1	1	x1								
		GS	3A0214-01			o1	1	1	1	1	-			
		GS	3A0851-01								1	1	1	1
3	SQUARE WASHER	BRASS	433537-02	2	2	2	2	2	2	2	2	2	2	
4	SCREW - GROUNDING	BRASS	433304-02	2	2	2	2	2	2	2	2	2	2	
5	BUSHING	SR-30-1	420472-03	1	1	1	1	1	1	1	1	1	1	
6	BUSHING	SR-31-2	420472-08	1	1	1	1	1	1	1	1	1	1	
7	JUNCTION BOX COVER	GS	433410-03	2	2	2	2	2	2	2	2	2	2	
8	BULB HOLDER (A)	SS	433707-01	1	-									
9	BULB HOLDER (B)	ABS	436549-01	1	-									

MODEL: KM-2400SRB3 TITLE: A. ICE CUBER ASSEMBLY													
INDEX NO.	DESCRIPTION	MATERIAL OR MODEL NUMBER	PART NUMBER	REQUIRED NUMBER									
				B-1	B-2	C-0	C-1	D-0	E-0 E-1	F-0 G-0 G-1	H-1	H-2	H-3
10	BULB HOLDER (C)	ABS	325845G01	1	1	1	1	1	1	1	1	1	1
11	BULB HOLDER (D)	ABS	215644G01	1	1	1	1	1	1	1	1	1	1
12	BUSHING	EP RUBBER	425307-01	1	1	1	1	1	1	1	1	1	1
13	SPACER	ABS	439727-01	1	1	1	1	1	1	1	1	1	1
14	BULB HOLDER (E)	GS	439725-01	1	1	1	1	1	1	1	1	1	1
15	BULB HOLDER (F)	GS	328743-01	1	1	1	1	1	1	1	1	1	1
16	BULB HOLDER (G)	GS	439726-01	1	1	1	1	1	1	1	1	1	1
17	FRONT PANEL - BRACKET	SS	323903-01	1	1	1	1	1	1	1	1	1	1
18	SPACER	ABS	324321-01	1	1	1	1	1	1	1	1	1	1
19	TOP INSULATION	ABS, PE	324216G01	1	1	1	1	1	1	1	1	1	1
20	FRONT INSULATION	ABS, PE	326041G01	1	1	1	1	1	1	1	1	1	1
21	THUMBSCREW	ABS, SS	415949G01	1	1	1	1	1	1	1	1	1	1
22	SIDE PANEL (R)	SS	215381G01	1	1	1	1	1	1	1	1	1	1
23	BARRIER	GS	325920-01	1	1	1	-						
24	TOP PANEL (A)	(324217A01)	213669-01	1	1	x1							
	TOP PANEL	SS	213669-01			o1	1	1	x1				
		SS	213669-02						o1	1	1	1	1
25	GASKET	(324217A01)	427014-03	2	2	-							
26	FRONT PANEL (A)	SS	215382-01	1	1	1	1	1	1	1	1	1	1
27	BULB HOLDER	PE	328919-01		1	1	1	1	1	1	1	1	1
28	SPACER	PE	443545-01		2	2	2	1	1	1	1	1	1

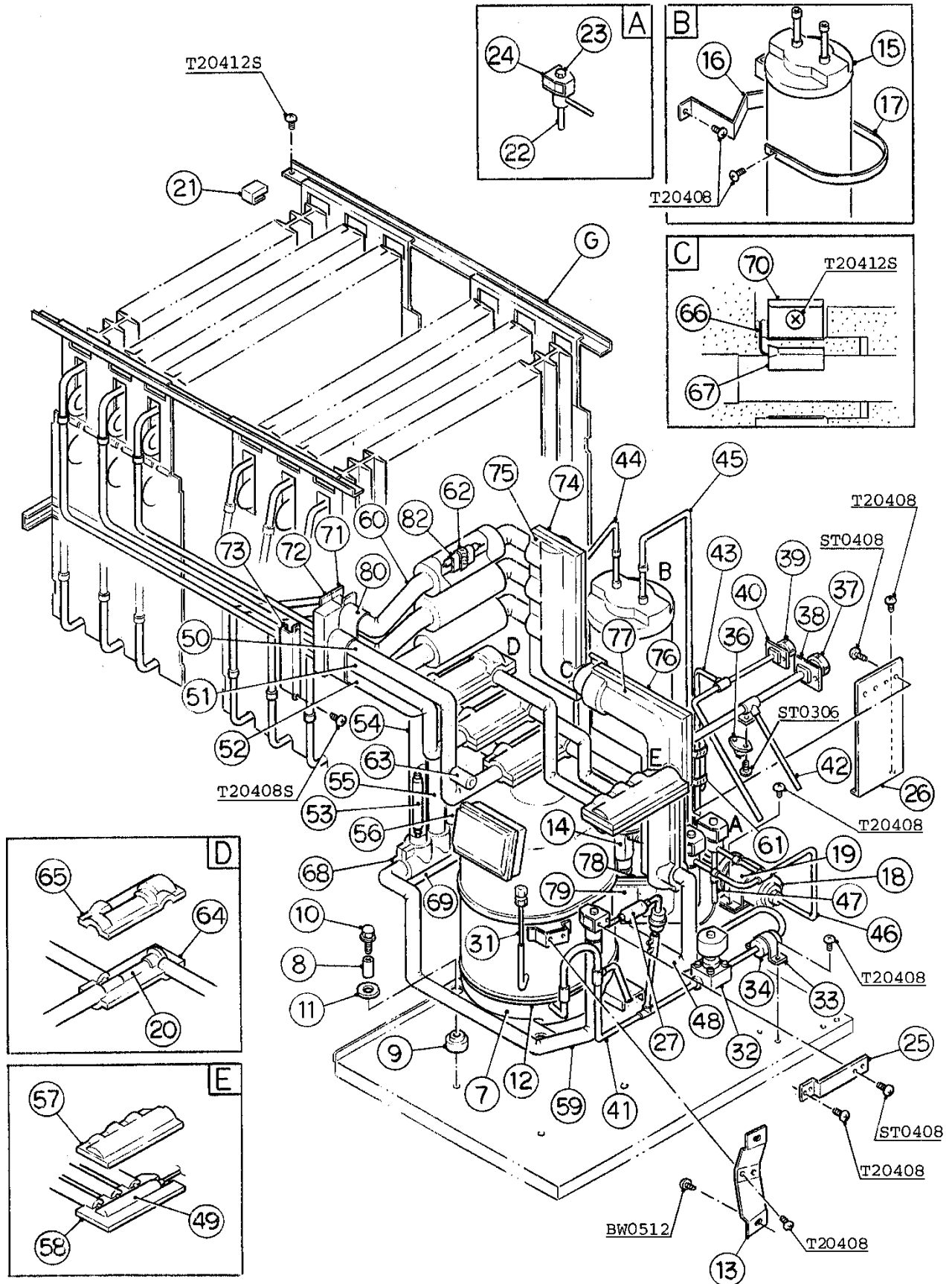

HA

KM-2400SRB3

B. REFRIGERATION CIRCUIT (2/2)

B-1, B-2, C-0, C-1, D-0, E-0
E-1, F-0, G-0, G-1, H-1, H-2,
H-3, J-1

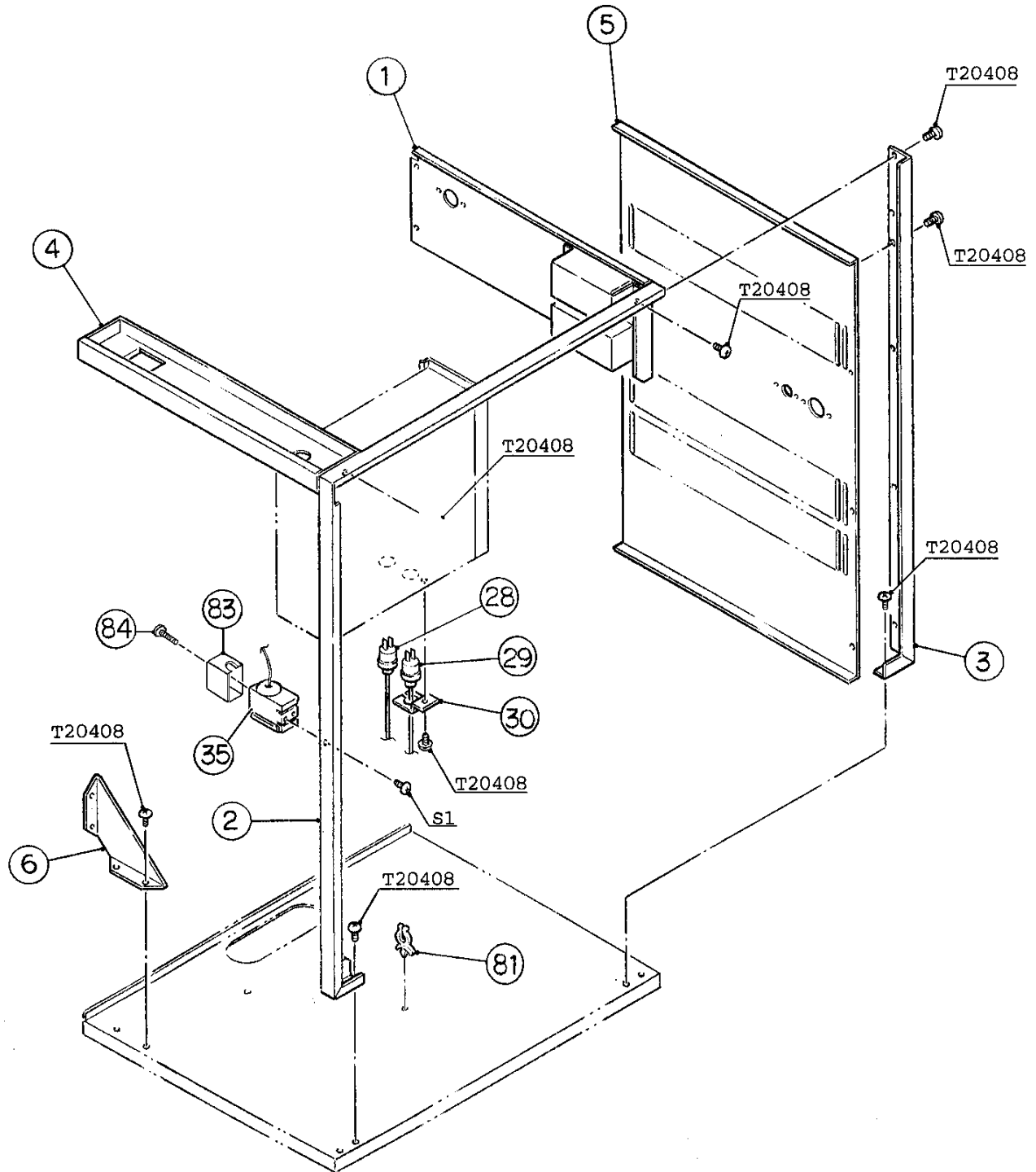

S1: Truss Head Screw 6-32unc x 5/16

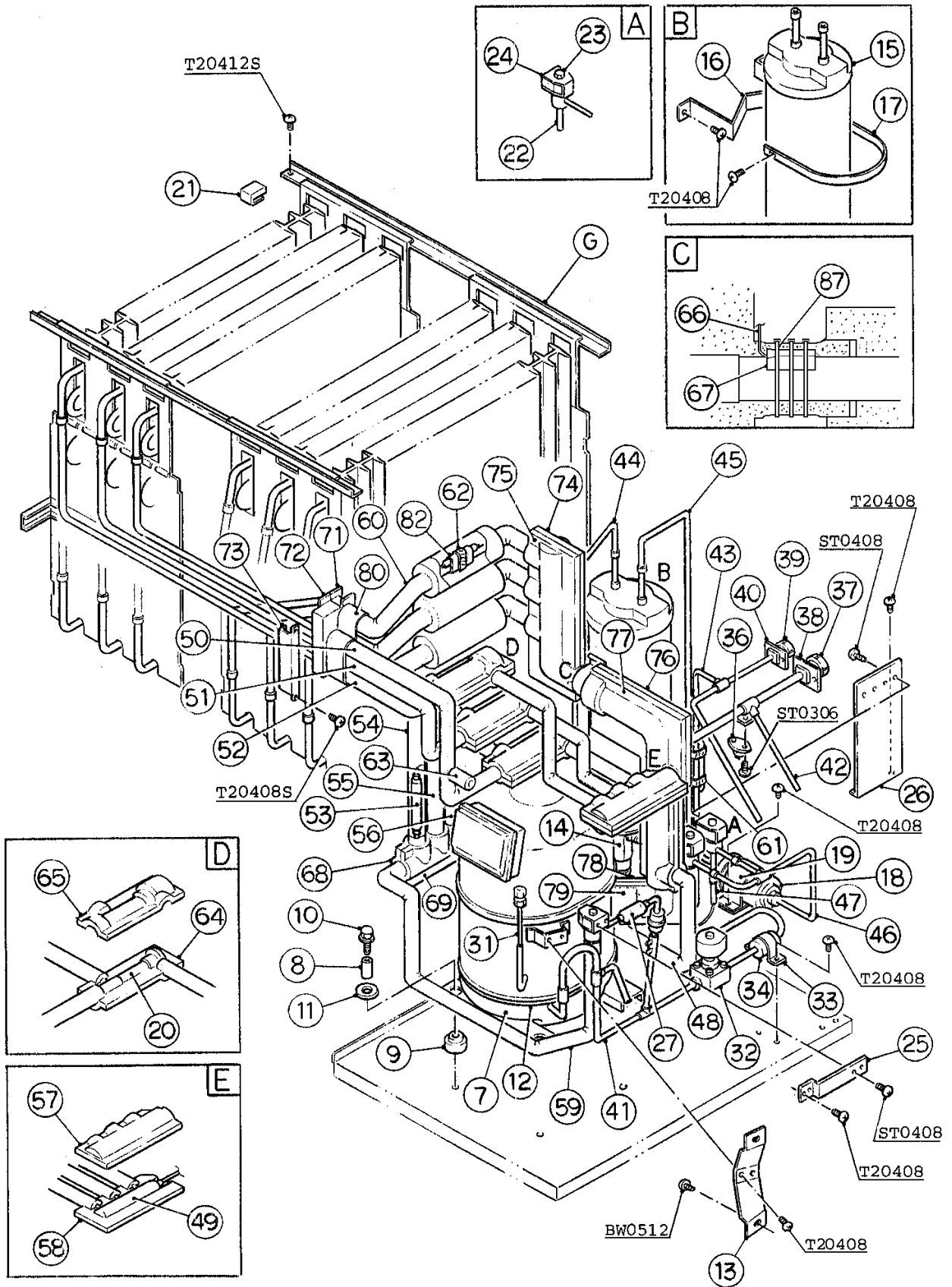

HA

KM-2400SRB3

B. REFRIGERATION CIRCUIT (1/2)

D-0, E-0, E-1, F-0, G-0,
G-1, H-1, H-2, H-3, J-1

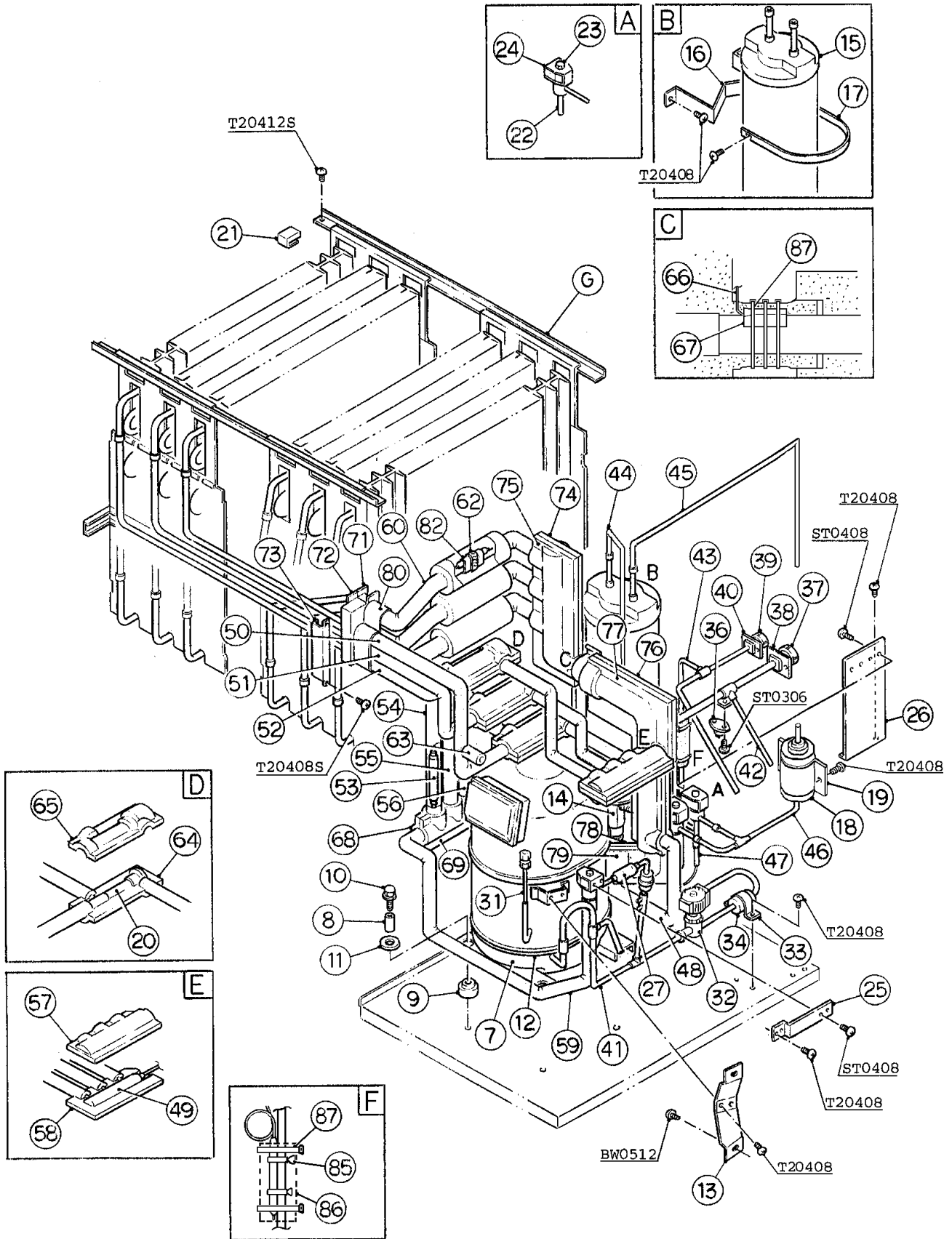

MODEL: KM-2400SRB3 TITLE: B. REFRIGERATION CIRCUIT													
INDEX NO.	DESCRIPTION	MATERIAL OR MODEL NUMBER	PART NUMBER	REQUIRED NUMBER									
				B-1	B-2	C-0	C-1	D-0	E-1	F-0	H-1	H-2	H-3
G	EVAPORATOR	-	105288A01	1	1	1	1	1	1	1	1	1	1
1	REAR FRAME	GS	326687G01	1	1	1	-						
		GS	326687G02				1	1	-				
		GS	326687G03						1	1	1	1	1
2	SIDE FRAME (A)	GS	215375G01	1	1	1	1	1	1	1	1	1	1
3	SIDE FRAME (B)	GS	215376G01	1	1	1	1	1	1	1	1	1	1
4	FRONT FRAME	GS	325857G01	1	1	x1							
		GS	325857-01			o1	1	1	1	1	1	1	1
5	REAR PANEL	GS	215965G01	1	1	x1							
	REAR PANEL (A)	GS	215973-01			o1	1	1	1	1	1	1	1
6	BRACE	GS	325858-01	1	1	1	1	1	1	1	1	1	1
7	COMPRESSOR	TM506JA-U	440665-01	1	1	1	1	1	1	1	1	1	1
8	COLLAR	-	432808-01	4	4	4	4	4	4	4	4	4	4
9	RUBBER CUSHION (L)	CR	442323-01	4	4	4	4	4	4	4	4	4	4
10	BOLT	8x45	437889-01	4	4	4	4	4	4	4	4	4	4
11	RUBBER CUSHION (U)	CR	442324-01	4	4	4	4	4	4	4	4	4	4
12	CRANKCASE HEATER	CH-5700	440365-01	1	1	1	1	1	1	1	1	1	1
13	COMP. BRACKET	GS	328290-01	1	1	1	1	1	1	1	1	1	1
14	C. P. REGULATOR	LAC-5	440466-01	1	-								
		-	443522-01		1	1	1	1	1	1	1	1	1
15	RECEIVER	RR MN WP 450	440366-01	1	1	1	1	1	1	1	1	1	1
16	RECEIVER BRACKET (A)	GS	327093-01	1	1	1	1	1	1	1	1	1	1
17	RECEIVER BRACKET (B)	GS	440860-01	1	1	1	1	1	1	1	1	1	1
18	DRIER	DM2-Y903HDU-1	439676-01	1	1	1	1	x1					
		C-530-S	445011-01					o1	1	1	1	1	1
19	DRIER BRACKET	GS	438211-01	1	1	1	1	x1					
		GS	445251-01					o1	1	1	1	1	1
20	EXP. VALVE	HFE-E15HHDU-1	440367-01	3	3	3	3	3	3	3	3	3	3

MODEL: KM-2400SRB3 TITLE: B. REFRIGERATION CIRCUIT													
INDEX NO.	DESCRIPTION	MATERIAL OR MODEL NUMBER	PART NUMBER	REQUIRED NUMBER									
				B-1	B-2	C-0	C-1	D-0 E-0	E-1	F-0 G-0 G-1	H-1	H-2	H-3
21	FRAME SEAL	EPDM	323925-01	4	4	4	4	4	4	4	4	4	4
22	VALVE BODY	70	440352-01	3	3	3	3	3	3	3	3	3	3
23	BOLT	4x6	440353F01	3	3	3	3	3	3	3	3	3	3
24	COIL - VALVE	ABS-25-1-HD-2	440353-01	3	3	3	3	3	3	3	3	3	3
25	LINE VALVE BRACKET	GS	438213-01	1	1	1	1	1	1	1	1	1	1
26	VALVE BRACKET	GS	440368-01	1	1	1	1	1	1	1	1	1	1
27	STRAINER	-	430365-05	1	1	1	1	1	x1				
		-	441569-02						o1	1	1	1	1
28	PRESSURE SWITCH	ACB-2UB04	433441-05	1	1	1	1	1	1	1	1	1	1
29	PRESSURE SWITCH	ACB-2UB02	433441-01	1	1	1	1	1	1	1	1	1	1
30	PRESSURE SWITCH BRCKT.	GS	434938-01	2	2	2	2	2	2	2	2	2	2
31	ACCESS VALVE	TCJ-2F15-HD	417366-01	1	1	1	1	1	1	1	1	1	1
32	SOLENOID VALVE	BPS-RY4-HD-1	2U0131-01	1	1	1	1	-					
		OE-10S241-22	4A0582-01					1	1	1	1	1	1
33	TUBE HOLDER	GS	440891-01	1	1	1	1	-					
		GS	4A0631-01					1	1	1	1	1	1
34	INSULATION TUBE	L=40	7762-1630	1	1	1	1	-					
		L=40	7762-3555					1	1	1	1	1	1
35	PRESSURE SWITCH	G20-4149-00	440388-01	1	1	1	1	1	1	1	1	1	1
36	THERMOSTAT	CS-12A	440664-01	1	1	1	1	1	1	1	1	1	1
37	COUPLING	COPPER	434136G01	1	1	1	1	1	1	1	1	1	1
38	TUBE HOLDER (L)	GS	438245-01	1	1	1	1	1	1	1	1	1	1
39	COUPLING	COPPER	433751G01	1	1	1	1	1	1	1	1	1	1
40	TUBE HOLDER (S)	GS	438246-01	1	1	1	1	1	1	1	1	1	1
41	COPPER TUBE (A) - HIGH SIDE	COPPER	326688G01	1	1	1	1	-					
		COPPER	3A0378G01					1	1	1	1	1	1
42	COPPER TUBE (B) - HIGH SIDE	COPPER	215966G01	1	1	1	1	-					
		COPPER	2A0398G01					1	1	1	1	1	1

MODEL: KM-2400SRB3 TITLE: B. REFRIGERATION CIRCUIT													
INDEX NO.	DESCRIPTION	MATERIAL OR MODEL NUMBER	PART NUMBER	REQUIRED NUMBER									
				B-1	B-2	C-0	C-1	D-0 E-0	E-1	F-0 G-0 G-1	H-1	H-2	H-3
43	COPPER TUBE (C) - HIGH SIDE	COPPER	326689G01	1	1	1	1	1	1	1	1	1	1
44	COPPER TUBE (D) - HIGH SIDE	COPPER	3A0119G01	1	1	1	1	-					
		COPPER	3A0224-01					1	1	1	1	1	1
45	COPPER TUBE (E) - HIGH SIDE	COPPER	440370-01	1	1	1	1	-					
		COPPER	3A0221-01					1	1	1	1	1	1
46	COPPER TUBE (F) - HIGH SIDE	COPPER	326691G01	1	1	1	1	1	1	1	1	1	1
47	COPPER TUBE - BYPASS	COPPER	440371G01	1	1	1	1	1	1	1	1	1	1
48	HEAT EXCHANGER	COPPER	215967G01	1	1	1	1	1	1	1	1	1	1
49	COPPER TUBE (J) - HIGH SIDE	COPPER	326692G01	1	1	1	1	1	1	1	1	1	1
50	COPPER TUBE (A) - LOW SIDE	COPPER	326693G01	1	1	1	1	1	1	1	1	1	1
51	COPPER TUBE (B) - LOW SIDE	COPPER	326694G01	1	1	1	1	1	1	1	1	1	1
52	COPPER TUBE (C) - LOW SIDE	COPPER	326695G01	1	1	1	1	1	1	1	1	1	1
53	CHECK VALVE	YCV5-3	425342-02	3	x3								
		YCV5-3S	425342-04		o3	3	3	3	3	3	3	3	3
54	INSULATION TUBE	L=350	7762-1323	1	1	1	1	1	1	1	1	1	1
55	INSULATION TUBE	L=330	7762-1323	1	1	1	1	1	1	1	1	1	1
56	INSULATION TUBE	L=310	7762-1323	1	1	1	1	1	1	1	1	1	1
57	HEADER COVER (C1)	PE FOAM	326815-01	1	1	1	1	1	1	1	1	1	1
58	HEADER COVER (C2)	PE FOAM	326815-02	1	1	1	1	1	1	1	1	1	1
59	COPPER TUBE - HOT GAS	COPPER	215969G01	1	1	1	1	1	1	1	1	1	1
60	COPPER TUBE - LOW SIDE	COPPER	215968G01	1	1	1	1	1	1	1	1	1	1
61	CLAMP	D11-SS	435254-03	2	2	2	2	-					
62	CLAMP	-	443461-01	3	3	3	3	3	3	3	3	3	3
63	INSULATION TUBE	L=40	7762-1020	2	2	2	2	2	2	2	2	2	2
64	EXP. VALVE COVER (A)	PE FOAM	326697-01	3	3	3	3	3	3	3	3	3	3
65	EXP. VALVE COVER (B)	PE FOAM	326697-02	3	3	3	3	3	3	3	3	3	3
66	THERMISTOR	-	429006-03	1	1	1	1	1	1	1	1	1	1
67	THERMISTOR HOLDER	-	435563-01	1	1	1	1	1	1	1	1	1	1

MODEL: KM-2400SRB3 TITLE: B. REFRIGERATION CIRCUIT														
INDEX NO.	DESCRIPTION	MATERIAL OR MODEL NUMBER	PART NUMBER	REQUIRED NUMBER										
				B-1	B-2	C-0	C-1	D-0 E-0	E-1	F-0 G-0 G-1	H-1	H-2	H-3	J-1
68	HEADER COVER (B1)	PE FOAM	326698-01	1	1	1	1	1	1	1	1	1	1	
69	HEADER COVER (B2)	PE FOAM	326698-02	1	1	1	1	1	1	1	1	1	1	
70	STRAP - THERMISTOR	SS	440373-01	1	-									
71	RUBBER INSULATION (A)	EPDM (BLACK)	326700-01	1	1	1	1	1	1	1	1	1	1	
72	RUBBER INSULATION (B)	EPDM (BLACK)	326701-01	1	1	1	1	1	1	1	1	1	1	
73	INSULATION HOLDER	SS	325863-01	1	1	1	1	1	1	1	1	1	1	
74	HEADER COVER (A1)	PE FOAM	327839-01	1	1	1	1	1	1	1	1	1	1	
75	HEADER COVER (A2)	PE FOAM	327839-02	1	1	1	1	1	1	1	1	1	1	
76	HEAT EXCHANGER CVR. (A1)	PE FOAM	326699-01	1	1	1	1	1	1	1	1	1	1	
77	HEAT EXCHANGER CVR. (A2)	PE FOAM	326699-02	1	1	1	1	1	1	1	1	1	1	
78	HEAT EXCHANGER CVR. (B1)	PE FOAM	440374-01	1	1	1	1	1	1	1	1	1	1	
79	HEAT EXCHANGER CVR. (B2)	PE FOAM	440374-02	1	1	1	1	1	1	1	1	1	1	
80	INSULATION	PE FOAM	436671-02	1	1	1	1	1	1	1	1	1	1	
81	CLAMP	NO.249	427902-03	3	3	3	3	3	3	3	3	3	3	
82	HOLDER / EXP.VALVE - 1/2	SS	3A0112-01	3	3	3	3	3	3	3	3	3	3	
83	TERMINAL COVER	Ranco 322878-1	440388F01	1	1	1	1	1	1	1	1	1	1	
84	TERMINAL COVER SCREW	Ranco 114021-8	440388F02	1	1	1	1	1	1	1	1	1	1	
85	CLAMP	-	443461-02					2	2	2	2	2	2	
86	INSULATION TUBE	L=200	7762-2943					1	1	1	1	1	1	
87	CABLE TIE	CV-200	7920-0010		3	3	3	5	5	5	5	5	5	

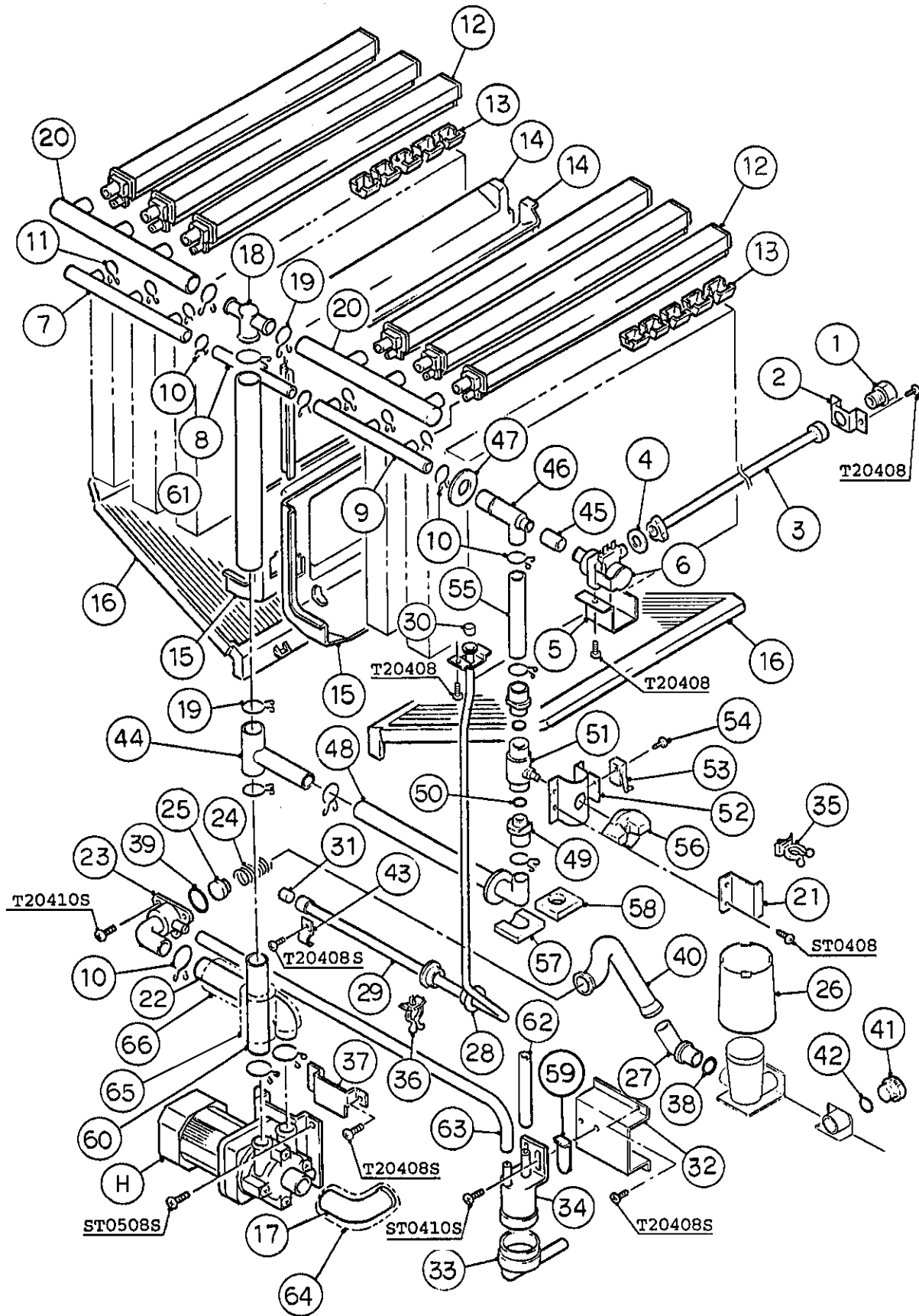

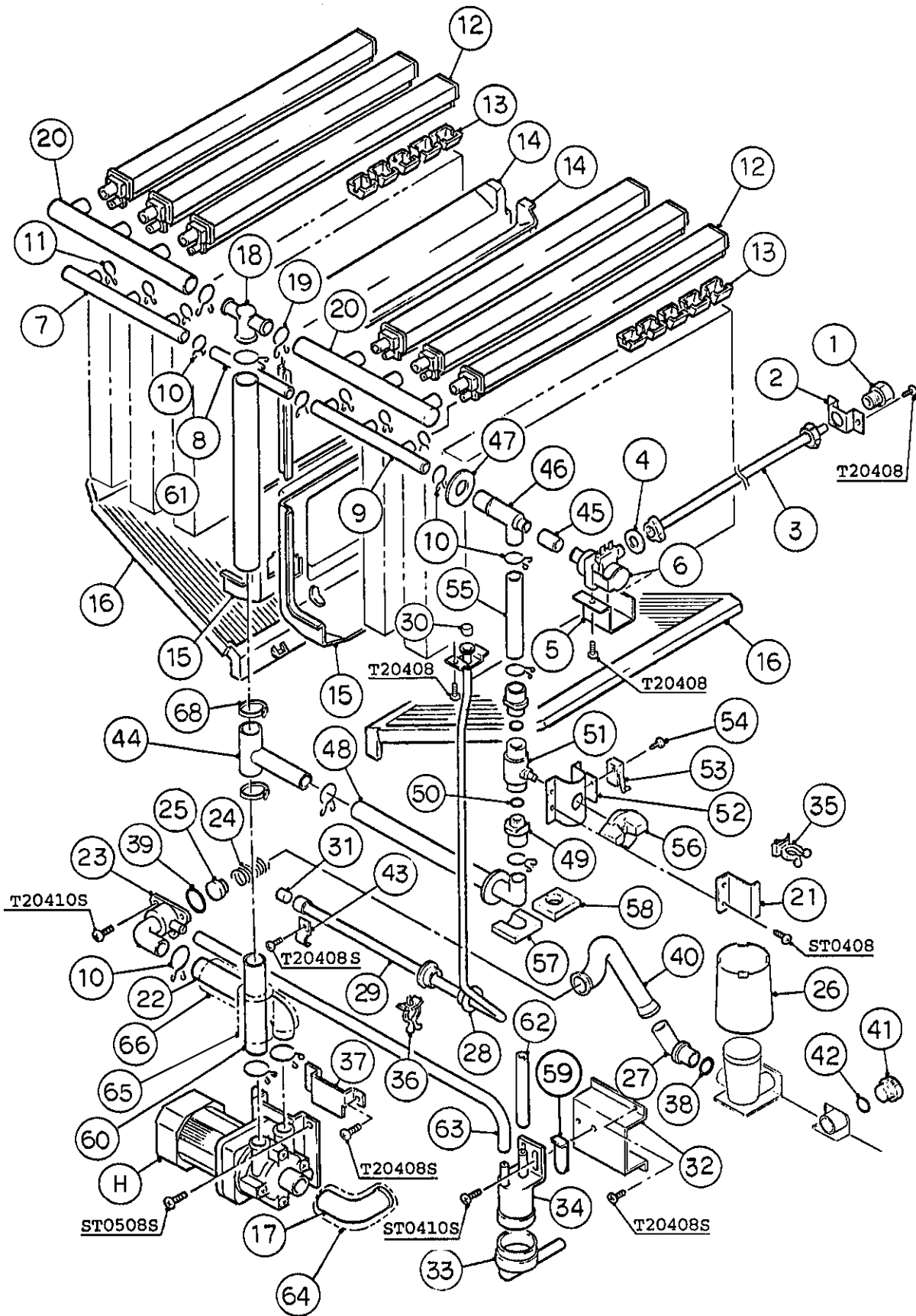

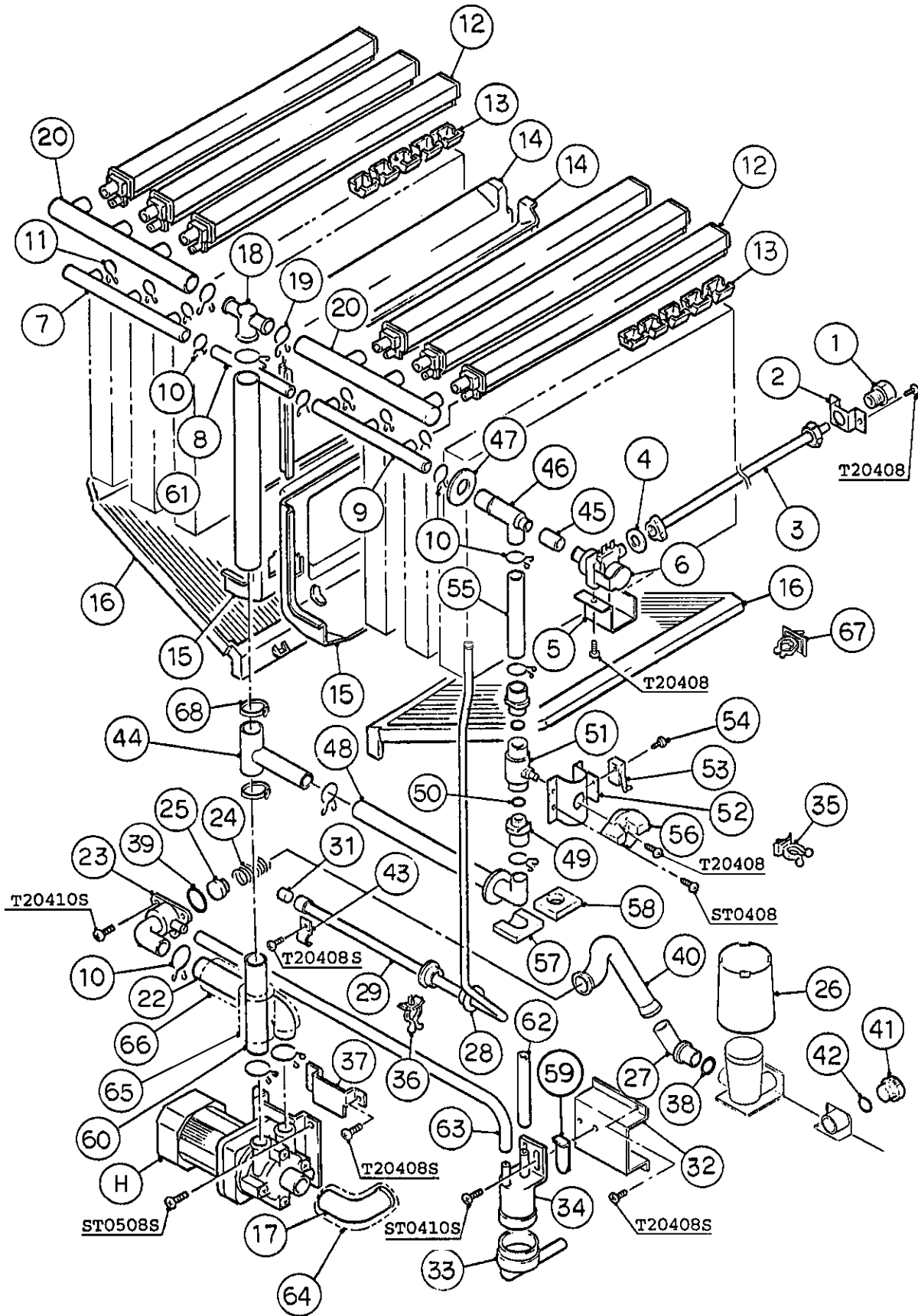

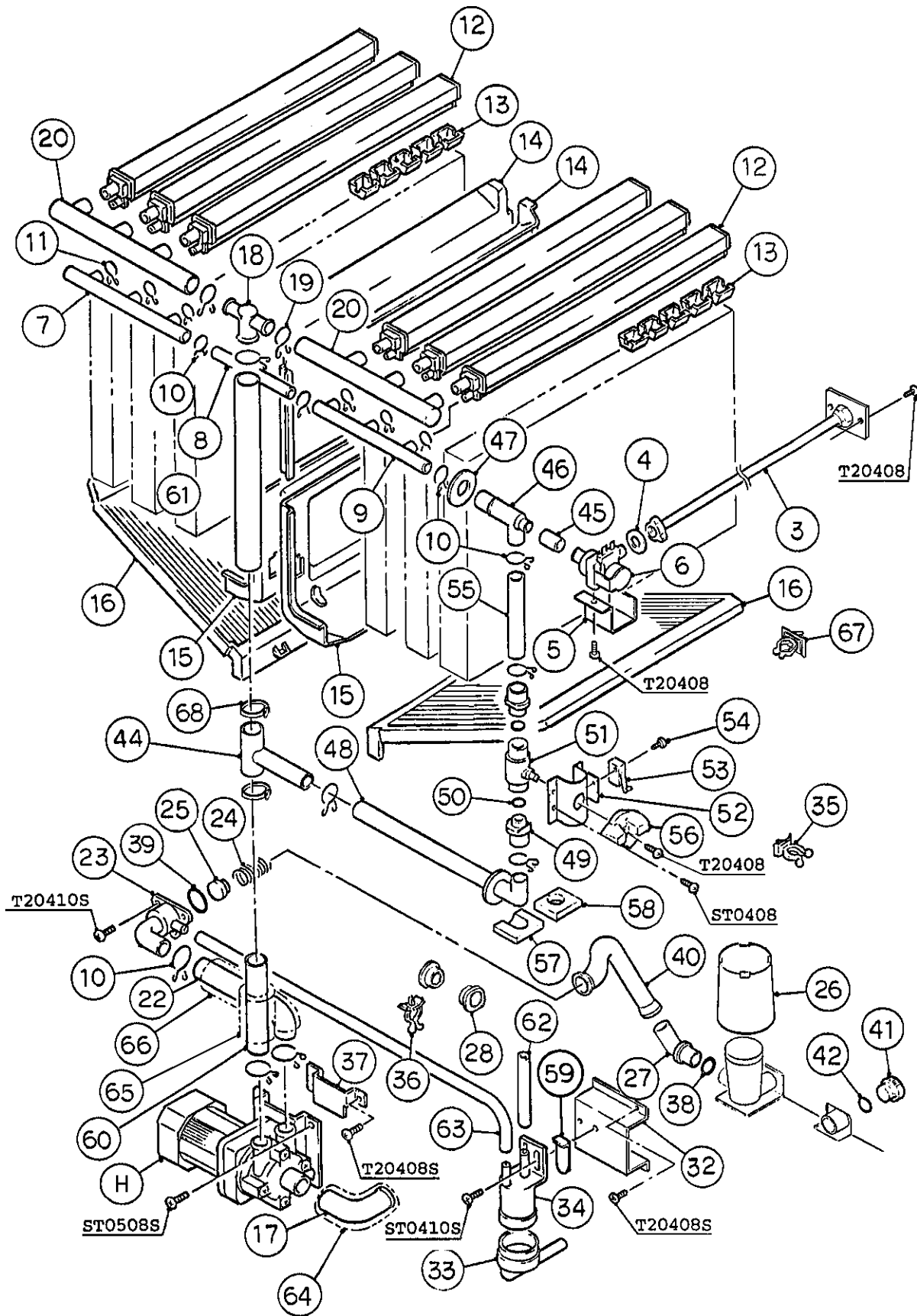

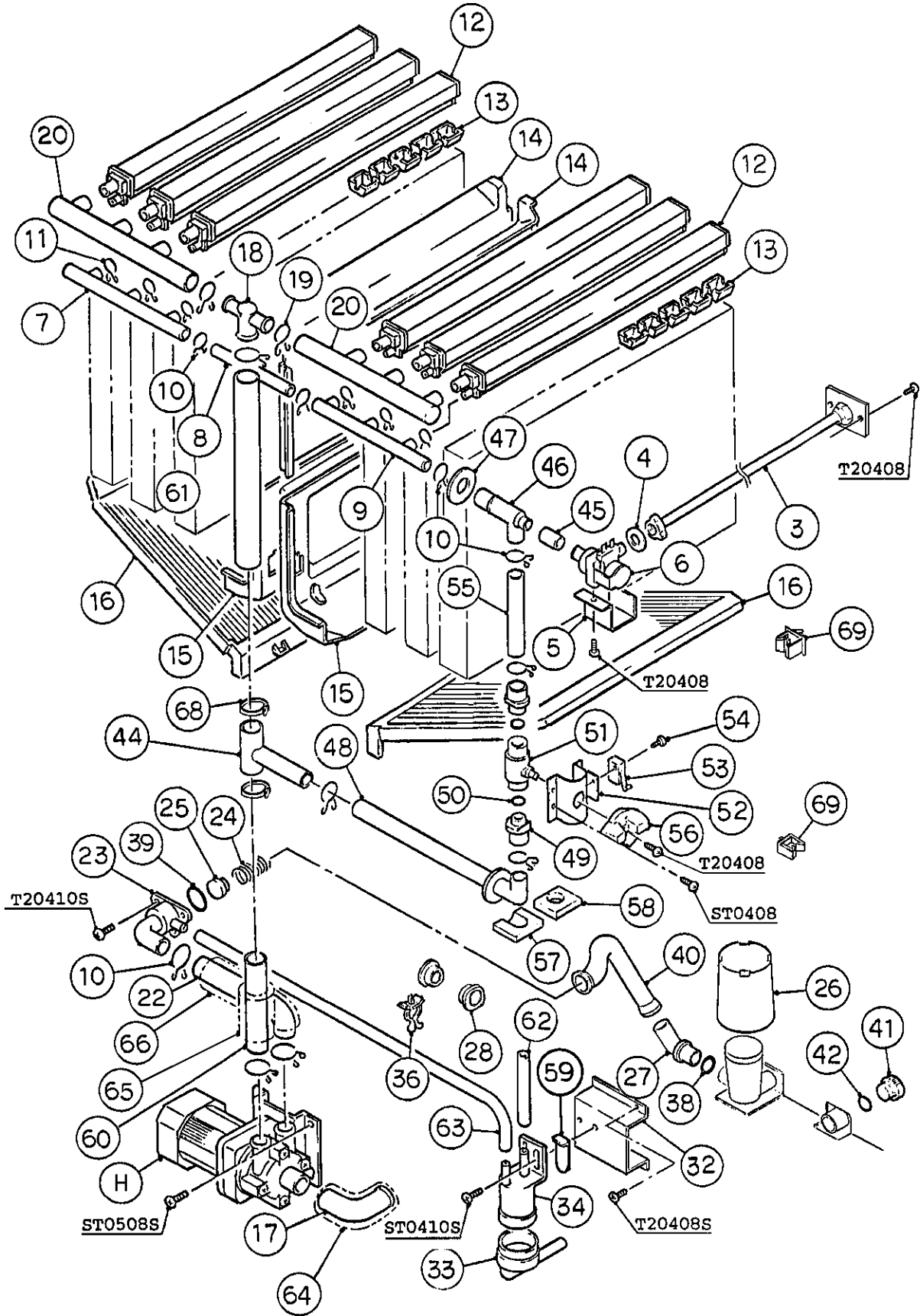

HA

KM-2400SRB3

C. WATER CIRCUIT

E-1, F-0, G-0, G-1
H-1, H-2, H-3, J-1

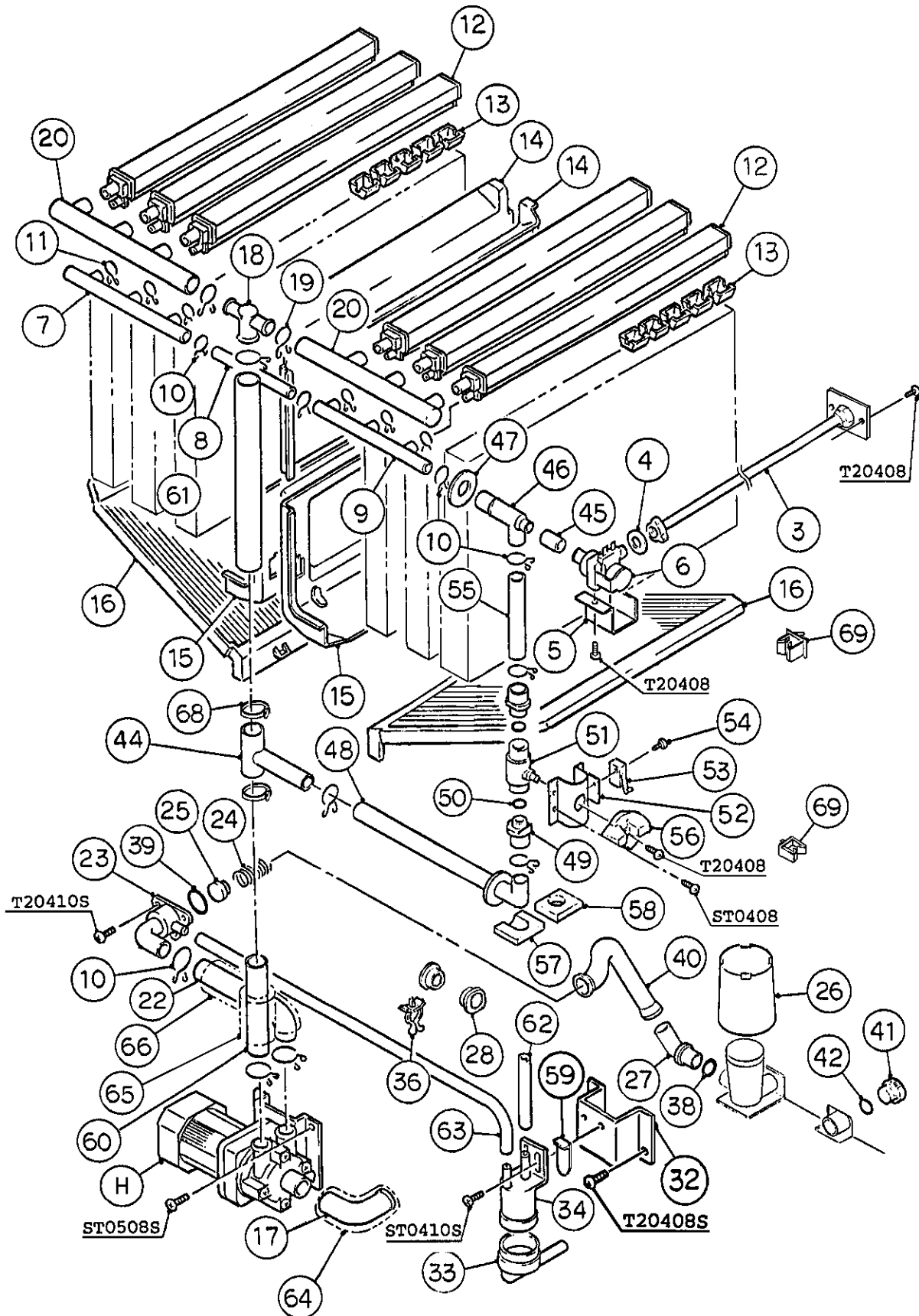

MODEL: KM-2400SRB3 TITLE: C. WATER CIRCUIT														
INDEX NO.	DESCRIPTION	MATERIAL OR MODEL NUMBER	PART NUMBER	REQUIRED NUMBER										
				B-1	B-2	C-0	C-1	D-0 E-0	E-1	F-0 G-0 G-1	H-1	H-2	H-3	J-1
H	PUMP MOTOR ASSEMBLY	(S-0730)	215692A01	1	1	1	1	1	1	1	1	1	1	1
1	FITTING - INLET	BRASS	436552-01	1	1	1	-							
2	FITTING HOLDER - INLET	GS	436550-01	1	1	1	-							
3	WATER SUPPLY PIPE	COPPER	436670G02	1	x1									
		COPPER	4A0156G03		o1	1	-							
		COPPER	4A0207G03				1	1	-					
		COPPER	4A0768G03						1	1	1	1	1	1
4	RUBBER GASKET	NBR	413854-01	2	2	2	1	1	x1					
		SI. R	413854-03						o1	1	1	1	1	1
5	WATER VALVE BRACKET	GS	321443-01	1	1	1	1	1	1	1	1	1	1	1
6	WATER VALVE	J248-106	3U0136-01	1	1	1	1	1	1	1	1	1	1	1
7	DISTRIBUTOR HOSE (A)	EPDM	325738-01	1	1	1	1	1	1	1	1	1	1	1
8	JOINT PIPE	ABS	439297-01	1	1	1	1	1	1	1	1	1	1	1
9	DISTRIBUTOR HOSE (B)	EPDM	325738-02	1	1	1	1	1	1	1	1	1	1	1
10	HOSE CLAMP	SS, 25 mm.	427443-03	9	9	9	9	9	9	9	9	9	9	9
11	HOSE CLAMP	SS, 13.5 mm.	427443-07	6	6	6	6	6	6	6	6	6	6	6
12	SPRAY TUBE	ABS	437049G03	6	6	x6								
		ABS	437049G01			o6	6	6	6	6	6	6	6	6
13	SPRAY GUIDE (A)	PE	208586-01	18	18	18	18	18	18	18	18	18	18	18
14	SEPARATOR (A)	ABS	215046-01	2	2	2	2	2	2	2	2	2	2	2
15	SEPARATOR (B)	ABS	213623G01	2	2	x2								
		ABS	2A0100-01			o2	2	2	2	2	2	2	2	2
16	CUBE GUIDE	ABS	214243-01	2	2	2	2	2	2	2	2	2	2	2
17	HOSE (A)	EPDM	435091-01	1	1	1	1	1	1	1	1	1	1	1
18	DISTRIBUTOR (A)	ABS	439266-01	1	1	1	1	1	1	1	1	1	1	1
19	HOSE CLAMP	SS, 32 mm.	427443-09	6	3	4	4	4	4	4	4	4	4	4
20	DISTRIBUTOR HOSE (C)	EPDM	325739-01	2	2	2	2	2	2	2	2	2	2	2
21	HANDLE BRACKET	GS	439929-01	1	1	1	1	1	1	1	1	1	1	1

MODEL: KM-2400SRB3 TITLE: C. WATER CIRCUIT													
INDEX NO.	DESCRIPTION	MATERIAL OR MODEL NUMBER	PART NUMBER	REQUIRED NUMBER									
				B-1	B-2	C-0	C-1	D-0 E-0	E-1	F-0 G-0 G-1	H-1	H-2	H-3
22	HOSE (B)	EPDM	325867-01	1	1	1	1	1	1	1	1	1	1
23	VALVE HOUSING - DRAIN	ABS	323613-01	1	1	1	1	1	1	1	1	1	1
24	SPRING	SS	322685-01	1	1	1	1	1	1	x1			
		SS	322110-01							o1	1	1	1
25	VALVE SHEET	EPDM	433705-01	1	1	1	1	1	1	1	1	1	1
26	OVERFLOW CAP	PE	325866-01	1	1	1	1	1	1	1	1	1	1
27	JOINT - OVERFLOW	ABS	323923-02	1	1	1	1	1	1	1	1	1	1
28	BUSHING	SB-1093-15	420470-03	2	2	2	2	2	2	2	2	2	2
29	CONDUIT	COPPER	325870G01	1	1	x1							
		COPPER	4A0332-01			o1	1	-					
30	BUSHING	SB-625-8	420470-01	1	1	-							
31	BUSHING	OCB-500	428394-02	1	1	x1							
		OCB-437	428394-06			o1	1	-					
32	FLOAT SW. BRACKET	SS	325846-01	1	1	1	1	1	-				
		SS	3A0449-01						1	1	1	1	1
33	CONNECTOR - FLOAT SW.	EPDM	426799-04	1	1	1	1	1	1	1	1	1	x1
		-	3A1325-03										o1
34	FLOAT SWITCH	FS-0893B-1	433535-02	1	1	1	1	1	1	x1			
		163795	4A0886-01							o1	1	1	1
35	CLAMP	NO. 248	427902-04	6	6	6	6						
36	CLAMP	NO.4253	427902-05	1	1	1	1	1	1	1	1	1	1
37	BARRIER	SS	436913-01	1	1	1	1						
38	"O" RING	1AP18	7611-P018	1	1	1	1	1	1	1	1	1	1
39	"O" RING	1AG35	7611-G035	1	1	1	1	1	1	1	1	1	1
40	DRAIN HOSE	EPDM	325869-01	1	1	1	1	1	1	1	1	1	1
41	DRAIN	AC	309246-01	1	1	1	1	1	1	1	1	1	1
42	"O" RING	1AP15	7611-P015	1	1	1	1	1	1	1	1	1	1
43	"C" CLAMP	CCO-12	7910C1200	1	1	1	-						

MODEL: KM-2400SRB3 TITLE: C. WATER CIRCUIT													
INDEX NO.	DESCRIPTION	MATERIAL OR MODEL NUMBER	PART NUMBER	REQUIRED NUMBER									
				B-1	B-2	C-0	C-1	D-0 E-0	E-1	F-0 G-0 G-1	H-1	H-2	H-3
44	DISTRIBUTOR (C)	ABS	439238-01	1	1	1	1	1	1	1	1	1	1
45	JOINT HOSE	EPDM	439296-01	1	1	1	1	1	1	1	1	1	1
46	DISTRIBUTOR (B)	ABS	439239-01	1	1	1	1	1	1	1	1	1	1
47	FLANGE	EPDM	439267-02	1	1	1	1	1	1	1	1	1	1
48	BY-PASS HOSE	EPDM	439237-02	1	1	1	1	1	1	1	1	1	1
49	MALE ADAPTOR	ABS, (S-0761)	325826-01	2	2	2	2	2	2	2	2	2	2
50	"O" RING	1AP18, (S-0761)	7611-P018	2	2	2	2	2	2	2	2	2	2
51	BALL VALVE	PVC, (S-0761)	439293-01	1	1	1	1	1	1	1	1	1	1
52	VALVE HOLDER	GS	325825-01	1	1	1	1	1	1	1	1	1	1
		-	3A1178-01										
53	MICRO SWITCH	AH-8064	436386-01	1	1	x1							
		ABV1636614F01	444193-01			o1	x1						
		V3L-III-D8	4A0365-01				o1	1	1	1	1	1	1
54	TAPPING SCREW	3 x 14	431415-02	2	2	2	2	2	2	2	2	2	2
55	JOINT HOSE	EPDM	439309-01	1	1	1	1	1	1	1	1	1	1
56	HANDLE	PP	215383-01	1	1	1	1	1	1	1	1	1	1
57	CORNER INSULATION (A)	PE	439376-01	1	1	1	1	1	1	1	1	1	1
58	CORNER INSULATION (B)	PE	439392-01	1	1	1	1	1	1	1	1	1	1
59	FLOAT SWITCH STOP	SS	4A0137-01	1	1	1	1	1	1	1	1	1	1
60	VINYL HOSE	L=230	7716-2732	1	1	1	1	1	1	1	1	1	1
61	VINYL HOSE	L=550	7716-2732	1	1	1	1	1	1	1	1	1	1
62	VINYL HOSE	L=190	7716-0913	1	1	1	1	1	1	1	x1		
	SILICONE HOSE	L=190	7730I3812								o1	1	1
63	VINYL HOSE	L=430	7716-0913	1	1	1	1	1	1	1	1	1	1
	SILICONE HOSE	L=430	7730I3896								o1	1	1

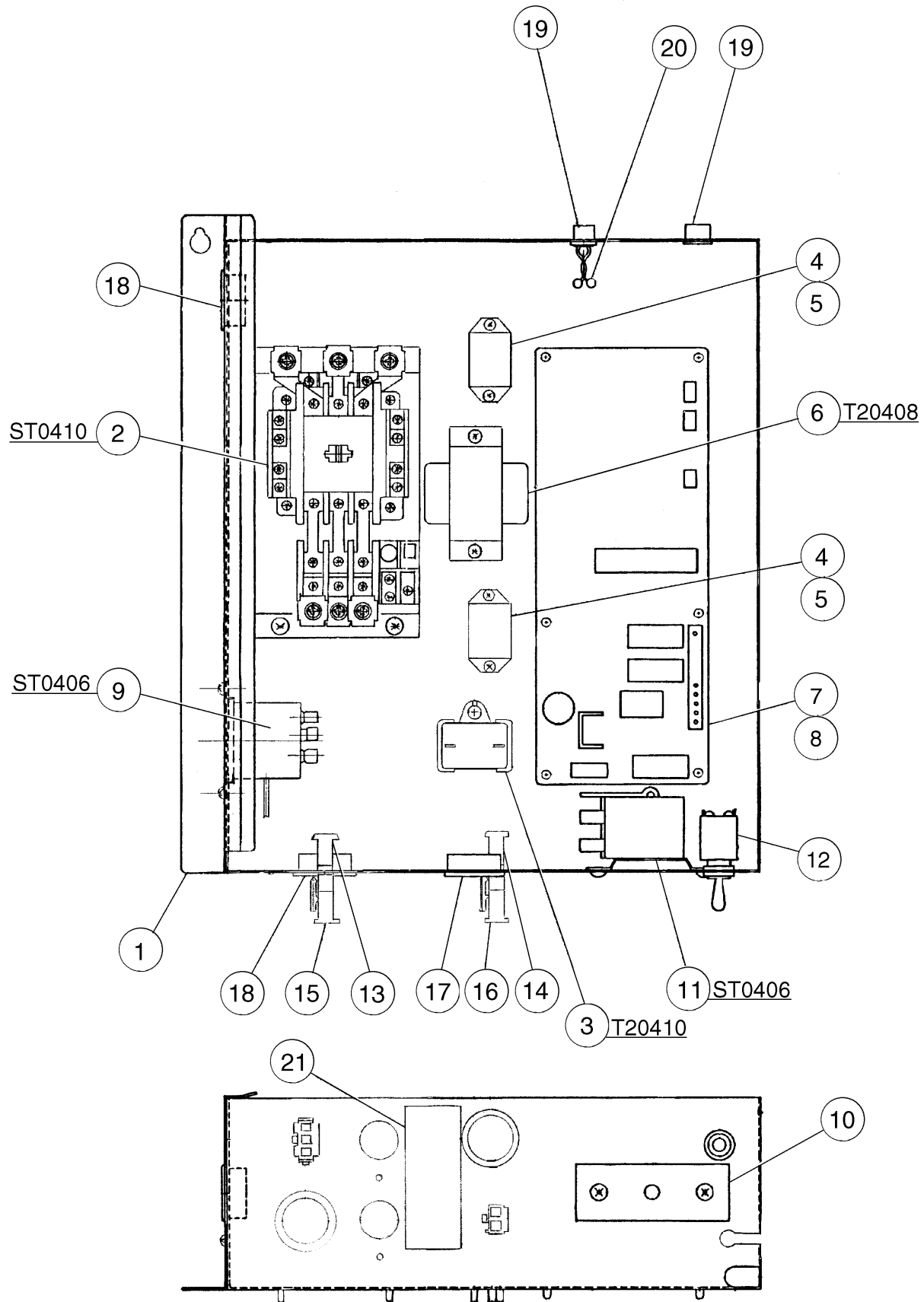

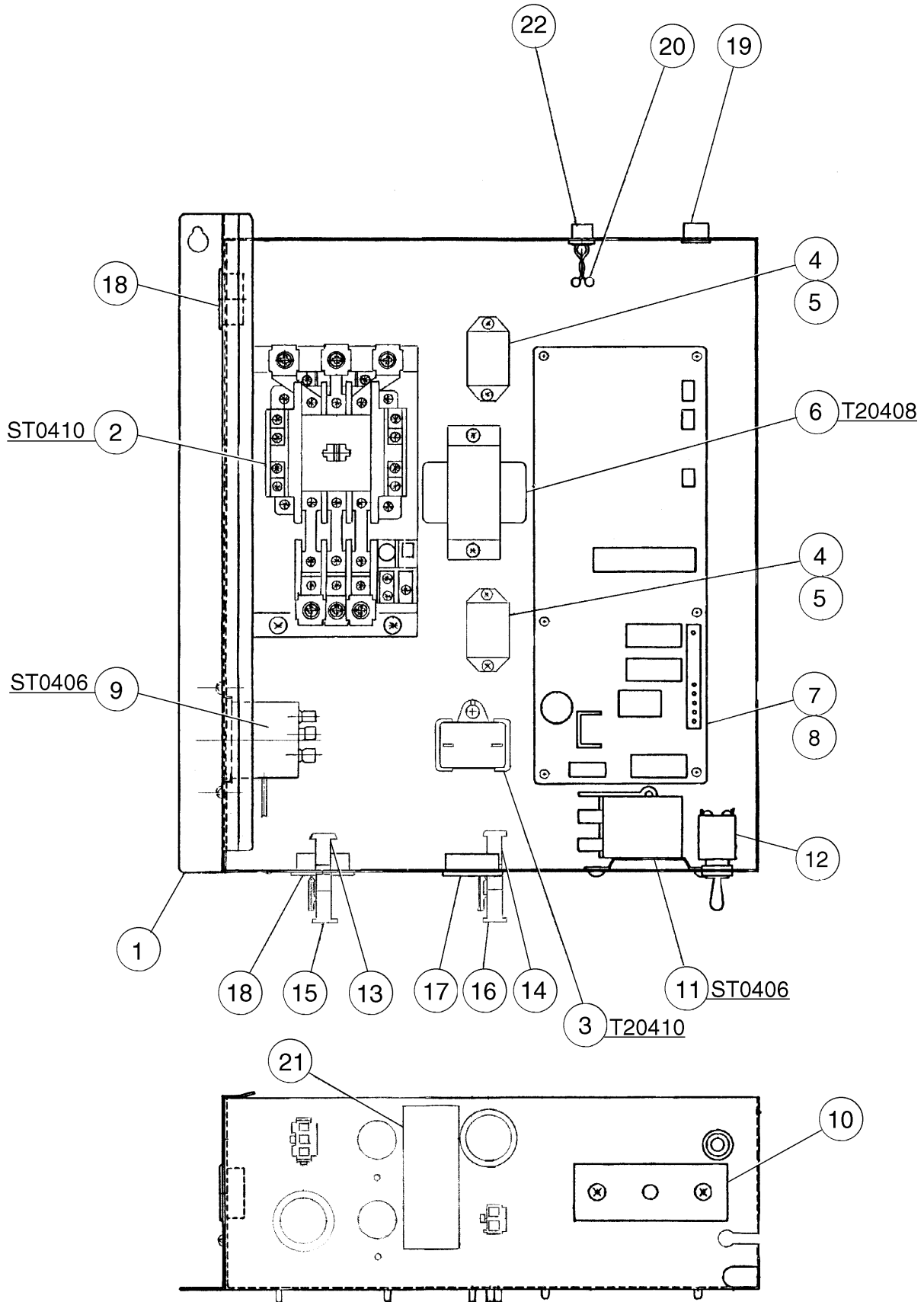

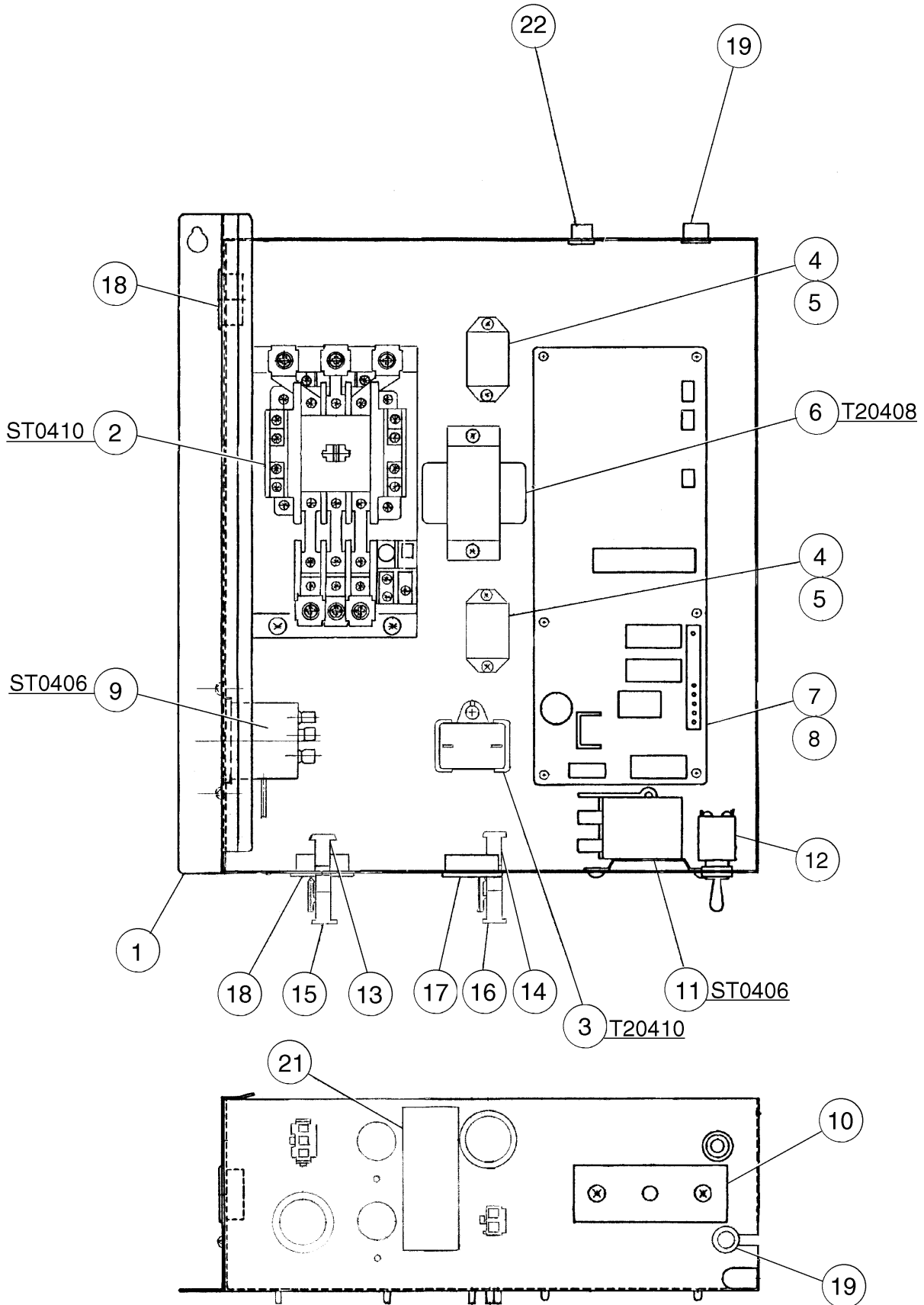

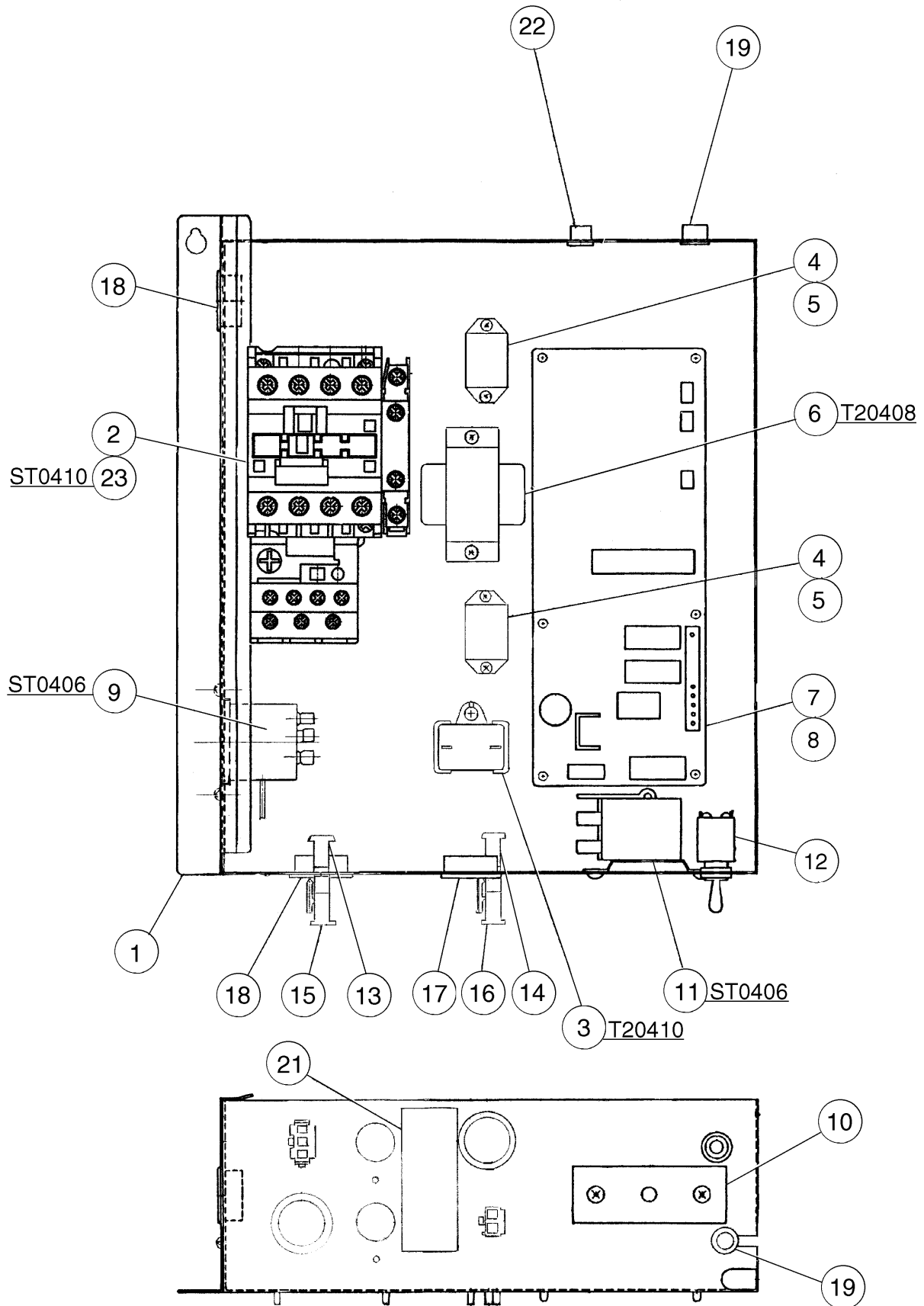

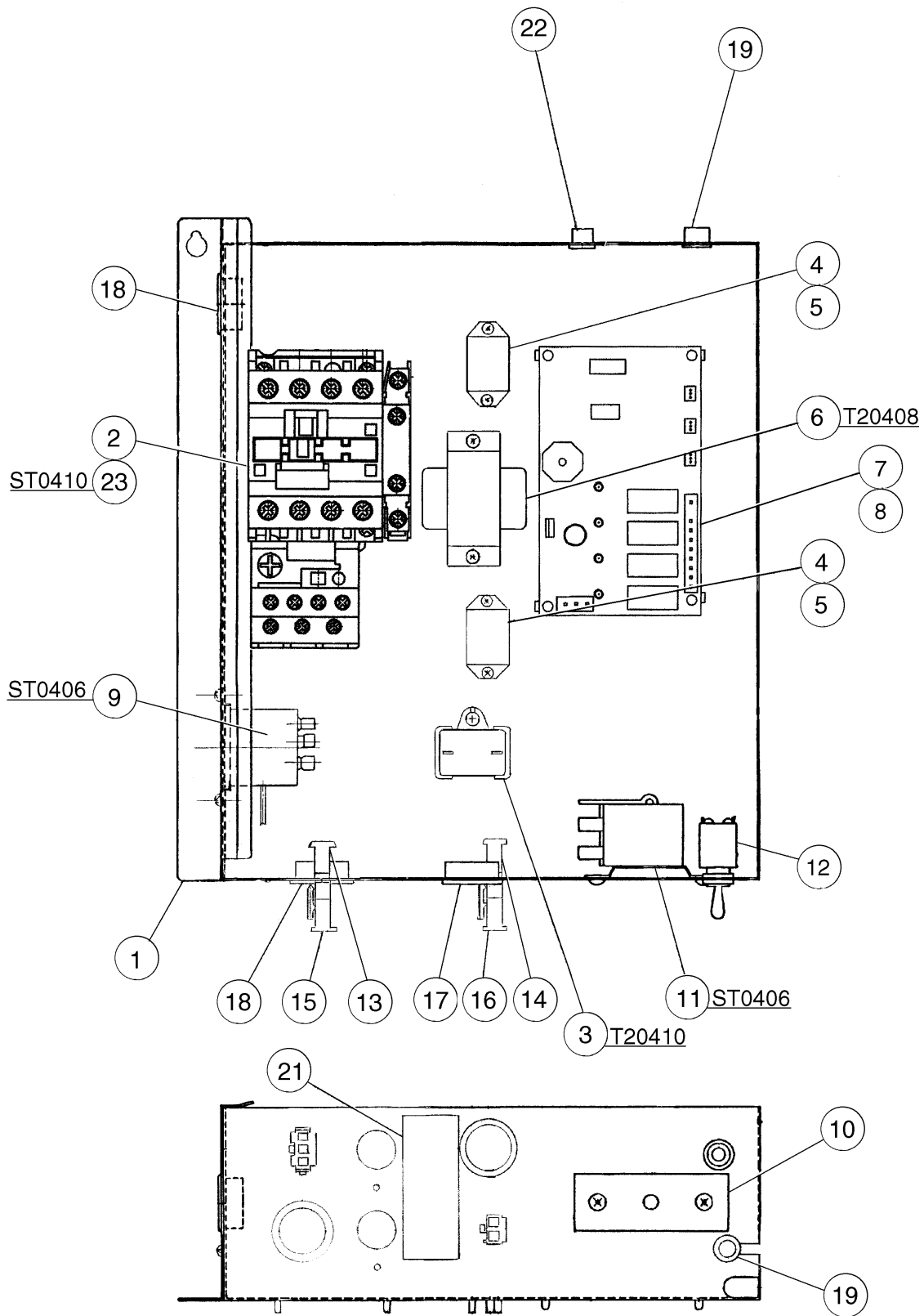

MODEL: KM-2400SRB3 TITLE: D. CONTROL BOX ASSEMBLY														
INDEX NO.	DESCRIPTION	MATERIAL OR MODEL NUMBER	PART NUMBER	REQUIRED NUMBER										
				B-1	B-2	C-0	C-1	D-0	E-0 E-1	F-0 G-0 G-1	H-1	H-2	H-3	J-1
1	CONTROL BOX	GS	215964G01	1	1	x1								
		GS	2A0175G01			o1	1	1	1	1	-			
		GS	2A0175G02								1	1	1	1
2	MAGNETIC CONTACTOR	M-25E	440360-01	1	1	1	1	1	1	1	-			
		-	4A1290-01								1	1	1	1
3	CAPACITOR	SH-SPXU, 15MFD 240V	439705-01	1	1	1	1	1	1	1	1	1	1	1
4	RELAY	LY-2F	406132-07	2	2	2	2	2	2	2	2	2	2	2
5	TAPPING SCREW	3x8	431415-01	4	4	4	4	4	4	4	4	4	4	4
6	TRANSFORMER	BW48-005	3U0135-01	1	1	1	x1							
		260-285H	3A0172-01				o1	1	1	1	1	1	1	1
7	CONTROLLER BOARD	MY9KM910	2U0127-01	1	1	1	1	1	1	1	1	1	-	
		-	2A0836-01										1	x1
		-	2A1410-01											o1
8	BOARD SUPPORT	KGLS-6S	414929-01	6	6	x6								
		CBLS37-M	4A0336-03			o6	6	6	6	6	6	6	4	4
9	THERMOSTAT	A22-1249-00	440377-01	1	1	1	1	1	1	1	1	1	1	1
10	CONTROL LABEL	PES FILM	434934-01	1	1	1	1	1	1	1	1	1	-	
		-	4A1578-01										1	1
11	THERMOSTAT	YTB-3U106	433536-02	1	1	x1								
		-	439678-02			o1	1	1	x1					
		-	4A0738-02						o1	x1				
		-	4A0824-02							o1	1	1	1	1
12	TOGGLE SWITCH	8966K84	443119-01	1	1	1	1	1	1	1	1	1	1	1
13	3P PLUG HOUSING	3191-03P	412832-06	1	1	1	1	1	1	1	1	1	1	1
14	2P PLUG HOUSING	3191-02P	412832-07	1	1	1	1	1	1	1	1	1	1	1
15	3P RECEPTACLE HOUSING	3191-03R1	412831-06	1	1	1	1	1	1	1	1	1	1	1
16	2P RECEPTACLE HOUSING	3191-02R1	412831-07	1	1	1	1	1	1	1	1	1	1	1

HA

KM-2400SRB3

E. TRANSFORMER BOX ASSEMBLY

B-1, B-2, C-0, C-1,
D-0, E-0, E-1, F-0,
G-0, G-1, H-1, H-2,
H-3, J-1

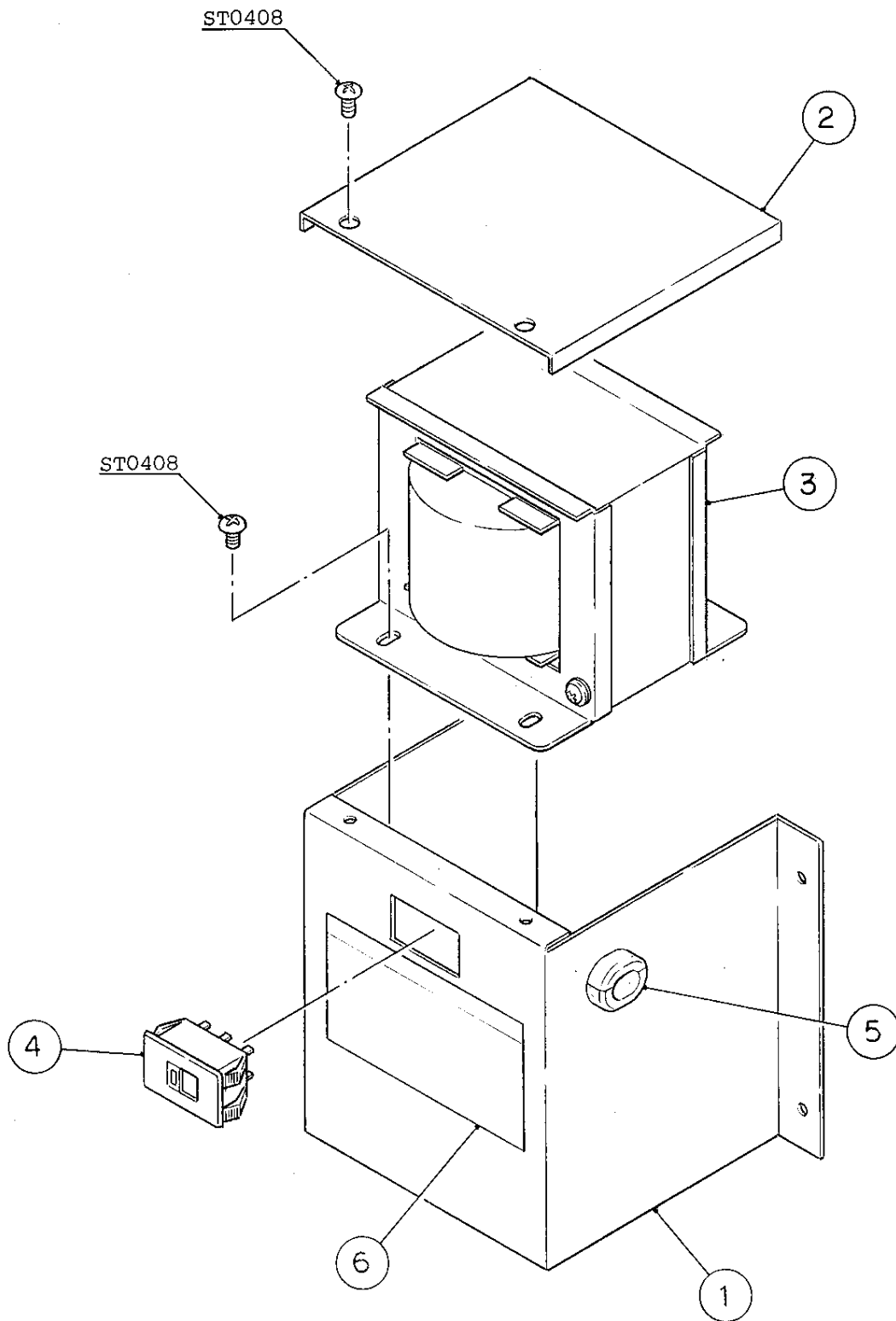

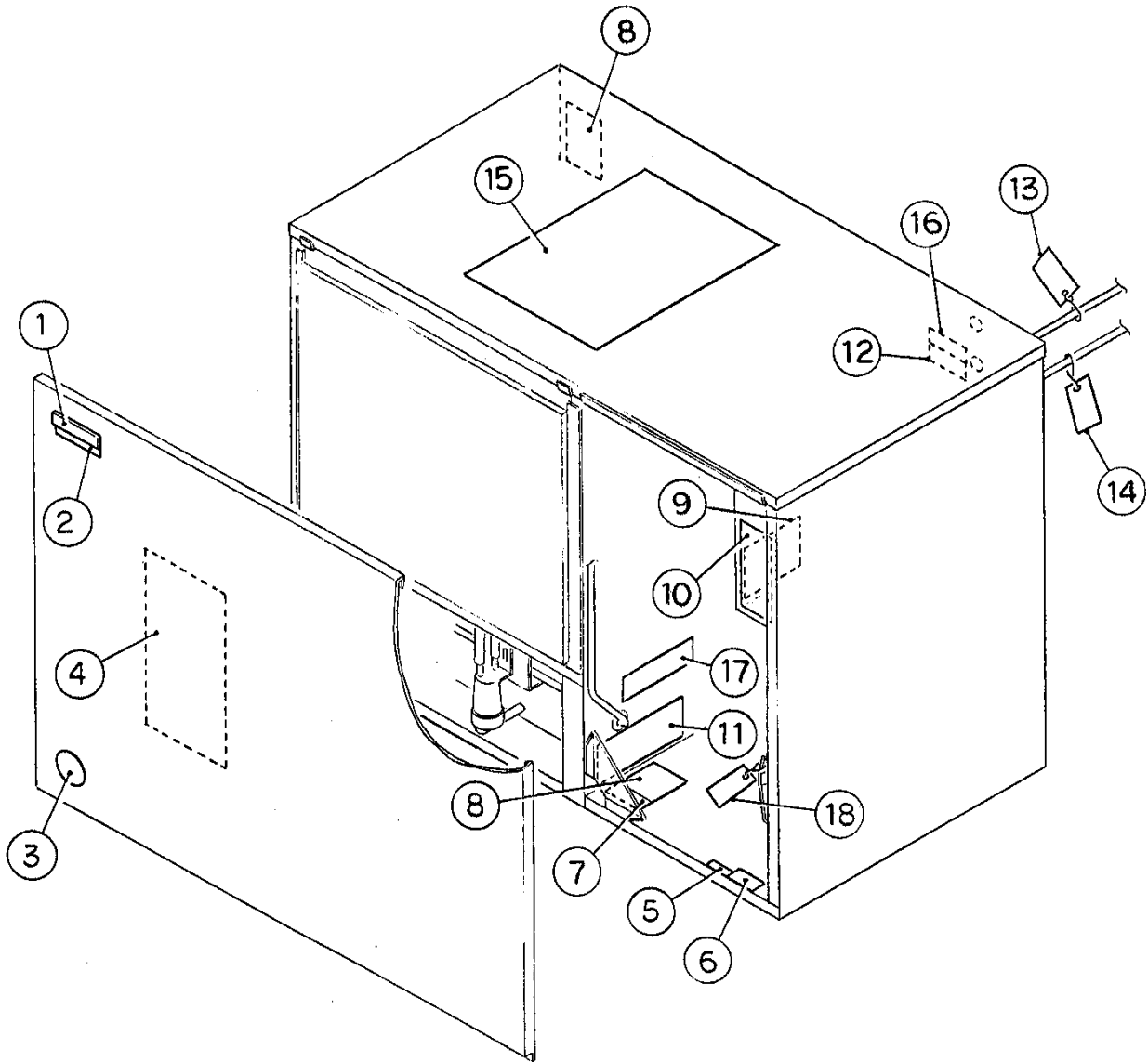

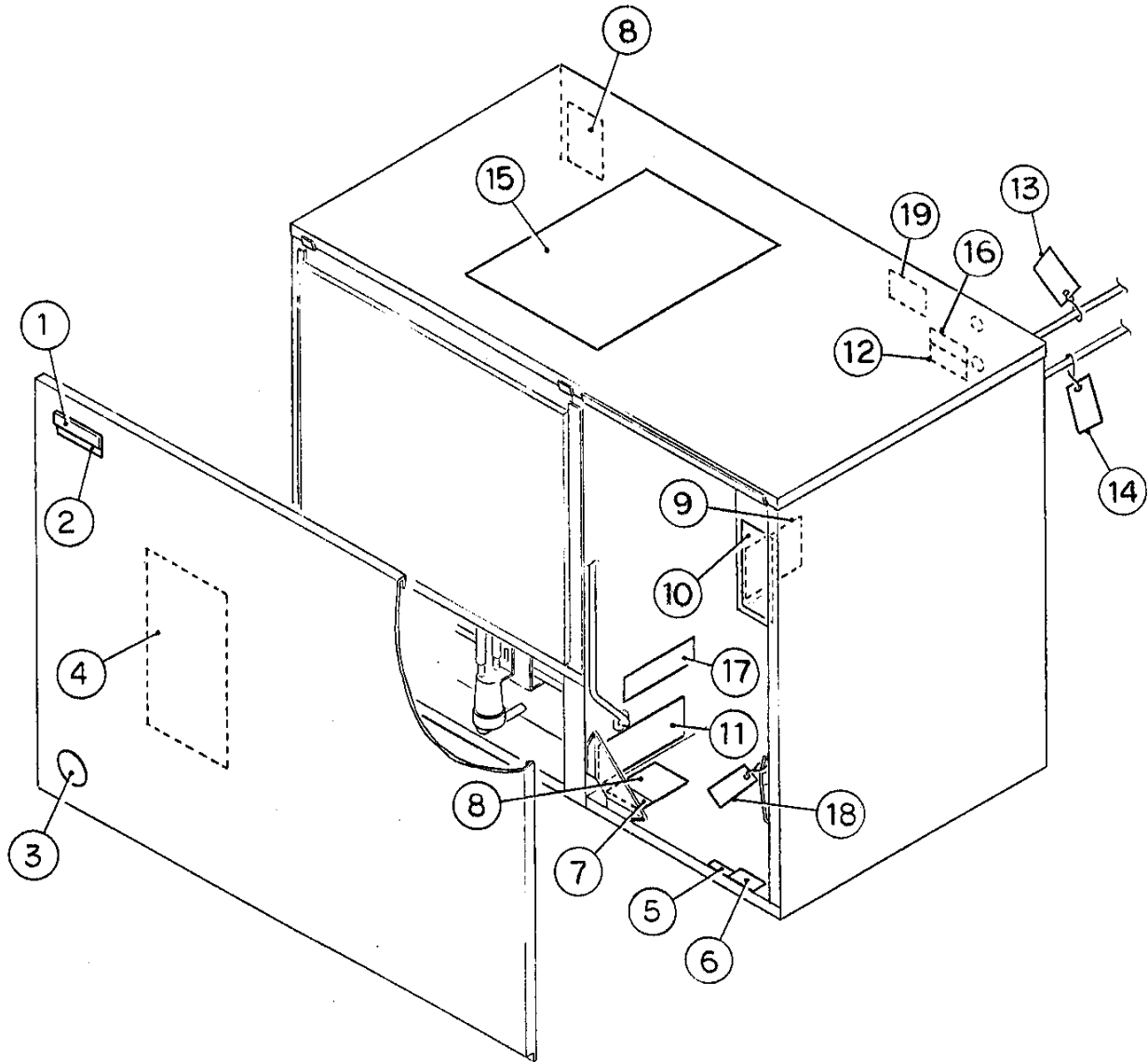

HA

KM-2400SRB3

F. LABEL LOCATION

D-0, E-0, E-1, F-0
G-0, G-1, H-1

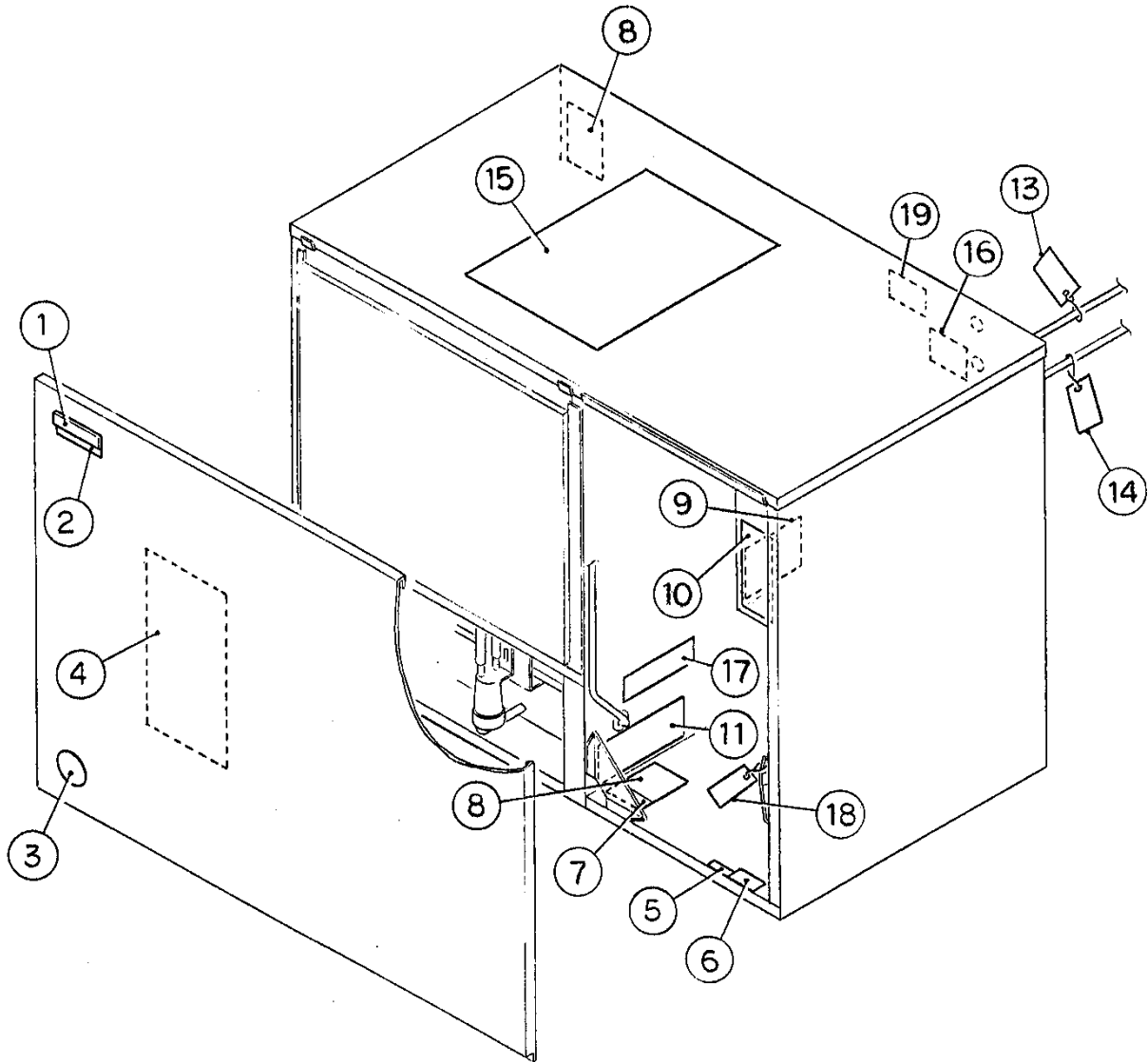

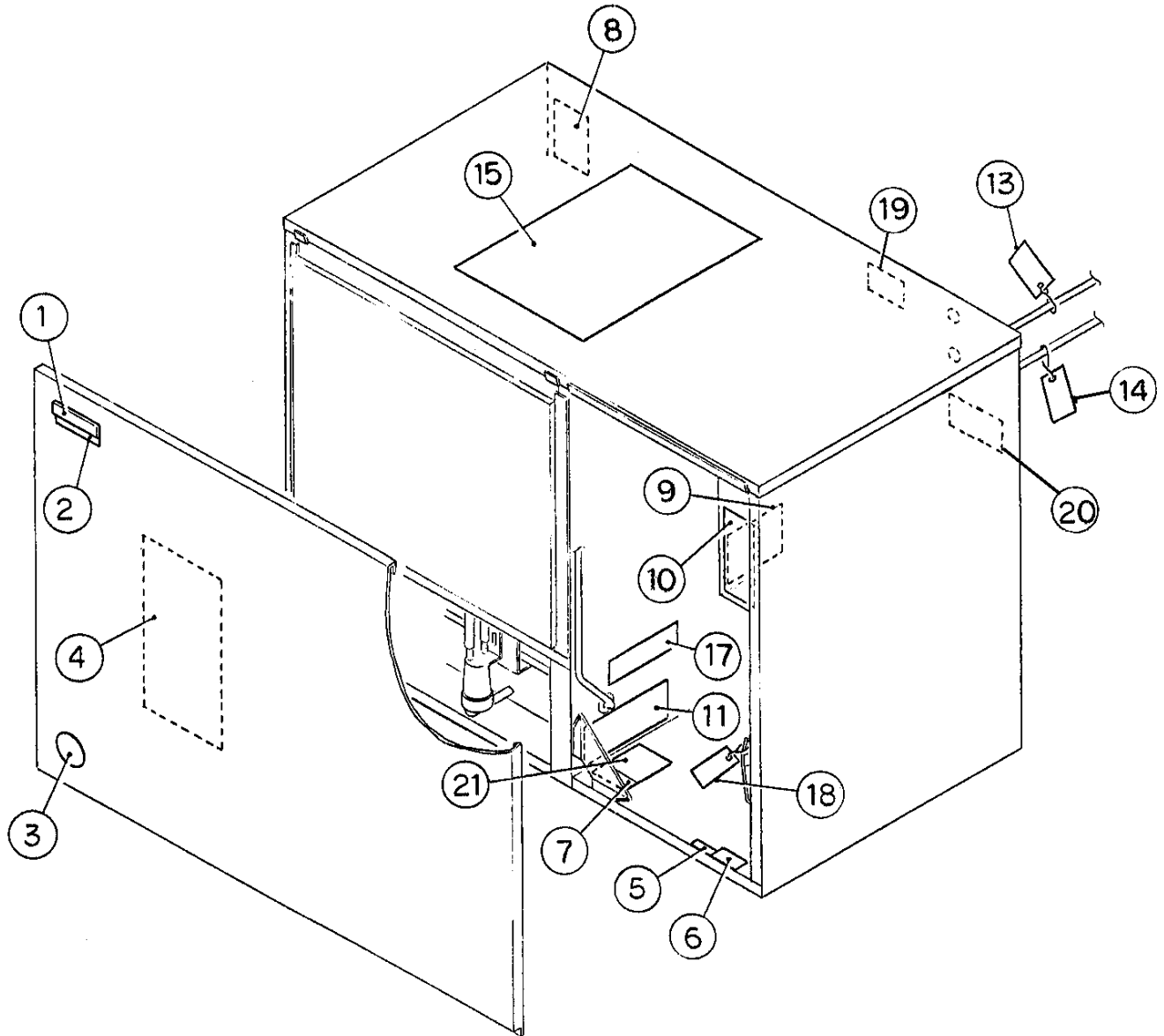

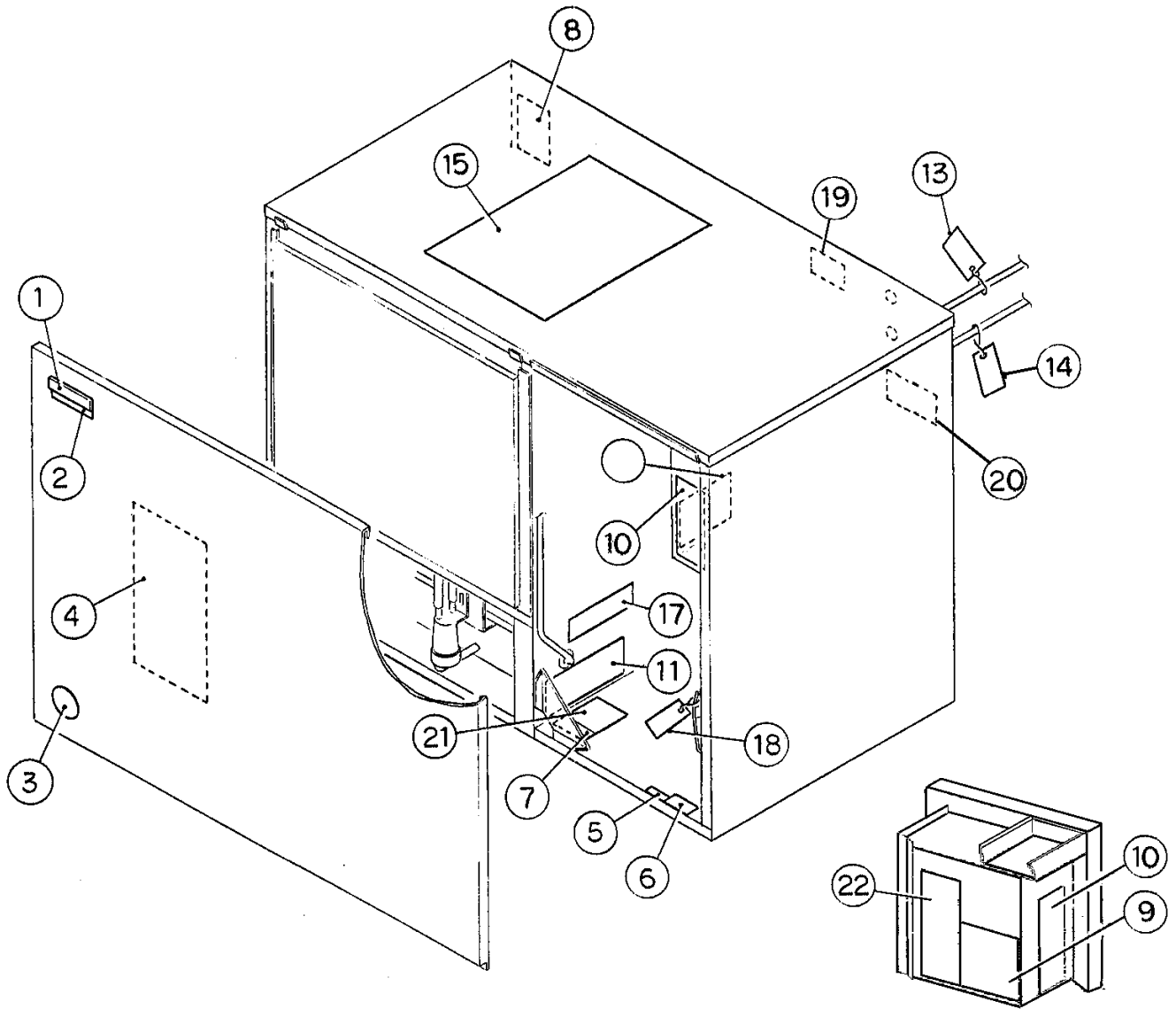

Detail Control Box

MODEL: KM-2400SRB3 TITLE: F. LABEL LOCATION															
INDEX NO.	DESCRIPTION	MATERIAL OR MODEL NUMBER	PART NUMBER	REQUIRED NUMBER											
				B-1	B-2	C-0	C-1	D-0 E-0	E-1	F-0 G-0 G-1	H-1	H-2	H-3	J-1	
1	EMBLEM (L) - HOSHIZAKI	ABS	418634G01	1	1	1	1	1	1	1	x1				
	EMBLEM	PETP FILM	4A0560-01								o1	1	1	1	1
2	MODEL NUMBER LABEL	PES FILM	436041-32	1	1	1	1	1	1	1	1	1	1	1	1
3	LABEL - PENGUIN (R)	PETP FILM	410994-01	1	1	1	1	1	1	1	x1				
		PETP FILM	4A0526-01								o1	1	1	1	1
4	MAINTENANCE LABEL	PVC FILM	326275-01	1	1	1	1	1	1	1	1	1	1	1	1
5	WARNING LABEL - DANGER	PVC FILM	425322-01	1	1	1	1	1	1	1	1	1	x1		
	CAUTION LABEL (K)	-	439150-01										o1	1	1
6	LABEL - R22	PES FILM	440362-01	1	1	1	1	1	1	1	1	1	1	1	1
7	LABEL - CHARGE	PES FILM	326685-01	1	1	1	1	1	1	1	1	1	1	1	1
8	NAMEPLATE	PES FILM	440363-01	2	2	2	-								
		PES FILM	4A0701-01				2	2	2	2	2	2	1	1	1
9	WIRING LABEL	PVC FILM	326686-02	1	1	1	1	1	1	1	-				
		PVC FILM	3A0877-01									1	1	1	1
10	MANUAL LABEL	PVC FILM	324476-01	1	1	1	1	1	1	1	1	1	1	1	1
11	MANUAL LABEL - BIN CONTROL	PVC FILM	326255-01	1	1	1	1	1	1	1	1	1	1	1	1
12	CAUTION LABEL	PVC FILM	441890-01	1	1	1	1	-							
13	TAG - WARNING: ELECTRICAL CONNECT	PAPER	438479-01	1	1	1	1	1	1	1	1	1	1	1	1
14	TAG - FAN MOTOR LEADS	PAPER	420742-01	1	1	1	1	-							
		PAPER	4A0647-01					1	1	1	1	x1			
		PAPER	4A1494-01										o1	1	1
15	INSTRUCTION SHEET	PAPER	214266-01	1	1	1	1	1	x1						
		PAPER	218058-01							o1	x1				
		PAPER	2A0707-01								o1	1	1	1	1
16	LABEL CONNECTION	PVC FILM	440364-01	1	1	1	1	1	1	1	1	-			
17	OPERATION LABEL - VALVE	PVC FILM	439541-01	1	1	1	1	1	1	1	1				

HA

MODEL: KM-2400SRB3 TITLE: F. LABEL LOCATION														
INDEX NO.	DESCRIPTION	MATERIAL OR MODEL NUMBER	PART NUMBER	REQUIRED NUMBER										
				B-1	B-2	C-0	C-1	D-0 E-0	E-1	F-0 G-0 G-1	H-1	H-2	H-3	J-1
18	TAG - CAUTION	PAPER	441544-01	1	1	1	1	1	1	1	1	1	1	
19	INSTRUCTION LABEL	PVC FILM	444575-01			1	1	1	1	1	1	1	1	
20	CAUTION – REMOTE LABEL	-	4A1422-01									1	1	
21	RATING LABEL	-	4A1620-01									1	1	
22	LABEL – CONTROL BOARD	-	3A0998-01										1	
		-	3A1272-01										1	

HA

KM-2400SRB3

G. EVAPORATOR

B-1, B-2, C-0, C-1, D-0,
E-0, E-1, F-0, G-0, G-1,
H-1, H-2, H-3, J-1

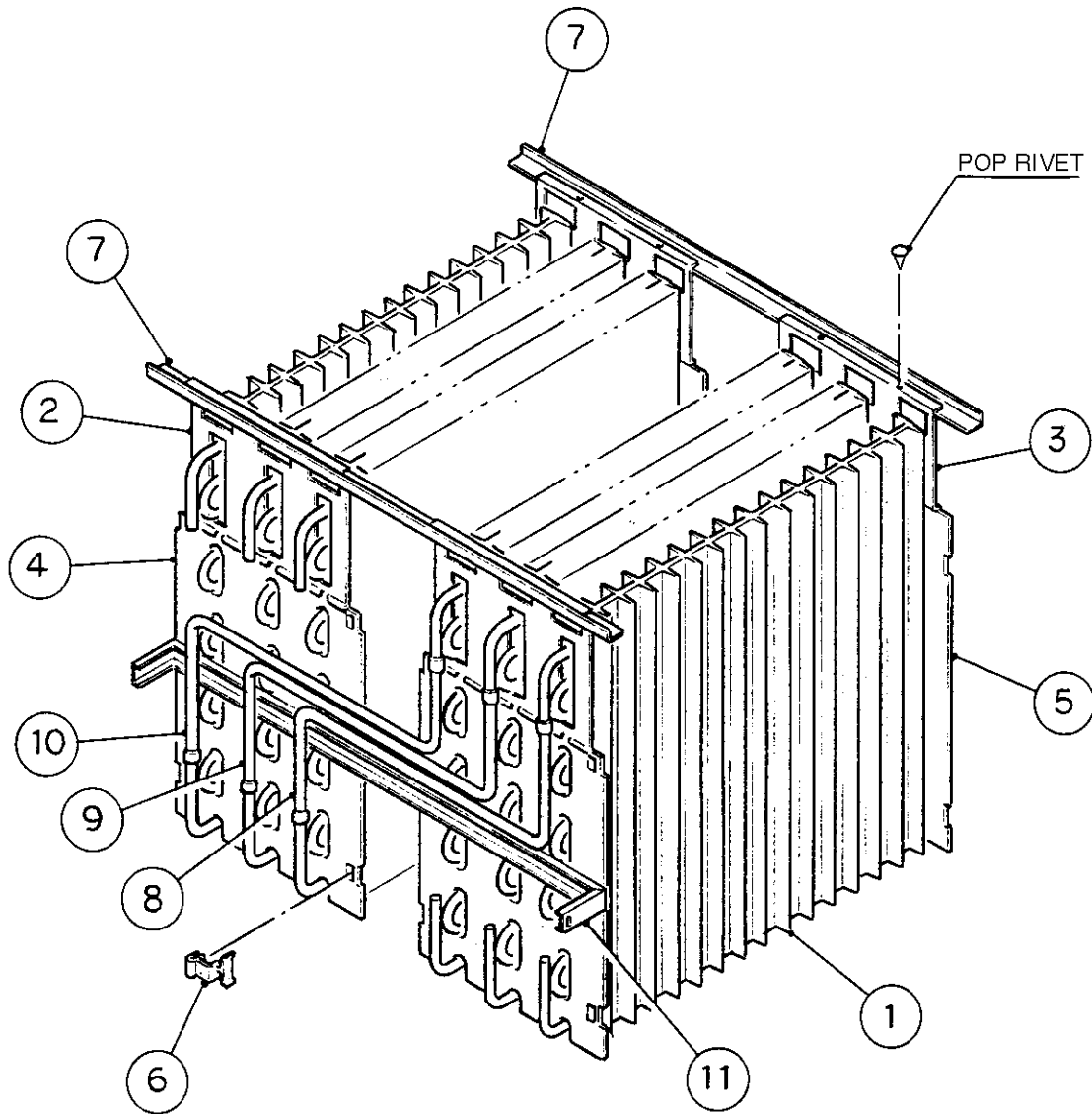

MODEL: KM-2400SRB3 TITLE: G. EVAPORATOR														
INDEX NO.	DESCRIPTION	MATERIAL OR MODEL NUMBER	PART NUMBER	REQUIRED NUMBER										
				B-1	B-2	C-0	C-1	D-0 E-0	E-1	F-0 G-0 G-1	H-1	H-2	H-3	J-1
1	EVAPORATOR	(S-0641)	103317G02	6	6	6	6	6	6	6	6	6	6	6
2	EVAP. BRACKET (A)	SS	323690-01	2	2	2	2	2	2	2	2	2	2	2
3	EVAP. BRACKET (B)	SS	323691-01	2	2	2	2	2	2	2	2	2	2	2
4	END PLATE (A)	ABS	325859-01	2	2	2	2	2	2	2	2	2	2	2
5	END PLATE (B)	ABS	325860-01	2	2	2	2	2	2	2	2	2	2	2
6	HOOK	PE	324152-01	8	8	8	8	8	x8					
		PP	324152-01						o8	8	8	8	8	8
7	EVAP. BRACKET	GS	436582-01	2	2	2	2	2	2	2	2	2	2	2
8	COPPER TUBE (A) - EVAP.	COPPER	326709G01	1	1	1	1	1	1	1	1	1	1	1
9	COPPER TUBE (B) - EVAP.	COPPER	326710G01	1	1	1	1	1	1	1	1	1	1	1
10	COPPER TUBE (C) - EVAP.	COPPER	326711G01	1	1	1	1	1	1	1	1	1	1	1
11	EVAP. BRACKET (C)	SS	325868-01	1	1	1	1	1	1	1	1	1	1	1

HA

KM-2400SRB3

H. PUMP MOTOR ASSEMBLY

B-1, B-2, C-0, C-1, D-0,
E-0, E-1, F-0, G-0, G-1,
H-1, H-2, H-3, J-1

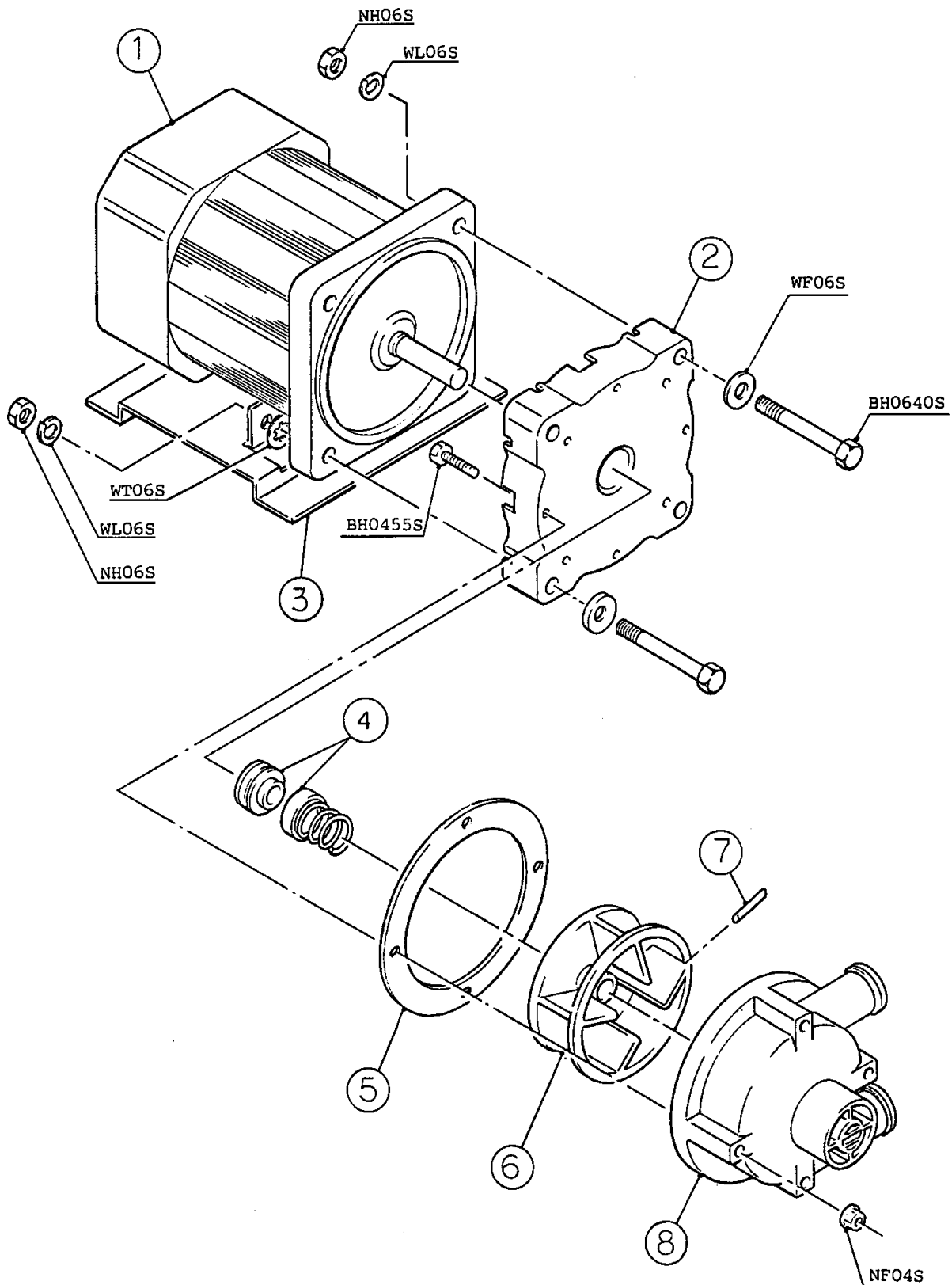

MODEL: KM-2400SRB3 TITLE: H. PUMP MOTOR ASSEMBLY														
INDEX NO.	DESCRIPTION	MATERIAL OR MODEL NUMBER	PART NUMBER	REQUIRED NUMBER										
				B-1	B-2	C-0	C-1	D-0 E-0	E-1	F-0 G-0 G-1	H-1	H-2	H-3	J-1
1	PUMP MOTOR	M91A60SP201	2U0106-01	1	1	1	1	1	1	1	1	1	1	1
2	PUMP FLANGE	PC	215662-01	1	1	1	1	1	1	1	1	1	1	1
3	PUMP MOTOR BRACKET	SS	323904-01	1	1	1	1	1	1	1	1	1	1	1
4	MECHANICAL SEAL	H5-PN, 8MM	428545-01	1	1	1	1	1	1	1	1	1	1	1
5	PACKING	EPDM	428547-01	1	1	1	1	1	1	1	1	1	1	1
6	IMPELLER	ABS	436584-01	1	1	1	1	1	1	1	1	1	1	1
7	PIN	SS	414102-01	1	1	1	1	1	1	1	1	1	1	1
8	PUMP HOUSING	ABS	213687-01	1	1	1	1	1	1	1	1	1	1	1

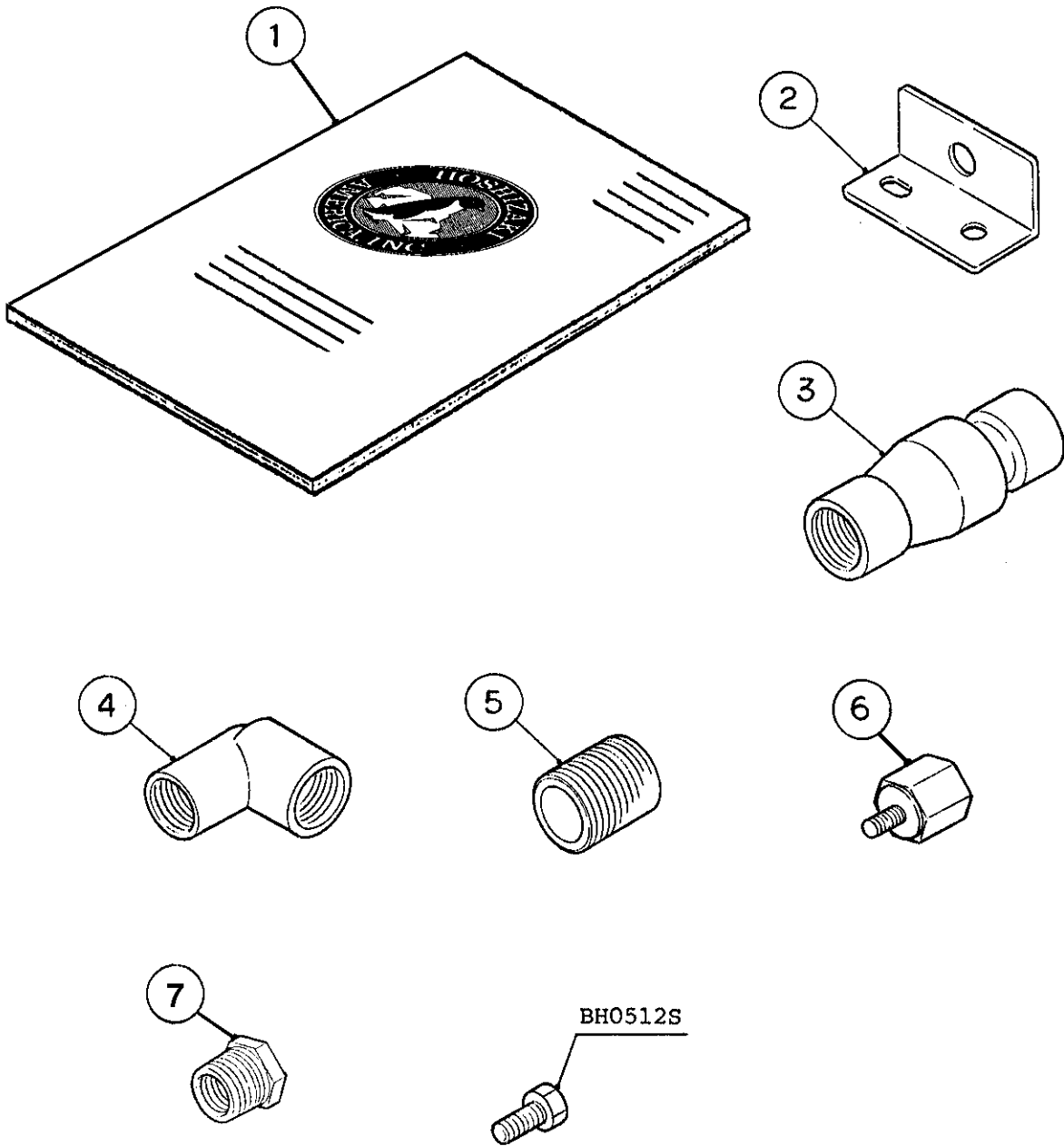

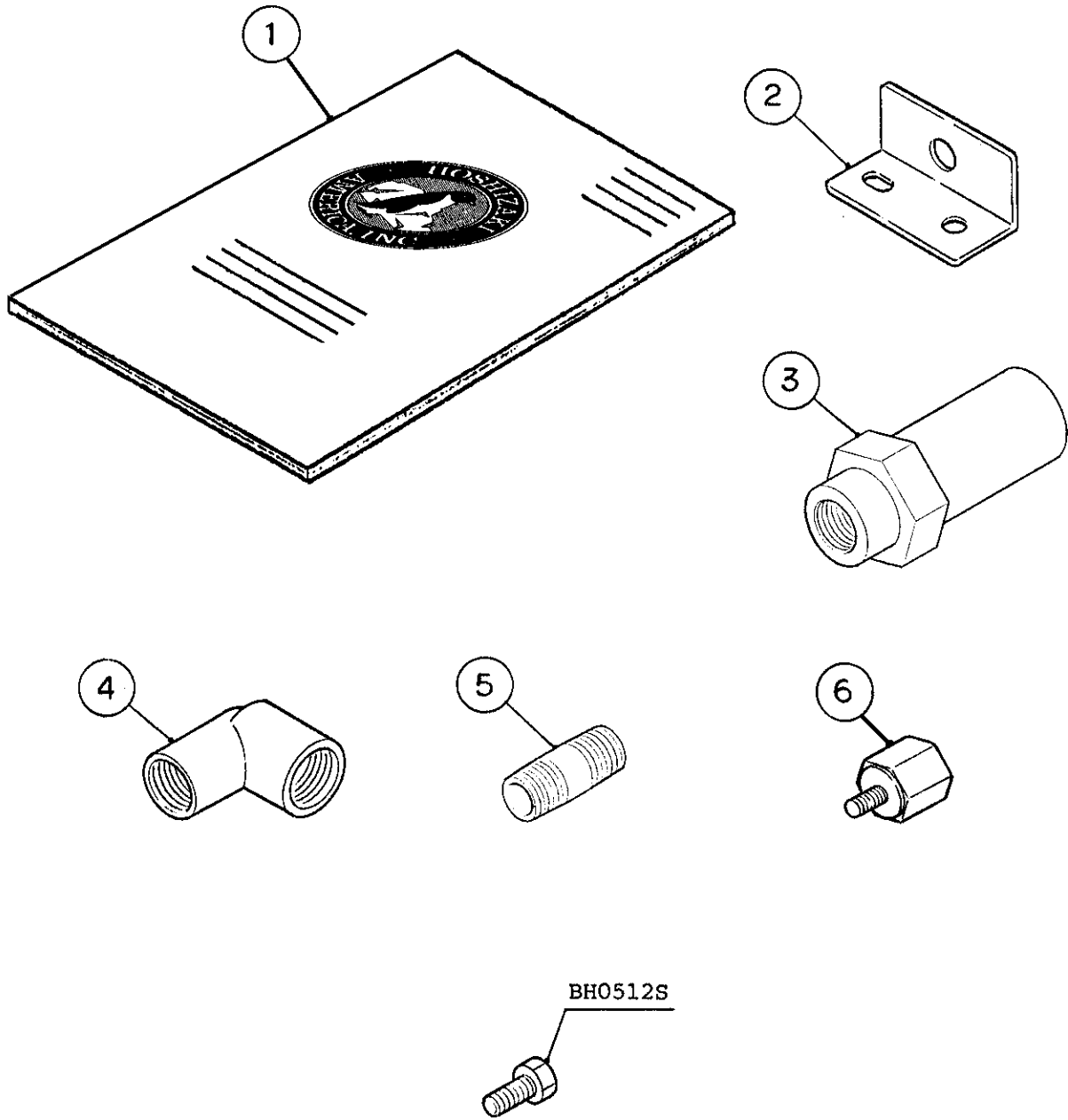

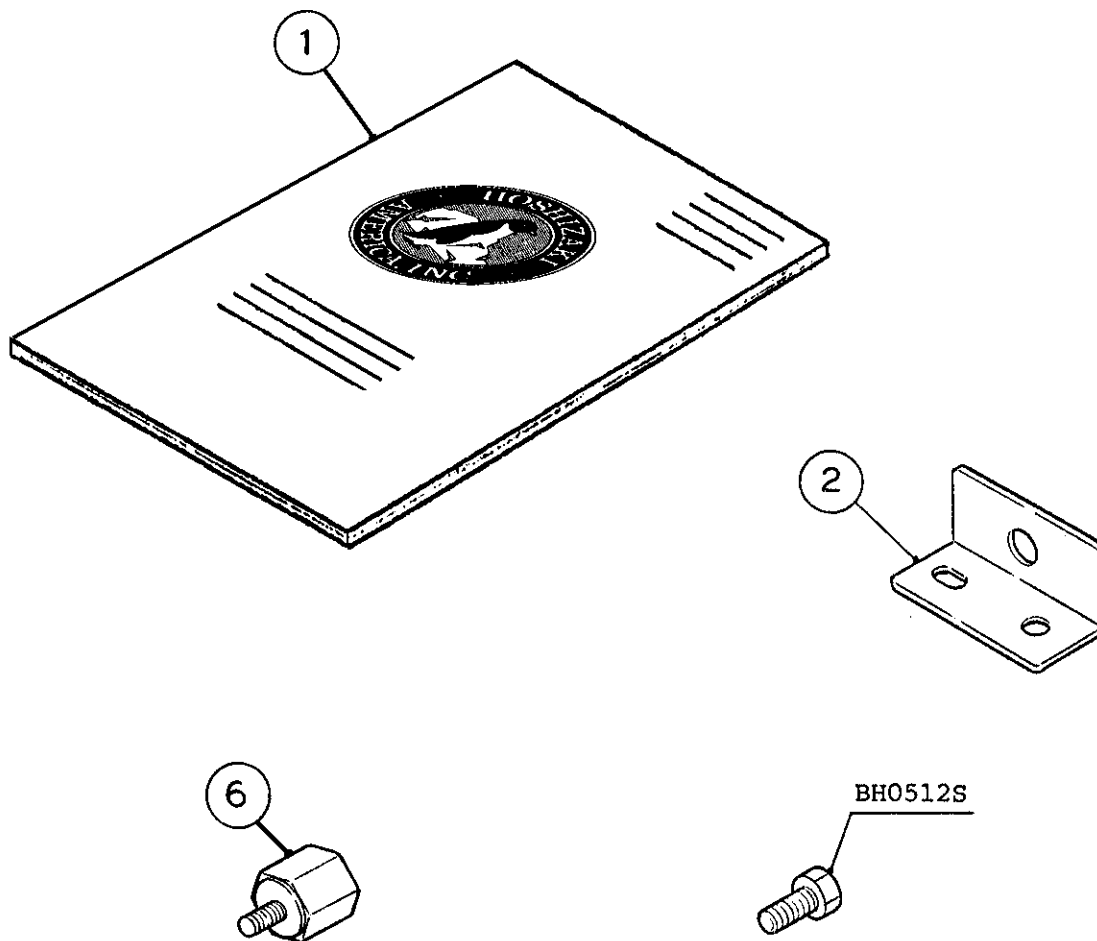

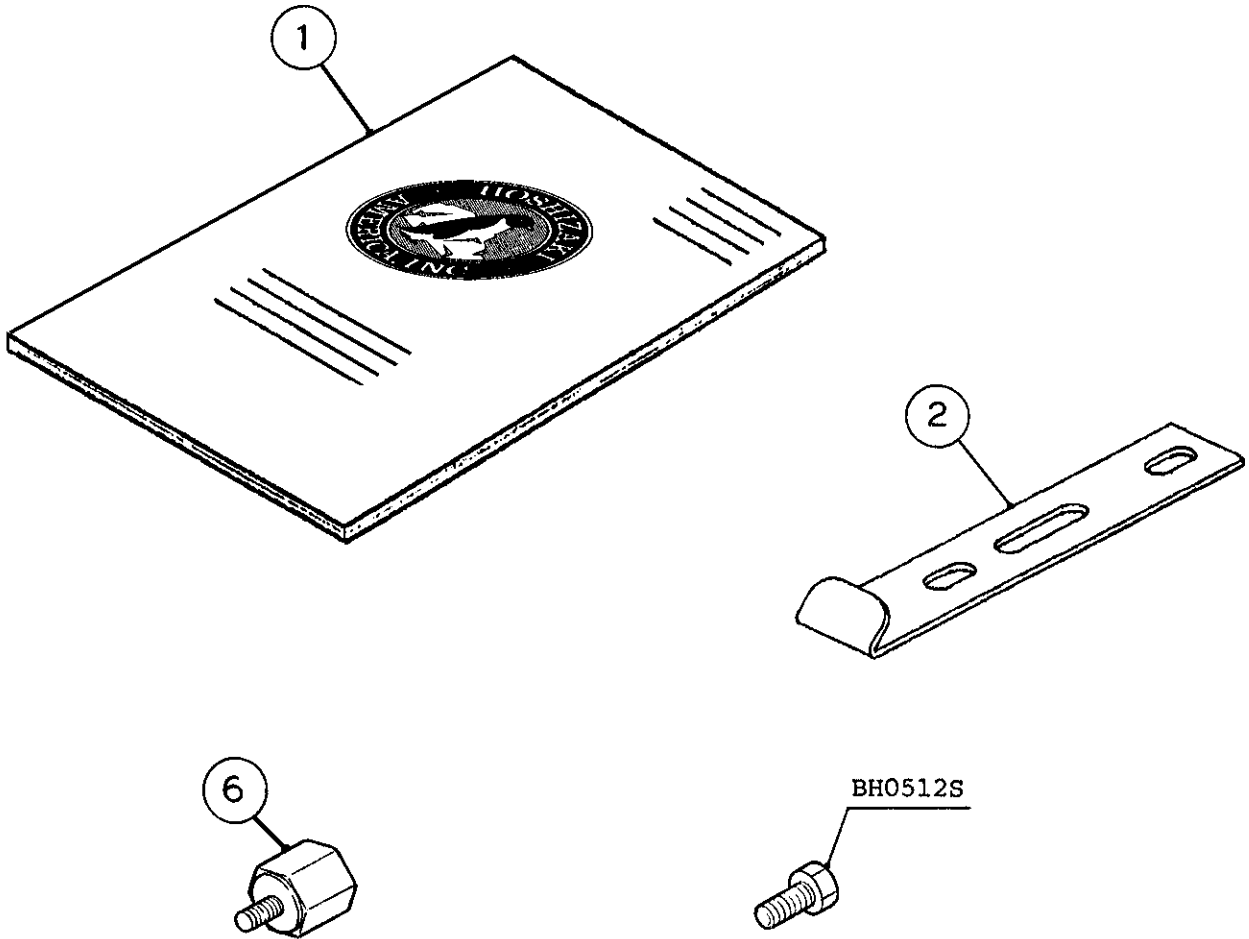

HA

KM-2400SRB3

J. ACCESSORIES

F-0, G-0, G-1, H-1, H-2, H-3, J-1

