



Reliability is a
beautiful thing™

HOSHIZAKI®

MODULAR CRESCENT CUBER

MODELS

KMD-700MAH

KMD-700MWH

KMD-700MRH

PARTS LIST



ITEM #: 71221
ISSUED: MAY 29, 2003
REVISED: JUNE 30, 2003

KMD-700MAH N-0 MAY, 2003

KMD-700MWH N-0 MAY, 2003

KMD-700MRH N-0 MAY, 2003

MATERIAL ABBREVIATIONS

ALUMINUM

AL = Aluminum

COPPER

CU = Copper

PLASTIC

ABS = Acrylonitrile -butadiene - styrene
 AC = Polyacetal
 EVA = Ethylene vinyl acetate
 PA = Polyamide = Nylon
 PC = Polycarbonate
 PE = Polyethylene
 PES = Polyester
 PETP = Polyethylene terephthalate = Tetlon
 PP = Polypropylene
 PS = Polystyrene
 PTFE = Polytetrafluoroethylene = Teflon
 PUR = Polyurethane
 PVC = Polyvinyl chloride

RUBBER

VN = Vinyl Nitrile
 EPDM = EP rubber
 NBR = Nitrile butadiene rubber
 NR = Natural rubber
 NP = Neoprene
 SI.R = Silicone rubber
 SY.R = Synthetic rubber
 EPH = Epichlorohydrin

STEEL

G.S = Galvanized steel
 S.S = Stainless steel
 PS = Plated steel
 PAS = Primed steel

AUXILIARY CODE

Ex.1

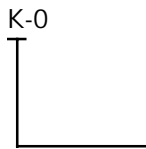

placed

"K" is the tenth in alphabetical order with "I" skipped. So, "K" indicates "2000".

(Note) - = Part deleted.

x = Part deleted and re-

placed by "o" (interchangeable) part.

Ex.2

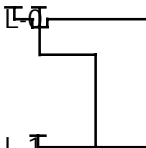

"L" is the next in alphabetical order. So, "L" indicates "2001".

o = New part for "x" in the same auxiliary code.

Ex.3

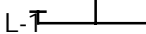

Each time a part is changed non-interchangeably in a year, this number advances.

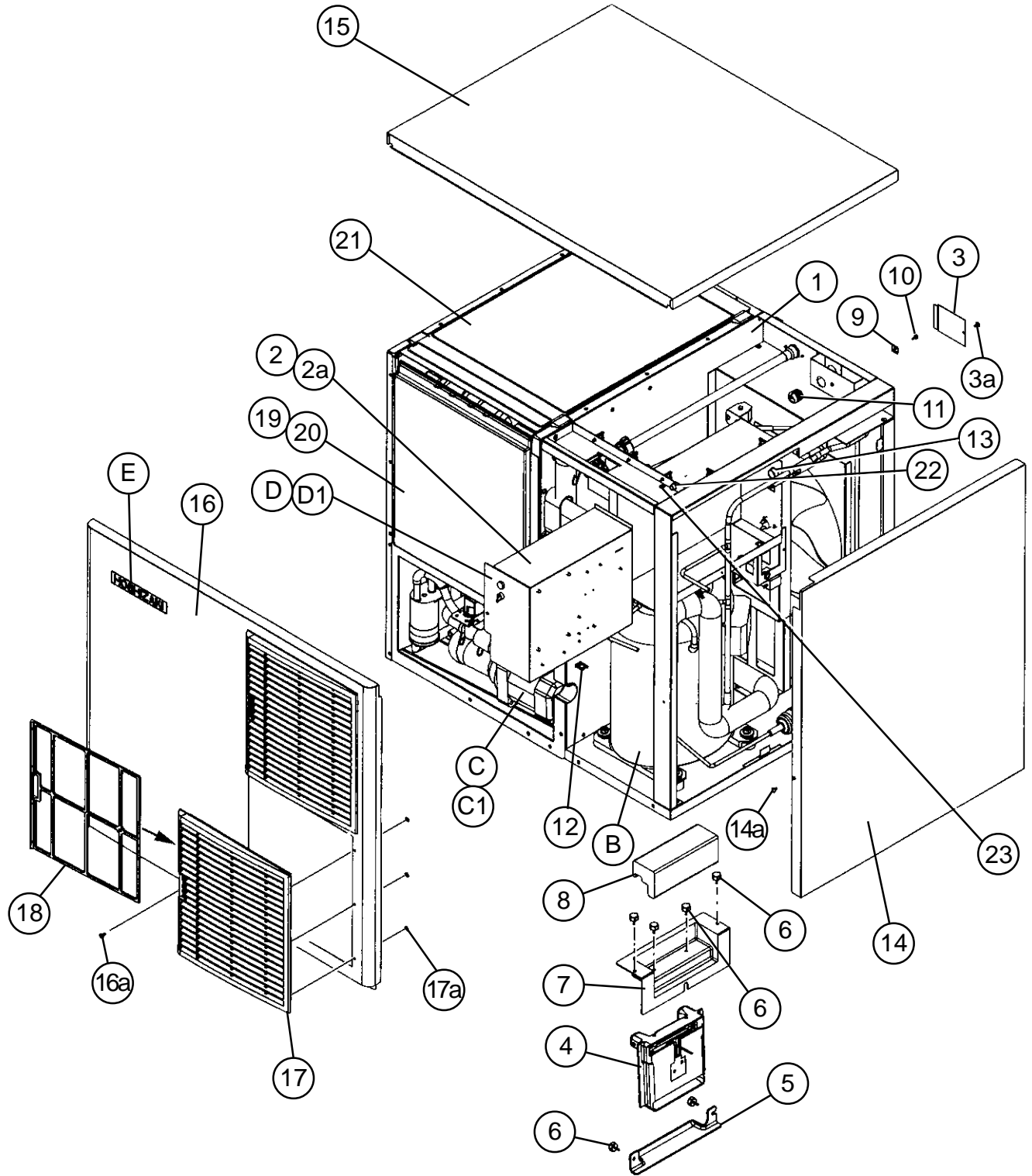

HA

MODEL: KMD-700MAH TITLE: A. ICE CUBER ASSEMBLY								
INDEX NO.	DESCRIPTION	MATERIAL OR MODEL NUMBER	PART NUMBER	REQUIRED NUMBER				
				N-0				
B	REFRIGERATION CIRCUIT	-	1A0799A01	1				
C	WATER CIRCUIT	-	1A0800A01	1				
C1	TRUSS HEAD SCREW	4X8, SS	7C32-0408	2				
D	CONTROL BOX ASSEMBLY	-	2A2818A01	1				
D1	T2 SCREW	4X8	7P31-0408	1				
E	LABEL LOCATION	-	2A2819A01	1				
1	EVAPORATOR CASE	-	1A0790G01	1				
2	CONTROL BOX COVER	GS	3A2687G01	1				
2a	T2 SCREW	4X8	7P31-0408	3				
3	JUNCTION BOX COVER	GS	433410-01	1				
3a	T2 SCREW	4X8	7P31-0408	1				
4	BIN CONTROL	-	464574-01	1				
5	SWITCH GUIDE	-	3A2643-01	1				
6	THUMBSCREW	-	415949G10	6				
7	SWITCH COVER	-	3A2642-01	1				
8	INSULATION SWITCH	-	4A3068-01	1				
9	SQUARE WASHER	-	433537-01	1				
10	SCREW – GROUNDING	-	433304-02	1				
11	BUSHING	-	420472-05	1				
12	WIRE SADDLE	-	4A0338-02	9				
13	BUSHING	-	428394-04	2				
14	SIDE PANEL (R)	SS	2A2800G01	1				
14a	TRUSS HEAD SCREW	4X8, SS	7C32-0408	1				
15	TOP PANEL	SS	2A2801-01	1				
16	FRONT PANEL	SS	2A2802-01	1				
16a	TRUSS HEAD SCREW	4X10, SS	7C32-0410	1				

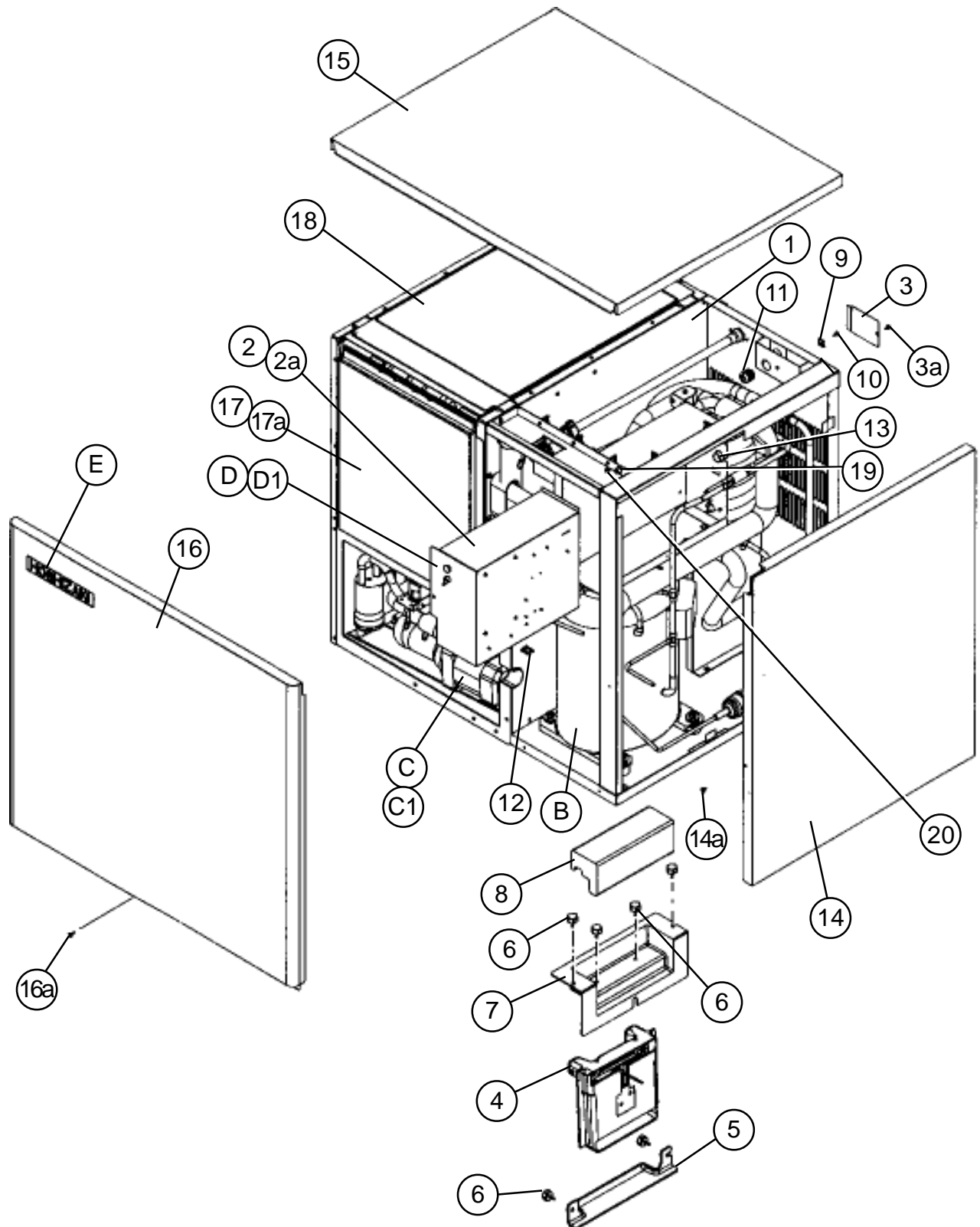

HA

MODEL: KMD-700MWH TITLE: A. ICE CUBER ASSEMBLY										
INDEX NO.	DESCRIPTION	MATERIAL OR MODEL NUMBER	PART NUMBER	REQUIRED NUMBER						
				N-0						
B	REFRIGERATION CIRCUIT	-	1A0815A01	1						
C	WATER CIRCUIT	-	1A0800A01	1						
C1	TRUSS HEAD SCREW	4X8, SS	7C32-0408	2						
D	CONTROL BOX ASSEMBLY	-	2A2818A01	1						
D1	T2 SCREW	4X8	7P31-0408	1						
E	LABEL LOCATION	-	2A2839A01	1						
1	EVAPORATOR CASE	-	1A0790G02	1						
2	CONTROL BOX COVER	GS	3A2687G01	1						
2a	T2 SCREW	4X8	7P31-0408	3						
3	JUNCTION BOX COVER	GS	433410-01	1						
3a	T2 SCREW	4X8	7P31-0408	1						
4	BIN CONTROL	-	464574-01	1						
5	SWITCH GUIDE	-	3A2643-01	1						
6	THUMBSCREW	-	415949G10	6						
7	SWITCH COVER	-	3A2642-01	1						
8	INSULATION SWITCH	-	4A3068-01	1						
9	SQUARE WASHER	-	433537-01	1						
10	SCREW – GROUNDING	-	433304-02	1						
11	BUSHING	-	420472-05	1						
12	WIRE SADDLE	-	4A0338-02	9						
13	BUSHING	-	428394-04	2						
14	SIDE PANEL (R)	SS	2A2800G01	1						
14a	TRUSS HEAD SCREW	4X8, SS	7C32-0408	1						
15	TOP PANEL	SS	2A2801-01	1						
16	FRONT PANEL	SS	2A2802-02	1						
16a	TRUSS HEAD SCREW	4X10, SS	7C32-0410	1						

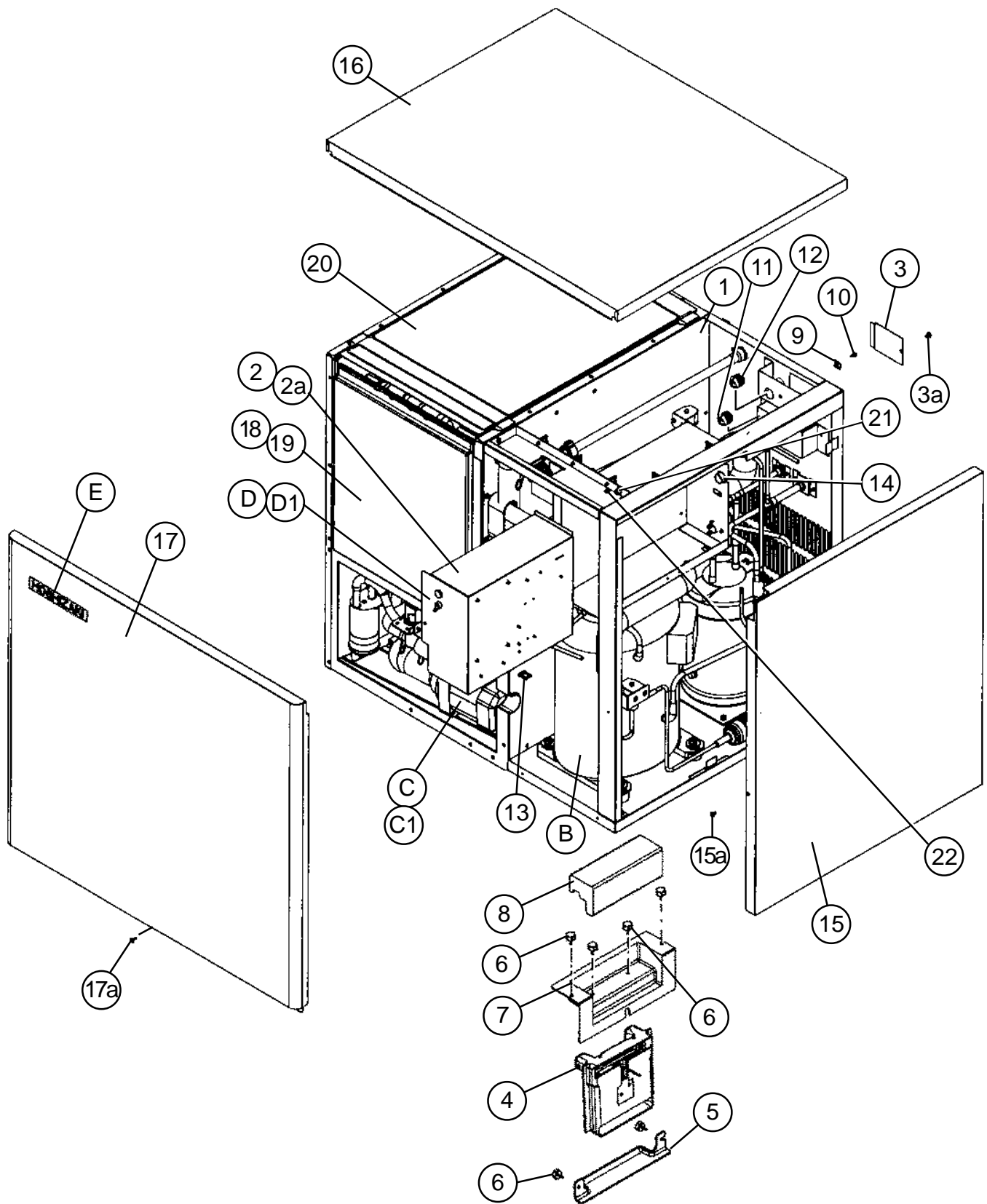

HA

MODEL: KMD-700MRH TITLE: A. ICE CUBER ASSEMBLY										
INDEX NO.	DESCRIPTION	MATERIAL OR MODEL NUMBER	PART NUMBER	REQUIRED NUMBER						
				N-0						
B	REFRIGERATION CIRCUIT	-	1A0801A01	1						
C	WATER CIRCUIT	-	1A0800A01	1						
C1	TRUSS HEAD SCREW	4X8, SS	7C32-0408	2						
D	CONTROL BOX ASSEMBLY	-	2A2818A01	1						
D1	T2 SCREW	4X8	7P31-0408	1						
E	LABEL LOCATION	-	2A2765A01	1						
1	EVAPORATOR CASE	-	1A0790G03	1						
2	CONTROL BOX COVER	GS	3A2687G01	1						
2a	T2 SCREW	4X8	7P31-0408	3						
3	JUNCTION BOX COVER	GS	433410-01	1						
3a	T2 SCREW	4X8	7P31-0408	2						
4	BIN CONTROL	-	464574-01	1						
5	SWITCH GUIDE	-	3A2643-01	1						
6	THUMBSCREW	-	415949G10	6						
7	SWITCH COVER	-	3A2642-01	1						
8	INSULATION SWITCH	-	4A3068-01	1						
9	SQUARE WASHER	-	433537-01	1						
10	SCREW – GROUNDING	-	433304-02	1						
11	BUSHING	-	420472-05	1						
12	BUSHING	-	420472-03	1						
13	WIRE SADDLE	-	4A0338-02	9						
14	BUSHING	-	428394-04	2						
15	SIDE PANEL (R)	SS	2A2800G01	1						
15a	TRUSS HEAD SCREW	4X8, SS	7C32-0408	1						
16	TOP PANEL	SS	2A2801-01	1						
17	FRONT PANEL	SS	2A2802-02	1						
17a	TRUSS HEAD SCREW	4X10, SS	7C32-0410	1						

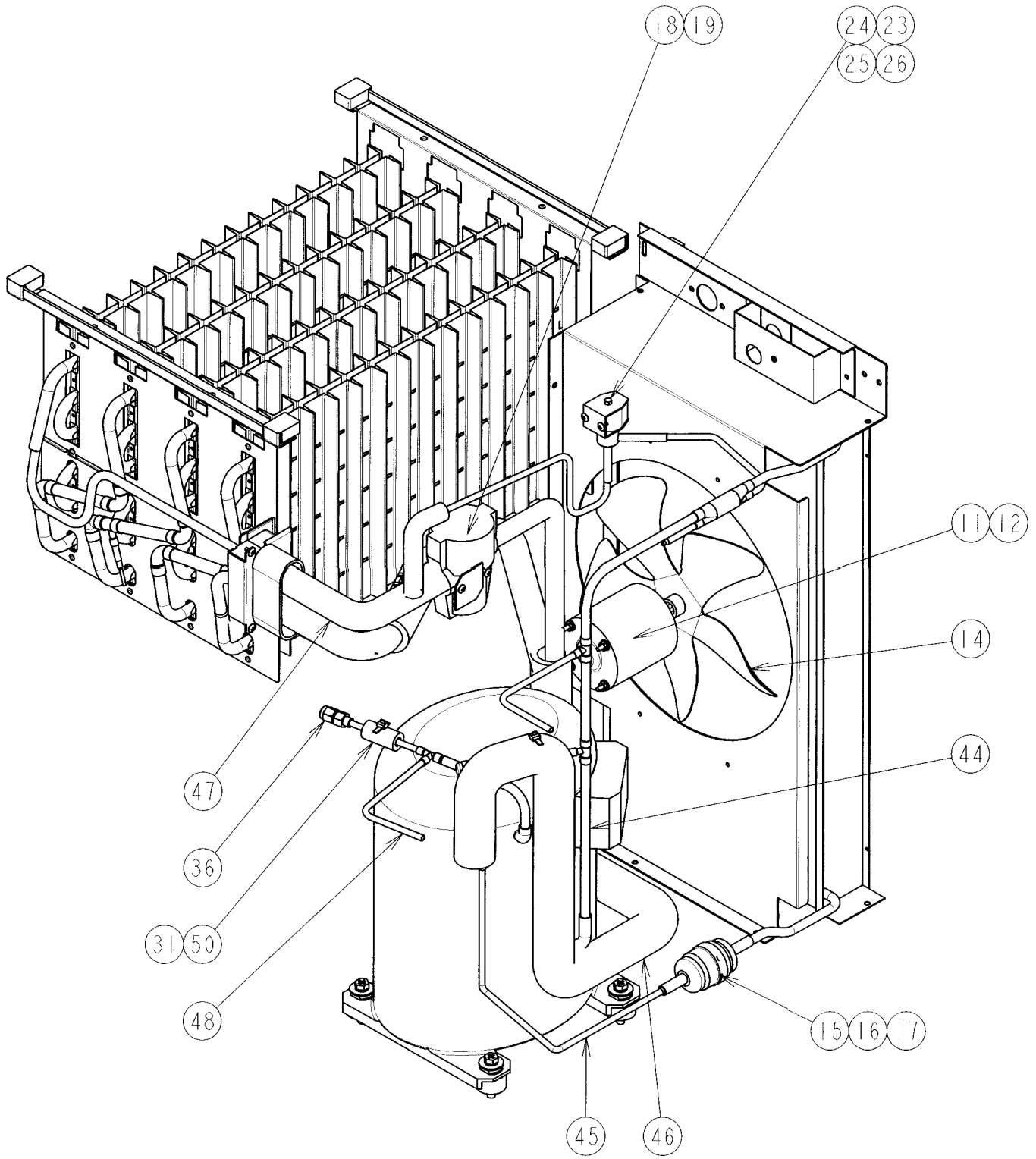

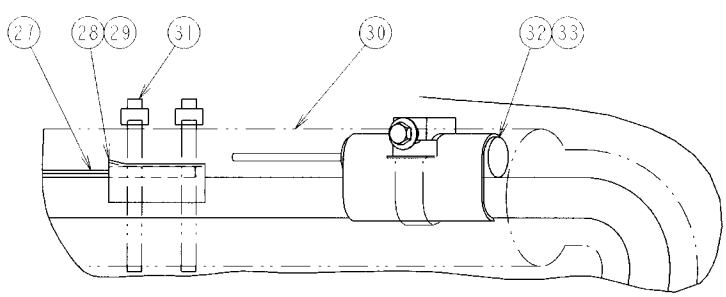
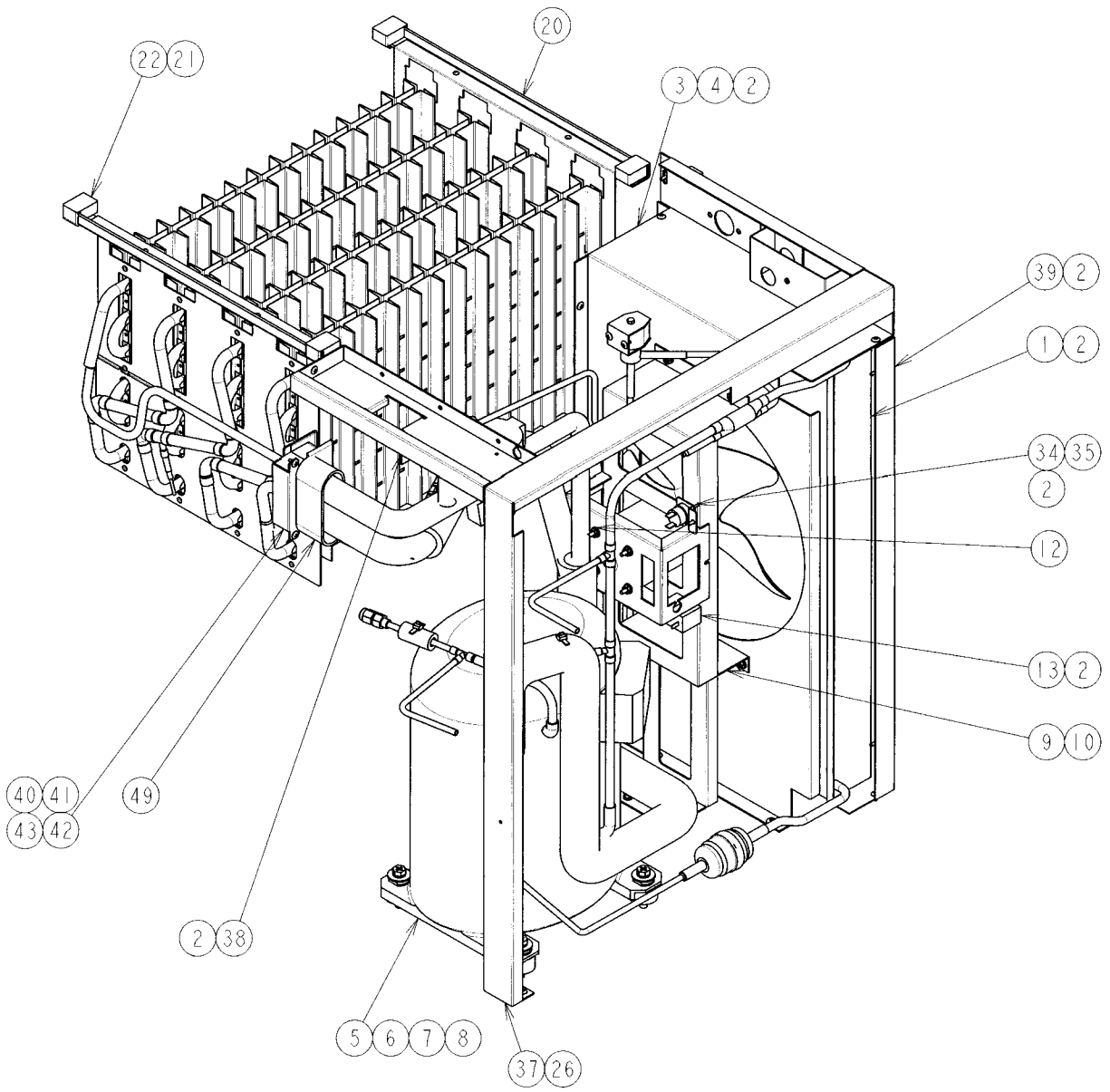

DETAILED THERMISTOR ATTACHMENT

HA

MODEL: KMD-700MAH TITLE: B. REFRIGERATION CIRCUIT									
INDEX NO.	DESCRIPTION	MATERIAL OR MODEL NUMBER	PART NUMBER	REQUIRED NUMBER					
				N-0					
1	CONDENSER	-	1A0802-01	1					
2	T2 SCREW	4x8	7P31-0408	16					
3	SHROUD	-	3A2689G01	1					
4	TRUSS HEAD SCREW	5x8	7C31-0508	2					
5	COMPRESSOR	CS10K6E-PFV-237	4A1539-01	1					
6	BOLT	8x45	437889-01	4					
7	GROMMET	027-0167-00	434922-01	4					
8	SPACER	028-0188-02	434921-01	4					
9	FAN MOTOR BRACKET	-	3A2789-01	1					
10	HEX HEAD BOLT W / WASHER (LF)	5x10	7B0130510	8					
11	FAN MOTOR	U90 B1 7190 1031	440911-01	1					
12	SELF LOCKING NUT	8-32	7N2110832	4					
13	CAPACITOR	250 VAC 5 Mfd	443192-02	1					
14	FAN BLADE	20569-17	4A0197-01	1					
15	DRIER	-	4A2666-01	1					
16	END CAP	-	4A1413F01	1					
17	NYLON TIE	-	8911-0301	1					
18	EXPANSION VALVE	-	4A2053-01	1					
19	EXP. VALVE COVER	-	4A1168-01	1					
20	EVAPORATOR	-	2A2834G01	1					
21	TRUSS HEAD SCREW	4X8, SS	7C32-0408	4					
22	FRAME SEAL	-	323925-01	4					
23	VALVE BODY	70	440352-01	1					
24	COIL-VALVE	ABS-25-1-HD-2	440353-01	1					
25	BOLT	-	440353F01	1					
26	TRUSS HEAD SCREW	4X8	7C31-0408	6					

HA

MODEL: KMD-700MAH TITLE: B. REFRIGERATION CIRCUIT										
INDEX NO.	DESCRIPTION	MATERIAL OR MODEL NUMBER	PART NUMBER	REQUIRED NUMBER						
				N-0						
27	THERMISTOR	-	429006-04	1						
28	HOLDER – THERMISTOR	COPPER	438247-01	1						
29	INSULATION – THERMISTOR	PE FOAM	427441-01	1						
30	INSULATION – TUBE	L=200	7762-2943	1						
31	CABLE TIE	-	7920-0010	4						
32	HOLDER – EXP. VALVE - 1/2	-	3A0112-01	1						
33	CLAMP	-	443461-02	1						
34	PRESSURE SWITCH	ACB-1UB09	433441-07	1						
35	PRESS. SWITCH BRCKT.	GS	434938-01	1						
36	ACCESS VALVE	-	457729-01	2						
37	SIDE FRAME	-	3A2691G01	1						
38	FRONT FRAME	-	3A2692-01	1						
39	BARRIER	-	3A2693-01	1						
40	RUBBER INSULATION (A)	-	3A2649-01	1						
41	RUBBER INSULATION (B)	-	3A2650-01	1						
42	INSULATION HOLDER	-	4A3043-01	1						
43	T2 SCREW	4x8, SS	7P32-0408	2						
44	COPPER TUBE (A) HIGH SIDE	COPPER	3A2694G01	1						
45	COPPER TUBE (B) HIGH SIDE	COPPER	3A2695-01	1						
46	HEAT EXCHANGER	-	3A2696G01	1						
47	COPPER TUBE (A) LOW SIDE	COPPER	3A2697G01	1						
48	COPPER TUBE – ACCESS VALVE	-	3A2698G01	1						
49	INSULATION	-	436671-01	1						
50	INSULATION TUBE	L=40	7762-1020	1						

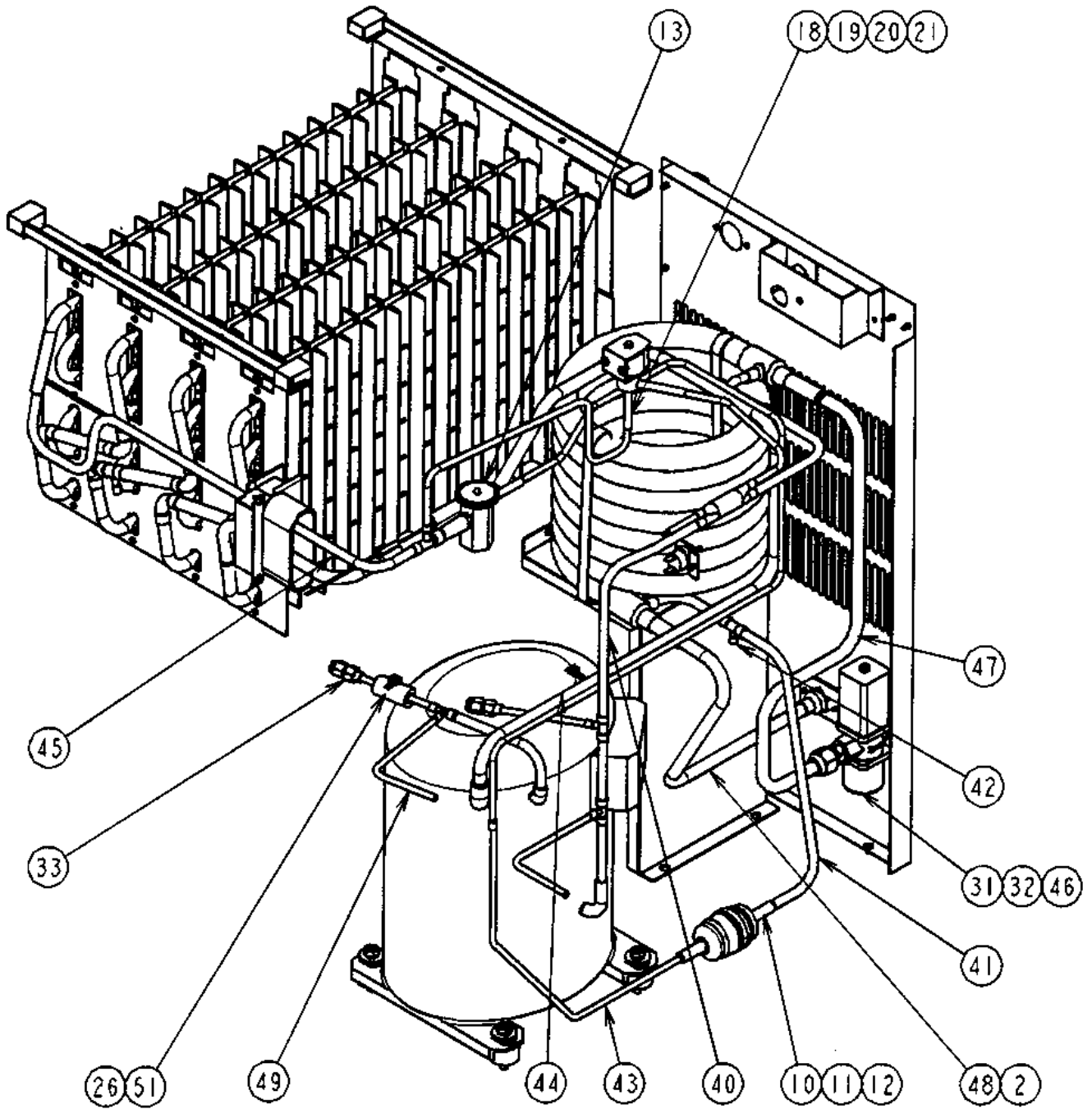

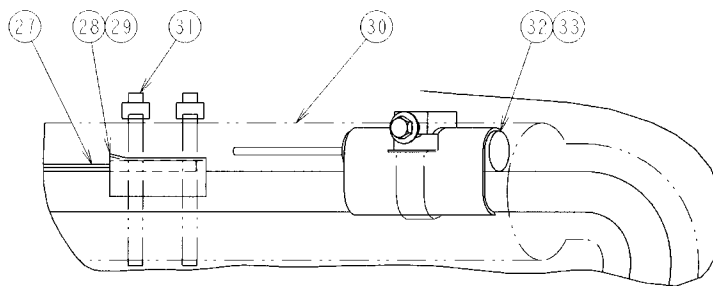
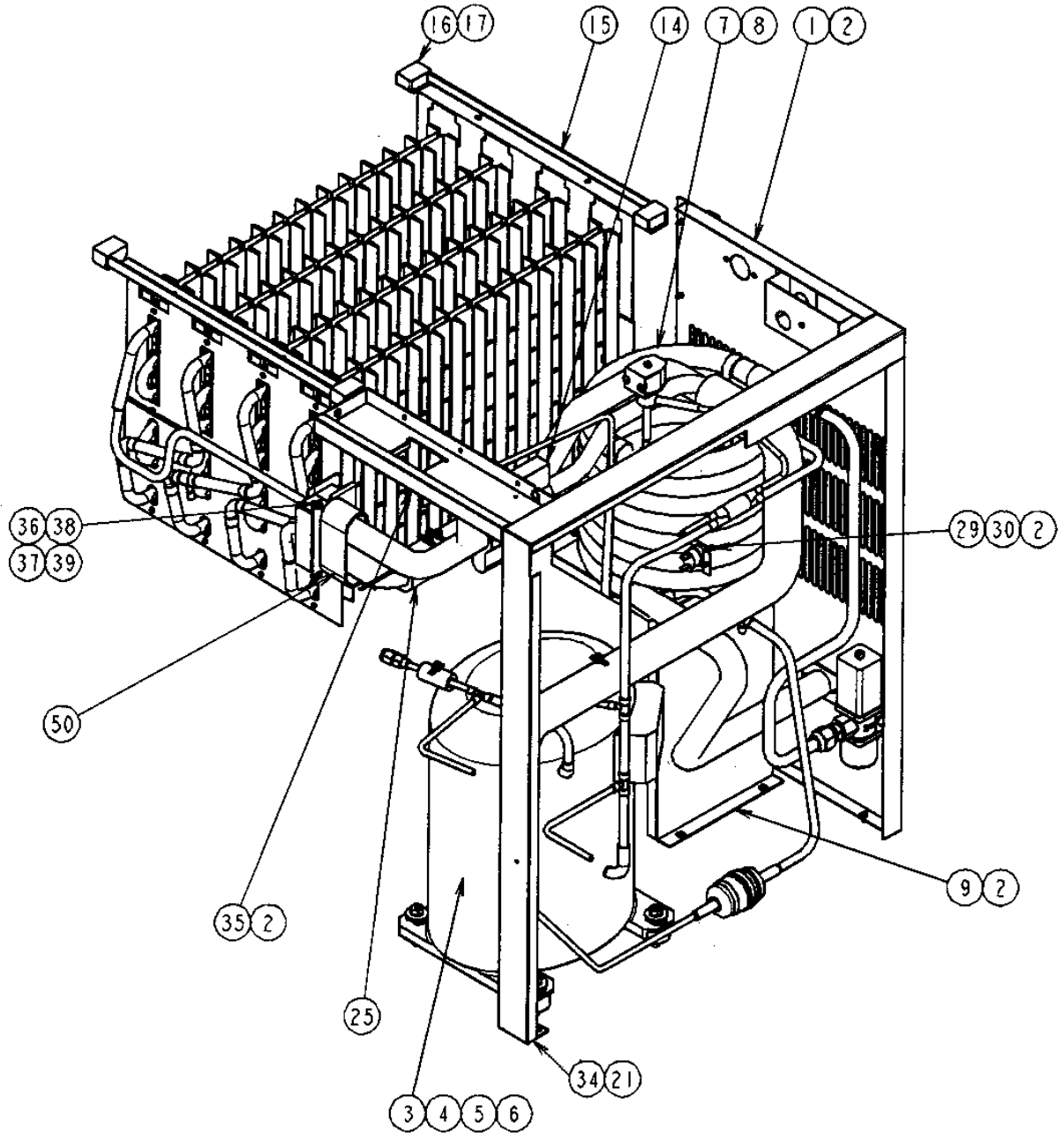

DETAILED THERMISTOR ATTACHMENT

HA

MODEL: KMD-700MWH TITLE: B. REFRIGERATION CIRCUIT										
INDEX NO.	DESCRIPTION	MATERIAL OR MODEL NUMBER	PART NUMBER	REQUIRED NUMBER						
				N-0						
1	REAR PANEL	-	3A2758G01	1						
2	T2 SCREW	4x8	7P31-0408	12						
3	COMPRESSOR	CS10K6E-PFV-237	4A1539-01	1						
4	BOLT	8x45	437889-01	4						
5	GROMMET	027-0167-00	434922-01	4						
6	SPACER	028-0188-02	434921-01	4						
7	CONDENSER – WATER COOLED	-	2A2359G03	1						
8	HEX HEAD BOLT W / WASHER (LF)	5x10	7B0130510	2						
9	CONDENSER – BRACKET	-	2A2846-01	1						
10	DRIER	-	4A2666-01	1						
11	END CAP	-	4A1413F01	1						
12	NYLON TIE	-	8911-0301	1						
13	EXPANSION VALVE	-	4A2053-01	1						
14	EXP. VALVE COVER	-	4A1168-01	1						
15	EVAPORATOR	-	2A2834G01	1						
16	FRAME SEAL	-	323925-01	4						
17	TRUSS HEAD SCREW	4X8, SS	7C32-0408	4						
18	VALVE BODY	70	440352-01	1						
19	COIL-VALVE	ABS-25-1-HD-2	440353-01	1						
20	BOLT	-	440353F01	1						
21	TRUSS HEAD SCREW	4X8	7C31-0408	1						
22	THERMISTOR	-	429006-04	1						
23	HOLDER – THERMISTOR	COPPER	438247-01	1						
24	INSULATION – THERMISTOR	PE FOAM	427441-01	1						
25	INSULATION – TUBE	L=180	7762-2943	1						
26	CABLE TIE	-	7920-0010	4						
27	HOLDER – EXP. VALVE - 1/2	-	3A0112-01	1						
28	CLAMP	-	443461-02	1						

HA

MODEL: KMD-700MWH TITLE: B. REFRIGERATION CIRCUIT										
INDEX NO.	DESCRIPTION	MATERIAL OR MODEL NUMBER	PART NUMBER	REQUIRED NUMBER						
				N-0						
29	PRESSURE SWITCH	ACB-1UB09	433441-05	1						
30	PRESS. SWITCH BRCKT.	GS	434938-01	1						
31	WATER REGULATOR	-	4A0911-06	1						
32	TRUSS HEAD SCREW	4X6	7C31-0406	2						
33	ACCESS VALVE	-	457729-01	1						
34	SIDE FRAME	-	3A2691G01	1						
35	FRONT FRAME	-	3A2692-01	1						
36	RUBBER INSULATION (A)	-	3A2649-01	1						
37	RUBBER INSULATION (B)	-	3A2650-01	1						
38	INSULATION HOLDER	-	4A3043-01	1						
39	T2 SCREW	4x8, SS	7P32-0408	2						
40	COPPER TUBE (A) HIGH SIDE	COPPER	3A2760G01	1						
41	COPPER TUBE (B) HIGH SIDE	COPPER	3A2768-01	1						
42	TEE	-	436000-06	1						
43	COPPER TUBE (C) – HIGH SIDE	COPPER	3A2762-01	1						
44	HEAT EXCHANGER	-	3A2766G01	1						
45	COPPER TUBE (A) LOW SIDE	COPPER	3A2697G01	1						
46	MALE CONNECTOR	-	4A1087-01	1						
47	COPPER TUBE – COND. OUTLET	-	4A3110G01	1						
48	COPPER TUBE – COND. INLET	-	3A2769G01	1						
49	COPPER TUBE – ACCESS VALVE	-	3A2698G01	1						
50	INSULATION	-	436671-01	1						
51	INSULATION TUBE	L=40	7762-1020	1						

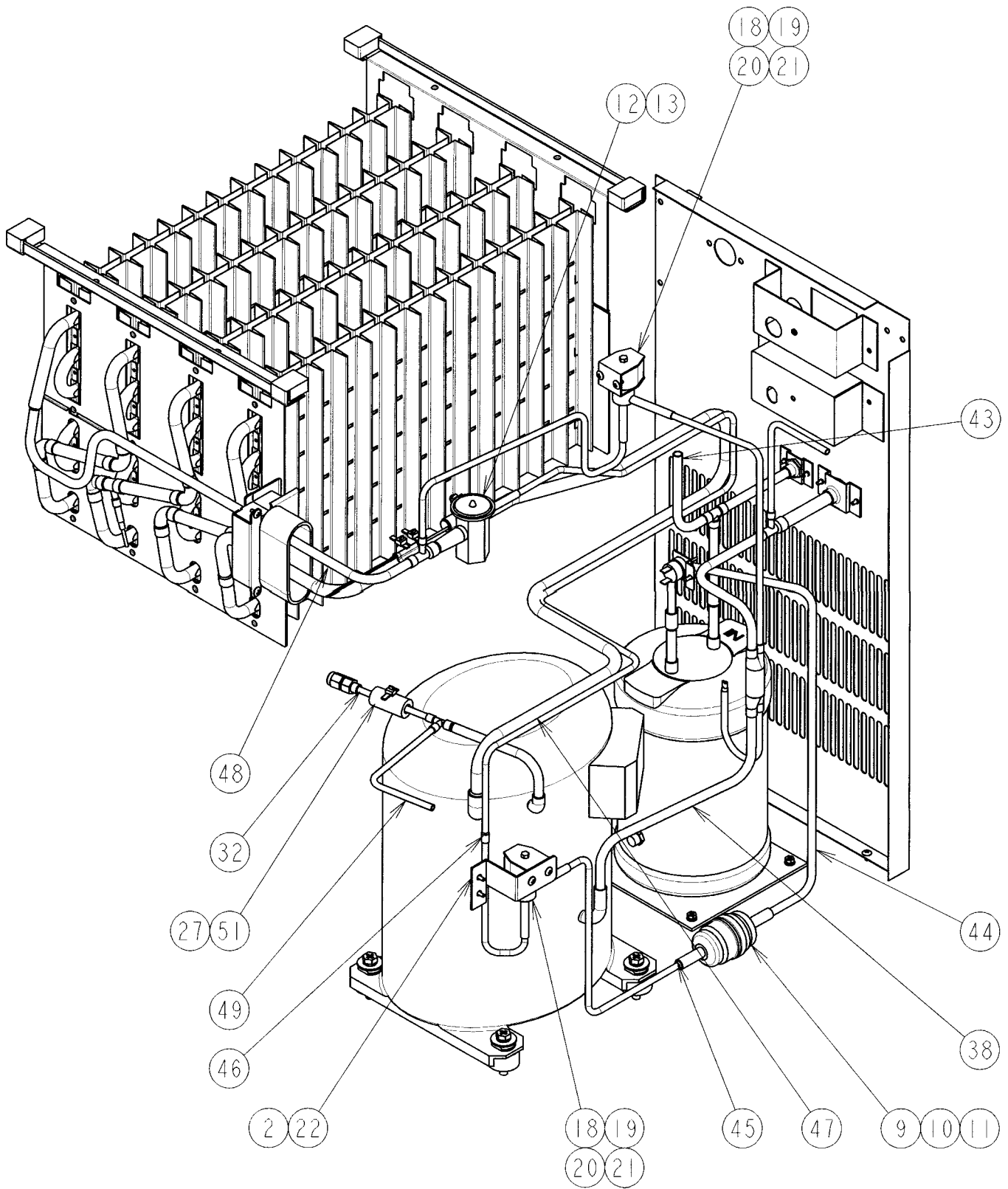

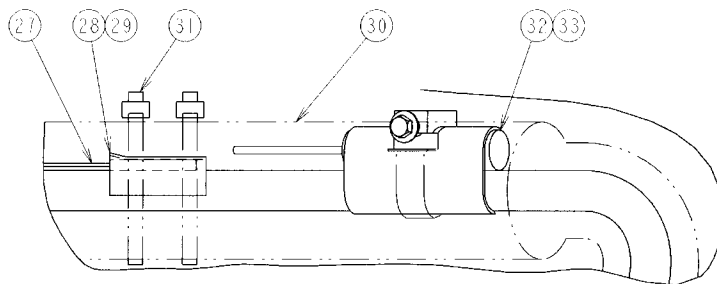
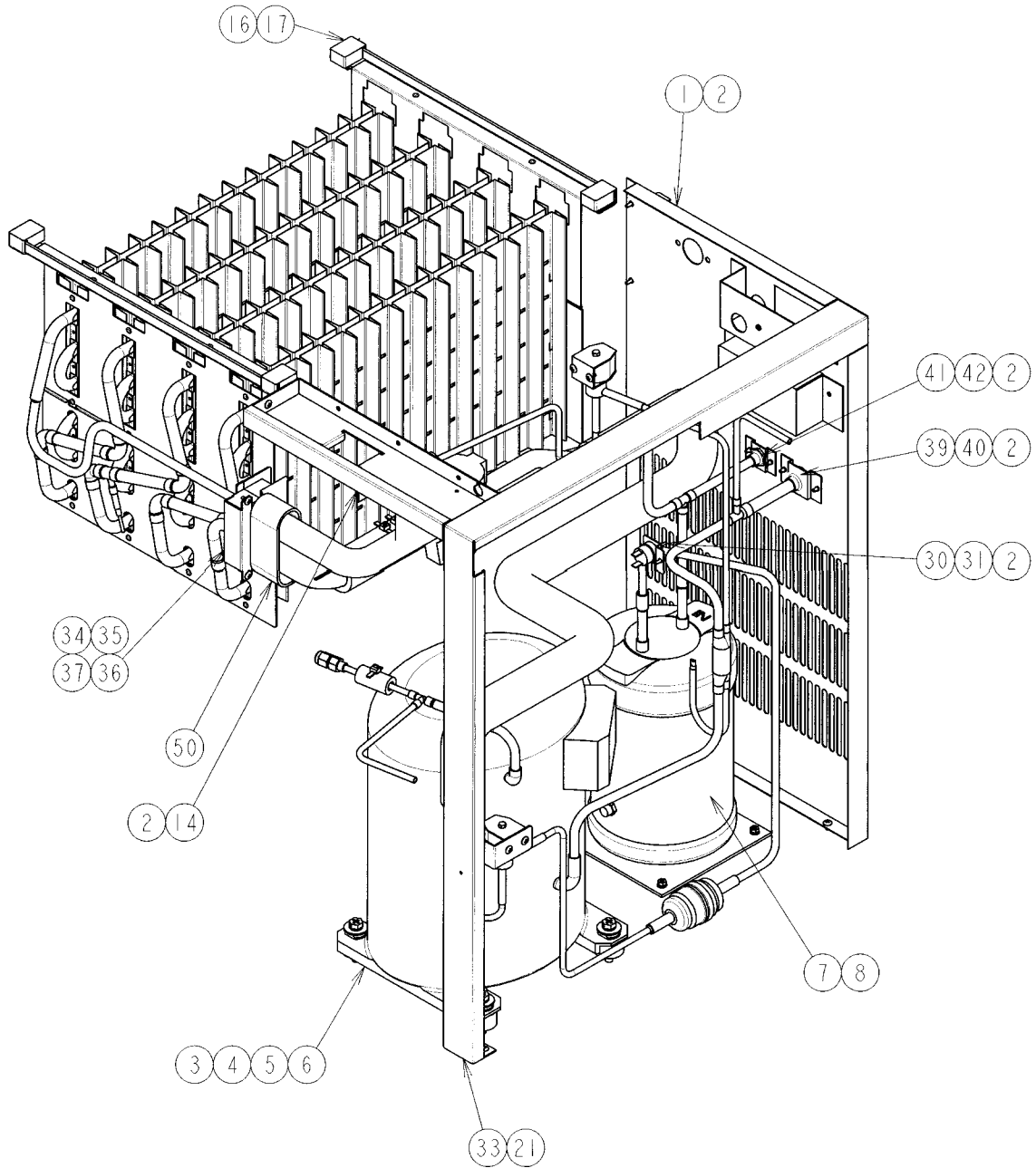

DETAILED THERMISTOR ATTACHMENT

HA

MODEL: KMD-700MRH TITLE: B. REFRIGERATION CIRCUIT										
INDEX NO.	DESCRIPTION	MATERIAL OR MODEL NUMBER	PART NUMBER	REQUIRED NUMBER						
				N-0						
1	REAR PANEL	-	3A275G01	1						
2	T2 SCREW	4x8	7P31-0408	16						
3	COMPRESSOR	CS10K6E-PFV-279	4A1539-02	1						
4	BOLT	8x45	437889-01	4						
5	GROMMET	027-0167-00	434922-01	4						
6	SPACER	028-0188-02	434921-01	4						
7	RECEIVER TANK	-	437652-01	1						
8	HEX HEAD BOLT W / WASHER (LF)	5x10	7B0130510	3						
9	DRIER	-	4A2666-01	1						
10	END CAP	-	4A1413F01	2						
11	NYLON TIE	-	8911-0301	1						
12	EXPANSION VALVE	ANE-1/4SW75	4A2053-01	1						
13	EXP. VALVE COVER	-	4A1168-01	1						
14	FRONT FRAME	-	3A2692-01	1						
15	EVAPORATOR	-	2A2834G01	1						
16	TRUSS HEAD SCREW	4X8, SS	7C32-0408	4						
17	FRAME SEAL	-	323925-01	4						
18	VALVE BODY	70	440352-01	2						
19	COIL-VALVE	ABS-25-1-HD-2	440353-01	2						
20	BOLT	-	440353F01	2						
21	TRUSS HEAD SCREW	4X8	7C31-0408	8						
22	LINE VALVE BRACKET	-	4A3037-01	1						
23	THERMISTOR	-	429006-05	1						
24	HOLDER – THERMISTOR	COPPER	438247-01	1						
25	INSULATION – THERMISTOR	PE FOAM	427441-01	1						
26	INSULATION TUBE	L=220	7762-2943	1						
27	CABLE TIE	-	7920-0010	3						

HA

MODEL: KMD-700MRH TITLE: B. REFRIGERATION CIRCUIT										
INDEX NO.	DESCRIPTION	MATERIAL OR MODEL NUMBER	PART NUMBER	REQUIRED NUMBER						
				N-0						
28	HOLDER – EXP. VALVE - 1/2	-	3A0112-01	1						
29	CLAMP	-	443461-02	1						
30	PRESSURE SWITCH	ACB-1UB09	433441-07	1						
31	PRESS. SWITCH BRCKT.	GS	434938-01	1						
32	ACCESS VALVE	-	457729-01	1						
33	SIDE FRAME	-	3A2691G01	1						
34	RUBBER INSULATION (A)	-	3A2649-01	1						
35	RUBBER INSULATION (B)	-	3A2650-01	1						
36	INSULATION HOLDER	-	4A3043-01	1						
37	T2 SCREW	4x8, SS	7P32-0408	2						
38	COPPER TUBE (A) HIGH SIDE	COPPER	3A2759G01	1						
39	COUPLING	-	434136G01	1						
40	TUBE HOLDER – L	-	438245-01	1						
41	COUPLING	-	433751G01	1						
42	TUBE HOLDER – S	-	438246-01	1						
43	COPPER TUBE (B) HIGH SIDE	COPPER	4A3038G01	1						
44	COPPER TUBE (C) – HIGH SIDE	COPPER	3A2761-01	1						
45	COPPER TUBE (D) – HIGH SIDE	COPPER	3A2763-01	1						
46	COPPER TUBE (E) – HIGH SIDE	COPPER	3A2764-01	1						
47	HEAT EXCHANGER	-	3A2765G01	1						
48	COPPER TUBE (A) LOW SIDE	COPPER	3A2697G01	1						
49	COPPER TUBE – ACCESS VALVE	-	3A2698G01	1						
50	INSULATION	-	436671-01	1						
51	INSULATION TUBE	L=40	7762-1020	1						

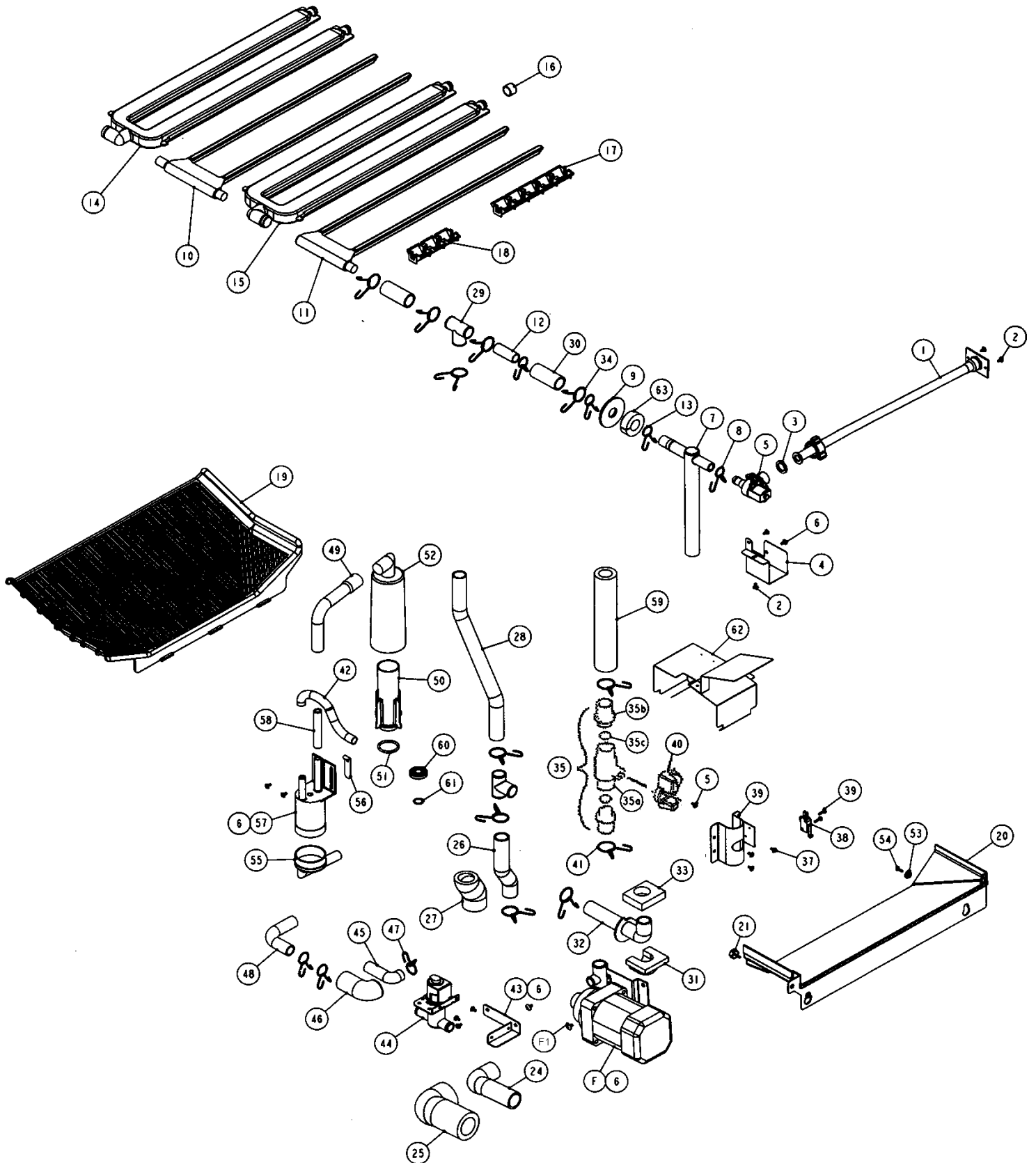

HA

MODEL: KMD-700MAH, MWH, MRH TITLE: C. WATER CIRCUIT								
INDEX NO.	DESCRIPTION	MATERIAL OR MODEL NUMBER	PART NUMBER	REQUIRED NUMBER				
				N-0				
F	PUMP MOTOR ASSEMBLY	HS-0178	2A2848A01	1				
F1	TRUSS HEAD SCREW	5X8, SS	7C32-0508	2				
1	WATER SUPPLY PIPE	-	4A0768G07	1				
2	T2 SCREW	4X8, SS	7P32-0408	4				
3	RUBBER GASKET	-	413854-03	1				
4	WATER VALVE BRACKET	-	3A2685-01	1				
5	WATER VALVE	-	4A1176-01	1				
6	TRUSS HEAD SCREW	4X8, SS	7C32-0408	8				
7	HOSE – WATER VALVE	-	3A2648-01	1				
8	HOSE CLAMP	16.5 mm, SS	427443-04	1				
9	FLANGE	-	439267-01	1				
10	WATER SUPPLY TUBE	-	2A2370-01	1				
11	WATER SUPPLY TUBE	-	2A2370-02	1				
12	VINYL HOSE	L=47	7716-1519	1				
13	HOSE CLAMP	18 mm, SS	427443-05	3				
14	SPRAY TUBE	-	2A2369-01	1				
15	SPRAY TUBE	-	2A2369-02	1				
16	SPRAY TUBE PLUG	-	3A2645-01	4				
17	SPRAY GUIDE (A)	-	208586-01	8				
18	SPRAY GUIDE (D)	-	208586-04	4				
19	CUBE GUIDE (A)	-	1A0842-01	1				
20	CUBE GUIDE (B)	-	1A0781-01	1				
21	THUMBSCREW	-	415949G10	1				
22	-	-	-					
23	-	-	-					
24	SUCTION HOSE	-	4A3001-01	1				
25	INSULATION TUBE	L=170	7762-3555	1				

HA

MODEL: KMD-700MAH, MWH, MRH TITLE: C. WATER CIRCUIT										
INDEX NO.	DESCRIPTION	MATERIAL OR MODEL NUMBER	PART NUMBER	REQUIRED NUMBER						
				N-0						
26	DISCHARGE HOSE	-	3A2646-01	1						
27	INSULATION TUBE	L=77	7762-2943	1						
28	VINYL HOSE	L=358	7716-2025	1						
29	DISTRIBUTOR	-	432426-01	1						
30	VINYL HOSE	L=63	7716-2025	2						
31	CORNER INSULATION (A)	-	439376-01	1						
32	BYPASS HOSE	-	439237-03	1						
33	CORNER INSULATION (B)	-	439392-01	1						
34	HOSE CLAMP	25 mm, SS	427443-03	9						
35	BALL VALVE ASSEMBLY	S-0761	442137A01	1						
35a	BALL VALVE	(442137A01)	439293-01	1						
35b	MALE ADAPTOR	(442137A01)	325826-01	2						
35c	"O" RING	(442137A01)	7611-P018	2						
36	VALVE HOLDER	-	3A1178-01	1						
37	FT SCREW	4X8	7F31-0408	3						
38	MICROSWITCH	-	4A2546-01	1						
39	TAPPING SCREW	3X14	431415-02	2						
40	HANDLE	-	215383-01	1						
41	HOSE CLAMP	27 mm, SS	427443-08	2						
42	HOSE – FLOAT SWITCH	-	3A2647-01	1						
43	DRAIN VALVE BRACKET	-	3A2686-01	1						
44	DRAIN VALVE	-	4A2396-01	1						
45	DRAIN HOSE – PM	-	4A3044-01	1						
46	INSULATION TUBE	L=75	7762-2636	1						
47	HOSE CLAMP	20 mm, SS	427443-06	9						
48	DRAIN HOSE	-	4A3002-01	1						
49	DRAIN HOSE – OVERFLOW	-	4A3003-01	1						

HA

MODEL: KMD-700MAH, MWH, MRH TITLE: C. WATER CIRCUIT										
INDEX NO.	DESCRIPTION	MATERIAL OR MODEL NUMBER	PART NUMBER	REQUIRED NUMBER						
				N-0						
50	OVERFLOW PIPE	-	430722-06	1						
51	"O" RING	-	4A1234-01	1						
52	OVERFLOW CAP	-	321002-01	1						
53	COLLAR	-	435269-01	2						
54	T2 FLAT HEAD SCREW	4X12, SS	7P22-0412	2						
55	CONNECTOR – FLOAT SWITCH	-	426799-03	1						
56	FLOAT SWITCH STOP	-	4A0137-01	1						
57	FLOAT SWITCH	-	4A0886-03	1						
58	SILICONE HOSE	L=80	7730I3896	1						
59	INSULATION TUBE	L=210	7762-2636	1						
60	DRAIN	-	309246-01	1						
61	"O" RING	-	7611-P015	1						
62	WATER SHIELD	-	3A2725G01	1						
63	INSULATION (E)	-	4A0392-01	1						

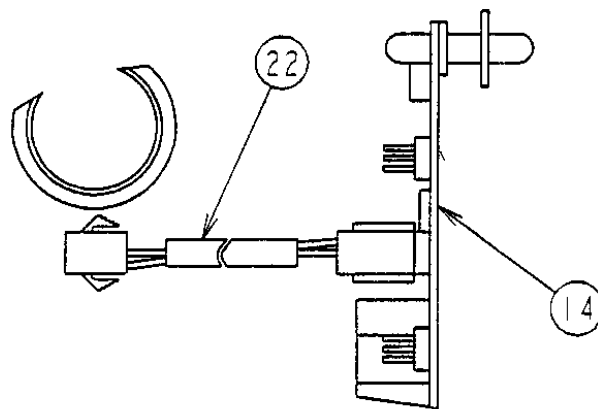
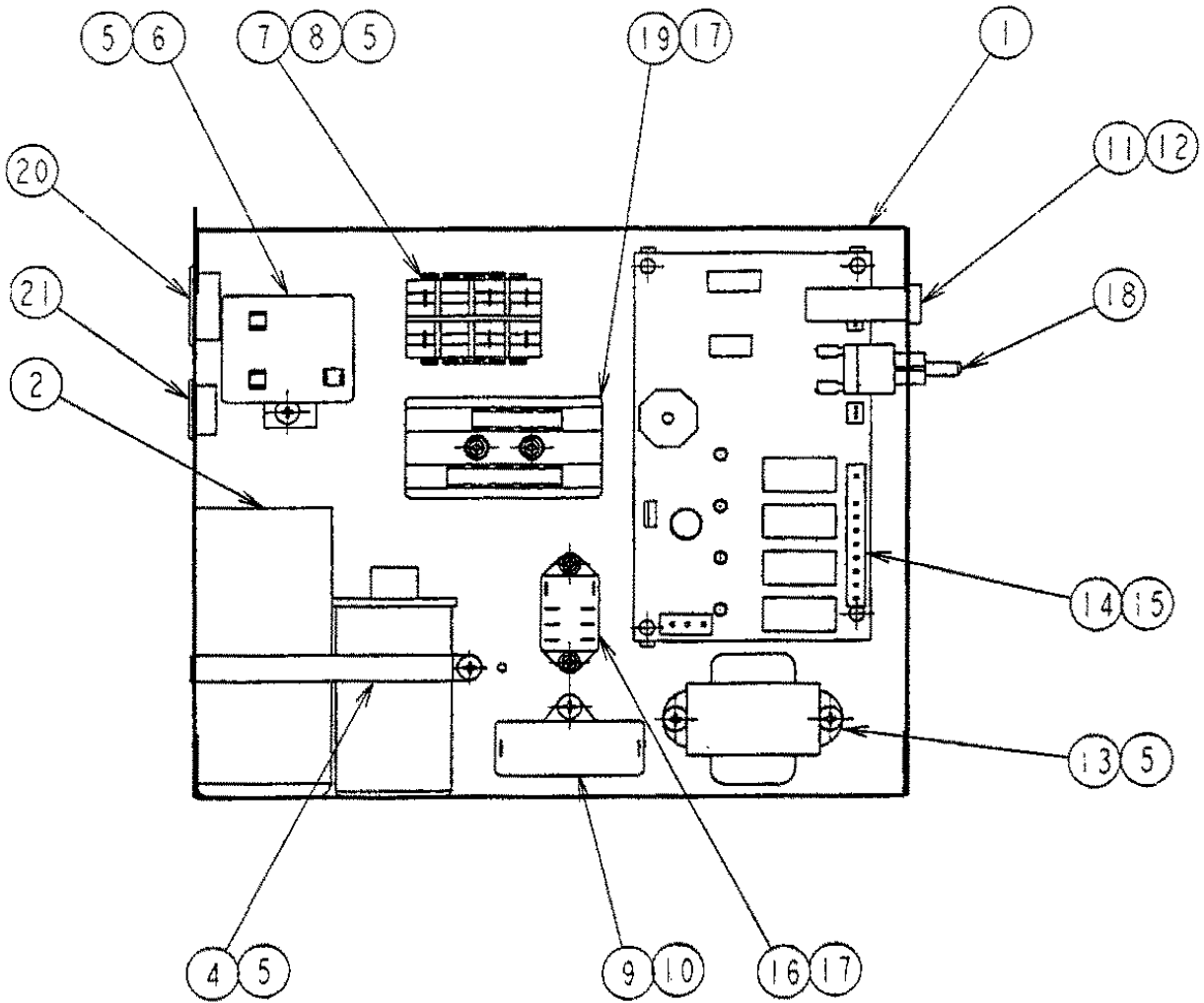

DETAIL RESISTOR WIRE HARNESS CONNECT

HA

MODEL: KMD-700MAH, MWH, MRH TITLE: D. CONTROL BOX ASSEMBLY										
INDEX NO.	DESCRIPTION	MATERIAL OR MODEL NUMBER	PART NUMBER	REQUIRED NUMBER						
				N-0						
1	CONTROL BOX	-	2A2799-01	1						
2	CAPACITOR - STARTING	145-174 MFD, 220V	3A0076-11	1						
3	CAPACITOR - RUN	35MFD 370V	3A2005-03	1						
4	STRAP	GS	4A2262-03	1						
5	T2 SCREW	4X8	7P31-0408	6						
6	STARTER	-	4A1107-13	1						
7	MAGNETIC CONTACTOR	VC20	428393-01	1						
8	BRACKET	-	428393F01	1						
9	CAPACITOR	10MFD 250V	443192-01	1						
10	T2 SCREW	4X10	7P31-0410	1						
11	FUSE HOLDER	HTB921	4A0892-01	1						
12	FUSE	AGC-10	4A0893-07	2						
13	TRANSFORMER	26D285H	3A0172-01	1						
14	CONTROLLER BOARD	HOSHIZAKI-001A	2A1410-01	1						
15	BOARD SUPPORT	OBL537-M	4A0336-03	4						
16	RELAY	LY2F 120VAC	406132-07	1						
17	TAPPING SCREW	3X8	431415-01	4						
18	TOGGLE SWITCH	8966K84	443119-01	1						
19	TERMINAL BLOCK	-	4A2619-01	1						
20	BUSHING	SB-1093-15	420470-03	1						
21	BUSHING	OCB-875	428394-04	1						
22	RESISTOR WIRE HARNESS	L=1220	4A2200G01	1						

HA
KMD-700MAH

E. LABEL LOCATION

N-0

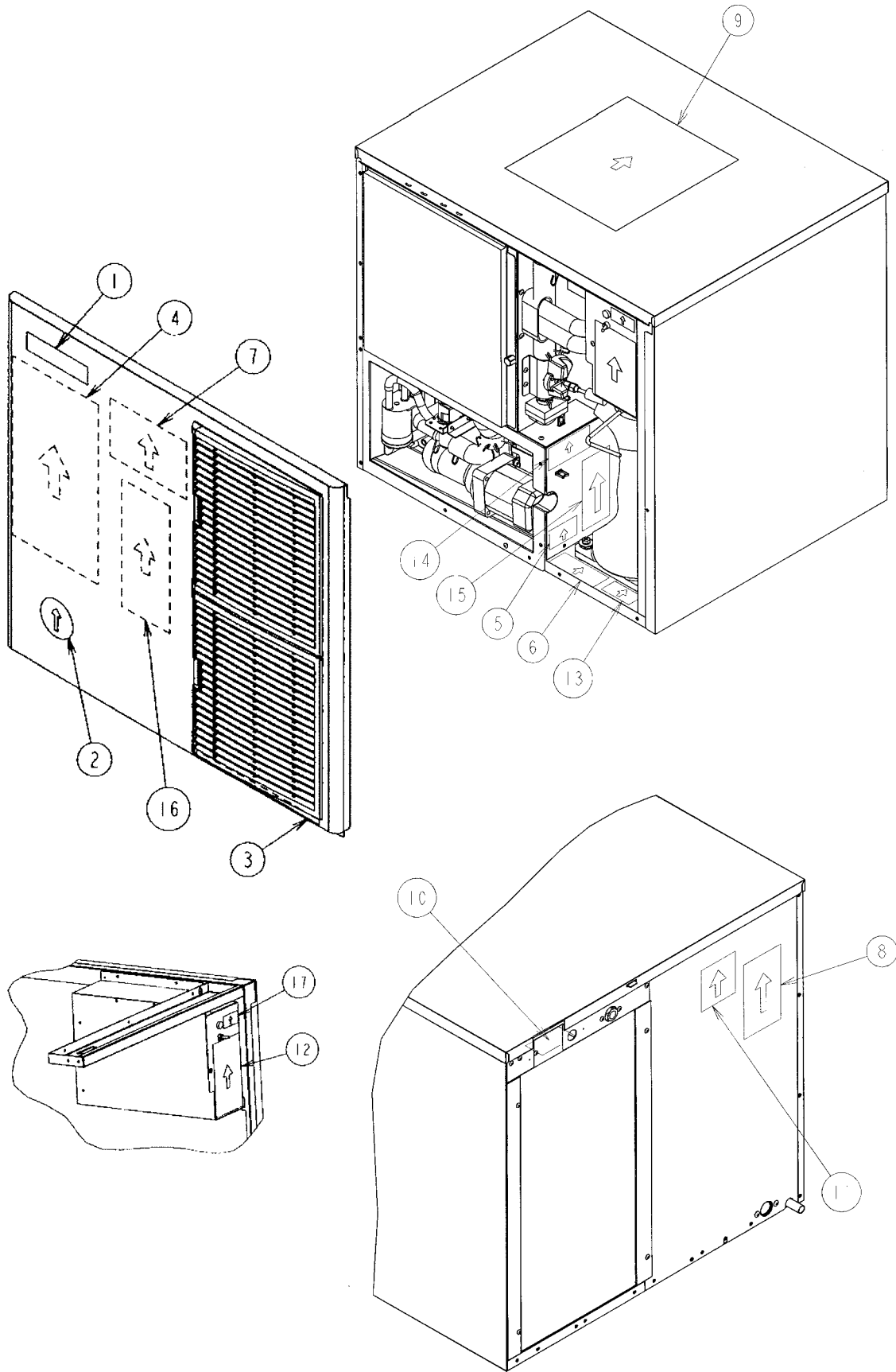

HA

MODEL: KMD-700MAH				TITLE: E. LABEL LOCATION								
INDEX NO.	DESCRIPTION	MATERIAL OR MODEL NUMBER	PART NUMBER	REQUIRED NUMBER								
				N-0								
1	EMBLEM	ABS	4A0560-01	1								
2	LABEL - PENGUIN (R)	PETP FILM	4A0526-01	1								
3	LABEL - AIR FILTER	PETP FILM	426177-01	1								
4	MAINTENANCE LABEL	PVC FILM	2A2821-01	1								
5	CAUTION LABEL (F)	PVC FILM	439146-01	1								
6	CAUTION LABEL (K)	PVC FILM	439150-01									
7	WIRING LABEL	PVC FILM	3A2730-01	1								
8	NAMEPLATE	-	2A2832-01	1								
9	INSTRUCTION SHEET	PAPER	2A2822-01	1								
10	TAG - WARNING: ELECTRICAL CONNECTION	PAPER	428430-01	1								
11	INSTRUCTION LABEL	PVC FILM	444575-01	1								
12	MANUAL LABEL	PVC FILM	3A2729-01	1								
13	LABEL – R-404A	PES FILM	4A0960-01	1								
14	OPERATION LABEL - VALVE	PVC FILM	439541-01	1								
15	RATING LABEL	-	2A2833-01	1								
16	LABEL – CONTROL BOARD	PVC FILM	3A2220-01	1								
17	LABEL –FUSE	-	4A2817-01	1								

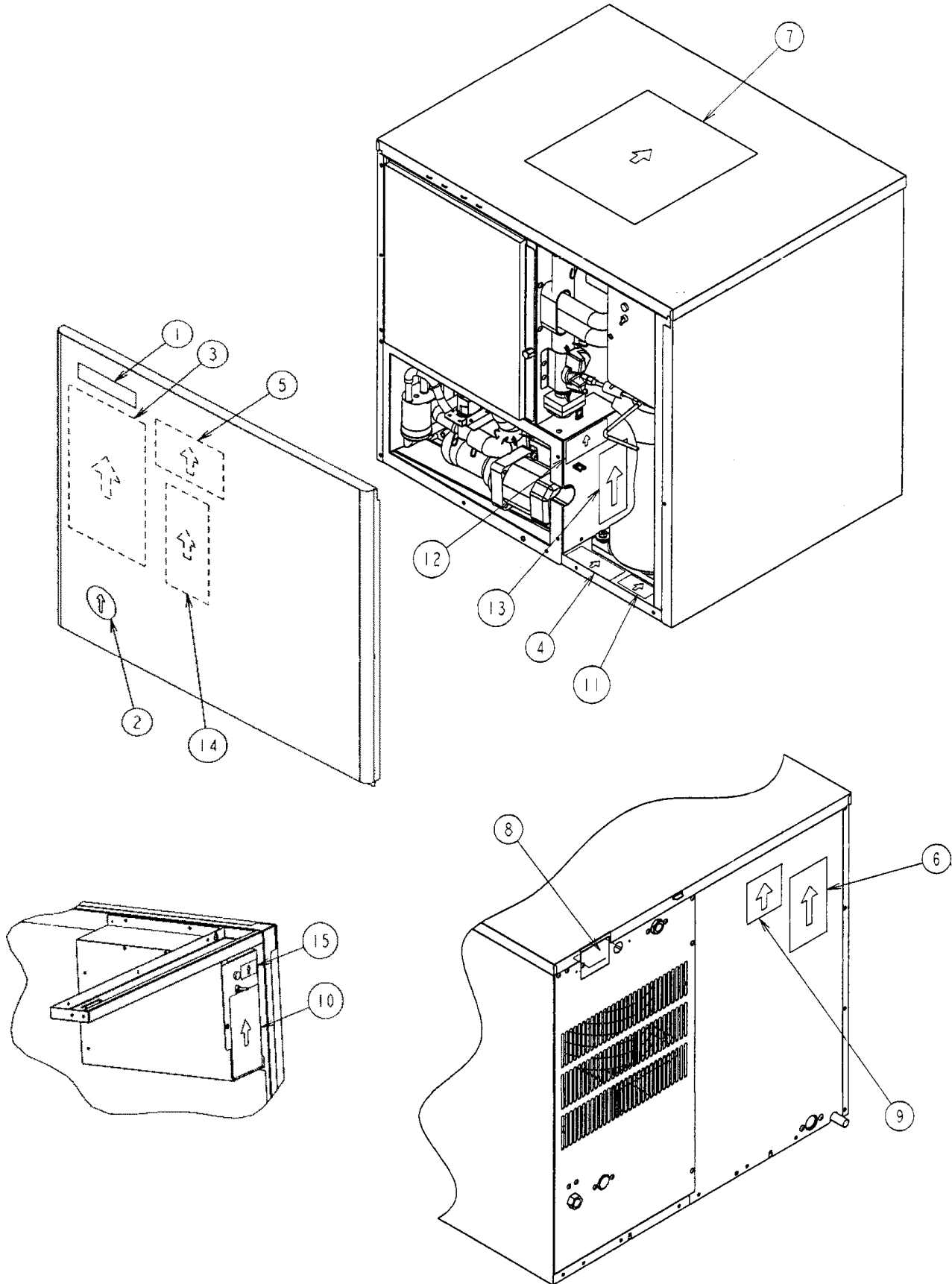

HA

MODEL: KMD-700MWH				TITLE: E. LABEL LOCATION									
INDEX NO.	DESCRIPTION	MATERIAL OR MODEL NUMBER	PART NUMBER	REQUIRED NUMBER									
				N-0									
1	EMBLEM	ABS	4A0560-01	1									
2	LABEL - PENGUIN (R)	PETP FILM	4A0526-01	1									
3	MAINTENANCE LABEL	PVC FILM	2A2821-01	1									
4	CAUTION LABEL (K)	PVC FILM	439150-01	1									
5	WIRING LABEL	PVC FILM	3A2730-01	1									
6	NAMEPLATE	-	2A2832-02	1									
7	INSTRUCTION SHEET	PAPER	2A2822-01	1									
8	TAG - WARNING: ELECTRICAL CONNECTION	PAPER	428430-01	1									
9	INSTRUCTION LABEL	PVC FILM	444575-01	1									
10	MANUAL LABEL	PVC FILM	3A2729-01	1									
11	LABEL – R-404A	PES FILM	4A0960-01	1									
12	OPERATION LABEL - VALVE	PVC FILM	439541-01	1									
13	RATING LABEL	-	2A2833-02	1									
14	LABEL – CONTROL BOARD	PVC FILM	3A2220-01	1									
15	LABEL –FUSE	-	4A2817-01	1									

HA
KMD-700MRH

E. LABEL LOCATION

N-0

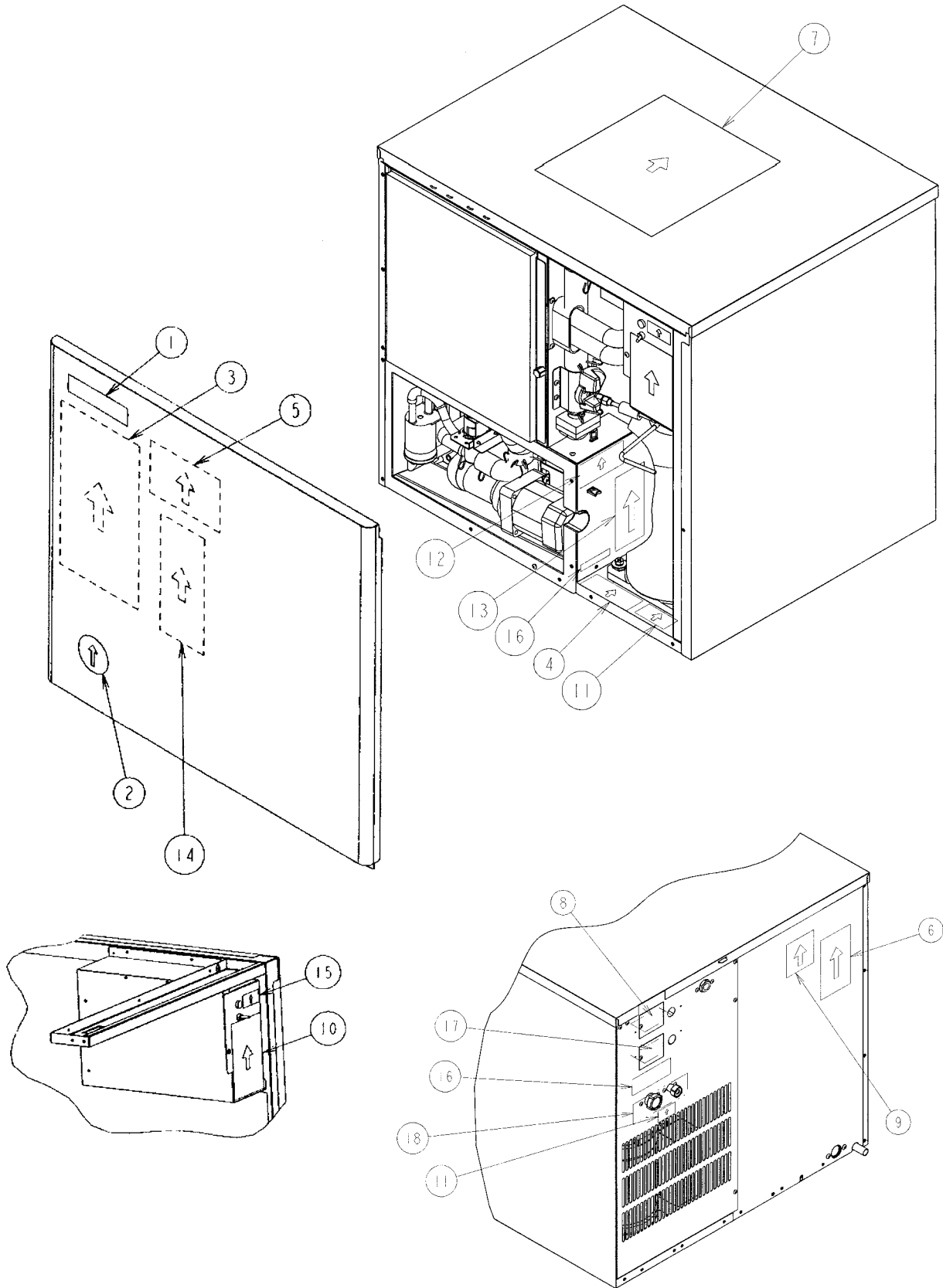

HA

MODEL: KMD-700MRH				TITLE: E. LABEL LOCATION									
INDEX NO.	DESCRIPTION	MATERIAL OR MODEL NUMBER	PART NUMBER	REQUIRED NUMBER									
				N-0									
1	EMBLEM	ABS	4A0560-01	1									
2	LABEL - PENGUIN (R)	PETP FILM	4A0526-01	1									
3	MAINTENANCE LABEL	PVC FILM	2A2821-01	1									
4	CAUTION LABEL (K)	PVC FILM	439150-01										
5	WIRING LABEL	PVC FILM	3A2767-01	1									
6	NAMEPLATE	-	2A2832-03	1									
7	INSTRUCTION SHEET	PAPER	2A2822-01	1									
8	TAG - WARNING: ELECTRICAL CONNECTION	PAPER	428430-01	1									
9	INSTRUCTION LABEL	PVC FILM	444575-01	1									
10	MANUAL LABEL	PVC FILM	3A2729-01	1									
11	LABEL – R-404A	PES FILM	4A0960-01	1									
12	OPERATION LABEL - VALVE	PVC FILM	439541-01	1									
13	RATING LABEL	-	2A2833-03	1									
14	LABEL – CONTROL BOARD	PVC FILM	3A2220-01	1									
15	LABEL –FUSE	-	4A2817-01	1									

