

NO. 71124

ISSUED: JUNE 5, 1998

REVISED: AUG. 28, 2000



**HOSHIZAKI  
MODULAR CRESCENT CUBER**

**MODEL  
KML-200MAE  
KML-200MWE**

**PARTS LIST**

HA

**KML-200MAE**

G-0	JUNE, 1997
H-0	JAN., 1998
H-1	AUG., 1998
H-2	OCT., 1998
J-0	DEC., 1998
K-0	DEC., 1999

**KML-200MWE**

G-0	AUG., 1997
H-0	DEC., 1997
H-1	APRIL, 1998
H-2	SEPT., 1998
J-0	DEC., 1998
K-0	JAN., 2000

**MATERIAL ABBREVIATIONS**

**ALUMINUM**

AL = Aluminum

**COPPER**

CU = Copper

**PLASTIC**

ABS = Acrylonitrile -butadiene - styrene  
 AC = Polyacetal  
 EVA = Ethylene vinyl acetate  
 PA = Polyamide = Nylon  
 PC = Polycarbonate  
 PE = Polyethylene  
 PES = Polyester  
 PETP = Polyethylene terephthalate = Tetlon  
 PP = Polypropylene  
 PS = Polystyrene  
 PTFE = Polytetrafluoroethylene = Teflon  
 PUR = Polyurethane  
 PVC = Polyvinyl chloride

**RUBBER**

VN = Vinyl Nitrile  
 EPDM = EP rubber  
 NBR = Nitrile butadiene rubber  
 NR = Natural rubber  
 NP = Neoprene  
 SI.R = Silicone rubber  
 SY.R = Synthetic rubber  
 EPH = Epichlorohydrin

**STEEL**

GS = Galvanized steel  
 SS = Stainless steel  
 PS = Plated steel  
 PAS = Primed steel

**AUXILIARY CODE**

Ex.1

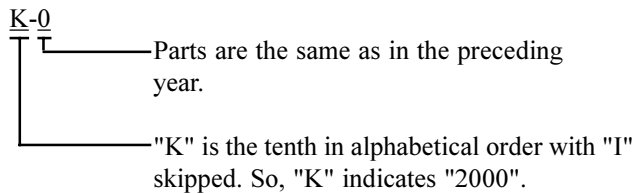

**Note:** - = Part deleted.

x = Part deleted and replaced by "o" part.

Ex.2

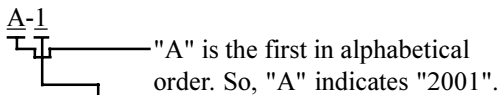

o = New part for "x" in the same auxiliary code.

Ex.3

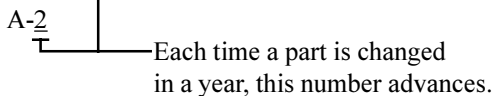

**FASTENER ABBREVIATION LIST**

ST	Phillips Truss Machine Screw
SP	Phillips Pan Head Machine Screw
SF	Phillips Flat Head Machine Screw
SS	Phillips Pan Head Machine Screw with Split Lock Washer
SW	Phillips Pan Head Machine Screw with Split Lock Washer and Flat Washer
T1	Phillips Truss Head Tapping Screw (Correspond to Type A)
T2	Phillips Truss Head Tapping Screw (Correspond to Type B)
T3	Phillips Truss Head Tapping Screw (Correspond to Type C)
FT	Phillips Truss Head Tapping Screw (Special)
BH	Hexagon Head Bolt
BC	Socket Head Cap Screw
BS	Hexagon Bolt with Split Washer
BW	Hexagon Bolt with Split Washer and Flat Washer
BF	Hexagon Flange Bolt
BR	Cross-Recessed Hexagon Head Bolt
BRW	Cross-Recessed Hexagon Head Bolt with Split Lock Washer and Flat Washer
WL	Split Lock Washer
WT	External Tooth Washer
WF	Flat Washer
WS	Spring Washer
NH	Hexagon Nut
NF	Hexagon Flange Nut
NC	Hexagon Cap Nut
NS	Square Nut
NW	Wing Nut

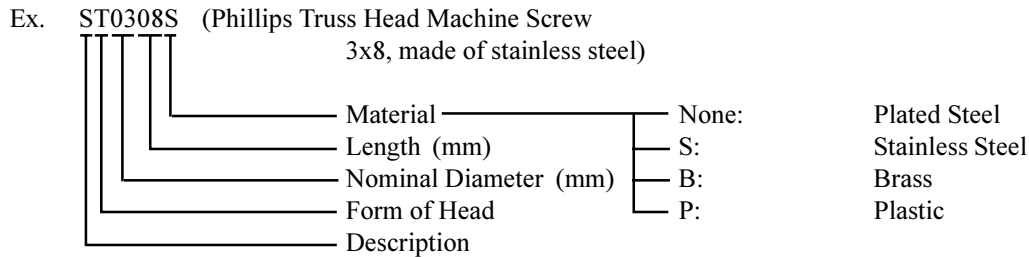

(Note) Second character is numerical except toe list.

Ex. S1, S2, B3 etc.

And abbreviations and names are shown under the illustration.

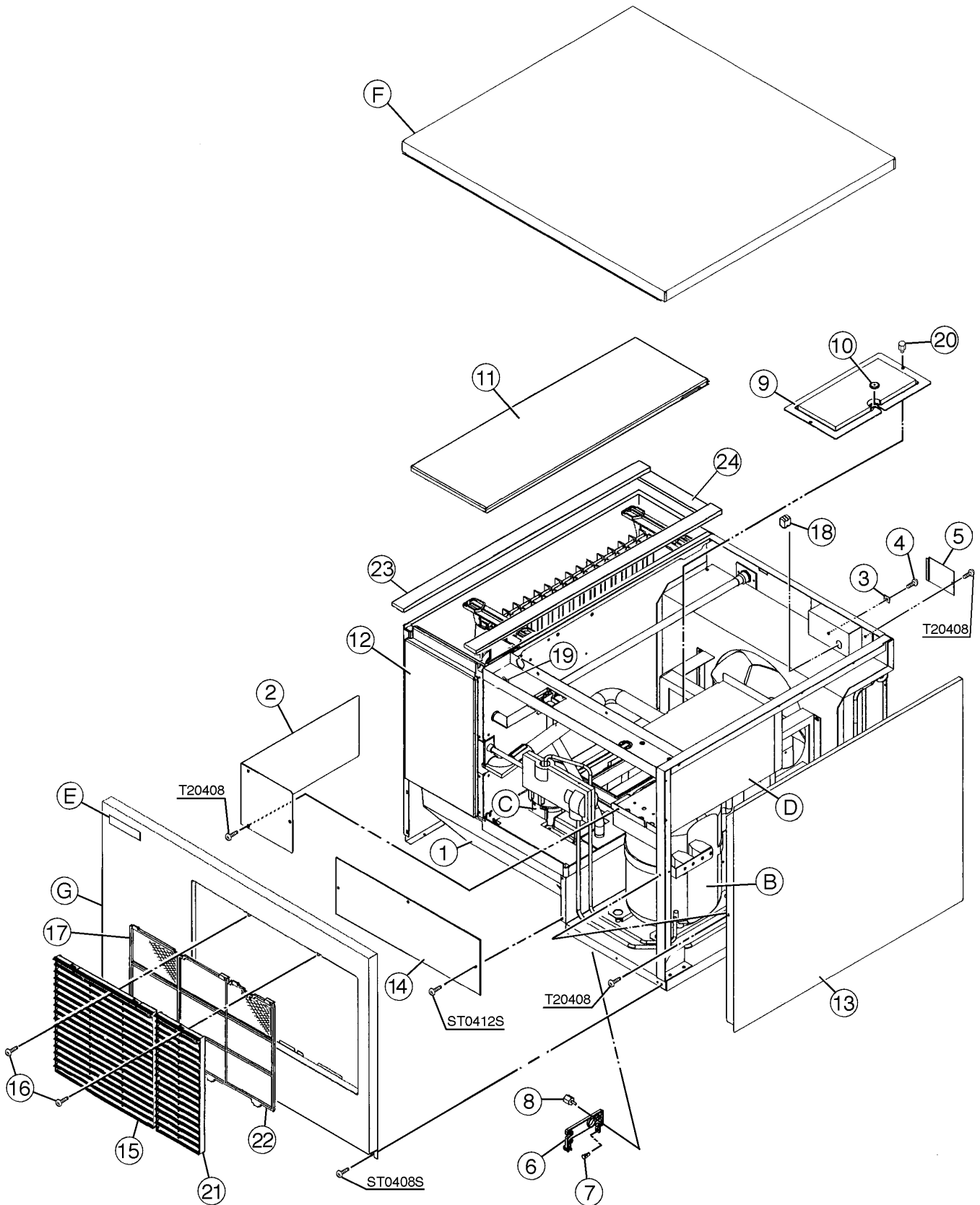

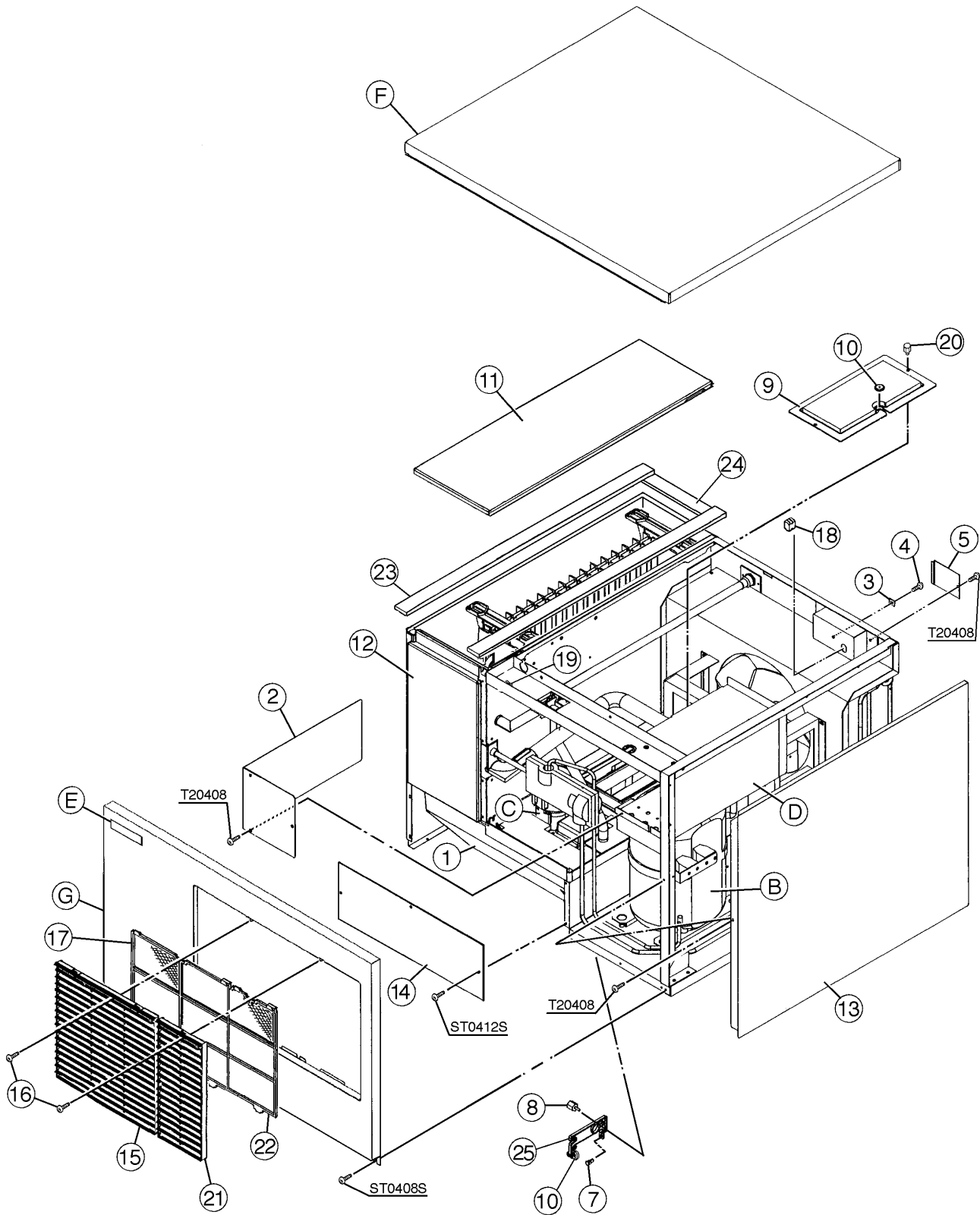

HA

KML-200MAE

A. ICE CUBER ASSEMBLY

J00786C-J01485L, K-0

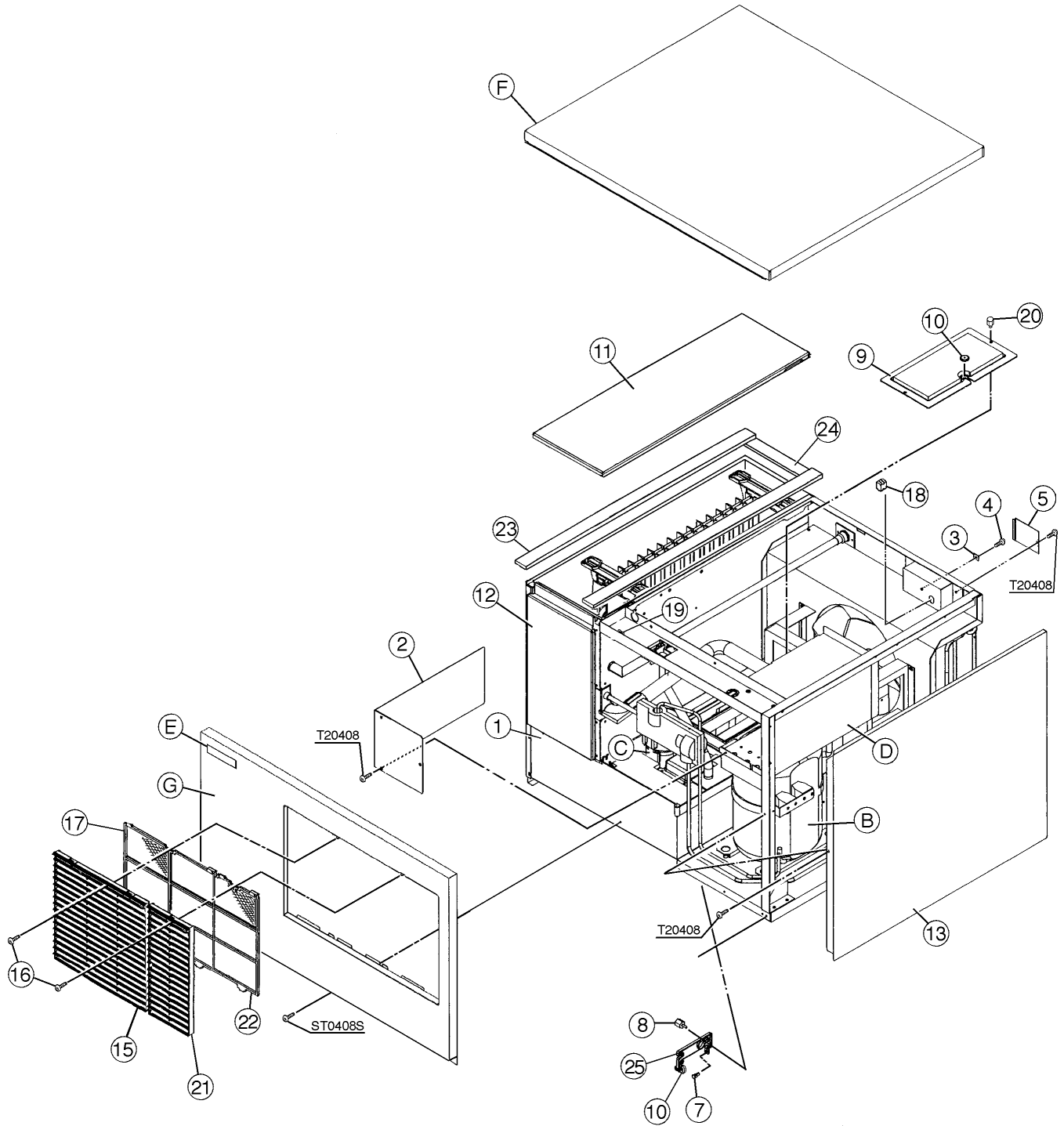

HA

MODEL: <b>KML-200MAE</b> TITLE: <b>A. ICE CUBER ASSEMBLY</b>								
INDEX NO.	DESCRIPTION	MATERIAL OR MODEL NUMBER	PART NUMBER	REQUIRED NUMBER				
				G-0 H-0	H-1	H-2	J00636M- J00785B	J00786C- J01485L K-0
B	REFRIGERATION CIRCUIT	-	2A0772A01	1	1	1	1	1
C	WATER CIRCUIT	-	2A0774A01	1	1	1	1	-
		-	1A0451A01					1
D	CONTROL BOX ASSEMBLY	-	2A0657A03	1	-			
		-	2A0657A07		1	1	1	1
	T2 SCREW	4X8	7P31-0408	3	3	3	3	3
E	LABEL LOCATION	-	3A0785A01	1	-			
		-	3A0785A02		1	1	1	-
		-	3A1380A01					1
F	TOP PANEL ASSEMBLY	-	3A0674A01	1	1	1	1	1
G	FRONT PANEL ASSEMBLY	-	3A0905A01	1	1	1	1	-
		-	3A1273A01					1
	TRUSS HEAD SCREW	4X8, SS	7C32-0408	2	2	2	2	1
1	EVAPORATOR CASE	-	2A0687G02	1	1	1	1	-
		-	2A1449G02					1
2	CONTROL BOX COVER	GS	3A0594-01	1	1	1	1	1
	T2 SCREW	4X8	7P31-0408	3	3	3	3	3
3	SQUARE WASHER	BRASS	433537-02	1	1	1	1	1
4	SCREW - GROUNDING	BRASS	433304-02	1	1	1	1	1
5	JUNCTION BOX COVER	GS	433410-01	1	1	1	1	1
	T2 SCREW	4X8	7P31-0408	1	1	1	1	1
6	BULB HOLDER	PE	328919-01	1	1	-	-	
7	SPACER	PE	443545-01	1	1	1	1	1
8	THUMBSCREW	SS, ABS	415949G03	2	2	2	2	2
9	BIN CONTROL COVER	GS	3A0664G01	1	1	1	1	1
10	CAPILLARY RING	EP RUBBER	425307-01	1	1	2	2	2
11	TOP INSULATION	PP	215730G01	1	1	1	1	1



HA

MODEL: <b>KML-200MAE</b> TITLE: <b>A. ICE CUBER ASSEMBLY</b>								
INDEX NO.	DESCRIPTION	MATERIAL OR MODEL NUMBER	PART NUMBER	REQUIRED NUMBER				
				G-0 H-0	H-1	H-2	J00636M- J00785B	J00786C- J01485L K-0
12	FRONT INSULATION	PP	<a href="#">2A0664G01</a>	1	1	1	1	1
13	SIDE PANEL (R)	SS	<a href="#">2A0649G01</a>	1	1	1	1	-
		SS	<a href="#">2A1456G01</a>					1
	T2 SCREW	4X8, SS	<a href="#">7P32-0408</a>	1	1	1	1	1
14	COVER - MANUAL FILL	ABS, POLYOLEFIN	<a href="#">4A1015G01</a>	1	1	1	1	-
	TRUSS HEAD SCREW	4X12, SS	<a href="#">7C32-0412</a>	3	3	3	3	-
15	LOUVER (B)	ABS	<a href="#">103121-05</a>	1	1	1	1	1
16	TAPPING SCREW (BLACK)	STEEL, 4X8	<a href="#">433954-01</a>	2	2	2	2	2
17	AIR FILTER (B)	ABS	<a href="#">208283G03</a>	1	1	1	1	1
18	BUSHING	SR-30-1	<a href="#">420472-03</a>	1	1	1	1	1
19	WIRE SADDLE	VWS4238-C	<a href="#">4A0338-02</a>	2	2	2	2	2
20	THUMBSCREW	SS, ABS	415949G04	2	2	2	2	2
21	LOUVER (C)	ABS	<a href="#">103122-03</a>	1	1	1	1	1
22	AIR FILTER (C)	ABS	<a href="#">208284G01</a>	1	1	1	1	1
23	GASKET	L=655	<a href="#">4A0808L02</a>	2	2	2	2	2
24	GASKET	L=190	<a href="#">4A0808L02</a>	1	1	1	1	1
25	THERMOSTAT EXTENSION BRACKET	-	4A1722-01			1	1	1

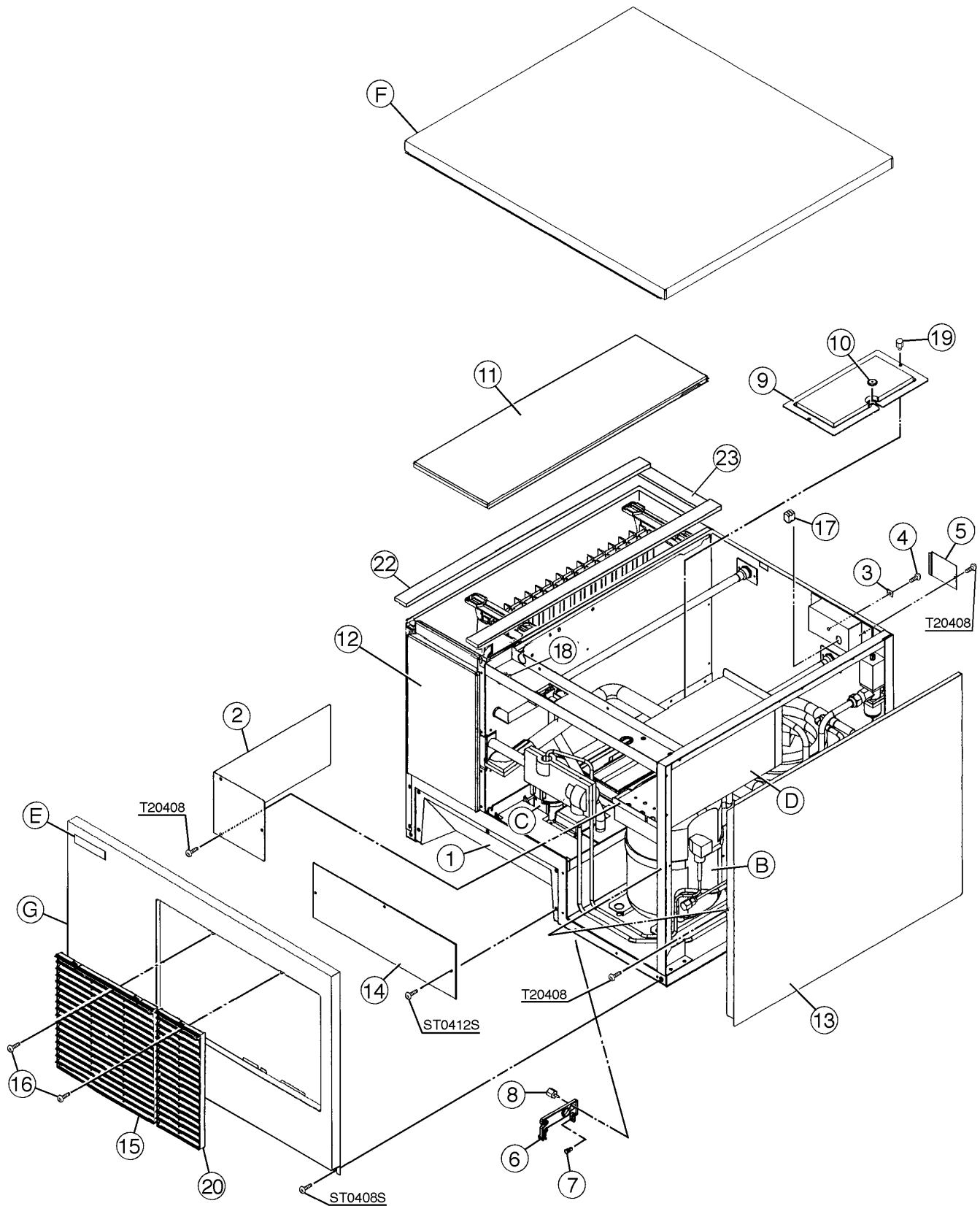

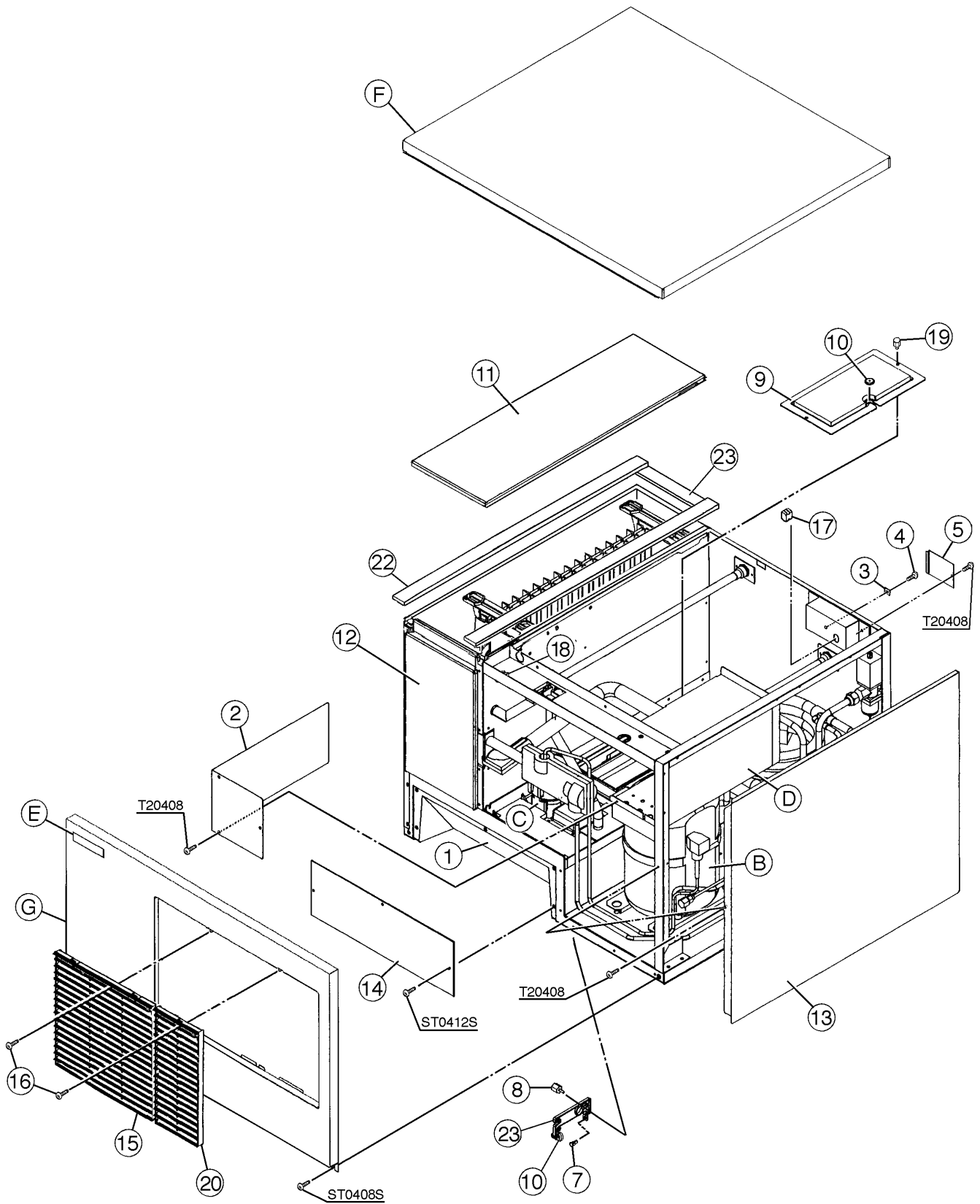

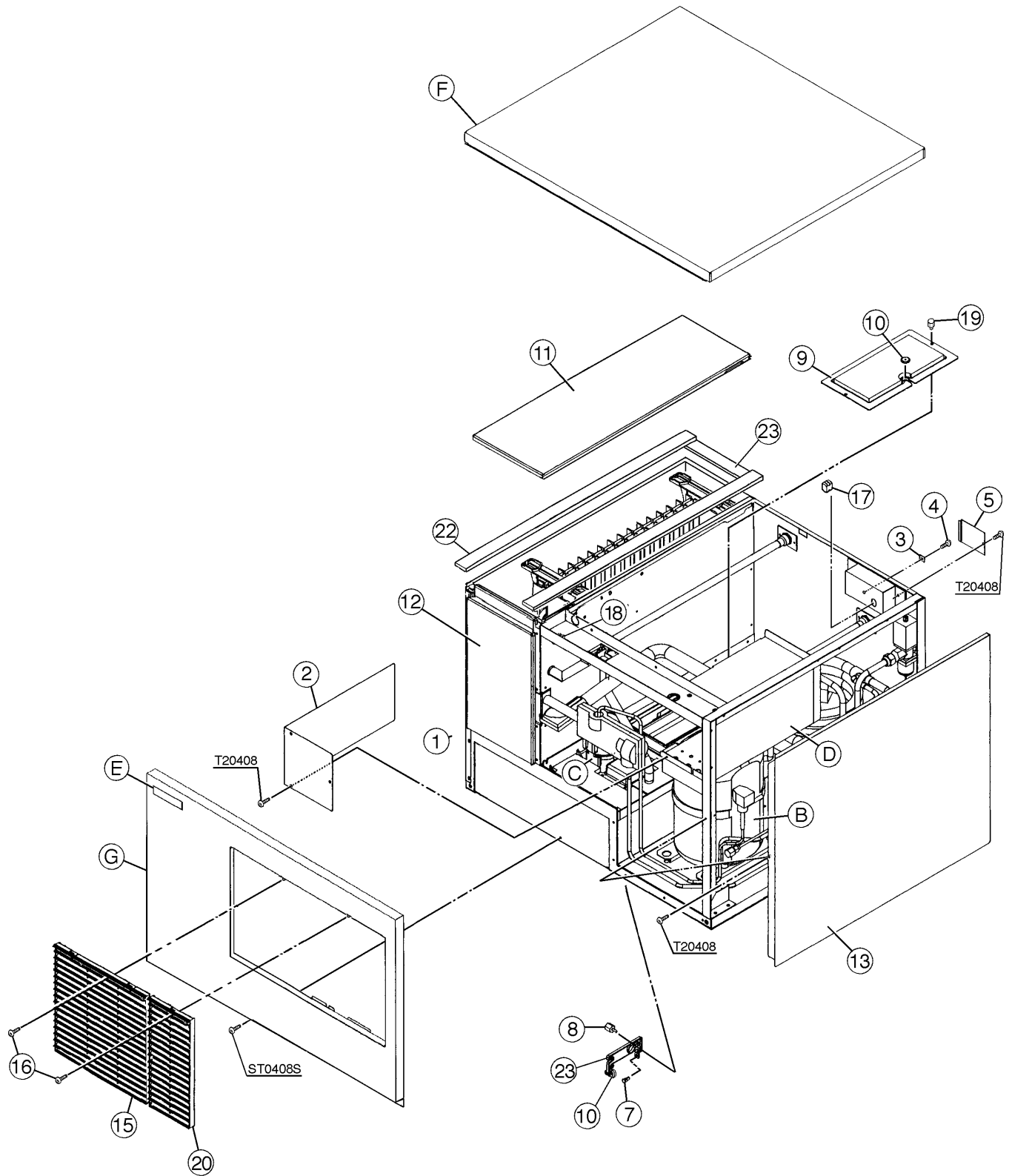

MODEL: <b>KML-200MWE</b> TITLE: <b>A. ICE CUBER ASSEMBLY</b>								
INDEX NO.	DESCRIPTION	MATERIAL OR MODEL NUMBER	PART NUMBER	REQUIRED NUMBER				
				G-0 H-0	H-1	H-2	J00196M- J00295B	J00296D- J00425J K-0
B	REFRIGERATION CIRCUIT	-	2A0773A01	1	1			
C	WATER CIRCUIT	-	2A0774A01	1	1	1	1	-
		-	1A0438A01					1
D	CONTROL BOX ASSEMBLY	-	2A0657A04	1	-			
		-	2A0657A08		1	1	1	1
	T2 SCREW	4X8	7P31-0408	3	3	3	3	3
E	LABEL LOCATION	-	3A0786A01	1	-			
		-	3A0786A02		1	1	1	-
		-	3A1381A01					1
F	TOP PANEL ASSEMBLY	-	3A0674A01	1	1	1	1	1
G	FRONT PANEL ASSEMBLY	-	3A0905A01	1	1	1	1	-
		-	3A1273A01					1
	TRUSS HEAD SCREW	4X8, SS	7C32-0408	2	2	2	2	1
1	EVAPORATOR CASE	-	2A0687G02	1	1	1	1	-
		-	2A1449G02					1
2	CONTROL BOX COVER	GS	3A0594-01	1	1	1	1	1
	T2 SCREW	4X8	7P31-0408	3	3	3	3	3
3	SQUARE WASHER	BRASS	433537-02	1	1	1	1	1
4	SCREW - GROUNDING	BRASS	433304-02	1	1	1	1	1
5	JUNCTION BOX COVER	GS	433410-01	1	1	1	1	1
	T2 SCREW	4X8	7P31-0408	1	1	1	1	1
6	BULB HOLDER	PE	328919-01	1	1	-		
7	SPACER	PE	443545-01	1	1	1	1	1
8	THUMBSCREW	SS, ABS	415949G03	2	2	2	2	2
9	BIN CONTROL COVER	GS	3A0664G01	1	1	1	1	1
10	CAPILLARY RING	EP RUBBER	425307-01	1	1	2	2	2
11	TOP INSULATION	PP	215730G01	1	1	1	1	1

MODEL: <b>KML-200MWE</b> TITLE: <b>A. ICE CUBER ASSEMBLY</b>								
INDEX NO.	DESCRIPTION	MATERIAL OR MODEL NUMBER	PART NUMBER	REQUIRED NUMBER				
				G-0 H-0	H-1	H-2	J00196M- J00295B	J00296D- J00425J K-0
12	FRONT INSULATION	PP	<a href="#">2A0664G01</a>	1	1	1	1	1
13	SIDE PANEL (R)	SS	<a href="#">2A0649G01</a>	1	1	1	1	-
		SS	<a href="#">2A1456G01</a>					1
	T2 SCREW	4X8, SS	<a href="#">7P32-0408</a>	1	1	1	1	1
14	COVER - MANUAL FILL	ABS, POLYOLEFIN	<a href="#">4A1015G01</a>	1	1	1	1	1
	TRUSS HEAD SCREW	4X12, SS	<a href="#">7C32-0412</a>	3	3	3	3	3
15	LOUVER (B)	ABS	<a href="#">103121-05</a>	1	1	1	1	1
16	TAPPING SCREW (BLACK)	STEEL, 4X8	<a href="#">433954-01</a>	2	2	2	2	2
17	BUSHING	SR-30-1	<a href="#">420472-03</a>	1	1	1	1	1
18	WIRE SADDLE	VWS4238-C	<a href="#">4A0338-02</a>	2	2	2	2	2
19	THUMBSCREW	SS, ABS	415949G04	2	2	2	2	2
20	LOUVER (C)	ABS	<a href="#">103122-03</a>	1	1	1	1	1
21	GASKET	L=655	<a href="#">4A0808L02</a>	2	2	2	2	2
22	GASKET	L=190	<a href="#">4A0808L02</a>	1	1	1	1	1
23	THERMOSTAT EXTENSION BRACKET	-	4A1722-01			1	1	1

HA

KML-200MAE

B. REFRIGERATION CIRCUIT

G-0, H-0, H-1, H-2

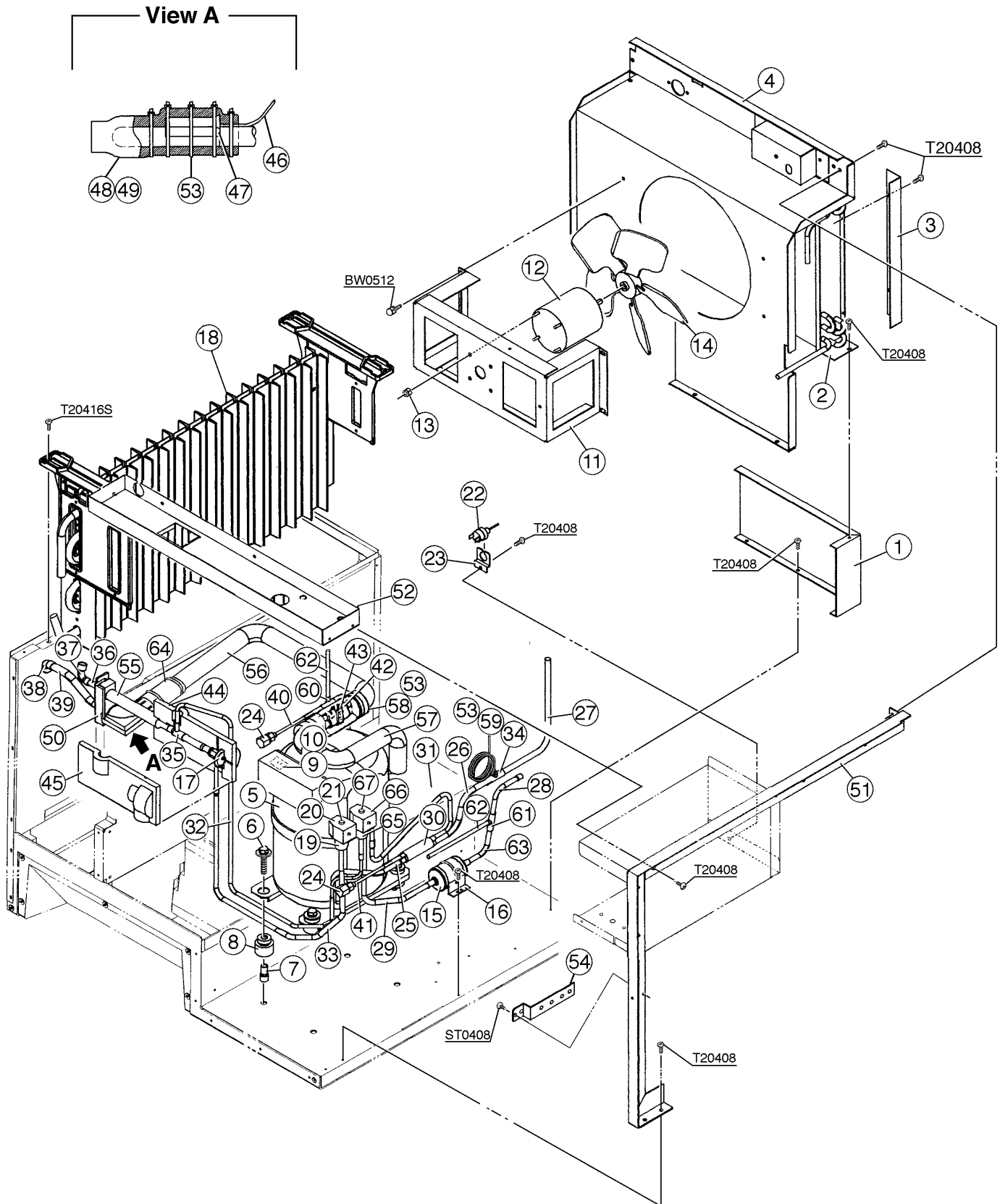

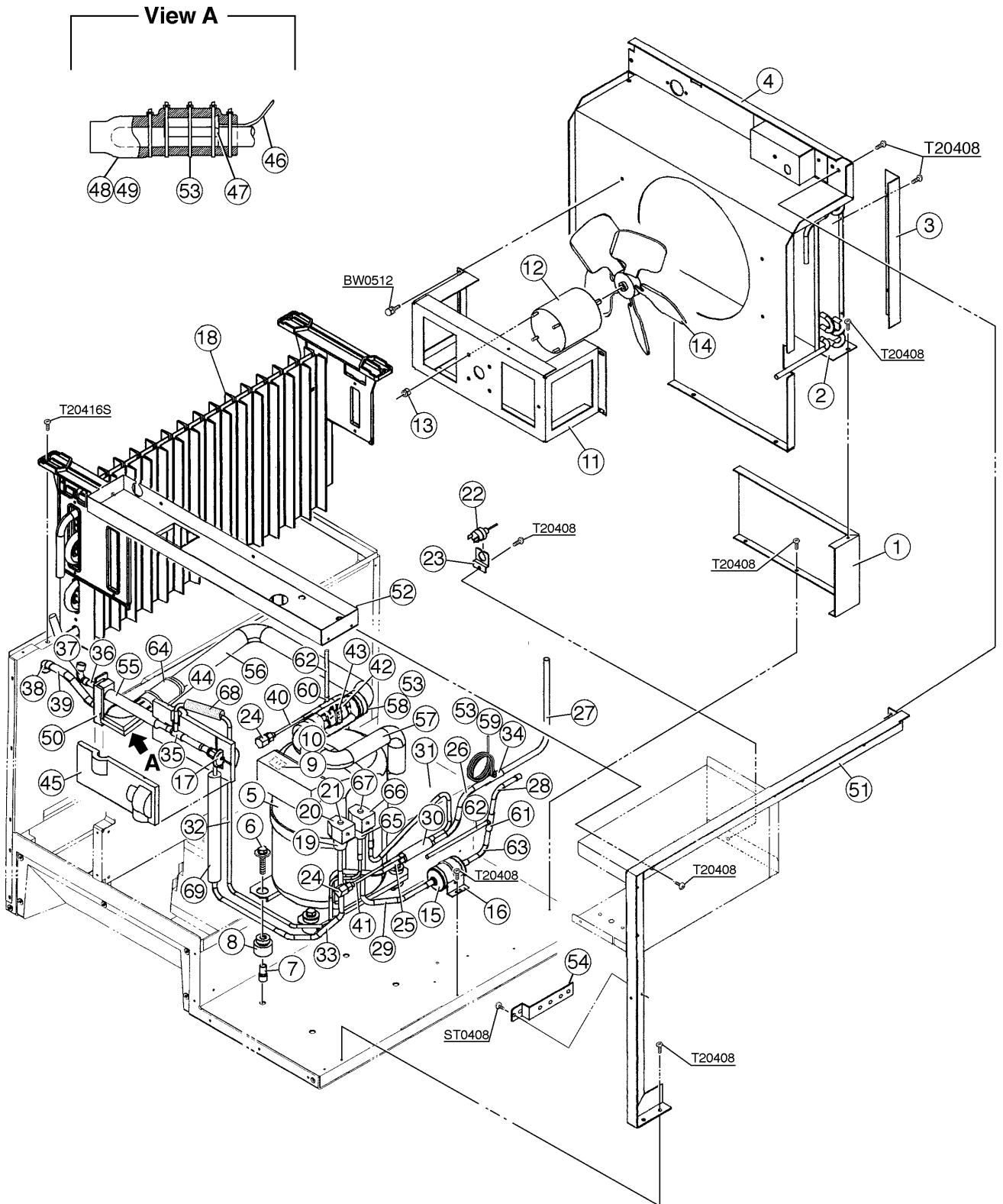



MODEL: KML-200MAE TITLE: B. REFRIGERATION CIRCUIT								
INDEX NO.	DESCRIPTION	MATERIAL OR MODEL NUMBER	PART NUMBER	REQUIRED NUMBER				
				G-0	H-0	H-1	H-2	J-0 K-0
1	CONDENSER SUPPORT	GS	3A0589-01	1	1	1	1	1
	T2 SCREW	4X8	7P31-0408	5	5	5	5	5
2	CONDENSER	-	2A0779-01	1	1	1	1	1
	T2 SCREW	4X8	7P31-0408	3	3	3	3	3
3	BARRIER	GS	4A0932-01	1	1	1	1	1
	T2 SCREW	4X8	7P31-0408	2	2	2	2	2
4	SHROUD	GS	3A0597G01	1	1	1	1	1
	T2 SCREW	4X8	7P31-0408	5	5	5	5	5
5	COMPRESSOR	RSU4-0050-CAA	436634-01	1	1	1	1	1
6	BOLT	8 x 45	437889-01	4	4	4	4	4
7	SPACER	027-0072-02	434404-01	4	4	4	4	4
8	GROMMET	527-0039-04	434403-01	4	4	4	4	4
9	MOTOR PROTECTOR	071-0370-30	437340-01	1	1	1	1	1
10	PROTECTOR HOLDER	SS	437339-01	1	1	1	1	1
11	FAN MOTOR BRACKET	GS	2A0181-01	1	1	1	1	1
	HEX HEAD BOLT W/WASHER (LF)	5X12	7B0130512	4	4	4	4	4
12	FAN MOTOR	U90B1, 7190-1031	440911-01	1	1	1	1	1
13	SELF-LOCKING NUT	SS	7N2110832	4	4	4	4	4
14	FAN BLADE	AD10CW32	444898-01	1	1	1	1	1
15	DRIER	C-0325-S	445007-01	1	1	1	1	1
16	DRIER BRACKET	GS	4A0807-01	1	1	1	1	1
	T2 SCREW	4X8	7P31-0408	2	2	2	2	2
17	EXPANSION VALVE	HFE-5HHD-5	446461-01	1	1	1	1	1
18	EVAPORATOR ASSEMBLY	-	2A0775G01	1	1	1	1	1
	T2 SCREW	4X16, SS	7P32-0416	4	4	4	4	4
19	VALVE BODY	70	440352-01	1	1	1	1	1
20	COIL - VALVE	ABS-25-1-HD-2	440353-01	1	1	1	1	1

HA

MODEL: <b>KML-200MAE</b> TITLE: <b>B. REFRIGERATION CIRCUIT</b>								
INDEX NO.	DESCRIPTION	MATERIAL OR MODEL NUMBER	PART NUMBER	REQUIRED NUMBER				
				G-0	H-0	H-1 H-2	J-0	K-0
21	BOLT	-	440353F01	1	1	1	1	1
	TRUSS HEAD SCREW	4X8	7C31-0408	4	4	4	4	4
22	PRESSURE SWITCH	ACB-2UB04	433441-05	1	1	1	1	1
23	PRESSURE SWITCH BRCKT.	GS	434938-01	1	1	1	1	1
	T2 SCREW	4X8	7P31-0408	1	1	1	1	1
24	ACCESS VALVE	TCJ-2F15-HD	417366-01	2	2	2	2	2
25	COPPER TUBE (A) - HIGH SIDE	COPPER	4A0986-01	1	1	1	1	1
26	COPPER TUBE (B) - HIGH SIDE	COPPER	4A0987-01	1	1	1	1	1
27	COPPER TUBE (C) - HIGH SIDE	COPPER	4A0989-01	1	1	1	1	1
28	COPPER TUBE (D) - HIGH SIDE	COPPER	4A0991-01	1	1	1	1	1
29	COPPER TUBE (E) - HIGH SIDE	COPPER	3A0768-01	1	1	1	1	1
30	COPPER TUBE (F) - HIGH SIDE	COPPER	3A0769-01	1	1	1	1	1
31	STRAINER	-	4A0397-01	1	1	1	1	1
32	COPPER TUBE (A) - HOT GAS	COPPER	3A0770-01	1	1	1	1	1
33	COPPER TUBE (B) - HOT GAS	COPPER	2A0832-01	1	1	1	1	1
34	TEE	COPPER	431618-01	1	1	1	1	1
35	TEE	COPPER	436000-08	1	1	1	1	1
36	COPPER TUBE (A) - LOW SIDE	COPPER	4A1183-01	1	1	1	1	1
37	ELBOW	COPPER	4A1059-01	1	1	1	1	1
38	ELBOW	COPPER	417395-03	1	1	1	1	1
39	COPPER TUBE - LOW SIDE	COPPER	2A0682-01	1	1	1	1	1
40	COPPER TUBE (A) - ACCESS VALVE	COPPER	4A1009-01	1	1	1	1	1
41	COPPER TUBE (B) - ACCESS VALVE	COPPER	4A1010-01	1	1	1	1	1
42	HOLDER / EXPANSION VALVE - 3/8	SS	3A0107-01	1	1	1	1	1
43	CLAMP	SS	443461-02	1	1	1	1	1
44	EXPANSION VALVE COVER (A)	PE FOAM	322621-01	1	1	1	1	1
45	EXPANSION VALVE COVER (B)	PE FOAM	322621-02	1	1	1	1	1
46	THERMISTOR	-	429006-03	1	1	1	1	1
47	HOLDER - THERMISTOR	COPPER	427430-01	1	1	1	1	1

MODEL: <b>KML-200MAE</b> TITLE: <b>B. REFRIGERATION CIRCUIT</b>								
INDEX NO.	DESCRIPTION	MATERIAL OR MODEL NUMBER	PART NUMBER	REQUIRED NUMBER				
				G-0	H-0	H-1 H-2	J-0	K-0
48	INSULATION - THERMISTOR (A)	PE FOAM	<a href="#">439368-01</a>	1	1	1	1	1
49	INSULATION - THERMISTOR (B)	PE FOAM	<a href="#">439368-02</a>	1	1	1	1	1
50	INSULATED RUBBER TUBE	EPDM	<a href="#">4A1008G01</a>	1	1	1	1	1
51	FRAME (A)	GS	<a href="#">2A0645-01</a>	1	1	1	1	1
	T2 SCREW	4X8	<a href="#">7P31-0408</a>	4	4	4	4	4
52	FRAME (B)	GS	<a href="#">3A0595-01</a>	1	1	1	1	1
	T2 SCREW	4X8	<a href="#">7P31-0408</a>	4	4	4	4	4
53	CABLE TIE	CV-200	7920-0010	14	14	14	14	14
54	LINE VALVE BRACKET	GS	<a href="#">438213-01</a>	1	1	1	1	1
	T2 SCREW	4X8	<a href="#">7P31-0408</a>	2	2	2	2	2
55	INSULATION TUBE	L=110	<a href="#">7762-1030</a>	1	1	1	1	x1
		L=140	<a href="#">7762-1030</a>					o1
56	INSULATION TUBE	L=580	<a href="#">7762-1330</a>	1	1	1	1	1
57	INSULATION TUBE	L=330	<a href="#">7762-1330</a>	1	1	1	1	1
58	INSULATION TUBE	L=140	<a href="#">7762-2943</a>	1	1	1	1	1
59	INSULATION TUBE	L=30	<a href="#">7762-1020</a>	2	2	2	2	2
60	EVACUATION TUBE	COPPER	4A1212-01	2	2	2	2	2
61	TEE	COPPER	420041-02	1	1	1	1	1
62	COPPER TUBE (D2) – HIGH SIDE	COPPER	4A1213-01	1	1	1	1	1
63	TEE	COPPER	436000-13	1	1	1	1	1
64	INSULATION TUBE	L=60	<a href="#">7762-2943</a>	1	1	1	1	1
65	VALVE BODY	24	<a href="#">440351-01</a>	1	1	1	1	1
66	COIL - VALVE	ADS-25-1-HD-2	<a href="#">440355-01</a>	1	1	1	1	1
67	BOLT	-	<a href="#">440355F01</a>	1	1	1	1	1
	TRUSS HEAD SCREW	4X8	<a href="#">7C31-0408</a>	4	4	4	4	4
68	INSULATION TUBE	L=200	<a href="#">7762-1020</a>				1	1
69	INSULATION TUBE	L=100	<a href="#">7762-1020</a>				1	1

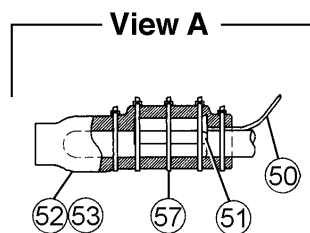
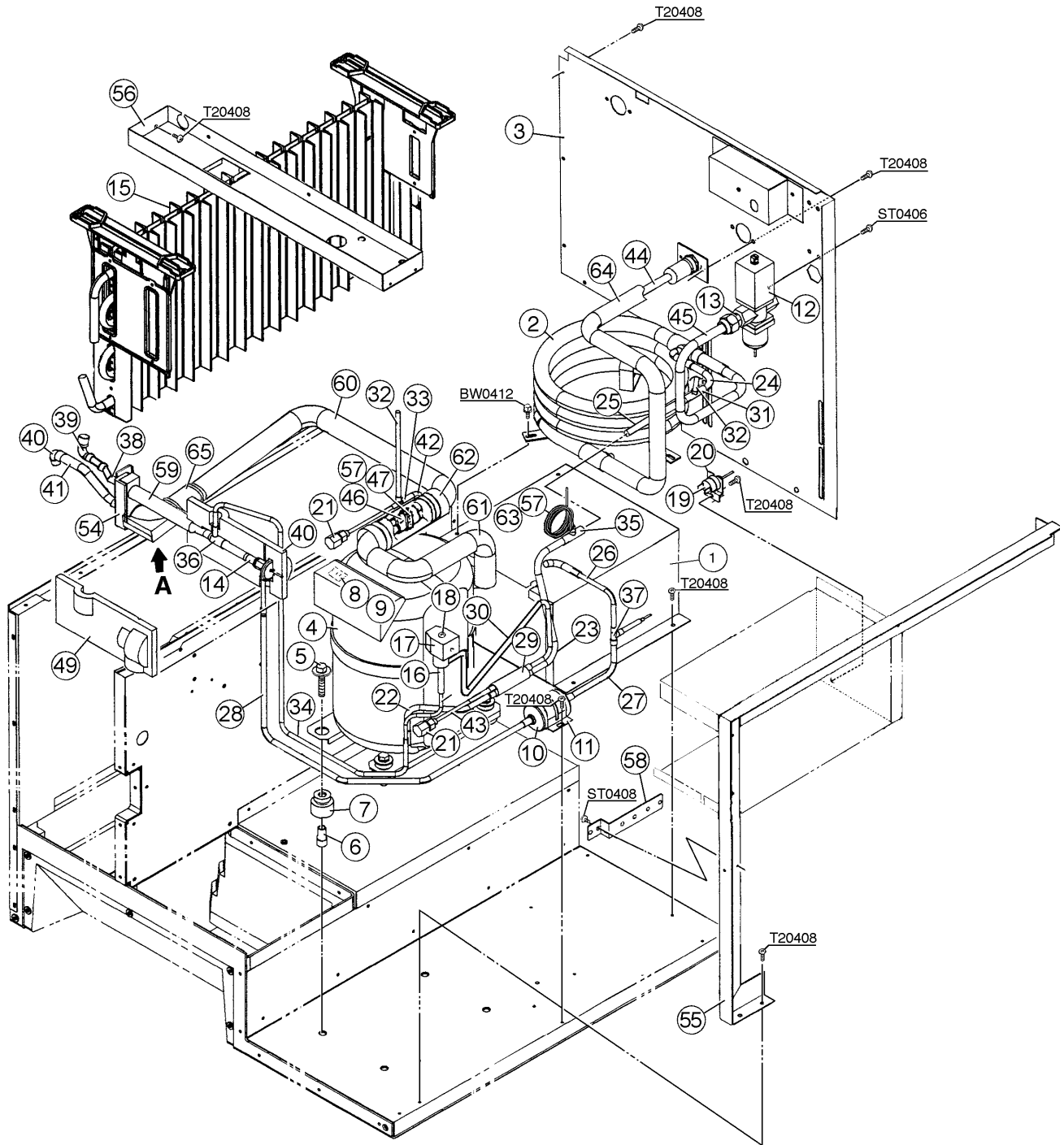

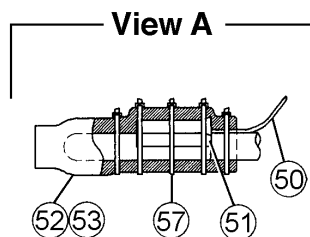
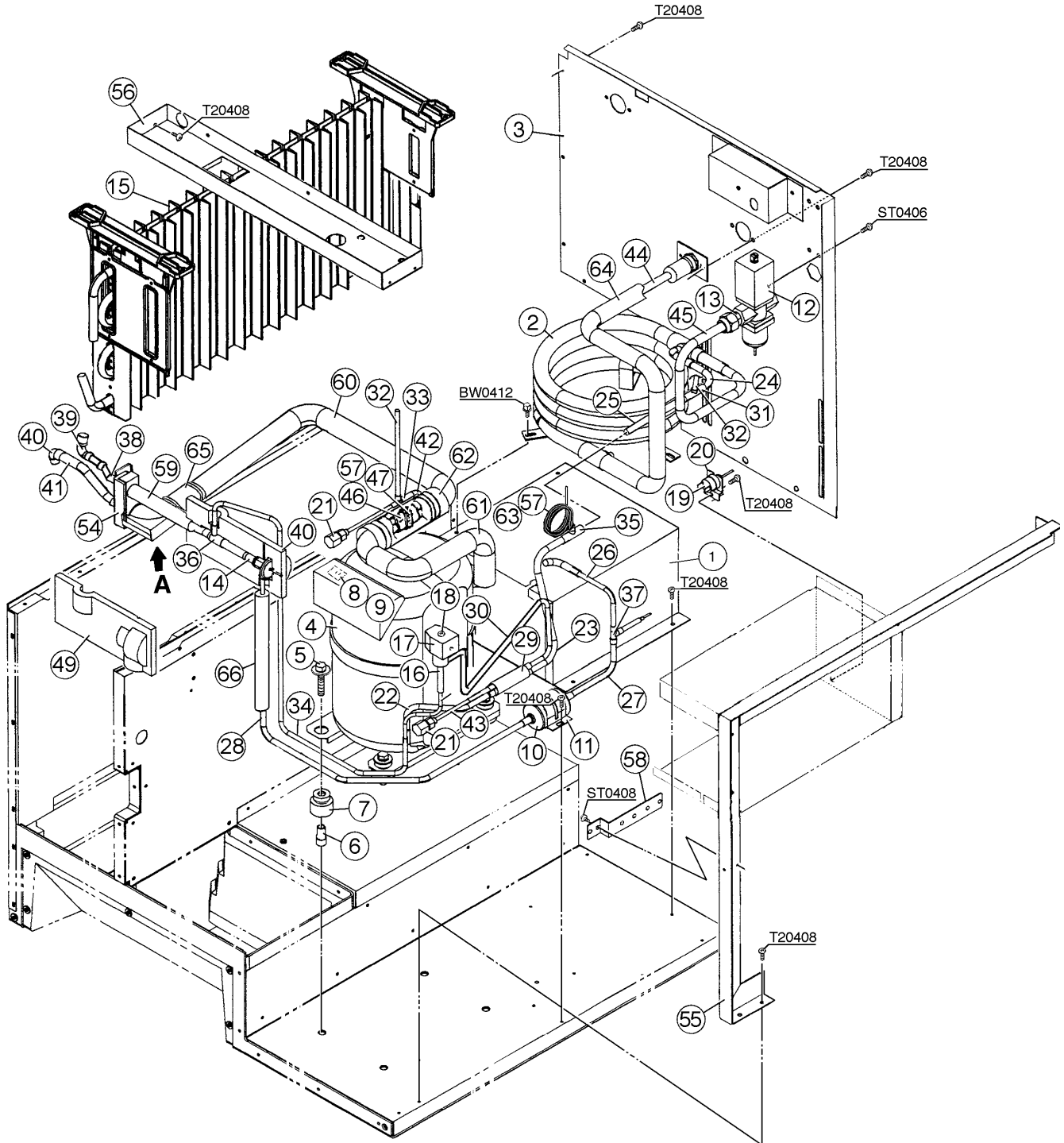

MODEL: <b>KML-200MWE</b> TITLE: <b>B. REFRIGERATION CIRCUIT</b>								
INDEX NO.	DESCRIPTION	MATERIAL OR MODEL NUMBER	PART NUMBER	REQUIRED NUMBER				
				G-0	H-0	H-1	H-2	J-0 K-0
1	CONDENSER SUPPORT	GS	2A0655-01	1	1	1	1	1
	T2 SCREW	4X8	7P31-0408	4	4	4	4	4
2	CONDENSER - WATER COOLED	S-0799	215544G02	1	1	1	1	1
	HEX HEAD BOLT W/WASHER (LF)	4X12	7B0130412	3	3	3	3	3
3	REAR PANEL (B)	GS	3A0630G01	1	1	1	1	1
	T2 SCREW	4X8	7P31-0408	9	9	9	9	9
4	COMPRESSOR	RSU4-0050-CAA	436634-01	1	1	1	1	1
5	BOLT	8 x 45	437889-01	4	4	4	4	4
6	SPACER	027-0072-02	434404-01	4	4	4	4	4
7	GROMMET	527-0039-04	434403-01	4	4	4	4	4
8	MOTOR PROTECTOR	071-0370-30	437340-01	1	1	1	1	1
9	PROTECTOR HOLDER	SS	437339-01	1	1	1	1	1
10	DRIER	C-0325-S	445007-01	1	1	1	1	1
11	DRIER BRACKET	GS	4A0807-01	1	1	1	1	1
	T2 SCREW	4X8	7P31-0408	2	2	2	2	2
12	WATER REGULATOR	-	4A0911-01	1	1	1	1	1
	TRUSS HEAD SCRW	4X6	7C31-0406	2	2	2	2	2
13	MALE CONNECTOR	BRASS	4A1087-01	1	1	1	1	1
14	EXPANSION VALVE	HFE-5HHD-2	446461-01	1	1	1	1	1
15	EVAPORATOR ASSEMBLY	-	2A0775G01	1	1	1	1	1
	T2 SCREW	4X16, SS	7P32-0416	4	4	4	4	4
16	VALVE BODY	24	440351-01	1	1	1	1	1
17	COIL - VALVE	ADS-24HD-2	440355-01	1	1	1	1	1
18	BOLT	-	440355F01	1	1	1	1	1
	TRUSS HEAD SCRW	4X8	7C31-0408	2	2	2	2	2
19	PRESSURE SWITCH	ACB-2UB02	433441-01	1	1	1	1	1
20	PRESSURE SWITCH BRCKT.	GS	434938-01	1	1	1	1	1
	T2 SCREW	4X8	7P31-0408	1	1	1	1	1
21	ACCESS VALVE	TCJ-2F15-HD	417366-01	2	2	2	2	2

MODEL: <b>KML-200MWE</b> TITLE: <b>B. REFRIGERATION CIRCUIT</b>								
INDEX NO.	DESCRIPTION	MATERIAL OR MODEL NUMBER	PART NUMBER	REQUIRED NUMBER				
				G-0	H-0	H-1	H-2	J-0 K-0
22	COPPER TUBE (A) - HIGH SIDE	COPPER	4A0986-01	1	1	1	1	1
23	COPPER TUBE (B) - HIGH SIDE	COPPER	4A0988-01	1	1	1	1	1
24	COPPER TUBE (C) - HIGH SIDE	COPPER	4A0990-01	1	1	1	1	1
25	COPPER TUBE (C1) - HIGH SIDE	COPPER	4A1334-01	1	1	1	1	1
26	COPPER TUBE (D1) - HIGH SIDE	COPPER	4A1000-01	1	1	1	1	1
27	COPPER TUBE (D2) - HIGH SIDE	COPPER	4A0992-01	1	1	1	1	1
28	COPPER TUBE (E) - HIGH SIDE	COPPER	3A0628-01	1	1	1	1	1
29	STRAINER	-	<a href="#">4A0397-01</a>	1	1	1	1	1
30	COPPER TUBE (A) - HOT GAS	COPPER	3A0770-01	1	1	1	1	1
31	TEE	COPPER	436000-06	1	1	1	1	1
32	EVACUATION TUBE	COPPER	4A1212-01	2	2	2	2	2
33	TEE	COPPER	436000-13	1	1	1	1	1
34	COPPER TUBE (B) - HOT GAS	COPPER	2A0832-01	1	1	1	1	1
35	TEE	COPPER	<a href="#">431618-01</a>	1	1	1	1	1
36	TEE	COPPER	<a href="#">436000-08</a>	1	1	1	1	1
37	TEE	COPPER	436000-05	1	1	1	1	1
38	COPPER TUBE (A) - LOW SIDE	COPPER	4A1183-01	1	1	1	1	1
39	ELBOW	COPPER	<a href="#">4A1059-01</a>	1	1	1	1	1
40	ELBOW	COPPER	<a href="#">417395-03</a>	1	1	1	1	1
41	COPPER TUBE - LOW SIDE	COPPER	2A0682-01	1	1	1	1	1
42	COPPER TUBE (A) - ACCESS VALVE	COPPER	4A1009-01	1	1	1	1	1
43	COPPER TUBE (B) - ACCESS VALVE	COPPER	4A1010-01	1	1	1	1	1
44	COPPER TUBE (A)	COPPER	3A0626G01	1	1	1	1	1
	T2 SCREW	4X8	<a href="#">7P32-0408</a>	2	2	2	2	2
45	COPPER TUBE (B)	COPPER	3A0627G01	1	1	1	1	1
46	HOLDER / EXPANSION VALVE - 3/8	SS	<a href="#">3A0107-01</a>	1	1	1	1	1
47	CLAMP	SS	<a href="#">443461-02</a>	1	1	1	1	1
48	EXPANSION VALVE COVER (A)	PE FOAM	<a href="#">322621-01</a>	1	1	1	1	1
49	EXPANSION VALVE COVER (B)	PE FOAM	<a href="#">322621-02</a>	1	1	1	1	1

MODEL: <b>KML-200MWE</b> TITLE: <b>B. REFRIGERATION CIRCUIT</b>								
INDEX NO.	DESCRIPTION	MATERIAL OR MODEL NUMBER	PART NUMBER	REQUIRED NUMBER				
				G-0	H-0	H-1	H-2	J-0 K-0
50	THERMISTOR	-	<a href="#">429006-03</a>	1	1	1	1	1
51	HOLDER - THERMISTOR	COPPER	<a href="#">427430-01</a>	1	1	1	1	1
52	INSULATION - THERMISTOR (A)	PE FOAM	<a href="#">439368-01</a>	1	1	1	1	1
53	INSULATION - THERMISTOR (B)	PE FOAM	<a href="#">439368-02</a>	1	1	1	1	1
54	INSULATED RUBBER TUBE	EPDM	<a href="#">4A1008G01</a>	1	1	1	1	1
55	FRAME (A)	GS	<a href="#">2A0645-01</a>	1	1	1	1	1
	T2 SCREW	4X8	<a href="#">7P32-0408</a>	4	4	4	4	4
56	FRAME (B)	GS	<a href="#">3A0595-01</a>	1	1	1	1	1
	T2 SCREW	4X8	<a href="#">7P32-0408</a>	4	4	4	4	4
57	CABLE TIE	CV-200	7920-0010	15	15	15	15	15
58	LINE VALVE BRACKET	GS	<a href="#">438213-01</a>	1	1	1	1	1
59	INSULATION TUBE	L=110	<a href="#">7762-1030</a>	1	1	1	1	x1
		L=140	<a href="#">7762-1030</a>					o1
60	INSULATION TUBE	L=580	<a href="#">7762-1330</a>	1	1	1	1	1
61	INSULATION TUBE	L=330	<a href="#">7762-1330</a>	1	1	1	1	1
62	INSULATION TUBE	L=140	<a href="#">7762-2943</a>	1	1	1	1	1
63	INSULATION TUBE	L=30	<a href="#">7762-1020</a>	3	3	3	3	3
64	INSULATION TUBE	L=670	<a href="#">7762-1323</a>	1	1	1	1	1
65	INSULATION TUBE	L=60	<a href="#">7762-2943</a>	1	1	1	1	1
66	INSULATION TUBE	L=100	<a href="#">7762-1020</a>				2	2



HA

KML-200MAE, MWE

C. WATER CIRCUIT

G-0, H-0, H-1

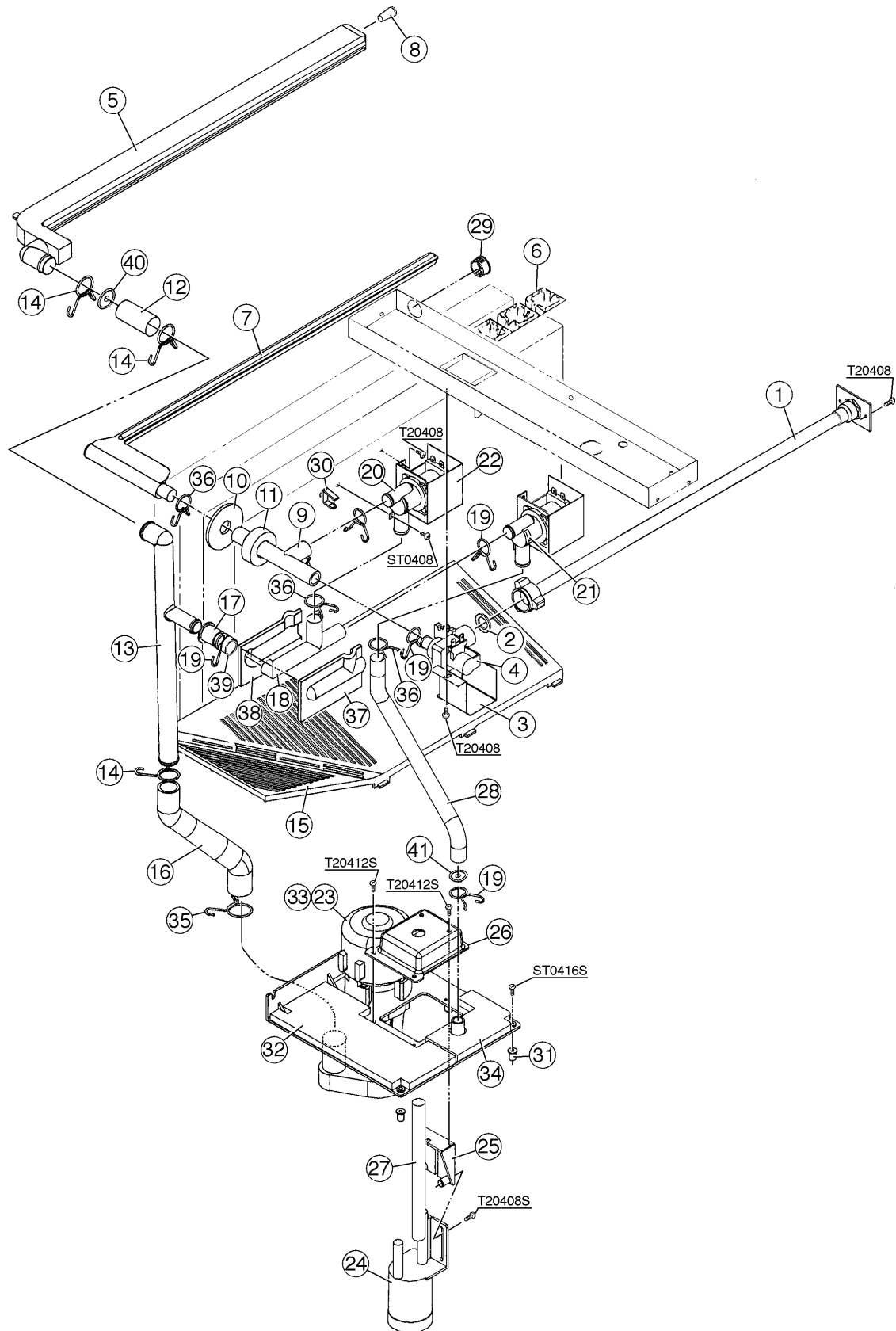

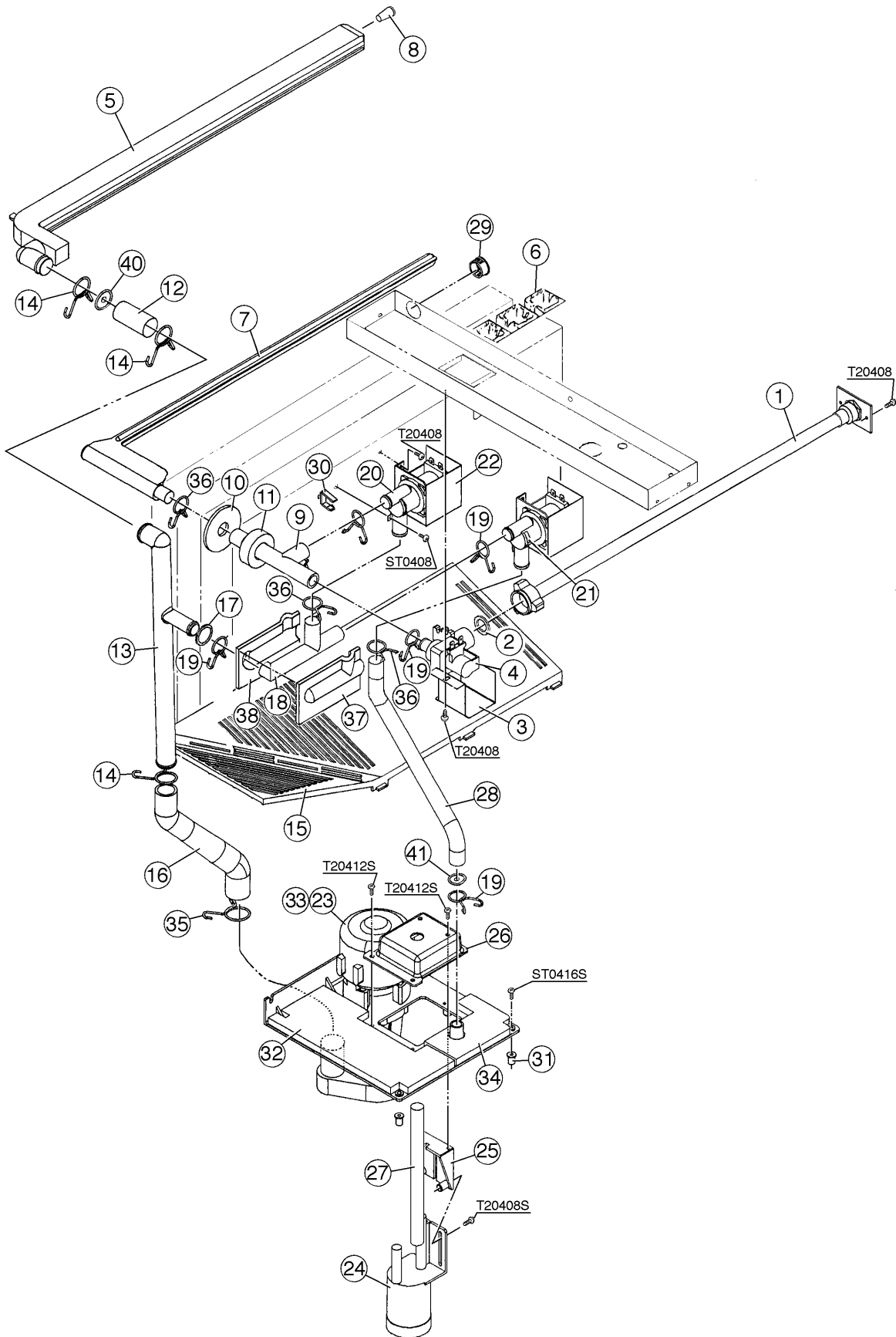

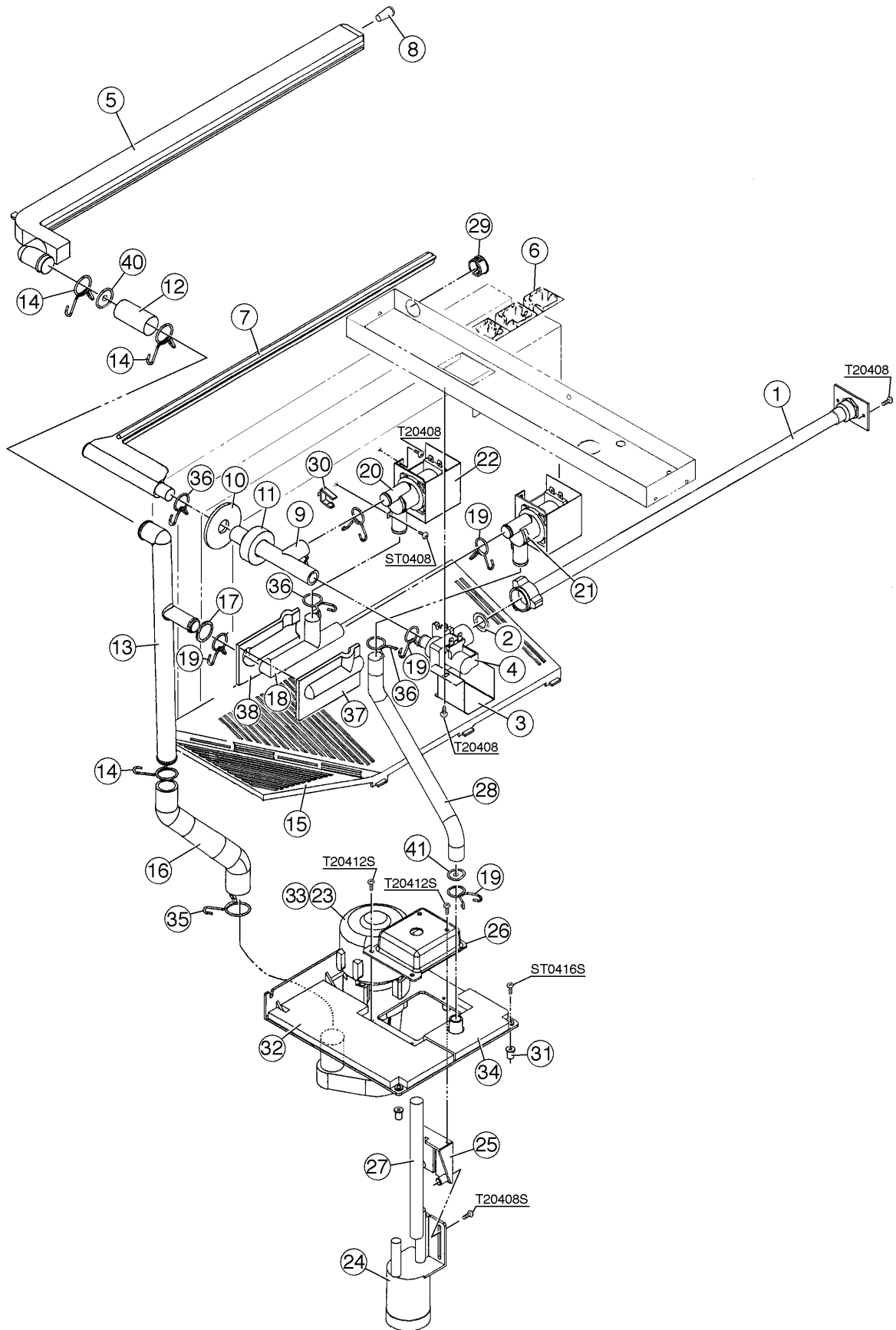

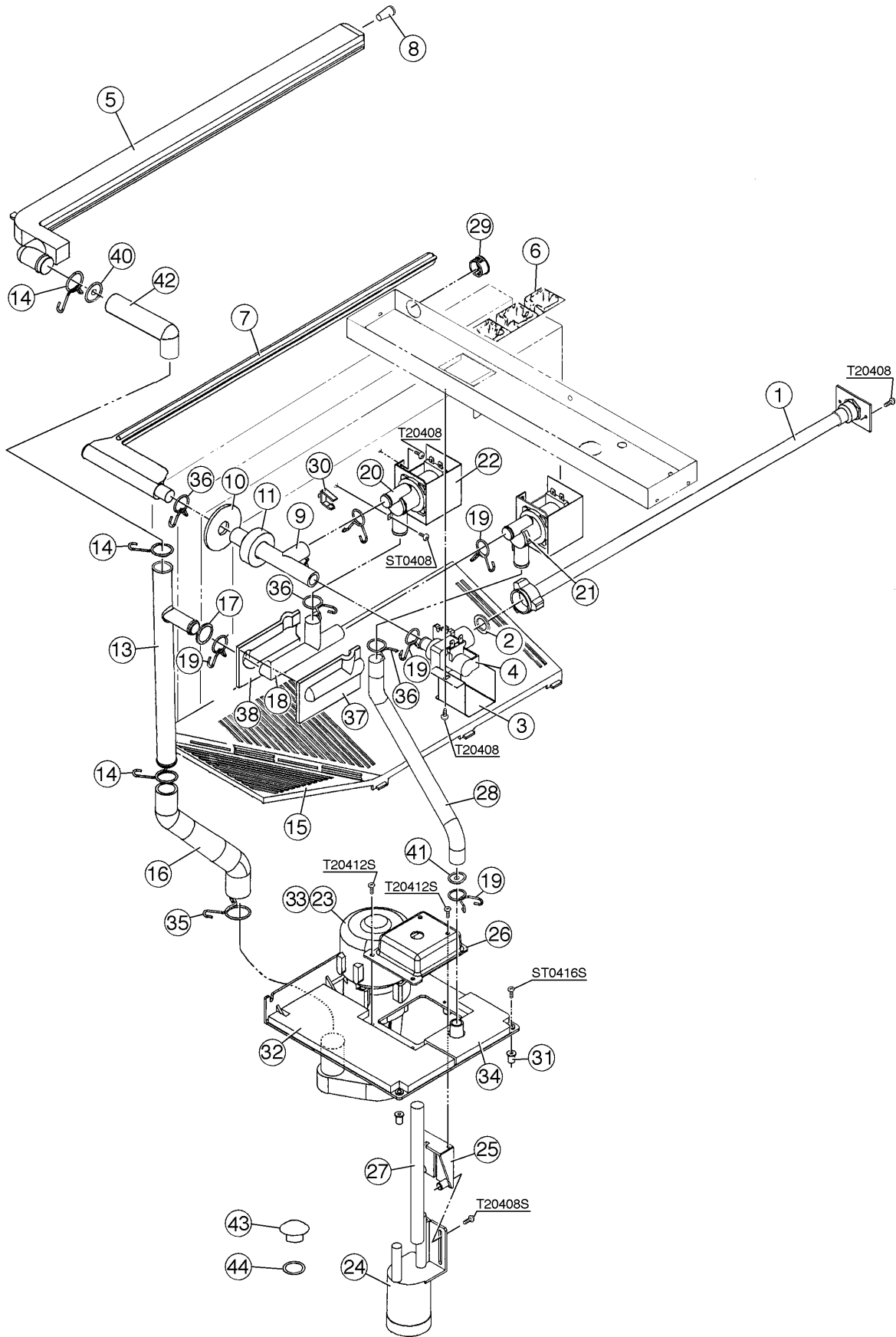

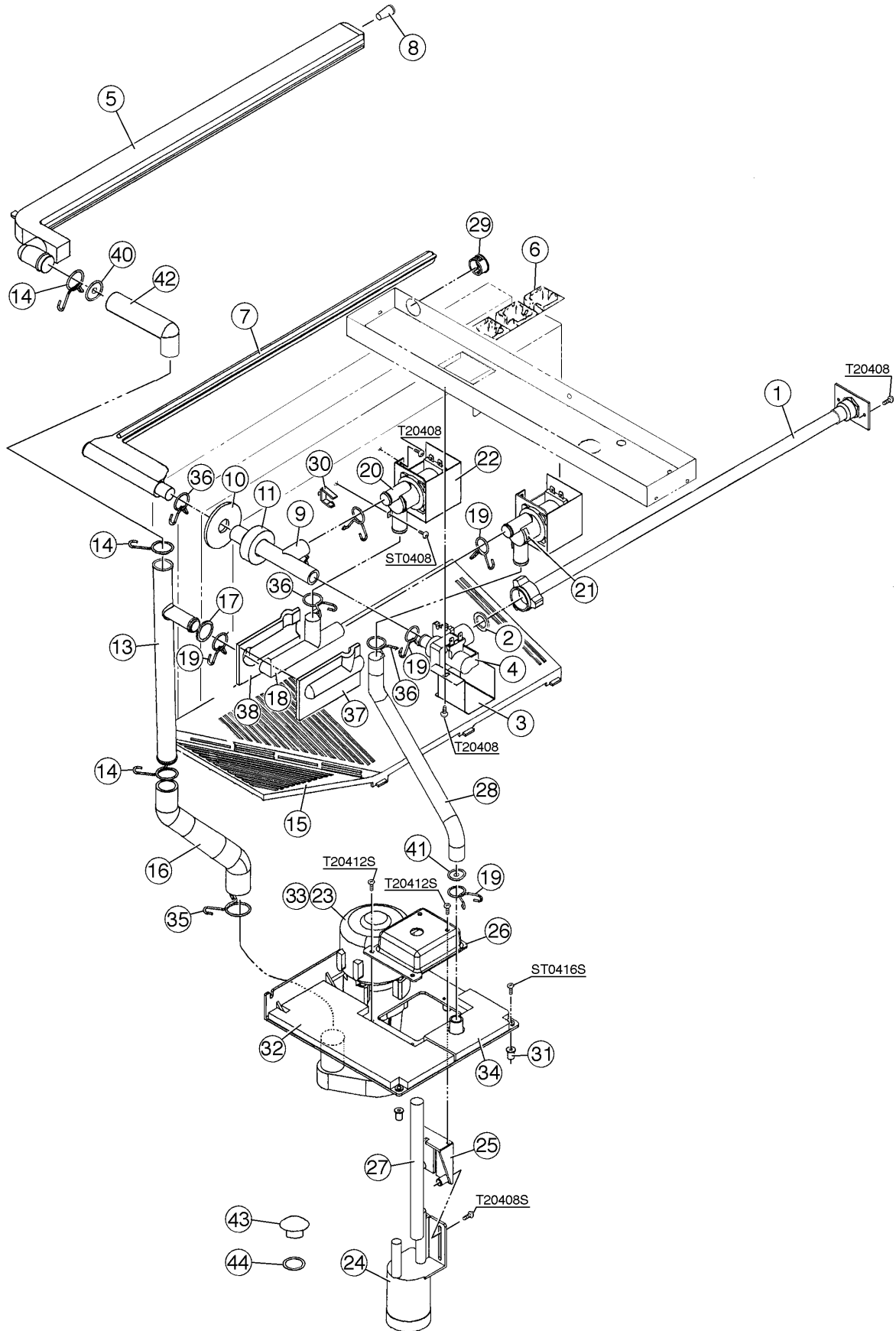

MODEL: <b>KML-200MAE</b> TITLE: <b>C. WATER CIRCUIT</b>								
INDEX NO.	DESCRIPTION	MATERIAL OR MODEL NUMBER	PART NUMBER	REQUIRED NUMBER				
				G-0	H-0	H-1	H-2	J00786C- J00636M- J00785B J01485L K-0
1	WATER SUPPLY PIPE	COPPER	4A0768G01	1	1	1	1	-
		COPPER	4A0768G04					1
	T2 SCREW	4X8	7P31-0408	2	2	2	2	2
2	RUBBER GASKET	NR	413854-03	1	1	1	1	1
3	WATER VALVE BRACKET	GS	321443-01	1	1	1	1	1
	T2 SCREW	4X8	7P31-0408	1	1	1	1	1
4	WATER VALVE	J248-647	3U0150-01	1	1	1	1	1
5	SPRAY TUBE	PE	1A0133-02	1	x1	1	1	1
		PE	1A0222-02		o1	1	1	1
6	SPRAY GUIDE (A)	PE	208586-01	6	6	6	6	6
7	WATER SUPPLY TUBE	PE	2A0560-01	1	1	1	1	1
8	PLUG	EPDM	4A0176-01	1	1	1	1	1
9	WATER SUPPLY TEE	SANTOPRENE	4A1006-01	1	1	1	1	1
10	FLANGE	EPDM	439267-01	1	1	1	1	1
11	INSULATION (E)	PE FOAM	4A0392-01	1	1	1	1	1
12	VINYL HOSE	L=50	7716-2025	1	1	1	1	-
13	CONNECTING PIPE	PE	3A0611-01	1	1	1	1	-
		-	3A1335-01					1
14	HOSE CLAMP	SS, 25 mm	427443-03	3	3	3	3	3
15	CUBE GUIDE (A)	ABS	2A0660-01	1	1	1	1	1
16	PUMP HOSE	EPDM	4A1007-01	1	1	1	1	1
17	RUBBER RING	SANTOPRENE	4A1004-01	1	1	1	1	1
18	BYPASS HOSE	SANTOPRENE	4A1005-01	1	1	1	1	1
19	HOSE CLAMP	SS, 18 mm	427443-05	5	5	5	5	5
20	SOLENOID VALVE	207CB-GS1873	439322-01	2	2	2	2	2
	TRUSS HEAD SCREW	4X8	7C31-0408	2	2	2	2	2
21	ARROW LABEL	PES	4A0096-01	1	1	1	1	1
24	FLOAT SWITCH	163795	4A0886-01	1	1	1	1	1

MODEL: <b>KML-200MAE</b> TITLE: <b>C. WATER CIRCUIT</b>								
INDEX NO.	DESCRIPTION	MATERIAL OR MODEL NUMBER	PART NUMBER	REQUIRED NUMBER				
				G-0	H-0	H-1	H-2	J00786C- J00636M- J00785B J01485L K-0
22	SOLENOID COVER	GS	4A0996-01	2	2	2	2	2
	T2 SCREW	4X8	7P31-0408	4	4	4	4	4
23	PUMP	-	2A0749-01	1	1	1	1	1
	TRUSS HEAD SCREW	4X8, SS	7C32-0408	4	4	4	4	4
24	FLOAT SWITCH	163795	4A0886-01	1	1	1	1	1
25	FLOAT SWITCH BRACKET	ABS	327757-01	1	1	1	1	1
	T2 SCREW	4X12, SS	7P32-0412	2	2	2	2	2
26	FLOAT SWITCH COVER	ABS	3A0665-01	1	1	1	1	1
	T2 SCREW	4X12, SS	7P32-0412	3	3	3	3	3
27	VINYL HOSE	L=150	7716-1216	1	1	1	1	1
28	SILICONE HOSE	L=275	7730-1519	1	1	1	1	1
29	BUSHING	OCB-875	428394-04	1	1	1	1	1
30	WIRE SADDLE	VWS4238-C	4A0338-02	8	8	8	8	8
31	WELL NUT	347011	4A1070-01	2	2	2	2	2
32	INSULATION (A) - PUMP BRACKET	PE FOAM	4A1052-01	1	1	1	1	1
33	TOOTH WASHER	ZINC, M4	7R21-0400	1	1	1	1	1
	T2 SCREW	4X8	7P31-0408	1	1	1	1	1
34	INSULATION (B) - PUMP BRACKET	PE FOAM	4A1053-01	1	1	1	1	1
35	HOSE CLAMP	SS, 27 mm	427443-08	1	1	1	1	1
36	HOSE CLAMP	SS, 20 mm	427443-06	3	3	3	3	3
37	BYPASS HOSE INSULATION (A1)	NP	4A1259-01	1	1	1	1	1
38	BYPASS HOSE INSULATION (A2)	NP	4A1260-01	1	1	1	1	1
39	INSULATION HOSE	L=25	7762-2030	1	1	1	-	
40	RESTRICTION WASHER	ABS	4A1148-01	1	1	1	1	1
41	DRAIN RESTRICTOR	ABS	4A1198-01	1	1	1	1	1
42	ELBOW	-	4A0393-01					1
43	DRAIN	-	309246-01					1
44	O-RING	-	7611-P015					1

MODEL: KML-200MWE TITLE: C. WATER CIRCUIT								
INDEX NO.	DESCRIPTION	MATERIAL OR MODEL NUMBER	PART NUMBER	REQUIRED NUMBER				
				G-0	H-0	H-1	H-2	J00296D- J00196M- J00295B J00425J K-0
1	WATER SUPPLY PIPE	COPPER	4A0768G01	1	1	1	1	-
		COPPER	4A0768G04					1
	T2 SCREW	4X8	7P31-0408	2	2	2	2	2
2	RUBBER GASKET	NR	413854-03	1	1	1	1	1
3	WATER VALVE BRACKET	GS	321443-01	1	1	1	1	1
	T2 SCREW	4X8	7P31-0408	1	1	1	1	1
4	WATER VALVE	J248-647	3U0150-01	1	1	1	1	1
5	SPRAY TUBE	PE	1A0133-02	1	x1	1	1	1
		PE	1A0222-02		o1	1	1	1
6	SPRAY GUIDE (A)	PE	208586-01	6	6	6	6	6
7	WATER SUPPLY TUBE	PE	2A0560-01	1	1	1	1	1
8	PLUG	EPDM	4A0176-01	1	1	1	1	1
9	WATER SUPPLY TEE	SANTOPRENE	4A1006-01	1	1	1	1	1
10	FLANGE	EPDM	439267-01	1	1	1	1	1
11	INSULATION (E)	PE FOAM	4A0392-01	1	1	1	1	1
12	VINYL HOSE	L=50	7716-2025	1	1	1	1	-
13	CONNECTING PIPE	PE	3A0611-01	1	1	1	1	-
		-	3A1335-01					1
14	HOSE CLAMP	SS, 25 mm	427443-03	3	3	3	3	3
15	CUBE GUIDE (A)	ABS	2A0660-01	1	1	1	1	1
16	PUMP HOSE	EPDM	4A1007-01	1	1	1	1	1
17	RUBBER RING	SANTOPRENE	4A1004-01	1	1	1	1	1
18	BYPASS HOSE	SANTOPRENE	4A1005-01	1	1	1	1	1
19	HOSE CLAMP	SS, 18 mm	427443-05	5	5	5	5	5
20	SOLENOID VALVE	207CB-GS1873	439322-01	2	2	2	2	2
	TRUSS HEAD SCREW	4X8	7C31-0408	2	2	2	2	2
21	ARROW LABEL	PES	4A0096-01	1	1	1	1	1
24	FLOAT SWITCH	163795	4A0886-01	1	1	1	1	1



MODEL: <b>KML-200MWE</b> TITLE: <b>C. WATER CIRCUIT</b>								
INDEX NO.	DESCRIPTION	MATERIAL OR MODEL NUMBER	PART NUMBER	REQUIRED NUMBER				
				G-0	H-0	H-1	H-2	J00296D- J00196M- J00295B J00425J K-0
22	SOLENOID COVER	GS	4A0996-01	2	2	2	2	2
	T2 SCREW	4X8	7P31-0408	4	4	4	4	4
23	PUMP	-	2A0749-01	1	1	1	1	1
	TRUSS HEAD SCREW	4X8, SS	7C32-0408	4	4	4	4	4
24	FLOAT SWITCH	163795	4A0886-01	1	1	1	1	1
25	FLOAT SWITCH BRACKET	ABS	327757-01	1	1	1	1	1
	T2 SCREW	4X12, SS	7P32-0412	2	2	2	2	2
26	FLOAT SWITCH COVER	ABS	3A0665-01	1	1	1	1	1
	T2 SCREW	4X12, SS	7P32-0412	3	3	3	3	3
27	VINYL HOSE	L=150	7716-1216	1	1	1	1	1
28	SILICONE HOSE	L=275	7730-1519	1	1	1	1	1
29	BUSHING	OCB-875	428394-04	1	1	1	1	1
30	WIRE SADDLE	VWS4238-C	4A0338-02	8	8	8	8	8
31	WELL NUT	347011	4A1070-01	2	2	2	2	2
32	INSULATION (A) - PUMP BRACKET	PE FOAM	4A1052-01	1	1	1	1	1
33	TOOTH WASHER	ZINC, M4	7R21-0400	1	1	1	1	1
	T2 SCREW	4X8	7P31-0408	1	1	1	1	1
34	INSULATION (B) - PUMP BRACKET	PE FOAM	4A1053-01	1	1	1	1	1
35	HOSE CLAMP	SS, 27 mm	427443-08	1	1	1	1	1
36	HOSE CLAMP	SS, 20 mm	427443-06	3	3	3	3	3
37	BYPASS HOSE INSULATION (A1)	NP	4A1259-01	1	1	1	1	1
38	BYPASS HOSE INSULATION (A2)	NP	4A1260-01	1	1	1	1	1
39	INSULATION HOSE	L=25	7762-2030	1	1	1	-	
40	RESTRICTION WASHER	ABS	4A1148-01	1	1	1	1	1
41	DRAIN RESTRICTOR	ABS	4A1198-01	1	1	1	1	1
42	ELBOW	-	4A0393-01					1
43	DRAIN	-	309246-01					1
44	O-RING	-	7611-P015					1

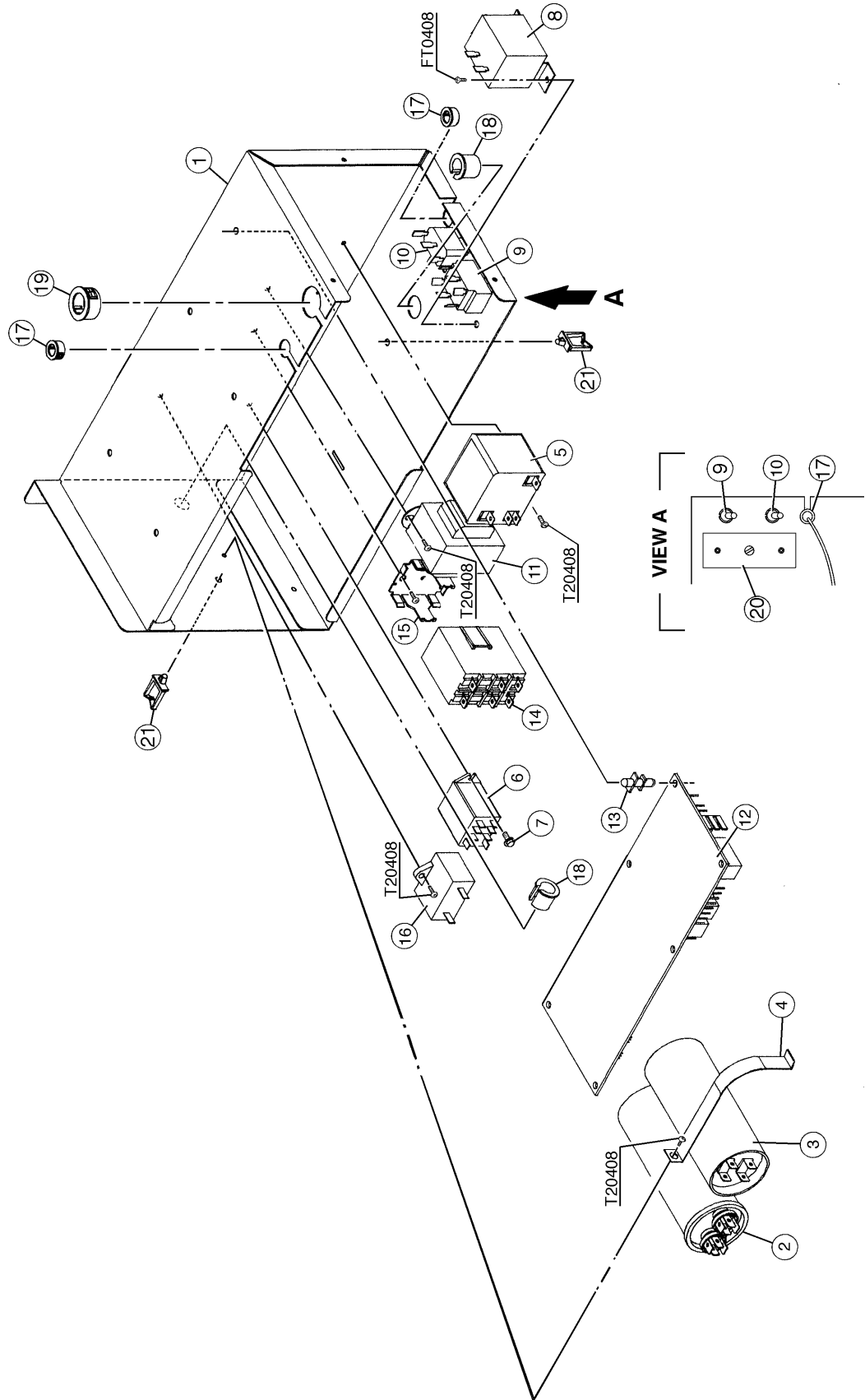

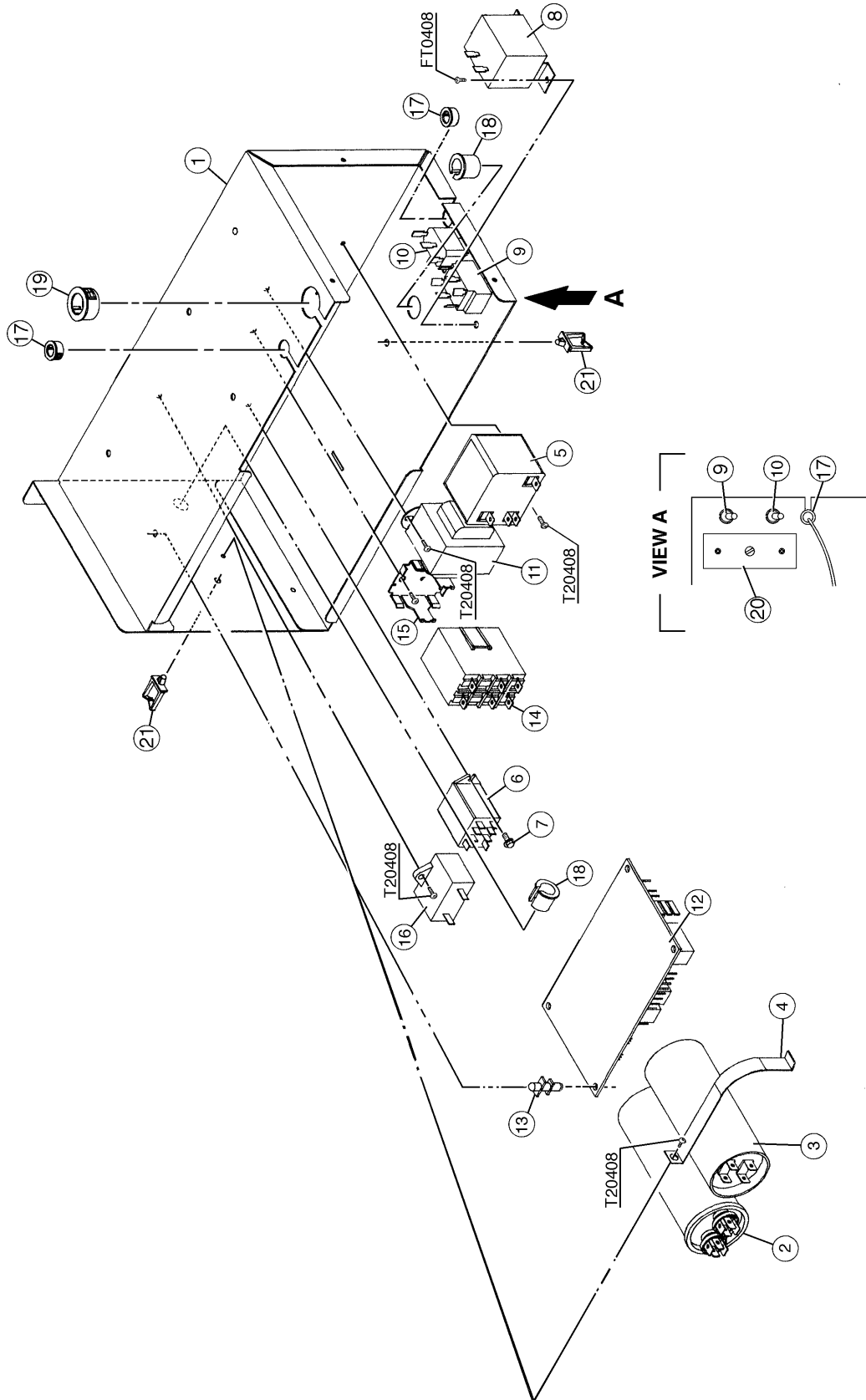

MODEL: <b>KML-200MAE</b> TITLE: <b>D. CONTROL BOX ASSEMBLY</b>								
INDEX NO.	DESCRIPTION	MATERIAL OR MODEL NUMBER	PART NUMBER	REQUIRED NUMBER				
				G-0 H-0	H-1	H-2	J-0	K-0
1	CONTROL BOX	GS	3A0602G01	1	1	1	1	1
2	CAPACITOR	15 $\bar{r}$ 370 VAC	439943-04	1	1	1	1	1
3	CAPACITOR - STARTING	270-324 $\bar{r}$ 25V	<a href="#">3A0076-04</a>	1	1	1	1	1
4	STRAP	GS	434580-10	1	1	1	x1	
		GS	434580-11				o1	1
	T2 SCREW	4X8	<a href="#">7P31-0408</a>	1	1	1	1	1
5	STARTER	040-0001-20	434923-01	1	1	1	1	x1
		-	<a href="#">4A1107-09</a>					o1
	T2 SCREW	4X8	<a href="#">7P31-0408</a>	1	1	1	1	1
6	RELAY	LY2F 120 VAC	<a href="#">406132-07</a>	1	1	1	1	1
7	TAPPING SCREW	3X8	<a href="#">431415-01</a>	2	2	2	2	2
8	THERMOSTAT	A30-3815-00	4A0824-01	1	1	1	1	1
	TRUSS HEAD SCREW	4X8	<a href="#">7C31-0408</a>	2	2	2	2	2
9	TOGGLE SWITCH	7563K6	<a href="#">443119-01</a>	1	1	1	1	1
10	TOGGLE SWITCH	8966K211	<a href="#">4A0985-01</a>	1	1	1	1	1
11	TRANSFORMER	26D285H	<a href="#">3A0172-01</a>	1	1	1	1	1
	T2 SCREW	4X8	<a href="#">7P31-0408</a>	2	2	2	2	2
12	CONTROLLER BOARD	MY9KM910	2U0127-01	1	-			
		HOSHIZAKI-001	2A0836-01		1	x1		
		-	<a href="#">2A1410-01</a>			o1	1	1
13	BOARD SUPPORT	CBLS37-M	<a href="#">4A0336-03</a>	6	4	6	6	4
14	MAGNETIC CONTACTOR	VC20	428393-01	1	1	1	1	1
15	BRACKET	BW 9154	428393F01	1	1	1	1	1
	T2 SCREW	4X8	<a href="#">7P31-0408</a>	2	2	2	2	2
16	CAPACITOR	5 $\bar{r}$ 250 VAC	<a href="#">443192-02</a>	1	1	1	1	1
	T2 SCREW	4X8	<a href="#">7P31-0408</a>	1	1	1	1	1
17	BUSHING	OCB-500	<a href="#">428394-02</a>	2	2	2	2	2

HA

MODEL: <b>KML-200MAE</b> TITLE: <b>D. CONTROL BOX ASSEMBLY</b>								
INDEX NO.	DESCRIPTION	MATERIAL OR MODEL NUMBER	PART NUMBER	REQUIRED NUMBER				
				G-0 H-0	H-1	H-2	J-0	K-0
18	BUSHING	OCB-625	428394-03	2	2	2	2	2
19	BUSHING	OCB-875	428394-04	1	1	1	1	1
20	CONTROL LABEL	PES FILM	434934-01	1	1	-		
		-	4A1758-01			1	1	1
21	WIRE SADDLE	VWS4238-C	4A0338-02	2	2	2	2	2

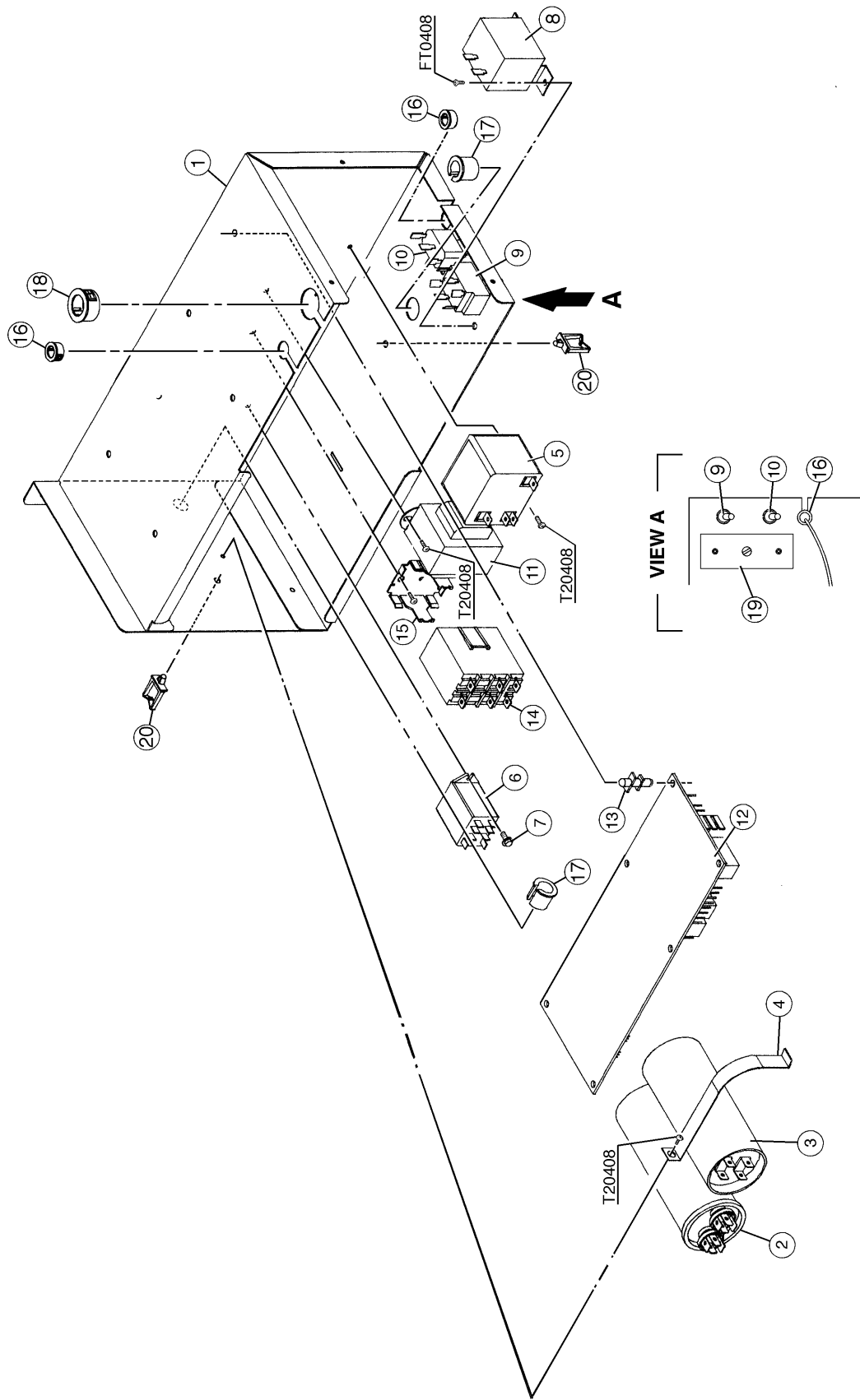

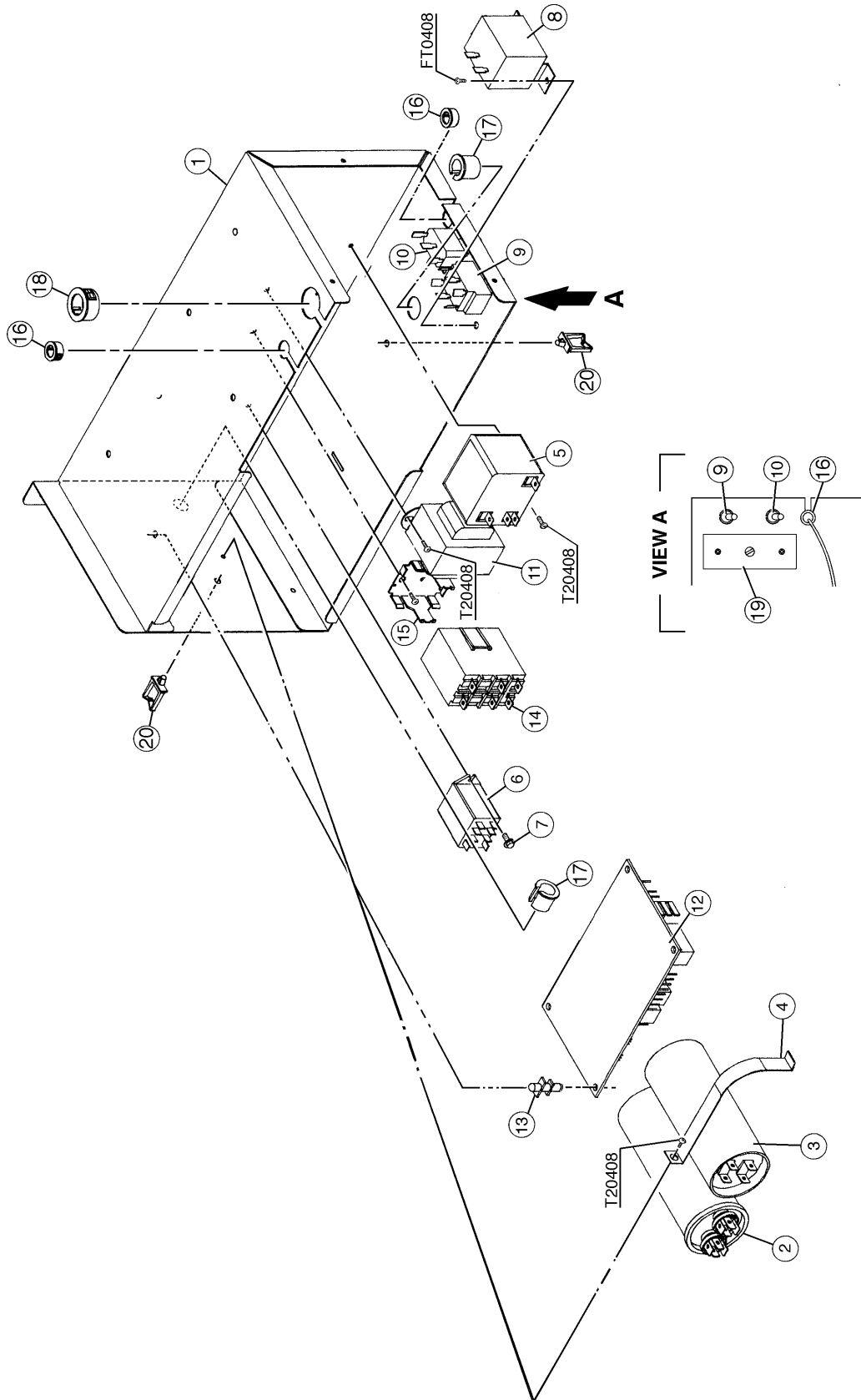

MODEL: KML-200MWE TITLE: D. CONTROL BOX ASSEMBLY								
INDEX NO.	DESCRIPTION	MATERIAL OR MODEL NUMBER	PART NUMBER	REQUIRED NUMBER				
				G-0 H-0	H-1	H-2	J-0	K-0
1	CONTROL BOX	GS	3A0602G01	1	1	1	1	1
2	CAPACITOR	157 370 VAC	439943-04	1	1	1	1	1
3	CAPACITOR - STARTING	270-3247 25V	3A0076-04	1	1	1	1	1
4	STRAP	GS	434580-10	1	1	1	x1	
		GS	434580-11				o1	1
	T2 SCREW	4X8	7P31-0408	1	1	1	1	1
5	STARTER	040-0001-20	434923-01	1	1	1	1	x1
		-						o1
	T2 SCREW	4X8	7P31-0408	1	1	1	1	1
6	RELAY	LY2F 120 VAC	406132-07	1	1	1	1	1
7	TAPPING SCREW	3X8	431415-01	2	2	2	2	2
8	THERMOSTAT	A30-3815-00	4A0824-01	1	1	1	1	1
	TRUSS HEAD SCREW	4X8	7C31-0408	2	2	2	2	2
9	TOGGLE SWITCH	7563K6	443119-01	1	1	1	1	1
10	TOGGLE SWITCH	8966K211	4A0985-01	1	1	1	1	1
11	TRANSFORMER	26D285H	3A0172-01	1	1	1	1	1
	T2 SCREW	4X8	7P31-0408	2	2	2	2	2
12	CONTROLLER BOARD	MY9KM910	2U0127-01	1	-			
		HOSHIZAKI-001	2A0836-01		1	1	1	x1
		-	2A1410-01					o1
13	BOARD SUPPORT	CBLS37-M	4A0336-03	6	4	6	6	4
14	MAGNETIC CONTACTOR	VC20	428393-01	1	1	1	1	1
15	BRACKET	BW9154	428393F01	1	1	1	1	1
	T2 SCREW	4X8	7P31-0408	2	2	2	2	2
16	BUSHING	OCB-500	428394-02	2	2	2	2	2
17	BUSHING	OCB-625	428394-03	2	2	2	2	2





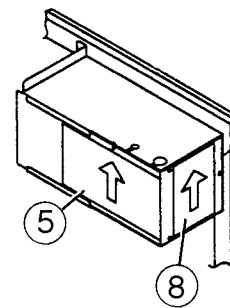
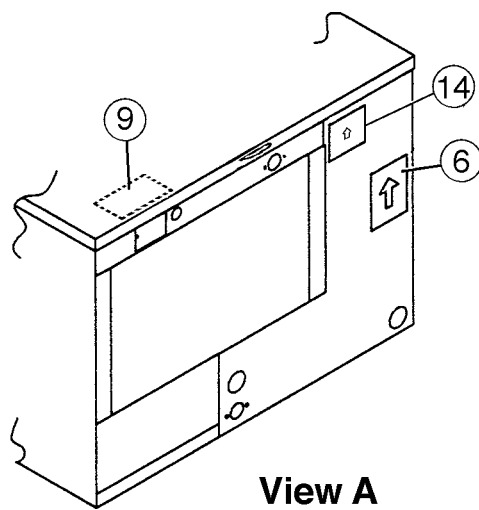
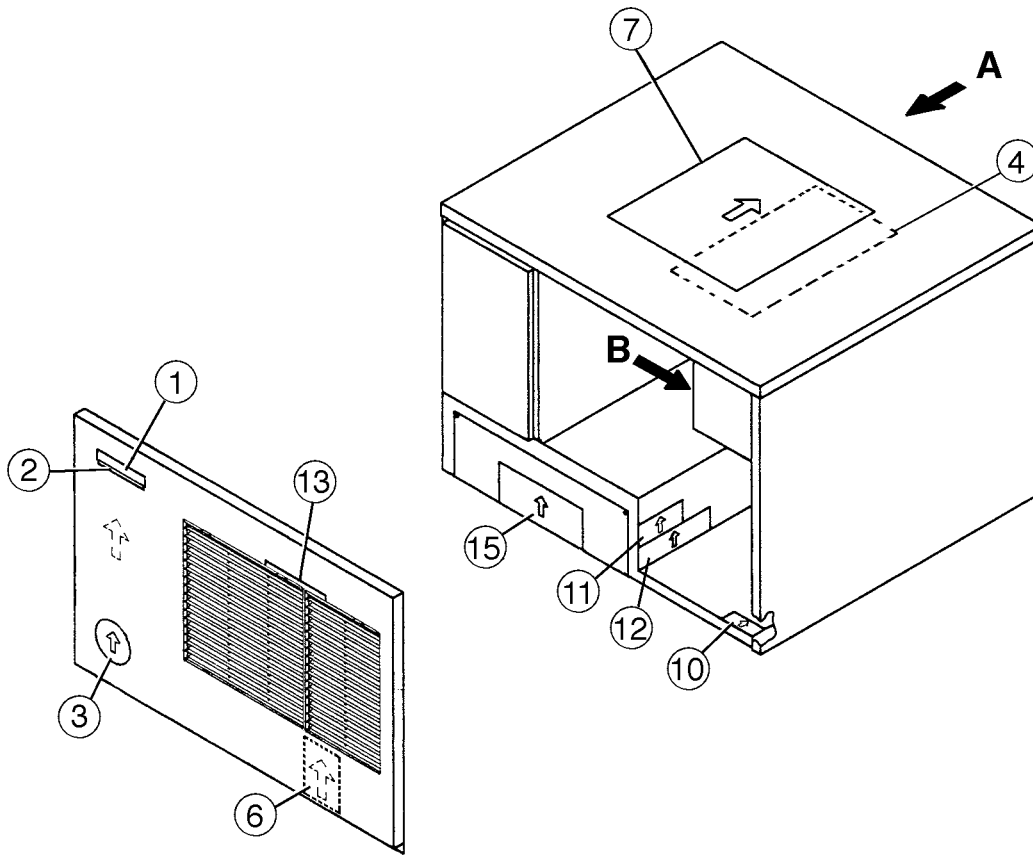

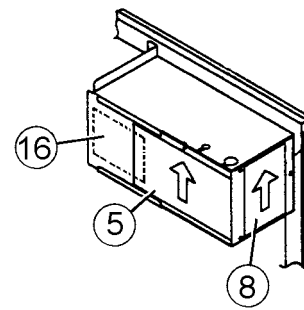
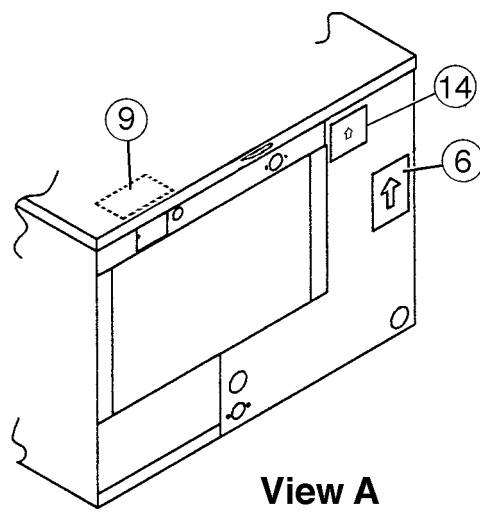
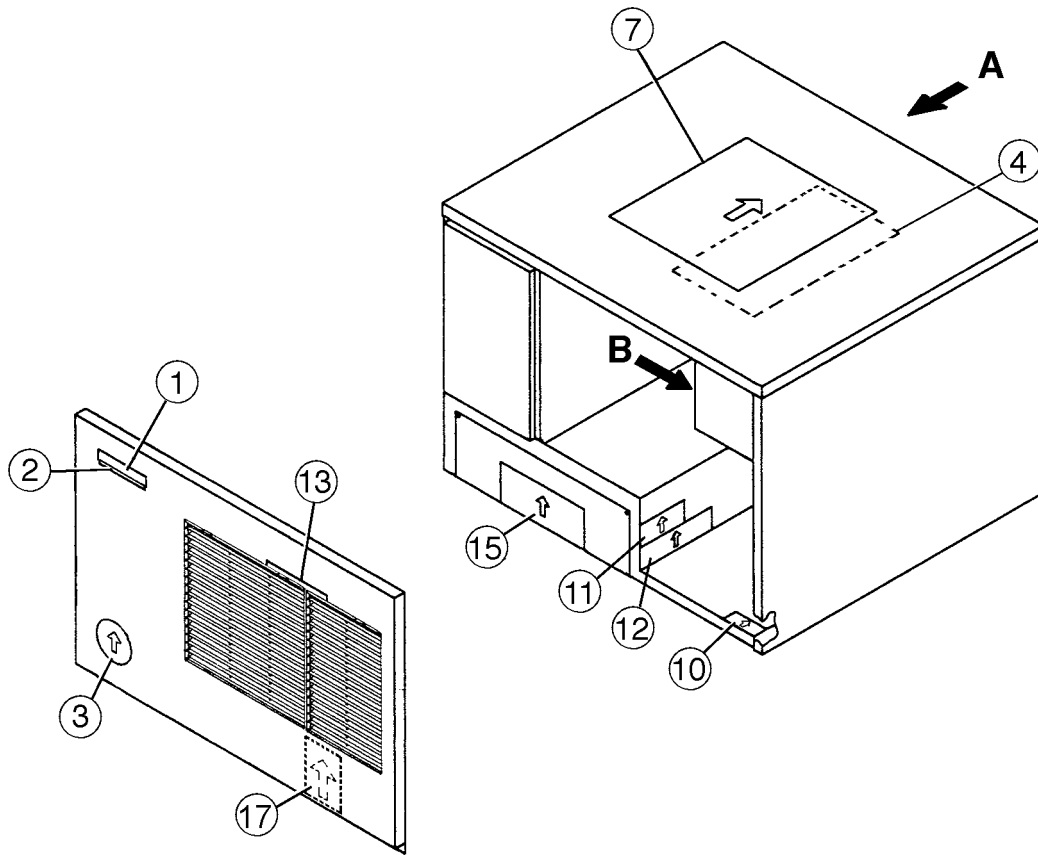

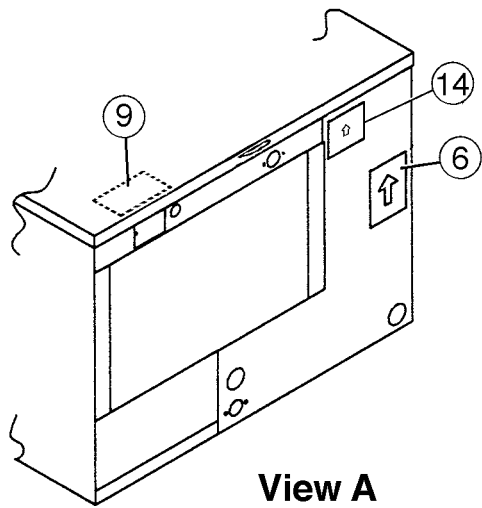
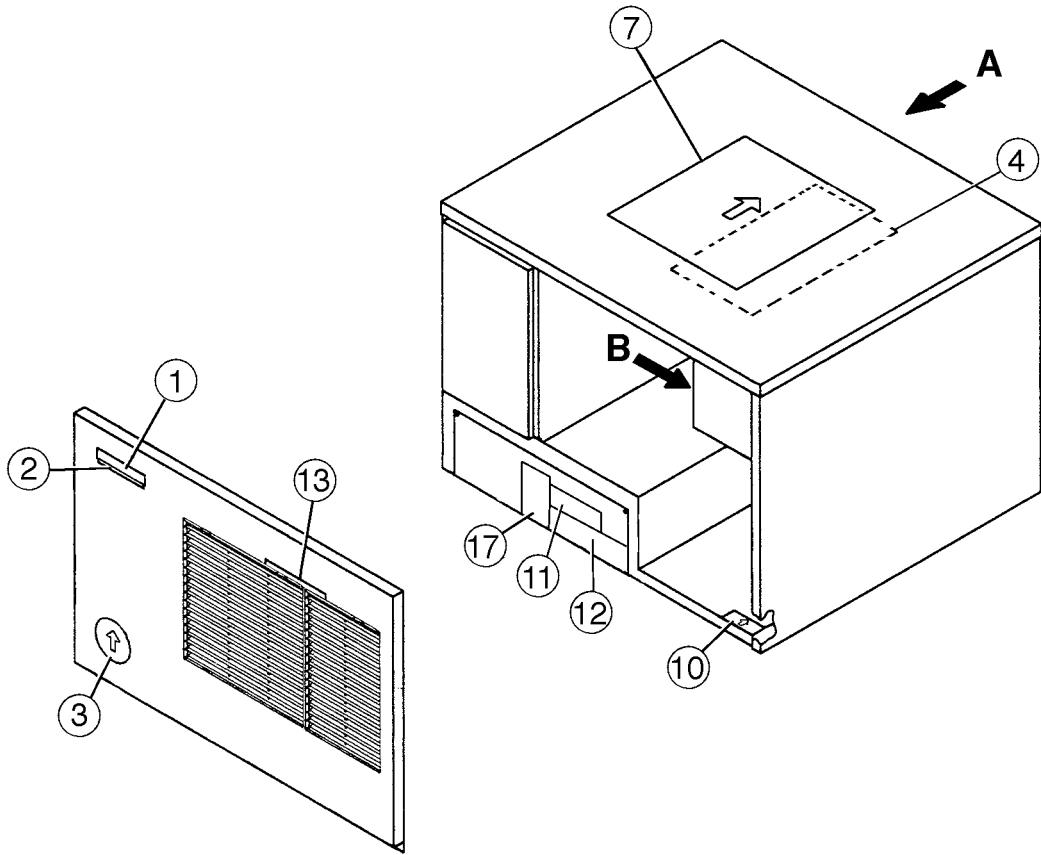

View A

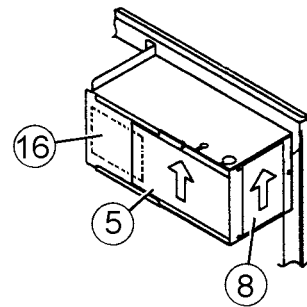

View B

HA

MODEL: <b>KML-200MAE</b> TITLE: <b>E. LABEL LOCATION</b>								
INDEX NO.	DESCRIPTION	MATERIAL OR MODEL NUMBER	PART NUMBER	REQUIRED NUMBER				
				G-0 H-0	H-1 H-2	J00636M- J00785B	J00786C- J01485L	K-0
1	EMBLEM	PETP FILM	4A0560-01	1	1	1	1	1
2	MODEL NUMBER LABEL	PETP FILM	443341-35	1	1	1	1	1
3	LABEL - PENGUIN - HA (R)	PETP FILM	4A0526-01	1	1	1	1	1
4	MAINTENANCE LABEL	PVC FILM	3A0878-01	1	1	1	1	1
5	WIRING LABEL	PVC FILM	3A0783-01	1	1	1	1	1
6	NAMEPLATE	PES FILM	4A1196-01	2	1	2	2	1
7	INSTRUCTION SHEET	PAPER	2A0750-01	1	1	1	-	
		PAPER	2A1253-01				1	1
8	MANUAL LABEL	PVC FILM	4A1090-01	1	1	1	1	1
9	TAG - WARNING: ELECTRICAL CONNECTION	PAPER	435005-01	1	1	1	1	1
10	LABEL - R22	PES FILM	440362-01	1	1	1	1	1
11	CAUTION LABEL (F)	PVC FILM	439146-01	1	1	1	1	1
12	CAUTION LABEL (K)	PVC FILM	439150-01	1	1	1	1	1
13	LABEL - AIR FILTER	PETP FILM	426177-01	1	1	1	1	1
14	INSTRUCTION LABEL	PVC FILM	444575-01	1	1	1	1	1
15	WARNING LABEL - MANUAL FILL	PVC FILM	4A1091-01	1	1	1	-	
16	LABEL – CONTROL BOARD	PVC FILM	3A0998-01		1	1	1	-
		PVC FILM	3A1272-01					1
17	RATING LABEL	PES FILM	4A1609-01		1	1	1	1

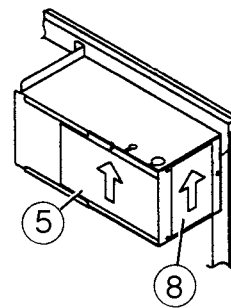
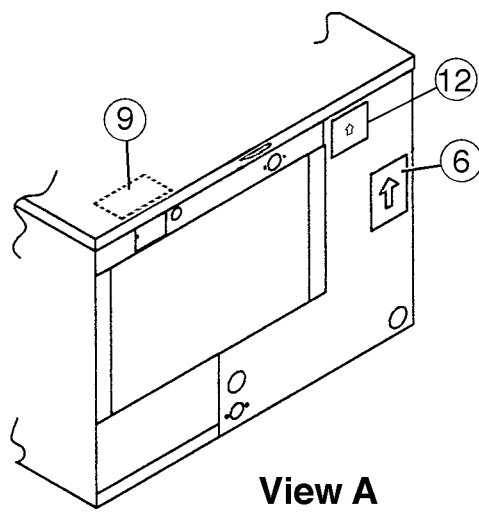
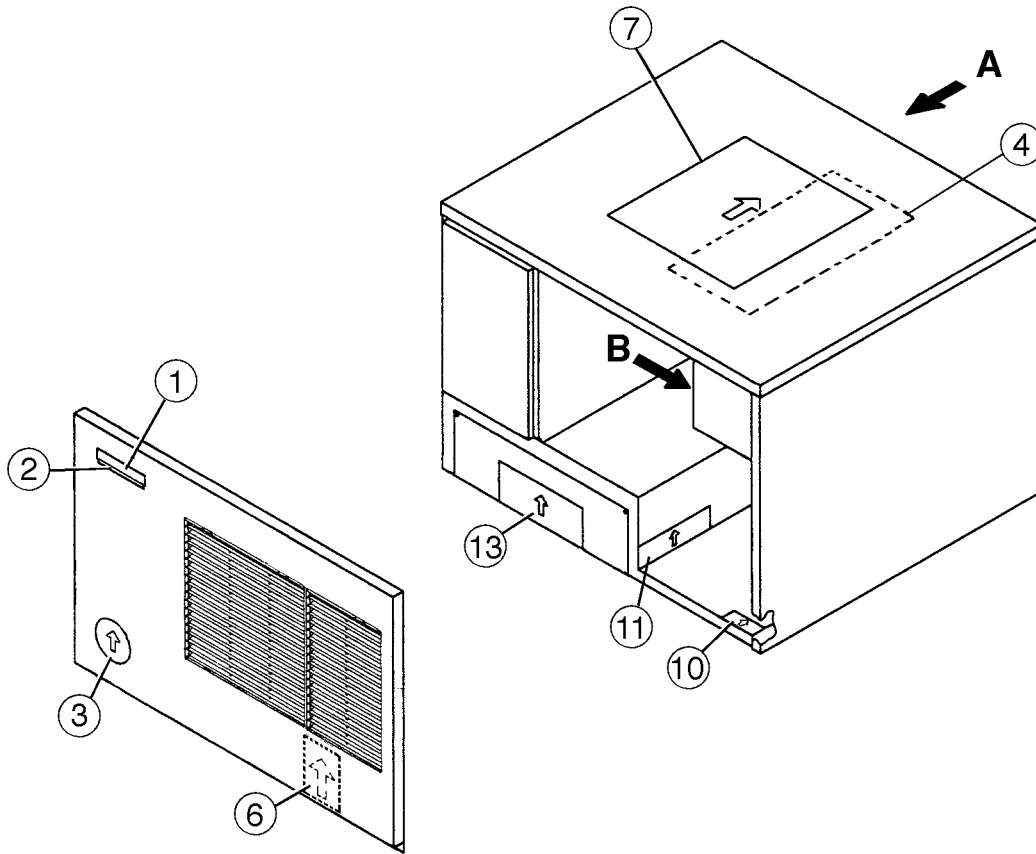

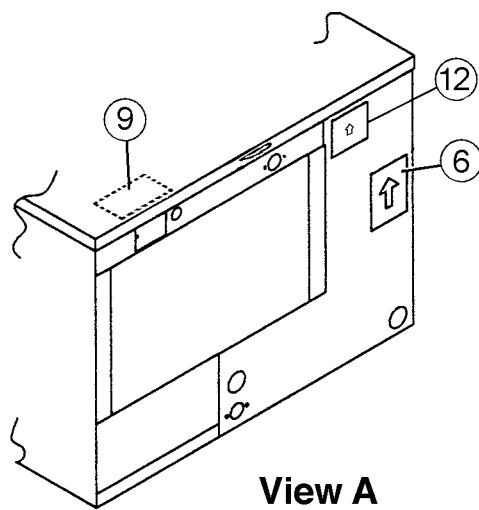
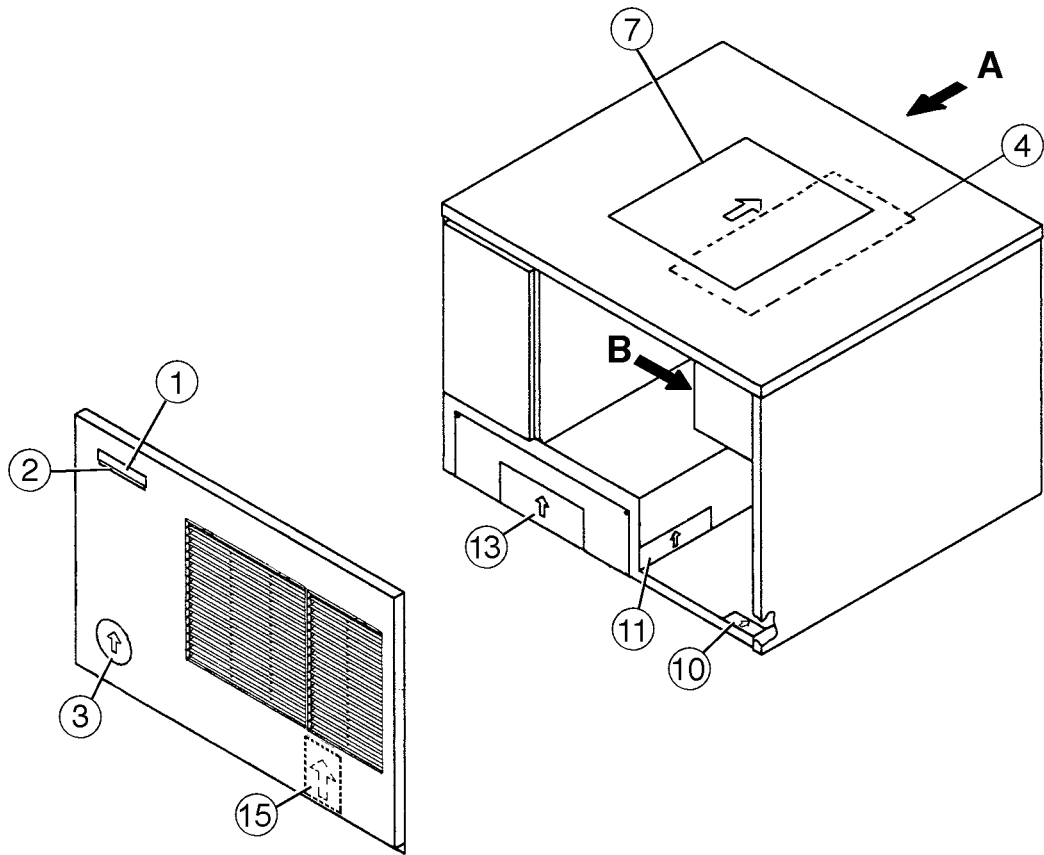

View A

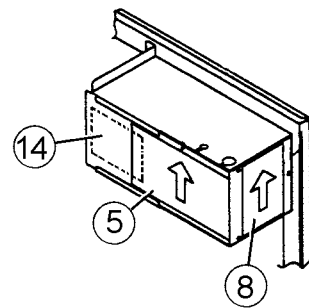

View B

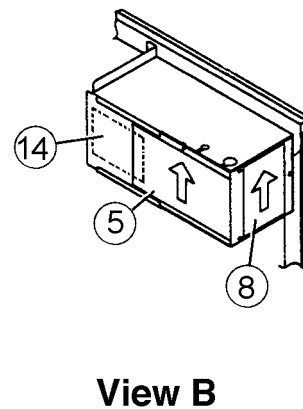
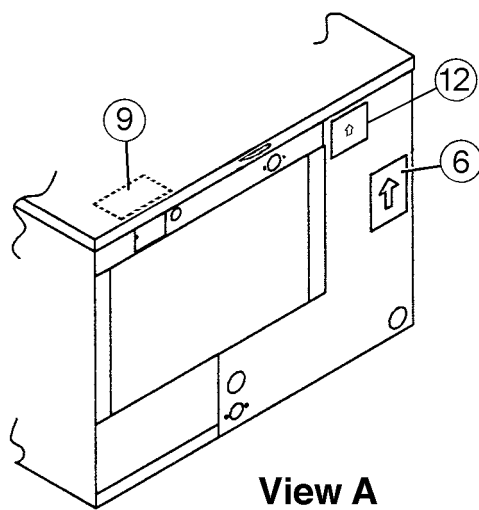
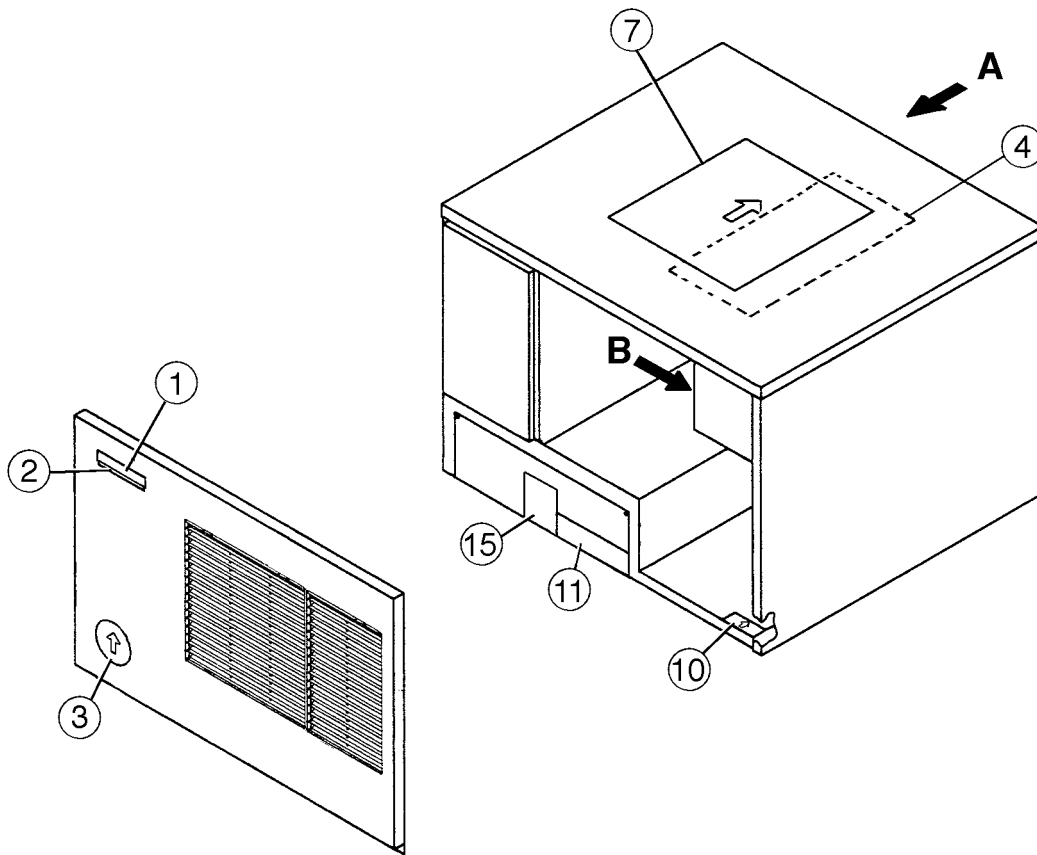



HA

MODEL: <b>KML-200MWE</b> TITLE: <b>E. LABEL LOCATION</b>								
INDEX NO.	DESCRIPTION	MATERIAL OR MODEL NUMBER	PART NUMBER	REQUIRED NUMBER				
				G-0	H-1 H-2	J00196M- J00295B	J00296D- J00425J	K-0
1	EMBLEM	PETP FILM	4A0560-01	1	1	1	1	1
2	MODEL NUMBER LABEL	PETP FILM	443341-36	1	1	1	1	1
3	LABEL - PENGUIN - HA (R)	PETP FILM	4A0526-01	1	1	1	1	1
4	MAINTENANCE LABEL	PVC FILM	3A0878-01	1	1	1	1	1
5	WIRING LABEL	PVC FILM	3A0783-01	1	1	1	1	1
6	NAMEPLATE	PES FILM	4A1197-01	2	1	2	2	1
7	INSTRUCTION SHEET	PAPER	2A0750-01	1	1	1	-	
		PAPER	2A1253-01				1	1
8	MANUAL LABEL	PVC FILM	4A1090-01	1	1	1	1	1
9	TAG - WARNING: ELECTRICAL CONNECTION	PAPER	435005-01	1	1	1	1	1
10	LABEL - R22	PES FILM	440362-01	1	1	1	1	1
11	CAUTION LABEL (K)	PVC FILM	439150-01	1	1	1	1	1
12	INSTRUCTION LABEL	PVC FILM	444575-01	1	1	1	1	1
13	WARNING LABEL - MANUAL FILL	PVC FILM	4A1091-01	1	1	1	-	
14	LABEL – CONTROL BOARD	PVC FILM	3A0998-01		1	1	1	-
		PVC FILM	3A1272-01					1
15	RATING LABEL	PES FILM	4A1610-01		1	1	1	1

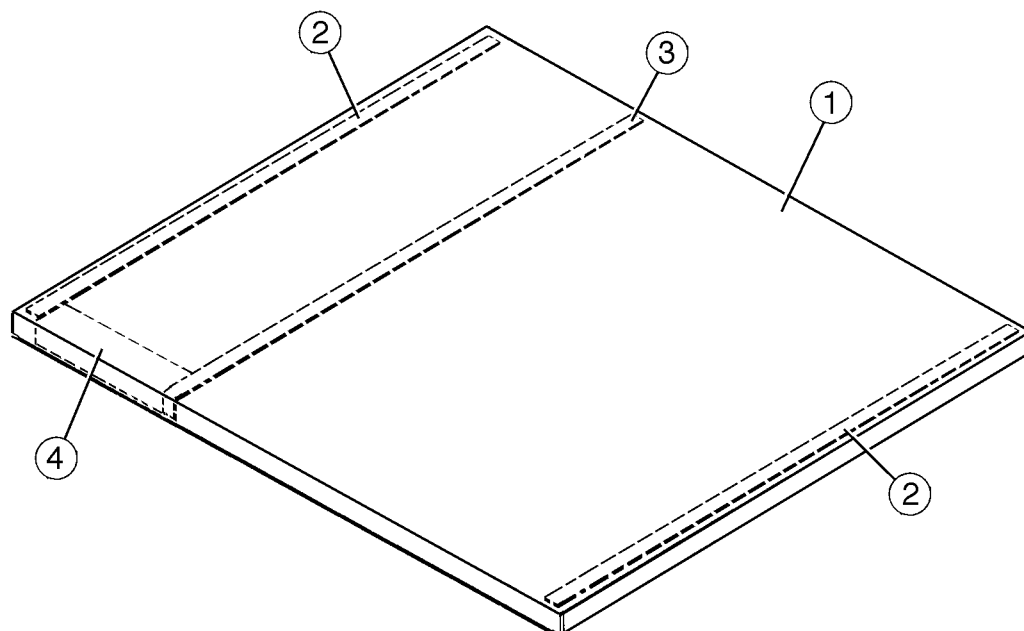

HA

MODEL: <b>KML-200MAE, MWE</b> TITLE: <b>F. TOP PANEL ASSEMBLY</b>								
INDEX NO.	DESCRIPTION	MATERIAL OR MODEL NUMBER	PART NUMBER	REQUIRED NUMBER				
				G-0	H-0	H-1 H-2	J-0	K-0
1	TOP PANEL	SS	213543-01	1	1	1	1	1
2	GASKET	PVC	<a href="#">427014-04</a>	2	2	2	2	2
3	GASKET (A)	NORMOUNT V710	<a href="#">324859-03</a>	1	1	1	1	1
4	INSULATION	PE FOAM	<a href="#">438012-01</a>	1	1	1	1	1

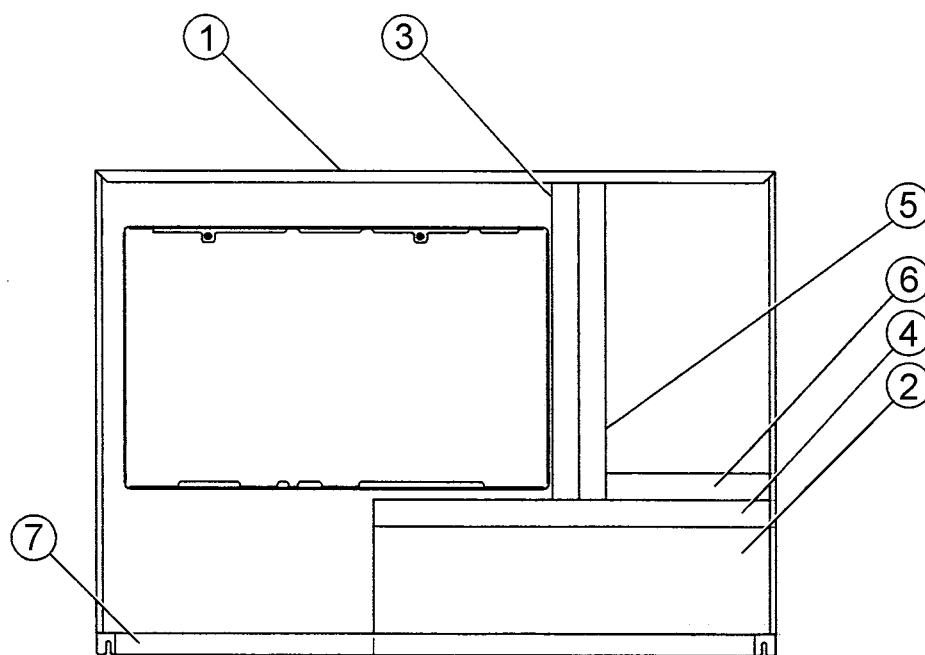

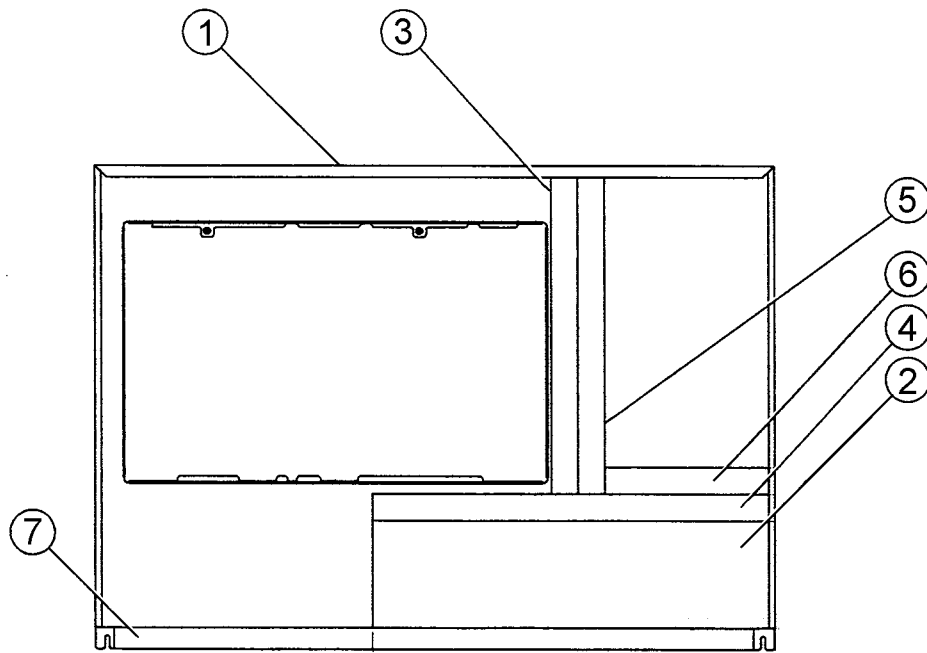

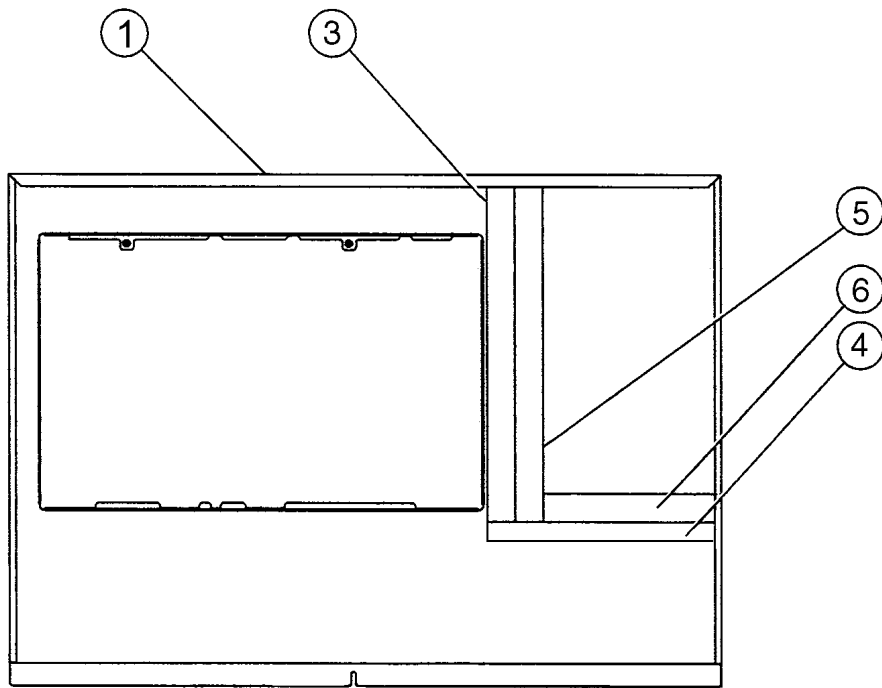

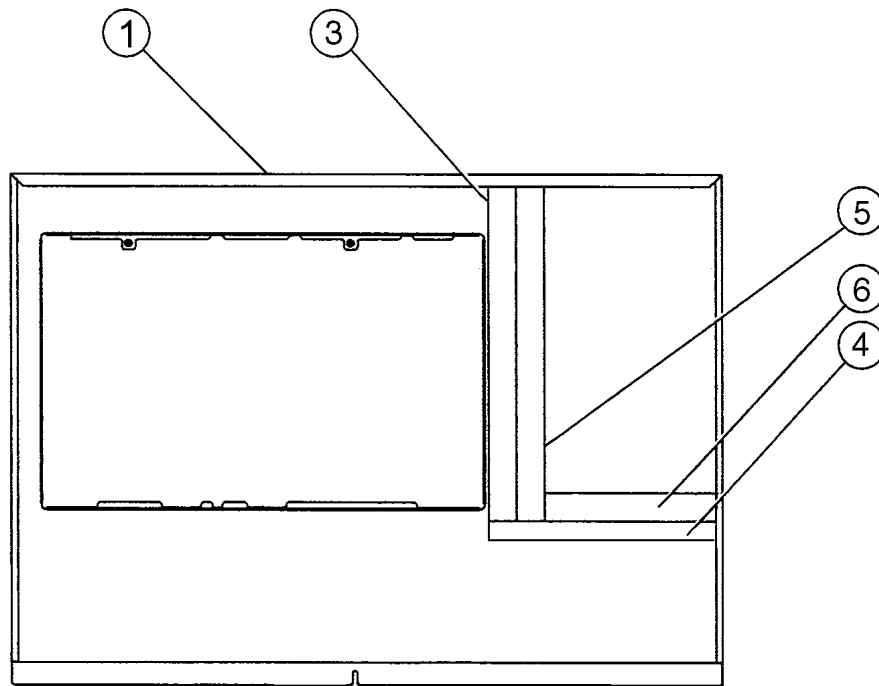

HA

MODEL: <b>KML-200MAE</b> TITLE: <b>G. FRONT PANEL ASSEMBLY</b>								
INDEX NO.	DESCRIPTION	MATERIAL OR MODEL NUMBER	PART NUMBER	REQUIRED NUMBER				
				G-0	H-0	H-1	H-2	<small>J00786C- J00636M- J00785B</small> K-0
1	FRONT PANEL (A)	SS	2A0990-01	1	1	1	1	-
		SS	2A1455-01					1
2	INSULATION - FRONT PANEL	PE FOAM	3A0673-01	1	1	1	1	-
3	FOAM SEAL	L=370	<a href="#">4A0661L01</a>	1	1	1	1	1
4	FOAM SEAL	L=450	<a href="#">4A0661L01</a>	1	1	1	1	-
		L=250	<a href="#">4A0661L01</a>					1
5	FOAM SEAL	L=370	<a href="#">4A1163L01</a>	1	1	1	1	1
6	FOAM SEAL	L=190	<a href="#">4A1163L01</a>	1	1	1	1	1
7	TAPE - NORTON SEAL	L=717	8208-0001	1	1	1	1	-



MODEL: KML-200MWE TITLE: G. FRONT PANEL ASSEMBLY								
INDEX NO.	DESCRIPTION	MATERIAL OR MODEL NUMBER	PART NUMBER	REQUIRED NUMBER				
				G-0	H-0	H-1	H-2	J00296D- J00196M- J00295B J00425J K-0
1	FRONT PANEL (A)	SS	2A0990-01	1	1	1	1	-
		SS	2A1455-01					1
2	INSULATION - FRONT PANEL	PE FOAM	3A0673-01	1	1	1	1	-
3	FOAM SEAL	L=370	4A0661L01	1	1	1	1	1
4	FOAM SEAL	L=450	4A0661L01	1	1	1	1	-
		L=250	4A0661L01					1
5	FOAM SEAL	L=370	4A1163L01	1	1	1	1	1
6	FOAM SEAL	L=190	4A1163L01	1	1	1	1	1
7	TAPE - NORTON SEAL	L=717	8208-0001	1	1	1	1	-

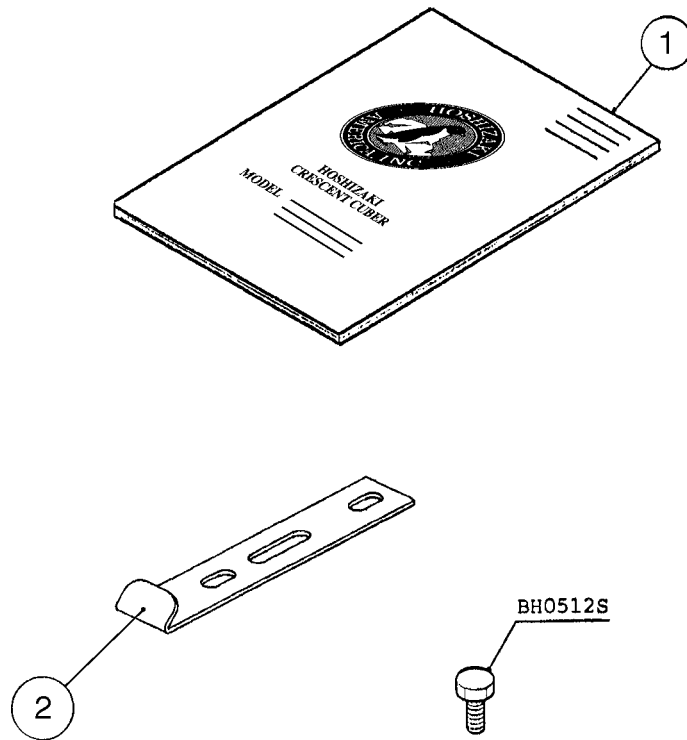

HA

MODEL: <b>KML-200MAE, MWE</b> TITLE: <b>J. ACCESSORIES</b>								
INDEX NO.	DESCRIPTION	MATERIAL OR MODEL NUMBER	PART NUMBER	REQUIRED NUMBER				
				G-0	H-0	H-1	H-2	J-0 K-0
1	INSTRUCTION MANUAL	PAPER	91A1CA10A	1	1	1	1	1
2	UNIVERSAL BRACE	GS	<a href="#">4A0363-01</a>	2	2	2	2	2