

NUMBER: 71239
ISSUED: June 8, 2005



HOSHIZAKI
TempGuard™ PASS THROUGH
MODEL
PTR1-SSB01-10

with  evercheck

The logo for "evercheck" consists of five vertical, wavy blue lines of varying heights, resembling a stylized signal or barcode, positioned to the left of the word "evercheck".

PARTS LIST

CONTENTS

Auxiliary Codes.....	3
Note About Ordering Parts	3
Material Abbreviations	4
A. Pass Through	5
B. Refrigeration System.....	7
C. Control Panel Assembly (Glass Door Side)	9
D. Front Panel Assembly - Hinged (Glass Door Side)	10
E. Control Panel Assembly (SS Door Side)	11
F. Front Panel Assembly (SS Door Side)	12
G. Body - Final.....	13
H. Label Location.....	16
J. Fan - Evaporator Assembly	17
K. Evaporator Assembly	18
L. Condenser Assembly.....	19
M. Control Box Assembly.....	20
N. Body - Prefinal.....	22
P. Door - Half (UR)	24
Q. Door - Half (LR).....	25
R. Mullion - Horizontal	26
S. Literature & Packaging	27

Auxiliary Codes

PTR1-SSB01-10	M-5 August 2002
	N-6 April 2003
	P-5 January 2004
	Q-5 December 2004

Note About Ordering Parts

Most assemblies cannot be ordered as complete units; parts in the assemblies generally must be ordered separately.

Material Abbreviations

ALUMINUM

AL = Aluminum

COPPER

CU = Copper

PLASTIC

ABS = Acrylonitrile -butadiene - styrene
AC = Polyacetal
EVA = Ethylene vinyl acetate
PA = Polyamide = Nylon
PC = Polycarbonate
PE = Polyethylene
PES = Polyester
PETP = Polyethylene terephthalate = Tetlon
PP = Polypropylene
PS = Polystyrene
PTFE = Polytetrafluoroethylene = Teflon
PUR = Polyurethane
PVC = Polyvinyl chloride

RUBBER

VN = Vinyl Nitrile
EPDM = EP rubber
NBR = Nitrile butadiene rubber
NR = Natural rubber
NP = Neoprene
SI.R = Silicone rubber
SY.R = Synthetic rubber
EPH = Epichlorohydrin

STEEL

GS = Galvanized steel
SS = Stainless steel
PS = Plated steel
PAS = Primed steel

AUXILIARY CODE

K-5

TT Designates the year. "K" indicates the year 2000. Years progress or regress in alphabetical order. "J" is 1999, "L" is 2001, "M" is 2002, and so on. The letters "I" and "O" were skipped.
T Designates significant part changes within the same year for this model. Base is 5 and this number advances for each change.

Example: P-6

TT "P" indicates 2004.
T "6" indicates the first significant part change for 2004.

A. Pass Through
PTR1-SSB01-10
M-5, N-6, P-5, Q-5

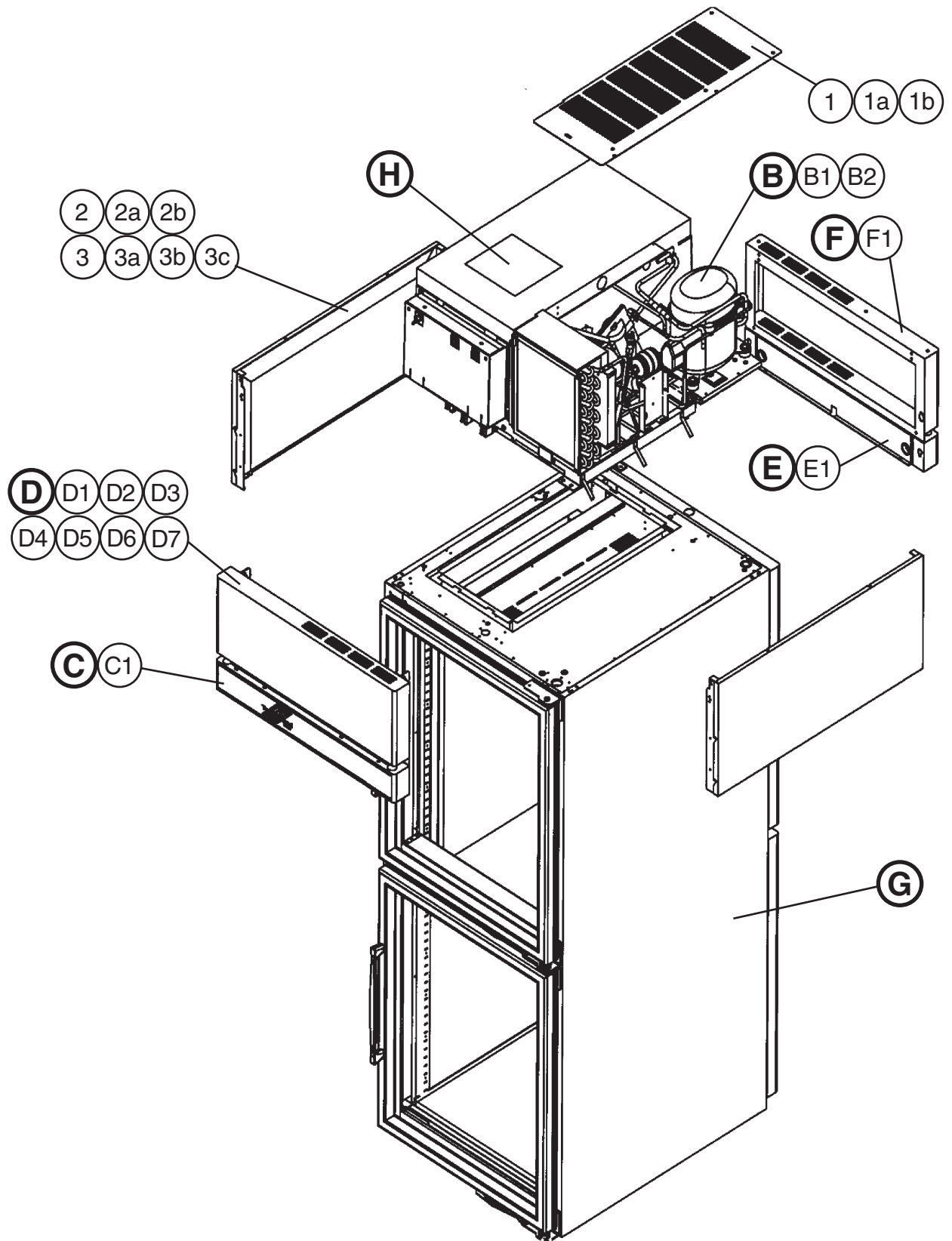

Title: **A. Pass Through** Model: **PTR1-SSB01-10**

Index No.	Description	Material or Model Number	Part Number	Required Number																
				M-5 to Q-5																
B	REFRIGERATION SYSTEM		1A0705A01	1																
B1	BOLT ASSY	8x45	437889-01	1																
B2	T2 SCREW	4x20, SS	7P32-0420	2																
C	CONTROL PANEL ASSEMBLY (GLASS DOOR SIDE)		2A1269A05	1																
C1	T2 SCREW	4x8, SS	7P32-0408	4																
D	FRONT PANEL ASSEMBLY - HINGED (GLASS DOOR SIDE)		2A2011A01	1																
D1	CLEVIS PIN		8907-0105	2																
D2	COTTER PIN		8907-0103	2																
D3	FLAT WASHER		4A0655-03	2																
D4	BRACKET-HINGE		4A2306-01	2																
D5	POP RIVET	SSD(43)SSBS	7172-4300	4																
D6	T2 SCREW	4x8, SS	7P32-0408	4																
D7	SPACER-HINGE		4A2473-01	2																
E	CONTROL PANEL ASSEMBLY (SS DOOR SIDE)		2A1269A06	1																
E1	T2 SCREW	4x8, SS	7P32-0408	4																
F	FRONT PANEL ASSEMBLY (SS DOOR SIDE)		3A2518G01	1																
F1	TRUSS HEAD SCREW	5x8, SS	7C32-0508	4																
G	BODY-FINAL		1A0687A01	1																
H	LABEL LOCATION		2A1042A11	1																
1	COVER-UL TOP		2A2505-01	1																
1a	T2 SCREW	4x8, SS	7P32-0408	2																
1b	TRUSS HEAD SCREW	5x10, SS	7C32-0510	3																
2	FRAME-SIDE TOP		2A1803-01	2																
2a	TRUSS HEAD SCREW	5x10, SS	7C32-0510	8																
2b	INSERT-THREADED	M5	4A0407-01	1																
3	PANEL-SIDE TOP		2A1800-01	2																
3a	SCREW COUNTERSUNK	5x20, SS	7C42-0520	8																
3b	TAPER COLLAR		4H0171-01	8																
3c	T2 SCREW	4x8, SS	7P32-0408	4																

B. Refrigeration System

PTR1-SSB01-10

M-5, N-6, P-5, Q-5

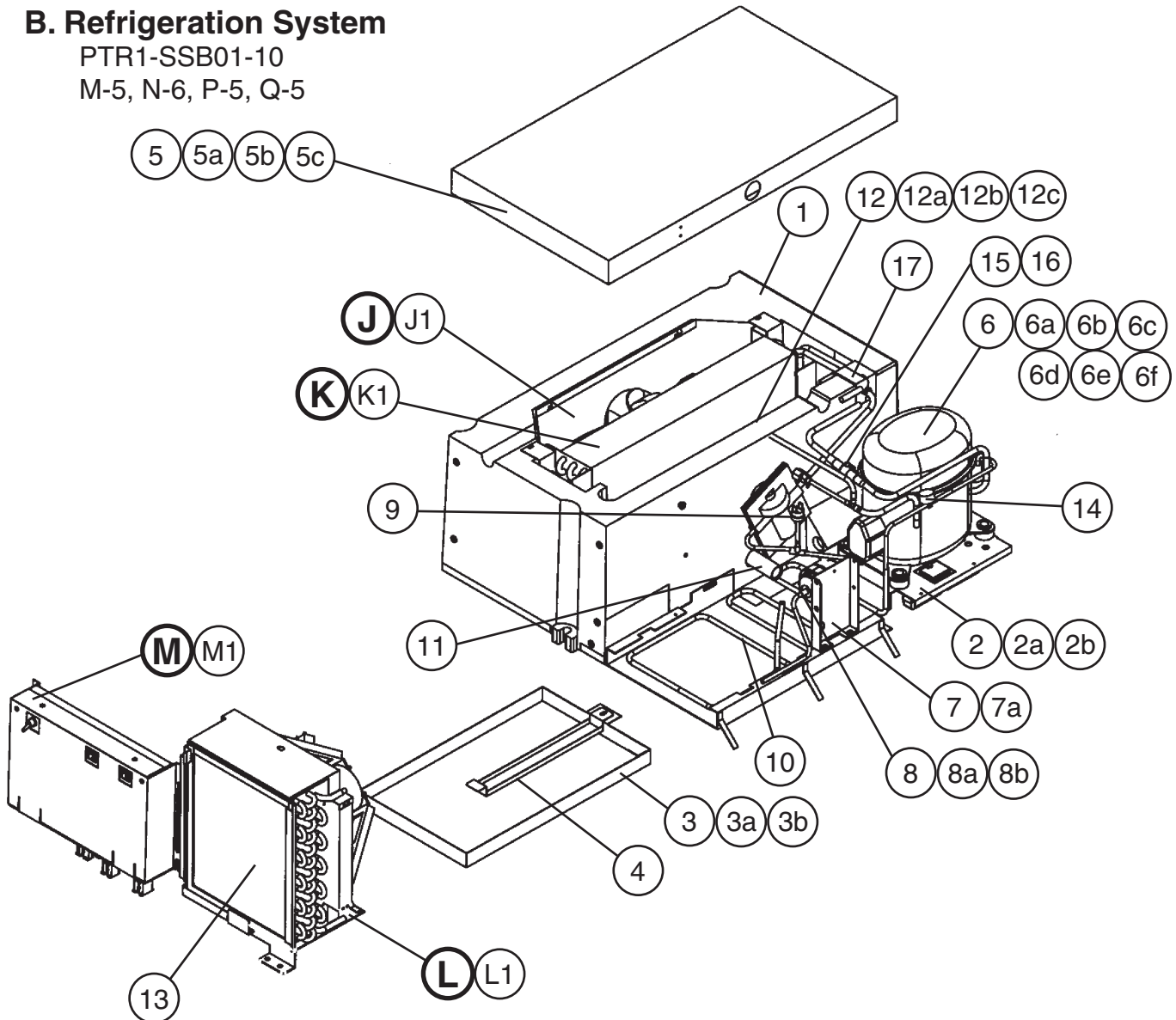

Title: **B. Refrigeration System** Model: **PTR1-SSB01-10**

Index No.	Description	Material or Model Number	Part Number	Required Number																
				M-5 to Q-5																
J	FAN-EVAPORATOR ASSY		2A0980A01	1																
J1	TRUSS HEAD SCREW	4x12, SS	7C32-0412	4																
K	EVAPORATOR ASSEMBLY		2A0981A04	1																
K1	TRUSS HEAD SCREW	4x20, SS	7C32-0420	2																
L	CONDENSER ASSEMBLY		3A2611A01	1																
L1	T2 SCREW	4x8, SS	7P32-0408	2																
M	CONTROL BOX ASSEMBLY		2A1729A02	1																
M1	TRUSS HEAD SCREW	4x16, SS	7C32-0416	4																

Title: **B. Refrigeration System** Model: **PTR1-SSB01-10**

Index No.	Description	Material or Model Number	Part Number	Required Number									
				M-5 to Q-5									
1	EVAP-CASE POSTFOAM		1A0712G05	1									
2	BASE-COMPRESSOR		2A2756G01	1									
2a	TRUSS HEAD SCREW	4x16, SS	7C32-0416	1									
2b	TRUSS HEAD SCREW	5x10, SS	7C32-0510	1									
3	PAN-EVAP DRAIN		2A0616-03	1									
3a	TRUSSHEAD SCREW	5X12, SS	7C32-0512	1									
3b	GASKET-COND COIL		4A0455-03	1									
4	STRAP-CONDENSATE COIL		3A0232-03	1									
5	COVER-EVAP CASE(1 SEC)		2A2726G01	1									
5a	DRAW LATCH		4A1710-01	4									
5b	TRUSS HEAD SCREW	4x16, SS	7C32-0416	4									
5c	T2 SCREW	4x8, SS	7P32-0408	8									
6	COMPRESSOR		4A2785-01	1									
6a	GROMMET		4A2593-01	4									
6b	SPACER		4A2595-01	4									
6c	HEX BOLT	8x45	7B01-0845	4									
6d	FLAT WASHER	8	7W21-0800	4									
6e	SPLIT LOCK WASHER	8	7L21-0800	4									
6f	PROTECTOR		4A2634-02	1									
7	DRIER BRACKET		4A0806-01	1									
7a	T2 SCREW	4X8, SS	7P32-0408	2									
8	DRIER		4A0924-01	1									
8a	MOUNT-DRIER		4A1480-01	1									
8b	T2 SCREW	4X8, SS	7P32-0408	2									
9	SWITCH-PRESSURE		4A2516-02	1									
10	COIL-CONDENSATE		3A1644-01	1									
11	PIPE-EVAP DRAIN		4A0831-01	1									
12	THERMISTOR-CABINET	TAIKO 4A1429	4A1429-01	1									
12a	THERMISTOR BRACKET		433964-01	1									
12b	THERMISTOR BRACKET		433920-01	1									
12c	TRUSS HEAD SCREW	4x16, SS	7C32-0416	2									
13	FILTER-COND		3A0277-01	1									
14	THERMOSTAT-CLEAN FILTER		4A0484-02	1									
15	HOLDER/EXP. VALVE		3A0107-01	1									
16	HOSE CLAMP		443461-01	1									
17	SEAL-EVAP TUBING		4A0642-01	2									

C. Control Panel Assembly (Glass Door Side)

PTR1-SSB01-10
M-5, N-6, P-5, Q-5

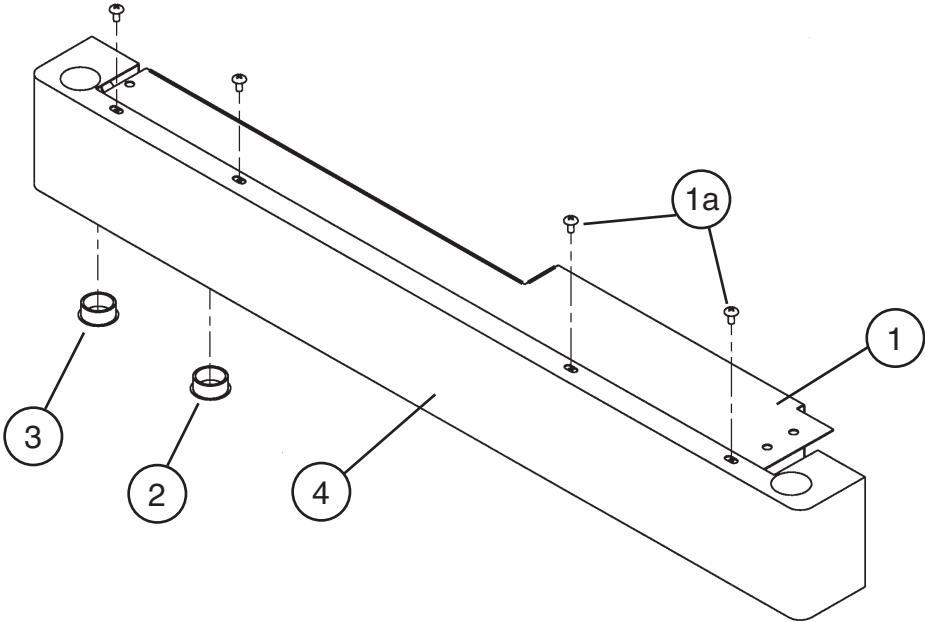

Title: C. Control Panel Assembly (Glass Door Side) Model: PTR1-SSB01-10					Required Number								
Index No.	Description	Material or Model Number	Part Number	M-5 to Q-5									
					1	COVER-WIRE		2A1033-01	1				
1a	T2 SCREW	4X8 SUS	7P32-0408	4									
2	LOCKING HOLE PLUG		4A0586-02	2									
3	LOCKING HOLE PLUG		4A0586-03	1									
4	PANEL-CONTROL		1A0760-03	1									

D. Front Panel Assembly - Hinged (Glass Door Side)

PTR1-SSB01-10

M-5, N-6, P-5, Q-5

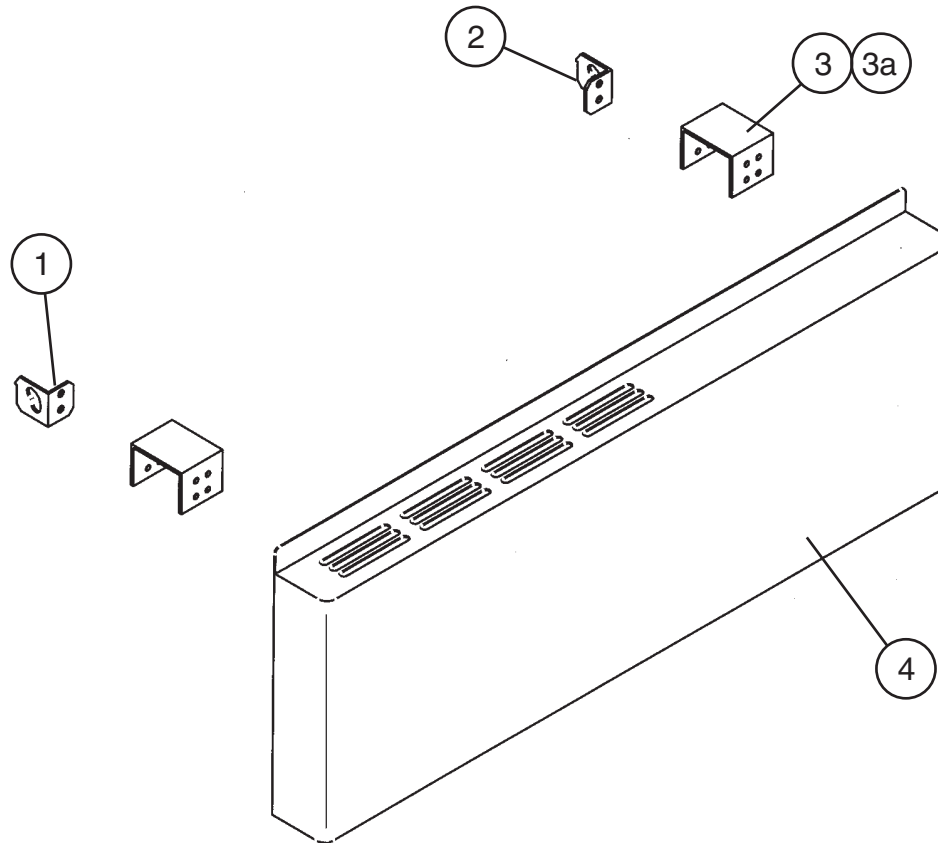

Title: D. Front Panel Assembly - Hinged (Glass Door Side) Model: PTR1-SSB01-10										
Index No.	Description	Material or Model Number	Part Number	Required Number						
				M-5 to Q-5						
1	HINGE – FRONT PANEL (L)	GS	4A2153-01	1						
2	HINGE – FRONT PANEL (R)	GS	4A2154-01	1						
3	CHANNEL – HINGE	GS	4A2170-01	2						
3a	TRUSS HEAD SCREW	5X8, SS	7C32-0508	4						
4	PANEL – FRONT	SS	1A0624-01	1						

E. Control Panel Assembly (SS Door Side)

PTR1-SSB01-10

M-5, N-6, P-5, Q-5

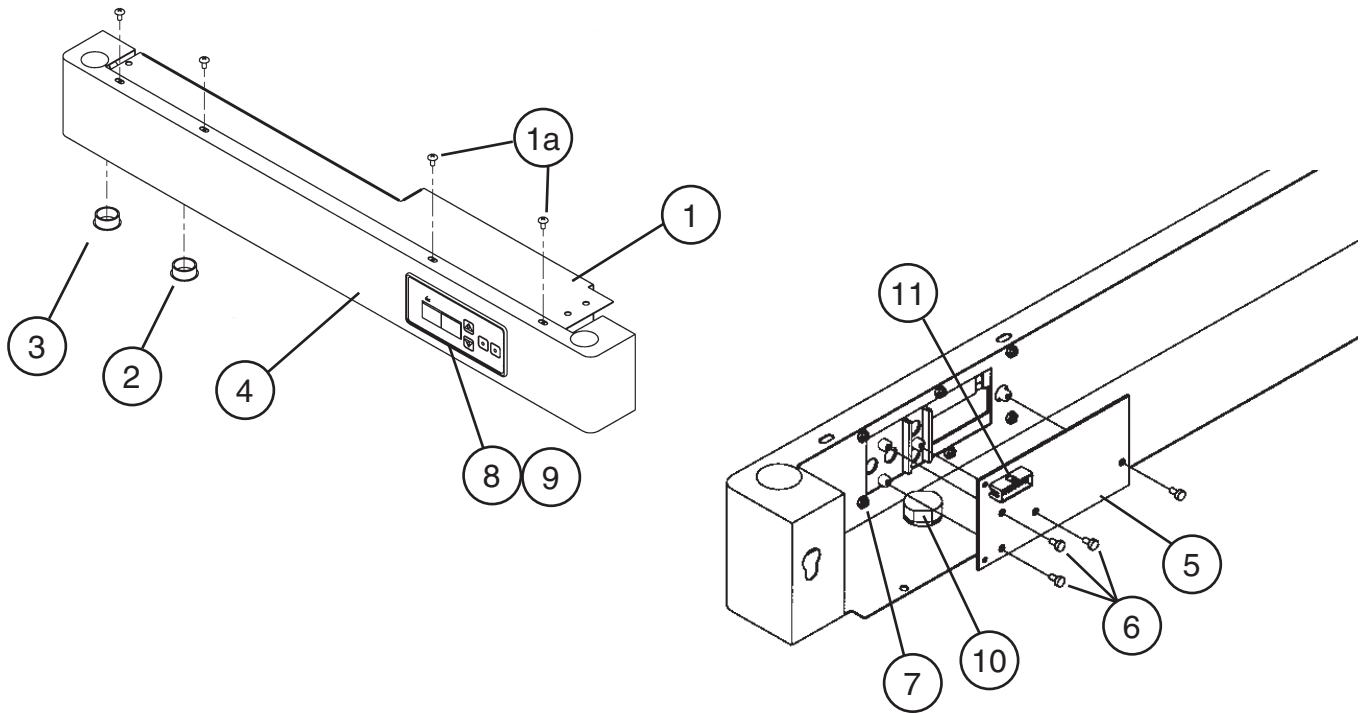

Title: E. Control Panel Assembly (SS Door Side) Model: PTR1-SSB01-10					Required Number							
Index No.	Description	Material or Model Number	Part Number	M-5 to Q-5								
					1	COVER-WIRE		3A2577-01	1			
1a	T2 SCREW	4X8 SUS	7P32-0408	4								
2	LOCKING HOLE PLUG		4A0586-02	2								
3	LOCKING HOLE PLUG		4A0586-03	1								
4	PANEL-CONTROL		1A0760-01	1								
5	BOARD-DISPLAY		2A0883-01	1								
6	NYLON SCREW		4A1397-01	4								
7	PALNUT		4A1398-01	6								
8	MOUNT-DISPLAY BOARD		3A0823-01	1								
9	LABEL-DISPLAY		3A2850-01	1								
10	BUSHING	SB-1093-15	420470-03	2								
11	RIBBON CABLE		4A1106-03	1								

F. Front Panel Assembly (SS Door Side)

PTR1-SSB01-10

M-5, N-6, P-5, Q-5

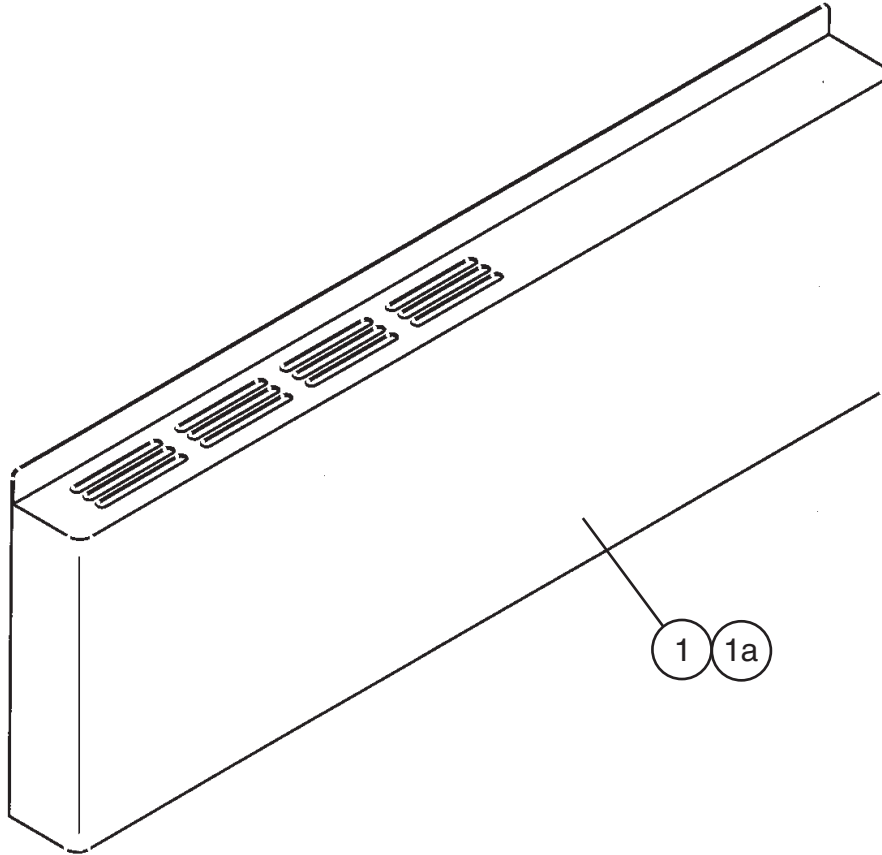

Title: F. Front Panel Assembly (SS Door Side) Model: PTR1-SSB01-10										
Index No.	Description	Material or Model Number	Part Number	Required Number						
				M-5 to Q-5						
1	PANEL – FRONT	SS	1A0624-05	1						
1a	THREADED INSERT	M5	4A0407-01	2						

G. Body - Final

(1/2)

PTR1-SSB01-10

M-5, N-6, P-5, Q-5

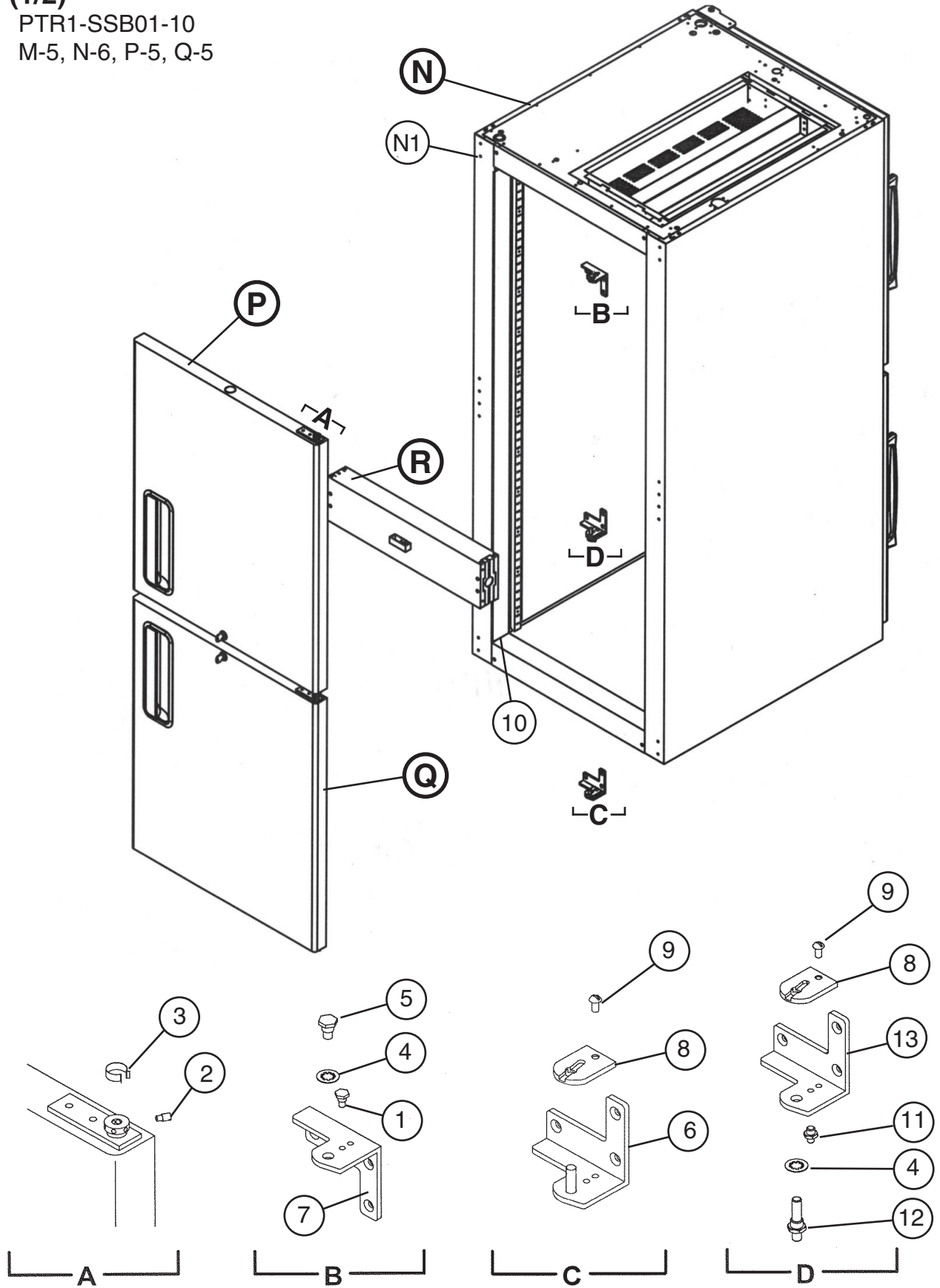

G. Body - Final

(2/2)

PTR1-SSB01-10

M-5, N-6, P-5, Q-5

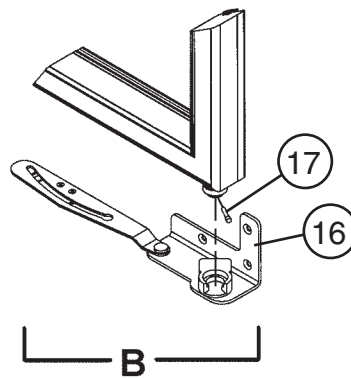
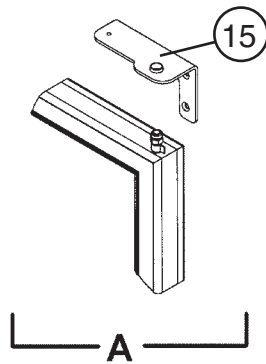
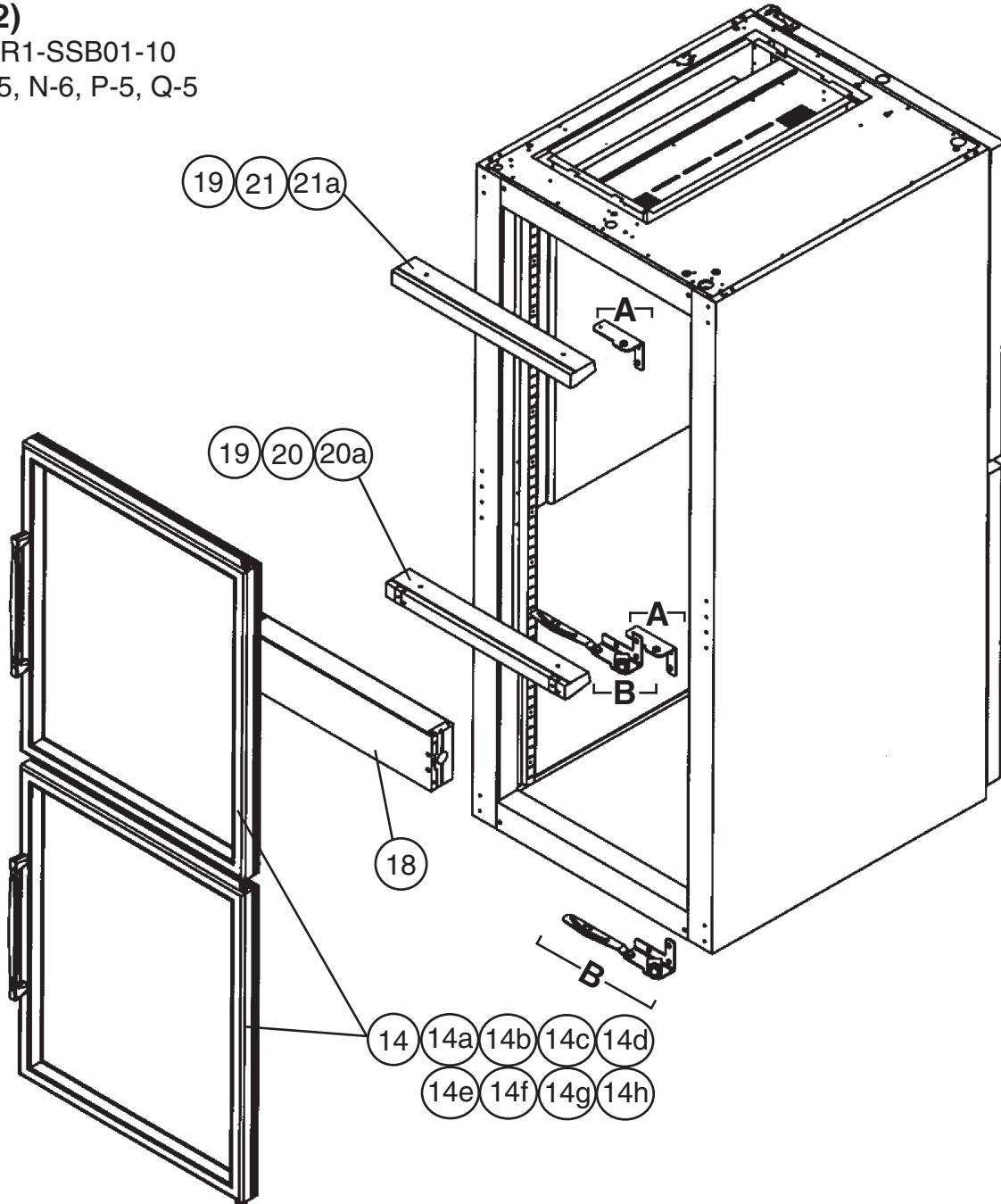

Title: **G. Body - Final** Model: **PTR1-SSB01-10**

Index No.	Description	Material or Model Number	Part Number	Required Number									
				M-5 to Q-5									
N	BODY-PREFINAL		1A0354A05	1									
N1	TRUSSHEAD SCREW	5X10 SUS	7C32-0510	25									
P	DOOR-HALF(UR)		1A0326A03	1									
Q	DOOR-HALF(LR)		1A0324A03	1									
R	MULLION-HORIZONTAL		2A1323A05	1									
1	HINGE-STOP PIN		4A2180-01	1									
2	HINGE-TENSION SCREW		4A0446-01	2									
3	HINGE-BUSHING COVER		4A0445-01	2									
4	HINGE-LOCK WASHER		4A0553-01	2									
5	HINGE-PIVOT PIN(TOP)		4A2179-01	1									
6	BRACKET-DOOR HINGE(LR)		3A1626-01	1									
7	BRACKET-DOOR HINGE(UR)		3A1580-01	1									
8	HINGE-STOP PLATE(R)		4A0441-01	2									
9	SCREW-STOP PLATE		4A0483-01	2									
10	COVER-CORNER		3A1751-01	8									
11	STOP PIN		4A1734-01	1									
12	PIVOT PIN		4A1735-01	1									
13	BRACKET-DOOR HINGE(UL)		3A1581-01	1									
14	GLASSDOOR-HALF(R)		4A2819-01	2									
14a	PIN-GLASSDOOR		4A2047-01	2									
14b	CLIP-GLASSDOOR		4A2048-02	2									
14c	ROD-TORQUE		4A2072-02	2									
14d	GASKET-GLASSDOOR		4A2052-02	2									
14e	HANDLE-GLASSDOOR		4A2106-01	2									
14f	CRANK, TORQUE		4A2068-01	4									
14g	PIN, TORQUE		4A2071-01	2									
14h	PLUG-HALF GLASSDOOR		4A2818-01	2									
15	HALF GLASSDOOR HINGE-UPPER		3A2442G01	2									
16	HALF GLASSDOOR HINGE-LOWER		3A2443G01	2									
17	PIN, TORQUE		4A2071-01	2									
18	MULLION-PREFOAM(H)		2A1313G05	1									
19	LAMP-FLUORESCENT		4A2787-01	2									
20	LAMPHOLDER-LOWER		3A2498G02	1									
20a	T2 SCREW	4x8 SUS	7P32-0408	2									
21	LAMPHOLDER-UPPER		3A2498G01	1									
21a	TRUSSHEAD SCREW	5X10 SUS	7C32-0510	2									

H. Label Location

PTR1-SSB01-10

M-5, N-6, P-5, Q-5

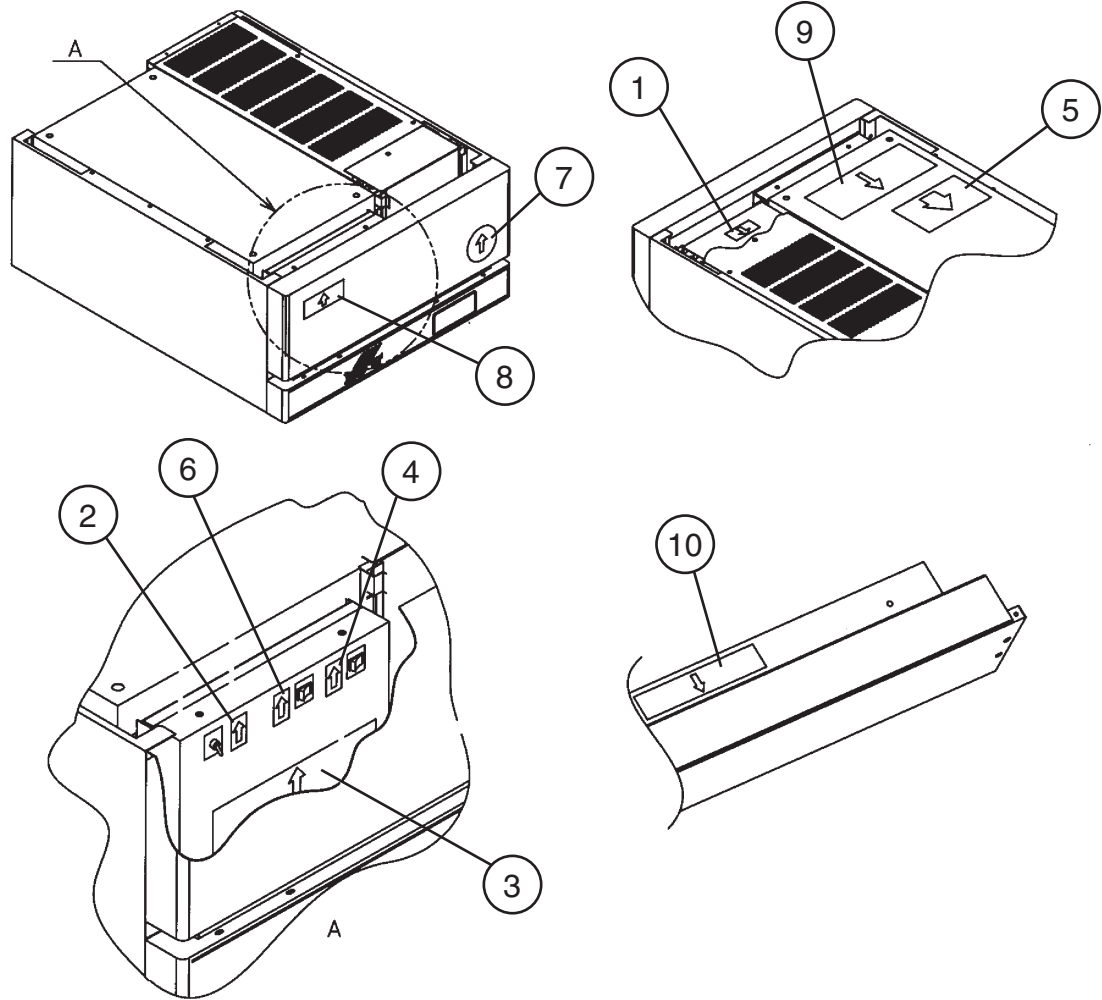

Title: H. Label Location Model: PTR1-SSB01-10										
Index No.	Description	Material or Model Number	Part Number	Required Number						
				M-5 to Q-5						
1	LABEL-R404A		4A0960-01	1						
2	LABEL-ON/OFF		4A0522-01	1						
3	LABEL-DISPLAY INFO		3A1413-01	1						
4	LABEL-DOOR HEATER SWITCH		4A1039-01	1						
5	CAUTION LABEL		4A1931-01	1						
6	LABEL-GLASSDOOR HEATER SWITCH		4A2076-01	1						
7	LABEL-PENGUIN-HA(L)		4A0526-02	2						
8	EMBLEM-HOSHIZAKI		4A0560-01	2						
9	WIRING LABEL		2A2602-01	1						
10	LABEL-WARNING		4A2968-02	1						

J. Fan - Evaporator Assembly

PTR1-SSB01-10

M-5, N-6, P-5, Q-5

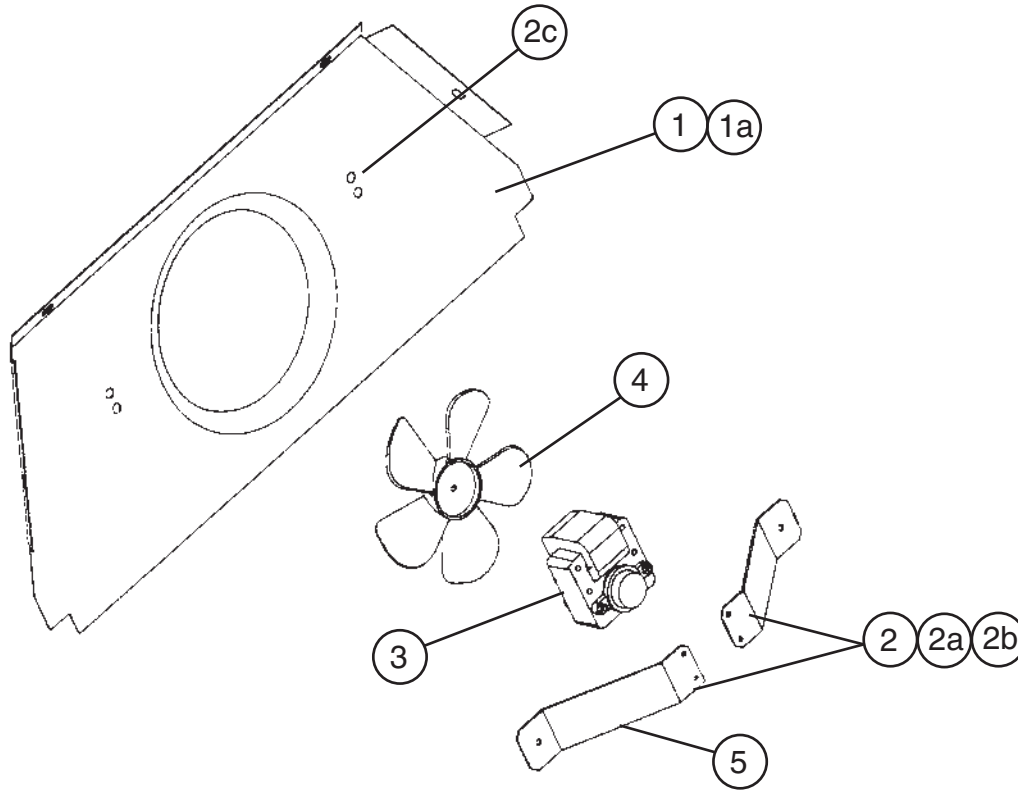

Title: J. Fan - Evaporator Assembly Model: PTR1-SSB01-10					Required Number								
Index No.	Description	Material or Model Number	Part Number	M-5 to Q-5									
1	SHROUD-EVAPORATOR		2A0846-01	1									
1a	TRUSS HEAD SCREW	4x16, SS	7C32-0416	4									
2	BRACKET-FAN MOTOR		3A2501-01	2									
2a	TRUSS HEAD SCREW	5x12, SS	7C32-0512	2									
2b	LOCK WASHER		4A0459-01	2									
2c	THREADED INSERT	M5	4A0407-01	2									
3	FAN MOTOR-EVAPORATOR		4A2563-01	1									
3a	TRUSS HEAD SCREW	4x40, SS	7C32-0440	4									
3b	SPLIT LOCK WASHER	4, SS	7L22-0400	4									
3c	HEX NUT	4, SS	7N12-0400	4									
4	BLADE-EVAPORATOR FAN		4A2378-01	1									
5	WIRE TIE (TWIST)		4A1223-01	1									

K. Evaporator Assembly

PTR1-SSB01-10

M-5, N-6, P-5, Q-5

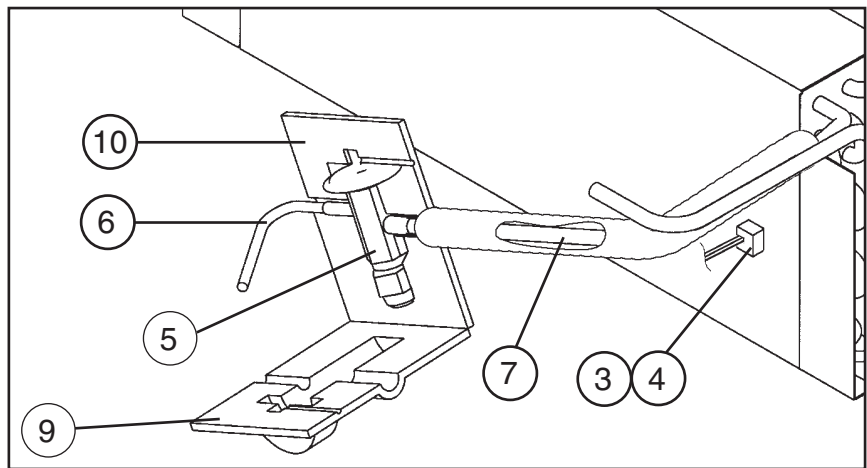
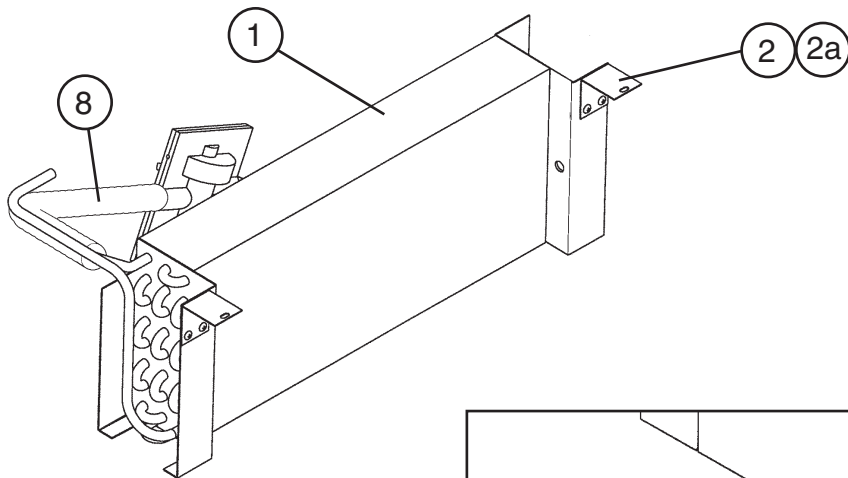

Title: K. Evaporator Assembly Model: PTR1-SSB01-10					Required Number								
Index No.	Description	Material or Model Number	Part Number	M-5 to Q-5									
1	EVAPORATOR	999349	2A0781-01	1									
2	BRACKET-EVAPORATOR	SS	4A1588-01	2									
2a	T2 SCREW	4X8, SS	7P32-0408	4									
3	THERMISTOR CLIP	-	320418-01	1									
4	THERMISTOR-DEFROST	-	4A1428-01	1									
5	VALVE-EXPANSION	Y1150-EFS-1/8-C	4A1594-01	1									
6	TUBE-LIQUID	CU	4A2210-01	1									
7	TUBE-EVAP-INLET	CU	4A1292-02	1									
8	INSULATION TUBING	L=450	7762-0717	1									
9	EXP. VALVE COVER (A)	PE FOAM	3A0372-01	1									
10	EXP. VALVE COVER (B)	PE FOAM	3A0372-02	1									

L. Condenser Assembly

PTR1-SSB01-10
M-5, N-6, P-5, Q-5

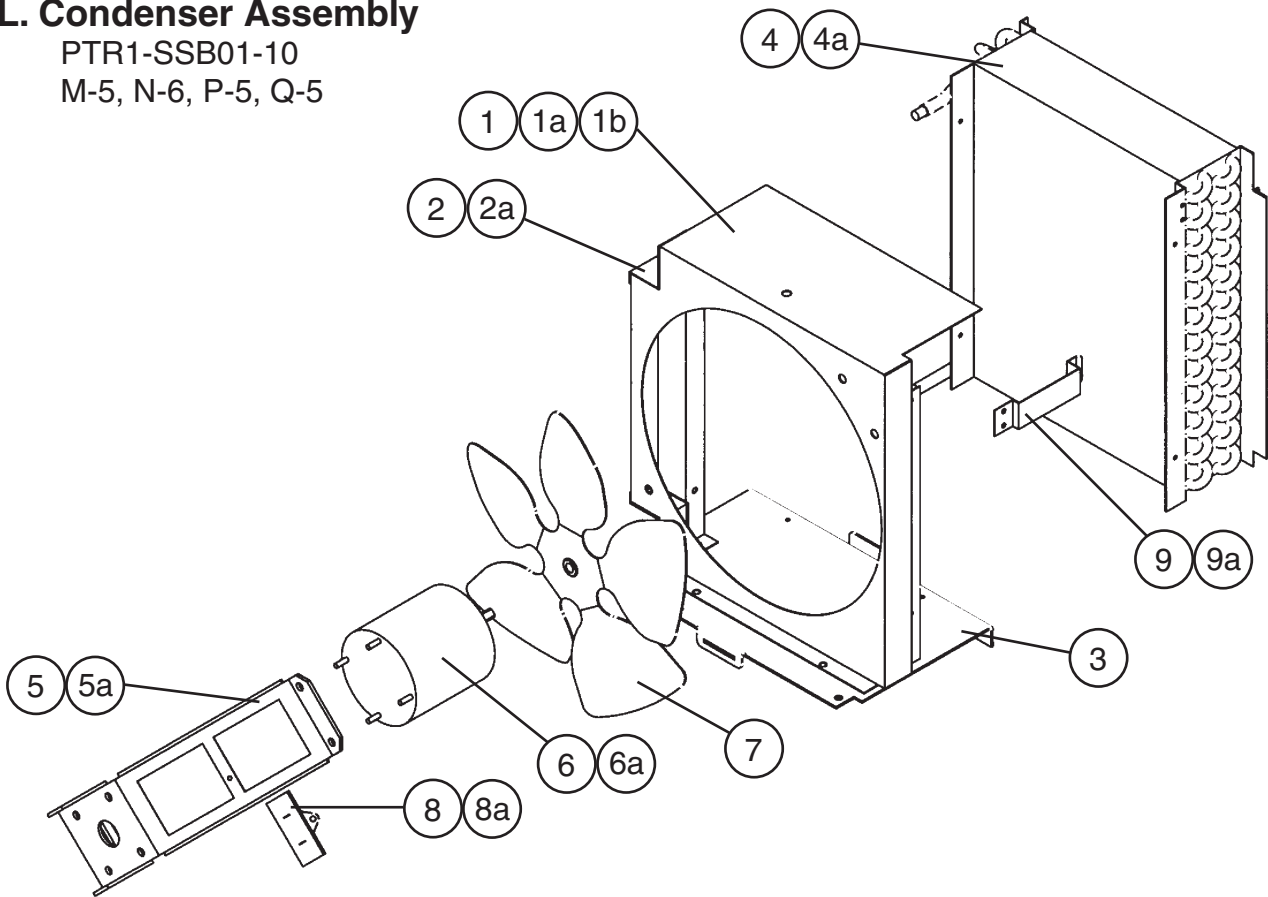

Title: L. Condenser Assembly Model: PTR1-SSB01-10											
Index No.	Description	Material or Model Number	Part Number	Required Number							
				M-5 to Q-5							
1	SHROUD-CONDENSER		2A2723-01	1							
1a	T2 SCREW	4x8 SUS	7P32-0408	4							
1b	INSERT-THREADED	(M5)	4A0407-01	5							
2	CLIP-COND SHROUD		4A2987-01	2							
2a	POP RIVET	SSD(43)SSBS	7172-4300	4							
3	BASE-CONDENSER		2A2724G01	1							
4	CONDENSER		2A0782-01	1							
4a	T2 SCREW	4x8 SUS	7P32-0408	4							
5	BRACKET-MOTOR		3A2352-01	1							
5a	TRUSS HEAD SCREW	5x10 SUS	7C32-0510	4							
6	FAN MOTOR		4A3158-01	1							
6a	SELF LOCKING NUT	#8X32	7N2110832	4							
7	FAN BLADE(PULLER)		4A1865-01	1							
8	CAPACITOR		443192-02	1							
8a	T2 SCREW	4x8 SUS	7P32-0408	1							
9	RETAINER-FILTER		4A0790-01	1							
9a	T2 SCREW	4x8 SUS	7P32-0408	2							

M. Control Box Assembly

PTR1-SSB01-10

M-5, N-6, P-5, Q-5

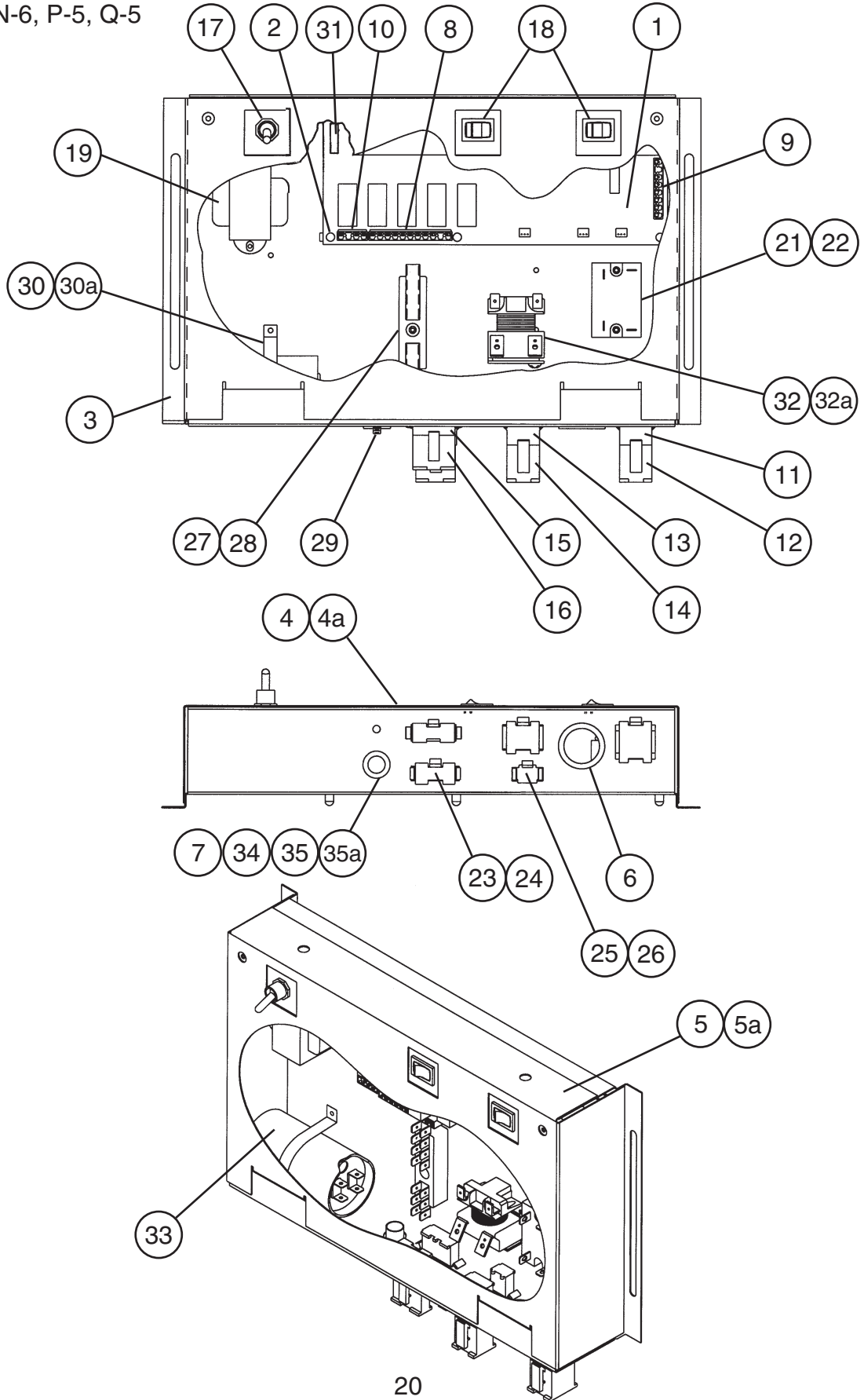

Title: **M. Control Box Assembly** Model: **PTR1-SSB01-10**

Index No.	Description	Material or Model Number	Part Number	Required Number									
				M-5 to Q-5									
1	BOARD-CONTROL		2A2862-21	1									
2	BOARD SUPPORT		4A0336-03	6									
3	BASE-CONTROL BOX		2A1146-01	1									
4	COVER-CONTROL BOX		2A1031-02	1									
4a	T2 SCREW	4x8 SUS	7P32-0408	2									
5	SWITCH-BRACKET		2A1032-02	1									
5a	T2 SCREW	4x8 SUS	7P32-0408	2									
6	BUSHING	SB-1093-15	420470-03	1									
7	BUSHING	SB-625-8	420470-01	1									
8	BOARD CONNECTOR	5198-10	434003-05	1									
9	BOARD CONNECTOR	5198-07	434003-07	1									
10	BOARD CONNECTOR	5198-03	434003-11	1									
11	PLUG HOUSING(9 PIN)	3191-09P	412832-02	1									
12	RECEPTACLE HOUSING(9 PIN)	3191-09R1	412831-02	1									
13	PLUG HOUSING(6 PIN)	3191-06P	412832-03	1									
14	RECEPTACLE HOUSING(6 PIN)	3191-06R1	412831-03	1									
15	PLUG HOUSING	03-12-1036	4A0425-01	1									
16	RECEPTACLE HOUSING	03-12-1035	4A0426-01	1									
17	SWITCH-TOGGLE	780K21	4A0424-01	1									
18	SWITCH-ROCKER	1801.110	4A0418-01	2									
19	TRANSFORMER		3A1759-01	1									
20	TAPPING SCREW	3x8	431415-01	2									
21	COMP RELAY		4A1307-01	1									
22	TAPPING SCREW	3x8	431415-01	2									
23	RECEPTACLE HOUSING(4 PIN)	3191-04R1	412831-05	1									
24	PLUG HOUSING(4 PIN)	3191-4P	412832-05	1									
25	RECEPTACLE HOUSING(2 PIN)	3191-02R1	412831-07	1									
26	PLUG HOUSING(2 PIN)	3191-2P	412832-07	1									
27	TERMINAL BLOCK		4A2619-01	1									
28	TAPPING SCREW	3x8	431415-01	2									
29	GROUNDING SCREW(M5)		433304-02	1									
30	STRAP		4A2262-02	1									
30a	T2 SCREW	4x8 SUS	7P32-0408	1									
31	BOARD CONNECTOR	5198-03	434003-09	1									
32	RELAY-START		4A2370-02	1									
32a	T2 SCREW	4x8 SUS	7P32-0408	1									
33	CAPACITOR-START		4A2668-02	1									
34	POWER CORD		4A0520-01	1									
35	WIRE CLAMP		4A0809-02	1									
35a	T2 SCREW	4x8, SS	7P32-0408	1									

N. Body - Prefinal

PTR1-SSB01-10

M-5, N-6, P-5, Q-5

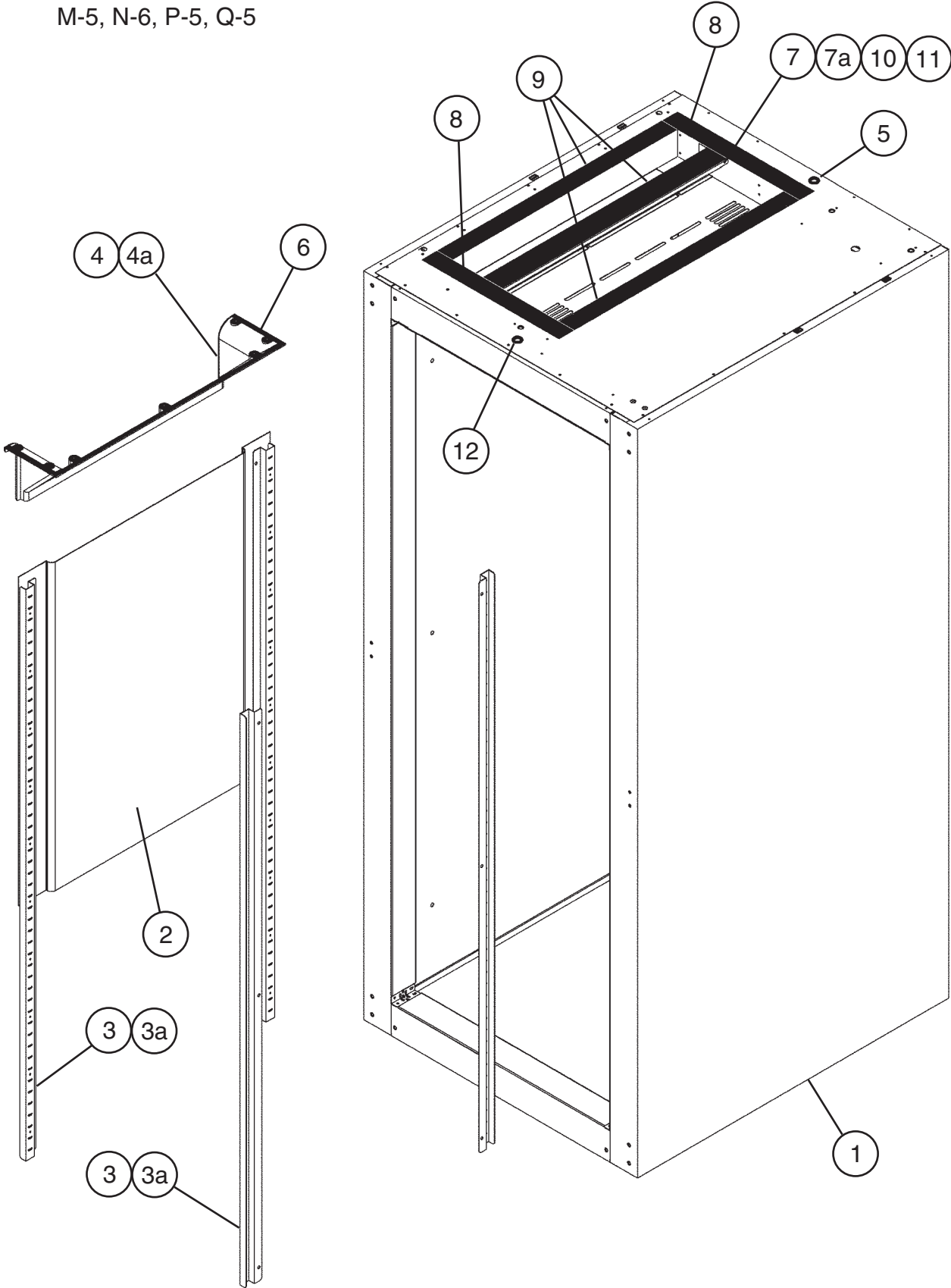

Title: **N. Body - Prefinal** Model: **PTR1-SSB01-10**

Index No.	Description	Material or Model Number	Part Number	Required Number									
				M-5 to Q-5									
1	CABINET PREFOAM	-	1A0353G05	1									
2	DISTRIBUTOR-AIR (BOTTOM)	SS	2A0425-01	1									
3	PILASTER	SS	3A2353-01	4									
3a	TRUSS HEAD SCREW	5X10, SS	7C32-0510	12									
4	DISTRIBUTOR-AIR TOP ASSEMBLY	-	2A0438G01	1									
4a	T2 SCREW	4X8, SS	7P32-0408	7									
5	BUSHING	OCB-500	428394-02	1									
6	GASKET-PVC	PVC FOAM	4A0808L02	1									
7	DIVIDER-AIR	SS	2A0199-01	1									
7a	T2 SCREW	4X8, SS	7P32-0408	4									
8	GASKET-PVC	PVC FOAM	4A0414L01	2									
9	GASKET-PVC	PVC FOAM	4A0414L01	3									
10	PLATE-ABS	ABS	4A0758-01	4									
11	TWO SIDED TAPE	3M VHB 4930	4A0415L01	2									
12	BUSHING	OCB-875	428394-04	1									

P. Door - Half (UR)

PTR1-SSB01-10

M-5, N-6, P-5, Q-5

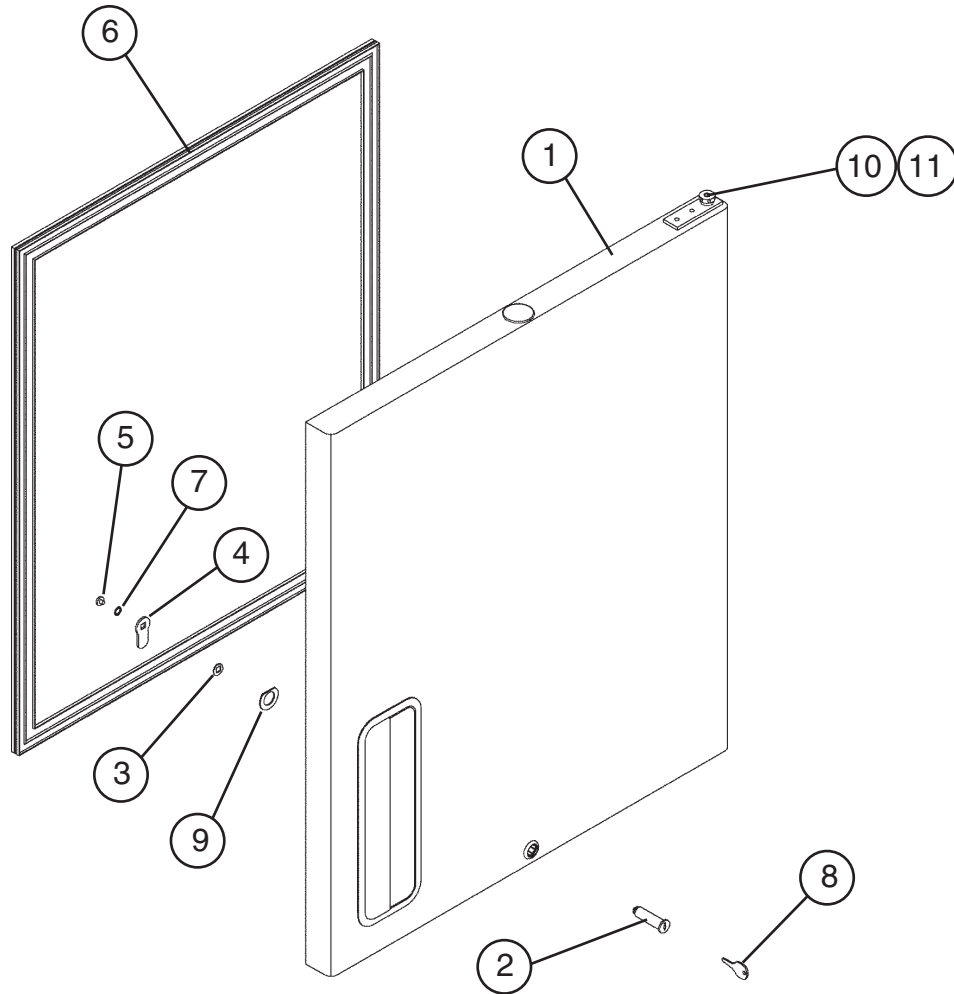

Title: **P. Door - Half (UR)** Model: **PTR1-SSB01-10**

Index No.	Description	Material or Model Number	Part Number	Required Number												
				M-5 to Q-5												
1	DOOR-PREFOAM (UR)	-	1A0325G03	1												
2	LOCK-TUMBLER	M4-5813-001	4A0462-01	1												
3	LOCK-STOP WASHER	M5-8060-103	4A0458-01	1												
4	CAM-DOOR LOCK	P.S	4A0228-01	1												
5	LOCK-SCREW	SS	4A0461-01	1												
6	GASKET-DOOR(HALF)	JARROW #P-2209 244A GRAY	3A0273-02	1												
7	LOCK-WASHER	SS	4A0459-01	1												
8	LOCK-KEY	M5-0680-111	4A0460-01	1												
9	WASHER-DOOR LOCK	SS	4A0670-01	1												
10	HINGE-SPRING	-	4A3312-01	1												
11	HINGE-SPRING CART	-	4A0438-01	1												

Q. Door - Half (LR)
 PTR1-SSB01-10
 M-5, N-6, P-5, Q-5

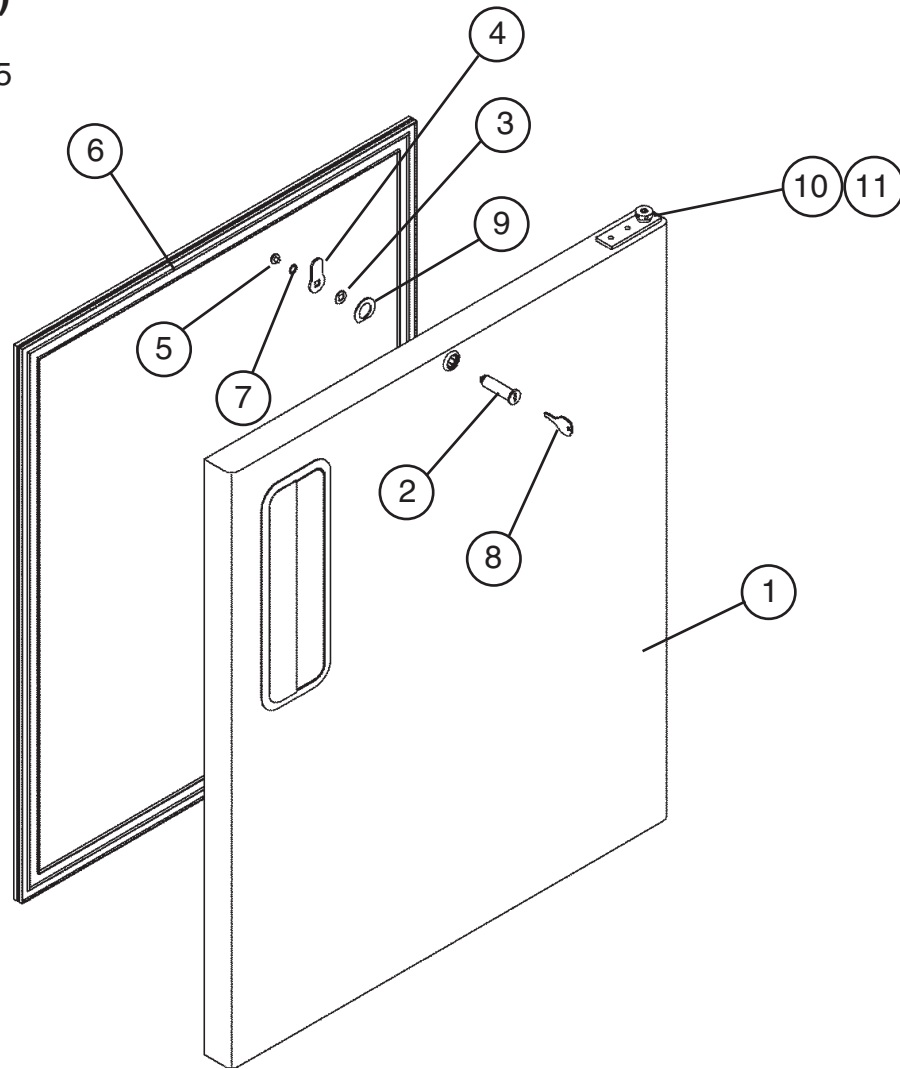

Title: Q. Door - Half (LR) Model: PTR1-SSB01-10																	
Index No.	Description	Material or Model Number	Part Number	Required Number													
				M-5 to Q-5													
1	DOOR-PREFOAM (LR)	-	1A0323G03	1													
2	LOCK-TUMBLER	M4-5813-001	4A0462-01	1													
3	LOCK-STOP WASHER	M5-8060-103	4A0458-01	1													
4	CAM-DOOR LOCK	P.S	4A0228-01	1													
5	LOCK-SCREW	SS	4A0461-01	1													
6	GASKET-DOOR (HALF)	JARROW #P-2209 244A GRAY	3A0273-02	1													
7	LOCK-WASHER	SS	4A0459-01	1													
8	LOCK-KEY	M5-0680-111	4A0460-01	1													
9	WASHER-DOOR LOCK	SS	4A0670-01	1													
10	HINGE-SPRING	-	4A3312-01	1													
11	HINGE-SPRING CART	-	4A0438-01	1													

R. Mullion - Horizontal

PTR1-SSB01-10

M-5, N-6, P-5, Q-5

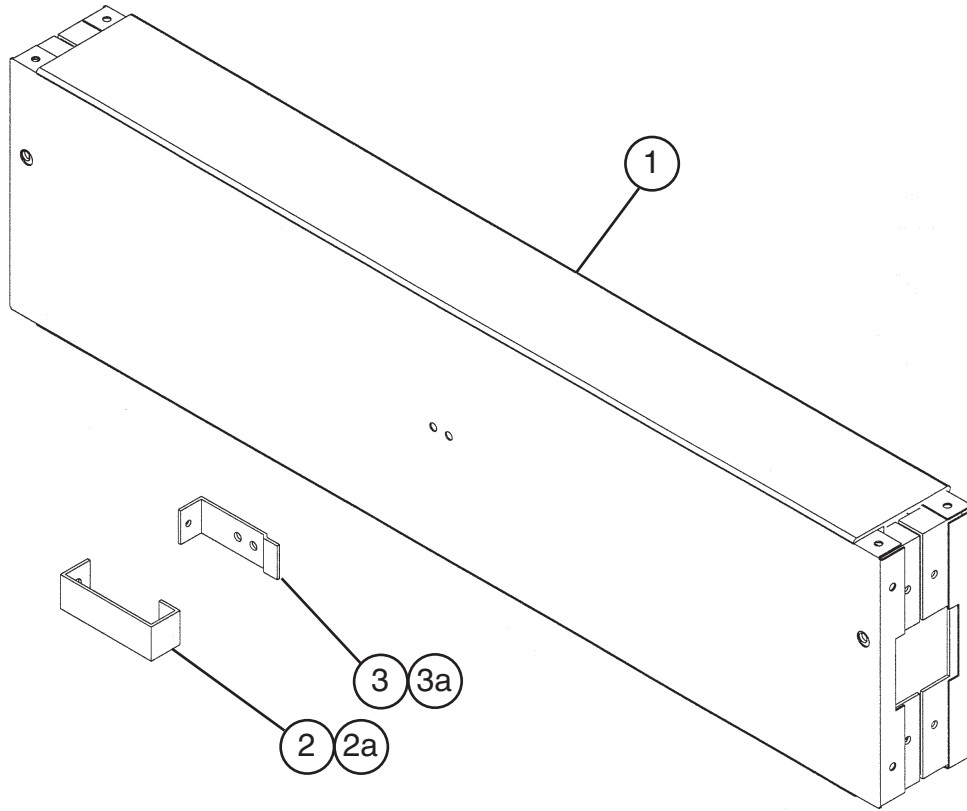

Title: R. Mullion - Horizontal Model: PTR1-SSB01-10					Required Number							
Index No.	Description	Material or Model Number	Part Number	M-5 to Q-5								
1	MULLION-PREFOAM (H)	-	2A1313G06	1								
2	PLATE-STRIKE (ront)	SS	4A0355-01	1								
2a	TRUSSHEAD SCREW	4x8,SS	7C32-0408	1								
3	PLATE-STRIKE (BASE)	SS	4A0354-01	1								
3a	T2 SCREW	4x8,SS	7P32-0408	2								

S. Literature & Packaging

PTR1-SSB01-10

M-5, N-6, P-5, Q-5

Title: S. Literature & Packaging Model: PTR1-SSB01-10												
Index No.	Description	Material or Model Number	Part Number	Required Number								
				M-5 to Q-5								
1	INSTRUCTION MANUAL	PAPER	91A3GA10A	1								
	PACKAGING (AVAILABLE ONLY FOR MODELS CURRENTLY IN PRODUCTION)		1A0765A07									
1	FILLER – DOOR		4A2977-01	1								
2	PAD – CORNER		3A2598-01	4								
3	POST – CORNER (UC)		3A2603-01	3								
4	POST – CORNER (GD)		3A2623G01	1								
4	SUPPORT – CORNER		3A2596-01	4								
5	T2 SCREW	4X8, SS	7P32-0408	4								
6	BRACKET (A) – OVERFLOW PAN		4A0878-01	1								
7	BRACKET (B) – OVERFLOW PAN		4A0879-01	1								
8	PAN – OVERFLOW		4A2081-01	1								
9	CABLE TIE		8911-0200	1								
10	STOP – DOOR		4A1873-01	2								
11	FLAT WASHER	5/8, USS	7W21I5800	4								
12	HEX HEAD BOLT	No. 5/8-11, UNC, L=2	7B01I5825	4								
13	PALLET		3A2517-01	1								
14	PROTECTOR – HANDLE		3A2597-01	2								
15	CAP – FOLDING		3A2604-04	1								
16	DOOR STOP – 2" CENTER		4A1874-01	2								
17	STABILIZER – DOOR		4A2171-01	2								