



Reliability is a
beautiful thing™

HOSHIZAKI® **REACH-IN**

TempGuard® Model

RFH1-SSB-HD

PARTS LIST

ITEM #: 71228
ISSUED: October 31, 2003
REVISED: July 28, 2005

CONTENTS

Auxiliary Code	3
Note About Ordering Parts	3
Material Abbreviations	4
A. Reach-In.....	5
B. Refrigeration System	8
C. Control Panel Assembly	11
D. Control Box Assembly	12
E. Breaker Box Assembly	14
F. Body-Final.....	15
G. Panel-Front Hinged Assembly.....	17
H. Evaporator Cover Assembly (Freezer)	18
J. Evaporator Cover Assembly (Refrigerator)	19
K. Capacitor Box Assembly	20
L. Label Location	21
M. Evaporator Assembly (Freezer)	22
N. Evaporator Assembly (Refrigerator).....	24
P. Condenser Assembly (Freezer)	26
Q. Condenser Assembly (Refrigerator)	27
R. Body-Prefinal.....	28
S. Door-Half (UR)	30
T. Door-Half (LR)	31
U. Literature and Packaging.....	32

Auxiliary Codes

RFH1-SSB-HD	M-5	October 2002
	N-6	March 2003
	P-5	December 2003
	Q-5	December 2004

Note About Ordering Parts

Most assemblies cannot be ordered as complete units; parts in the assemblies generally must be ordered separately.

Material Abbreviations

ALUMINUM

AL = Aluminum

COPPER

CU = Copper

PLASTIC

ABS = Acrylonitrile -butadiene - styrene
AC = Polyacetal
EVA = Ethylene vinyl acetate
PA = Polyamide = Nylon
PC = Polycarbonate
PE = Polyethylene
PES = Polyester
PETP = Polyethylene terephthalate = Tetlon
PP = Polypropylene
PS = Polystyrene
PTFE = Polytetrafluoroethylene = Teflon
PUR = Polyurethane
PVC = Polyvinyl chloride

RUBBER

VN = Vinyl Nitrile
EPDM = EP rubber
NBR = Nitrile butadiene rubber
NR = Natural rubber
NP = Neoprene
SI.R = Silicone rubber
SY.R = Synthetic rubber
EPH = Epichlorohydrin

STEEL

GS = Galvanized steel
SS = Stainless steel
PS = Plated steel
PAS = Primed steel

AUXILIARY CODE

K-5

Designates the year. "K" indicates the year 2000. Years progress or regress in alphabetical order. "J" is 1999, "L" is 2001, "M" is 2002, and so on. The letters "I" and "O" were skipped.

Designates significant part changes within the same year for this model. Base is 5 and this number advances for each change.

Example: P-6

"P" indicates 2004.

"6" indicates the first significant part change for 2004.

A. Reach-In
RFH1-SSB-HD

M-5, N-6, P-5, Q-5

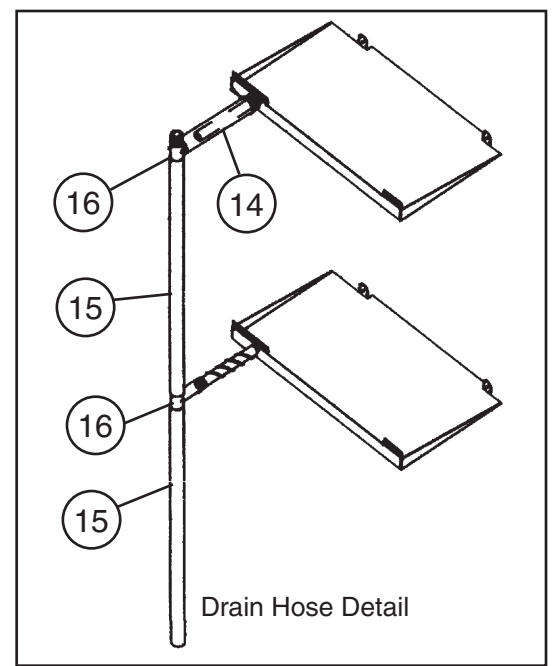
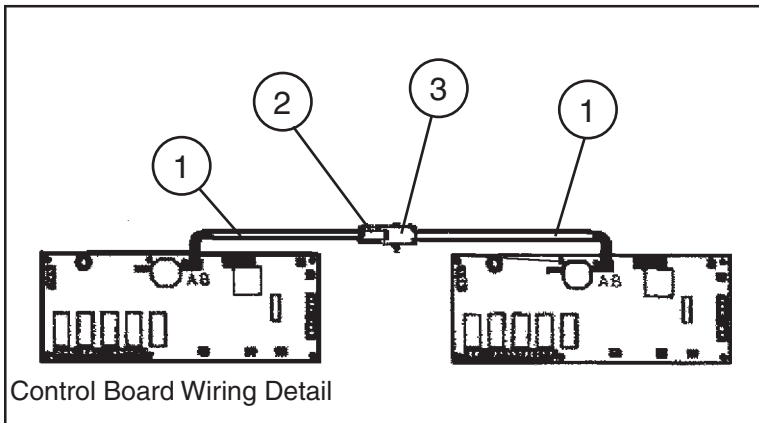
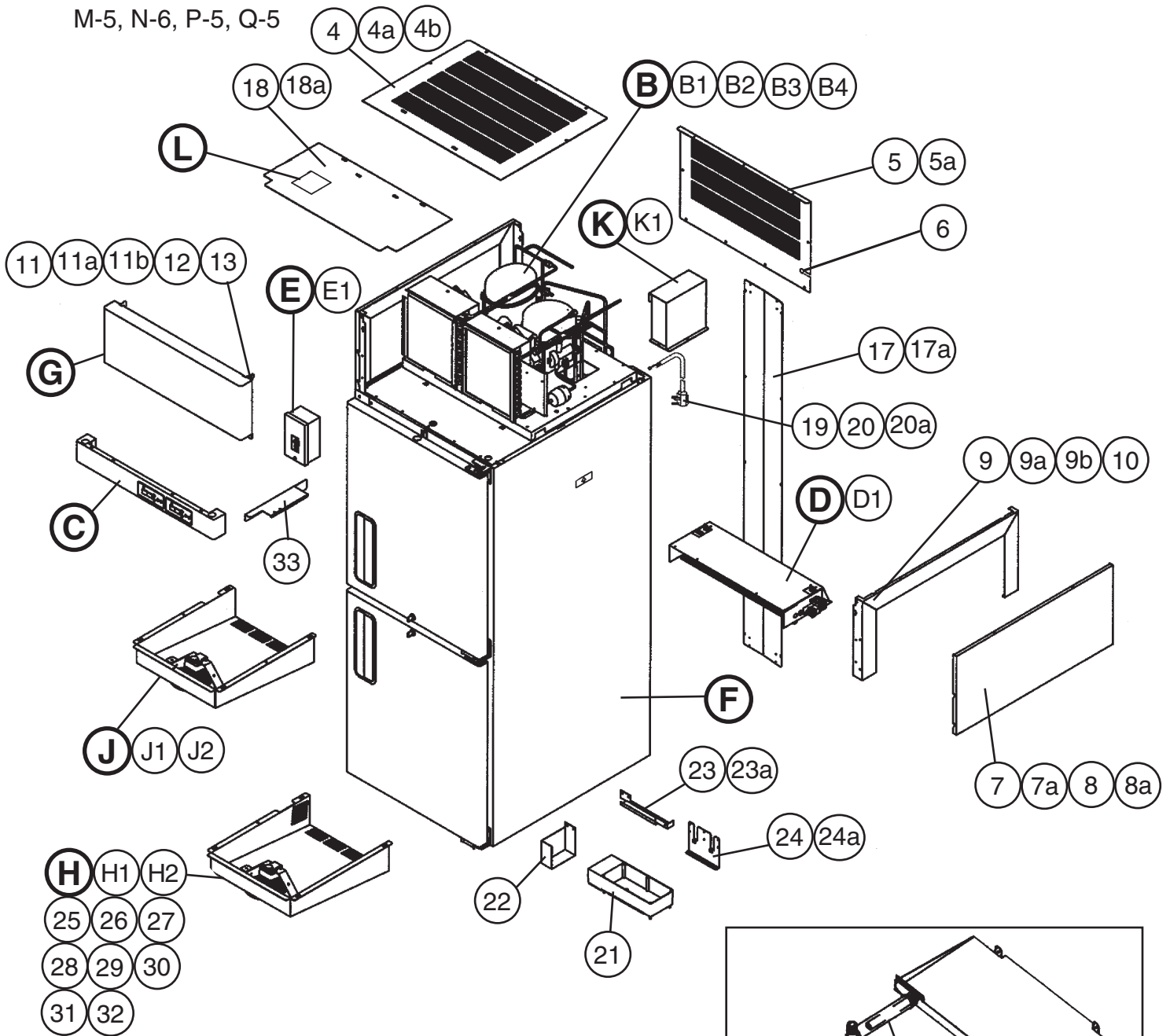

Title: **A. Reach-In** Model: **RFH1-SSB-HD**

Index No.	Description	Material or Model Number	Part Number	Required Number									
				M-5 to P-5	Q-5								
B	Refrigeration Assembly	-	1A0771A01	1	1								
B1	Hex Bolt	8x60	7B01-0860	2	2								
B2	Hex Bolt	8x70	7B01-0870	2	2								
B3	Washer – Flat	8, SS	7W22-0800	8	8								
B4	Split Lock Washer	8, SS	7L22-0800	8	8								
C	Control Panel Assy	-	2A1269A04	1	1								
D	Control Box Assembly		2A2318A01	1	1								
D1	T2 Screw	4x8, SS	7P32-0408	2	2								
E	Box – Breaker Assembly	-	3A1377A02	1	1								
E1	T2 Screw	4x8, SS	7P32-0408	3	3								
F	Body – Final	-	2A2303A01	1	1								
G	Panel – Front Hinged Assembly	-	2A2011A04	1	1								
H	Evaporator Cover Assembly	Freezer	3A2084A02	1	1								
H1	Truss Head Screw	5x10, SS	7C32-0510	5	5								
H2	Insert – Threaded	M5	4A0407-01	7	7								
J	Evaporator Cover Assembly	Refrigerator	3A2084A01	1	1								
J1	Truss Head Screw	5x10, SS	7C32-0510	5	5								
J2	Insert – Threaded	M5	4A0407-01	7	7								
K	Capacitor Box Assembly	-	2A2330A01	1	1								
K1	T2 Screw	4x8, SS	7P32-0408	3	3								
L	Label Location	-	2A1042A10	1	1								
1	Data Cable	L=200	4A1801L01	2	2								
2	Receptacle Housing (2 Pin)	-	412831-07	1	1								
3	Plug Housing (2 Pin)	-	412832-07	1	1								
4	Cover – UL Top	GS	2A2103-01	1	1								
4a	T2 Screw	4x8, SS	7P32-0408	7	7								
4b	Truss Head Screw	5x10, SS	7C32-0510	2	2								
5	Cover – UL Rear	GS	2A2104-01	1	1								
5a	T2 Screw	4x8, SS	7P32-0408	6	6								
6	Bushing	-	428394-03	1	1								
7	Taper Collar	SS	4H0171-01	4	4								
7a	Screw Countersunk	5x20, SS	7C42-0520	4	4								
8	Panel – Side Top	SS	2A1800-01	2	2								
8a	Truss Head Screw	5x10, SS	7C32-0510	2	2								
9	Frame – Side Top	GS	2A1803-01	2	2								
9a	Truss Head Screw	5x10, SS	7C32-0510	8	8								
9b	T2 Screw	4x8, SS	7P32-0408	4	4								
10	Insert – Threaded	M5	4A0407-01	4	4								
11	Bracket – Hinge	GS	4A2306-01	2	2								
11a	Clevis Pin	-	8907-0102	2	2								
11b	Cotter Pin	-	8907-0103	2	2								

Title: **A. Reach-In** Model: **RFH1-SSB-HD**

Index No.	Description	Material or Model Number	Part Number	Required Number									
				M-5 to P-5	Q-5								
12	Flat Washer	-	4A0655-03	2	2								
13	Spacer – Hinge	-	4A2473-01	2	2								
14	Vinyl Hose	L=140	7716-2025	2	1								
15	Vinyl Hose	L=725	7716-2025	2	2								
16	Tee	-	4A2600-01	2	2								
17	Cover – Rear	-	3A1855-01	1	1								
17a	T2 Screw	4x8, SS	7P32-0408	18	18								
18	Cover – UL Front	-	2A2331-01	1	1								
18a	T2 Screw	4x8, SS	7P32-0408	2	2								
19	Power Cordset	-	4A1543-01	1	1								
20	Wire Clamp	-	4A0809-03	1	1								
20a	T2 Screw	4x8, SS	7P32-0408	1	1								
21	Pan – Heated Drain	-	3A2064-01	1	1								
22	Cover – Heated Pan	-	4A2950-01	1	1								
23	Cover – Heater Wire	-	4A2949-01	1	1								
23a	T2 Screw	4x8, SS	7P32-0408	3	3								
24	Bracket – Pan	-	3A2062-01	1	1								
24a	T2 Screw	4x8, SS	7P32-0408	6	6								
25	Connector – Female 6 Pin		4A3468-01		1								
26	Terminal – Pin		4A3472-01		4								
27	Connector – Male 6 Pin		4A3469-01		1								
28	Terminal – Socket		4A3473-01		4								
29	Seal – Connector Wire		4A3470-01		2								
30	Seal – Connector Mating		4A3471-01		1								
31	Bushing – Cut	-	4A2952G01	1	1								
32	Truss Head Screw	5x10, SS	7C32-0510	2	2								
33	Cover Wire	-	4A2952-01	1	1								

B. Refrigeration Assembly
RFH1-SSB-HD
 M-5, N-6, P-5, Q-5

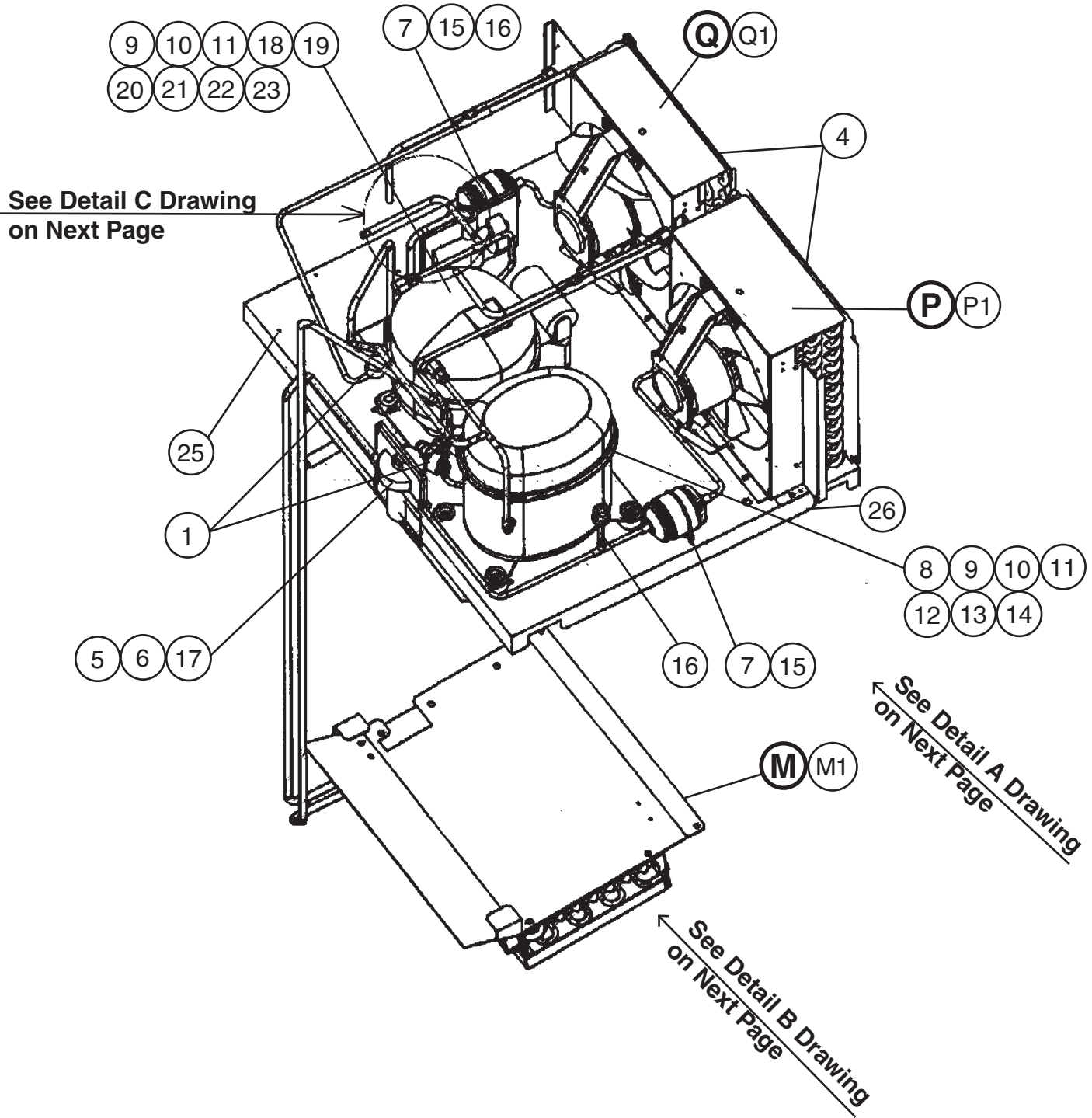

B. Refrigeration Assembly (Details)

RFH1-SSB-HD

M-5, N-6, P-5, Q-5

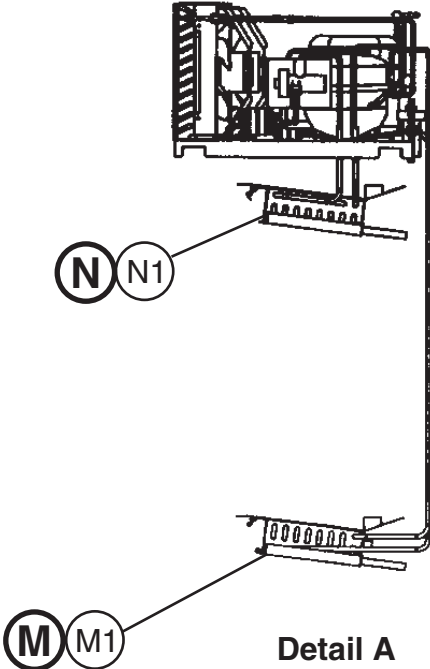

Detail A

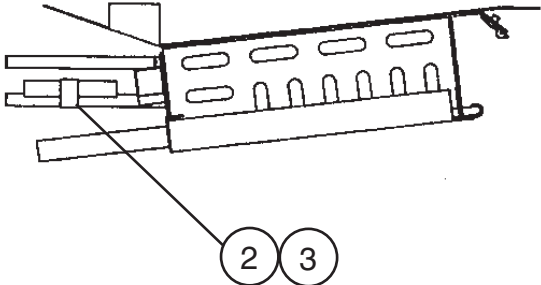

Detail B

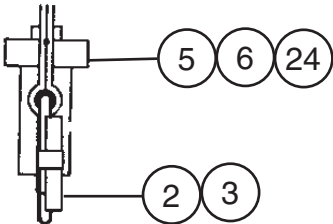

Detail C

Title: B. Refrigeration Assembly Model: RFH1-SSB-HD												
Index No.	Description	Material or Model Number	Part Number	Required Number								
				M-5 to Q-5								
M	Evaporator Assembly	Freezer	3A2083A01	1								
M1	Truss Head Screw	5×10, SS	7C32-0510	2								
N	Evaporator Assembly	Refrigerator	3A2083A02	1								
N1	Truss Head Screw	5×10, SS	7C32-0510	2								
P	Condenser Assembly	Freezer	3A0724A03	1								
P1	T2 Screw	4×8, SS	7P32-0408	4								
Q	Condenser Assembly	Refrigerator	3A1087A03	1								
Q1	T2 Screw	4×8, SS	7P32-0408	4								
1	Thermostat – Clean Filter	-	4A0484-01	2								
2	Hose Clamp	-	443461-01	2								
3	Holder/Exp. Valve	-	3A0107-01	2								
4	Filter – Cond	-	3A0277-01	2								
5	Expansion Valve Cover (A)	-	3A0372-01	2								
6	Expansion Valve Cover (B)	-	3A0372-02	2								
7	Nylon Tie	-	8911-0301	2								
8	Compressor	-	4A2369-01	1								
9	Hex Bolt	8×45	7B01-0845	6								
10	Washer – Flat	8, SS	7W22-0800	6								
11	Split Lock Washer	8, SS	7L22-0800	6								
12	Grommet – Compressor		4A2593-01	4								
13	Spacer – Compressor		4A2595-01	4								
14	Protector		4A2634-01	1								
15	Drier	-	4A0924-01	2								
16	Switch – Pressure	-	4A2516-02	2								
17	Valve – Expansion	-	4A2592-01	1								
18	Compressor	-	4A2343-01	1								
19	Grommet		4A2281-01	4								
20	Spacer		4A2282-01	4								
21	Protector		4A2499-02	1								
22	Relay – Start		4A2368-01	1								
23	Capacitor – Start		4A2367-01	1								
24	Valve – Expansion	-	4A1594-01	1								
25	Clamp	-	427902-05	11								
26	Base – Refrigeration	-	3A2556G01	1								

C. Control Panel Assembly

RFH1-SSB-HD

M-5, N-6, P-5, Q-5

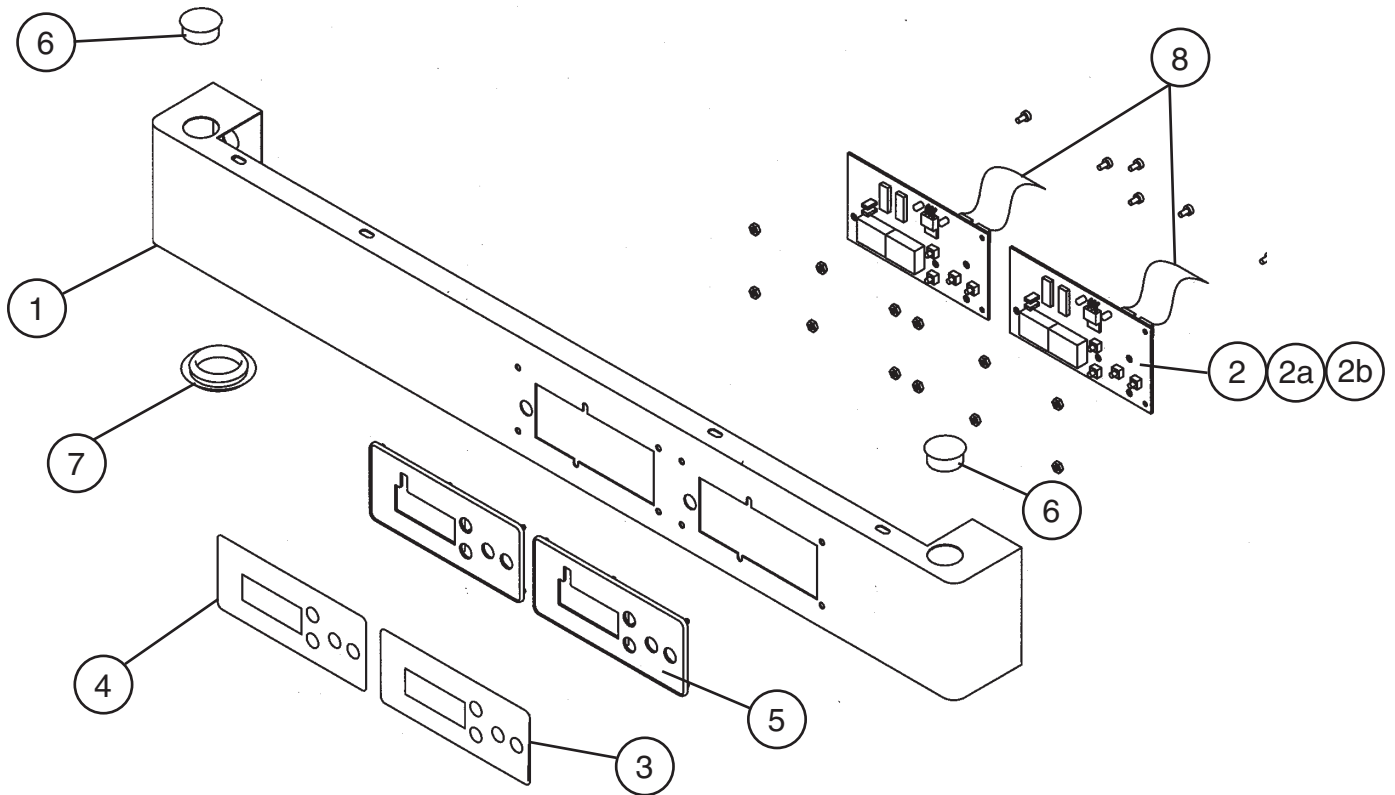

Title: C. Control Panel Assembly		Model: RFH1-SSB-HD		Required Number									
Index No.	Description	Material or Model Number	Part Number	M-5	N-6	P-5	Q-5						
1	Panel – Control	-	1A0625G02	1	1	-							
			1A0760-02			1	1						
2	Board – Display	Control Products 3287A000	2A0883-01	2	2	2	2						
2a	Nylon Screw	-	4A1397-01	8	8	8	8						
2b	Palnut	-	4A1398-01	12	12	12	12						
3	Label – Display	PC	4A1558-02	1	-								
			3A2850-02		1	1	1						
4	Label – Display	PC	4A1558-01	1	-								
			3A2850-01		1	1	1						
5	Mount – Display Board	PC	3A0823-01	2	2	2	2						
6	Locking Hole Plug	-	4A0586-03	2	2	2	2						
7	Plug – Hole	-	4A0420-02	1	1	1	-						
	Locking Hole Plug	-	4A0586-02				1						
8	Ribbon Cable	Control Products D-HA-104	4A1106-01	2	2	2	2						

D. Control Box Assembly
RFH1-SSB-HD
 M-5, N-6, P-5, Q-5

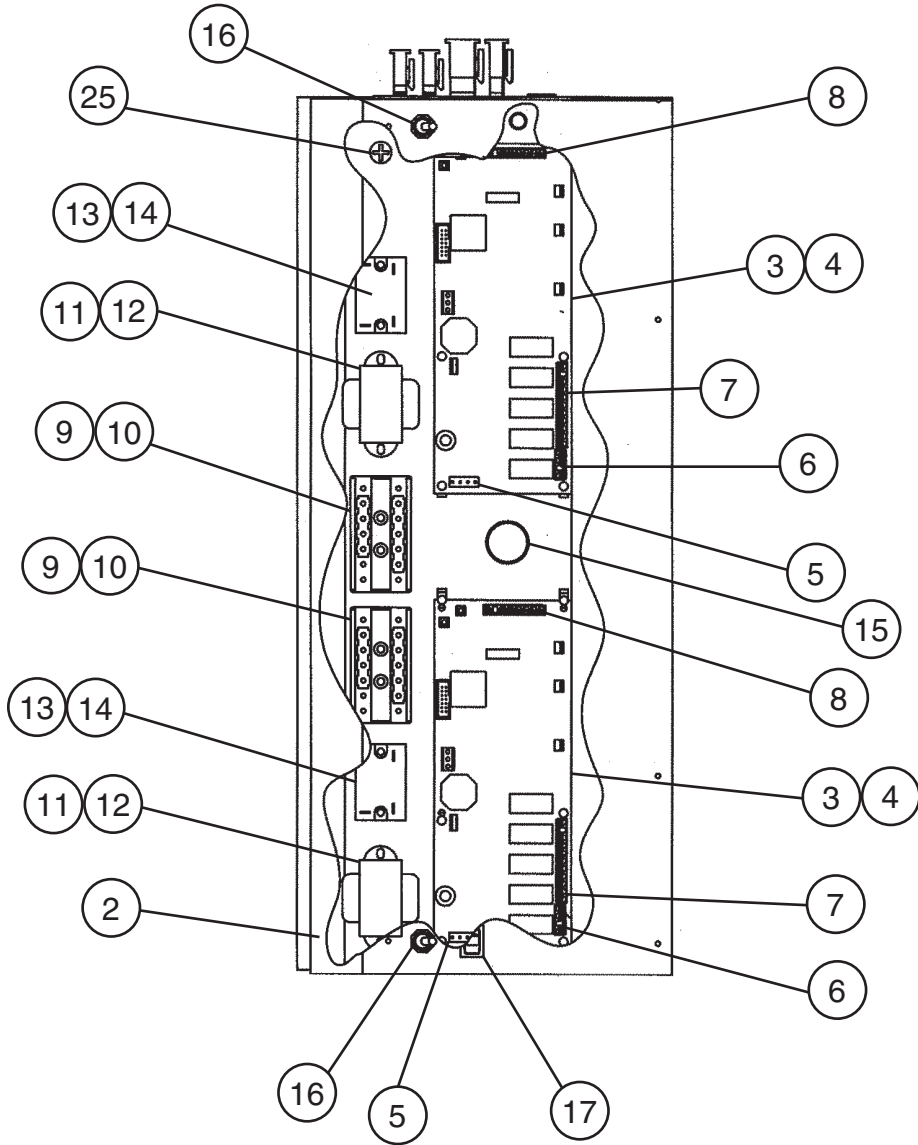
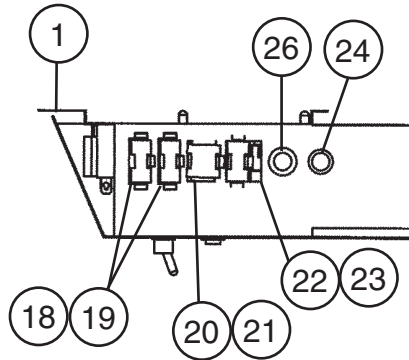

Title: D. Control Box Assembly Model: RFH1-SSB-HD											
Index No.	Description	Material or Model Number	Part Number	Required Number							
				M-5 to P-5	Q-5						
1	Base – Control Box		2A2719-01	1	-						
			2A2719-02		1						
2	Cover – Control Box		2A2715-01	1	-						
			2A2715-02		1						
3	Board – Control	Use latest for all aux. codes	2A2356-01	2	-						
			2A2862-21		2						
4	Board Support		4A0336-03	12	12						
5	Board Connector		434003-09	2	2						
6	Board Connector		434003-11	2	2						
7	Board Connector		434003-05	2	2						
8	Board Connector		434003-07	2	2						
9	Terminal Block		4A2619-01	2	2						
10	Tapping Screw	3x8	431415-01	4	4						
11	Transformer		3A1759-01	2	2						
12	Tapping Screw	3x8	431415-01	4	4						
13	Compressor – Relay		4A1307-01	2	2						
14	Tapping Screw	3x8	431415-01	4	4						
15	Bushing		420470-03	1	1						
16	Switch – Toggle		4A0424-01	2	2						
17	Switch – Rocker		4A0418-01	1	1						
18	Plug Housing		4A0425-01	2	2						
19	Receptacle Housing		4A0426-01	2	2						
20	Plug Housing (6 Pin)		412832-03	1	1						
21	Receptacle Housing (6 Pin)		412831-03	1	1						
22	Plug Housing (9 Pin)		412832-02	1	1						
23	Receptacle Housing (9 Pin)		412831-02	1	1						
24	Bushing		420470-01	1	1						
25	Grounding Screw	M5	433304-02	1	1						
26	Bushing		428394-04	1	1						

E. Breaker Box Assembly

RFH1-SSB-HD

M-5, N-6, P-5, Q-5

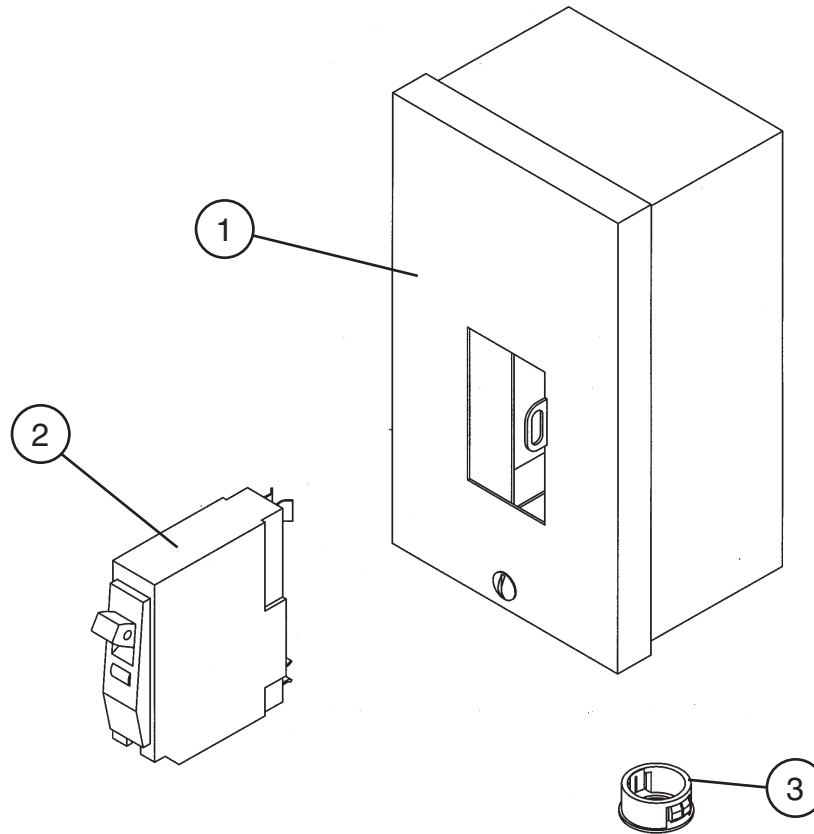

Title: E. Breaker Box Assembly Model: RFH1-SSB-HD													
Index No.	Description	Material or Model Number	Part Number	Required Number									
				M-5 to Q-5									
1	Box – Breaker	-	3A1375-01	1									
2	Circuit – Breaker	-	4A1932-02	1									
3	Bushing	-	428394-04	1									

F. Body-Final
RFH1-SSB-HD
M-5, N-6, P-5, Q-5

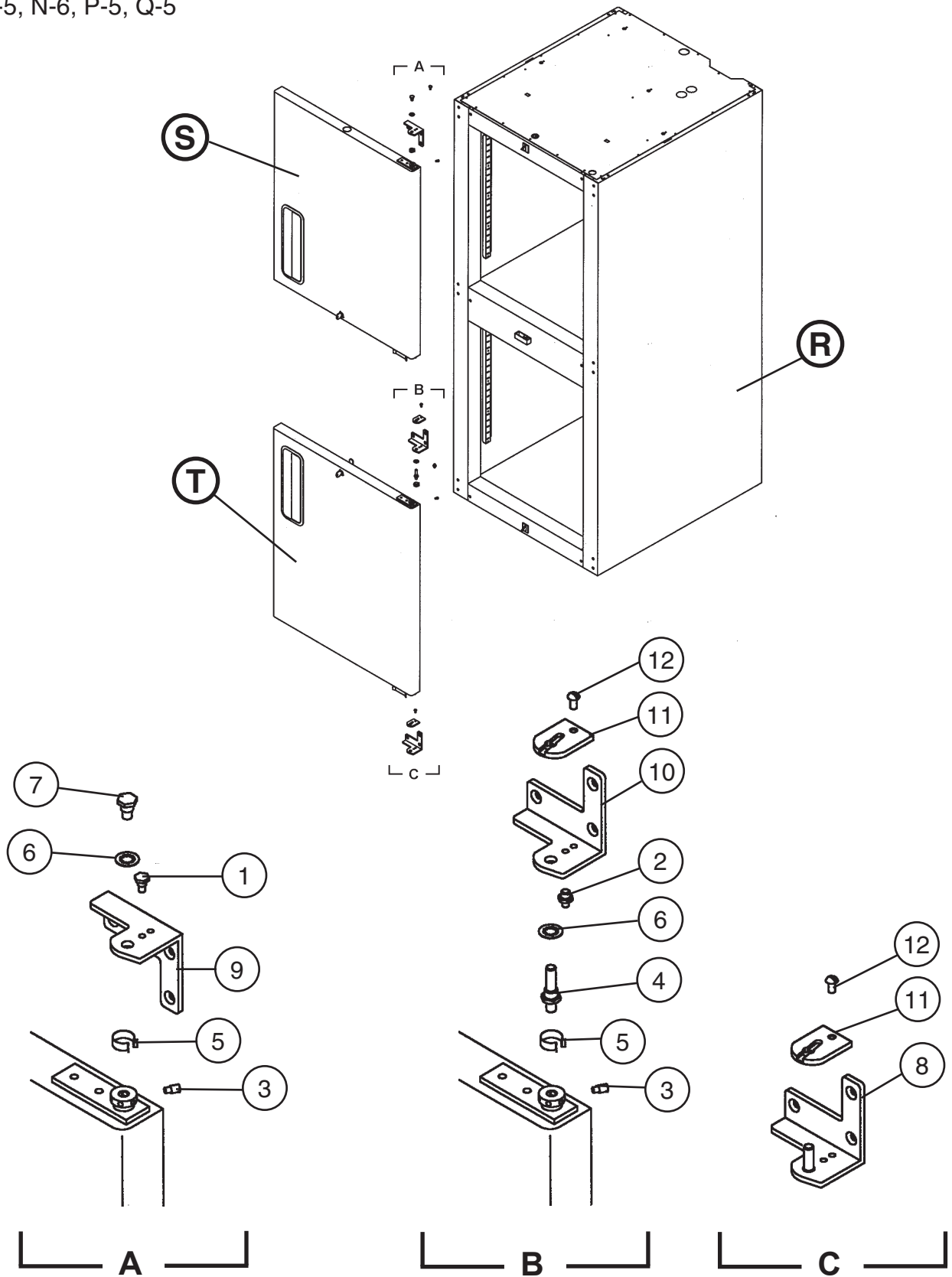

Title: F. Body-Final Model: RFH1-SSB-HD												
Index No.	Description	Material or Model Number	Part Number	Required Number								
				M-5 to Q-5								
R	Body – Prefinal	-	2A2302A01	1								
S	Door – Half (UR)	-	1A0326A03	1								
T	Door – Half (LR)	-	1A0324A03	1								
1	Hinge – Stop Pin	PS	4A2180-01	1								
2	Stop Pin	PS	4A1734-01	1								
3	Hinge – Tension Screw	SS	4A0446-01	2								
4	Pivot Pin	PS	4A1735-01	1								
5	Hinge – Bushing Cover	PS	4A0445-01	2								
6	Hinge – Lock Washer	PS	4A0553-01	2								
7	Hinge – Pivot Pin (Top)	PS	4A2179-01	1								
8	Bracket – Door Hinge (LR)	PS	3A1626-01	1								
9	Bracket – Door Hinge (UR)	PS	3A1580-01	1								
10	Bracket – Door Hinge (UL)	PS	3A1581-01	1								
11	Hinge – Stop Plate (R)	PS	4A0441-01	2								
12	Screw – Stop Plate	PS	4A0483-01	2								

G. Panel-Front Hinged Assembly

RFH1-SSB-HD

M-5, N-6, P-5, Q-5

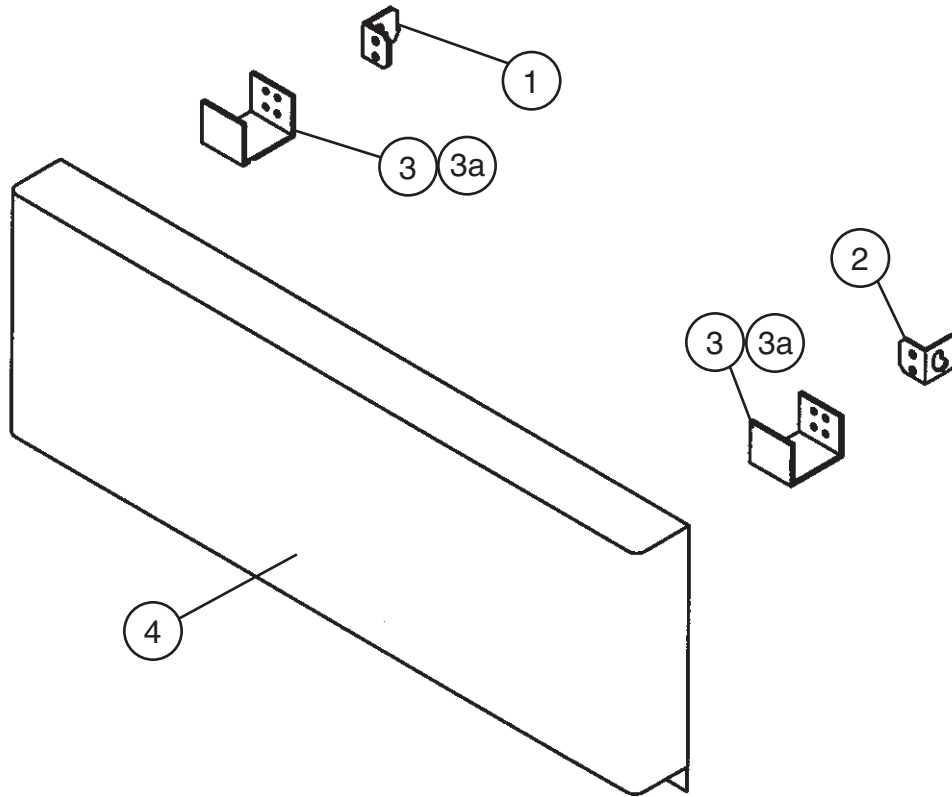

Title: G. Panel-Front Hinged Assembly Model: RFH1-SSB-HD					Required Number								
Index No.	Description	Material or Model Number	Part Number	M-5 to Q-5									
					1	Hinge – Front Panel (L)		4A2153-01	1				
2	Hinge – Front Panel (R)		4A2154-01	1									
3	Channel – Hinge		4A2170-01	2									
3a	Truss Head Screw	5x8, SS	7C32-0508	4									
4	Panel – Front		1A0624-04	1									

H. Evaporator Cover Assembly (Freezer)

RFH1-SSB-HD

M-5, N-6, P-5, Q-5

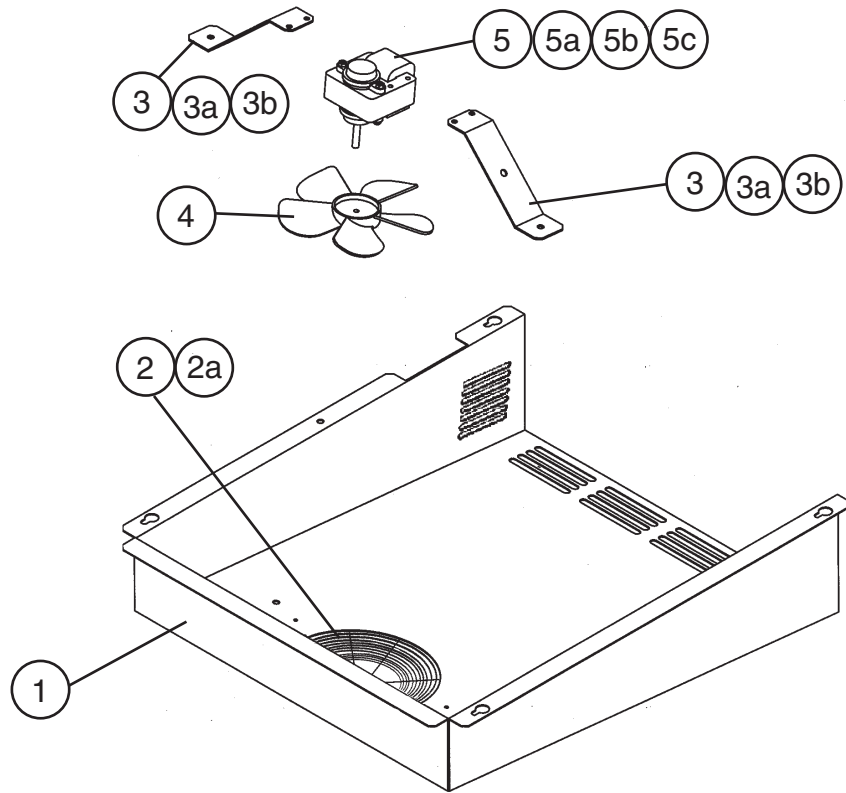

Title: H. Evaporator Cover Assembly (Freezer) Model: RFH1-SSB-HD					Required Number								
Index No.	Description	Material or Model Number	Part Number	M-5 to Q-5									
1	Cover – Evaporator	-	2A2105-02	1									
2	Grill – Fan	-	4A2565-01	1									
2a	T2 Screw	4x8, SS	7P32-0408	2									
3	Bracket – Fan Motor	-	3A2074-01	2									
3a	Insert Threaded	M5	4A0407-01	2									
3b	Truss Head Screw	5x8, SS	7C32-0508	2									
4	Blade – Fan	-	4A2590-01	1									
5	Motor Fan Evaporator	-	4A2563-01	1									
5a	Truss Head Screw	4x30, SS	7C32-0430	4									
5b	Hex Nut	M4, SS	7N12-0400	4									
5c	Split Lock Washer	M4, SS	7L22-0400	4									

J. Evaporator Cover Assembly (Refrigerator)

RFH1-SSB-HD

M-5, N-6, P-5, Q-5

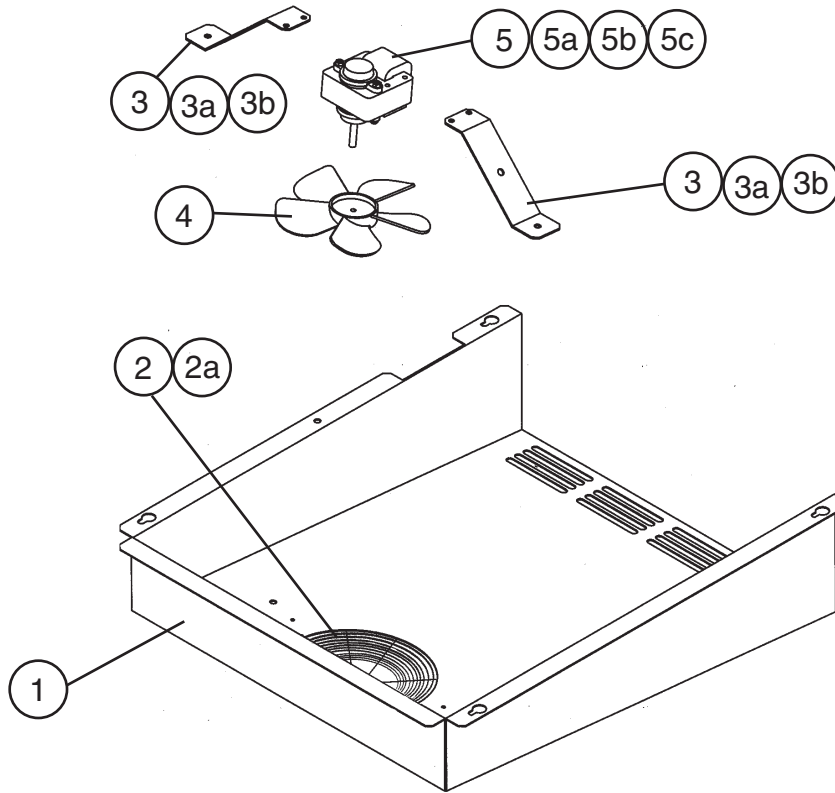

Title: J. Evaporator Cover Assembly (Refrigerator) Model: RFH1-SSB-HD					Required Number								
Index No.	Description	Material or Model Number	Part Number	M-5 to Q-5									
1	Cover – Evaporator	-	2A2105-01	1									
2	Grill – Fan	-	4A2565-01	1									
2a	T2 Screw	4x8, SS	7P32-0408	2									
3	Bracket – Fan Motor	-	3A2074-01	2									
3a	Insert Threaded	M5	4A0407-01	2									
3b	Truss Head Screw	5x8, SS	7C32-0508	2									
4	Blade – Fan	-	4A2590-01	1									
5	Motor Fan Evaporator	-	4A2563-01	1									
5a	Truss Head Screw	4x30, SS	7C32-0430	4									
5b	Hex Nut	M4, SS	7N12-0400	4									
5c	Split Lock Washer	M4, SS	7L22-0400	4									

K. Capacitor Box Assembly

RFH1-SSB-HD

M-5, N-6, P-5, Q-5

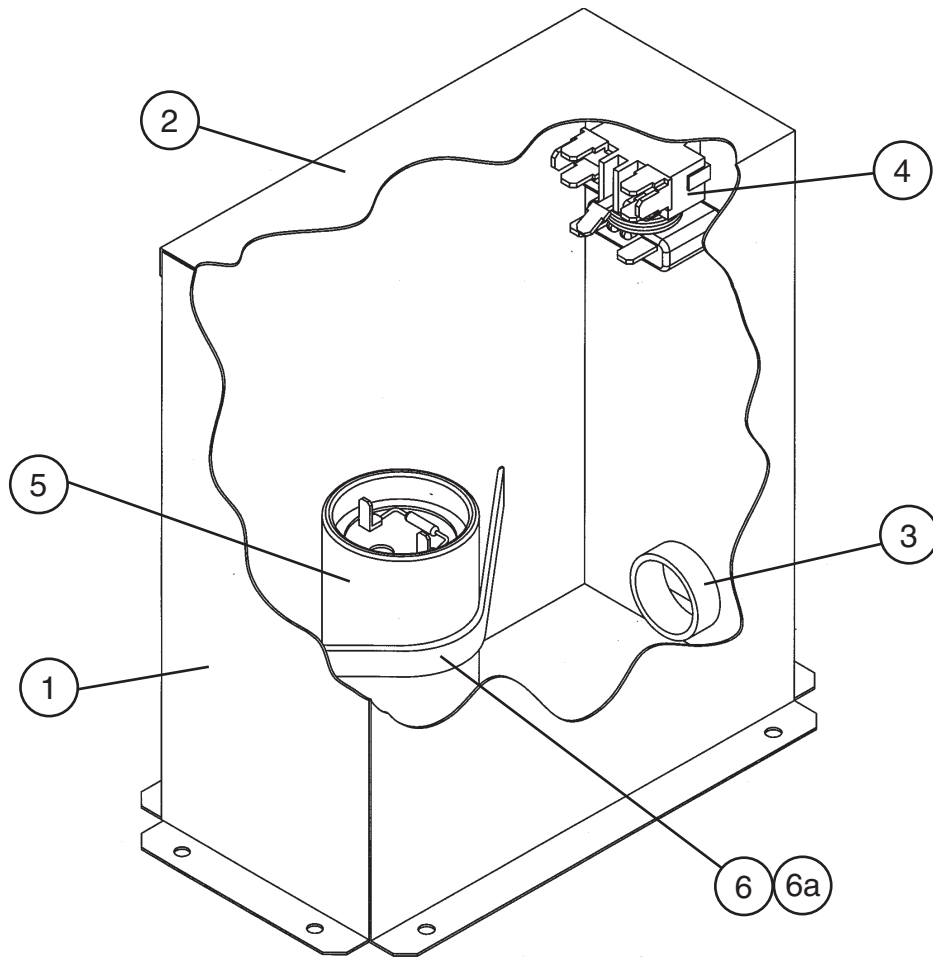

Title: K. Capacitor Box Assembly Model: RFH1-SSB-HD										
Index No.	Description	Material or Model Number	Part Number	Required Number						
				M-5 to Q-5						
1	Base – Capacitor Box		3A2082-01	1						
2	Cover – Capacitor Box		3A2081-01	1						
3	Bushing		420470-03	1						
4	Relay – Start		4A2370-01	1						
5	Capacitor – Start		4A2668-01	1						
6	Strap		434580-05	1						
6a	T2 Screw	4x8, SS	7P32-0408	1						

L. Label Location
RFH1-SSB-HD
M-5, N-6, P-5, Q-5

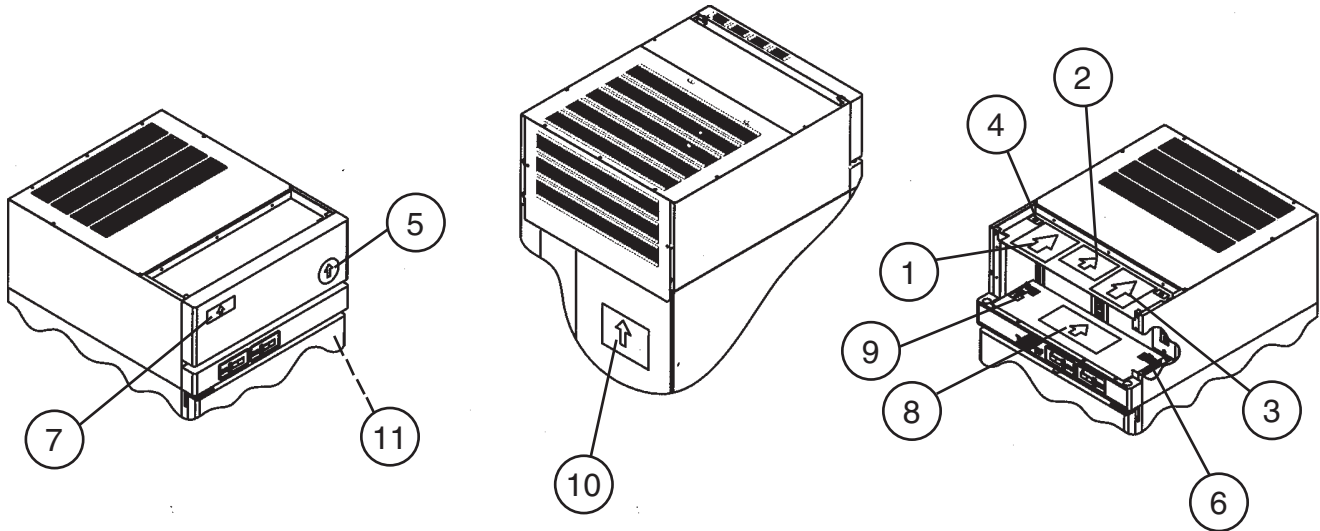

Title: L. Label Location		Model: RFH1-SSB-HD		Required Number										
Index No.	Description	Material or Model Number	Part Number	M-5	P-5	Q-5								
				to										
1	Wiring Label		2A2327-01	1	1									
2	Wiring Label		2A2329-01	1	1									
3	Wiring Label		3A2112-01	1	1									
4	Label – R404A		4A0960-01	2	2									
5	Label – Penguin – HA (L)		4A0526-02	1	1									
6	Label – On/Off		4A0522-01	2	2									
7	Emblem – Hoshizaki		4A0560-01	1	1									
8	Label – Display Info		3A1413-01	1	1									
9	Label – Door Heater Switch		4A1039-01	1	1									
10	Caution Label		4A1931-01	1	1									
11	Cover – Nameplate		4A3727-01		1									

M. Evaporator Assembly (Freezer)

RFH1-SSB-HD

M-5, N-6, P-5, Q-5

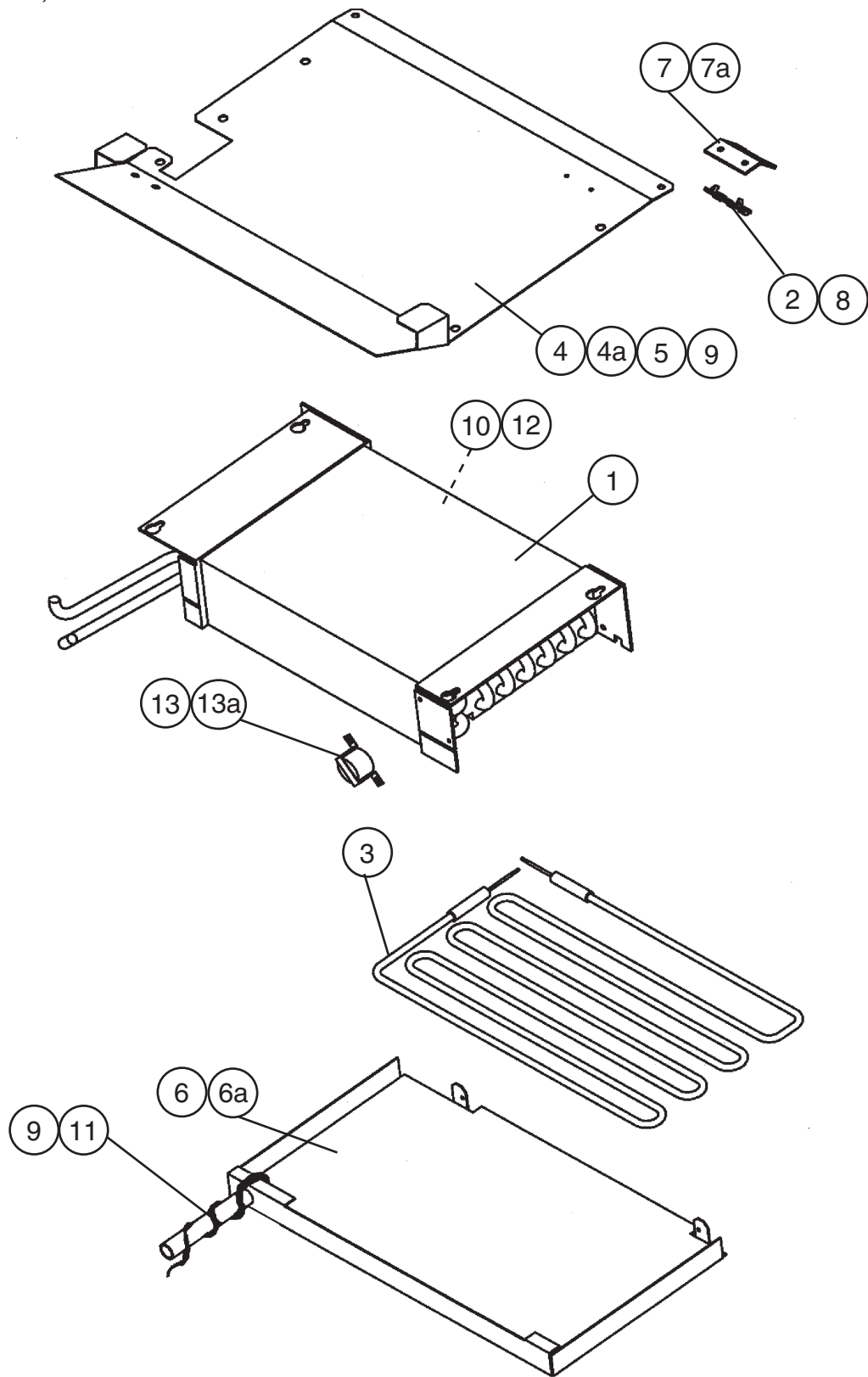

Title: M. Evaporator Assembly (Freezer) Model: RFH1-SSB-HD												
Index No.	Description	Material or Model Number	Part Number	Required Number								
				M-5 to P-5	Q-5							
1	Evaporator		2A2289-01	1	1							
2	Thermistor – Cabinet		4A1429-02	1	1							
3	Heater – Defrost		3A1849-01	1	1							
4	Mount – Evaporator	-	3A1857-01	1	1							
4a	Truss Head Screw	5x10, SS	7C32-0510	4	4							
5	Insert Threaded	M5	4A0407-01	4	4							
6	Drain Pan Assembly		4A2579G01	1	1							
6a	T2 Screw	4x8, SS	7P32-0408	2	2							
7	Thermistor Bracket (A)		433964-01	1	1							
7a	T2 Screw	4x8, SS	7P32-0408	2	2							
8	Thermistor Bracket (B)		433920-01	1	1							
9	Wire Saddle	-	4A0338-02		2							
10	Thermistor Clip		320418-01	1	1							
11	Heater – Drain	-	4A2975-01		1							
12	Thermistor – Defrost		4A1428-02	1	1							
13	Thermostat – Defrost		4A0954-02	1	1							
13a	T2 Screw	4x8, SS	7P32-0408	2	2							

N. Evaporator Assembly (Refrigerator)

RFH1-SSB-HD

M-5, N-6, P-5, Q-5

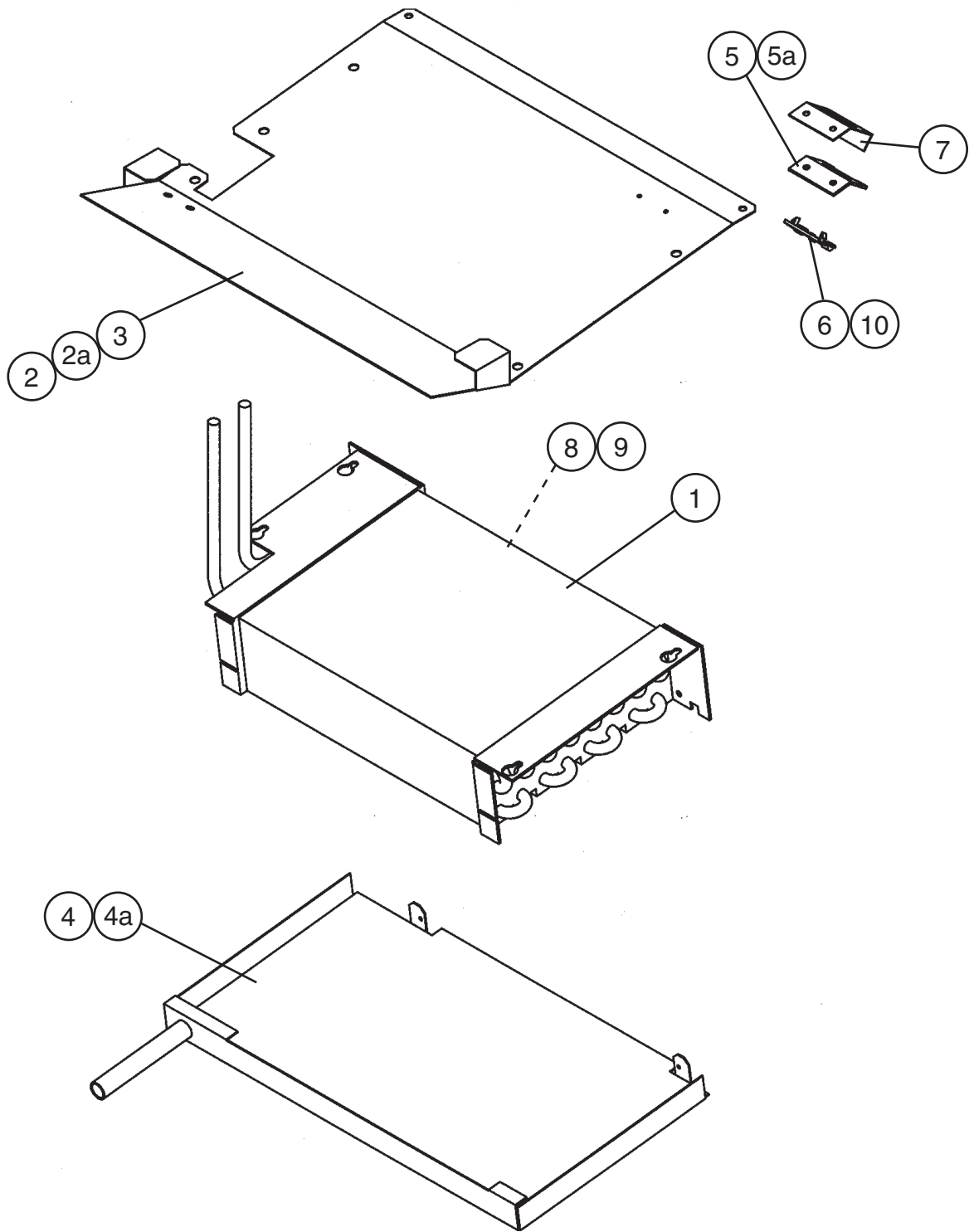

Title: N. Evaporator Assembly (Refrigerator) Model: RFH1-SSB-HD												
Index No.	Description	Material or Model Number	Part Number	Required Number								
				M-5 to Q-5								
1	Evaporator		2A2290-01	1								
2	Mount – Evaporator	-	3A1857-01	1								
2a	Truss Head Screw	5x10, SS	7C32-0510	4								
3	Insert Threaded	M5	4A0407-01	4								
4	Drain Pan Assembly		4A2579G01	1								
4a	T2 Screw	4x8, SS	7P32-0408	2								
5	Thermistor Bracket (A)		4A3004-01	1								
5a	T2 Screw	4x8, SS	7P32-0408	2								
6	Thermistor Bracket (B)		433920-01	1								
7	Shield – Thermistor		4A2057-01	1								
8	Thermistor – Defrost		4A1428-01	1								
9	Thermistor Clip		320418-01	1								
10	Thermistor – Cabinet		4A1429-02	1								

P. Condenser Assembly (Freezer)

RFH1-SSB-HD

M-5, N-6, P-5, Q-5

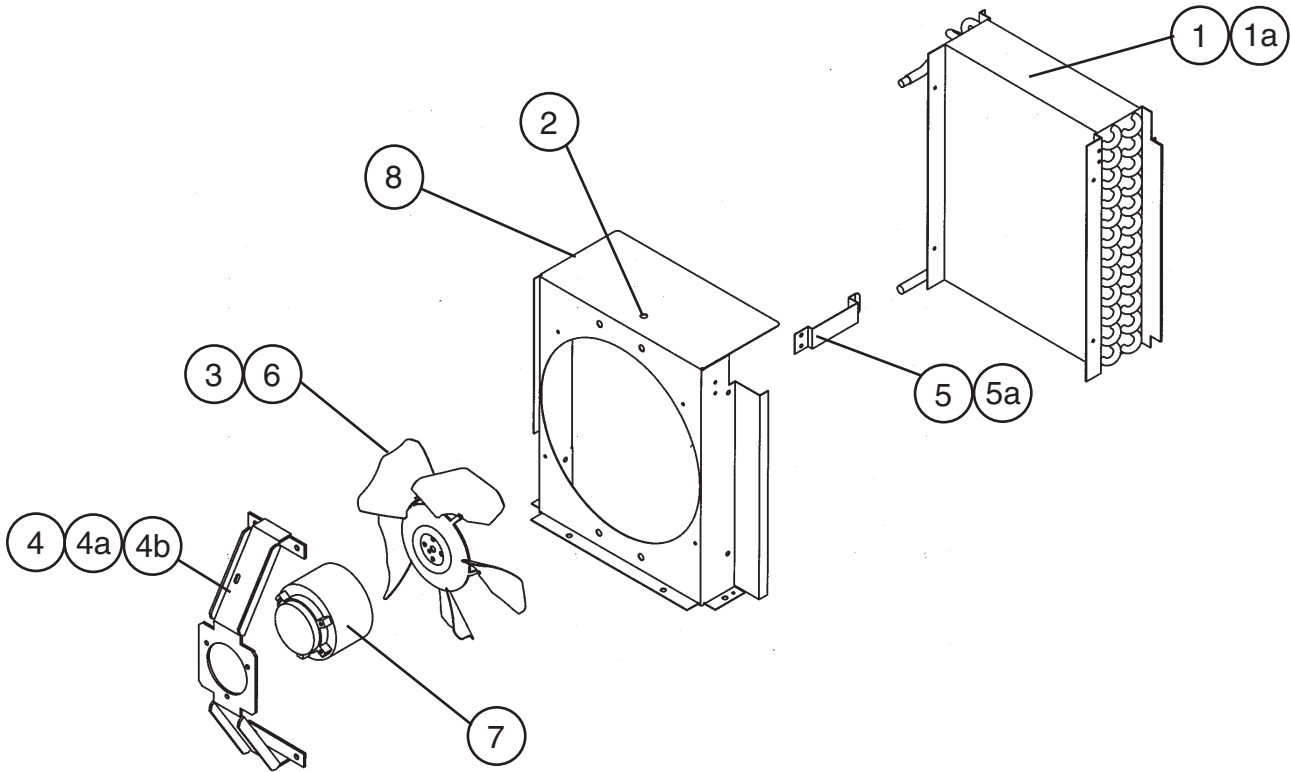

Title: P. Condenser Assembly (Freezer) Model: RFH1-SSB-HD					Required Number							
Index No.	Description	Material or Model Number	Part Number	M-5 to Q-5								
					1	Condenser		2A0782-01	1			
1a	T2 Screw	4x8, SS	7P32-0408	4								
2	Insert – Threaded	M5	4A0407-01	5								
3	Blade – Condenser Fan		3A0608-01	1								
4	Bracket – Condenser Fan		3A1564-01	1								
4a	Truss Head Screw	5x12, SS	7C32-0512	4								
4b	Cable Tie		8911-0200	1								
5	Retainer – Filter		4A0790-01	1								
5a	T2 Screw	4x8, SS	7P32-0408	2								
6	Hex Nut		4A1345-01	1								
7	Fan – Motor		4A1179-01	1								
8	Shroud – Condenser		2A2338-02	1								

Q. Condenser Assembly (Refrigerator)

RFH1-SSB-HD

M-5, N-6, P-5, Q-5

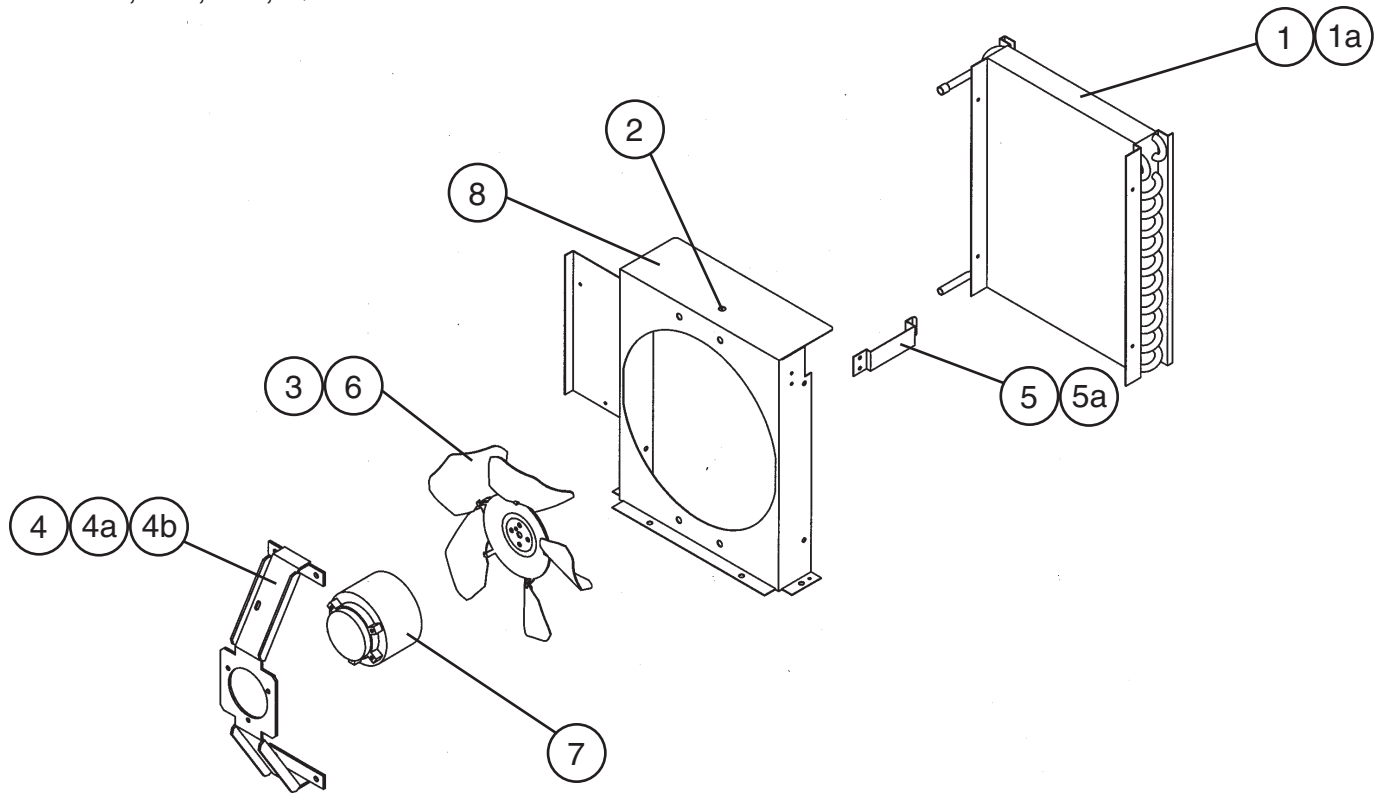

Title: Q. Condenser Assembly (Refrigerator) Model: RFH1-SSB-HD					Required Number							
Index No.	Description	Material or Model Number	Part Number	M-5 to Q-5								
1	Condenser		2A0623-01	1								
1a	T2 Screw	4X8, SS	7P32-0408	4								
2	Insert – Threaded	M5	4A0407-01	5								
3	Blade – Condenser Fan		3A0436-01	1								
4	Bracket – Condenser Fan		3A1564-01	1								
4a	Truss Head Screw	5X12, SS	7C32-0512	4								
4b	Cable Tie		8911-0200	1								
5	Retainer – Filter		4A0790-01	1								
5a	T2 Screw	4X8, SS	7P32-0408	2								
6	Hex Nut		4A1345-01	1								
7	Motor – 9W		4A0408-01	1								
8	Shroud – Condenser		2A2720-01	1								

R. Body-Prefinal
RFH1-SSB-HD
M-5, N-6, P-5, Q-5

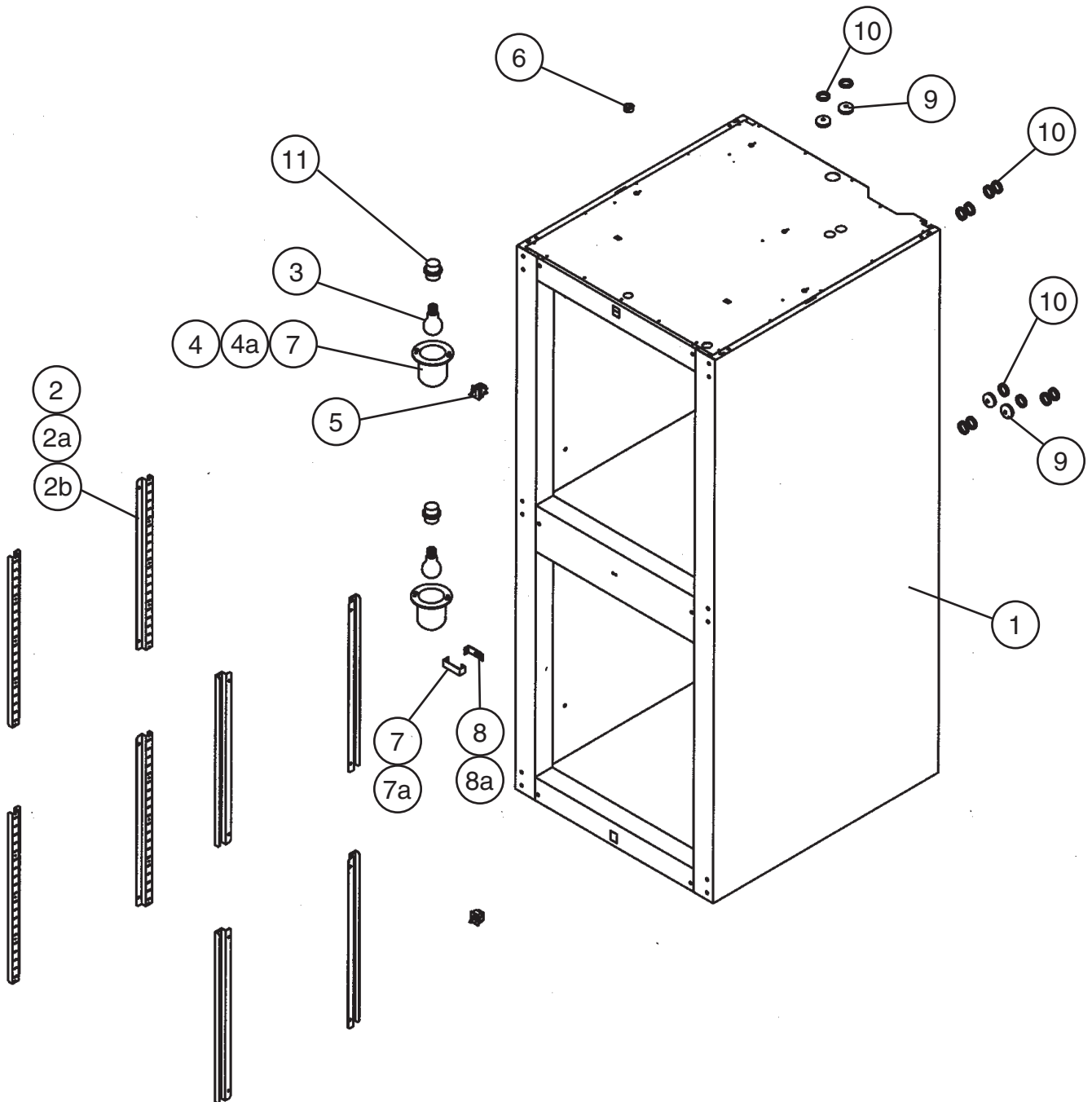

Title: R. Body-Prefinal Model: RFH1-SSB-HD										
Index No.	Description	Material or Model Number	Part Number	Required Number						
				M-5 to Q-5						
1	Cabinet Prefoam	-	2A2301G01	1						
2	Pilaster	SS	3A1334-01	8						
2a	Truss Head Screw	5x10, SS	7C32-0510	16						
2b	Insert – Threaded	M5	4A0407-01	16						
3	Bulb – Light	-	4A2420-01	2						
4	Shield – Light	STANDARD KEIL, 2778-1010-3000	4A0465-01	2						
4a	Cheese Head Screw	5x12, SS	7C52-0512	4						
5	Switch – Door	NYLON	3A1826-01	2						
6	Bushing	-	428394-04	1						
7	Plate – Strike (Front)	-	4A0355-01	1						
7a	Truss Head Screw	4x8, SS	7C32-0408	1						
8	Plate – Strike (Base)	-	4A0354-01	1						
8a	T2 Screw	4x8, SS	7P32-0408	2						
9	Grommets	-	4A2599-01	4						
10	Grommets	-	4A2599-02	12						
11	Lampholder	-	4A2862-01	2						

S. Door-Half (UR)

RFH1-SSB-HD

M-5, N-6, P-5, Q-5

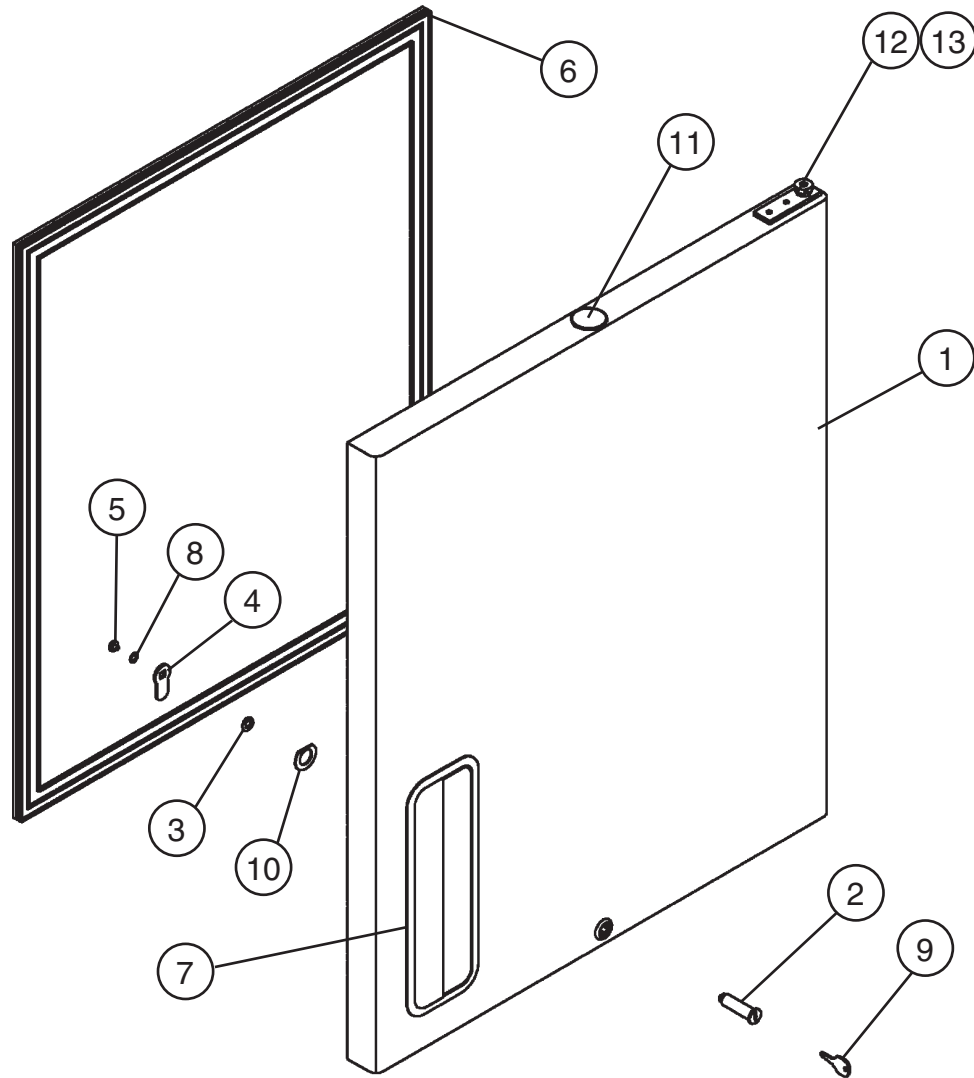

Title: S. Door-Half (UR) Model: RFH1-SSB-HD																	
Index No.	Description	Material or Model Number	Part Number	Required Number													
				M-5 to Q-5													
1	Door – Prefoam (UR)	-	1A0325G03	1													
2	Lock – Tumbler	M4-5813-001	4A0462-01	1													
3	Lock – Stop Washer	M5-8060-103	4A0458-01	1													
4	Cam – Door Lock	P.S	4A0228-01	1													
5	Lock – Screw	SS	4A0461-01	1													
6	Gasket – Door (Half)	Jarrow #P-2209 244A GRAY	3A0273-02	1													
7	Handle – Door	-	3A0252A01	1													
8	Lock Washer	SS	4A0459-01	1													
9	Lock – Key	M5-0680-111	4A0460-01	1													
10	Washer – Door Lock	SS	4A0670-01	1													
11	Locking Hole Plug	-	4A0586-06	1													
12	Hinge – Spring		4A3312-01	1													
13	Hinge – Spring Cart		4A0438-01	1													

T. Door-Half (LR)
RFH1-SSB-HD
M-5, N-6, P-5, Q-5

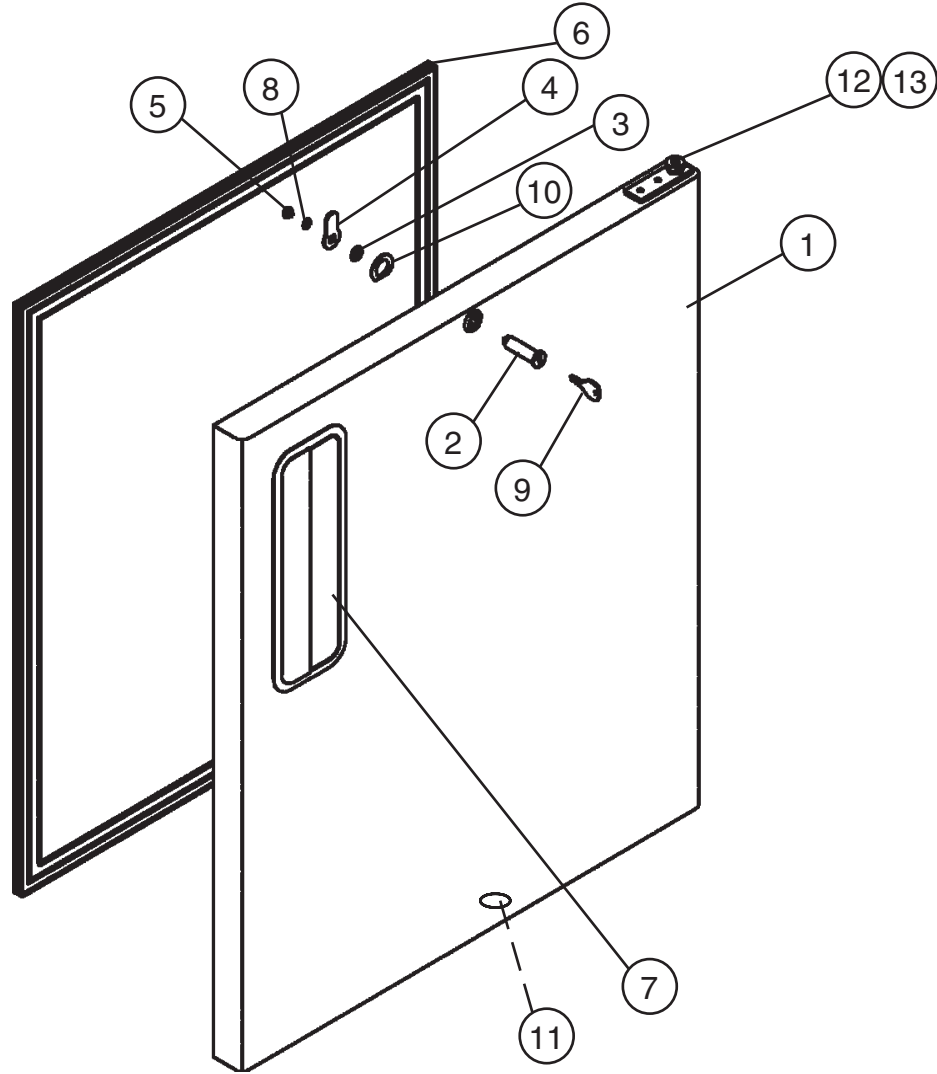

Title: T. Door-Half (LR) Model: RFH1-SSB-HD					Required Number												
Index No.	Description	Material or Model Number	Part Number	M-5 to Q-5													
1	Door – Prefoam (LR)	-	1A0323G03	1													
2	Lock – Tumbler	M4-5813-001	4A0462-01	1													
3	Lock – Stop Washer	M5-8060-103	4A0458-01	1													
4	Cam – Door Lock	P.S	4A0228-01	1													
5	Lock – Screw	SS	4A0461-01	1													
6	Gasket – Door (Half)	Jarrow #P-2209 244A GRAY	3A0273-02	1													
7	Handle – Door	-	3A0252A01	1													
8	Lock Washer	SS	4A0459-01	1													
9	Lock – Key	M5-0680-111	4A0460-01	1													
10	Washer – Door Lock	SS	4A0670-01	1													
11	Locking Hole Plug	-	4A0586-06	1													
12	Hinge – Spring	-	4A3312-01	1													
13	Hinge – Spring Cart	-	4A0438-01	1													

U. Literature and Packaging
RFH1-SSB-HD
M-5, N-6, P-5, Q-5

Title: U. Literature and Packaging Model: RFH1-SSB-HD												
Index No.	Description	Material or Model Number	Part Number	Required Number								
				M-5 to Q-5								
1	Instruction Manual	Paper	91A34010L	1								
Packaging (Available only for models currently in production)			1A0765A06	1								
1	Filler – Door		4A2977-01	2								
2	Pad – Corner		3A2598-01	4								
3	Post – Corner		3A2603-01	4								
4	Support – Corner		3A2596-01	4								
5	Stop – Door		4A1873-01	2								
6	Flat Washer		7W2115800	4								
7	Hex Head Bolt		7B01 I5825	4								
8	Pallet		3A1814-01	1								
9	Pan – Heater Drain		3A2064-01	1								
10	Bracket – Pan		3A2062-01	1								
11	T2 Screw		7P32-0408	6								
12	Shelf (3 Pack)		HS-3508	1								
13	Leg (4 Pack)		HS-3512	1								
14	Protector – Front		3A2064-01	1								