



Reliability is a
beautiful thing™

HOSHIZAKI® **REACH-IN**

SafeTemp® Model

RH1-AAC-W

PARTS LIST

ITEM #: 71226
ISSUED: October 16, 2003
REVISED: August 9, 2005

CONTENTS

Auxiliary Codes.....	3
Note About Ordering Parts	3
Material Abbreviations	4
A. Reach-In.....	5
B. Refrigeration System.....	7
C. Panel-Front Hinged Assembly	10
D. Body-Final	11
E. Control Box Assembly	13
F. Label Location.....	15
G. Fan-Evaporator Assembly.....	16
H. Evaporator Assembly	17
J. Condenser Assembly	18
K. Body-Prefinal.....	20
L. Door-Left.....	22
M. Literature & Packaging.....	24

Auxiliary Codes

RH1-AAC-W	M-5	November 2002
	N-5	December 2002
	N-6	January 2003
	P-5	December 2003
	P-6	October 2004
	P-7	November 2004
	Q-5	December 2004
	Q-6	June 2005

Note About Ordering Parts

Most assemblies cannot be ordered as complete units; parts in the assemblies generally must be ordered separately.

Material Abbreviations

ALUMINUM

AL = Aluminum

COPPER

CU = Copper

PLASTIC

ABS = Acrylonitrile -butadiene - styrene
AC = Polyacetal
EVA = Ethylene vinyl acetate
PA = Polyamide = Nylon
PC = Polycarbonate
PE = Polyethylene
PES = Polyester
PETP = Polyethylene terephthalate = Tetlon
PP = Polypropylene
PS = Polystyrene
PTFE = Polytetrafluoroethylene = Teflon
PUR = Polyurethane
PVC = Polyvinyl chloride

RUBBER

VN = Vinyl Nitrile
EPDM = EP rubber
NBR = Nitrile butadiene rubber
NR = Natural rubber
NP = Neoprene
SI.R = Silicone rubber
SY.R = Synthetic rubber
EPH = Epichlorohydrin

STEEL

GS = Galvanized steel
SS = Stainless steel
PS = Plated steel
PAS = Primed steel

AUXILIARY CODE

K-5

Designates the year. "K" indicates the year 2000. Years progress or regress in alphabetical order.

"J" is 1999, "L" is 2001, "M" is 2002, and so on. The letters "I" and "O" were skipped.

Designates significant part changes within the same year for this model. Base is 5 and this number advances for each change.

Example: P-6

"P" indicates 2004.

"6" indicates the first significant part change for 2004.

A. Reach-In
RH1-AAC-W

M-5, N-5, N-6, P-5, P-6, P-7, Q-5, Q-6

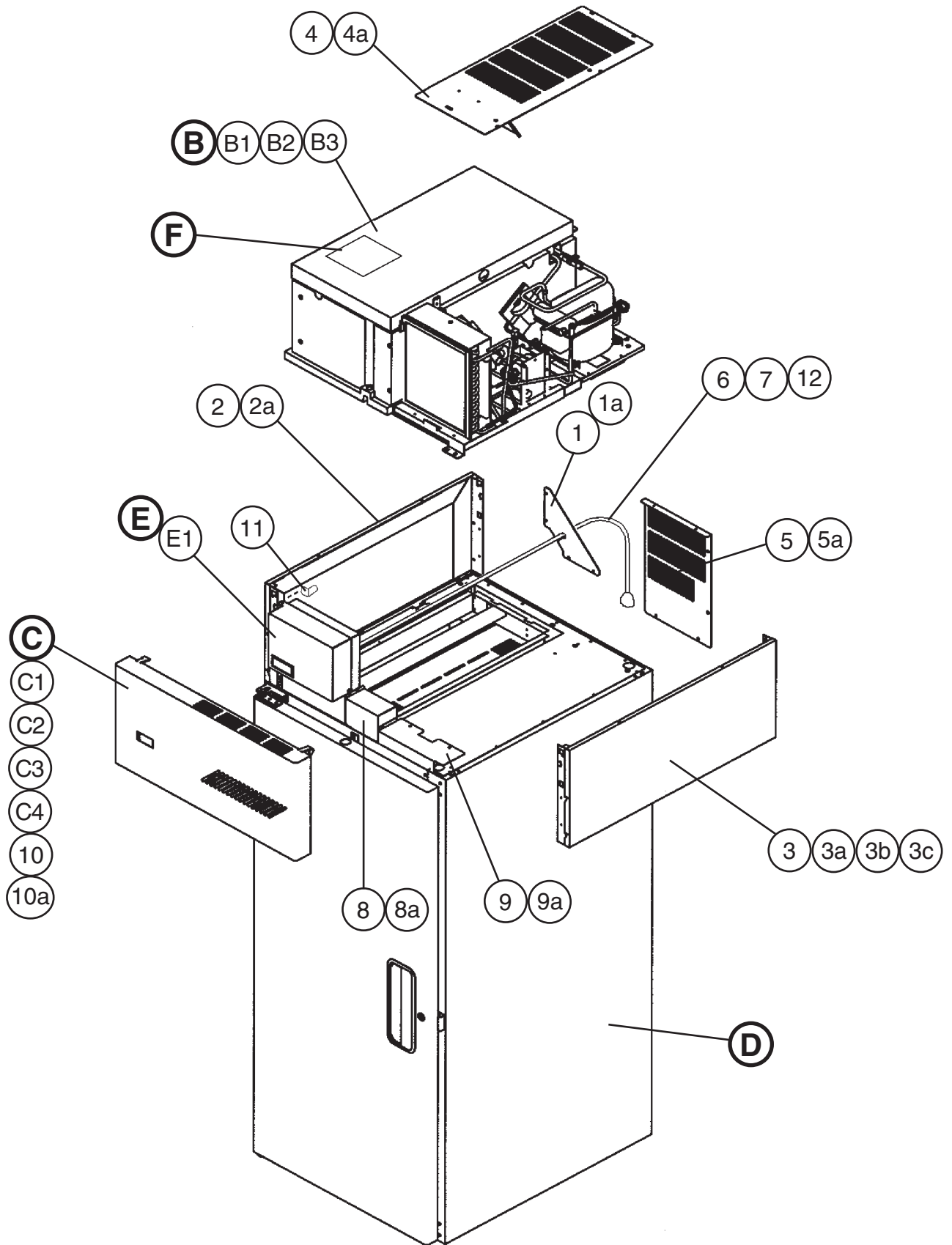

Title: A. Reach-In Model: RH1-AAC-W												
Index No.	Description	Material or Model Number	Part Number	Required Number								
				M-5 to Q-5	Q-6							
B	Refrigeration System	Refrigerator	1A0297A02	1	1							
B1	Bolt Assembly	8x45	437889-01	5	5							
B2	Truss Head Screw	5x25, SS	7C32-0525	2	2							
B3	Washer	5	7W22-0500	2	2							
C	Panel – Front Hinged Assembly	-	3A1670A01	1	1							
C1	Clevis Pin	-	8907-0102	2	2							
C2	Cotter Pin	-	8907-0103	2	2							
C3	Flat Washer	-	4A0655-03	2	2							
C4	Spacer – Hinge	-	4A2473-01	2	2							
D	Body – Final	-	1A0299A07	1	1							
E	Control Box Assembly	-	2A1842A01	1	1							
E1	T2 Screw	4x8, SS	7P32-0408	3	3							
F	Label Location	-	2A1042A12	1	1							
1	Gusset – Frame	GS	4A2845-01	1	-							
			4A3856-01		1							
1a	T2 Screw	4x8, SS	7P32-0408	4	4							
2	Frame – Side Top	GS	2A1803-01	2	2							
2a	Truss Head Screw	5x10, SS	7C32-0510	8	8							
3	Panel – Side, Top	SS	2A1800-21	2	2							
3a	Truss Head Screw	5x10, SS	7C32-0510	2	2							
3b	Taper Collar	SS	4H0171-01	2	2							
3c	Screw Countersunk	5x20, SS	7C42-0520	2	2							
4	UL – Cover Assembly Top	-	2A2757G02	1	1							
4a	T2 Screw	4x8, SS	7P32-0408	5	5							
5	Cover – UL, Rear	GS	2A2752-01	1	1							
5a	T2 Screw	4x8, SS	7P32-0408	4	4							
6	Power Cord	-	4A0520-01	1	1							
7	Wire Clamp	-	4A0809-02	1	1							
8	Cover – Connector Wire	GS	3A1678-01	1	1							
8a	T2 Screw	4x8, SS	7P32-0408	2	2							
9	Cover – Wire	GS	3A1679-01	1	1							
9a	T2 Screw	4x8, SS	7P32-0408	3	3							
10	Bracket – Hinge	GS	4A2306-01	2	2							
10a	T2 Screw	4x8, SS	7P32-0408	3	3							
11	Bracket – Control Box	-	4A2467-01	1	1							
12	Bushing	-	420470-01	1	1							

B. Refrigeration System

RH1-AAC-W

M-5, N-5, N-6, P-5, P-6, P-7, Q-5, Q-6

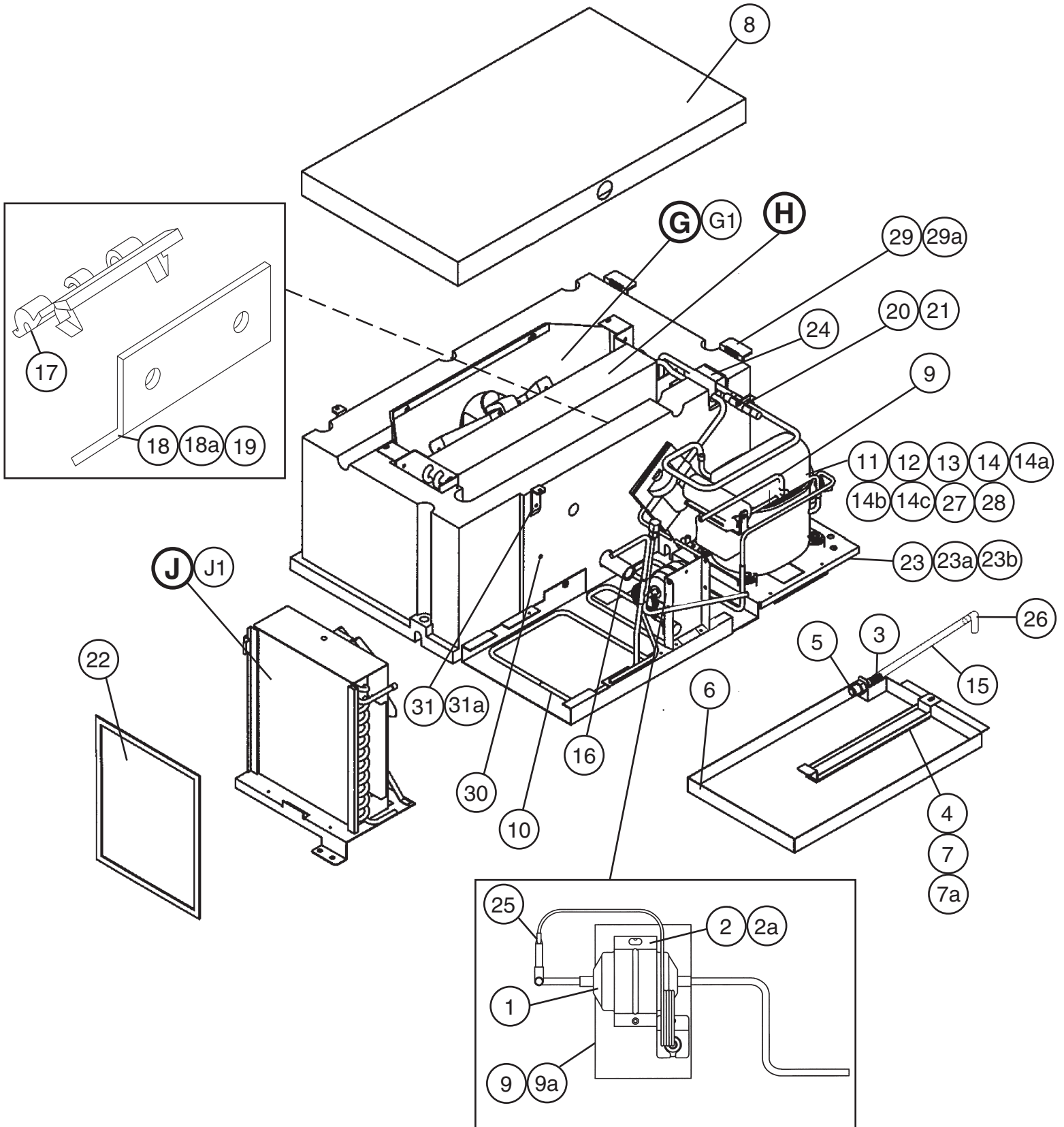

Title: B. Refrigeration System Model: RH1-AAC-W											
Index No.	Description	Material or Model Number	Part Number	Required Number							
				M-5 to Q-6							
G	Fan – Evaporator Assembly	-	2A0980A01	1							
G1	Truss Head Screw	4x12, SS	7C32-0412	4							
H	Evaporator Assembly	-	2A1263A02	1							
J	Condenser Assembly	-	3A2609A01	1							
J1	T2 Screw	4x8, SS	7P32-0408	2							
1	Drier	-	4A0924-01	1							
2	Mount – Drier	-	4A1480-01	1							
2a	T2 Screw	4x8, SS	7P32-0408	2							
3	Fitting – Drain Overflow		4A2182-01	1							
4	Gasket – Condensate Coil		4A0455-03	1							
5	Rubber Gasket		413854-03	1							
6	Pan – Evaporator Drain		2A2760-01	1							
7	Strap – Condensate Coil	GS	3A0232-03	1							
7a	Truss Head Screw	5x12, SS	7C32-0512	1							
8	Cover – Evaporator Case	-	2A2726G01	1							
9	Bracket – Drier	-	4A0806-01	1							
9a	T2 Screw	4x8, SS	7P32-0408	2							
10	Coil – Condensate		3A1644-01	1							
11	Protector		4A1875-02	1							
12	Compressor	-	2A1260-01	1							
13	Grommet – Compressor Mount	-	4A1305-01	4							
14	Sleeve – Grommet	-	4A0449-01	4							
14a	Hex Bolt	8x45	7B01-0845	4							
14b	Flat Washer	8	7W21-0800	4							
14c	Split Lock Washer	8	7L21-0800	4							
15	Vinyl Hose	L=300	7730I3812	1							
16	Pipe – Evaporator Drain	-	4A0831-01	1							
17	Thermistor Bracket (A)	-	433920-01	1							
18	Thermistor Bracket (B)	-	433964-01	1							
18a	Truss Head Screw	4x16, SS	7C32-0416	2							
19	Thermistor – Cabinet	Thermistor is to be replaced using kit HS-3540 . Apply to all aux. codes.									
20	Holder – Expansion Valve	-	3A0107-01	1							
21	Hose Clamp	-	443461-01	1							
22	Filter – Condenser	-	3A0277-01	1							
23	Compressor Base	GS	2A2756G01	1							
23a	Truss Head Screw	4x16, SS	7C32-0416	2							
23b	Truss Head Screw	5x10, SS	7C32-0510	1							
24	Seal – Evaporator Tubing	-	4A0642-01	2							
25	Switch – Pressure	-	4A2516-02	1							

Title: B. Refrigeration System Model: RH1-AAC-W												
Index No.	Description	Material or Model Number	Part Number	Required Number								
				M-5 to Q-6								
26	Elbow – Tubing	-	4A0711-01	1								
27	Start Relay	501-96175	Supplied with compressor	1								
28	Start Capacitor	243-292 MFD110		1								
29	Latch – Holder	-	4A2993-01	2								
29a	Truss Head Screw	4x16, SS	7C32-0416	4								
30	Wire Clamp	-	4A0809-01	1								
31	Latch – Case	-	4A2992-01	2								
31a	Truss Head Screw	4x16, SS	7C32-0416	2								

C. Panel-Front Hinged Assembly

RH1-AAC-W

M-5, N-5, N-6, P-5, P-6, P-7, Q-5, Q-6

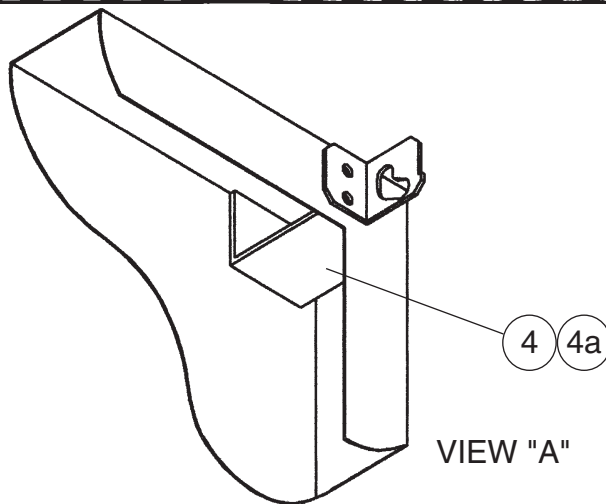
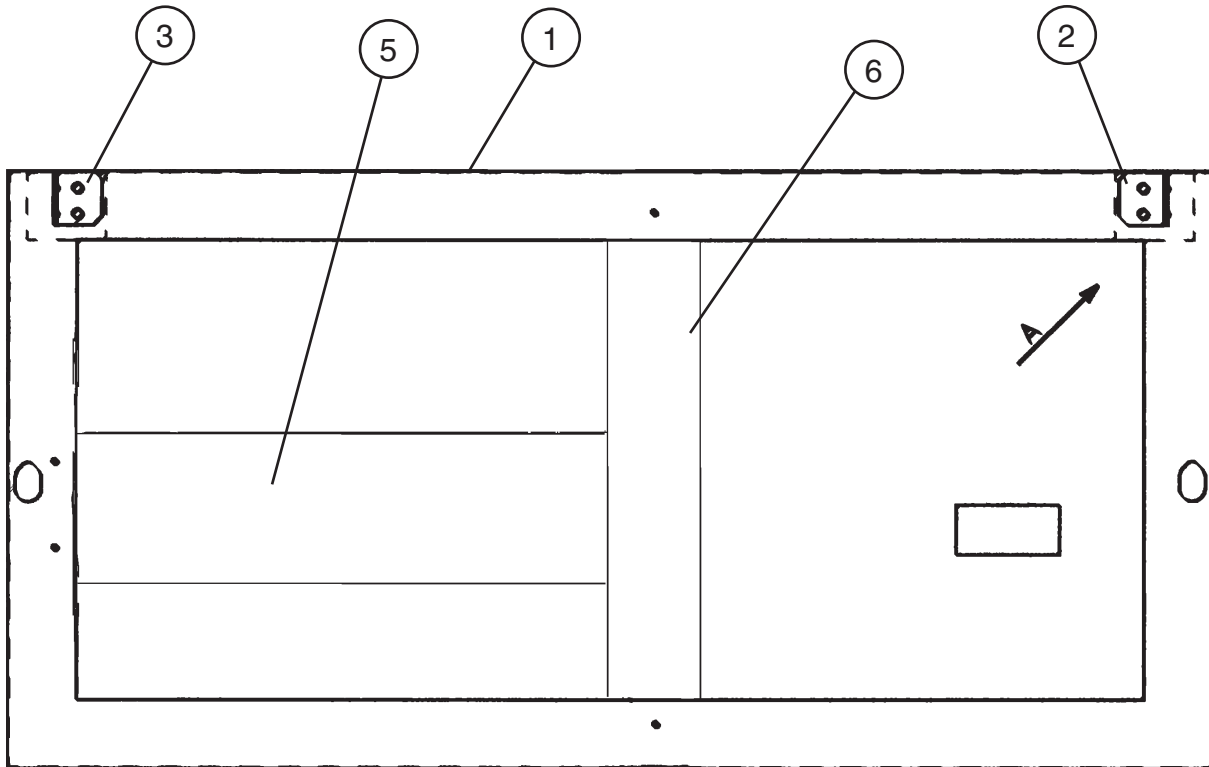

Title: C. Panel-Front Hinged Assembly		Model: RH1-AAC-W		Required Number								
Index No.	Description	Material or Model Number	Part Number	M-5 to Q-6								
					1	Panel – Front Hinged	SS	2A1799-01	1			
2	Hinge – Front Panel (L)	GS	4A2153-01	1								
3	Hinge – Front Panel (R)	GS	4A2154-01	1								
4	Channel – Hinge	GS	4A2170-01	2								
4a	Truss Head Screw	5x8, SS	7C32-0508	4								
5	Blind	GS	3A1763-01	1								
6	Support – Blind	GS	4A2267-01	1								

D. Body-Final
RH1-AAC-W

M-5, N-5, N-6, P-5, P-6, P-7, Q-5, Q-6

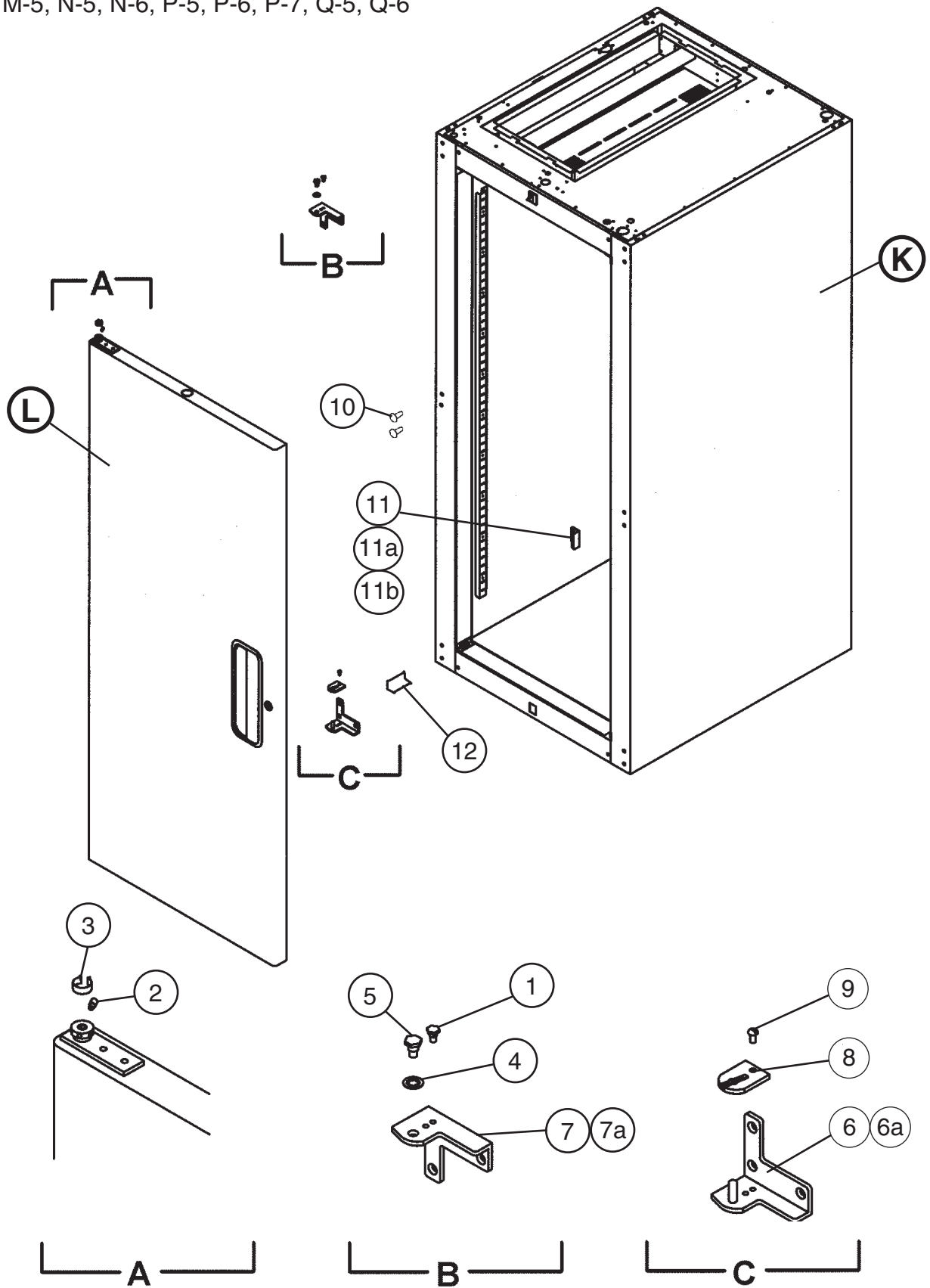

Title: **D. Body-Final** Model: **RH1-AAC-W**

Index No.	Description	Material or Model Number	Part Number	Required Number											
				M-5 to Q-6											
K	Body – Prefinal	-	1A0298A03	1											
L	Door – Left	-	1A0318A04	1											
1	Hinge – Stop Pin	PS	4A2180-01	1											
2	Hinge – Tension Screw	PS	4A0446-01	1											
3	Hinge – Bushing Cover	SS	4A0445-01	1											
4	Hinge – Lock Washer	PS	4A0553-01	1											
5	Hinge – Pivot Pin (Top)	PS	4A2179-01	1											
6	Bracket – Door Hinge (LL)	PS	3A1627-01	1											
6a	Countersunk Screw	5x20, SS	7C42-0520	3											
7	Bracket – Door Hinge (UL)	PS	3A1581-01	1											
7a	Countersunk Screw	5x20, SS	7C42-0520	3											
8	Hinge – Stop Plate (L)	PS	4A0441-02	1											
9	Screw – Stop Plate	PS	4A0483-01	1											
10	Canoe Clip	-	4A0629-01	2											
11	Plate – Strike (Side)	SS	4A0470-01	1											
11a	T2 Screw	4x8, SS	7P32-0408	2											
11b	Truss Head Screw	5x10, SS	7C32-0510	6											
12	Cover – Corner	ABS	3A1751-01	4											

E. Control Box Assembly RH1-AAC-W

M-5, N-5, N-6, P-5, P-6, P-7, Q-5, Q-6

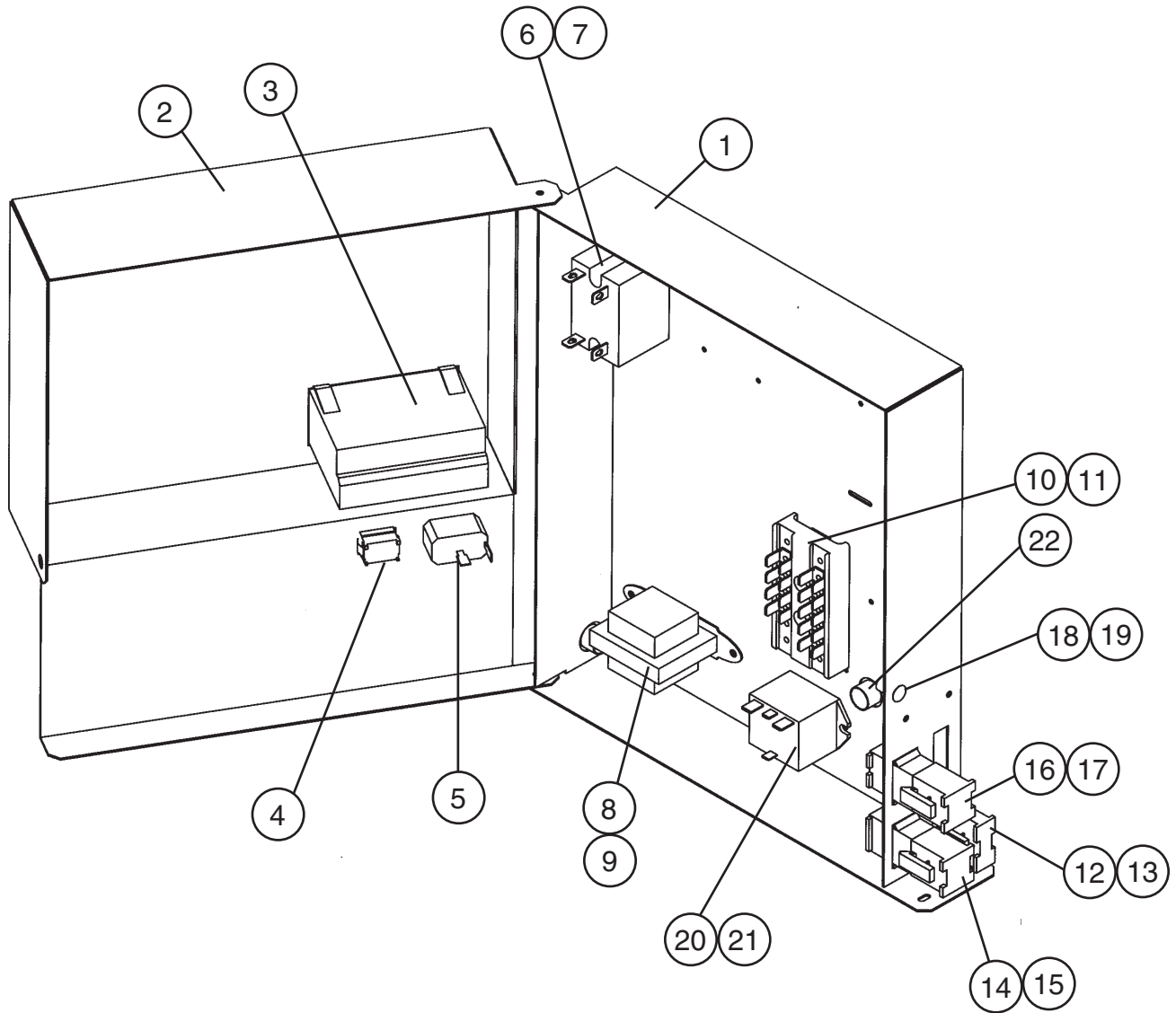

Title: E. Control Box Assembly Model: RH1-AAC-W												
Index No.	Description	Material or Model Number	Part Number	Required Number								
				M-5 to P-5	P-6 to Q-5	Q-6						
1	Base – Control Box	GS	2A1887-01	1	1	1						
2	Cover – Control Box	GS	2A1833-01	1	1	1						
3	Board – Control Display	Use latest for all aux. codes	4A2203-01	1	-							
	Controller		3A3372-01		1	-						
			3A3656-01				1					
4	Switch – Rocker	1801.110	4A0418-01	1	1	1						
5	Switch – Toggle	780K21	4A0424-01	1	1	1						
6	Relay – Compressor	HE1aN-AC120V	4A1307-01	1	1	1						
7	Tapping Screw	3x8	431415-01	1	1	1						
8	Transformer	BE110805GAA	4A2202-01	1	1	1						
9	Tapping Screw	3x8	431415-01	2	2	2						
10	Terminal Block	ESB1-6-8	4A2619-01	1	1	1						
11	Tapping Screw	3x8	431415-01	2	2	2						
12	Plug Housing	03-12-2035	4A0425-01	1	1	1						
13	Receptacle Housing	03-12-1036	4A0426-01	1	1	1						
14	Plug Housing (6 Pin)	3191-06P	412832-03	1	1	1						
15	Receptacle Housing (6 Pin)	3191-06R1	412831-03	1	1	1						
16	Plug Housing (6 Pin)	3191-06P	412832-12	1	1	1						
17	Receptacle Housing (6 Pin)	3191-06R1	412831-12	1	1	1						
18	Insert – Threaded	M5	4A0407-01	1	1	1						
19	Truss Head Screw	4x8, SS	7C32-0408	1	1	1						
20	Relay – Door Switch	JA1b-TM-AC12V	4A2268-01	1	1	1						
21	Tapping Screw	3x8	431415-01	2	2	2						
22	Bushing	SB-625-8	420470-01	1	1	1						

F. Label Location

RH1-AAC-W

M-5, N-5, N-6, P-5, P-6, P-7, Q-5, Q-6

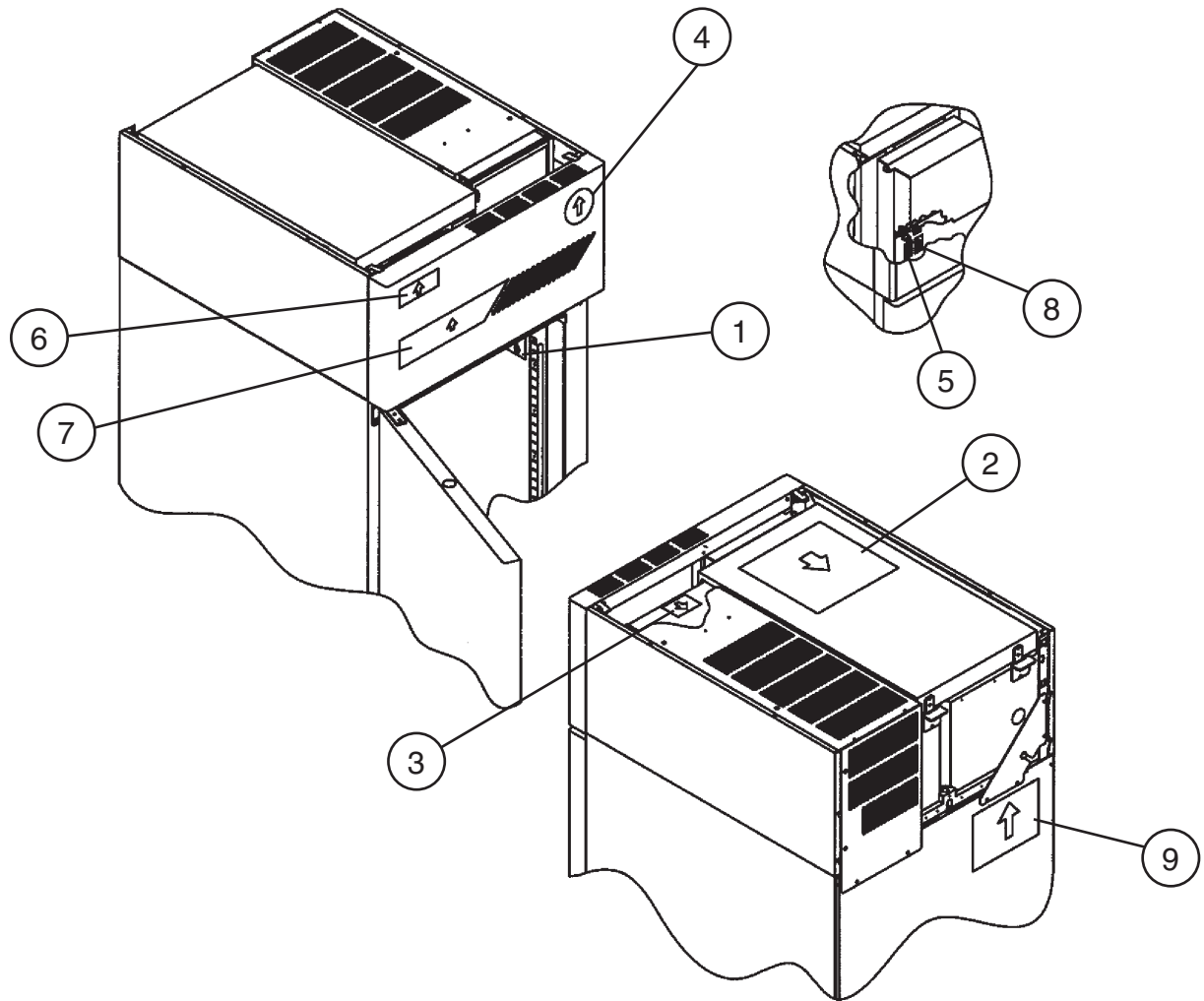

Title: F. Label Location Model: RH1-AAC-W														
Index No.	Description	Material or Model Number	Part Number	Required Number										
				M-5 to P-5	P-6 to Q-6									
1	Cover – Nameplate	-	4A3727-01		1									
2	Wiring Label	-	2A2767-01	1	1									
3	Label – R404A	-	4A0960-01	1	1									
4	Label – Penguin – HA (L)	-	4A0526-02	1	1									
5	Label – Power	-	4A2196-01	1	1									
6	Emblem – Hoshizaki	-	4A0560-01	1	1									
7	Label – Display	-	4A2198-01	1	1									
8	Label – Door Heater Switch	-	4A1039-01	1	1									
9	Caution Label	-	4A1931-01	1	1									

G. Fan-Evaporator Assembly RH1-AAC-W

M-5, N-5, N-6, P-5, P-6, P-7, Q-5, Q-6

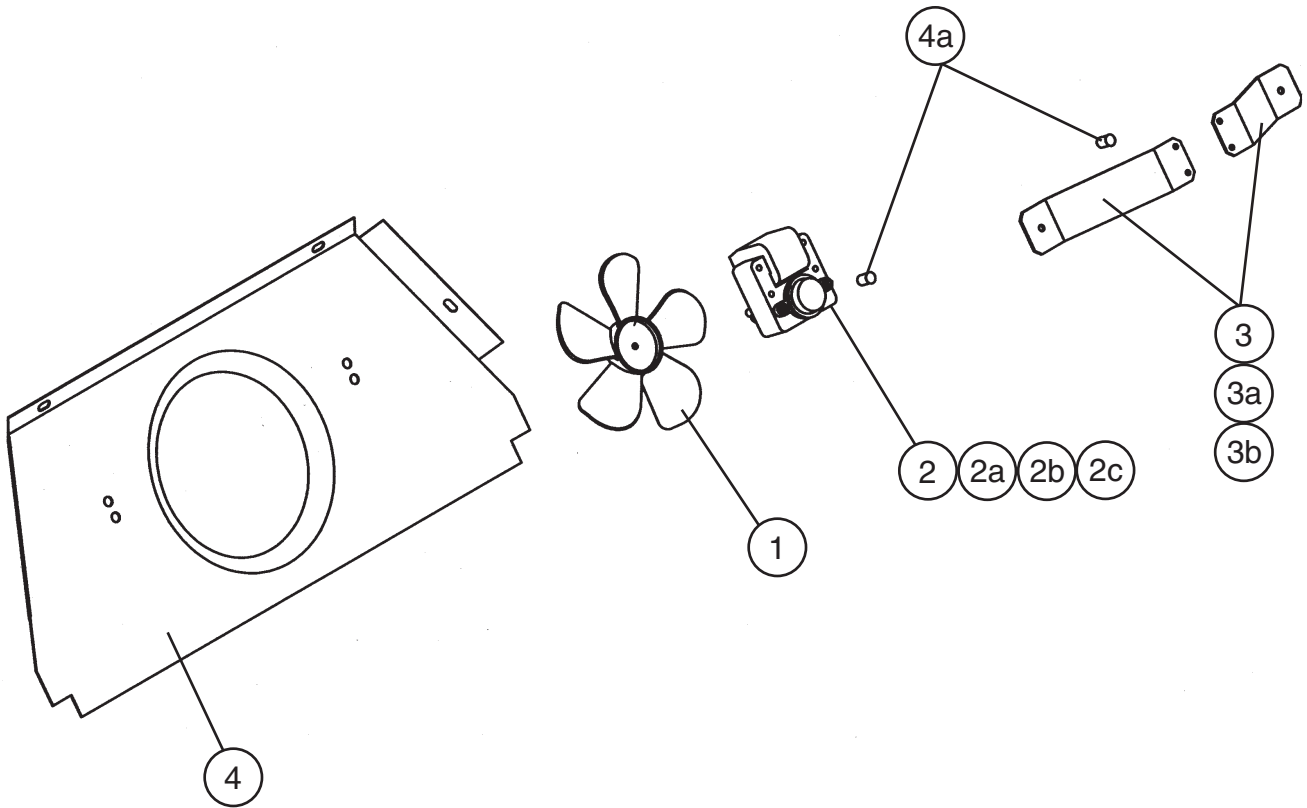

Title: G. Fan-Evaporator Assembly Model: RH1-AAC-W					Required Number								
Index No.	Description	Material or Model Number	Part Number	M-5 to Q-6									
1	Blade – Evap Fan	-	4A2378-01	1									
2	Motor – Fan Evap	-	4A2563-01	1									
2a	Truss Head Screw	4x40, SS	7C32-0440	4									
2b	Hex Nut	M4, SS	7N12-0400	4									
2c	Split Lock Washer	M4, SS	7L22-0400	4									
3	Bracket – Fan Motor	SS	3A2501-01	2									
3a	Truss Head Screw	5x12, SS	7C32-0512	2									
3b	Lock Washer	-	4A0459-01	2									
4	Shroud – Evap Fan	SS	2A0846-01	1									
4a	Insert – Threaded	M5	4A0407-01	2									

H. Evaporator Assembly RH1-AAC-W

M-5, N-5, N-6, P-5, P-6, P-7, Q-5, Q-6

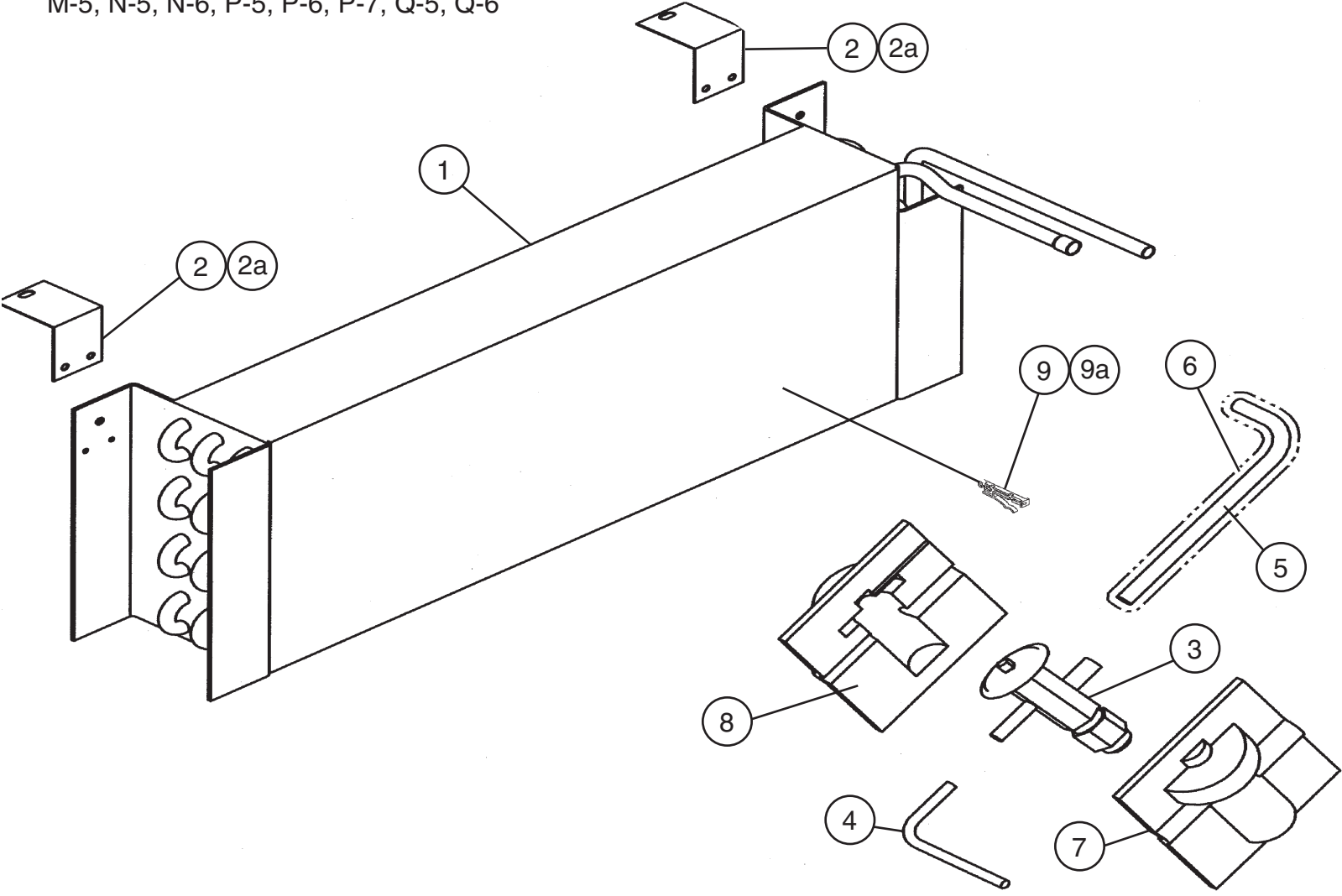

Title: H. Evaporator Assembly Model: RH1-AAC-W																		
Index No.	Description	Material or Model Number	Part Number	Required Number														
				M-5 to Q-6														
1	Evaporator	Heatcraft 03EZ0603K-8x19	2A1262-01	1														
2	Bracket – Evaporator	SS	4A2542-01	2														
2a	T2 Screw	4x8, SS	7P32-0408	4														
3	Expansion Valve	-	4A1594-01	1														
4	Tube – Liquid	-	4A1332-01	1														
5	Tube – Evaporator Inlet	-	4A1292-01	1														
6	Insulation Tubing	L=350	7762-0717	1														
7	Expansion Valve Cover (A)	-	3A0372-01	1														
8	Expansion Valve Cover (B)	-	3A0372-02	1														
9	Thermistor – Defrost	Thermistor is to be replaced using kit HS-3540 . Apply to all aux. codes.																
	Clip – Thermistor	-	4A3248G01	1														
9a	Nylon Tie	-	8911-0150	1														

J. Condenser Assembly RH1-AAC-W

M-5, N-5, N-6, P-5, P-6, P-7, Q-5, Q-6

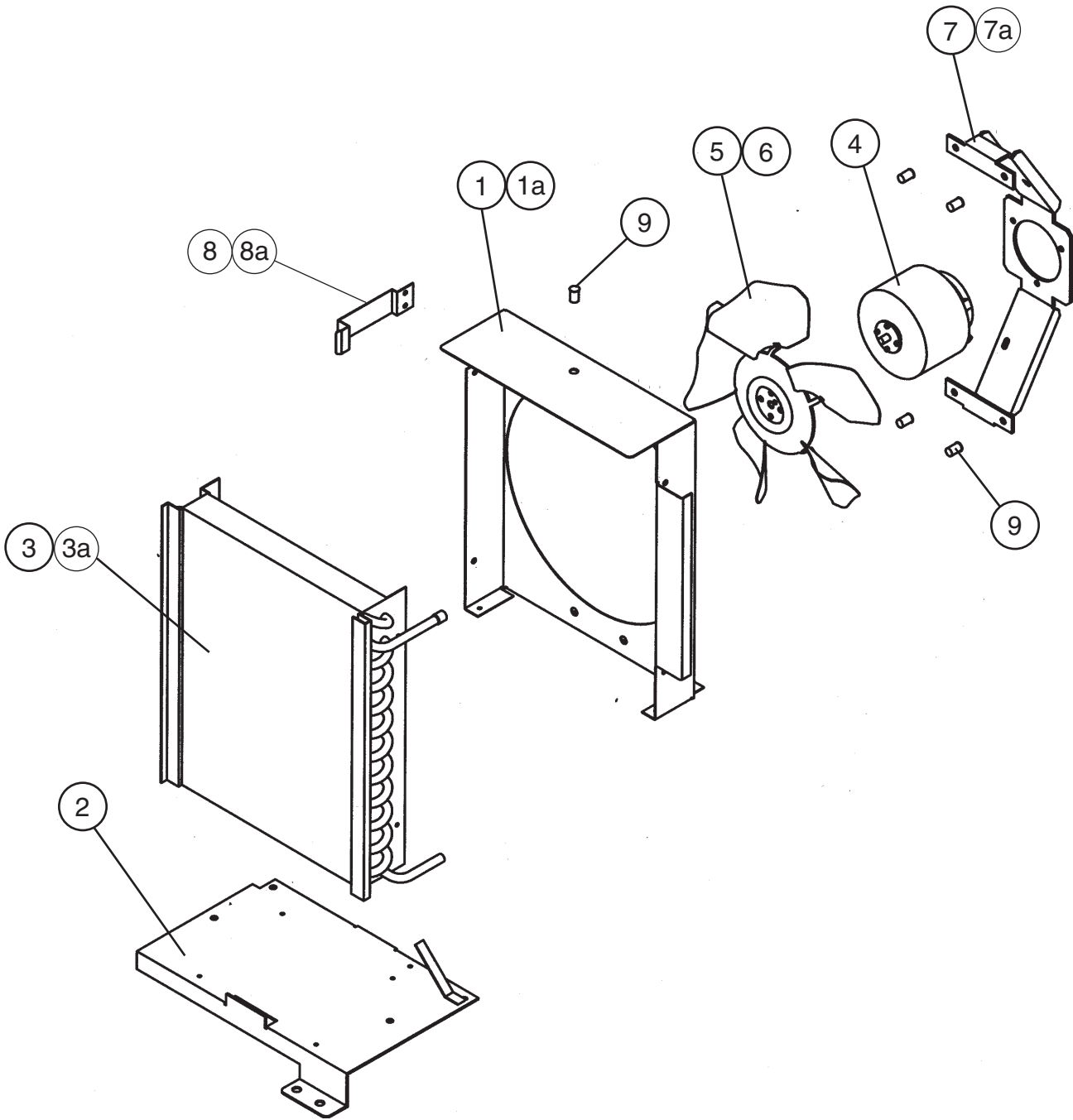

Title: J. Condenser Assembly Model: RH1-AAC-W												
Index No.	Description	Material or Model Number	Part Number	Required Number								
				M-5 to Q-6								
1	Shroud – Condenser	GS	2A2722-01	1								
1a	T2 Screw	4x8, SS	7P32-0408	4								
2	Base – Condenser	GS	2A2724G01	1								
3	Condenser	Heatcraft 2CZ1002N-12x9	2A0623-01	1								
3a	T2 Screw	4x8, SS	7P32-0408	4								
4	Motor – 16W	-	4A0815-01	1								
5	Blade – Cond Fan	Air Drive AD9CW30UBA	3A0436-01	1								
6	Hex Nut	PS	4A1345-01	1								
7	Bracket – Condenser Fan	GS	3A1564-01	1								
7a	Truss Head Screw	5x12, SS	7C32-0512	4								
8	Retainer – Filter	GS	4A0790-01	1								
8a	T2 Screw	4x8, SS	7P32-0408	2								
9	Insert – Threaded	M5	4A0407-01	5								

K. Body-Prefinal
RH1-AAC-W

M-5, N-5, N-6, P-5, P-6, P-7, Q-5, Q-6

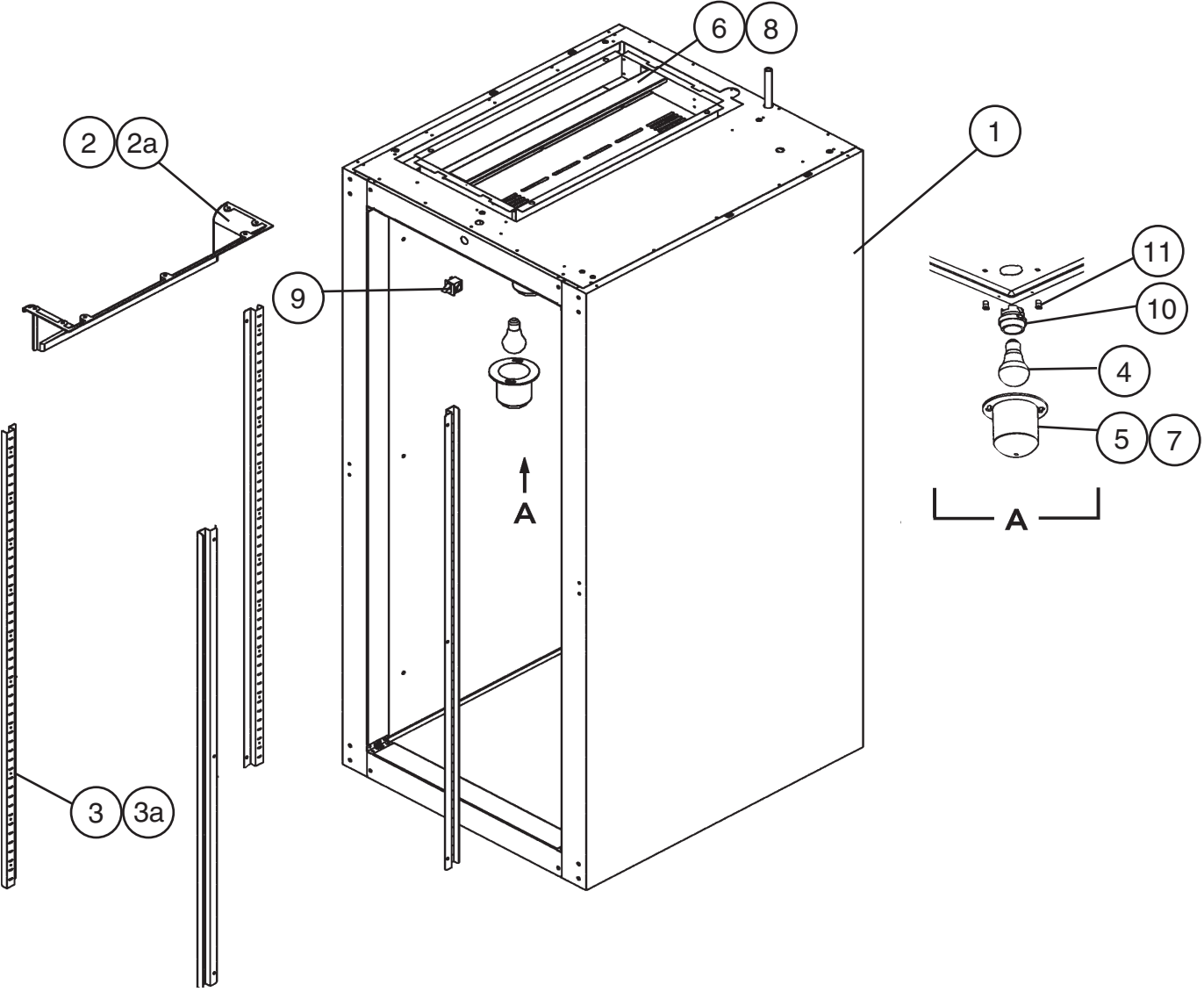

Title: K. Body-Prefinal Model: RH1-AAC-W												
Index No.	Description	Material or Model Number	Part Number	Required Number								
				M-5 to Q-6								
1	Cabinet – Prefoam	-	1A0173G03	1								
2	Distributor – Air Top Assembly	SS	2A0438G01	1								
2a	T2 Screw	4x8, SS	7P32-0408	7								
3	Pilaster	AL	3A0145-21	4								
3a	Truss Head Screw	5x10, SS	7C32-0510	12								
4	Bulb – Light	-	4A2420-01	1								
5	Shield – Light	Standard Keil 2778-1010-3000	4A0465-01	1								
6	Plate – ABS	ABS	4A0758-01	1								
7	Cheese Head Screw	5x12, SS	7C52-0512	2								
8	Divider – Air	-	2A0199-21	1								
9	Switch – Door	-	3A1826-01	1								
10	Lampholder	-	4A2862-01	1								
11	Insert – Threaded (Wide)	-	4A0839-01	2								

L. Door-Left
RH1-AAC-W

M-5, N-5, N-6, P-5, P-6, P-7, Q-5, Q-6

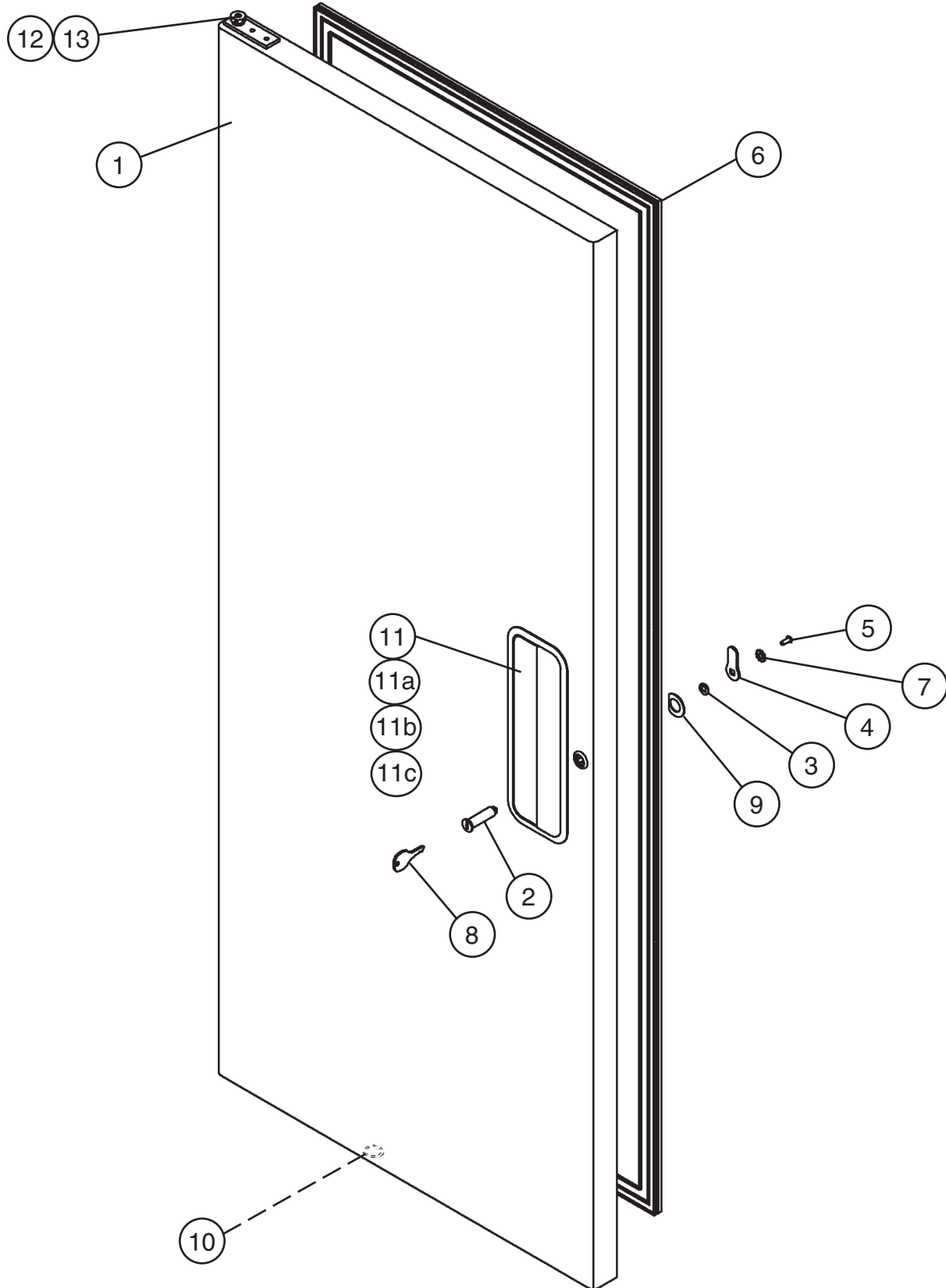

Title: L. Door-Left Model: RH1-AAC-W													
Index No.	Description	Material or Model Number	Part Number	Required Number									
				M-5 to Q-6									
1	Door – Prefoam (L)	-	1A0317G04	1									
2	Lock – Tumbler	M4-5813-001	4A0462-01	1									
3	Lock – Stop Washer	M5-8060-103	4A0458-01	1									
4	Cam – Door Lock	P.S	4A0228-01	1									
5	Lock – Screw	SS	4A0461-01	1									
6	Gasket – Door	Jarrow #P-2209244A GRAY	3A0273-01	1									
7	Lock Washer	SS	4A0459-01	1									
8	Lock – Key	M5-0680-111	4A0460-01	1									
9	Washer – Door Lock	SS	4A0670-01	1									
10	Locking Hole Plug	-	4A0586-06	1									
11	Handle Door	-	3A0252A01	1									
11a	Handle – Door (Base)	3A0252A01	1A0056-01	1									
11b	Machine Screw	3A0252A01 8-32 x 1/2	7C1110812	4									
11c	Flat Washer	3A0252A01 #10	7W21-1000	4									
12	Hinge – Spring	-	4A3312-02	1									
13	Hinge – Spring Cart	-	4A0438-02	1									

M. Literature & Packaging

RH1-AAC-W

M-5, N-5, N-6, P-5, P-6, P-7, Q-5, Q-6

Title: M. Literature & Packaging Model: RH1-AAC-W											
Index No.	Description	Material or Model Number	Part Number	Required Number							
				M-5 to P-6	P-7 to Q-6						
1	Instruction Manual	Paper	91A34010L	1	1						
Packaging (Available only for models currently in production)			1A0765A04	1	1						
1	Filler – Door		4A2977-01	2	2						
2	Pad – Corner		3A2598-01	4	4						
3	Post – Corner		3A2603-01	4	4						
4	Support – Corner		3A2596-01	4	4						
5	T2 Screw	4x8, SS	7P32-0408	4	4						
6	Bracket (A) – Overflow Pan		4A0878-01		1						
7	Bracket (B) – Overflow Pan		4A0879-01		1						
8	Pan – Overflow		4A2081-01	1	-						
			4A3419G01		1						
9	Stop – Door		4A1873-01	2	2						
10	Flat Washer		7W21I5800	4	4						
11	Hex Head Bolt		7B01 I5825	4	4						
12	Pallet		3A1814-01	1	1						
13	Protector – Front		3A2595-01	1	1						
14	Caster Shim	-	HS-3590		1						
15	Caster Kit	-	HS-3546		1						
16	Cap – Folding	-	3A2604-01		1						
17	Shelf (3 pack)	-	HS-3508	1	1						