

Hoshizaki America, Inc.

Condensing Unit Serenity Series

Model
SRK-13H



“A Superior Degree
of Reliability”

www.hoshizaki.com

PARTS LIST



Number: 71261
Issued: 1-26-2007

CONTENTS

Auxiliary Codes.....	3
Note About Ordering Parts	3
Material Abbreviations	4
A. Condensing Unit.....	5
B. Refrigeration Circuit.....	7
C. Control Box Assembly	10
D. Label Location	11
E. Accessories	12

Auxiliary Codes

SRK-13H R-0 September 2006
 S-0 February 2007

Auxiliary Code Breakdown

K-0

- └─ Designates the year. "K" indicates the year 2000. Years progress or regress in alphabetical order. "J" is 1999, "L" is 2001, "M" is 2002, and so on. The letters "I" and "O" were skipped.
- └─ Designates significant part changes within the same year for this model. Base is 0 and this number advances for each change.

Example: P-1

- └─ "P" indicates 2004.
- └─ "1" indicates the first significant part change for 2004.

Note About Ordering Parts

Most assemblies cannot be ordered as complete units; parts in the assemblies generally must be ordered separately.

Material Abbreviations

ALUMINUM

AL = Aluminum

COPPER

CU = Copper

PLASTIC

ABS = Acrylonitrile -butadiene - styrene
AC = Polyacetal
EVA = Ethylene vinyl acetate
PA = Polyamide = Nylon
PC = Polycarbonate
PE = Polyethylene
PES = Polyester
PETP = Polyethylene terephthalate = Tetlon
PP = Polypropylene
PS = Polystyrene
PTFE = Polytetrafluoroethylene = Teflon
PUR = Polyurethane
PVC = Polyvinyl chloride

RUBBER

VN = Vinyl Nitrile
EPDM = EP rubber
NBR = Nitrile butadiene rubber
NR = Natural rubber
NP = Neoprene
SI.R = Silicone rubber
SY.R = Synthetic rubber
EPH = Epichlorohydrin

STEEL

GS = Galvanized steel
SS = Stainless steel
PS = Plated steel
PAS = Primed steel

A. Condensing Unit
SRK-13H
 R-0, S-0

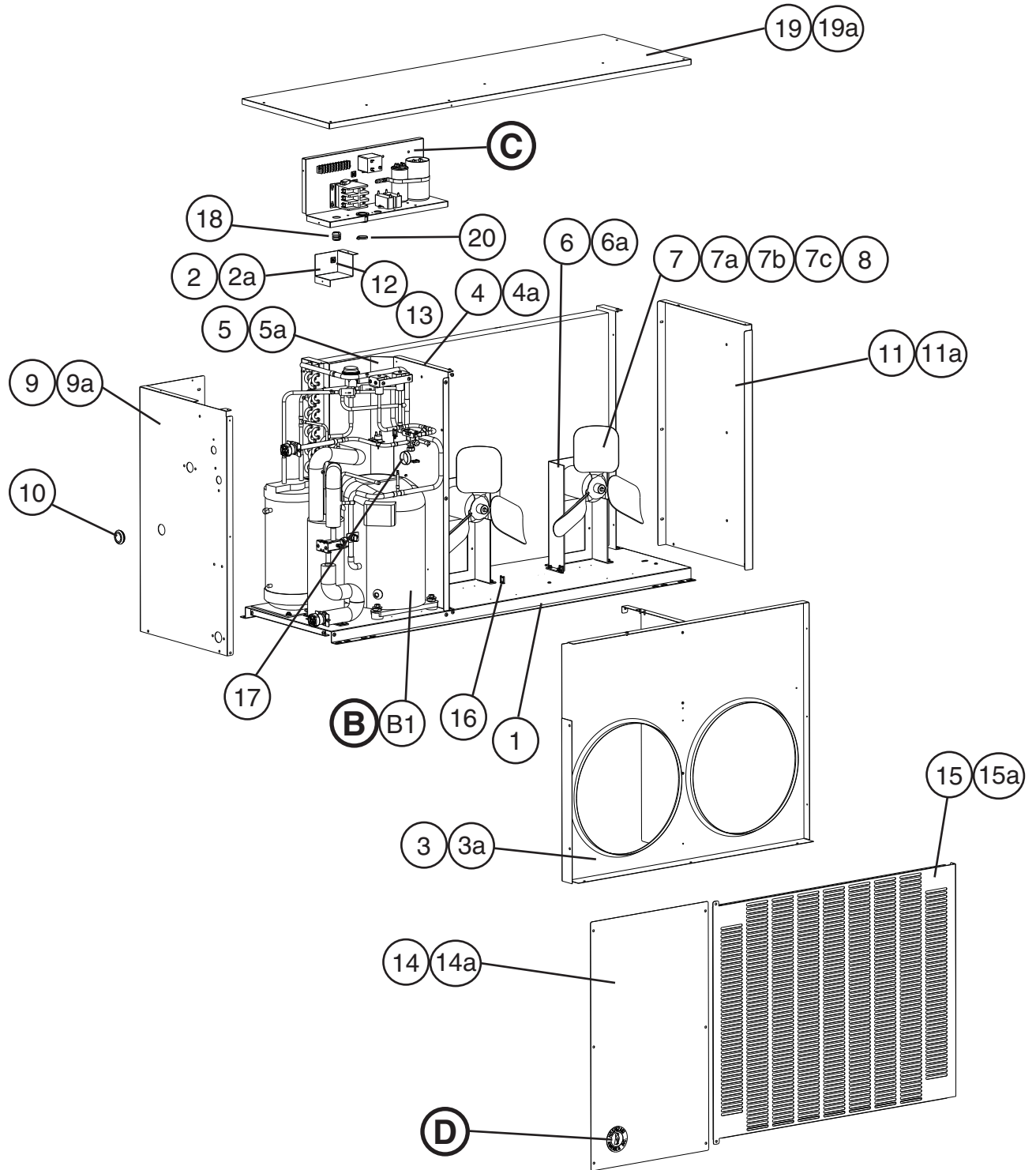

Title: **A. Condensing Unit** Model: **SRK-13H**

Index No.	Description	Material or Model Number	Part Number	Required Number									
				R-0	S-0								
B	Refrigeration Circuit	-	1A0979A01	1									
B1	T2 Screw	4x8 SS	7P32-0408	10									
C	Control Box Assembly	-	3A3285A01	1									
D	Label Location	-	2A3255A01	1									
1	Base	GS	3A3284G01	1									
2	Junction Box	GS	3A3286-01	1									
2a	T2 Screw	4x8 SS	7P32-0408	2									
3	Shroud	-	3A3287G01	1									
3a	T2 Screw	4x8 SS	7P32-0408	3									
4	Shroud (C)	GS	2A3239-01	1									
4a	T2 Screw	4x8 SS	7P32-0408	6									
5	Shroud (D)	GS	3A3288-01	1									
5a	T2 Screw	4x8 SS	7P32-0408	5									
6	Fan Motor Bracket	GS	3A3289-01	2									
6a	Hex Bolt Assembly (LF)	5x12 SS	7B0230512	8									
7	Fan Motor	63 WATT	4A3201-01	2									
7a	Split Lock Washer	NO.8-32 SS	7L2210832	8									
7b	Flat Washer	8-32 SS	7W2210832	8									
7c	Hex Nut	NO.8-32 UNC SS	7N0210832	8									
8	Fan Blade	CCW	4A3614-01	2									
9	Side Panel (L) - Rear	GS	3A3290-01	1									
9a	T2 Screw	4x8 SS	7P32-0408	7									
10	Grommet	-	410666-09	1									
11	Side Panel (R)	GS	3A3291-01	1									
11a	T2 Screw	4x8 SS	7P32-0408	8									
12	Square Washer	BRASS	433537-02	1									
13	Screw - Grounding	-	433304-02	1									
14	Front Panel	GS	3A3293-01	1									
14a	T2 Screw	4x8 SS	7P32-0408	6									
15	Louver Panel	GS	2A3241-01	1									
15a	T2 Screw	4x8 SS	7P32-0408	4									
16	Wire Saddle	VWS4274-C	4A0338-03	12									
17	Bushing	SB-1500-21	420470-06	1									
18	Bushing	SR-34-2	420472-05	1									
19	Top Panel	GS	2A3242-01	1									
19a	T2 Screw	4x8 SS	7P32-0408	10									
20	Cable Tie	-	8911-0200	1									

B. Refrigeration Circuit
SRK-13H
 R-0, S-0

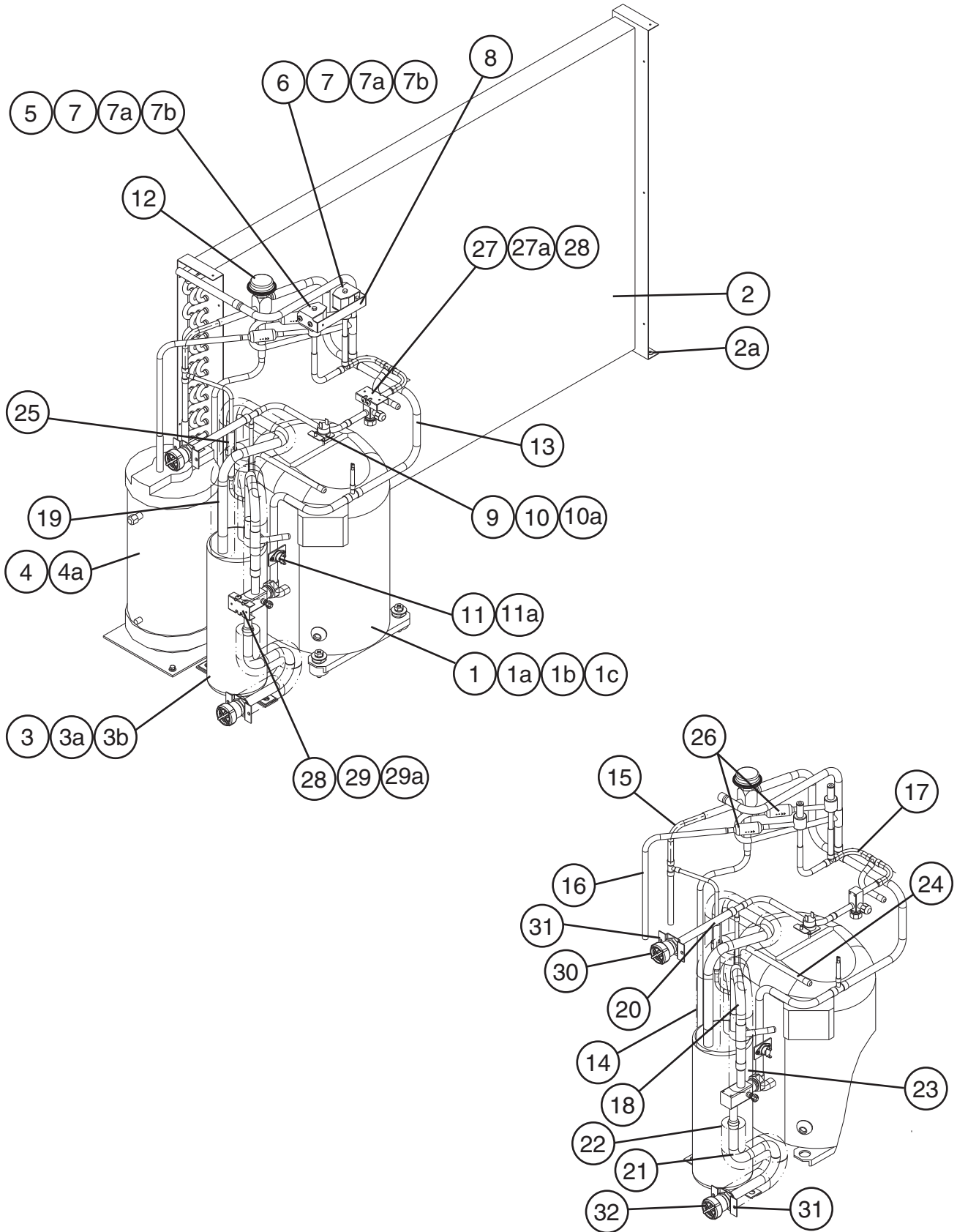

Title: **B. Refrigeration Circuit** Model: **SRK-13H**

Index No.	Description	Material or Model Number	Part Number	Required Number									
				R-0	S-0								
1	Compressor	CS18K6E-PFV-279	4A2334-02	1									
1a	Grommet	027-0167-00	434922-01	4									
1b	Spacer	028-0188-02	434921-01	4									
1c	Bolt Assembly	8x45	437889-01	4									
2	Condenser	-	1A0980-01	1									
2a	T2 Screw	4x8 SS	7P32-0408	2									
3	Suction Accumulator	-	3A4276-01	1									
3a	Spacer - Accumulator	-	4A3599-01	1									
3b	Hex Bolt Assembly (LF)	5x12 SS	7B0230512	2									
4	Receiver Tank	-	438209-01	1									
4a	Hex Bolt Assy (LF)	5x10 SS	7B0230510	2									
5	Valve Body - Line	-	4A3276-01	1									
6	Valve Body - Hot Gas	-	4A3978-01	1									
7	Coil - Valve	-	4A3277-01	2									
7a	Bolt	-	4A3277F01	2									
7b	Truss Head Screw	4x8 SS	7C32-0408	4									
8	Valve Bracket	GS; See A. Condensing Unit, item B1 for mounting screws	4A3587-01	1									
9	Pressure Switch	-	433441-07	1									
10	Pressure Switch Bracket	GS	434938-01	1									
10a	T2 Screw	4x8 SS	7P32-0408	1									
11	Thermostat	CS-12A 130C	440664-01	1									
11a	Pan Head Screw	3x8 SS	7C12-0308	2									
12	C.P. Regulator (Headmaster)	-	4A0229-03	1									
13	Copper Tube (A)	-	2A3243G01	1									
14	Copper Tube (B)	-	4A3588-01	1									
15	Copper Tube (C)	-	3A3294G01	1									
16	Copper Tube (D)	-	4A3589-01	1									
17	Copper Tube (F)	-	3A3295G01	1									
18	Copper Tube (G)	-	3A3296G01	1									
19	Copper Tube (H)	-	3A3297-01	1									
20	Copper Tube (J)	-	3A3715G01	1									
21	Copper Tube (K)	-	4A3598-01	1									
22	Insulation Tubing	7/8x3/8; L=380	7762-2040	1									
23	Insulation Tubing	5/8x1/4; L=630	7762-1630	1									
24	Copper Tube (A)	-	4A3610-01	1									
25	Check Valve	SKC 30564	4A1373-01	1									
26	Strainer	5/16	441569-02	2									
27	Shutoff Valve (access)	-	4A3491-01	1									
27a	T2 Screw	4x8 SS	7P32-0408	2									

Title: B. Refrigeration Circuit Model: SRK-13H												
Index No.	Description	Material or Model Number	Part Number	Required Number								
				R-0	S-0							
28	Bracket - Shutoff Valve	GS; See A. Condensing Unit, item B1 for mounting screws	4A3898-01	2								
29	Shutoff Valve (access)	-	4A3490-01	1								
29a	T2 Screw	4x8 SS	7P32-0408	2								
30	Coupling (Male)	5782-8-10 (INCL F01)	434072-01	1								
31	Tube Holder - L	GS; See A. Condensing Unit, item B1 for mounting screws	438245-02	2								
32	Coupling (Male)	5782-10-11	4A3826-01	1								

C. Control Box Assembly
SRK-13H
R-0, S-0

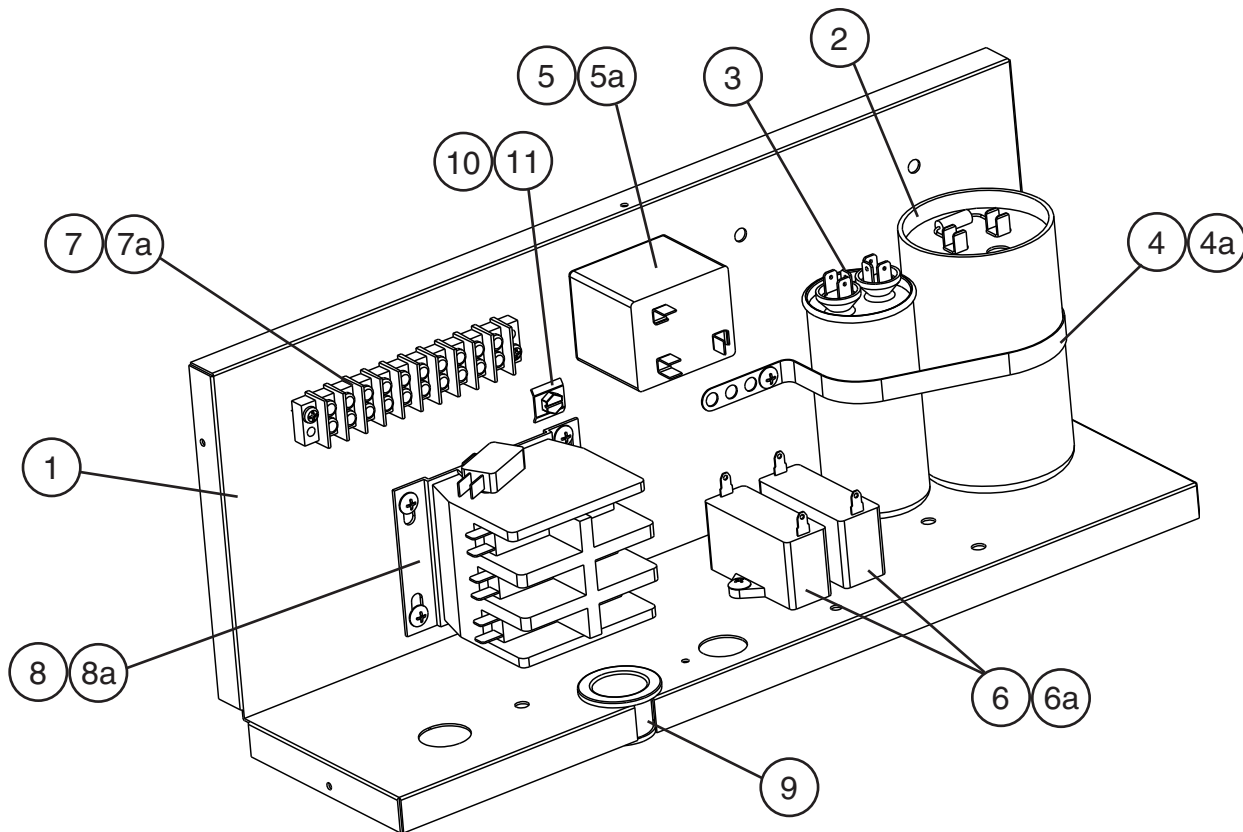

Title: C. Control Box Assembly Model: SRK-13H					Required Number								
Index No.	Description	Material or Model Number	Part Number	R-0 S-0									
1	Control Box	GS	2A3244-01	1									
2	Capacitor - Start	145-175MFD/ 250V	3A0076-01	1									
3	Capacitor - Run	35MFD/370V	3A2005-05	1									
4	Strap	GS	4A2262-05	1									
4a	T2 Screw	4x8 SS	7P32-0408	1									
5	Starter (Relay)	3ARR3CT10S5	4A1107-09	1									
5a	T2 Screw	4x8 SS	7P32-0408	1									
6	Capacitor	10MFD/250V	443192-01	2									
6a	T2 Screw	4x10 SS	7P32-0410	2									
7	Terminal Block	-	4A4201-01	1									
7a	Pan Head Screw	4x12 SS	7C12-0412	2									
8	Magnetic Contactor	-	4A0794-01	1									
8a	T2 Screw	4x8 SS	7P32-0408	4									
9	Grommet	-	4H2568-01	1									
10	Square Washer	BRASS	433537-02	1									
11	Screw - Grounding	-	433304-02	1									

D. Label Location
SRK-13H
 R-0, S-0

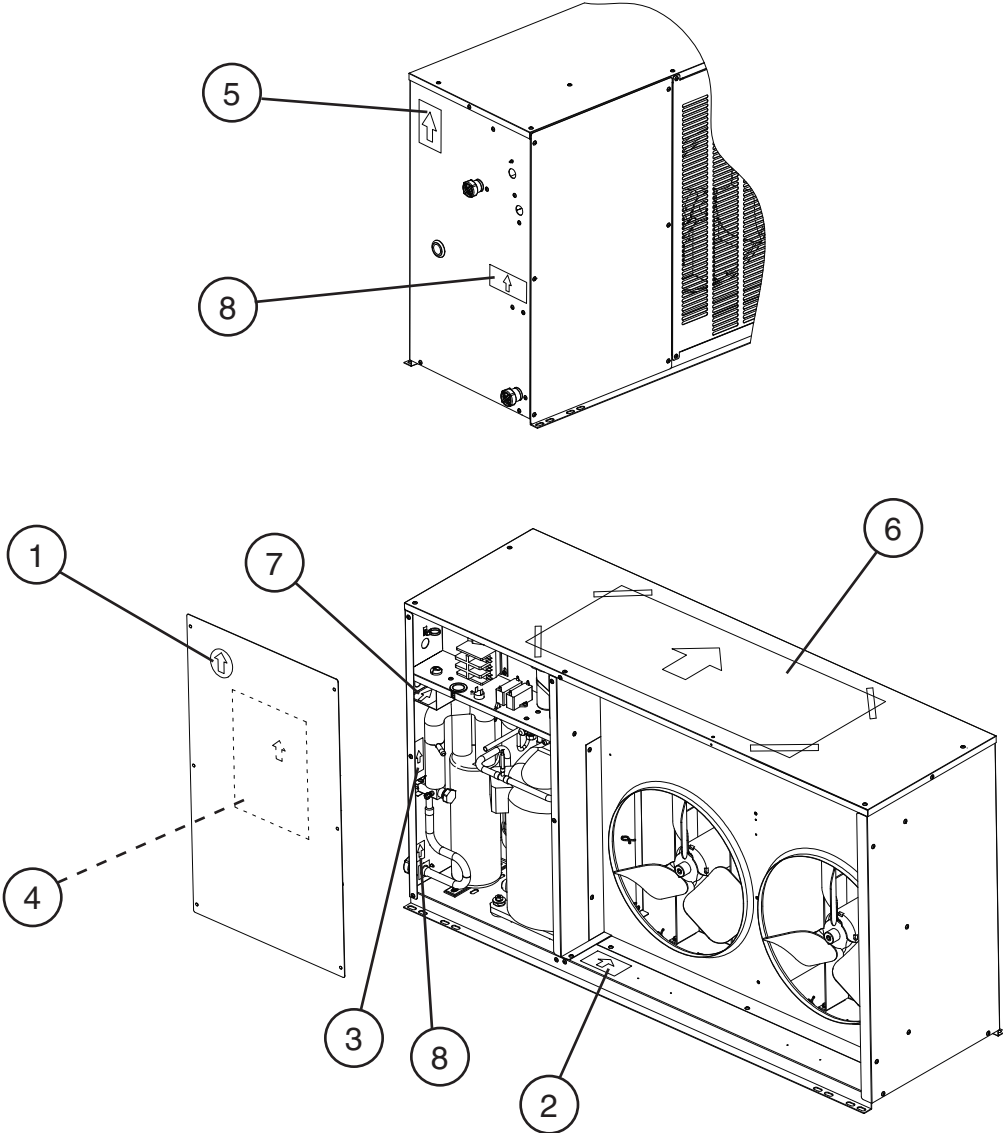

Title: D. Label Location Model: SRK-13H											
Index No.	Description	Material or Model Number	Part Number	Required Number							
				R-0	S-0						
1	Label - Penguin - HA (R)	-	4A0526-01	1							
2	Caution Label (F)	-	439146-01	1							
3	Caution Label (H)	-	439148-01	1							
4	Wiring Label	-	2A3297-01	1							
5	Nameplate	-	2A3301-01	1							
6	Instruction Sheet	-	2A3299-01	1							
7	Tag Warning: Electrical Connection	-	428430-01	1							
8	Label - R404A	-	4A0960-01	2							

E. Accessories
SRK-13H
 R-0, S-0

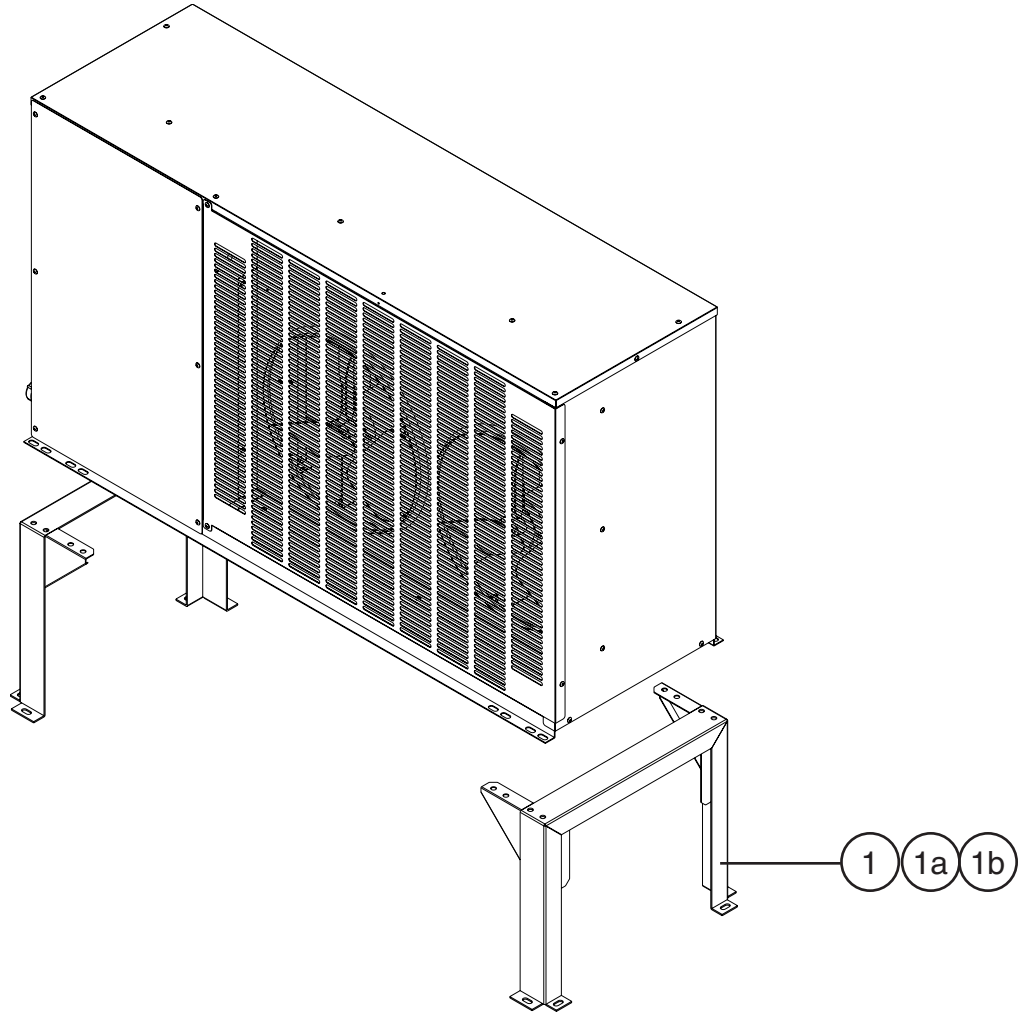

Title: E. Accessories Model: SRK-13H				Required Number									
Index No.	Description	Material or Model Number	Part Number	R-0									
				S-0									
1	Leg	-	3A3716G01	2									
1a	Hex Head Bolt w/ Washer	8x16 SS	7B0230816	16									
1b	Hex Nut	M8 SS	7N12-0800	16									