



8 Series Controlled Temperature Heated Holding Cabinets

USER MANUAL

This manual covers cabinets with electrical ratings of: 120V 2000W, 120V 1440W & 220-240V 1681-2000W.

When ordering electrical parts, always confirm the rating listed on rear cabinet data plate. Differences on voltage, amps or wattage are listed with **bold text** in replacement part descriptions.

**Metro Heated Cabinets are for
Hot Food Holding applications only**



InterMetro Industries Corporation
Wilkes-Barre, PA 18705
570-825-2741 www.metro.com



METRO

8-SERIES CONTROLLED TEMPERATURE BASIC OPERATING GUIDELINES

1. With the POWER switch OFF, plug the supply power cord into an appropriate, grounded, receptacle. (refer to the cabinet data plate for voltage and ampere rating).
2. Ensure that the cabinet's floor duct and water pan are installed. (refer to the cabinet operating instructions). This helps to distribute the heat evenly throughout the cabinet.
3. If extra humidity is desired, fill the water pan in the floor duct of the cabinet with clean warm water. The capacity of the reservoir is about one quart (one liter).
4. Set the POWER switch to the ON position.
5. The cabinet will initially display the current temperature set point and then show the actual cabinet temperature.
6. The temperature display will continue to blink until the temperature set point is reached.
7. To change temperature set point, turn the control knob. As the knob is turned, the temperature display will show the changing temperature set point, and the "°F and °C" indicator lamps will blink. About 3 seconds after the knob is turned, the display will show the actual cabinet temperature.
8. Press and release "Recall Set Points" button to see the current temperature set point.
9. To see the current low temperature alarm set point, press and release the "Low Temp Alarm" button. To change the low temperature alarm set point, press and hold the "Low Temp Alarm" button, turn the temperature knob to the desired setting, and release the button.
10. To clean cabinet, turn power off, unplug from wall outlet, allow the cabinet to cool, remove the floor duct and pan, wipe the cabinet with a damp cloth and dry with a towel.
11. Consult the user manual for additional operation and maintenance information.



CAUTION



- ✓ UNPLUG CABINET FROM WALL. ALLOW CABINET AND WATER TO COOL. BEFORE CLEANING OR SERVICING.
- ✓ SOME SURFACES, WATER, AND ESCAPING VAPOR CAN BE HOT ENOUGH TO BURN. USE CAUTION WHEN OPENING DOORS AND WORKING IN AND AROUND THIS CABINET.
- ✓ DO NOT SPRAY OR POUR WATER INTO THE CONTROLLER ENCLOSURE. TO CLEAN CABINET, WIPE WITH A DAMP CLOTH AND DRY WITH A TOWEL.
- ✓ KEEP THE CABINET CLEAN. ACCUMULATION OF GREASE AND DIRT MAY IGNITE.

TABLE OF CONTENTS

SECTION	PAGE
I. Basic Operating Guidelines.....	Inside Front Cover
II. Safety Instructions.....	1
III. Identifying Your Cabinet	2
IV. Installation & Set-up.....	3
V. Product Features	7
VI. Operating Instructions.....	8
VII. Care & Maintenance.....	9
VIII. Basic Troubleshooting	10
IX. Service & Replacement Parts.....	11
X. Warranty.....	Inside Back Cover

SAFETY INFORMATION

WARNING: Follow all food safety guidelines. Pre-heat the cabinet to the desired temperature before placing cooked, hot food into the cabinet. This is not a re-thermalizing cabinet. Food must be at the appropriate temperature before being placed into this cabinet. Use a food probe to check internal food temperature — the cabinet temperature is not necessarily the internal food temperature.

WARNING: Only factory approved service agents should attempt to service, repair or replace electrical components, wiring or power cord.

WARNING: Unplug the cabinet before cleaning or servicing. Do not wash the cabinet with a water jet or high pressure water.

WARNING: This cabinet is for hot food holding applications only.

CAUTION: Do not spray or pour water into the top of the cabinet (control enclosure). To clean the cabinet, wipe with a damp cloth and dry with a towel. Use only cleaning agents approved for stainless steel or aluminum (depending on your cabinet construction).

CAUTION: Water dripping onto the floor from open doors can be a slip hazard.

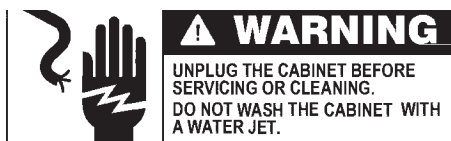
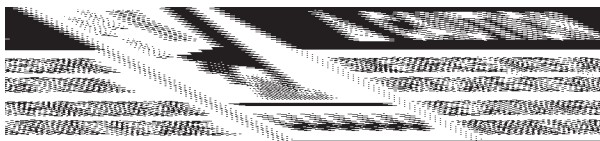

INSTALLATION AND SET-UP

1. Check for Shipping Damage: Check the packaging and cabinet for shipping damage before and after unloading the unit, and after removing all the packaging.
2. The receiver of this product is responsible for filing freight damage claims. This equipment must be opened immediately for inspection. All visible damage must be reported to the freight company within 48 hours and must be noted on freight bill at the time of delivery.
3. Concealed damage is your responsibility — you must advise the carrier of any loss or damage within 15 days after receipt of the cabinet. If there is damage, retain the original packaging for inspectors.
4. After unpacking the cabinet, remove all tape and packing material from the inside as well as outside of the unit.
5. Any protective covers (plastic or paper sheet) on the sheet metal or clear door(s), if applicable, must also be removed before turning the cabinet on.

WARNING: Only factory approved service agents should attempt to service, repair or replace electrical components, wiring or the power cord.

6. The power cord can be installed to exit the back of the cabinet for wall outlets or out the top of the cabinet for ceiling power drops. To change the position of the power cord, first make sure the cabinet power switch is off and the power cord is unplugged from any electrical outlet. Remove the (7) screws holding the cabinet top in place. Lift the rear portion of the cabinet top and slide it away from under the front control bezel, removing it from the cabinet. Remove the (2) screws on the rear of the cabinet that hold the cord bracket in place. Rotate the power cord bracket 90° to the desired position and reattach it with the (2) screws to the back of the cabinet. Make sure the green ground wire connection and the wire nuts on the black and white wires have not loosened. Do not alter the wiring of the power cord to the cabinet. Replace the cabinet top and the (7) screws holding it in place.



Cord out of the top



Cord out of the back

7. Refer to the data plate located near the power cord for the electrical specifications of cabinet. With the POWER switch OFF, plug the cord into the appropriate rated, grounded receptacle. Cabinets rated at 120V 2000W must be plugged into 125VAC 20 amp receptacle and must be used on an individual branch circuit. Cabinets rated at 120V 1440W may be plugged into either a 15 amp or 20 amp receptacle. Cabinets rated at 220-240V 1681-2000W must be plugged into a 250VAC, 15 amp receptacle.

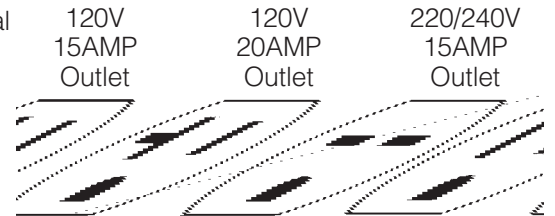

8. The factory setting for temperature is Fahrenheit. To change the temperature display from Fahrenheit to Celsius a jumper needs to be changed on the back of the controller circuit board. Turn the cabinet off, unplug the cabinet from the electrical supply and remove the top of the cabinet (refer to step #6). See the control wiring diagram below for the location of jumper JP5. For Fahrenheit control, the jumper is on the lower two pins. For Centigrade control, move the jumper from the lower two pins to the upper two pins. After changing the jumper, replace the top, plug the cabinet in, turn the cabinet on and **adjust the temperature and low temperature alarm settings for the new units (°C or °F)** of temperature selected.

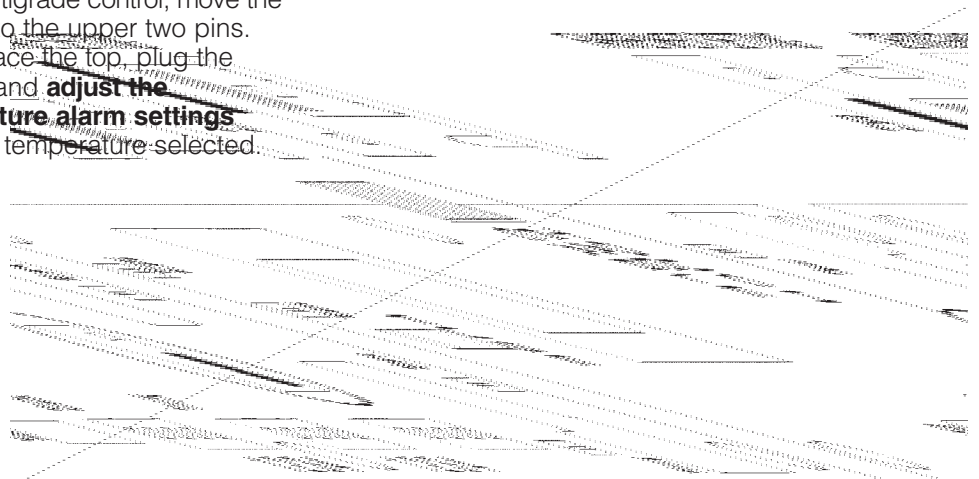

9. Your C5 cabinet is designed to operate next to walls and other kitchen equipment. However, the greater the clearance around the sides and the top of the cabinet, the cooler the electrical components will operate. This may result in a longer life expectancy for the electrical components.

WARNING: Do not allow combustible materials to be stored or accumulate on, under or next to the cabinet. Do not block any ventilation louvers or slots.

INSTALLATION AND SET-UP (continued)

SLIDE INSTALLATION

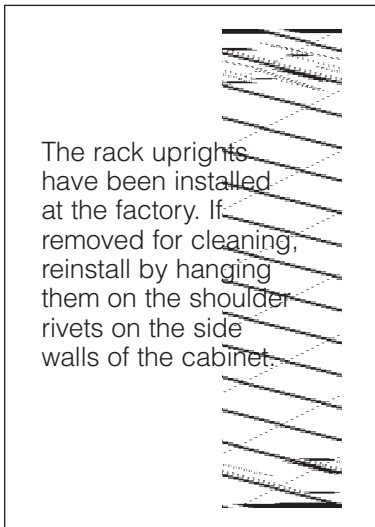

The rack uprights have been installed at the factory. If removed for cleaning, reinstall by hanging them on the shoulder rivets on the side walls of the cabinet.

TOP VIEW

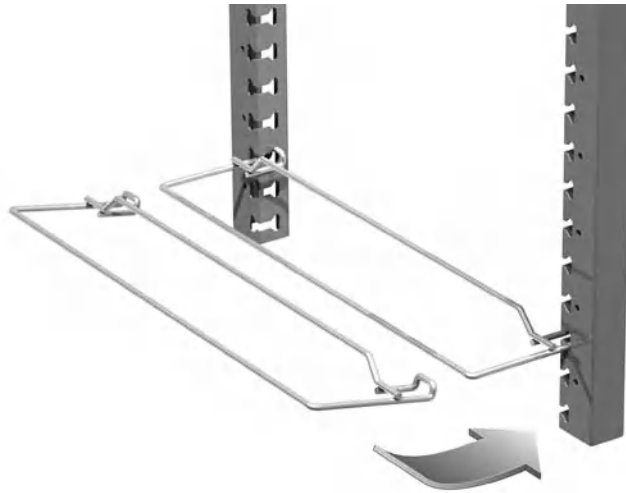

SLIDE POSITION to MAXIMIZE 3" PAN CAPACITY OF UNIVERSAL SLIDES

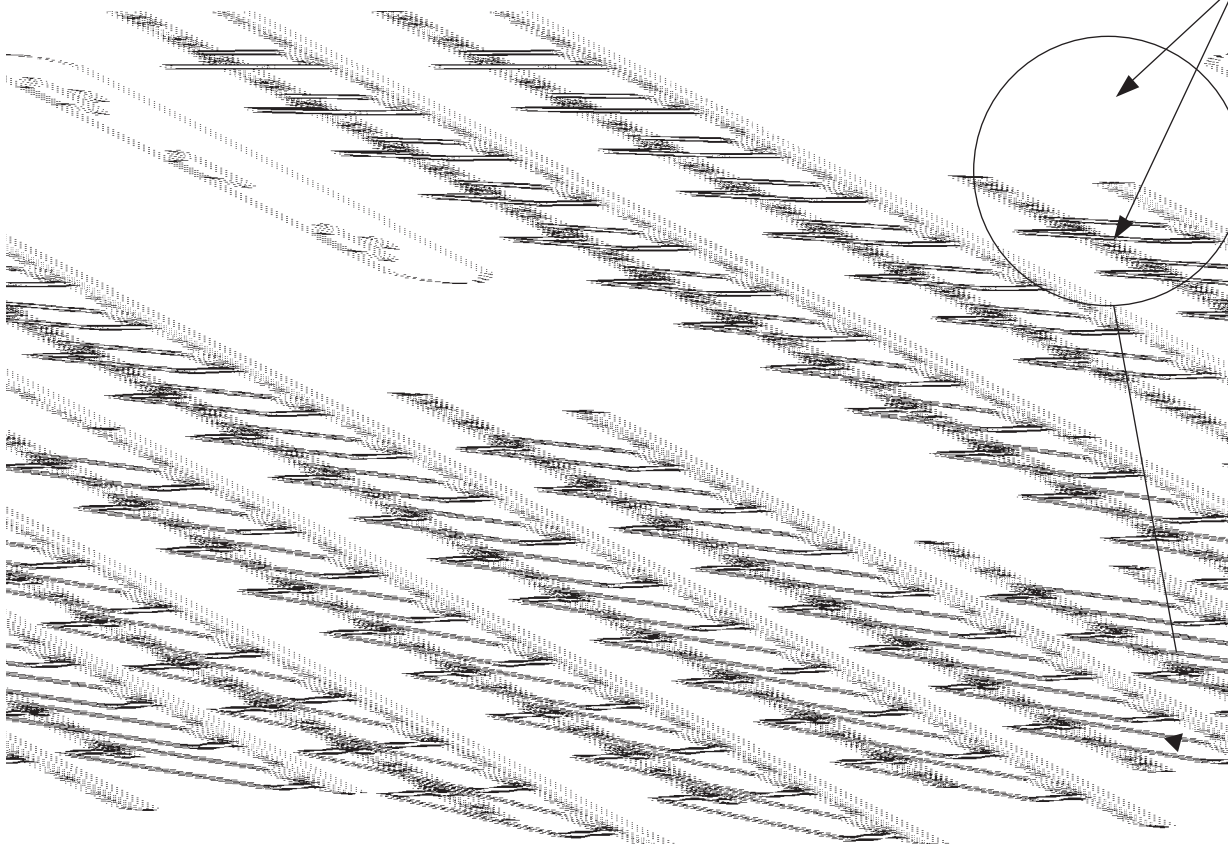

SiteSelect™ features make slide installation easier.

Full Height Single Door
18 Levels
(Position 2nd from Bottom)
Part No. C5-U-9

Full Height Dutch Doors
17 Levels
(Position Bottom)
Part No. C5-U-9

3/4 Height Cabinet
14 Levels
(Position 2nd from Bottom)
Part No. C5-U-7

1/2 Height Cabinet
8 Levels
(Position 3rd from Bottom)
Part No. C5-U-5

Under Counter Cabinet
5 Levels
(Position Bottom)
Part No. C5-U-3

Slides sold in pairs. For additional pair of wire slides, order C5-USLIDECPR.

INSTALLATION AND SET-UP (continued)

CORRECT ORIENTATION OF LIP LOADED SLIDE RACKS

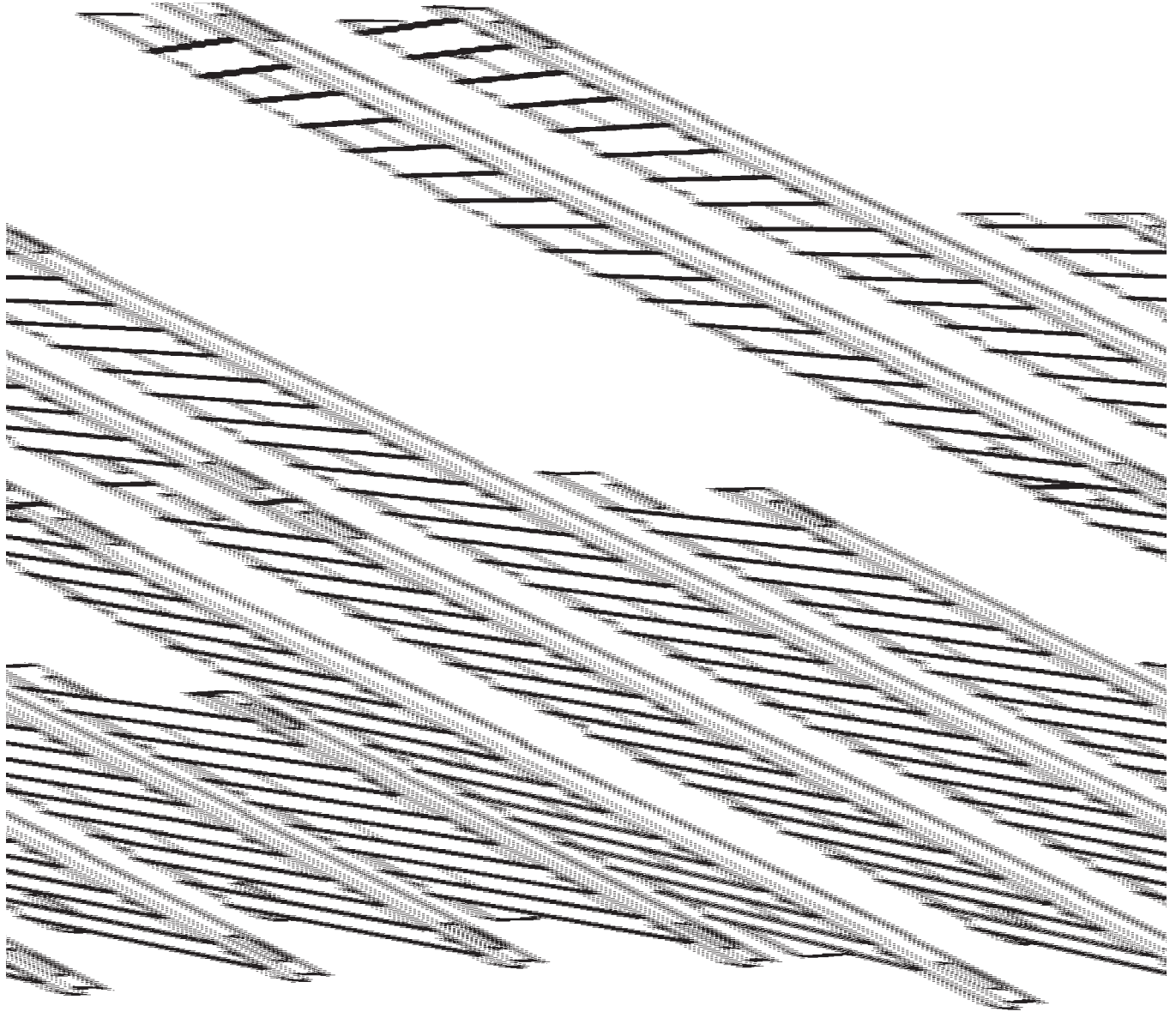

**Full Height
Single Door**

2-piece Construction
Part No. C5-L-9

**Full Height
Dutch Doors**

2-piece Construction
Part No. C5-L-9

**$\frac{3}{4}$ Height
Cabinet**

1-piece Construction
Part No. C5-L-7

**$\frac{1}{2}$ Height
Cabinet**

1-piece Construction
Part No. C5-L-5

**Under Counter
Cabinet**

1-piece Construction
Part No. C5-L-3

Slides sold in pairs.

REVERSING THE DOORS

⚠ WARNING • TIP HAZARD

Tip Hazard: On Pass-Thru cabinets that include any clear doors, when field reversing, the front and back doors must be hinged from opposite sides of the cabinet. See illustration below.

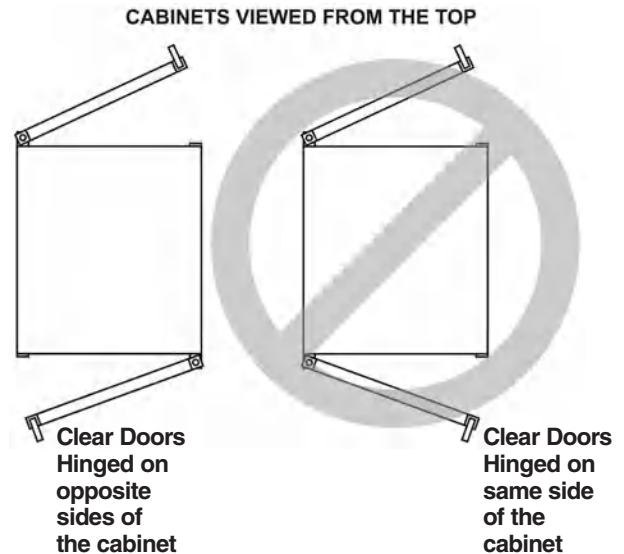
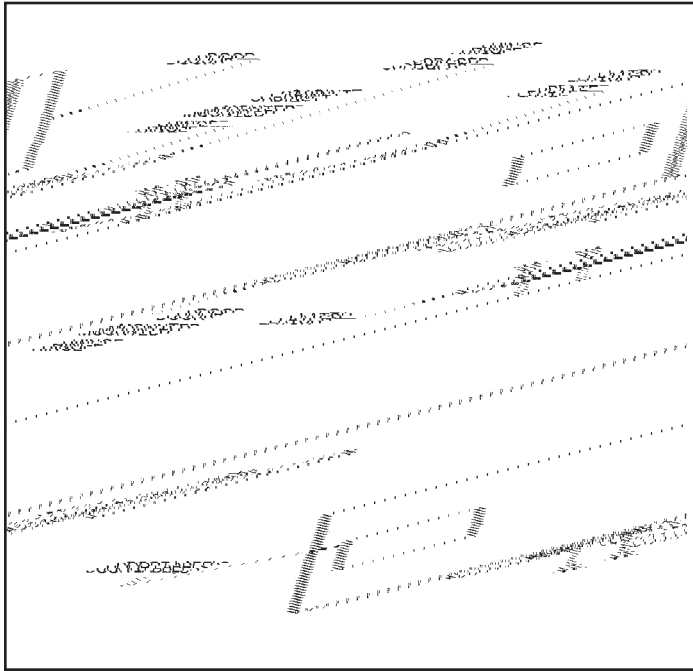

After reversing the door hinging direction, labels are now upside down. You may contact InterMetro for a new set of labels, part number RPC5-DRLBL, at no charge, to be placed in the proper orientation.

C5 doors are normally hinged on the right hand side at the factory. If the cabinet has been in operation, allow the door to cool before reversing the door hinging direction. Note: When finished, all holes will have screws in them and there will be no exposed holes left in the cabinet.

1. If the cabinet has Dutch Doors, note which is the top and which is the bottom door. Open the door, lift it off the cabinet hinges and set it aside noting which is the top and bottom of the door.
2. On the cabinet, remove the latch strike plate and hinges and install them on the other side of the cabinet. On the door, remove the hinge covers to access the mounting screws. Remove the hinges.
3. Rotate the door so the previous bottom is now the top and install the hinges. On Dutch Doors, do not remove the handles, the top door becomes the bottom and the bottom door the top. On single door units, rotate the handles 180° and reinstall.
4. On the cabinet mounted hinges, lift the white bushing and rotate it 180° and push it down to reseat it on the hinge pin.
5. Install the door onto the cabinet hinges and check to make sure the door latches properly and the gaskets are in compression.

PRODUCT FEATURES

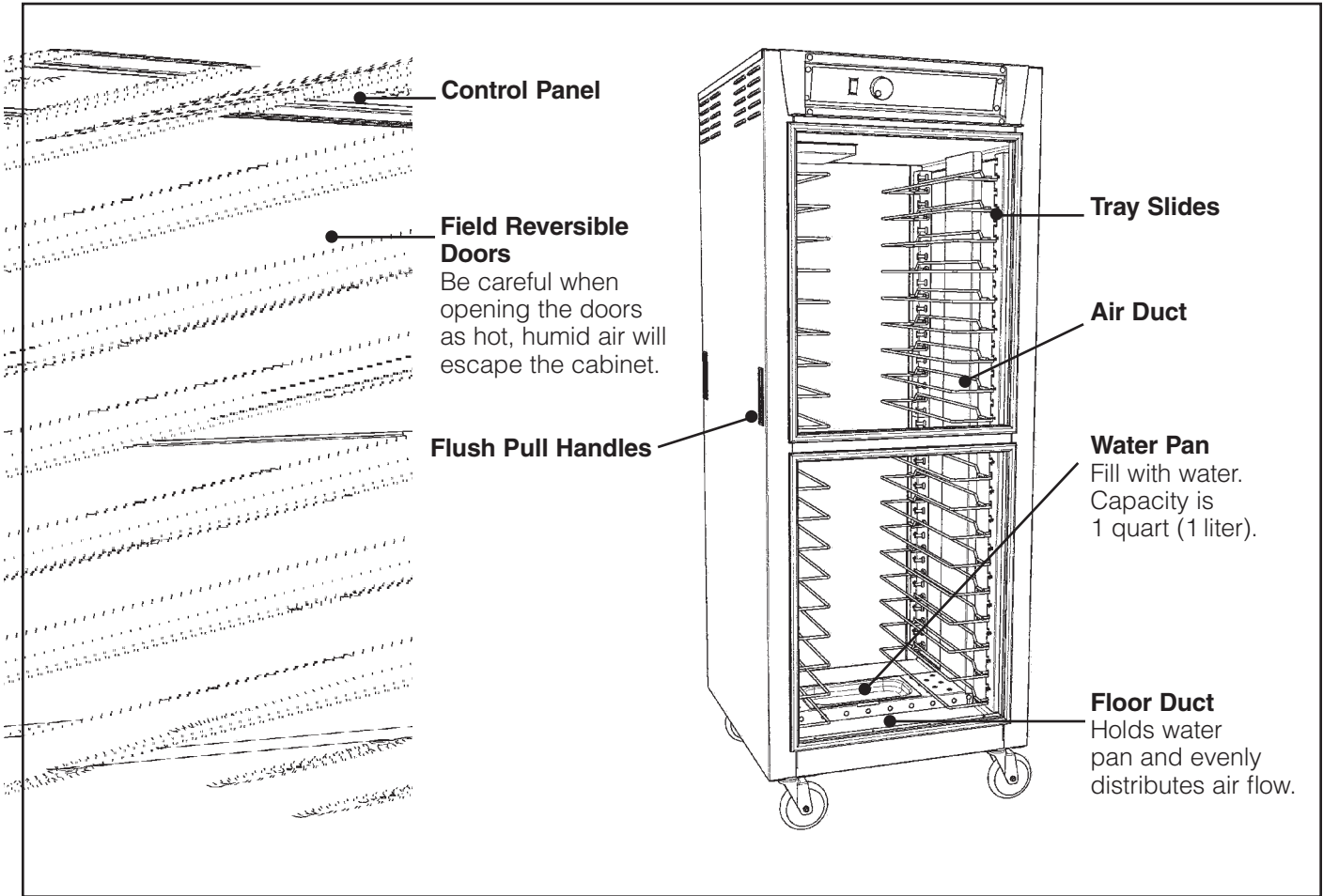

Temperature Control

Controls the temperature in the cabinet. Turn the knob to change the temperature set point. The display shows new set point as the knob is turned.

Set Point Recall

Displays cabinet's temperature set point.

Power Switch

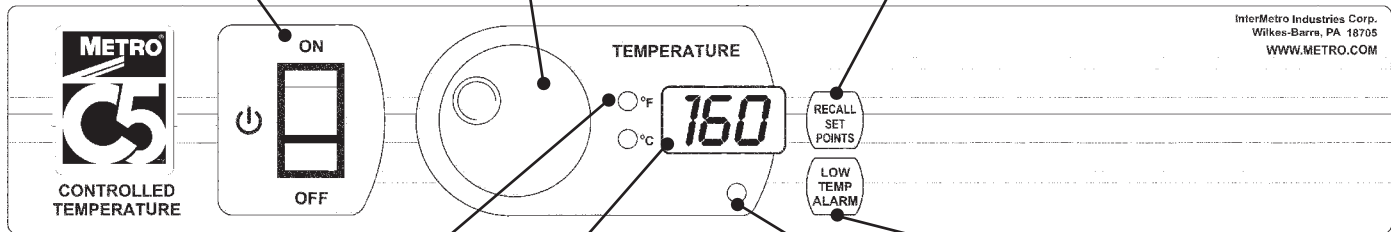

Temperature Scale Indicators

Set to Fahrenheit in the factory. These indicators will also blink while the temperature set point is being displayed.

Air Temperature Display

Displays the current cabinet temperature. Also displays low temperature warning.

Audio Disable (Sound Off)

Press "Recall Set Points" and "Low Temp Alarm" buttons simultaneously and hold for five seconds to toggle sound off and on.

Low Temperature Alarm

Sets and recalls the low temperature alarm set point.

Element Cycling Indicator Light

Indicates air heat element is on.

OPERATING INSTRUCTIONS

Power-Up & Pre-Heat

- When the cabinet is switched on, the controller displays “Set Pnt” followed by the current temperature set point. The temperature display will begin to blink, indicating that the cabinet is pre-heating. The display will stop blinking after the temperature set point is reached.
- **Factory preset is 160°F (71°C).**
- Turn “Temperature” knob at any time to change the desired setting.
- Press the “Recall Set Points” button at any time to display the current temperature setting.

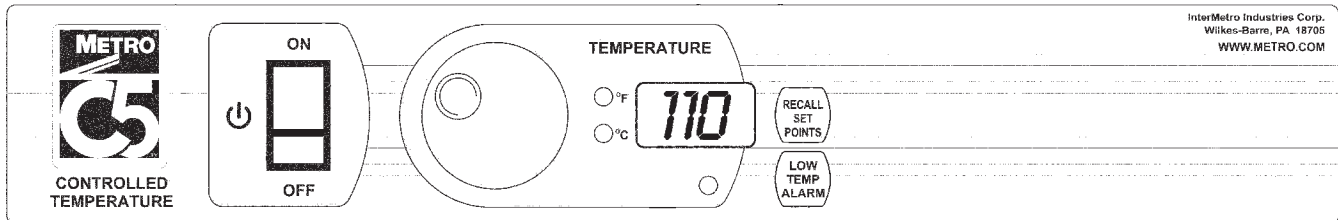

1. Allow the cabinet to pre-heat without food for 30 minutes to an hour. The time required to reach the temperature set point is dependent on the set point, the size of the cabinet, the door type (solid or clear) and the temperature of the room the cabinet is in. **Factory preset is 160°F (71°C).**

Warning: Follow all food safety guidelines. Pre-heat the cabinet to the desired temperature before putting cooked, hot food into the cabinet. This is not a re-thermalization cabinet. Food must be at the appropriate temperature before being placed into this cabinet.

Low Temperature Alarm

- The Cabinet is equipped with a low temperature alarm system that will alert you if the cabinet falls below the alarm set point for more than 5 minutes during operation (unless the low temperature alarm has been disabled — see below). The TEMPERATURE display will begin to blink “LO” alternating with the current temperature. An audible alarm will also sound 3 times every 10 seconds (See “Sound On and Off” below for more information on the audio alarm)
- **Factory preset for the low temperature alarm is 140°F (60°C).**
- To check the existing low temperature alarm set point, press and release the LOW TEMP ALARM button.
- To change the low temperature alarm set point, press and hold the LOW TEMP ALARM button while turning the TEMPERATURE knob.
- If the cabinet’s temperature set point is set below the low temperature alarm set point, the alarm is disabled.
- The low temperature alarm is also disabled during pre-heat.

Sound On and Off

Press “LOW TEMP ALARM” and “RECALL SET POINTS” and hold for 5 seconds to toggle sound off and on. Display will show “SND OFF” or “SND ON”

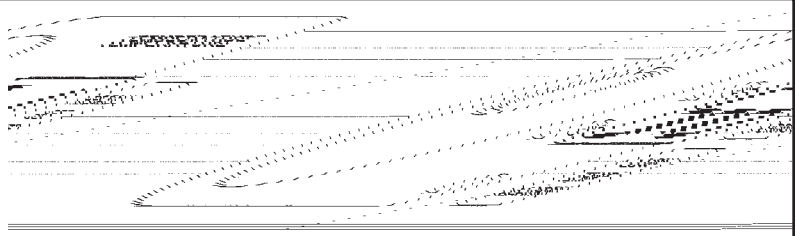

2. Your C5 8 Series cabinet is capable of creating hot humid air. As you operate the cabinet and open and close the door(s), condensation may form on the inside surfaces of the cabinet. Some dripping of water may occur to the outside of the cabinet particularly at the door seals. Water may also drip off opened doors onto the floor.

Caution: Water dripping onto the floor from open doors can be a slip hazard.

Warning: Some surfaces, water and escaping vapor can be hot enough to burn. Use caution when opening doors and working in and around this cabinet.

- The cabinet control will “remember” its setting when the cabinet is turned off. Therefore, when the unit is turned on the setting will be the same as it was during the previous use.



- A red indicator light below the digital display indicates when the temperature heater element is energized. As the control setting is adjusted, it may take a few moments for the status of the indicator light to reflect the new control setting and cabinet condition depending on when in the control cycle the setting is changed.

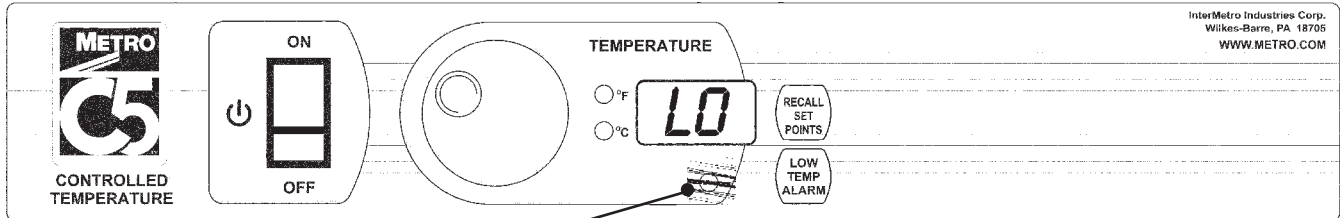

Element Indicator

- If humidity is required, fill the water pan in the bottom of the cabinet. Potable (suitable for drinking) water should be used.

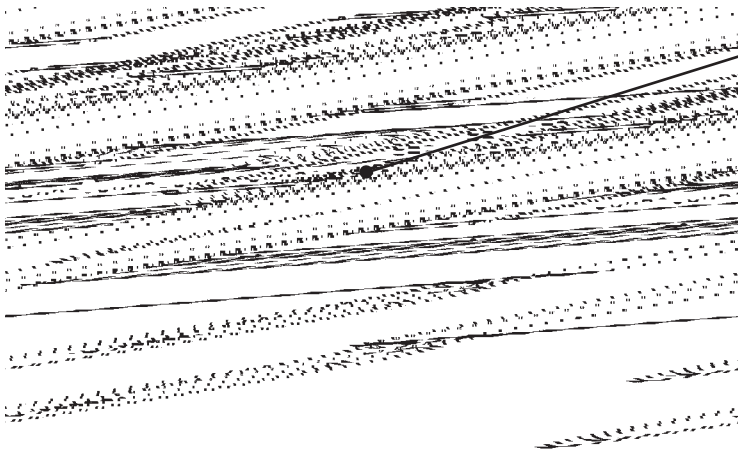

Water Pan

Fill with water. Capacity is about 1 quart (1 liter).

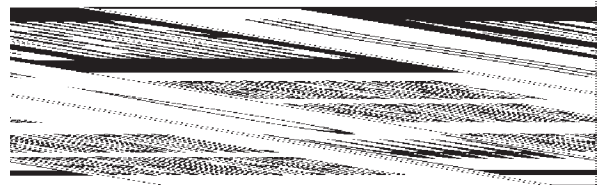

- To remove the water from the water pan, allow the cabinet and water to cool and remove the water pan.

Note: When turning the cabinet off at the end of the work day, it is recommended to leave the door(s) open to prevent heat and condensation build up within the cabinet.

Note: If the cabinet is not going to be used for an extended period of time, all water should be removed from the water pan and the cabinet completely cleaned and dried out.

CARE & MAINTENANCE

Cleaning The Cabinet

Warning: Unplug the cabinet before cleaning or servicing. Do not wash the cabinet with a water jet or high pressure water.

Caution: Do not spray or pour water into the control enclosure. To clean the cabinet, wipe with a damp cloth and dry with a towel. Use only cleaning agents approved for stainless steel or aluminum (depending on your cabinet construction).

Caution: Do not use cleaners with chlorides or phosphates as they may cause damage to stainless steel. Do not use strong alkalis on aluminum as they may discolor it.

- Use cleaners in the proper concentrations. Follow the manufacturer’s directions for the cleaning product used. After using any cleaning products, thoroughly rinse all surfaces to remove all residue.
- Use a damp cloth or sponge. Mild soap suitable for stainless steel and aluminum is acceptable. Dry with a clean towel. Wipe up spills as soon as possible and regularly clean the cabinet to avoid staining and difficult to clean conditions.

If the control knob needs to be removed for cleaning, use a 5/64" Allen key to loosen the set screw on the control knob. Remove the knob, clean the control face and/or knob and replace the knob and tighten the set screw.

BASIC TROUBLESHOOTING

Warning: Only factory approved service agents should attempt to service, repair or replace electrical components, wiring or power cord.

- 1. Controls do not work (no display or indicator light):**
 - a. Check that the cabinet is plugged in.
 - b. Check that the outlet has power.
 - c. Check that the power switch is in the "On" position.
 - d. Check the cabinet wiring from the power cord to the power switch and to the controller.
 - e. Check that the fuse on the back of the controller is not blown.
 - f. Controller is faulty.
 - 2. Controller temperature display does not change** (displays a constant value approximately equal to the minimum or maximum of the temperature control range, 70°F (21°C) or 200°F (93°C):
 - a. The temperature sensor and controller are not communicating:
 - i. Temperature sensor wires are broken or disconnected from the controller.
 - ii. Controller needs to be replaced.
 - iii. Temperature sensor needs to be replaced.
 - 3. Temperature too hot:**
 - a. Set point is too high. Turn temperature set point down to the desired temperature.
 - b. During initial pre-heat some over temperature may occur but will quickly return to the set point.
 - c. If displayed temperature exceeds 220°F (104°C):
 - i. Blower wiring is faulty or disconnected.
 - ii. Blower needs replacing.
 - iii. The thermostat may have failed and the thermal overload device is controlling the temperature. Stop using the cabinet immediately and contact a factory approved service agent.
 - 4. Temperature too low:**
 - a. The cabinet may still be in pre-heat or recovering from a door being opened.
 - b. Set point is too low. Turn temperature set point up to the desired temperature.
 - c. A door is not closed or sealing properly.
 - d. Blower is not circulating air:
 - i. Blower wiring is faulty or disconnected.
 - ii. Blower needs replacing.
 - 5. No heat generated**
 - a. If the heat indicator light is on but the cabinet does not draw approximately 16 amps for 120V 2000W units; 12 amps for 120V 1440W units; or 8 or 9 amps for 220-240V units:
 - i. Air heater element may be faulty.
 - ii. The wiring to the air heater element may be faulty or disconnected.
 - iii. The controller (air heater relay) may be faulty.
 - b. If the heat indicator light does not come on, the controller may be faulty.
 - 6. Displays blink "LO" and Alarm beeps (if "Sound" is on):**
 - a. If the temperature display alternately blinks the current cabinet temperature and then "LO", refer to steps 4 and 5.
 - 7. Cabinet trips GFCI (ground fault circuit interrupter):**

A GFCI receptacle protects against "ground faults" whenever an electrical product is plugged into the GFCI outlet by constantly monitoring the electricity for any loss of current. If the current flowing out of the receptacle differs by a small amount from that returning, the GFCI quickly switches off power to that circuit. The GFCI interrupts power extremely fast to minimize the possibility of an electric shock.

 - a. The heater element may absorb some moisture into its casing and insulation during shipment or during long periods of not being used (such as during the summer in a closed school kitchen). Plug the cabinet (without water in the water pan) into a non-GFCI outlet, set the temperature to 200°F (93°C) and let it run for 30-60 minutes to dry out any moisture the element may have absorbed. (If it trips the standard circuit breaker call factory approved service agent.) After drying the element, plug the cabinet into the GFCI outlet; the cabinet should run without tripping the GFCI.
 - b. If the cabinet still trips the GFCI, call a factory approved service agent.
-

Note: The temperature control does not require field calibration.

SERVICE and REPLACEMENT PARTS

C5 8 SERIES REPLACEMENT PARTS — ELECTRICAL

Confirm the cabinet electrical rating before ordering components.

Warning: Only factory approved service agents should attempt to service, repair or replace electrical components, wiring or power cord.

To access the controller area, remove the (7) screws holding the cabinet top in place. Lift the rear portion of the cabinet top and slide it away from under the front control bezel, removing it from the cabinet. After servicing, replace the cabinet top and the (7) screws holding it in place.

120V 1440W OR 2000W

ITEM #	Replacement Part No.	Description
1	RPC5-8CONTR	120V (°F) CONTROLLER, SENSORS & WIRING
2	RPC13-127	MASTER SWITCH
3	RPC5-KNOB	CONTROLLER KNOB
4	RPC11-191	INTAKE COLLAR
5	RPHM20-2103	BLOWER, 120V
6	RPC13-093	ELEMENT, 120V 1950W
6A	RPC13-114	ELEMENT, 120V 1360W
7	RPC13-198	THERMAL CUT OUT
8	RPC13-099	POWER CORD, 120V 20A
	RPC13-217	CORD, TWIST LOCK PLUG, 20A
	RPQC13-001	CORD, RT ANGLE PLUG, 20A
8A	RPC13-017	POWER CORD, 120V 15A
9	RPC13-098	STRAIN RELIEF, 20A CORD
9A	RPC13-083	STRAIN RELIEF, 15A CORD
10	RPC13-096	TERMINAL BLOCK
11	RPC07-055	SENSOR CABLE GROMMET
12	RPC5-SCLP	SENSOR CLAMP & SCREW

220-240V 1681W OR 2000W

ITEM #	Replacement Part No.	Description
1	RPC5X-8CONTR	220-240V (°C) CONTROLLER, SENSORS & WIRING
2	RPC13-127	MASTER SWITCH
3	RPC5-KNOB	CONTROLLER KNOB
4	RPC11-191	INTAKE COLLAR
5	RPHX20-2103	BLOWER, 220V-240V
6	RPC13-117	ELEMENT, 240V 1950W
7	RPC13-198	THERMAL CUT OUT
8	RPC13-247	POWER CORD, 250V 15A
9	RPC13-083	STRAIN RELIEF, 15A CORD
10	RPC13-096	TERMINAL BLOCK
11	RPC07-055	SENSOR CABLE GROMMET
12	RPC5-SCLP	SENSOR CLAMP & SCREW

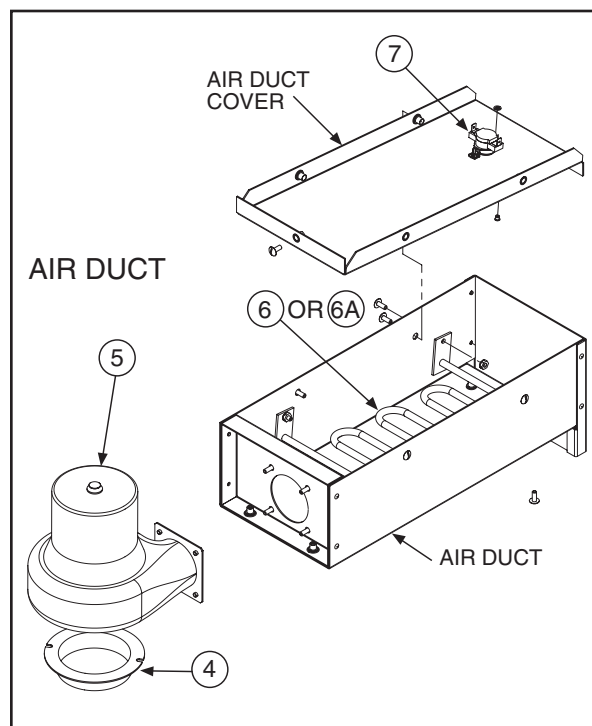
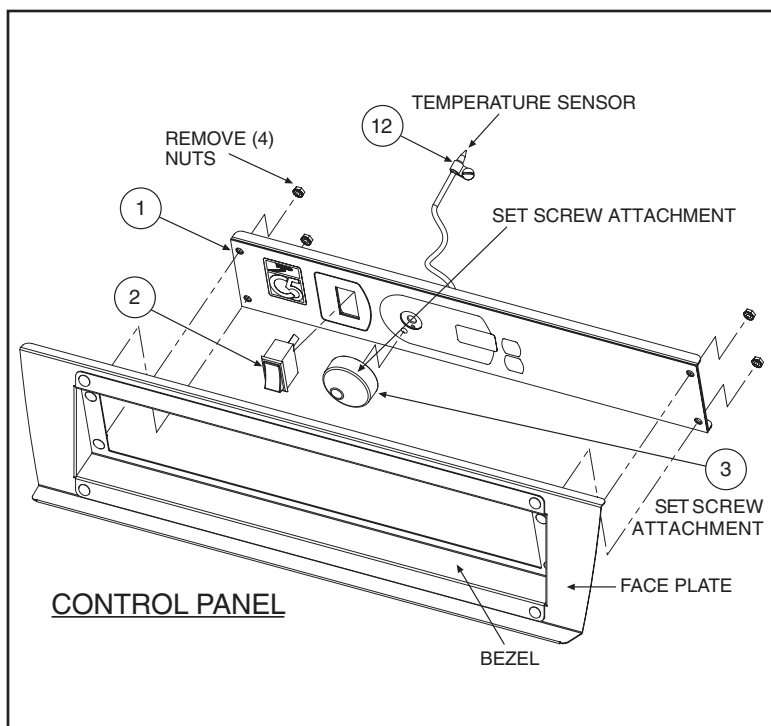

SERVICE and REPLACEMENT PARTS (continued)

C5 8 SERIES REPLACEMENT PARTS — CABINET BODY

ITEM #	Replacement Part No.	Description	ITEM #	Replacement Part No.	Description
CABINET BODY			CABINET BODY (continued)		
13	RPC06-873B	FULL HEIGHT DOOR GASKET	15	RPC11-274	DOOR LATCH — 1 PIECE
	RPC06-873C	3/4 HEIGHT DOOR GASKET		RPC14-118A	FLUSH HANDLE DOOR LATCH — 1 PIECE
	RPC06-873A	1/2 HEIGHT & DUTCH DOOR GASKET		RPC14-251	DOOR LATCH WITH TWIST LOCK — 1 PIECE
	RPC06-873D	UNDER COUNTER DOOR GASKET	16	RPC14-042	DOOR HINGE — 1 PIECE
14	RPC5-S9DR	STAINLESS STEEL FULL HEIGHT SOLID DOOR	17	B5DNB	5" BRAKE CASTER
	RPC5-S7DR	STAINLESS STEEL 3/4 HEIGHT SOLID DOOR		B3B	3" BRAKE CASTER
	RPC5-S5DR	STAINLESS STEEL 1/2 HEIGHT & BOT D SOLID DOOR		RPQC02-248	6" BRAKE CASTER
	RPC5-S9TDDR	STAINLESS STEEL TOP DUTCH SOLID DOOR	18	B5DN	5" SWIVEL CASTER
	RPC5-S3DR	STAINLESS STEEL UNDER COUNTER SOLID DOOR		B3	3" SWIVEL CASTER
	RPC5-N9DR	ALUMINUM FULL HEIGHT SOLID DOOR		B5DRN	5" RIGID CASTER
	RPC5-N7DR	ALUMINUM 3/4 HEIGHT SOLID DOOR		RPQC02-247	6" SWIVEL CASTER
	RPC5-N5DR	ALUMINUM 1/2 HEIGHT & BOT D SOLID DOOR	19	RPC11-481	WATER PAN
	RPC5-N9TDDR	ALUMINUM TOP DUTCH SOLID DOOR	20	RPC06-872	POCKET HANDLE
	RPC5-N3DR	ALUMINUM UNDER COUNTER SOLID DOOR	*21	C5-L-9	TALL CABINET LIP LOADED SLIDE ASSEMBLY
	RPC5-S9CDR	STAINLESS STEEL FULL HEIGHT CLEAR DOOR		C5-L-7	3/4 HEIGHT CABINET LIP LOADED SLIDE ASSEMBLY
	RPC5-S7CDR	STAINLESS STEEL 3/4 HEIGHT CLEAR DOOR		C5-L-5	1/2 HEIGHT CABINET LIP LOADED SLIDE ASSEMBLY
	RPC5-S5CDR	STAINLESS STEEL 1/2 HEIGHT & BOT D CLEAR DOOR		C5-L-3	UNDER COUNTER CABINET LIP LOADED SLIDE ASSEMBLY
	RPC5-S9CTDDR	STAINLESS STEEL TOP DUTCH CLEAR DOOR	*22	C5-U-9	TALL CABINET UNIVERSAL SLIDE ASSEMBLY (INCLUDES WIRE SLIDES & UPRIGHTS)
	RPC5-S3CDR	STAINLESS STEEL UNDER COUNTER CLEAR DOOR		C5-U-7	3/4 HEIGHT CABINET UNIVERSAL SLIDE ASSEMBLY (INCLUDES WIRE SLIDES & UPRIGHTS)
	RPC5-N9CDR	ALUMINUM FULL HEIGHT CLEAR DOOR		C5-U-5	1/2 HEIGHT CABINET UNIVERSAL SLIDE ASSEMBLY (INCLUDES WIRE SLIDES & UPRIGHTS)
	RPC5-N7CDR	ALUMINUM 3/4 HEIGHT CLEAR DOOR		C5-U-3	UNDER COUNTER CABINET UNIVERSAL SLIDE ASSEMBLY (INCLUDES WIRE SLIDES & UPRIGHTS)
	RPC5-N5CDR	ALUMINUM 1/2 HEIGHT & BOT D CLEAR DOOR	23	C5-USLIDECPR	UNIVERSAL WIRE SLIDES — 1 PAIR
	RPC5-N9CTDDR	ALUMINUM TOP DUTCH CLEAR DOOR	24	RPC5-SSLEG-1	EQUIPMENT LEG — QTY. 1
	RPC5-N3CDR	ALUMINUM UNDER COUNTER CLEAR DOOR	25	RPC5-DRLBL	DOOR LABELS — QTY. 2 (USED WHEN REVERSING DOORS)
			26	C5-SHELF	ACCESSORY SHELF (USED WITH UNIVERSAL UPRIGHTS)

*See pages 4 and 5 for slide identification.
All slides sold as pairs.

SERVICE and REPLACEMENT PARTS (continued)

Replacement Parts Diagram

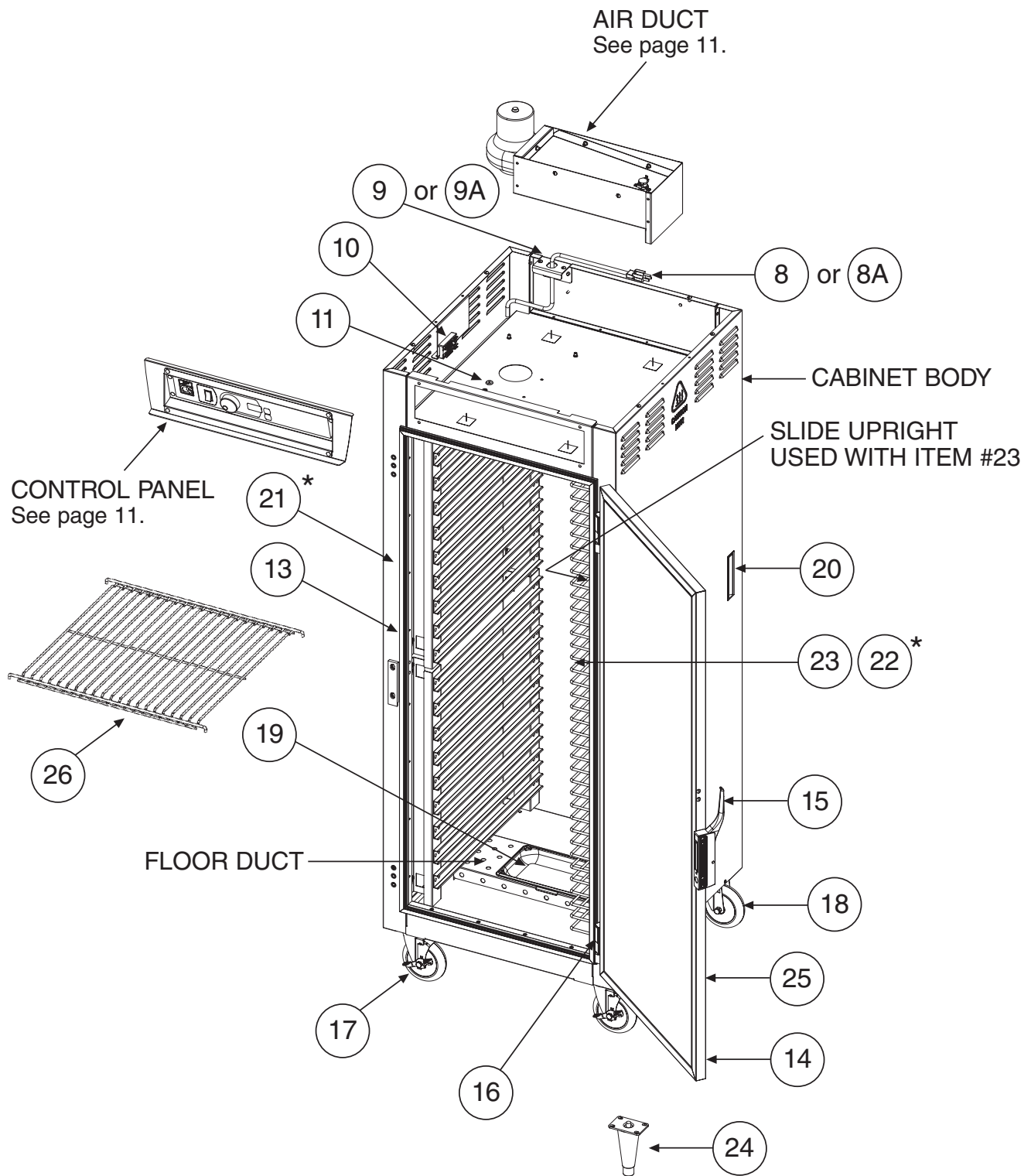

*For slide identification, see pages 4 and 5.

SERVICE and REPLACEMENT PARTS (continued)

Wiring Diagram

Warning: Only factory approved service agents should attempt to service, repair or replace electrical components, wiring or power cord.

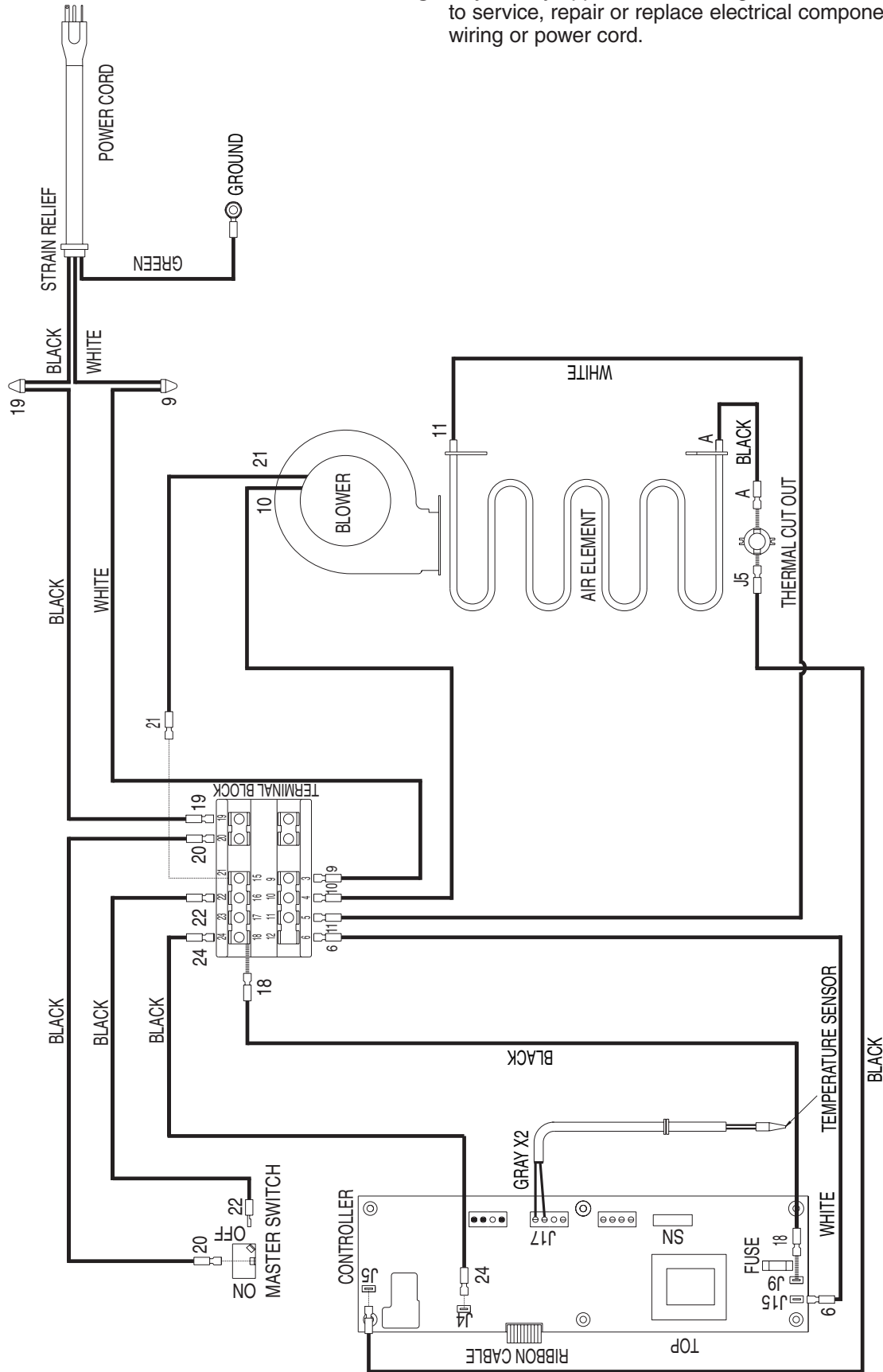

Thank you for purchasing a Metro C5 Controlled Temperature Cabinet. We are certain you will be more than satisfied with its quality and performance. Please fill in the warranty information space below so we may register your warranty. Also, so that we may learn more about our customers and hopefully be of continued service in the future, please take a moment to fill in the customer information space below.

Thank You

CUT ALONG DOTTED LINE

CUSTOMER INFORMATION

1. Which one of the following best describes your establishment?

- a. Full-Service Restaurant
- b. Banquet Hall
- c. Hotel/Motel
- d. Hospital/Nursing Home
- e. College/University
- f. School
- g. Employee Feeding
- h. Other _____

WARRANTY INFORMATION:

Cabinet Model No. _____
Cabinet Serial No. _____
Date Purchased _____
Customer Name _____
Address _____

Phone No. _____

For warranty coverage, this card must be returned to Metro.

FOLD HERE — DO NOT DETACH

2. Please indicate the two product benefits that were of major interest to you.

- a. Easy-to-use controls
- b. Door selection
- c. Size Selection
- d. Cabinet capacity
- e. Slide selection
- f. Easy-to-clean design
- g. Other _____

3. Main factor that led to your decision to purchase this product?

- a. Product operating and functional features
- b. Overall quality
- c. Price
- d. Availability
- e. Other _____

4. Three sources that led to the purchase of his product — in the order of their impact (1 — being most impact; 3 — being least impact).

- a. Trade Journal Ad
- b. Trade Show
- c. Sales Call
- d. Direct Mail
- e. Previous Purchase
- f. Other _____

CUT ALONG DOTTED LINE



WILKES-BARRE PA 18705-9968

P O BOX A

ATTN: CUSTOMER SERVICE

INTERMETRO INDUSTRIES CORPORATION

POSTAGE WILL BE PAID BY

FIRST-CLASS PERMIT NO. 121 WILKES-BARRE, PA

BUSINESS REPLY MAIL

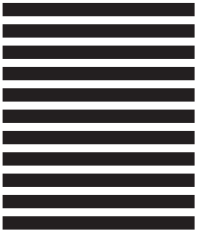

NO POSTAGE
NECESSARY
IF MAILED
IN THE
UNITED STATES

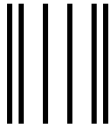

FOLD HERE — DO NOT DETACH

STAPLE HERE

STAPLE HERE

STAPLE HERE

Warranty

WARRANTY, EXCLUSION OF WARRANTIES AND LIMITATION OF LIABILITY.

InterMetro Industries Corporation (hereinafter referred to as "Seller") warrants to the original purchaser that all products in its catalog, or custom products, delivered hereunder will be free from defects in workmanship and material. THE FOREGOING WARRANTY IS EXCLUSIVE AND IN LIEU OF ALL OTHER WARRANTIES, EXPRESS, IMPLIED OR STATUTORY, INCLUDING ANY WARRANTY OF MERCHANTABILITY OR FITNESS FOR A PARTICULAR PURPOSE. This Warranty shall be for a period of one (1) year from the date of shipment from Seller's warehouse or factory. If any product delivered hereunder does not meet the Warranty specified above, providing the product has not been altered in any way by anyone other than Seller's factory-authorized representative, and assuming normal and proper use and maintenance, Seller will, at its option, repair or replace any part or material it determines, upon inspection, to be defective; provided however, that a charge for labor will be made except during a period of one (1) year from the date of original shipment from Seller's warehouse or factory. No product, or part thereof, is to be returned to Seller without prior written approval from Seller's factory. All exchanges and replacement shipments will be F.O.B. Seller's factory. Warranties for equipment or articles not manufactured by the Seller are solely the warranties of the manufacturers thereof and they are hereby assigned to the purchaser without recourse to the Seller.

SELLER'S LIABILITY FOR ANY CLAIM OF ANY KIND, WHETHER BASED ON CONTRACT, NEGLIGENCE OR STRICT LIABILITY IN TORT, AND BY WHOMEVER MADE, FOR ANY DIRECT, INDIRECT, INCIDENTAL OR CONSEQUENTIAL LOSS, DAMAGE OR INJURY, RESULTING TO THE PURCHASER OR ANY THIRD PARTIES, arising out of, connected with or resulting from this Agreement, or from the performance or breach thereof, or from the manufacture, sale, delivery, resale, installation, inspection, repair or use of any product covered by or furnished under this Agreement, WHETHER OR NOT CAUSED BY SELLER'S NEGLIGENCE, SHALL IN ALL EVENTS BE EXCLUSIVELY LIMITED TO THE COST OF CORRECTING DEFECTIVE, DAMAGED OR NON-CONFORMING PARTS OR MATERIAL AS HEREIN PROVIDED, and upon the expiration of one (1) year, all such liability shall terminate.

SELLER DOES NOT AUTHORIZE any person to assume for it any obligations or liabilities greater than or different than those set forth in this Warranty. The terms under which any of Seller's products may be resold must be limited in accordance with this Warranty.

THIS AGREEMENT, and all the rights and obligations arising hereunder, shall be construed in accordance with, and be governed by, the law of the Commonwealth of Pennsylvania, U.S.A.

TO INSURE WARRANTY implementation, return the completed registration card within 15 days of cabinets' receipt to: InterMetro Industries Corp., Wilkes-Barre, PA 18705



InterMetro Industries Corporation
Wilkes-Barre, PA 18705



InterMetro Industries Corporation

North Washington Street, Wilkes-Barre, PA 18705

For Product Information Call: 1-800-433-2232

Visit Our Web Site: www.metro.com

L01-425
Rev. A 4/08

Information and specifications are subject to change
without notice. Please confirm at time of order.