

SECTION 6: PARTS SECTION

SECTION 6: PARTS SECTION
AJ-54 CONTROL BOX ASSEMBLY

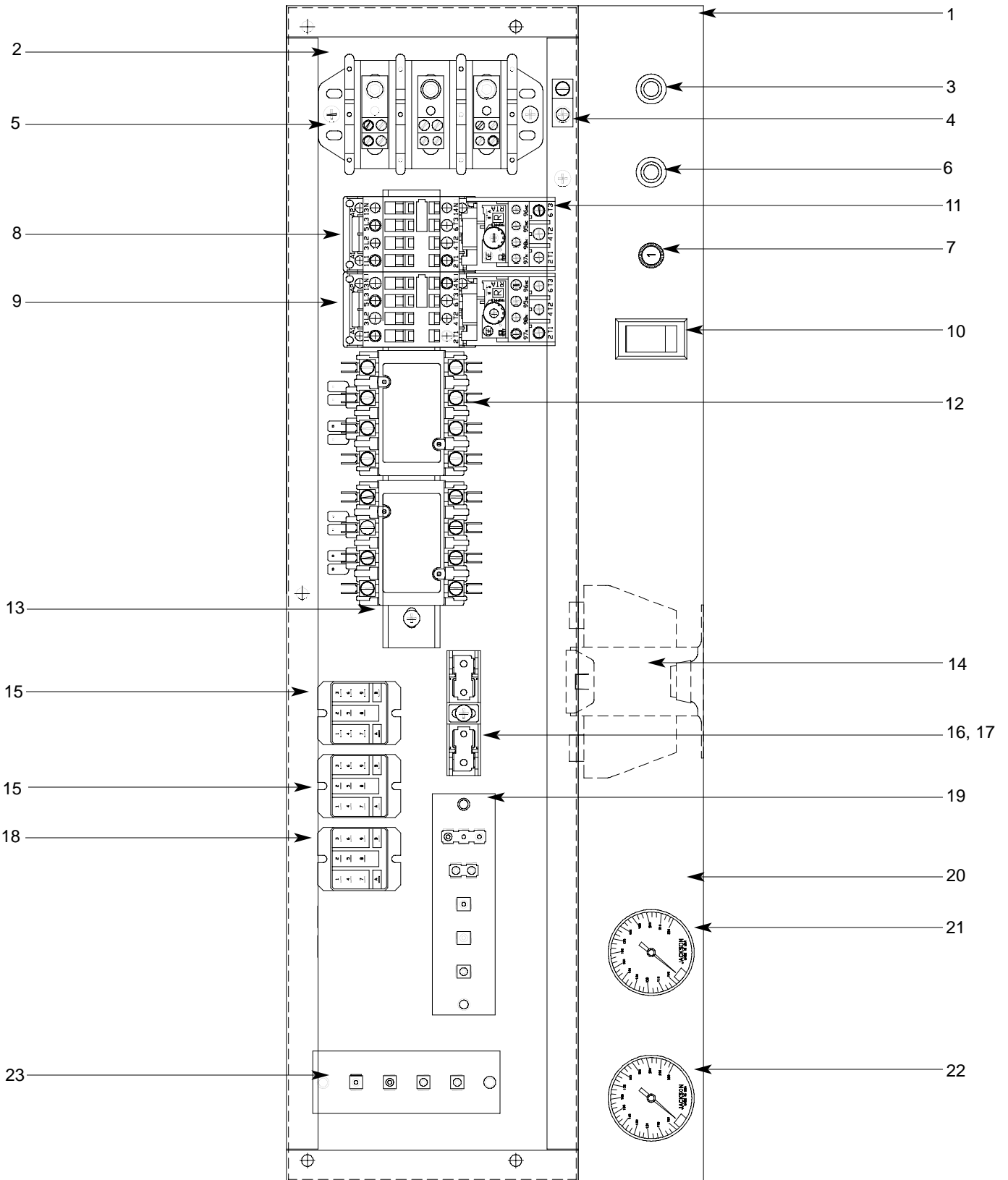

SECTION 6: PARTS SECTION
AJ-54 CONTROL BOX ASSEMBLY (CONTINUED)

ITEM	QTY	DESCRIPTION	Mfg. No.
1	1	Electrical Box Weldment	05700-041-88-43
2	1	Electrical Plate	05700-031-67-03
3	1	Light, Amber	05945-111-44-44
4	1	Ground Lug	05940-200-76-00
5	1	Terminal Block	05940-011-48-27
6	1	Light, Red	05945-111-44-45
7	1	Circuit Breaker (208 & 230 Volt Models Only)	05925-011-68-34
8	1	Motor Contactor	05945-111-68-38
9	1	Motor Contactor	05945-111-68-38
10	1	Switch, Manual Wash	05930-301-46-00
11	1	Overload	See Chart
12	2	Heater Contactor (Electrically-Heated Models Only)	05945-002-24-70
13	1	Din Rail, 5-3/4" Long	05700-021-72-75
14	1	Transformer	05950-011-68-35
	1	Transformer (575/600 Volt Models Only)	05950-002-23-77
15	2	Relay, Top Mount	05945-111-72-51
16	1	Fuse Holder (460/575/600 Volt Models Only)	05920-011-72-89
17	1	Fuse (460/575/600 Volt Models Only)	05920-011-72-88
18	1	Control Relay	05945-111-35-19
19	1	Terminal Board	05940-021-70-70
20	1	Control Box Decal	09905-021-72-29
21	1	Thermometer, Wash	06685-111-68-48
	1	Decal, Wash 160°F	09905-003-00-69
22	1	Thermometer, Rinse	06685-111-68-49
	1	Decal, Rinse 180°F	09905-002-97-62
23	1	Terminal Board, Screw Down	05940-021-89-41

Items not shown:

Grommet, 1/2" OD x 3/8" ID	05325-011-46-73
Bushing, Heyco SB100	05975-210-09-00
Plug, Heyco 2700 G-875	05975-011-47-81
Control Box Cover	05700-031-66-88
Control Box Cover Hinge Weldment	05700-021-68-57
Control Hinge Rod	05700-011-68-58
MANUAL/DELIME Switch (Located on rear of control box)	05930-301-22-18
MANUAL/DELIME Decal	09905-011-74-61
Copper Conductors Only Decal	09905-011-47-35
Control Box Leg	05700-011-71-47

SECTION 6: PARTS SECTION

AJ-76 & AJ-90 CONTROL BOX ASSEMBLY

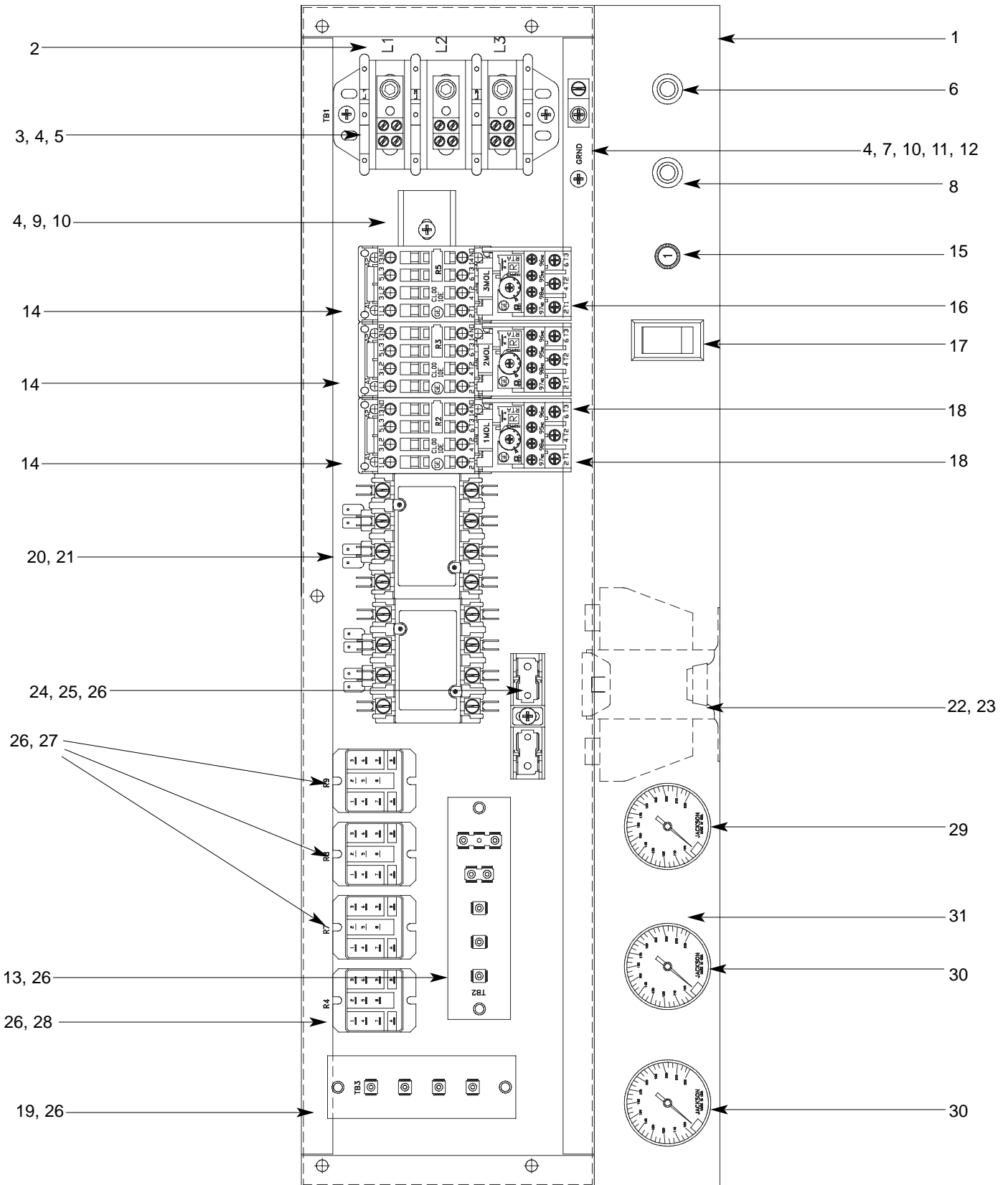

SECTION 6: PARTS SECTION

AJ-76 & AJ-90 CONTROL BOX ASSEMBLY (CONTINUED)

ITEM	QTY	DESCRIPTION	Mfg. No.
1	1	Electrical Box Weldment	05700-041-88-50
2	1	Decal, L1-L2-L3	09905-101-12-66
3	1	Terminal Block	05940-011-48-27
4	6	Lockwasher, #10	05311-273-02-00
5	2	Screw, 10-32 x 3/4" Long Phillips Trusshead	05305-011-62-17
6	1	Light, Amber	05945-111-44-44
7	1	Wire Lug, 2 AWG to 14 AWG	05940-200-76-00
8	1	Light, Red	05945-111-44-45
9	1	Din Rail	05700-021-94-96
10	3	Screw, 10-32 x 1/2" Long Phillips Trusshead	05305-011-39-36
11	1	Washer, Flat, 1/4"	05311-174-01-00
12	1	Decal, Ground	09905-011-86-86
13	1	Terminal Board	05940-021-70-70
14	3	Motor Contactor	05945-111-68-38
15	1	Circuit Breaker (208 & 230 Volt Models Only)	05925-011-68-34
16	1	See Motor Overloads Chart	N/A
17	1	Switch, ON/FILL & OFF/DRAIN	05930-011-49-55
18	1	See Motor Overloads Chart	N/A
19	1	Terminal Board	05940-021-89-41
20	2	Heater Contactor (Not Available on Steam Models)	05945-002-24-70
21	2	Screw, 10-32 x 3/8" Long Phillips Trusshead	05305-173-12-00
22	1	Transformer	05950-011-68-35
	1	Transformer (575/600 Volt Models Only)	05950-002-23-77
23	4	Locknut, 10-24 with Nylon Insert	05310-373-01-00
24	1	Fuse Holder (460/575/600 Volt Models Only)	05920-011-72-89
25	1	Fuse (460/575/600 Volt Models Only)	05920-011-72-88
26	12	Screw, 6-32 x 3/8" Long Phillipshead	05305-171-02-00
27	3	Control Relay	05945-111-35-19
28	1	Relay	05945-111-72-51
29	1	Thermometer, Prewash	06685-111-68-49
30	2	Thermometer, Rinse/Wash	06685-111-87-13
	1	Decal, Wash 160°F	09905-003-00-69
	1	Decal, Rinse 180°F	09905-002-97-62
31	1	Decal, Gauge	09905-021-72-30

Items not shown:

Grommet, 1/2" OD x 3/8" ID	05325-011-46-73
Bushing, Heyco SB100	05975-210-09-00
Plug, Heyco 2700 G-875	05975-011-47-81
Control Box Cover	05700-031-66-88
Control Box Cover Hinge Weldment	05700-021-68-57
Control Hinge Rod	05700-011-68-58
MANUAL/DELIME Switch (Located on rear of control box)	05930-301-22-18
MANUAL/DELIME Decal	09905-011-74-61
Copper Conductors Only Decal	09905-011-47-35
Control Box Leg	05700-011-71-47

SECTION 6: PARTS SECTION**MOTOR OVERLOADS**

<u>Model</u>	<u>Volts</u>	<u>Hz</u>	<u>Phase</u>	<u>Drive Motor</u>	<u>Prewash Motor</u>	<u>Wash Motor</u>
AJ-54CE	208	60	1	N/A	N/A	N/A
AJ-54CE	230	60	1	N/A	N/A	N/A
AJ-54CE	208	60	3	05945-111-68-39	N/A	05945-111-68-40
AJ-54CE	230	60	3	05945-111-68-39	N/A	05945-111-68-40
AJ-54CE	460	60	3	05945-111-68-39	N/A	05945-111-68-40
AJ-54CE	575	60	3	05945-111-69-12	N/A	05945-111-68-41
AJ-54CE	600	60	3	05945-111-69-12	N/A	05945-111-81-33
AJ-54CS	208	60	1	N/A	N/A	N/A
AJ-54CS	230	60	1	N/A	N/A	N/A
AJ-54CS	208	60	3	05945-111-68-39	N/A	05945-111-68-40
AJ-54CS	230	60	3	05945-111-68-39	N/A	05945-111-68-40
AJ-54CS	460	60	3	05945-111-68-39	N/A	05945-111-68-40
AJ-54CS	575	60	3	05945-111-69-12	N/A	05945-111-68-41
AJ-54CS	600	60	3	05945-111-69-12	N/A	05945-111-81-33
AJ-76CE	208	60	1	N/A	N/A	N/A
AJ-76CE	230	60	1	N/A	N/A	N/A
AJ-76CE	208	60	3	05945-111-68-39	05945-111-68-41	05945-111-68-40
AJ-76CE	230	60	3	05945-111-68-39	05945-111-68-41	05945-111-68-40
AJ-76CE	460	60	3	05945-111-68-39	05945-111-68-41	05945-111-68-40
AJ-76CE	575	60	3	05945-111-69-12	05945-111-68-41	05945-111-68-41
AJ-76CE	600	60	3	05945-111-69-12	05945-111-68-41	05945-111-81-33
AJ-76CS	208	60	1	N/A	N/A	N/A
AJ-76CS	230	60	1	N/A	N/A	N/A
AJ-76CS	208	60	3	05945-111-68-39	05945-111-68-41	05945-111-68-40
AJ-76CS	230	60	3	05945-111-68-39	05945-111-68-41	05945-111-68-40
AJ-76CS	460	60	3	05945-111-68-39	05945-111-68-41	05945-111-68-40
AJ-76CS	575	60	3	05945-111-69-12	05945-111-68-41	05945-111-68-41
AJ-76CS	600	60	3	05945-111-69-12	05945-111-68-41	05945-111-68-41
AJ-90CE	208	60	1	N/A	N/A	N/A
AJ-90CE	230	60	1	N/A	N/A	N/A
AJ-90CE	208	60	3	05945-111-68-39	05945-111-68-41	05945-111-68-40
AJ-90CE	230	60	3	05945-111-68-39	05945-111-68-41	05945-111-68-40
AJ-90CE	460	60	3	05945-111-68-39	05945-111-68-41	05945-111-68-40
AJ-90CE	575	60	3	05945-111-69-12	05945-111-68-41	05945-111-68-41
AJ-90CE	600	60	3	05945-111-69-12	05945-111-68-41	05945-111-81-33
AJ-90CS	208	60	1	N/A	N/A	N/A
AJ-90CS	230	60	1	N/A	N/A	N/A
AJ-90CS	208	60	3	05945-111-68-39	05945-111-68-40	05945-111-68-40
AJ-90CS	230	60	3	05945-111-68-39	05945-111-68-40	05945-111-68-40
AJ-90CS	460	60	3	05945-111-68-39	05945-111-68-40	05945-111-68-40
AJ-90CS	575	60	3	05945-111-69-12	05945-111-68-41	05945-111-68-41
AJ-90CS	600	60	3	05945-111-69-12	05945-111-68-41	05945-111-81-33

SECTION 6: PARTS SECTION

HEATER ASSEMBLY

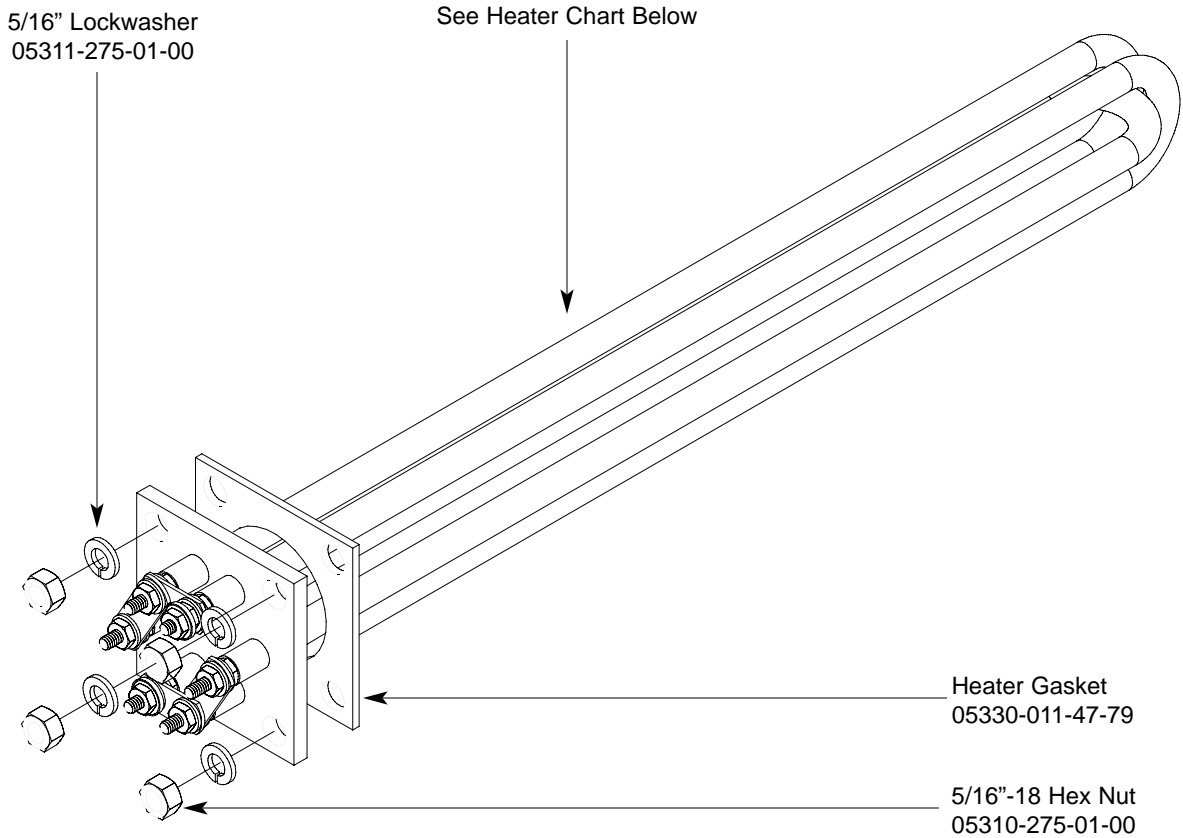

Heater Chart

<u>Model</u>	<u>Volts</u>	<u>Phase</u>	<u>KW</u>	<u>Part Number</u>
All*	208	1	10	06401-003-12-94
	230	1	10	06401-003-12-95
	208	3	10	06401-003-12-94
	230	3	10	06401-003-12-95
	460	3	10	06401-003-12-96
	575	3	10	06401-003-12-97
	575	3	18	04540-003-06-22
	600	3	10	06401-003-12-97

* - AJ-54CGP, AJ-54CS, AJ-76CGP, AJ-76CS and AJ-90CS models do not use electric heaters in the wash tank or power rinse tank.

SERVICE NOTE: When replacing the tub heaters, it is HIGHLY recommended that you also change out the gasket as well. Once installed, gaskets become compressed and are subjected to extreme temperature changes. Replacing the gasket with a new one when replacing the heater may prevent future leaks.

SERVICE NOTE: The nuts used to secure the heater to the tub should be torqued to 16 in-lbs. After tightening, the unit should be allowed to heat up and operate normally for approximately 30 minutes. Secure power to the machine and check the nuts once more to ensure that they are torqued to 16 in-lbs.

SECTION 6: PARTS SECTION

HEATER ASSEMBLY (CONTINUED)

The wash tank heater system is electrically connected in the circuit so that they are dependent upon the dishwasher being properly filled with and maintaining a safe water level, two thermostats (mounted in the heater box behind the dress panel), float switch (mounted in the wash tank), and the heater relay (mounted in control box) with the heater being activated by the thermostats.

Once the dishwasher has been filled to the correct level, the heater should operate automatically. Should the tank heat be too high, too low or no indication of temperatures at all, the following checkout should be made.

Note: The following checkout should be made by either a qualified service person or electrician.

A- Checkout of the heater system

- 1- If the temperature is too high, adjust thermostat using instructions on the page entitled "Thermostats".
- 2- If temperature is too low, adjust thermostat as above, then:
 - a - Turn off power to machine by placing customer's circuit breaker in the "OFF" position. Turn off machine circuit breaker located on right side of control box.
 - b - Remove cover from control box on top of dishwasher.
 - c - Make sure water temperature is below 140° F.(preferably about 130°F.).
 - d - Turn on both circuit breakers. Observe heater relay (R1) while the power switch is turned "ON" and "OFF". If relay contacts move in and out, the heater relay is operating correctly: if not proceed to "C".

B- If heater relay (R1) closes:

- 1 - Check power supply at incoming terminal board L1, L2 & L3. It should be the same voltage as indicated on the machine data plate.
- 2 - Check power at connections on heater relay (R1). The voltage should agree with the voltage on the machine data plate. If not, check wires for breaks or bad connections.
- 3 - Check power at terminals of heater which should agree with the data plate. If not check wires for breaks or bad connections.
- 4 - Temperatures should rise as explained in "C-1", and amperage may be checked according to those instructions. Replace any defective elements.

C - If heater relay (R1) does not close.

- 1 - There is an insulated movable insulated movable bar on relay across the top. With an insulated probe, depress this bar and observe the thermometer: the temperature should rise noticeably in a minute or two. If it moves slowly, it would indicate that the element is faulty. If it moves constantly higher at a good rate, elements should be good.

Note: A check with an amp probe at heater relay (R1) terminals should be made to verify the amp draw on each leg. This should be appropriate for the voltage and phase indicated on the data plate

HEATER PROTECTION & AUTOMATIC FILL

This control is activated when the power switch is turned "ON". The primary function is to automatically energize the wash tank heat circuit. It will also cutoff the wash tank heat circuit should the water be accidently drained from the machine with the power switch still "ON". The power switch should always be turned-off before draining the unit.

This water level control consists of two (2) floats that operate when the power switch is turned on and works in conjunction with the thermostats and heater relays.

When the power switch is turned "ON" water starts to enter the dishmachine. When it reaches the proper level the normally open contacts in the water level float switch close activating the heating circuit for tank heat.

If the water level below the correct level while power is still on, the float switch will sense the lack of water and de-activate the heater.

SECTION 6: PARTS SECTION
THERMOSTATS/FRAME ASSEMBLY/DRESS PANELS

THERMOSTATS

The thermostat range is from 140°F to 240°F with a maximum bulb exposure temperature of 300°F.

Calibration:

Wash Thermostat:

Set Point: 165°F (Adjustable range)

Hi-Limit Thermostat:

Fixed set point: 210°F (Non-adjustable)

The hi-limit thermostat is used to protect the heater element in the event of a run away regulating thermostat or a dry fire situation. It is set for 210°F +0°F or -10°F with a fixed set point. **This part is not adjustable.**

The wash tank regulating thermostat will maintain the correct wash water temperature to meet NSF requirements. These specify that the wash be no lower than 160°F on hot water sanitizing machines.

To order the thermostats and corresponding decals:

Kit, Thermostat, Wash Regulating (CE Models)	06401-003-18-20
Kit, Thermostat, Wash Regulating (CS Models)	06401-003-18-21
Thermostat, High Limit Control	05930-011-49-43
1/4" Imperial Brass Fitting	05310-924-02-05

HEATER BOX COMPONENTS

Heater Box Weldment	05700-031-66-81
Heater Box Cover	05700-031-66-82
Terminal Board	05940-002-78-97

FRAME WELDMENTS

<u>Model</u>	<u>Left to Right Part Number</u>	<u>Right to Left Part Number</u>
AJ-54's	05700-031-75-20	05700-031-75-20
AJ-54CGP	05700-002-65-68	05700-002-65-68
AJ-76's	05700-031-75-25	05700-031-75-22
AJ-76CGP	05700-031-75-25	N/A
AJ-90's	05700-031-75-26	05700-031-75-24

Bullet Feet (4 per model) - order using part number 5340-011-71-74.

FRONT DRESS PANELS

<u>Model</u>	<u>Left to Right Part Number</u>	<u>Right to Left Part Number</u>
AJ-54's	05700-031-72-22	05700-031-72-22
AJ-54CGP	05700-002-63-12	05700-002-63-12
AJ-76's	05700-031-71-85	05700-031-72-42
AJ-76CGP	05700-002-89-68	N/A
AJ-90's	05700-031-74-06	05700-031-77-10

SECTION 6: PARTS SECTION
PREWASH PLUMBING ASSEMBLY

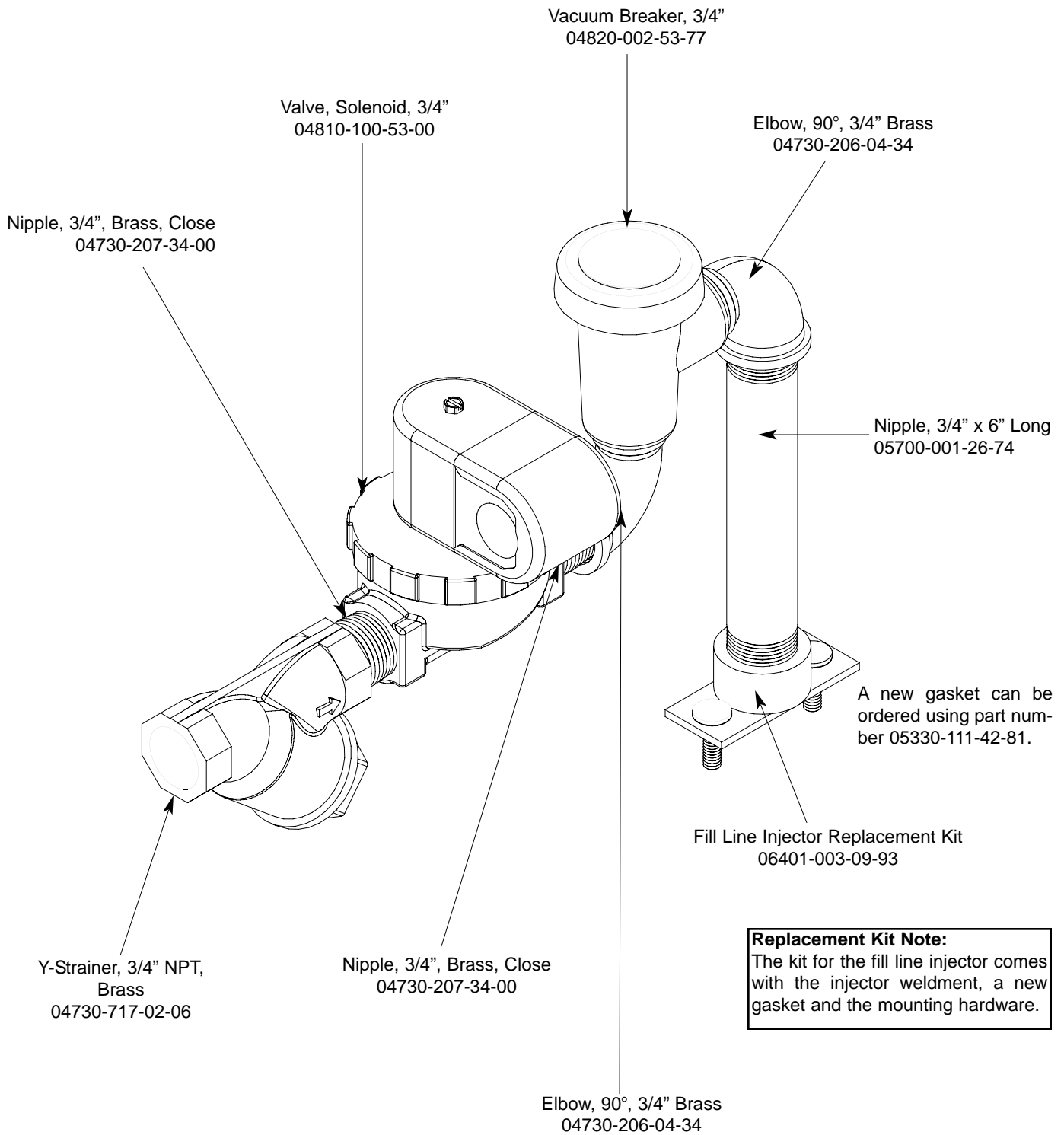

SECTION 6: PARTS SECTION
WASH SECTION INCOMING PLUMBING ASSEMBLY

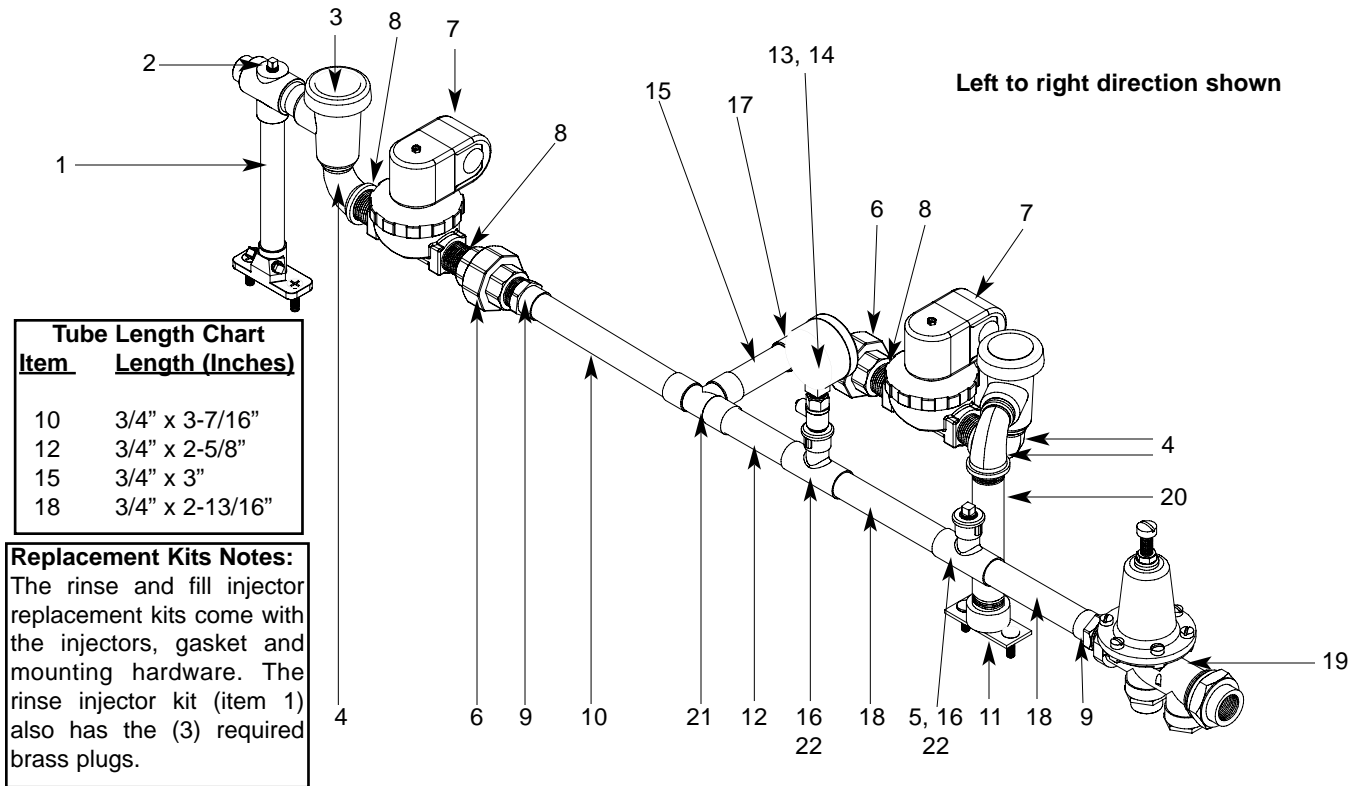

ITEM	QTY	DESCRIPTION	Mfg. No.
1	1	Rinse Injector Replacement Kit	06401-003-11-88
	1	Gasket	05330-111-42-81
2	3	Plug, Brass, 1/8" NPT	04730-209-07-37
3	2	Vacuum Breaker, 3/4" NPT	04820-002-53-77
4	3	Elbow, Street, 3/4" NPT	04730-206-04-34
5	1	Plug	04730-209-01-00
6	2	Union, Brass, 3/4"	04730-212-05-00
7	2	Solenoid Valve, 3/4"	04810-100-53-00
8	4	Nipple, Close, Brass, 3/4" NPT	04730-207-34-00
9	2	Fitting, 3/4" Male to Slip Copper	04730-401-11-01
10	1	Tube, Copper	See Chart
11	1	Fill Injector Replacement Kit	06401-003-09-93
	1	Gasket	05330-111-42-81
12	1	Tube, Copper	See Chart
13	1	Gauge, Pressure, 0-100 PSI	06685-111-88-34
	1	Decal, 15-25 PSI	09905-002-97-74
14	1	Valve, Ball, Test Cock, 1/4" NPT	04810-011-72-67
15	1	Tube, Copper	See Chart
16	2	Tee, 3/4" x 3/4" x 1/2"	04730-411-03-01
17	1	Elbow, Brass, 90°, 3/4" Copper	04730-406-42-01
18	2	Tube, Copper	See Chart
19	1	Regulator, Pressure, 3/4" NPT, Brass	06685-011-58-22
20	1	Nipple, Brass, 6" Long	05700-001-26-74
21	1	Tee, 3/4", CUB x CUB x CUB	04730-
411-46-01			
22	2	Fitting, Adapter, 1/2" to 1/4"	04730-401-41-01

SECTION 6: PARTS SECTION

EXTERNAL ELECTRIC BOOSTER INCOMING PLUMBING ASSEMBLIES

Plumbing with Water Hammer Arrestor

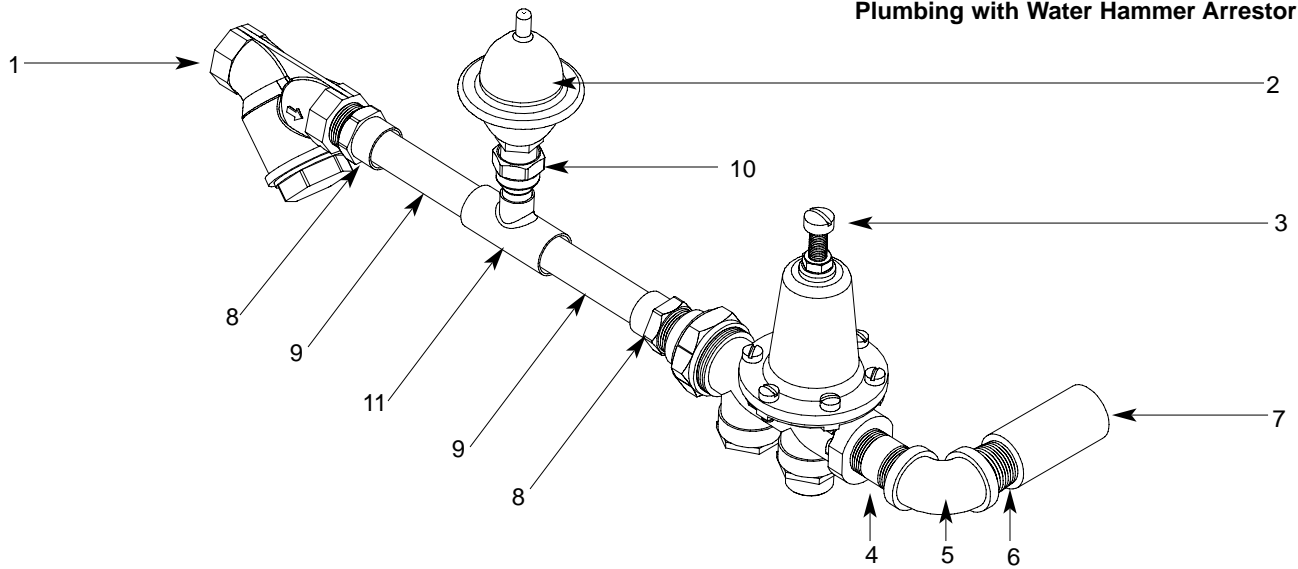

Plumbing without Water Hammer Arrestor

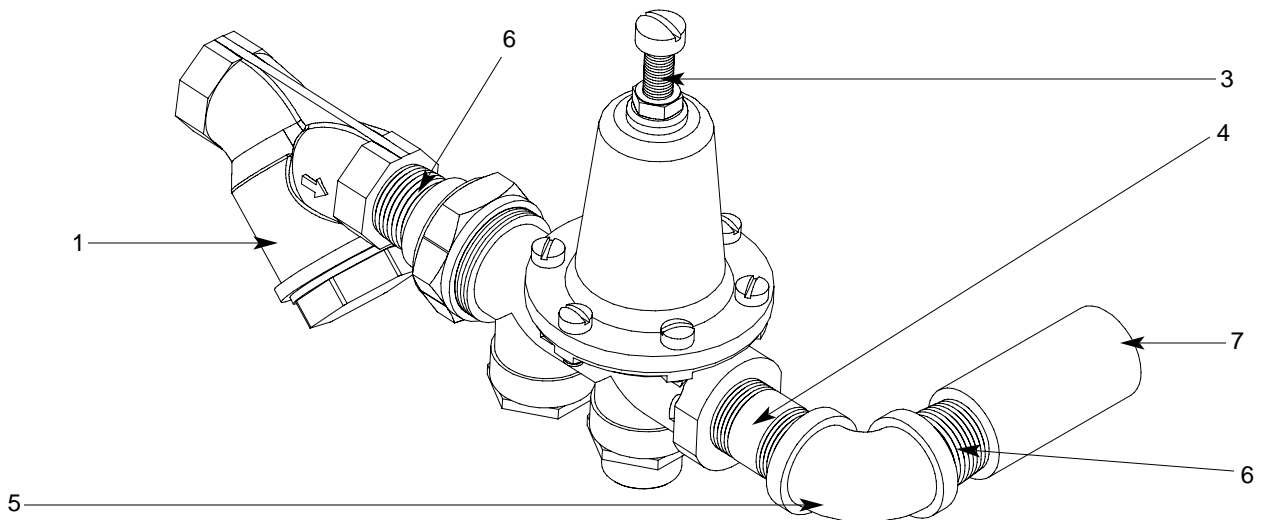

ITEM	QTY	DESCRIPTION	Mfg. No.
1	-	Y-Strainer, 3/4" NPT, Brass	04730-717-02-06
2	-	Arrestor, Water Hammer, 1/2" NPT	06685-100-05-00
3	-	Regulator, Pressure, 3/4" NPT, Brass	06685-011-58-22
4	-	Nipple, 3/4" NPT x 2" Long, Brass	04730-207-46-00
5	-	Elbow, Brass, 90°, 3/4"	04730-206-13-00
6	-	Nipple, 3/4" NPT, Close, Brass	04730-207-34-00
7	-	Coupling, 3/4" FNPT x 3/4" FNPT, Brass	04730-011-87-95
8	-	Adapter, 3/4" Male	04730-401-11-01
9	-	Tube, Copper, 3/4" x 3-7/16" Long	05700-011-72-70
10	-	Adapter, 1/2" NPT x Male	04730-401-07-01
11	-	Tee, Copper, 3/4" x 3/4" x 1/2"	04730-411-03-01

SECTION 6: PARTS SECTION
EXTERNAL ELECTRIC BOOSTER OPTION OUTLET PLUMBING

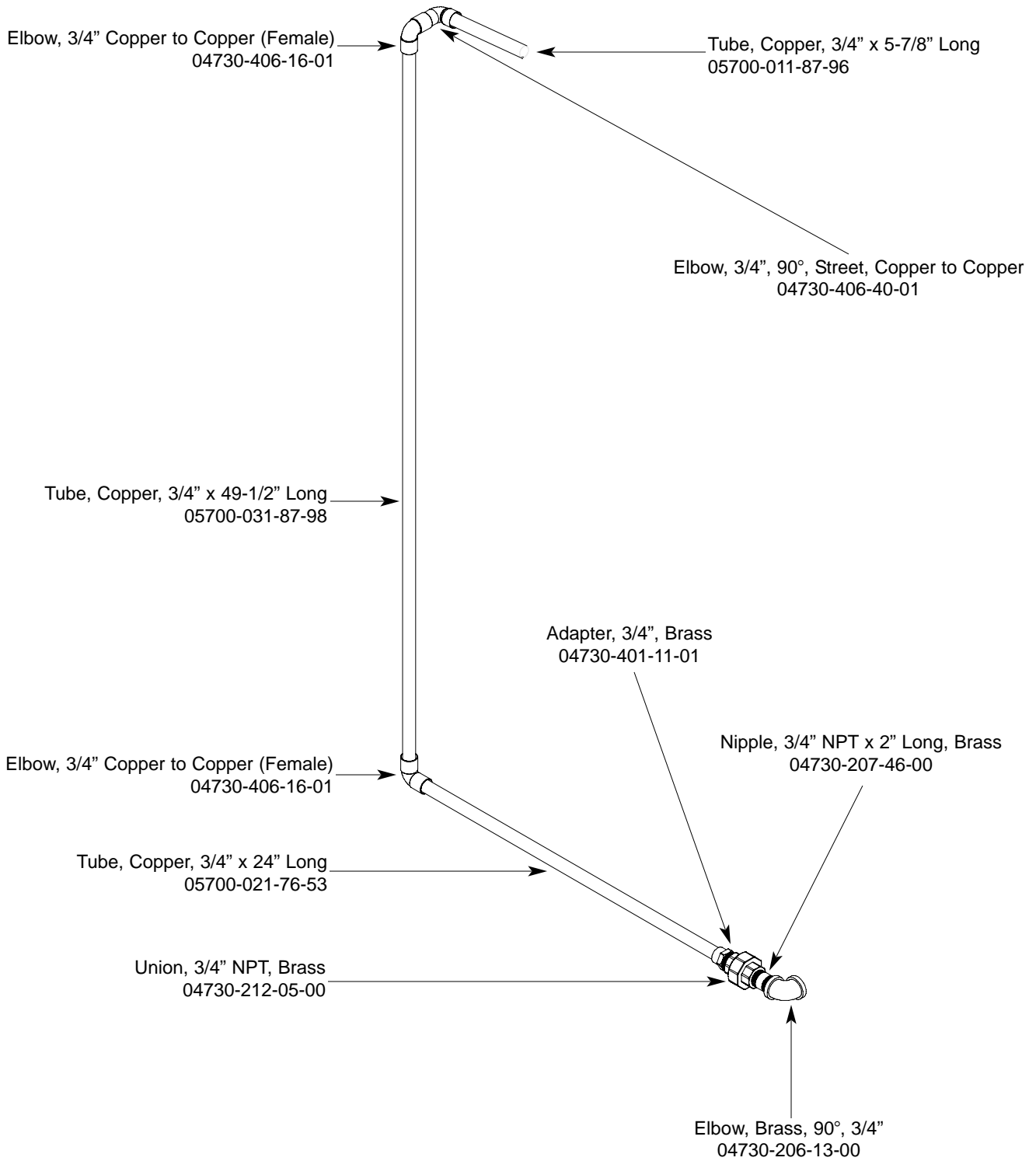

SECTION 6: PARTS SECTION

WATER HAMMER ARRESTOR OPTION/WATER PRESSURE REGULATOR KIT OPTION

WATER HAMMER ARRESTOR OPTION

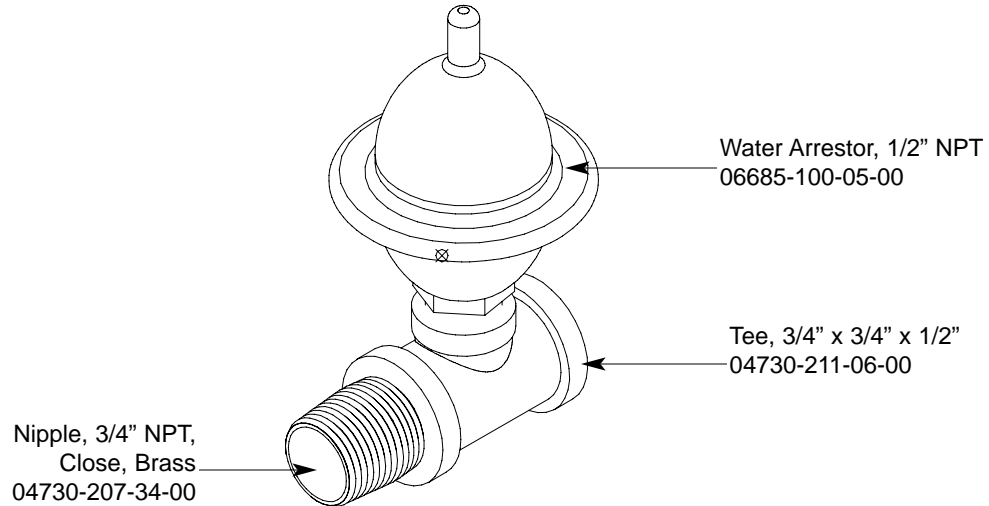

WATER PRESSURE REGULATOR WITH ARRESTOR KIT OPTION

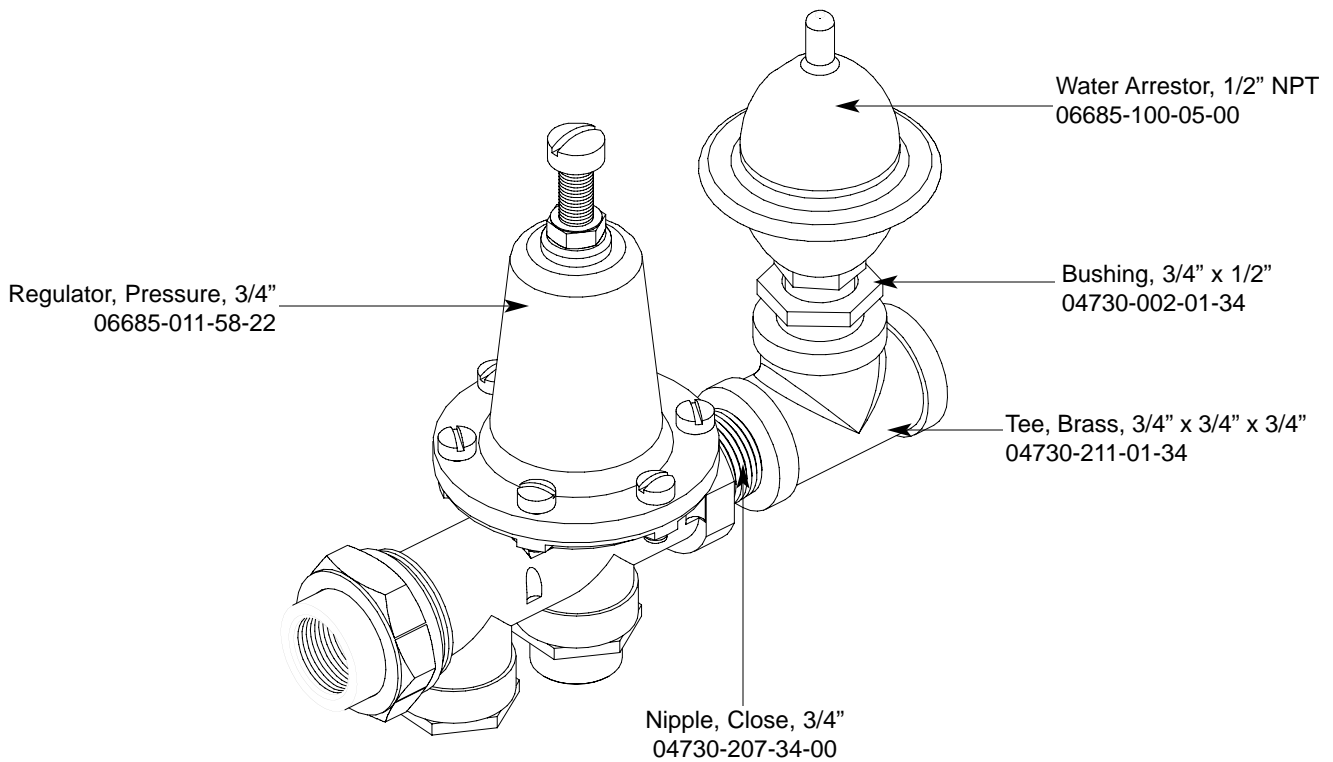

SECTION 6: PARTS SECTION

RINSE SOLENOID VALVE & VACUUM BREAKER REPAIR PARTS KITS

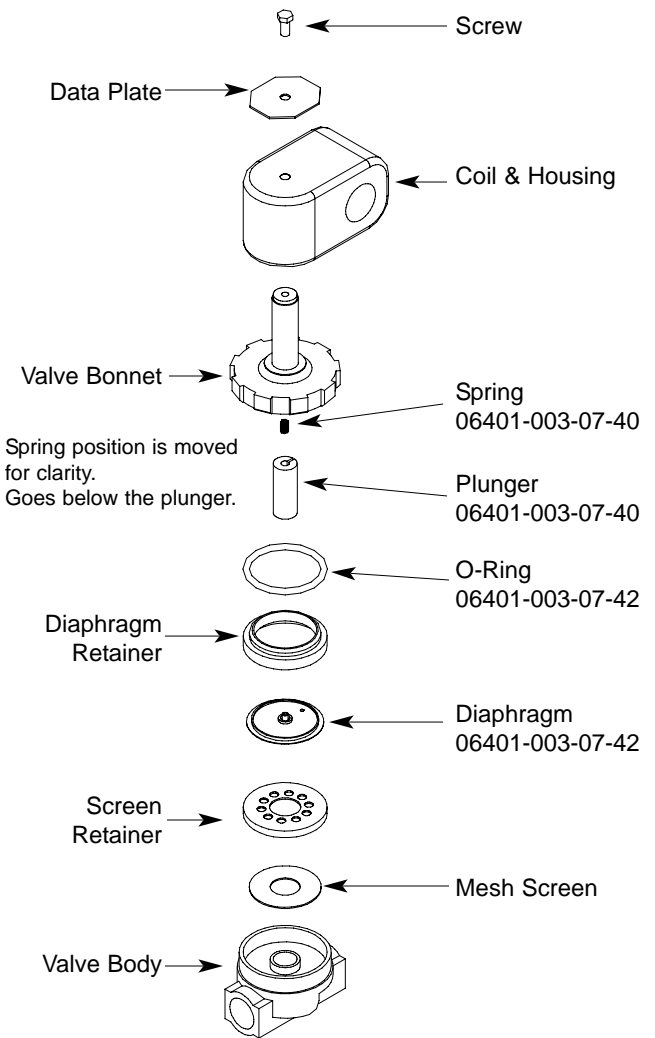

Complete 110 Volt Solenoid Valve Assembly, 3/4"
04810-100-53-00

Coil & Housing only, 3/4"
06401-003-07-43

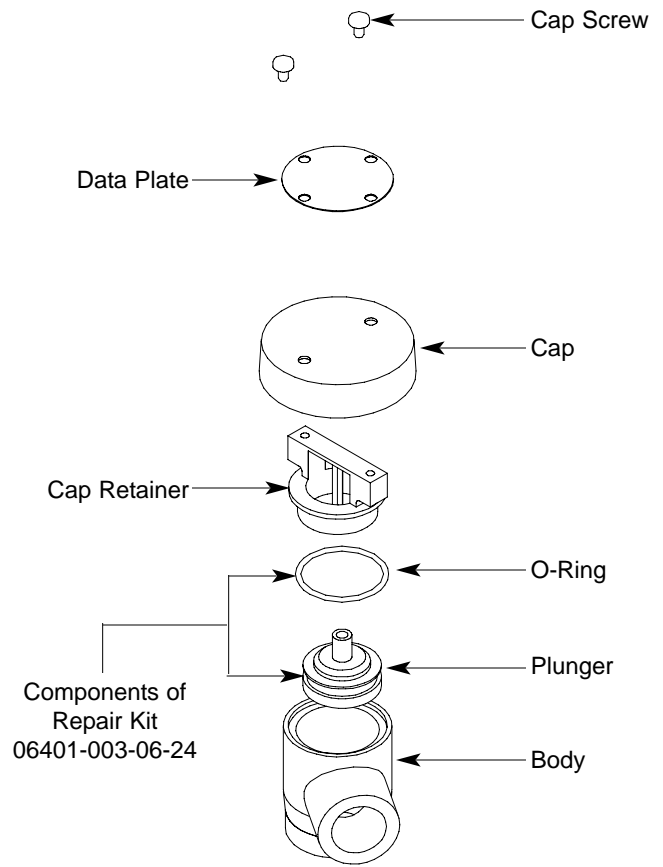

Complete Vacuum Breaker Assembly, 3/4" NPT
04820-002-53-77

SECTION 6: PARTS SECTION
STEAM UNIT WASH TANK COIL ASSEMBLY

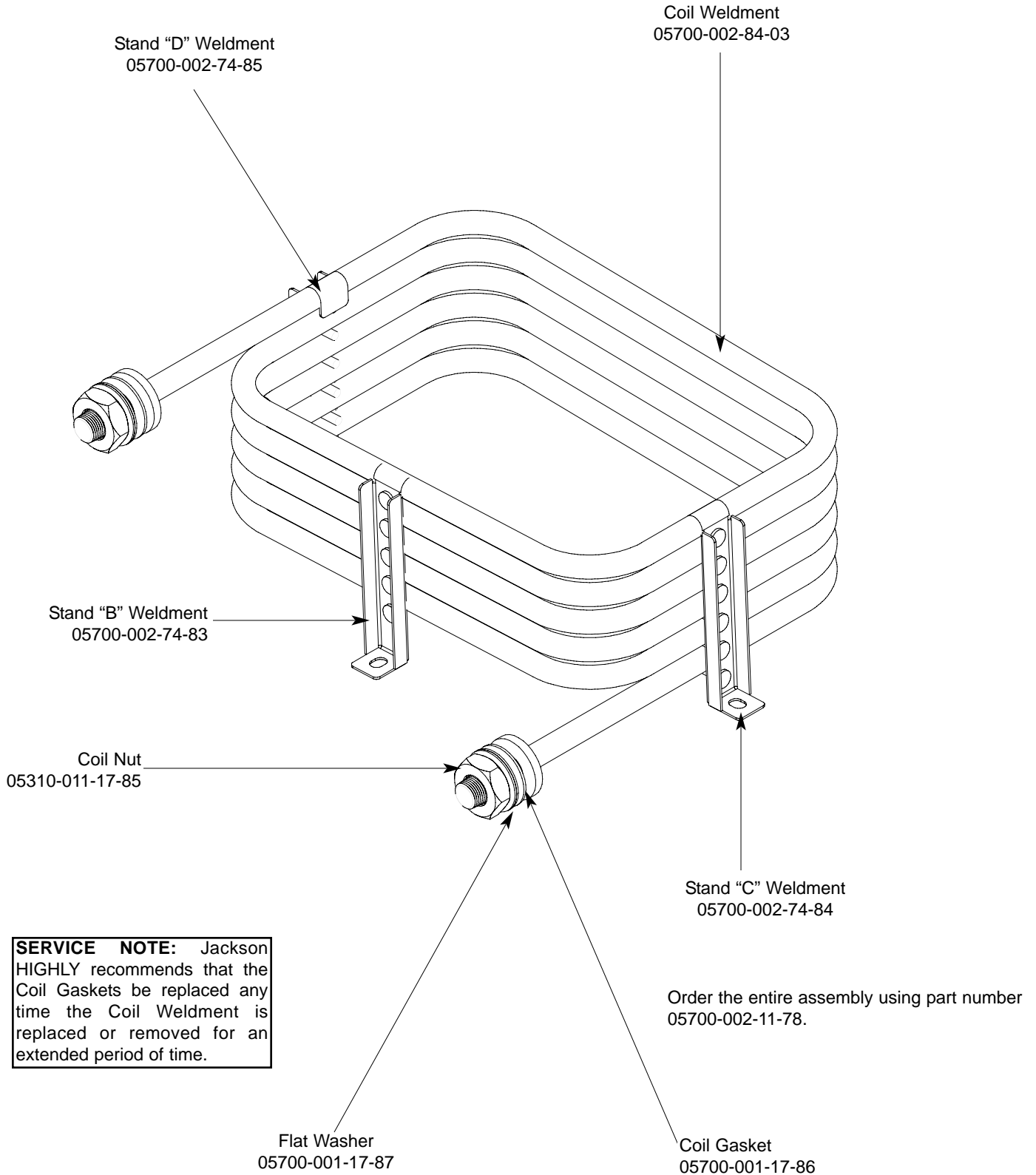

SECTION 6: PARTS SECTION

STEAM PLUMBING (LEFT TO RIGHT)

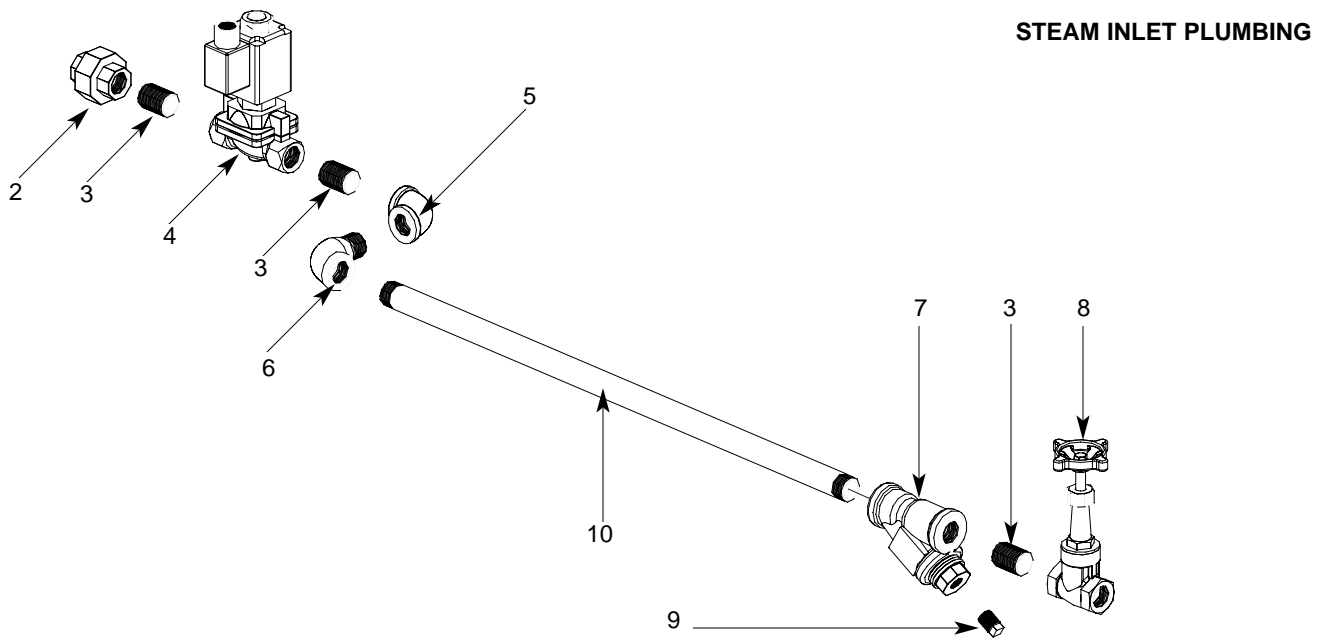

STEAM INLET PLUMBING

ITEM	QTY	DESCRIPTION	Mfg. No.
1	1	Reducer, 3/4" NPT to 1/2" NPT, Black Iron	04730-911-02-34
2	2	Union, 3/4" NPT, Black Iron	04730-912-01-00
3	4	Nipple, Close, 3/4" NPT, Black Iron	04730-907-01-00
4	1	Valve, Steam Solenoid, 3/4" NPT, 120V	04820-011-87-39
5	2	Elbow, 90°, 3/4" FNPT, Black Iron	04730-906-10-34
6	2	Elbow, Street, 90°, 3/4" NPT, Black Iron	04730-011-87-37
7	1	Y-Strainer, 3/4" NPT, Black Iron	04730-217-01-32
8	1	Valve, Gate, Steam, 3/4" NPT	04820-100-19-00
9	1	Plug, 3/8" NPT, Black Iron	04730-909-02-34
10	1	Nipple, 3/4" NPT x 47" Long	04730-021-89-26
11	1	Pipe, 3/4" NPT x 2" Long, Black Iron	04730-907-05-34
12	1	Steam Trap, 3/4" NPT	06680-500-02-77

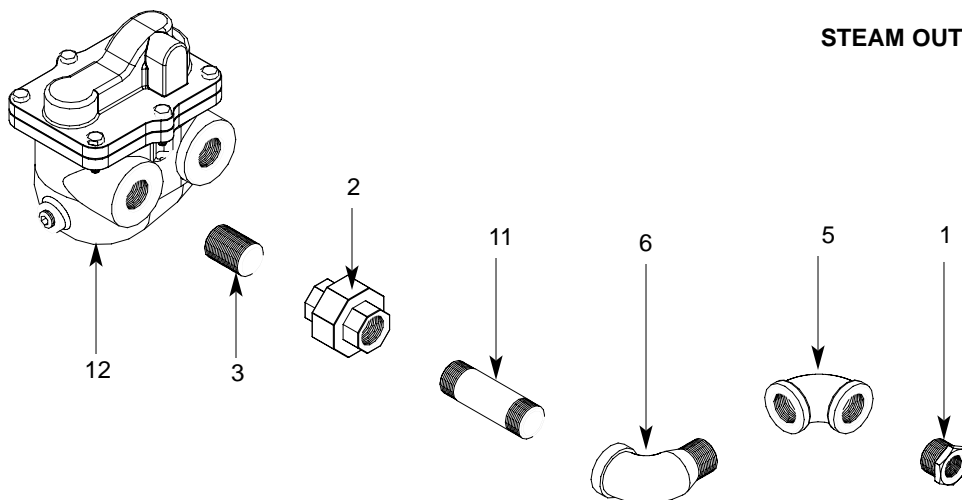

STEAM OUTLET PLUMBING

SECTION 6: PARTS SECTION
STEAM PLUMBING (RIGHT TO LEFT)

STEAM INLET PLUMBING

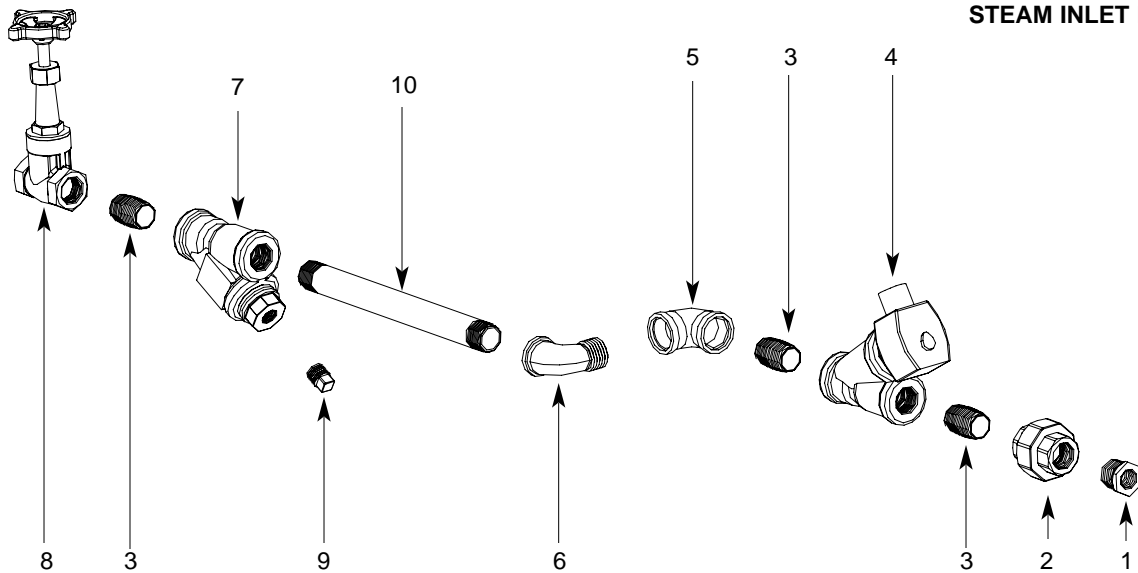

ITEM	QTY	DESCRIPTION	Mfg. No.
1	2	Reducer, 3/4" NPT to 1/2" NPT, Black Iron	04730-911-02-34
2	2	Union, 3/4" NPT, Black Iron	04730-912-01-00
3	4	Nipple, Close, 3/4" NPT, Black Iron	04730-907-01-00
4	1	Valve, Steam Solenoid, 3/4" NPT, 120V	04820-011-87-39
5	1	Elbow, 90°, 3/4" FNPT, Black Iron	04730-906-10-34
6	1	Elbow, Street, 90°, 3/4" NPT, Black Iron	04730-011-87-37
7	1	Y-Strainer, 3/4" NPT, Black Iron	04730-217-01-32
8	1	Valve, Gate, Steam, 3/4" NPT	04820-100-19-00
9	1	Plug, 3/8" NPT, Black Iron	04730-909-02-34
10	1	Nipple, 3/4" NPT x 10" Long	04730-907-06-34
11	1	Reducer, 3/4" NPT to 1/2" NPT, Black Iron	04730-911-02-34
12	1	Elbow, 90°, 3/4" FNPT, Black Iron	04730-906-10-34
13	1	Elbow, Street, 3/4" NPT, Black Iron	04730-011-87-37
14	1	Steam Trap, 3/4" NPT	06680-500-02-77

STEAM OUTLET PLUMBING

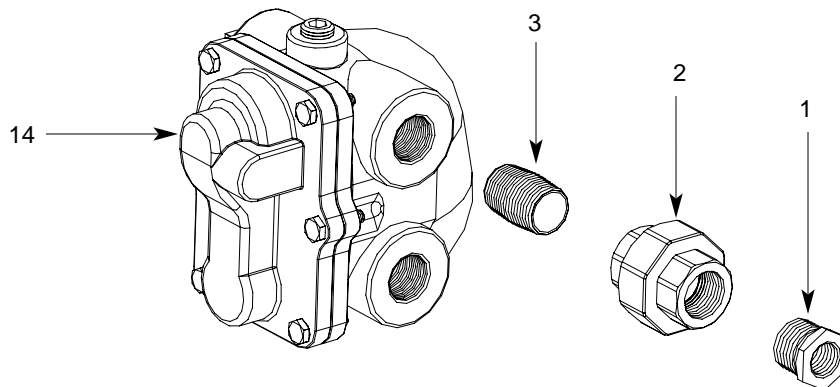

SECTION 6: PARTS SECTION
GAS COIL ASSEMBLY (CGP MODELS)

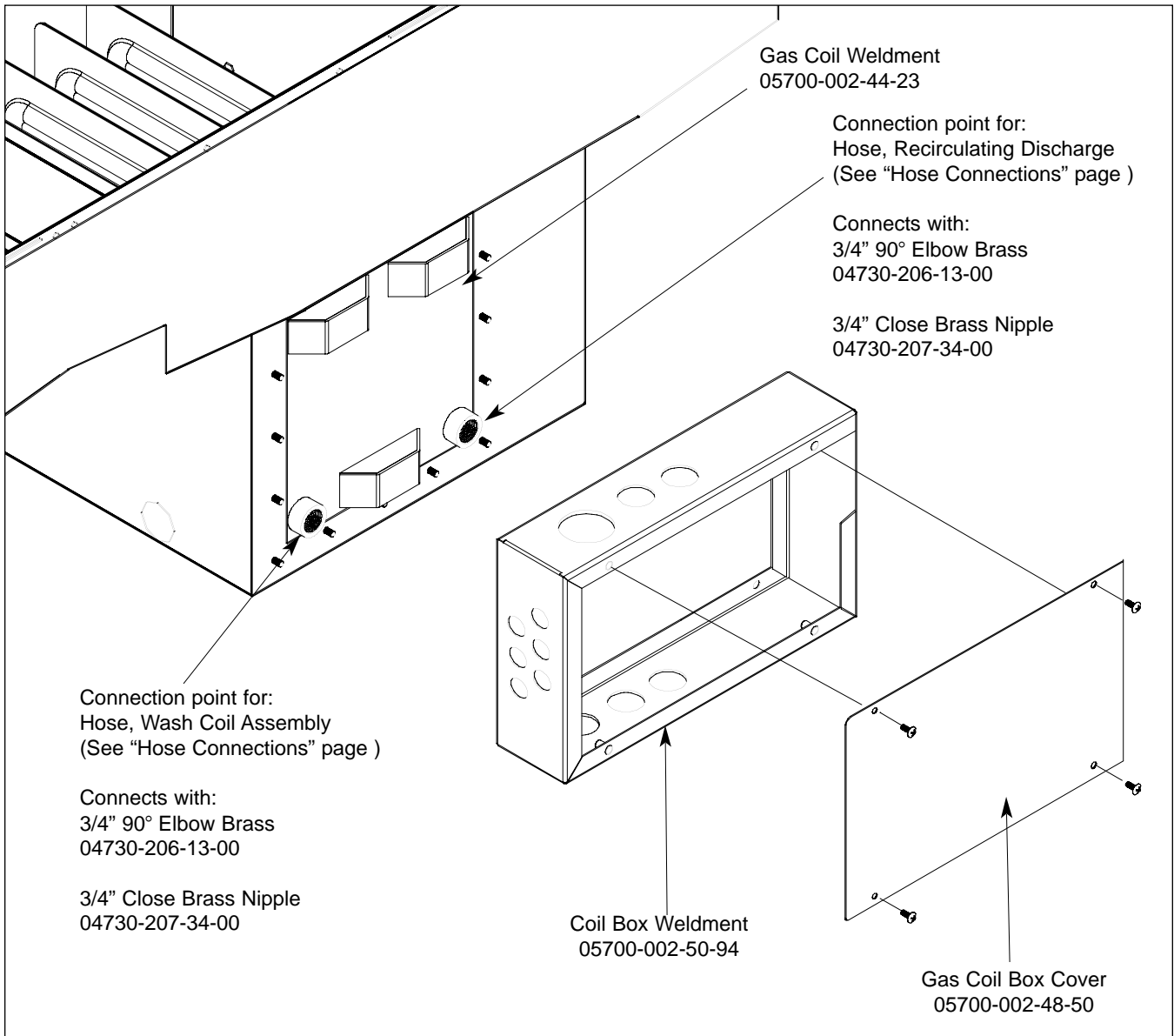

Other items used but not shown.

ITEM	QTY	DESCRIPTION	Mfg. No.
1	1	Thermostat, High Limit	05930-011-49-43
2	1	Gasket	05330-200-02-70
3	1	Terminal Board	05940-002-78-97
4	1	Thermostat Bracket	05700-011-81-64
5	1	Decal, Thermostat Regulating	09905-011-84-31
6	1	Thermostat, Wash Regulating	06401-140-00-32
7	2	Fitting, 1/4", Imperial Brass	05310-924-02-05

SECTION 6: PARTS SECTION
TANK, RINSE BOOSTER (CGP MODELS ONLY)

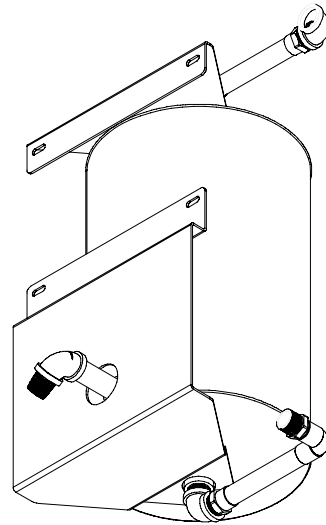
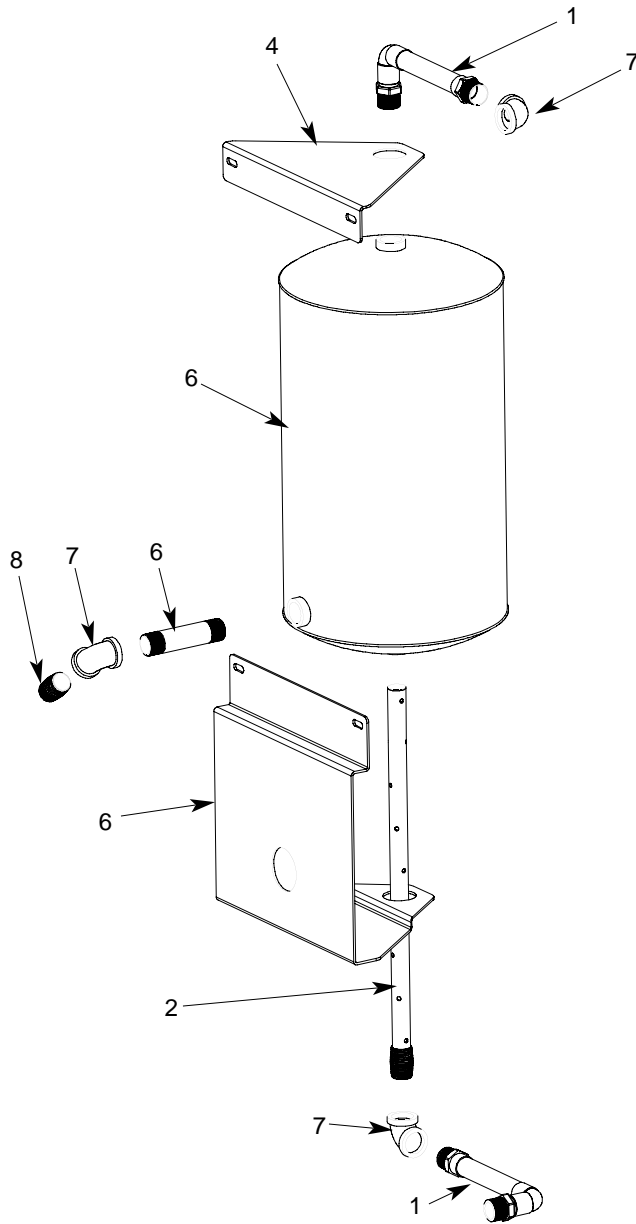

BOTTOM ANGLED VIEW

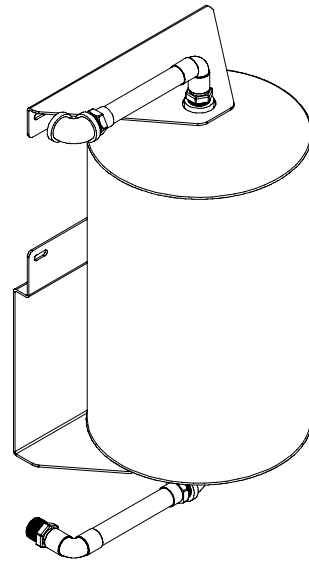

TOP ANGLED VIEW

ITEM	QTY	DESCRIPTION	Mfg. No.
1	2	Plumbing Assembly, Inlet/Discharge, Rinse Tank	05700-002-51-24
2	1	Tube, Dispersion Weldment	05700-002-46-16
3	1	Tank, GP Rinse	05700-002-45-05
4	1	Bracket, Upper Rinse Tank	05700-002-67-13
5	1	Bracket, Lower Rinse Tank	05700-002-67-14
6	1	Nipple, 3/4" NPT x 4" Long	04730-207-05-00
7	3	Elbow, 3/4" NPT, 90° Brass	04730-206-13-00
8	1	Nipple, 3/4" NPT x Closed Brass	04730-207-34-00

SECTION 6: PARTS SECTION
RECIRCULATING PUMP ASSEMBLY (CGP MODELS ONLY)

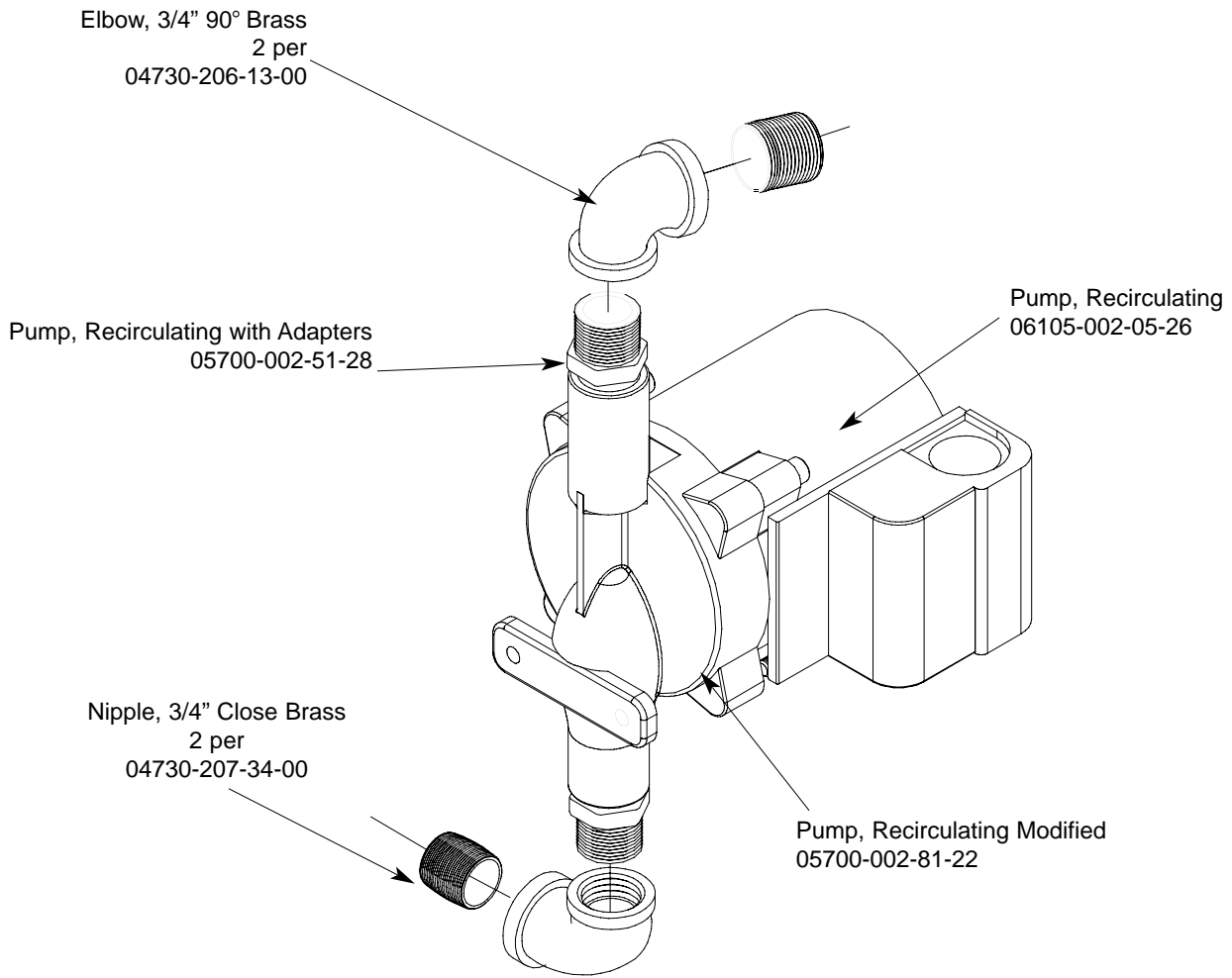

Used on AJ-54CGP, AJ-76CGP, AJ-90CGP units right to left units and the AJ-54CGP left to right unit.

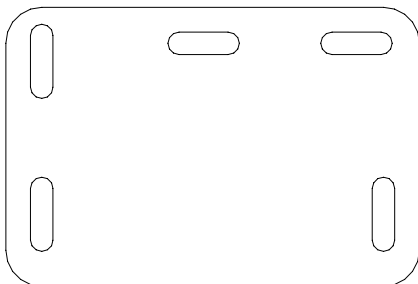

Mounting Bracket
05700-002-25-74

Used only on AJ-76CGP left to right units.

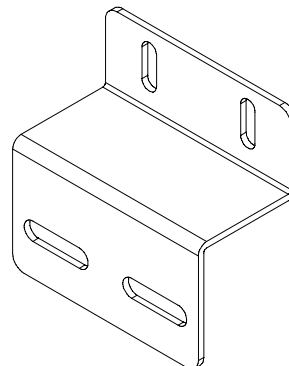

Mounting Bracket
05700-002-23-61

SECTION 6: PARTS SECTION
HOSE CONNECTIONS (CGP MODELS ONLY)

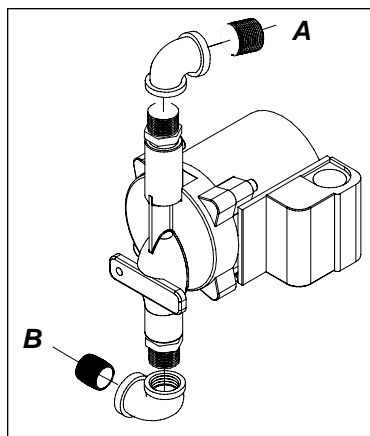

Recirculating Pump Assembly

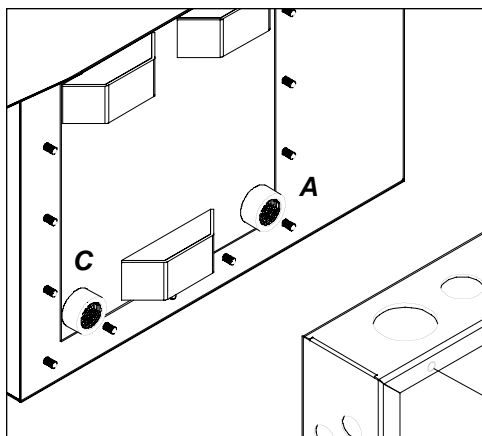

Gas Coil Weldment

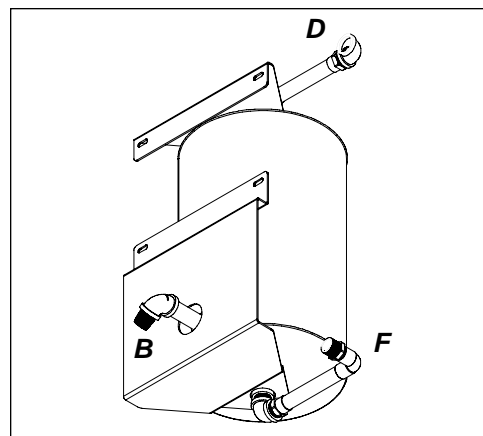

Rinse Booster Tank

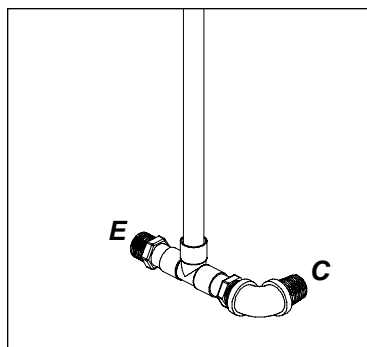

Rinse Header Plumbing Assembly

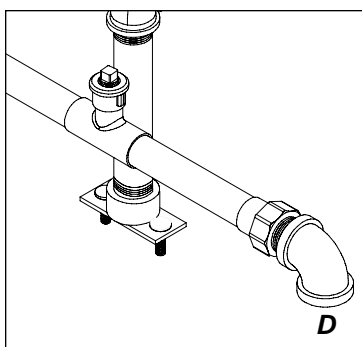

Wash/Fill Plumbing Assembly

HOSE ASSEMBLIES

AJ-54CGP (L-R & R-L)

AJ-76CGP (L-R)

*Each hose assembly includes 2, 3/4" Pushlock Fittings part number 04730-011-94-00.

A - Hose, Recirculating Discharge	(39") 05700-002-65-58	(31") 05700-002-89-69
B - Hose, Recirculating Pump Suction	(23 1/2") 05700-002-65-57	(18") 05700-002-51-38
C - Hose, Wash Coil Assembly	(34") 05700-002-52-76	(36") 05700-002-89-72
D - Hose, Wash/Fill Supply	(60") 05700-003-03-97	(60") 05700-003-03-97

E - Hose connection to existing gas booster outlet fitting.

F - Hose connection to existing gas booster inlet fitting.

Gas Booster Connection Kit 05700-002-51-73 includes:

18 Feet of 3/4" Hose

4 - 3/4" Push Lock Fittings

SECTION 6: PARTS SECTION
WASH/FILL PLUMBING ASSEMBLY (CGP MODELS)

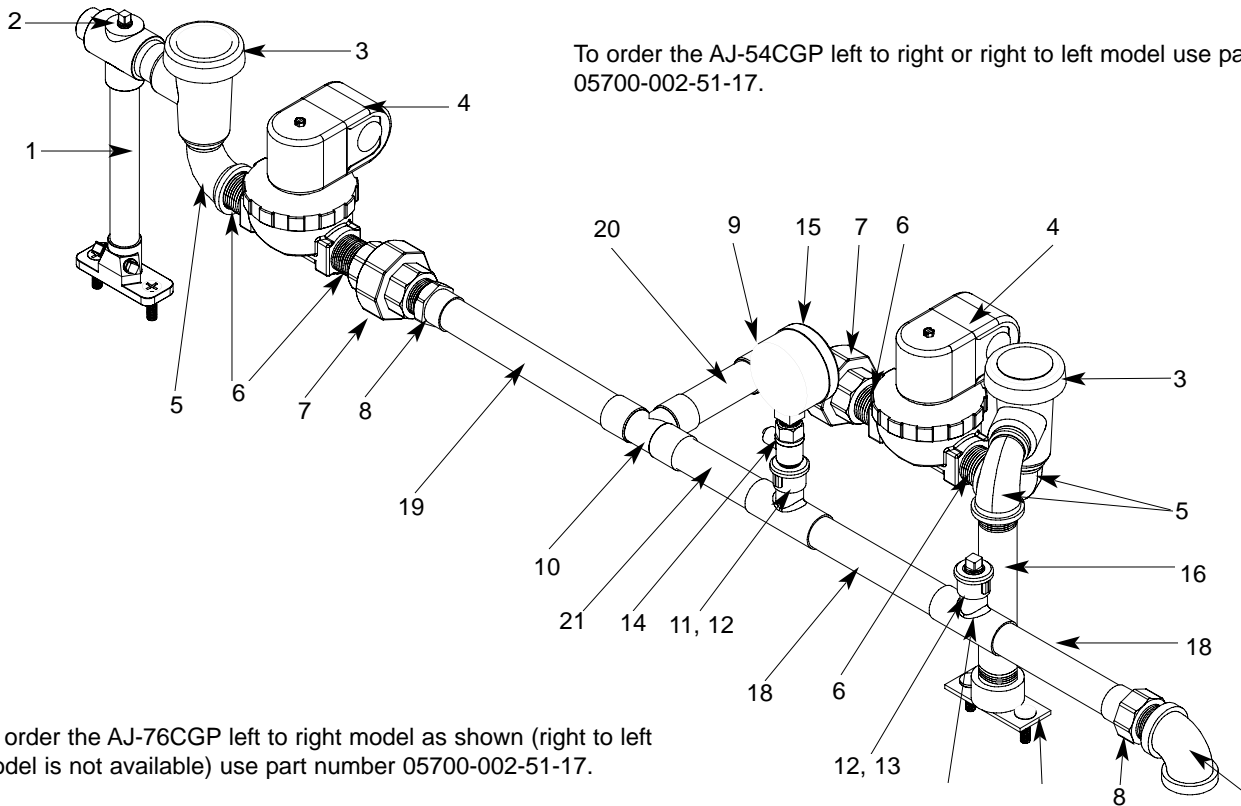

To order the AJ-76CGP left to right model as shown (right to left model is not available) use part number 05700-002-51-17.

ITEM	QTY	DESCRIPTION	Mfg. No.
1	1	Rinse Injector Weldment	05700-002-57-87
	1	Gasket	05330-111-42-81
2	3	Plug, 1/8" NPT, Brass	04730-209-07-37
3	2	Vacuum Breaker, 3/4" NPT	04820-002-53-77
4	2	Valve, Solenoid, 3/4" NPT, 110 Volt	04810-100-53-00
5	3	Elbow, 3/4" Street Brass	04730-206-04-34
6	4	Nipple, Close, Brass, 3/4" NPT	04730-207-34-00
7	4	Union, 3/4", Copper to Copper	04730-212-05-00
8	2	Adapter, 3/4" Fitting x Male	04730-401-11-01
9	1	Elbow, 90° 3/4" Copper to MSPS	04730-406-42-01
10	1	Tee, 3/4", CUB x CUB x CUB	04730-411-46-01
11	2	Tee, 3/4" x 3/4" x 1/2"	04730-411-03-01
12	2	Fitting, Adapter, 1/2" to 1/4"	04730-401-41-01
13	1	Plug, 1/4" NPT, Brass	04730-209-01-00
14	1	Test Cock, Valve, Ball, 1/4" NPT	04810-011-72-67
15	1	Gauge, Pressure, 0-100 PSI	06685-111-88-34
	1	Decal, 15-25 PSI	09905-002-97-74
16	1	Nipple, Brass, 6" Long	05700-001-26-74
17	1	Fill Injector	05700-011-67-99
	1	Gasket	05330-111-42-81
18	1	Tube, Copper, 3/4" x 2 13/16" Long	05700-011-72-72
19	1	Tube, Copper, 3/4" x 3 7/16" Long	05700-011-72-70
20	1	Tube, Copper, 3/4" X 3" Long	05700-000-54-85
21	1	Tube, Copper, 3/4" x 2 5/8" Long	05700-011-72-71
22	1	Elbow, 3/4" NPT, 90° Brass	04730-206-13-00

SECTION 6: PARTS SECTION
RINSE HEADER PLUMBING ASSEMBLY (CGP MODELS)

Complete Plumbing Assembly
05700-002-51-16

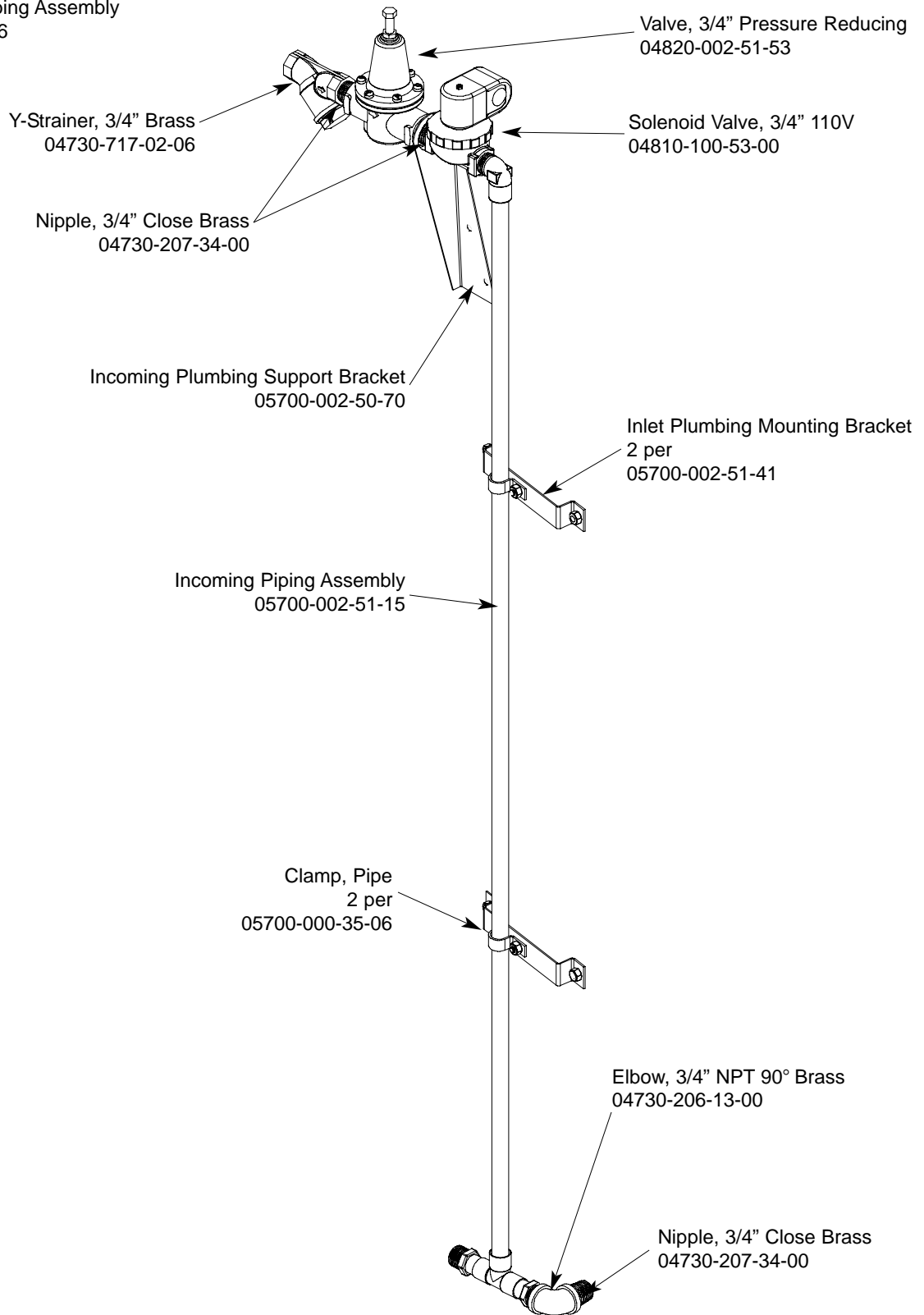

SECTION 6: PARTS SECTION
AJ-54 SERIES DRAIN PLUMBING ASSEMBLIES

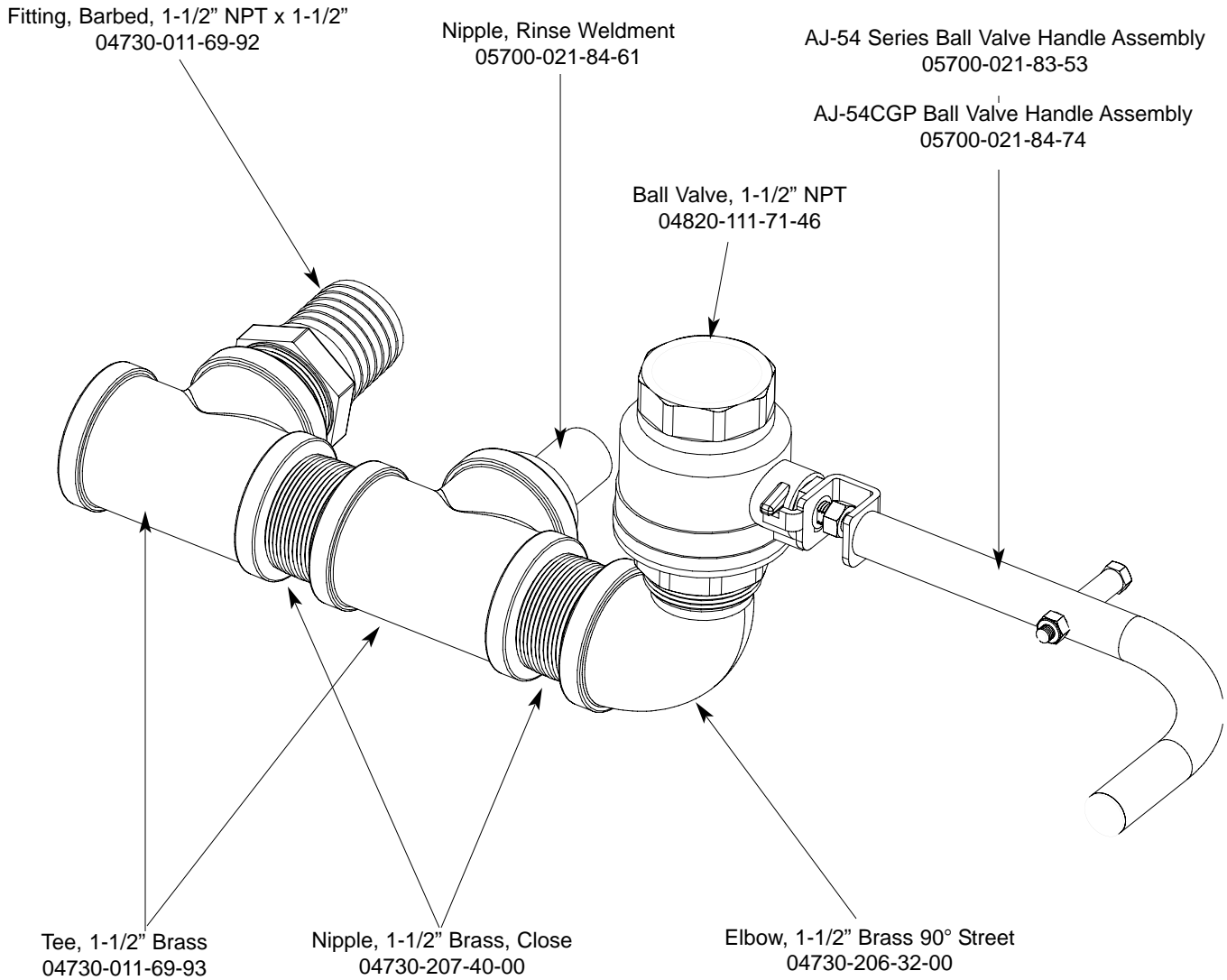

AJ-54 Series Complete Drain Assembly
05700-031-70-10

AJ-54CGP Complete Drain Assembly
05700-002-52-71

SECTION 6: PARTS SECTION

AJ-76 DRAIN PLUMBING ASSEMBLIES

Left to Right Plumbing Assembly

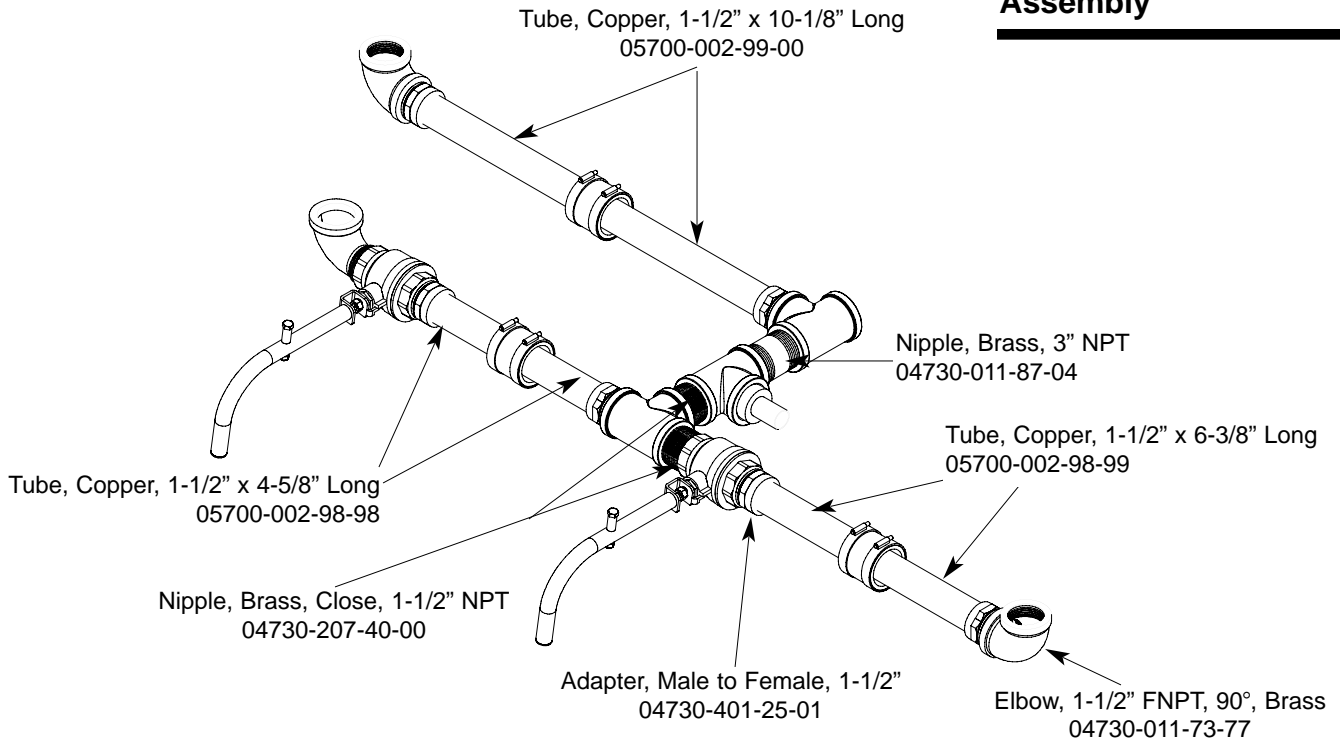

All parts are common to both assemblies.

Right to Left Plumbing Assembly

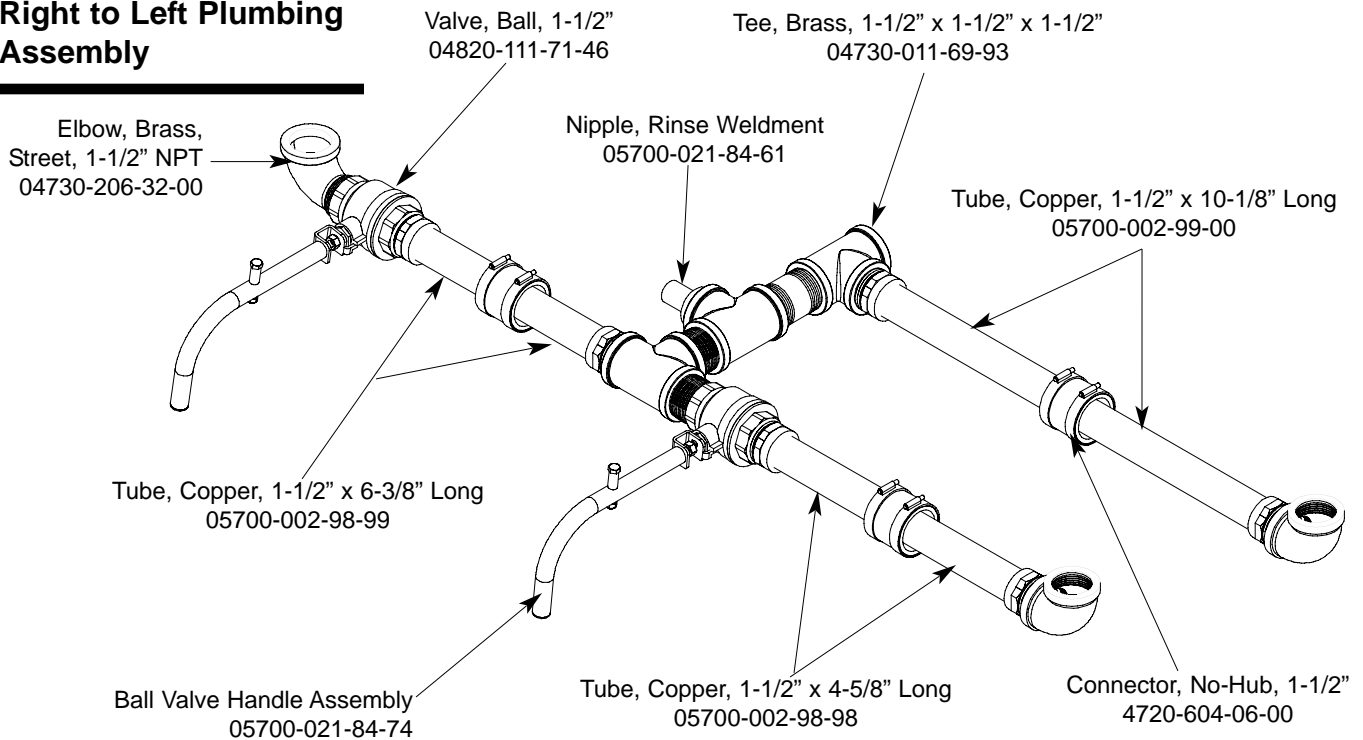

SECTION 6: PARTS SECTION

AJ-90 DRAIN PLUMBING ASSEMBLIES

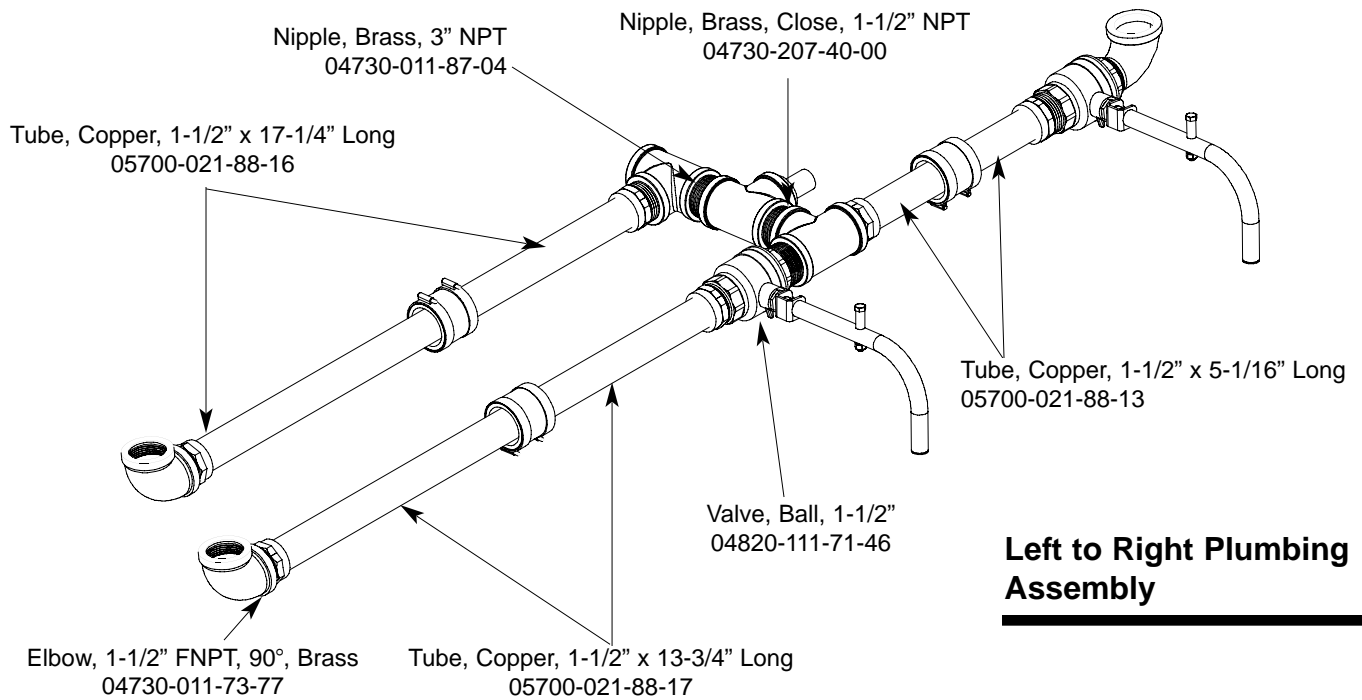

All parts are common to both assemblies.

Right to Left Plumbing Assembly

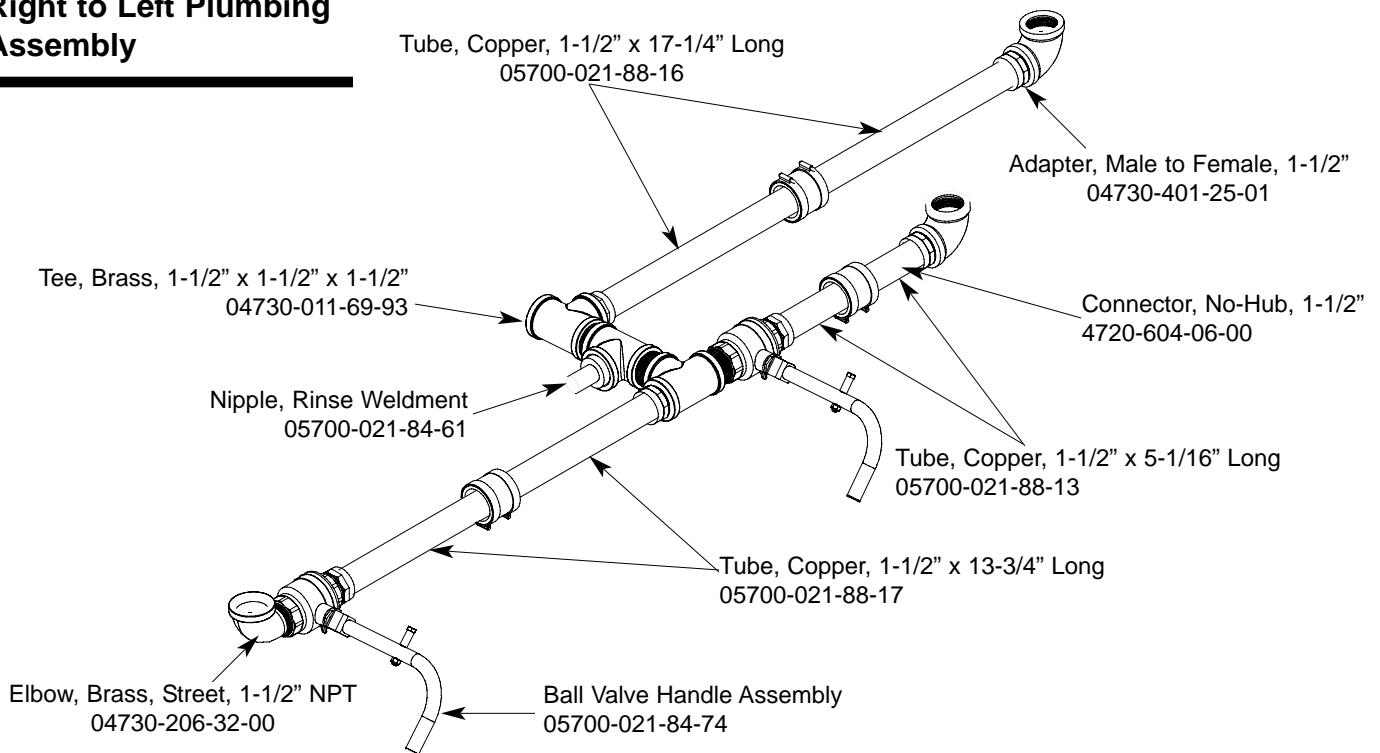

SECTION 6: PARTS SECTION

AJ-76CGP (LEFT TO RIGHT) DRAIN PLUMBING ASSEMBLY

(Right to left model not available.)

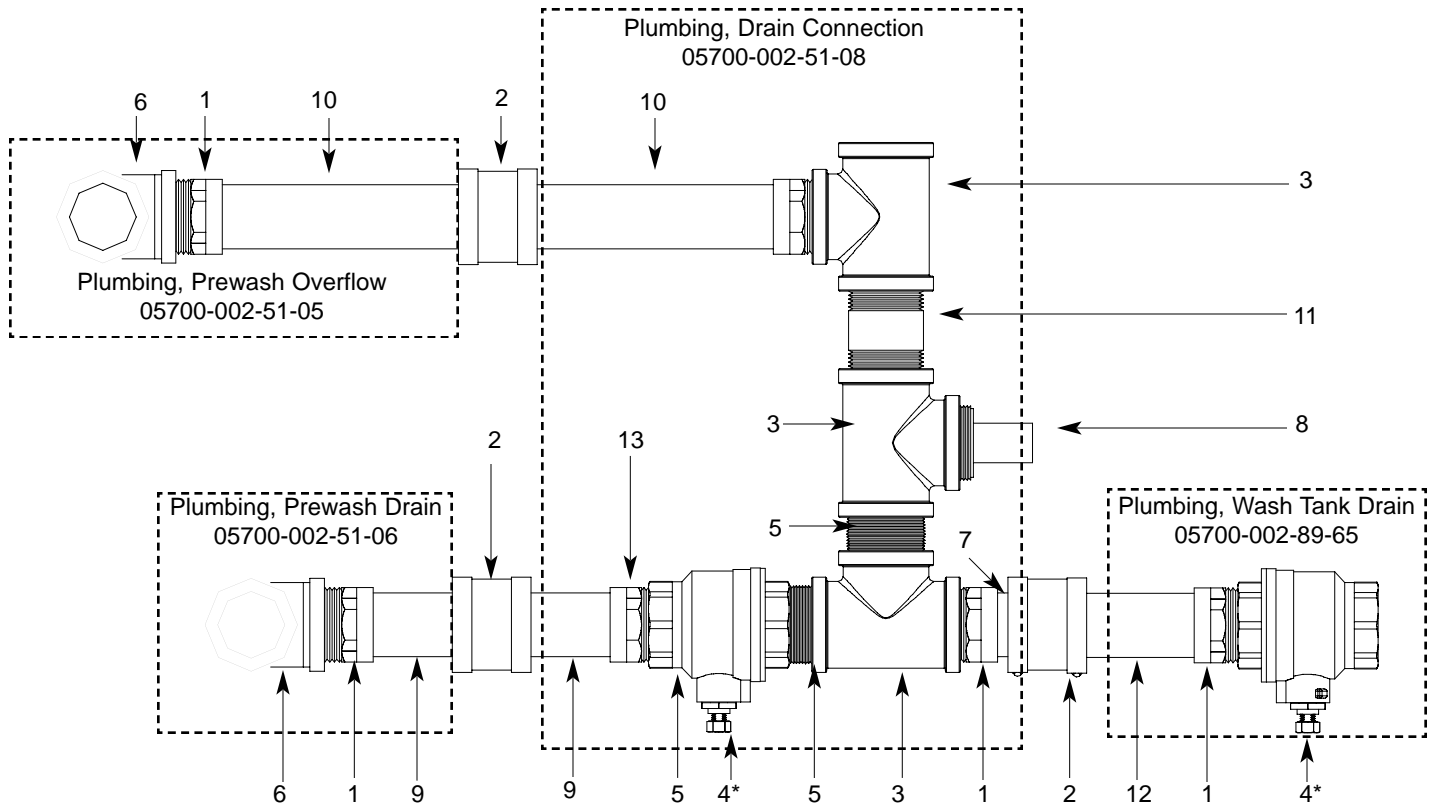

ITEM	QTY	DESCRIPTION	Mfg. No.
1	6	Adapter, Male to Female, 1-1/2"	04730-401-25-01
2	3	No-Hub Connector	4720-604-06-00
3	3	Tee, Brass, 1-1/2" FNPT	04730-011-69-93
4	2	Ball Valve, 1-1/2" FNPT	04820-011-71-46
*	2	Valve Handle Weldment Assembly (Not Shown)	05700-021-84-74
5	2	Nipple, Brass, Close, 1-1/2" NPT	04730-207-40-00
6	2	Elbow, Brass, 90°, 1-1/2" FNPT	04730-011-73-77
7	1	Tube, Copper, 1-1/2" x 1-3/4" Long	05700-000-75-57
8	1	Rinse Nipple Weldment	05700-021-84-61
9	2	Tube, Copper, 1-1/2" x 3-1/2" Long	05700-011-84-23
10	2	Tube, Copper, 1-1/2" x 7-1/2" Long	05700-002-50-98
11	1	Nipple, Brass, 1-1/2" NPT x 3" Long	04730-011-87-04
12	1	Tube, Copper, 1-1/2" x 4-1/4" Long	05700-011-88-40
1	1	Entire Assembly	05700-002-89-64

SECTION 6: PARTS SECTION
DRAIN QUENCH SYSTEM

Drain Quench Assembly
06401-002-44-07

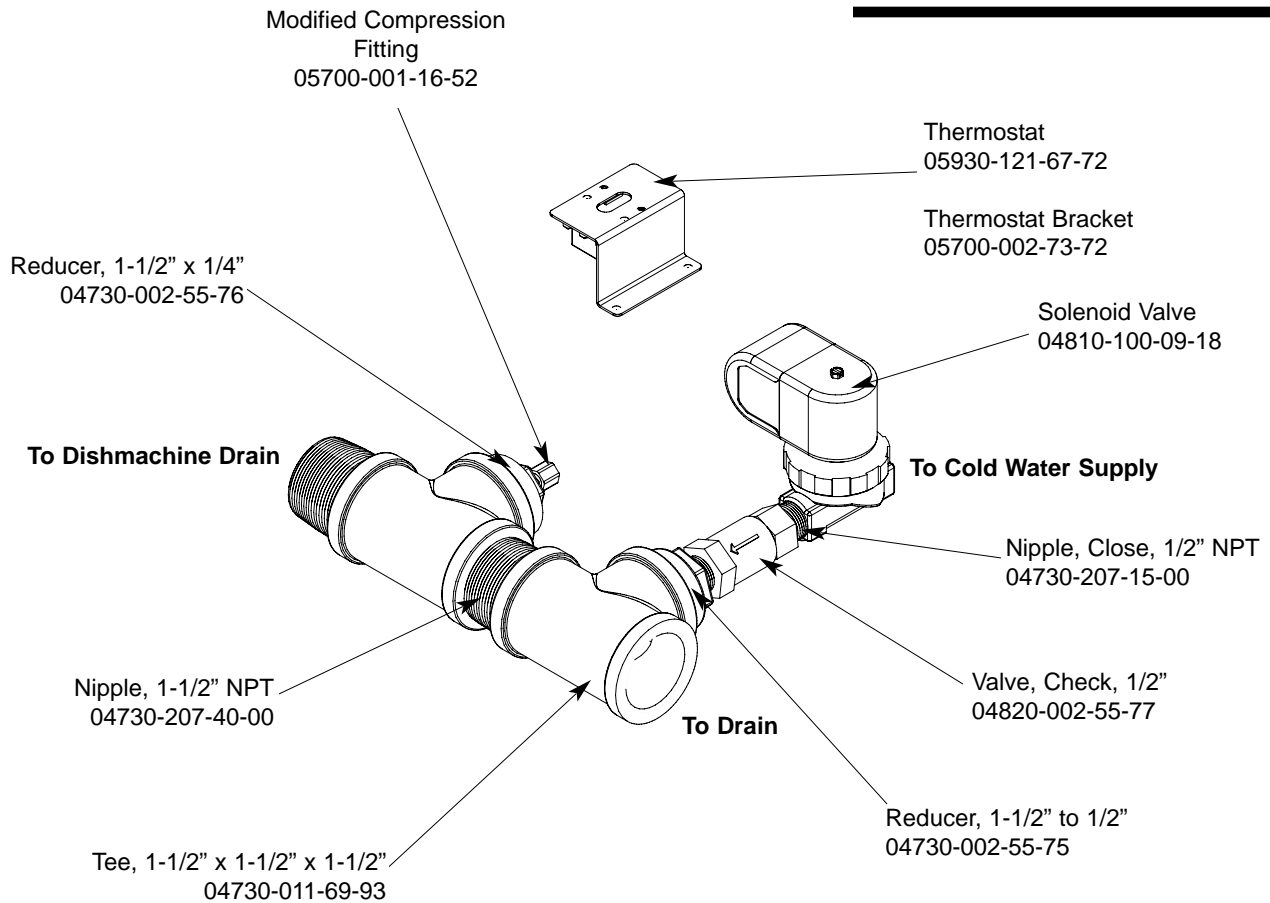

From the existing drain, attach the two additional Tees (Item 7) using the 1-1/2" NPT Close Nipples (Item 8). Tighten the Reducers (Items 6 & 9) into the Tees as shown above. Attach the Modified Compression Fitting (Item 10) into the 1-1/2" to 1/4" Reducer (Item 9). Position the bulb of the thermostat (Item 1) so that it rests approximately 1/4" from the bottom of the Tee (Item 7). Tighten the Modified Compression Fitting (Item 10) as required.

Mount the Thermostat (Item 1) to the tub using the Thermostat Bracket (Item 2) and set it for 120°F - 140°F. Install the Solenoid Valve (Item 3) to the second Tee (Item 7) and then attach to the incoming cold water line. Use pipe dope or thread tape as required to prevent any leaks.

SECTION 6: PARTS SECTION

MOTOR ASSEMBLIES

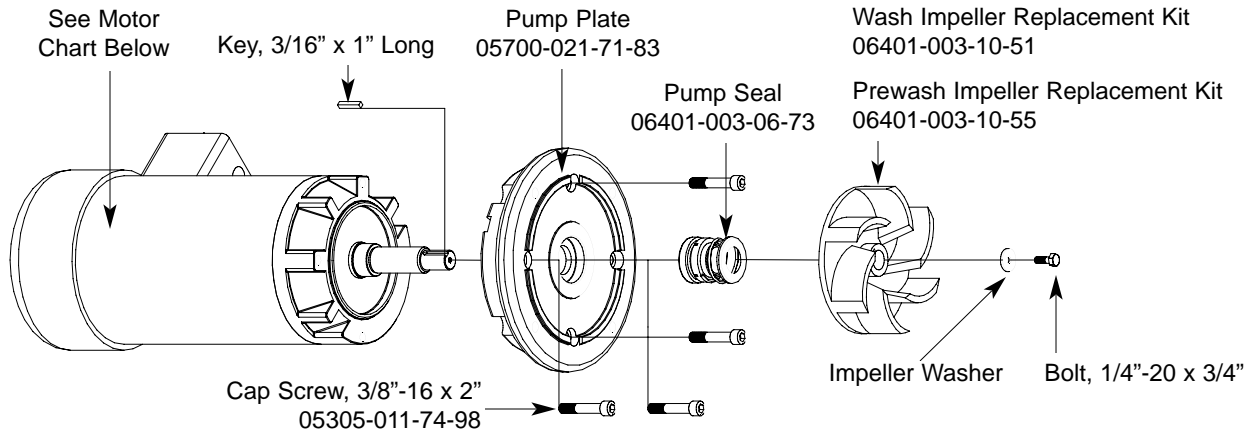

Replacement Kit Notes:

The impeller replacement kits come with the impeller, washer, key and bolt. The motor kits come with everything detailed above as well as two new mounting gaskets.

Clamp, 4 1/8" - 7" (Not Shown)
04730-002-32-15

Kit, Motor Brkt Replace
06401-021-73-42

WASH MOTOR CHART

<u>Volts</u>	<u>Phase</u>	<u>Hz</u>	<u>Motor Part Number</u>	<u>Kit Part Number</u>
208 - 230	1	60	06105-021-70-57	06401-003-09-97
200 - 230	3	60	06105-121-70-58	06401-003-09-98
460	3	60	06105-121-70-58	06401-003-09-98
575	3	60	06105-002-48-31	06401-003-09-99
600	3	60	06105-002-48-31	06401-003-09-99

PREWASH MOTOR CHART

<u>Model(s)</u>	<u>Volts</u>	<u>Phase</u>	<u>Hz</u>	<u>Part Number</u>	<u>Kit Part Number</u>
AJ-76's	208	1	60	06105-121-70-55	06401-003-10-40
	230	1	60	06105-121-70-55	06401-003-10-40
	200	3	60	06105-121-70-56	06401-003-10-38
	220	3	60	06105-121-70-56	06401-003-10-38
	230	3	60	06105-121-70-56	06401-003-10-38
	460	3	60	06105-121-70-56	06401-003-10-38
	575	3	60	06105-002-48-31	06401-003-10-41
AJ-90's	600	3	60	06105-002-48-31	06401-003-10-41
	208	1	60	06105-121-70-57	06401-003-10-42
	230	1	60	06105-121-70-57	06401-003-10-42
	200	3	60	06105-121-70-58	06401-003-10-43
	220	3	60	06105-121-70-58	06401-003-10-43
	230	3	60	06105-121-70-58	06401-003-10-43
	460	3	60	06105-121-70-58	06401-003-10-43
575	3	60	06105-002-48-31	06401-003-10-41	
600	3	60	06105-002-48-31	06401-003-10-41	

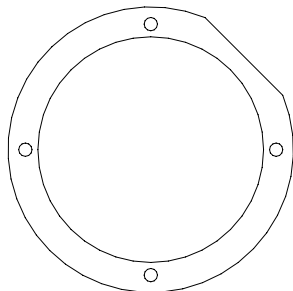
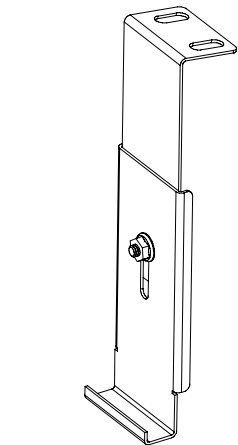

Motor Mounting Gasket
06401-003-06-75

SECTION 6: PARTS SECTION
PREWASH & WASH PUMP WELDMENTS

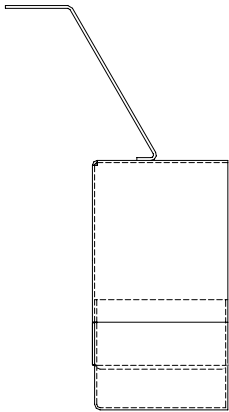

Intake Suction Scoop Weldment
 05700-021-87-60

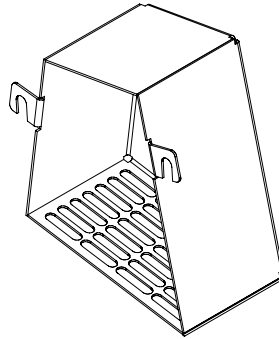

Prewash Intake
 Strainer Weldment
 05700-021-74-96

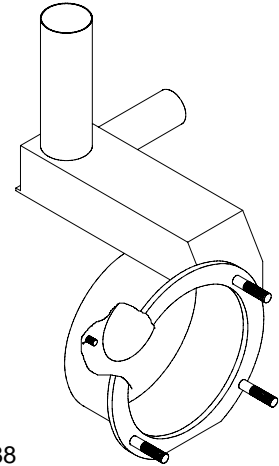

Wash Pump
 Weldment
 05700-041-68-88

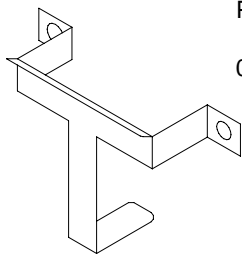

Prewash Strainer
 Bracket
 05700-021-74-94

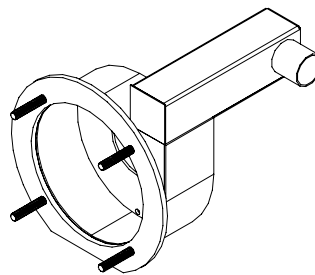

Prewash Pump Weldment
 AJ-76/AJ-90 Left to Right models:
 05700-002-10-62

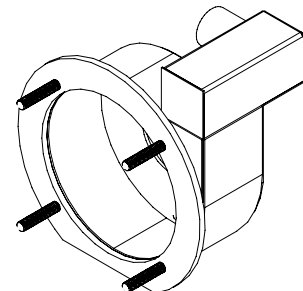

Prewash Pump Weldment
 AJ-76/AJ-90 Right to Left models:
 05700-002-11-96

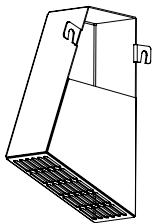

Scoop, Intake Suction Wash
 Weldment
 05700-002-51-20

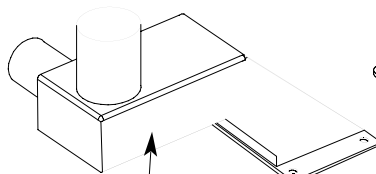

Pump Discharge
 Weldment
 05700-002-50-90

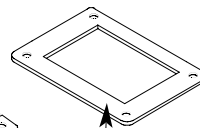

Gasket
 05330-002-54-55

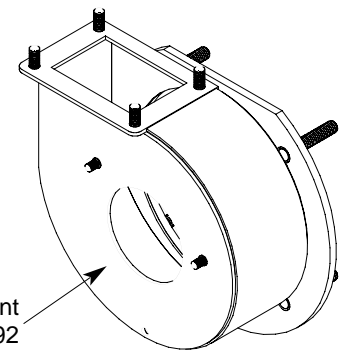

Wash Pump Weldment
 05700-002-50-92

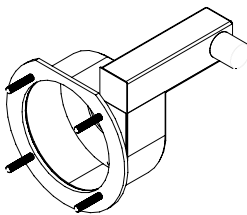

Prewash Pump Weldment
 AJ-76CGP Left to Right model
 05700-002-43-56

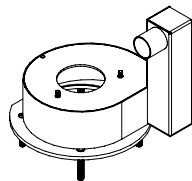

Prewash Pump Weldment
 AJ-76CGP Right to Left model
 05700-002-42-69

SECTION 6: PARTS SECTION
PREWASH ARM/UPPER WASH ARM ASSEMBLY

Replacement Kit Note:
 The replacement kit for the end cap includes the endcap, lanyard, mounting screw and the locknut.

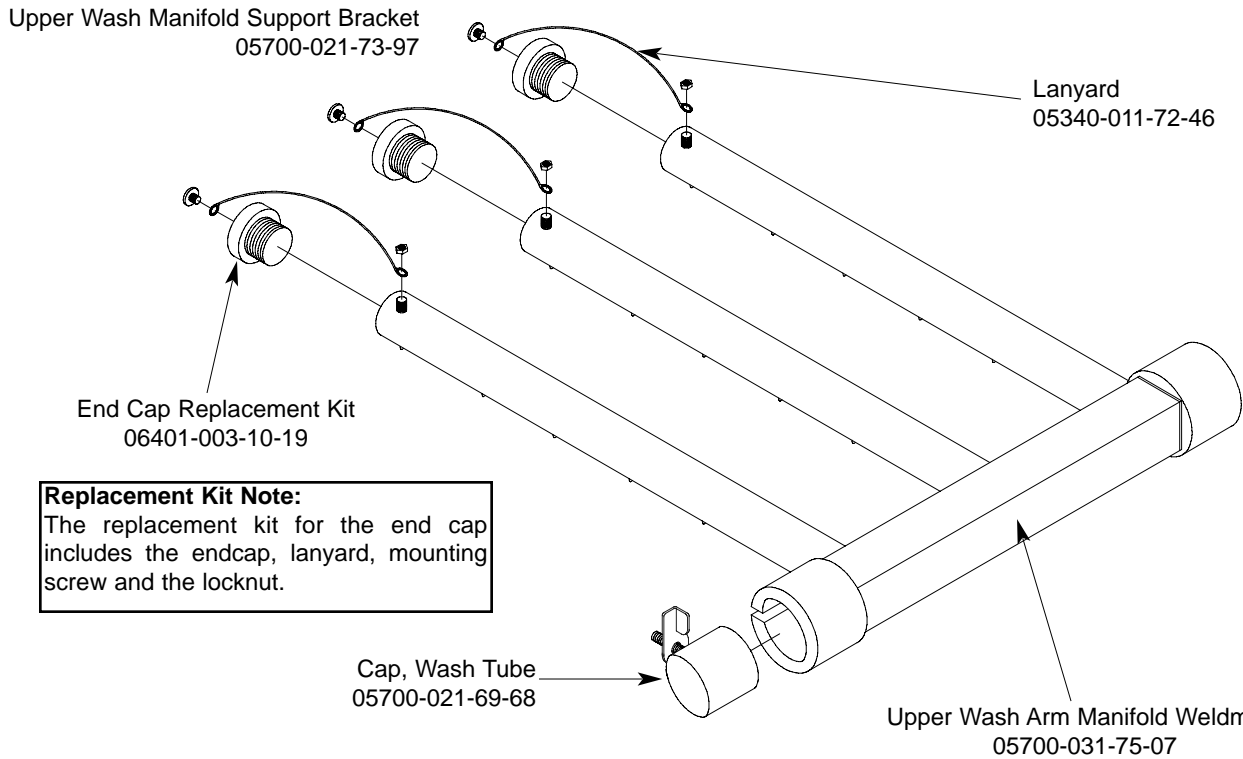
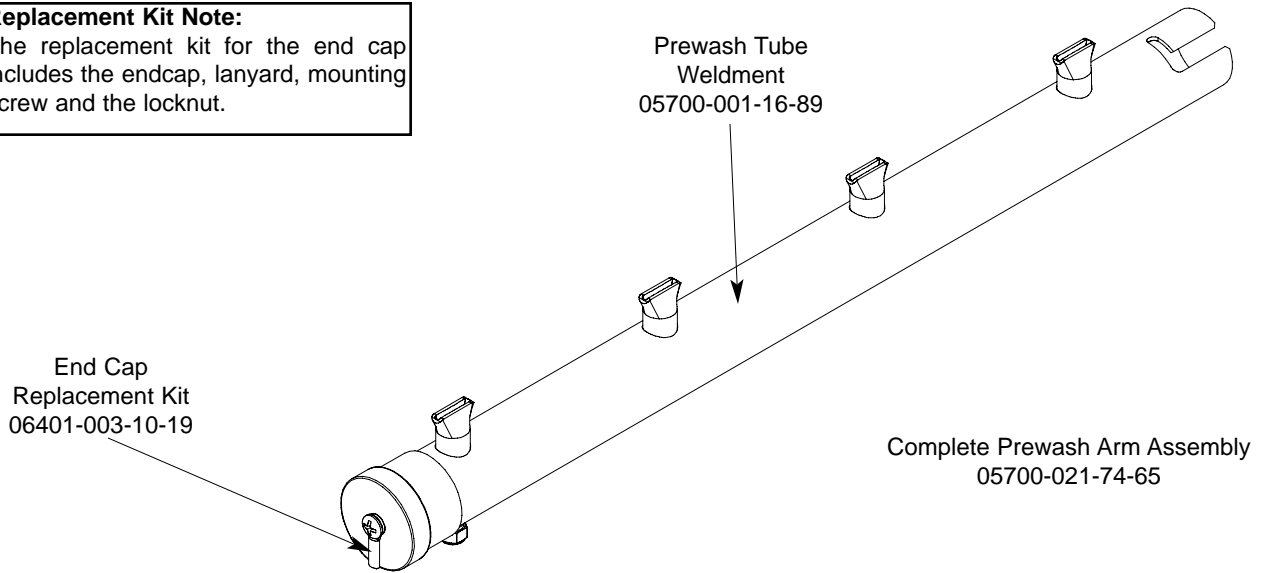

Replacement Kit Note:
 The replacement kit for the end cap includes the endcap, lanyard, mounting screw and the locknut.

Service Note:
 When replacing the 10-32 screws in the End Caps, it is recommended that a thread locking fluid be used to ensure that the screws do not back out during normal operation.

Complete Upper Arm Assembly
05700-031-75-33

SECTION 6: PARTS SECTION

LOWER WASH ARM ASSEMBLY

Lower Wash Arm Support Bracket
05700-011-71-20
Secured with Locknut, 1/4"-20 with Nylon Insert
05310-374-01-00

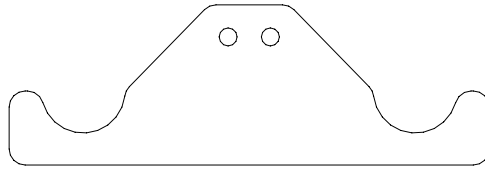

Screw, 10-32 x 3/8" Truss Head
05305-173-12-00

Replacement Kit Note:

The replacement kit for the end cap includes the end-cap, lanyard, mounting screw and the locknut.

End Cap Replacement Kit
06401-003-10-19

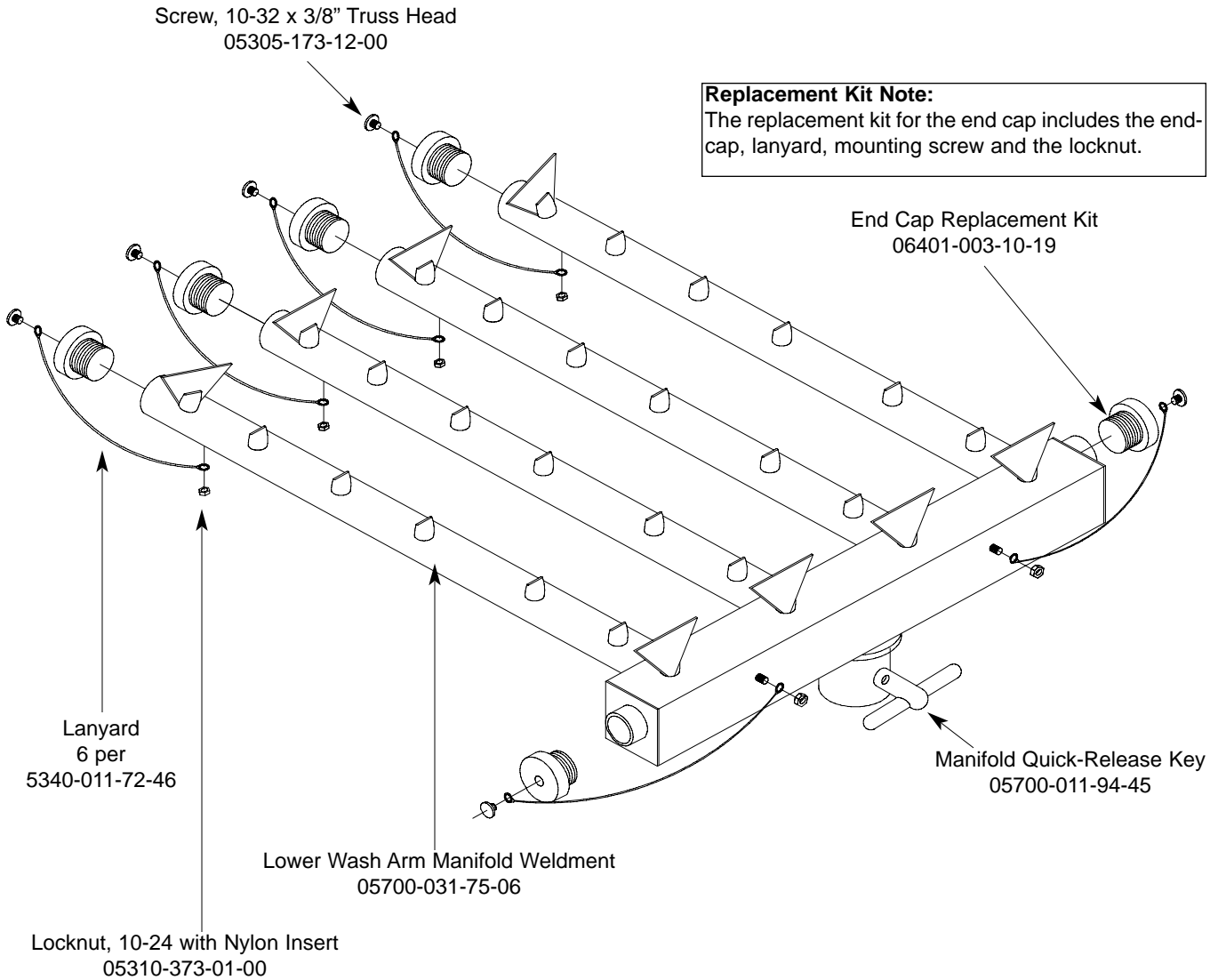

Lanyard
6 per
5340-011-72-46

Lower Wash Arm Manifold Weldment
05700-031-75-06

Manifold Quick-Release Key
05700-011-94-45

Locknut, 10-24 with Nylon Insert
05310-373-01-00

**Complete Lower Wash Arm Assembly
05700-031-75-32**

SERVICE NOTE: When replacing the 10-32 screws in the End Caps, it is recommended that a thread locking fluid be used to ensure that the screws do not back out during normal operation.

SECTION 6: PARTS SECTION
CURTAINS/TUB MAGNETS

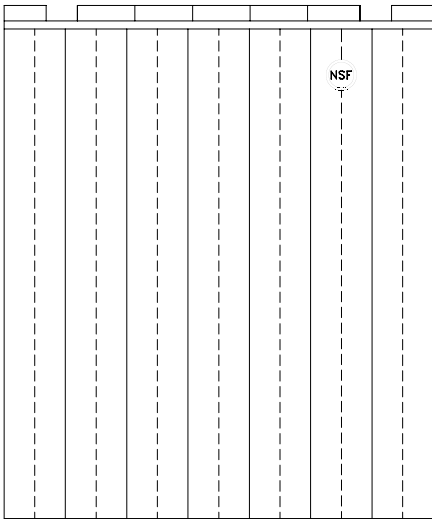

Curtain, 24 1/2" Long x 20-1/2" Wide
CGP MODELS ONLY
08415-002-47-37

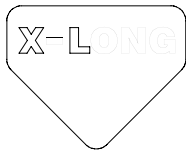

Extra Long Curtain Decal
CGP MODELS ONLY
09905-002-52-69

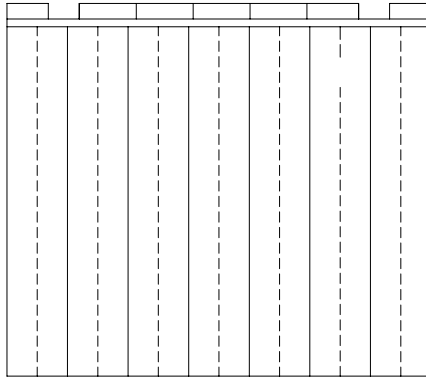

Curtain, 21" Long x 20-1/2" Wide
08415-131-73-45

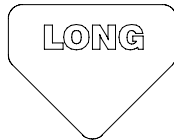

Long Curtain Decal
09905-011-73-84

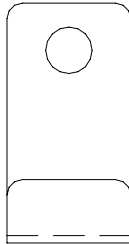

Curtain Hook
05700-011-83-54

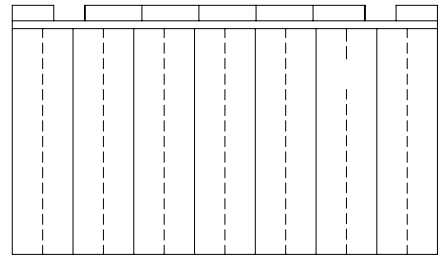

Curtain, 12" Long x 20-1/2" Wide
08415-131-73-44



Short Curtain Decal
09905-011-73-82

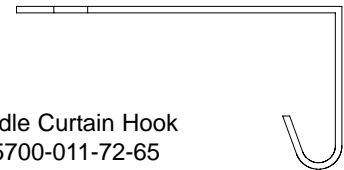

Middle Curtain Hook
05700-011-72-65

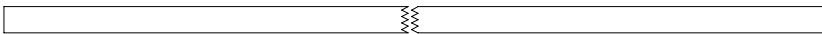

Curtain Rod
05700-021-73-43

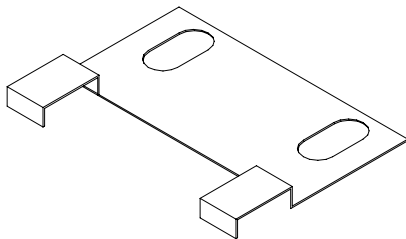

Limit Switch Bracket
05700-021-71-18

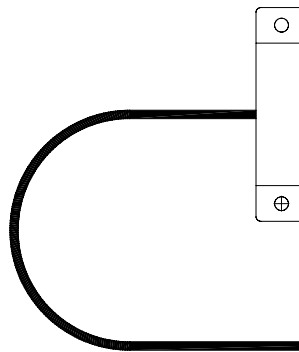

Conveyor Switch Replacement Kit
06401-003-11-79

Replacement Kit Note:
The conveyor switch replacement kit comes with the switch, a terminal and a wire nut.

Service Note:
The cord for the conveyor switch needs to be cut to length in the field and have the pink terminal applied there.

SECTION 6: PARTS SECTION

FINAL RINSE ASSEMBLY

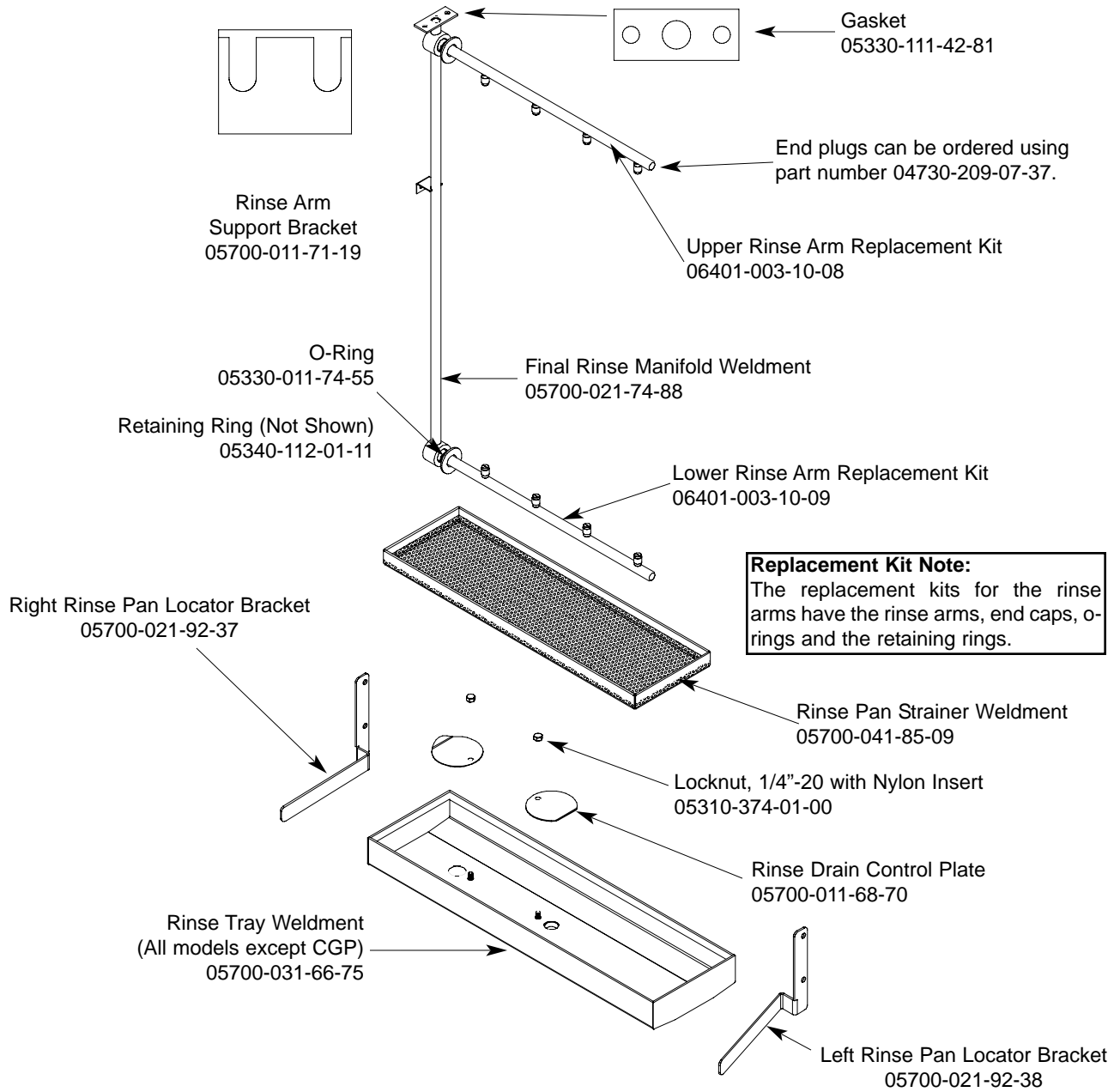

Optional Parts for CGP Models

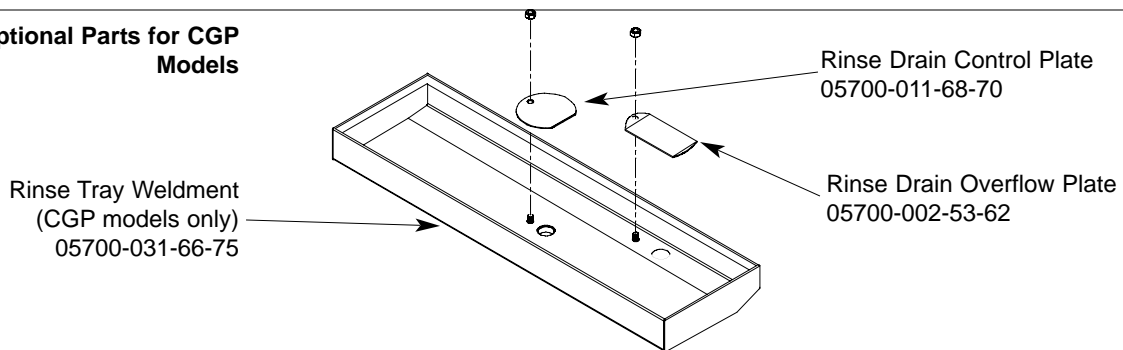

SECTION 6: PARTS SECTION
DRIVE ASSEMBLY

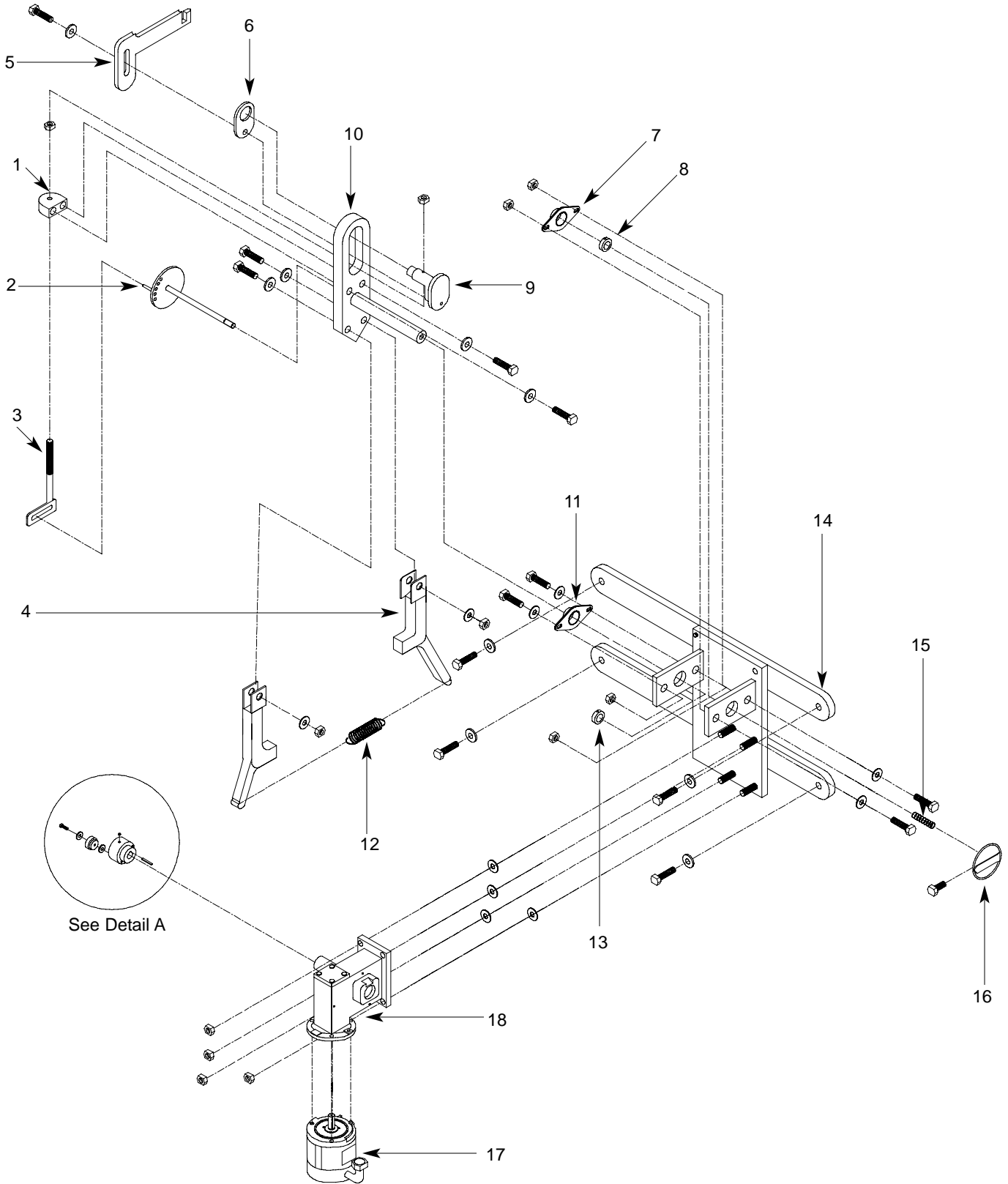

SECTION 6: PARTS SECTION

DRIVE ASSEMBLY (CONTINUED)

ITEM	QTY	DESCRIPTION	Mfg. No.
1	1	Drive Plate and Rod Weldment Replacement Kit with Expansion Legs Replacement Kit with Expansion Legs/Adjuster Crank	05700-021-67-44 06401-021-86-80 06401-011-94-54
2	1	Adjuster Crank Assembly	05700-021-69-95
3	1	Scotch Yoke Weldment Replacement Kit	06401-003-08-48
4	2	Coupling & Expansion Leg Weldment	05700-021-67-50
5	1	Pawl Bar Drive Linkage Casting	09515-021-87-73
6	1	Spacer Plate	05700-011-67-58
7	2	Pillow Block Replacement Kit	06401-003-08-50
8	2	Shaft Collar	05700-011-89-18
9	1	Drive Socket	05700-021-67-39
10	1	Drive Plate	05700-021-67-42
11	2	Pillow Block	03120-021-71-87
12	1	Drive Spring	05315-011-83-51
13	2	Shaft Collar	05700-011-89-18
14	1	Drive Motor Mounting Bracket	05700-031-73-56
15	1	Adjuster Spring	05315-011-71-90
16	1	Adjusting Handle Weldment	05700-021-72-28
17	1	Drive Motor Replacement Kits Drive Motor (50 Hz Models)	06401-003-08-41
	1	Drive Motor (208-230 Volt, 60 Hz, Single Phase Models)	06401-003-08-42
		Drive Motor (208-230 Volt, 60 Hz, Three Phase Models)	06401-003-08-40
		Drive Motor (600 Volt, 60 Hz, Three Phase Models)	06401-003-08-43
18	1	Gear Drive	06105-011-87-20
19	1	Roller Bearing	03120-011-71-81
20	1	Drive Hub	05700-011-67-97

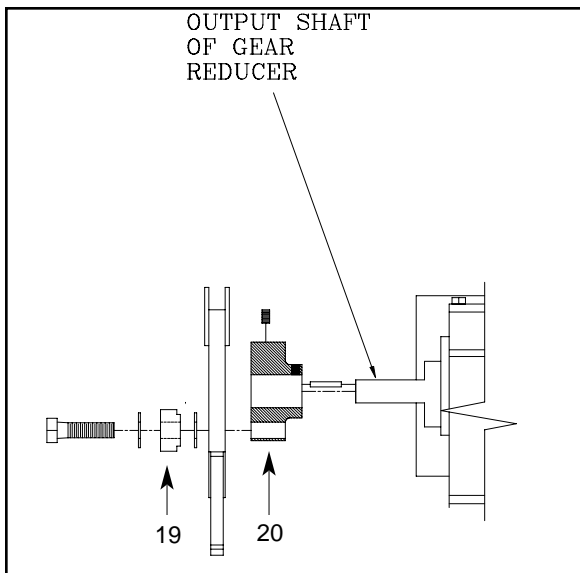

Detail A

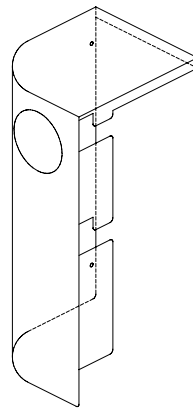

Front Drive Motor Cover
Replacement Kit
06401-003-11-64

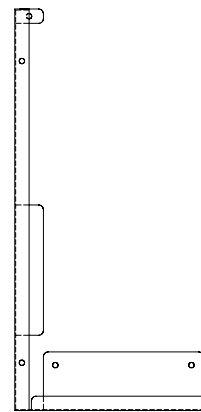

Rear Drive Motor Cover
Replacement Kit
06401-003-10-18

Replacement Kits Notes:

The replacement kits for the drive motor covers come with the weldments and the mounting hardware.

SECTION 6: PARTS SECTION

LUBRICATION CHART FOR DRIVE GEAR

Note: The maintenance procedures detailed here are manufacturer's instructions for the WINSMITH brand of gear reducer that is installed on the rack conveyors covered in this manual.

Ambient Temperature	-30 - 15°F	16 - 50°F	51 - 95°F	51 - 95°F	96 - 131°F	96 - 131°F
Final Stage Worm Speed ¹	up to 2000 FPM	up to 2000 FPM	up to 450 FPM	above 450 FPM	up to 450 FPM	above 450 FPM
ISO Viscosity Grade	220	460	680	460	680	460 ¹
AGMA Lubricant No.	5S	#7 Compounded	#8 Compounded	#7 Compounded	8S	7S
Mobil	SHC 630	600W Super Cylinder	Extra Hecla Super	600W Super Cylinder	SHC 636	SHC 634
American Lubricants	SHC-90W	AGMA #7 Gear Oil	AGMA #8 Gear Oil	AGMA #7 Gear Oil	N/A	N/A
Castrol	Tribol 800/220	Tribol 1105-7C	Tribol 1105-8C	Tribol 1105-7C	Tribol 800/680	Tribol 800/460
Chevron	Tegra 220	Cylinder Oil W460	Cylinder Oil W680	Cylinder Oil W460	Tegra 680	Tegra 460
Conoco	Syncon R & O 220	Inca Oil 460	Inca Oil 680	Inca Oil 460	N/A	Syncon R & O 460
Exxon (Esso)	Teresstic SHP220	Spartan EP 460	Spartan EP 680	Spartan EP 460	Teresstic SHP 680	Teresstic SHP 460
Fiske Brothers	SPO-MG	SPO-277	SPO-288	SPO-277	N/A	N/A
Shell	Omala RL 220	Valvata J 460	Valvata J 680	Valvata J 460	Omala RL 680	Omala RL 460
Texaco	Pinnacle 220	Vanguard 460	Vanguard 680	Vanguard 460	Pinnacle 680	Pinnacle 460

(1) The sliding velocity in feet per minute (FPM) for standard ratios is determined by multiplying the speed of the worm in RPM by the factor from the table below. For selecting proper lubricant, use the speed of the worm in the final stage (input RPM divided by the first stage ratio).

SECTION 6: PARTS SECTION
DOOR ASSEMBLIES

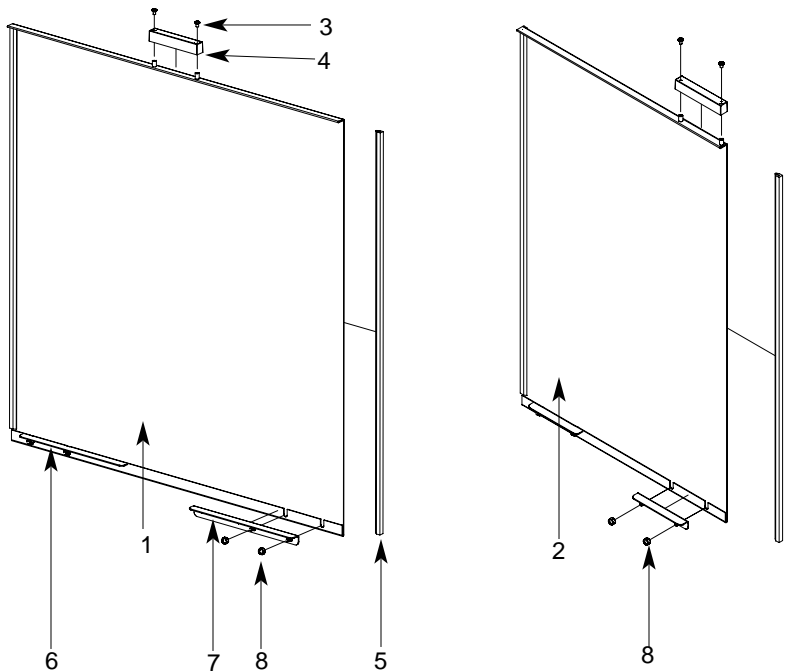

Locknut, 1/4"-20 with Nylon Insert
05310-374-01-00

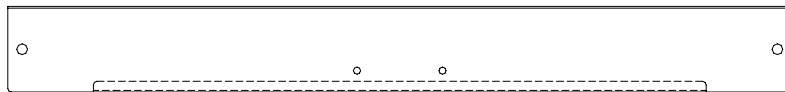

Wash Door Hood Support: 05700-031-84-13
22" Prewash Door Hood Support: 05700-031-84-14

Door Stiffener (Not Shown) 05700-031-83-43

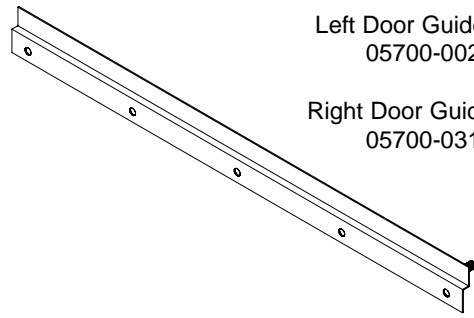

Left Door Guide Weldment
05700-002-32-51

Right Door Guide Weldment
05700-031-76-44

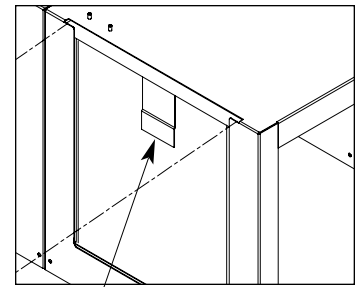

Door Catch Weldment
05700-031-84-80

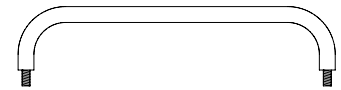

Wash Door Handle Weldment
05700-011-82-63

Prewash Door Handle Weldment
05700-011-80-45

ITEM	QTY	DESCRIPTION	Mfg. No.
1	1	Wash Door Weldment	05700-003-13-35
2	1	Prewash Door Weldment	
		Left to Right Model	05700-003-13-42
		Right to Left Model	05700-003-13-40
3	1	Screw, 8-32 x 1/4" Long	05305-172-09-00
4	1	Door Switch Magnet	05700-111-51-68
5	1	Door Guide	05700-111-70-92
6	1	Door Stop Weldment, Right	05700-002-96-33
7	1	Door Stop Weldment, Left	05700-002-96-32
8	2	Locknut, 10-24 SS Hex with Nylon Insert	05310-373-01-00
9	2	Door Stop Weldment, Prewash	05700-002-05-46

SECTION 6: PARTS SECTION
PAWL BAR MISCELLANEOUS COMPONENTS

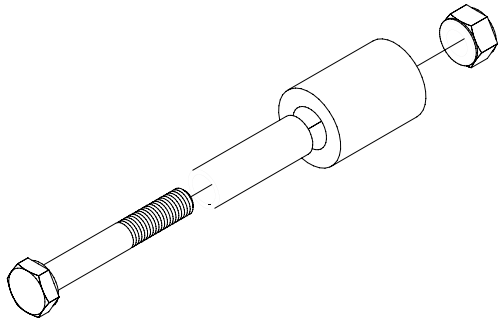

Pawl Bar Roller Replacement Kit
 06401-003-11-80

Replacement Kit Notes:

The replacement kit for the pawl bar roller comes with the roller, roller shaft, hardware and locknut as shown.

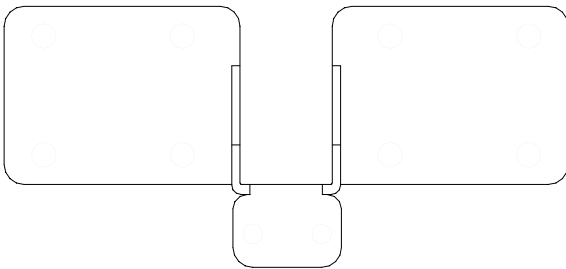

Pawl Bar Bracket (without tabs) Weldment
 05700-031-92-36

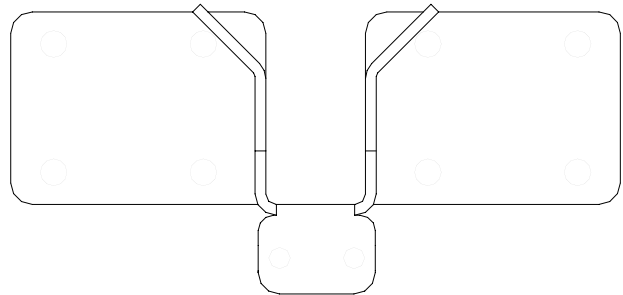

Pawl Bar Bracket (with studs) Weldment
 05700-031-84-68

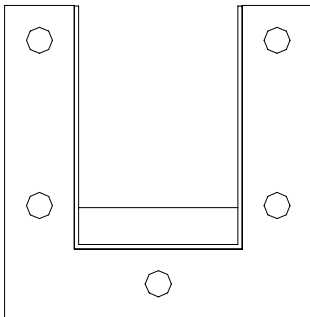

Pawl Bar Gutter Weldment Replacement Kit
 06401-003-09-95

Replacement Kits Notes:

The pawl bar gutter weldment replacement kit contains the weldment, a gasket and the mounting hardware. The guide block kit contains both blocks and a gasket.

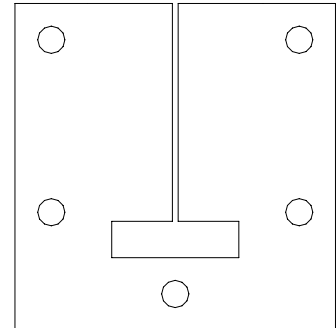

Pawl Bar Gutter Gasket
 05330-011-68-55

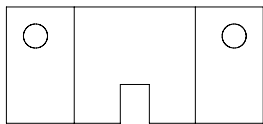

Top Guide Block

Guide Block Replacement Kit
 06401-003-10-15

Bottom Guide Block

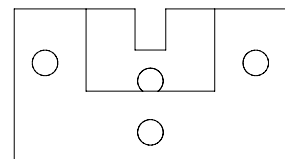

Service Note: It is highly recommended that when changing out one guide block, that the other be changed out as well, along with the gasket.

SECTION 6: PARTS SECTION

AJ-54 PAWL BAR ASSEMBLY

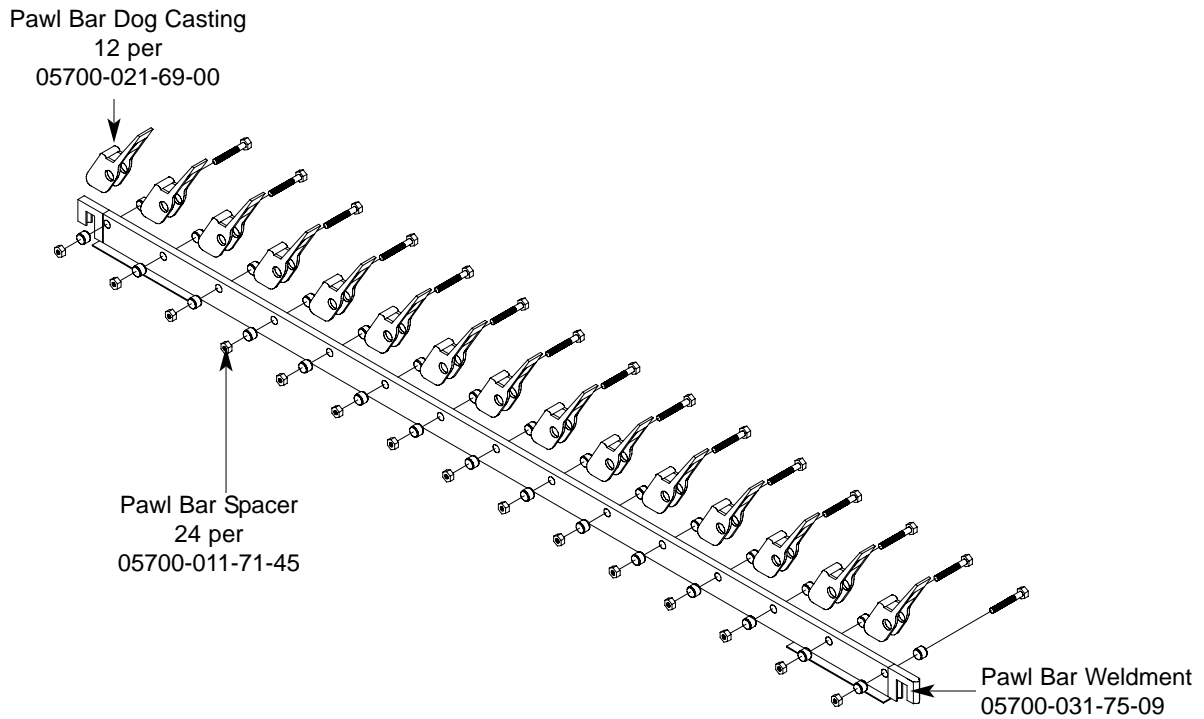

AJ-54 Complete Assembly with Hardware
06401-131-81-01

AJ-54 Prison Assembly with Hardware
06401-231-81-01

SECTION 6: PARTS SECTION

AJ-76 PAWL BAR ASSEMBLIES

Left to Right Assembly

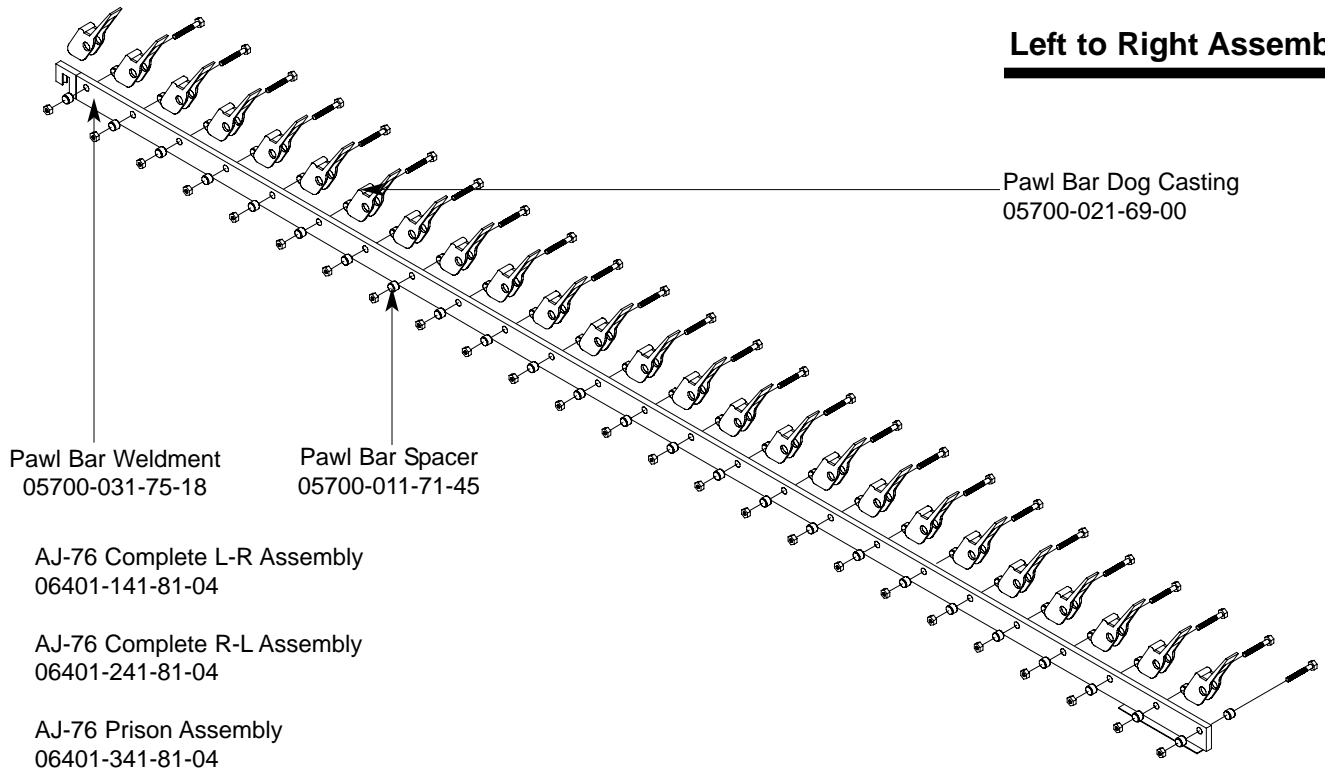

Right to Left Assembly

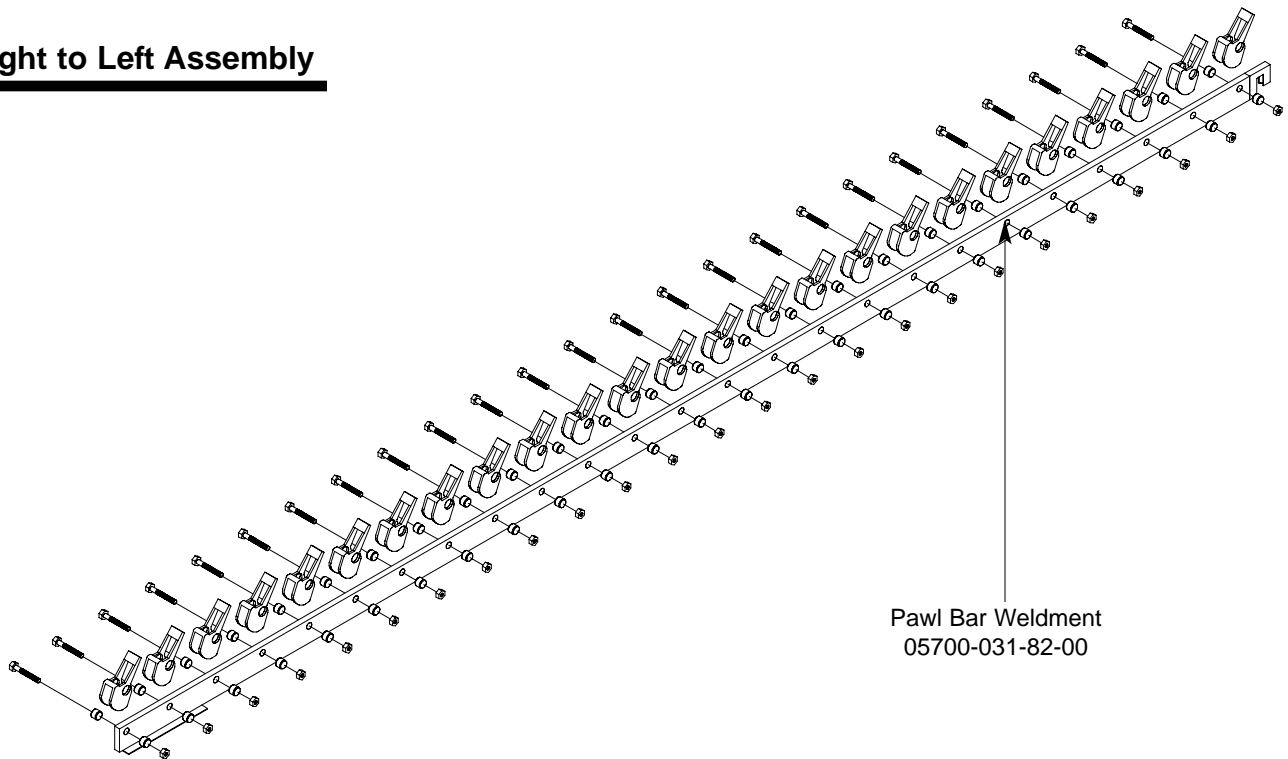

SECTION 6: PARTS SECTION

AJ-90 PAWL BAR ASSEMBLIES

Left to Right Assembly

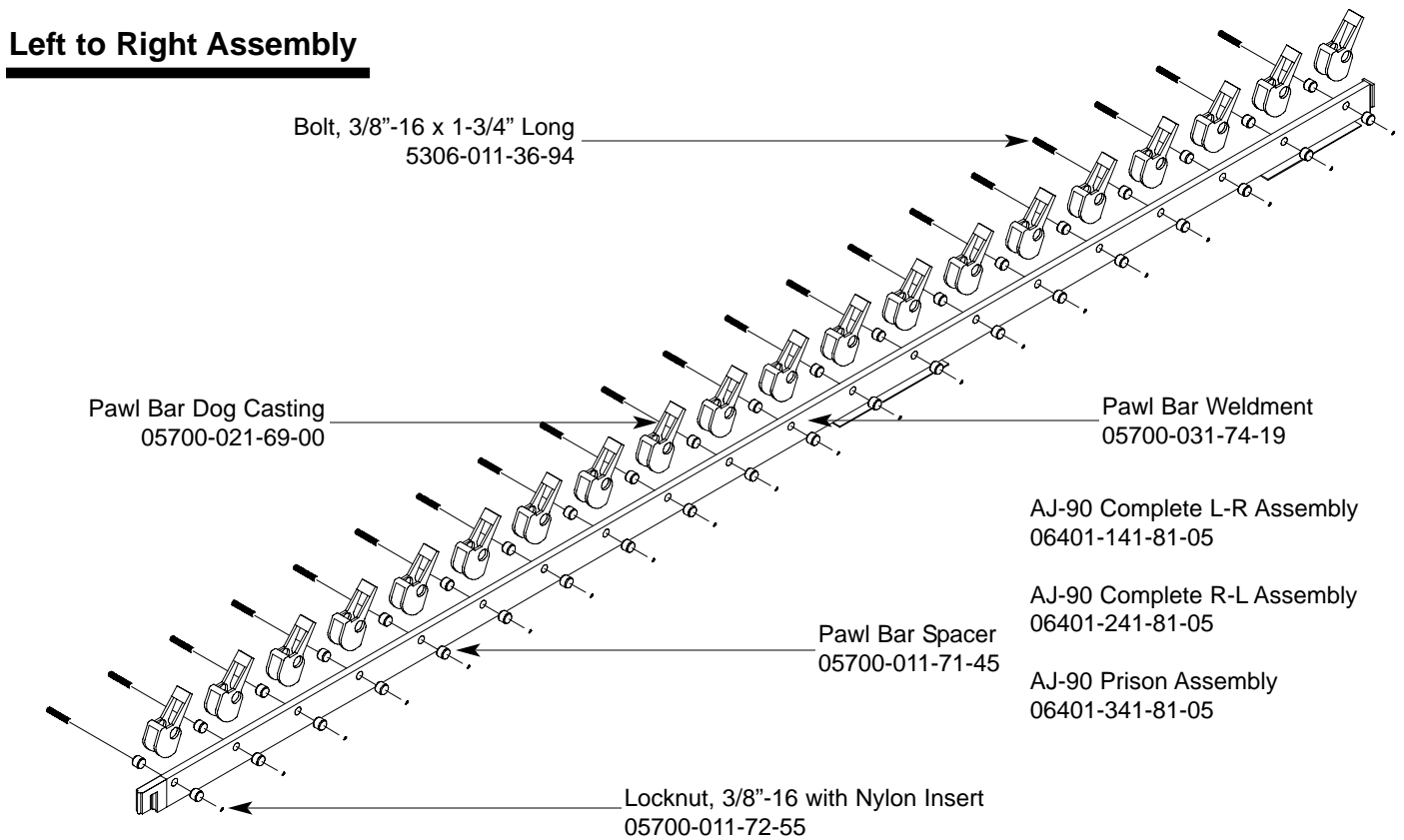

Right to Left Assembly

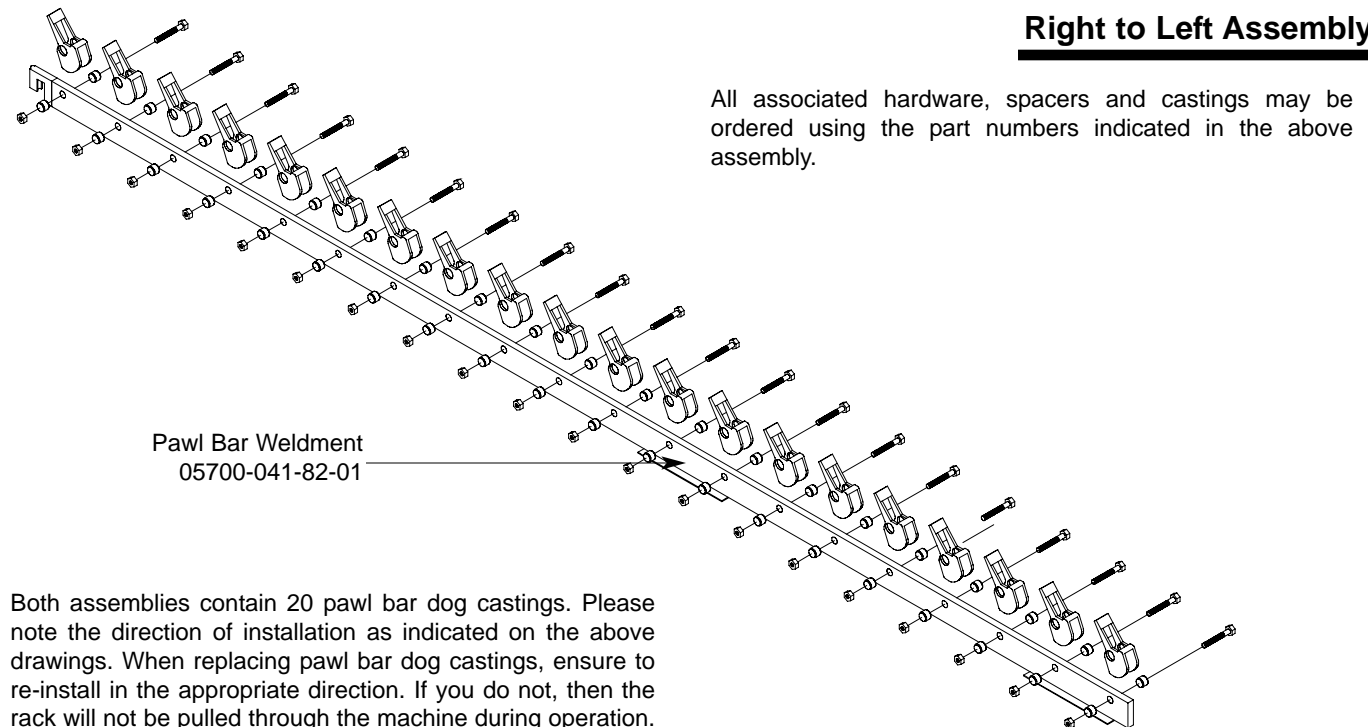

Both assemblies contain 20 pawl bar dog castings. Please note the direction of installation as indicated on the above drawings. When replacing pawl bar dog castings, ensure to re-install in the appropriate direction. If you do not, then the rack will not be pulled through the machine during operation.

SECTION 6: PARTS SECTION

AJ-54 RACK RAIL ASSEMBLY

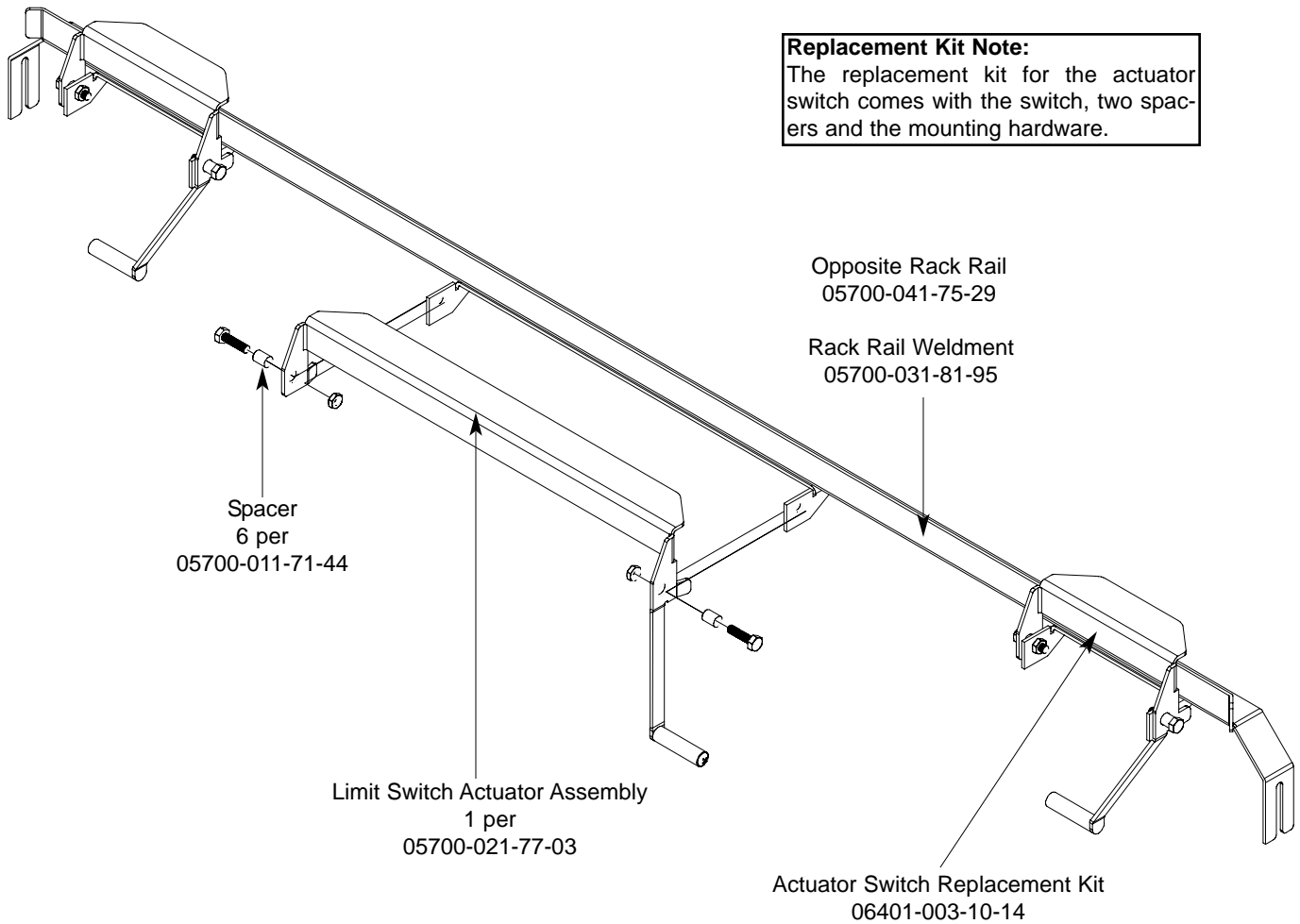

SECTION 6: PARTS SECTION

AJ-76 RACK RAIL ASSEMBLIES

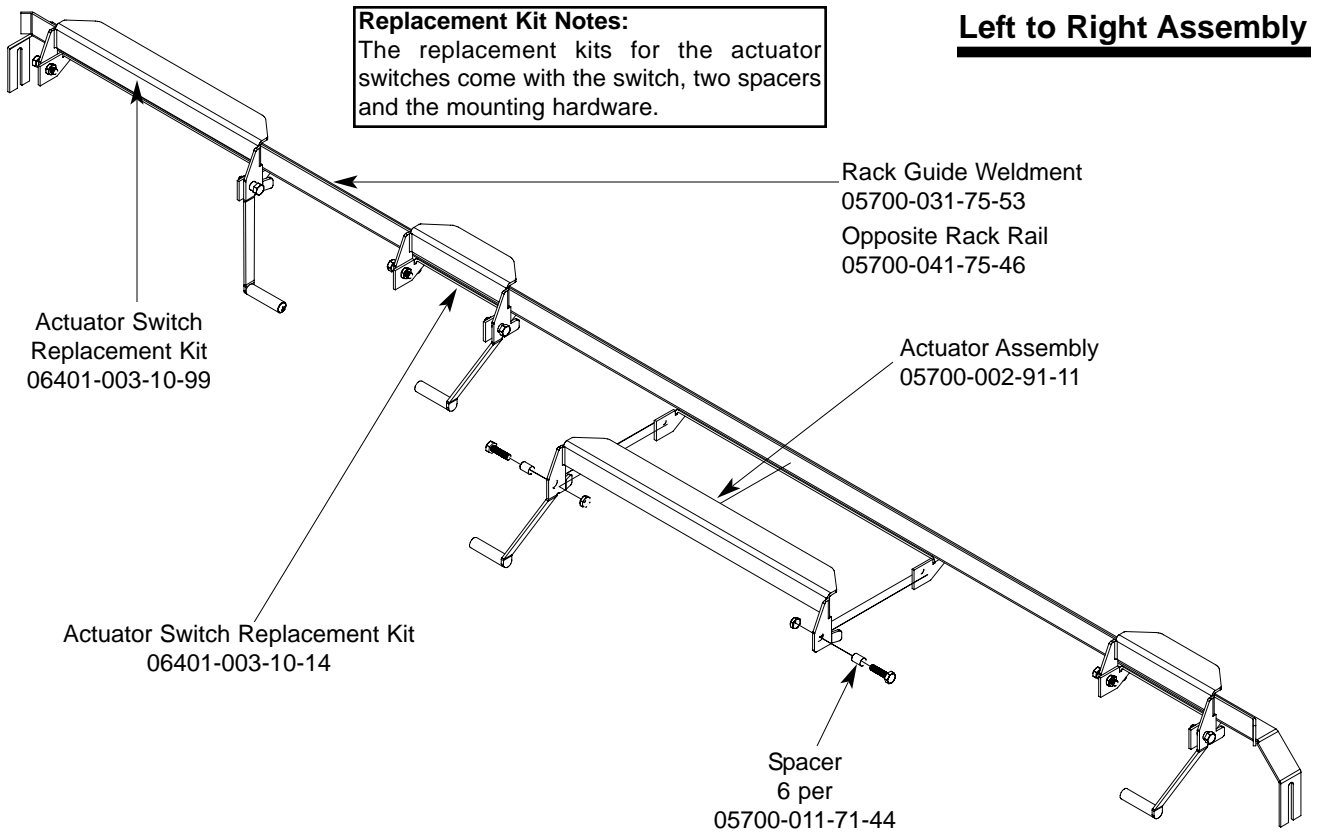

Right to Left Assembly

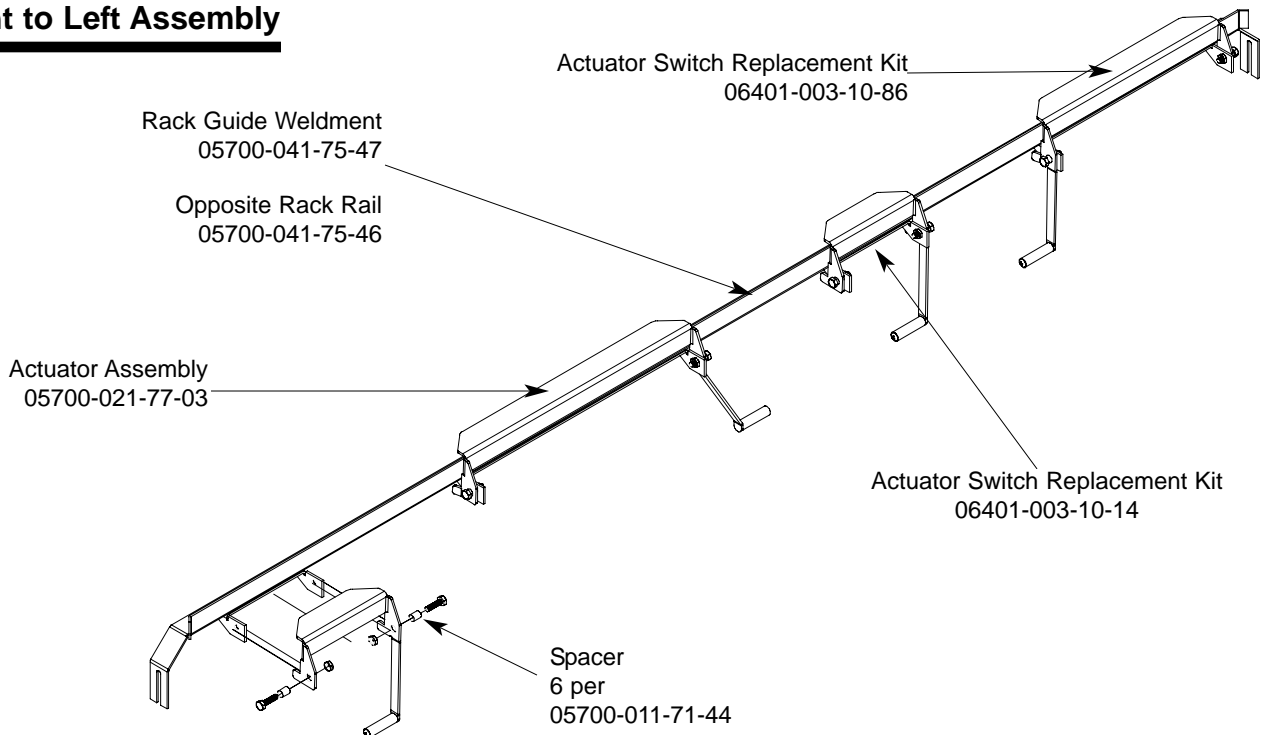

SECTION 6: PARTS SECTION

AJ-90 RACK RAIL ASSEMBLIES

Left to Right Assembly

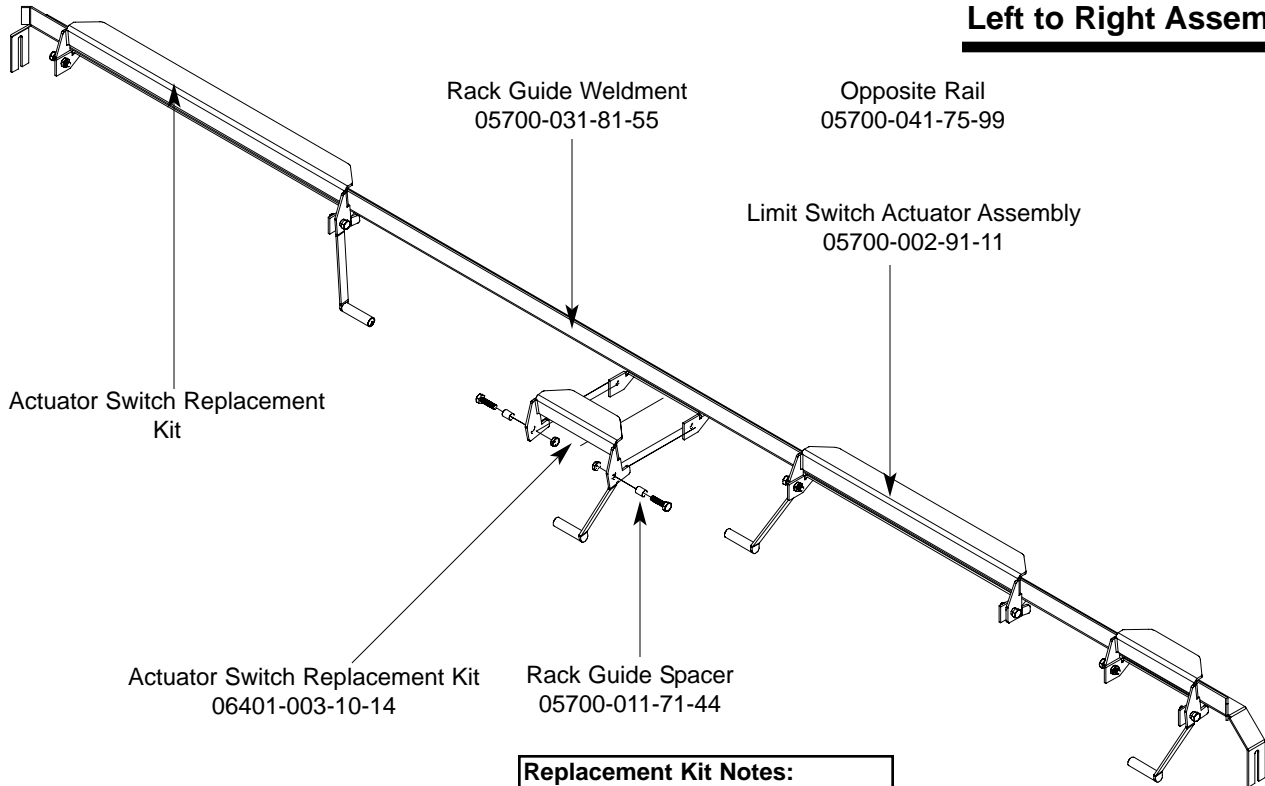

Replacement Kit Notes:

The replacement kits for the actuator switches come with the switch, two spacers and the mounting hardware.

Right to Left Assembly

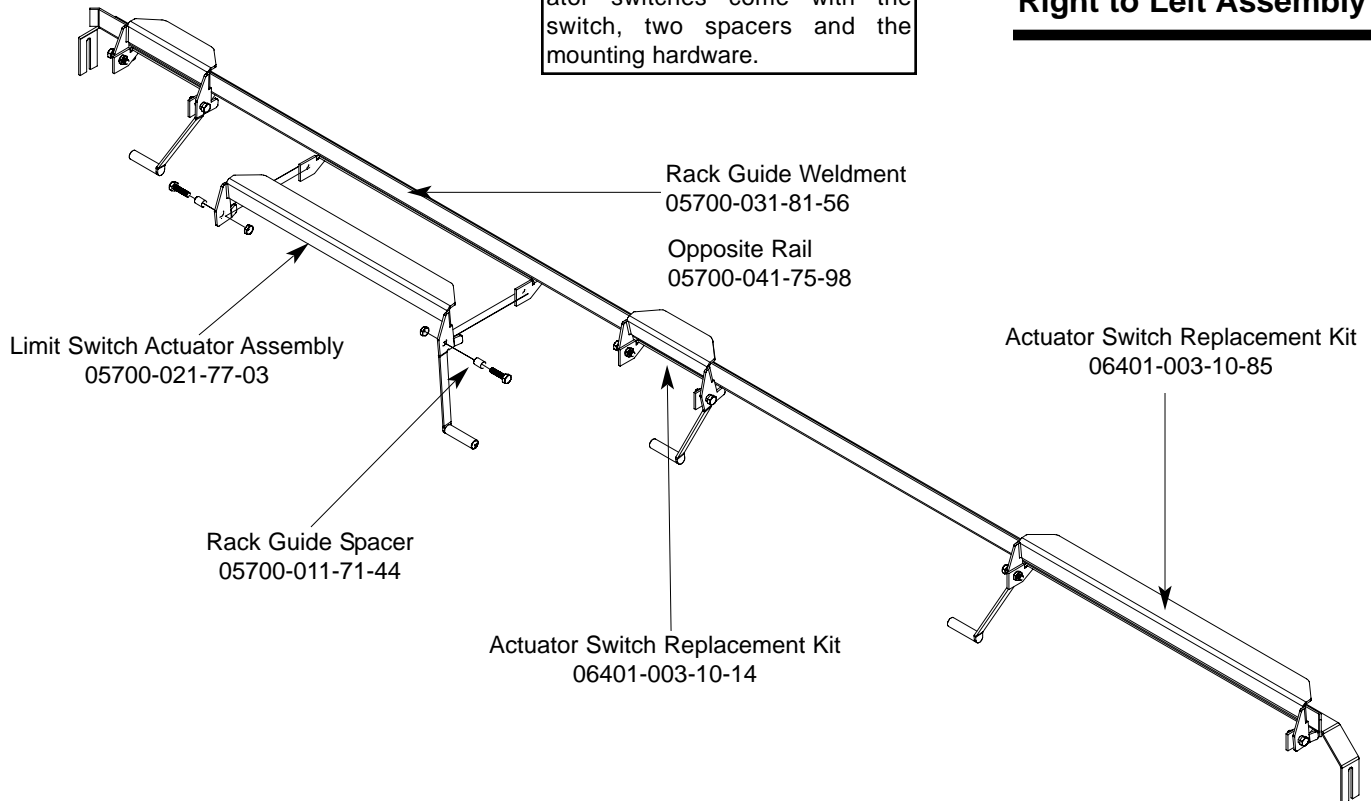

SECTION 6: PARTS SECTION
MISCELLANEOUS PARTS AND WELDMENTS

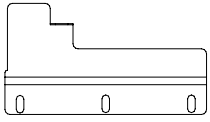

Plate, Left Water Directional
 05700-021-79-27

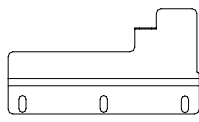

Plate, Right Water Directional
 05700-021-79-23

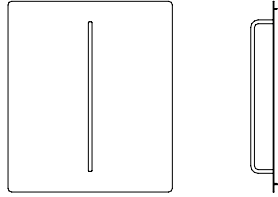

Run Off Sheet Weldment
 05700-021-71-39

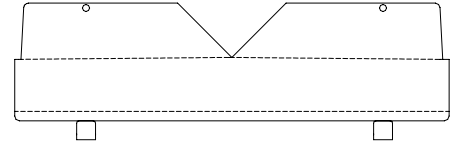

Splash Shield Weldment
 05700-031-85-16

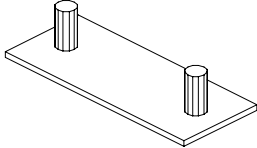

Hole Direction Plate Replacement Kit
 06401-003-10-00

Replacement Kit Note:
 The kit for the hole direction plate comes with the plate, a new gasket and the mounting hardware.

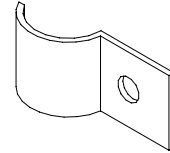

Pipe Clamp
 05700-000-35-05

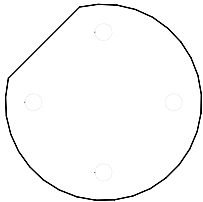

Rinse Drain Plate Replacement Kit
 (CGP Models Only)
 06401-003-10-07

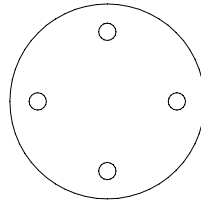

Rinse Drain Plug Replacement Kit
 06401-003-10-06

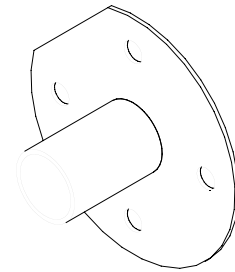

Rinse Drain Weldment Replacement Kit
 06401-003-10-05

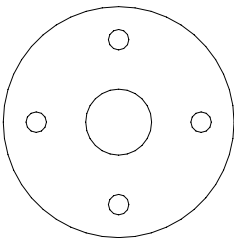

Rinse Drain Plate Gasket
 05330-011-72-27

Replacement Kits Notes:
 The kits for the drain weldments and drain plugs come with the weldments/parts, a new gasket and the mounting hardware.

SECTION 6: PARTS SECTION
MANIFOLDS/STRAINER SUPPORT WELDMENTS

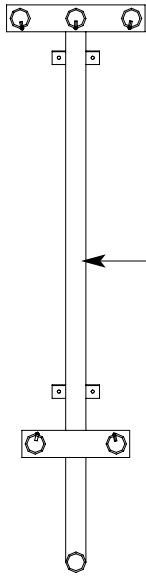

Prewash Manifold Weldment
 AJ-66 Models Only
 05700-031-69-70

Prewash Manifold Weldment
 AJ-80 Models Only
 05700-002-24-94

Prewash Manifold Weldment
 (CGP Models Only)
 05700-002-59-51

Wash Manifold Weldment
 05700-031-71-13

Wash Manifold Weldment
 (CGP Models Only)
 05700-002-51-14

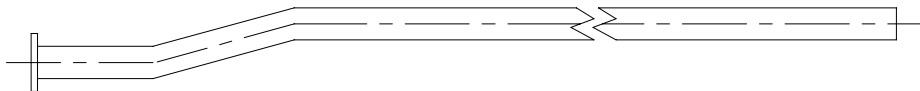
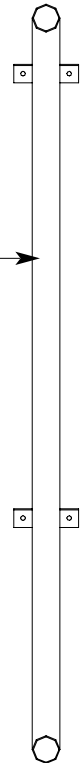

Wash Fill Tube Weldment
 05700-021-71-21

Vellumoid Gasket
 05330-111-42-81

Prewash Fill Tube Weldment
 (AJ-66 & AJ-80 Models Only)
 05700-021-74-76

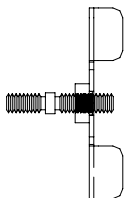

Shoulder Bolt Wingnut Weldment
 05700-002-46-02

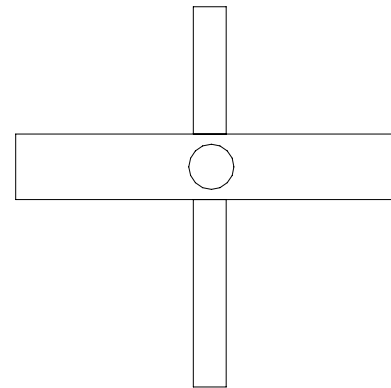

Wash Strainer Separator Weldment
 05700-031-84-38

SECTION 6: PARTS SECTION
STRAINERS

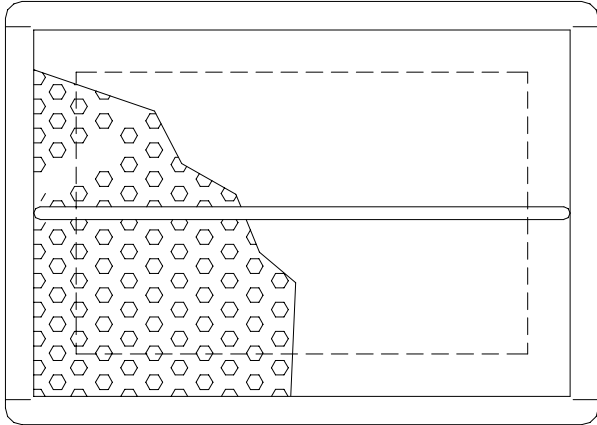

Front Strainer Weldment
05700-021-85-10

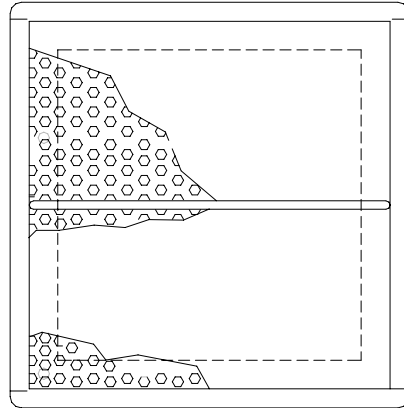

Back Strainer Weldment
05700-021-85-11

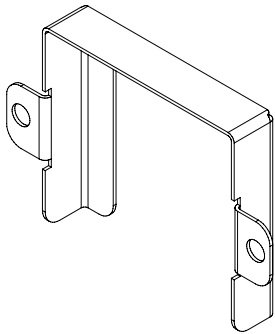

Overflow Strainer Support
05700-001-96-48

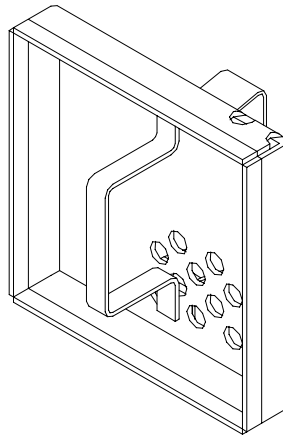

Drain Guard
Strainer Weldment
05700-002-09-15

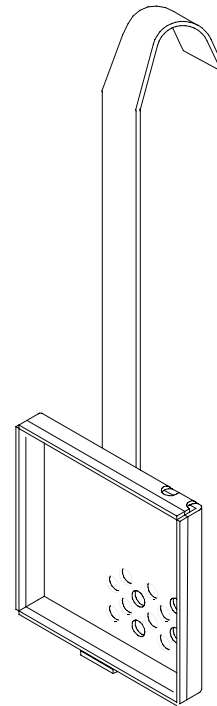

Wash Intake Strainer Weldment (CGP Models)
05700-002-51-52

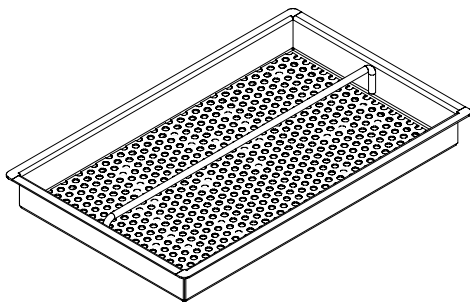

Tub Strainer Weldment (CGP Models)
05700-002-03-21

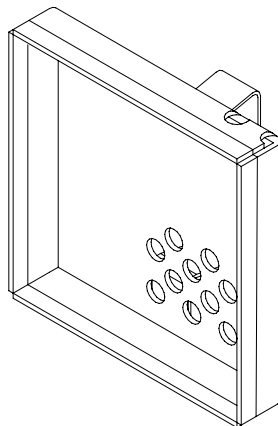

Screen Strainer
with Handle Weldment
05700-002-09-04

SECTION 6: PARTS SECTION
FLOAT SWITCH COMPONENTS/SCRAP BASKETS

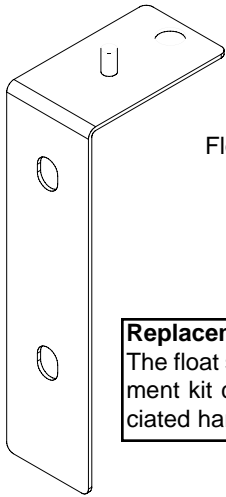

Float Switch Support Bracket
 Replacement Kit
 06401-003-11-77

Replacement Kit Note:
 The float switch support bracket replacement kit contains the bracket and associated hardware for mounting.

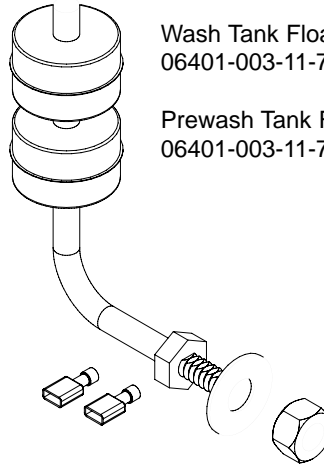

Wash Tank Float Switch Replacement Kit
 06401-003-11-75

Prewash Tank Float Switch Replacement Kit
 06401-003-11-76

Replacement Kit Note:
 The float switch replacement kits contain the float switch with associated terminals, the flat washer and the nut.

Service Agent Note:
 Remember than when reinstalling the float switch that the flat washer goes inside against the tub wall while the nut is on the outside of the tub.

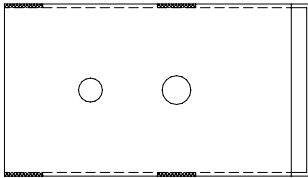

Float Switch Cover
 05700-021-75-71

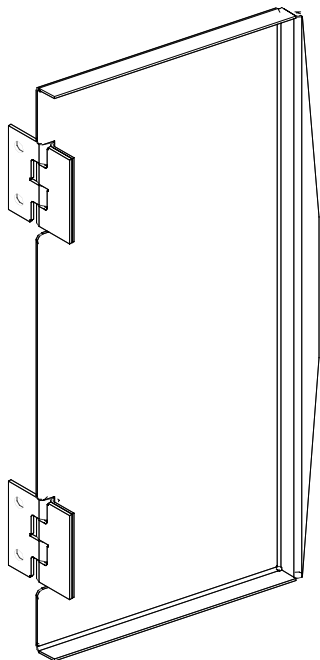

Scrap Basket Lid
 Weldment
 05700-002-56-55

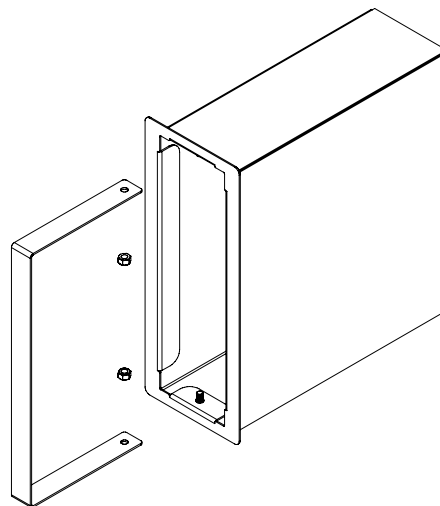

Scrap Basket Assembly
 06401-011-87-78

SECTION 6: PARTS SECTION
VENT COWL ASSEMBLY/VENT SCOOP OPTION

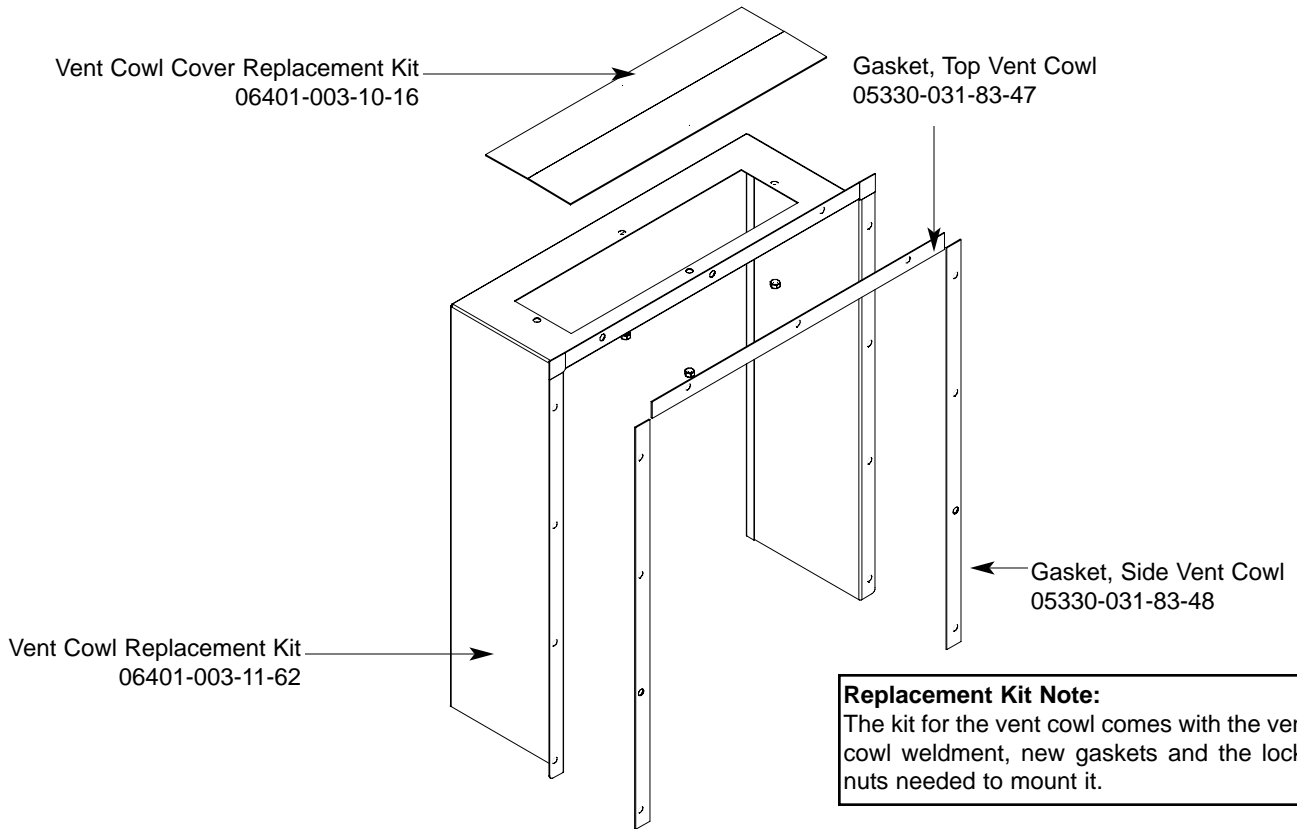

VENT SCOOP OPTION

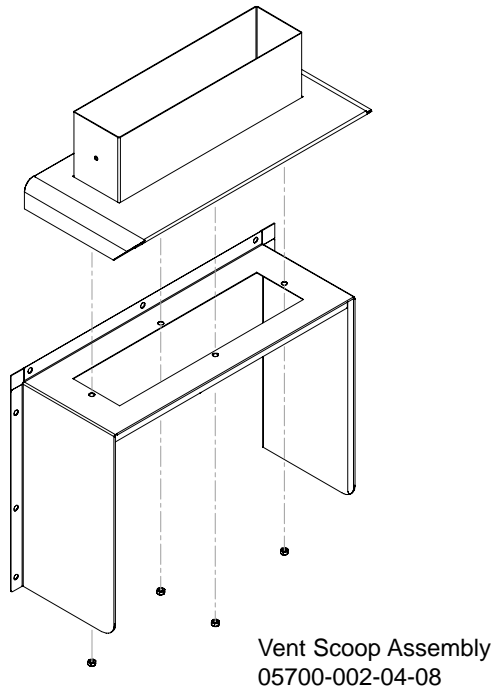

SECTION 6: PARTS SECTION

EXHAUST FAN CONTROL/TABLE LIMIT SWITCH OPTIONS

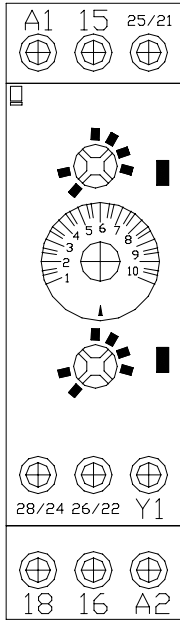

Delay Timer
05945-011-65-44

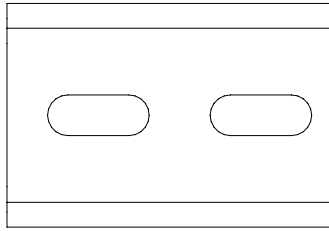

2" Din Rail
05700-002-36-09

**FAN LOAD ON TIMER OUTPUT
5A, 1/4HP, 240 V AC MAX**

Decal, Fan Load
09905-003-32-20

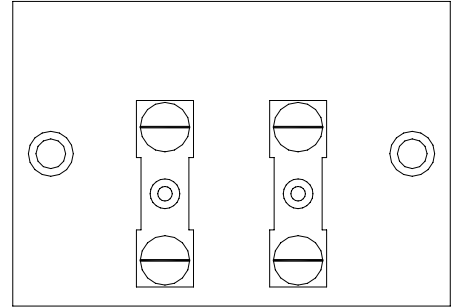

Terminal Board
05940-011-84-41

Kit, Exhaust Fan - Electric & Steam Models
05700-031-90-53

Kit, Exhaust Fan - Gas Models
05700-003-14-59

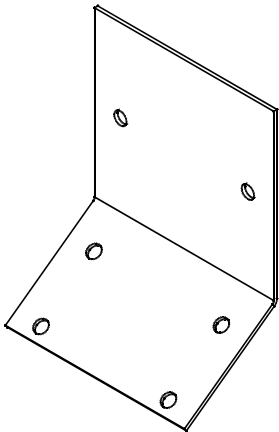

Whisker Limit Switch
Mounting Bracket
05700-000-14-55

Whisker Switch Assembly
05700-002-23-94

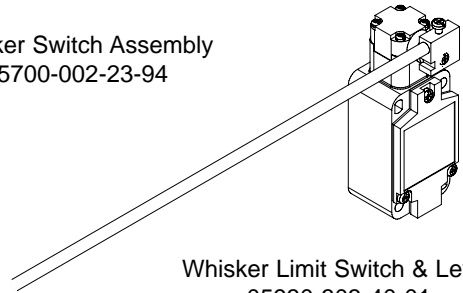

Whisker Limit Switch & Lever
05930-303-40-01

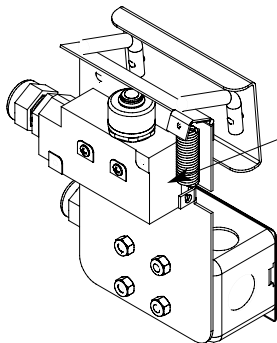

Limit Switch
05930-002-62-81

Striker Plate Limit Switch
Assembly
05700-002-62-94

Proximity Limit
Switch Sensor
06685-002-94-15

Bracket, Proximity Switch
05700-002-94-93

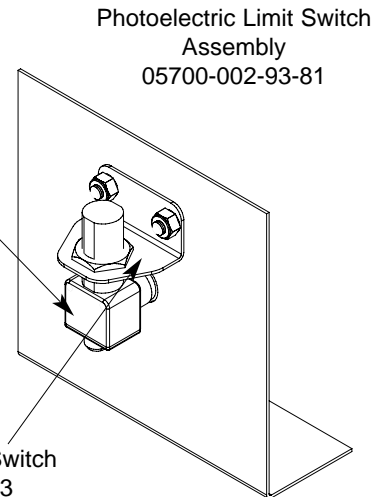

Photoelectric Limit Switch
Assembly
05700-002-93-81

SECTION 6: PARTS SECTION

SIDE LOADER TRACK ASSEMBLY/LEG REPLACEMENTS/STRAINER

**Side loader track assembly
(left to right model shown).**

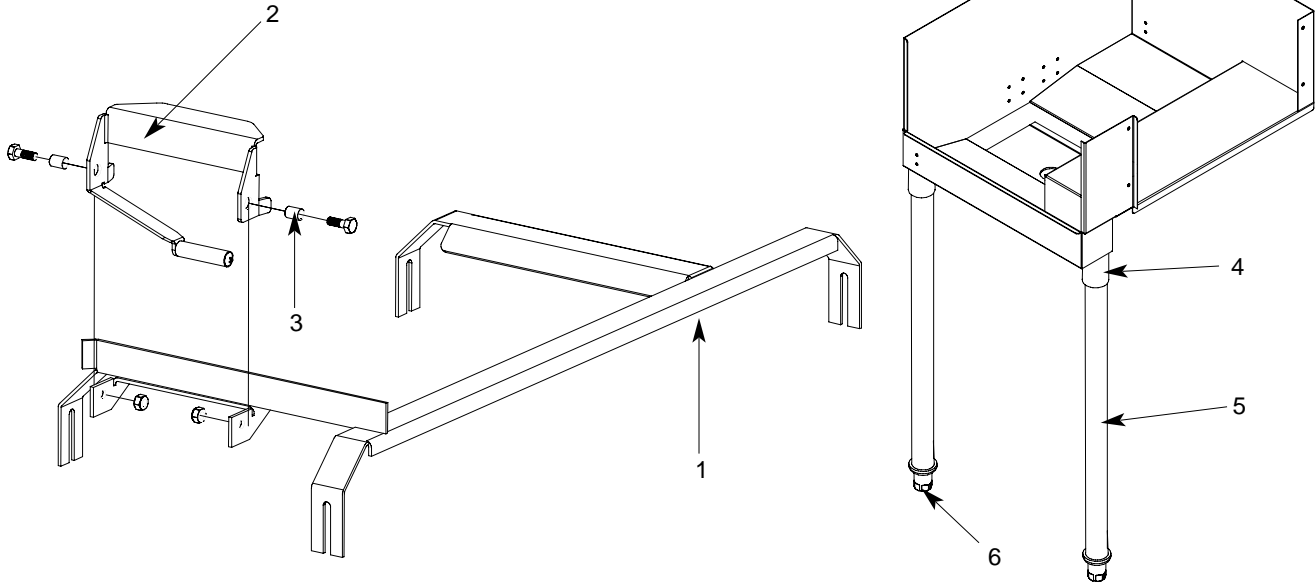

ITEM	QTY	DESCRIPTION	Mfg. No.
1	1	Track Weldment (Left to Right) 24"	05700-031-78-98
	1	Track Weldment (Right to Left) 24"	05700-031-95-20
	1	Track Weldment (Left to Right) 30"	05700-003-04-57
	1	Track Weldment (Right to Left) 30"	05700-003-04-58
2	1	Actuator Switch Replacement Kit	06401-003-10-64
3	2	Spacer	05700-011-71-44
4	1	Leg Socket Replacement Kit	06401-003-09-79
5	1	Leg Support Replacement Kit	06401-003-09-80
6	1	Bullet Foot	05340-108-01-03

Replacement Kits Notes:

The actuator switch replacement kit comes with the actuator weldment, mounting hardware and (2) spacers.

The leg socket replacement kit has the leg socket, mounting hardware and set screw.

The leg support replacement kit has the leg and the bullet foot included.

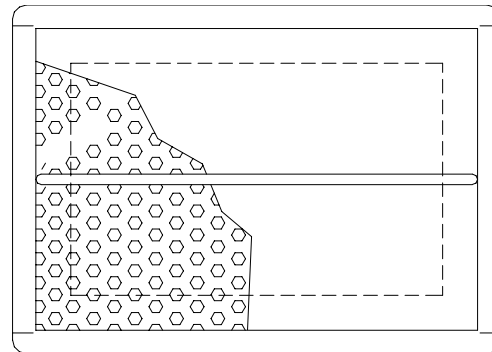

**Front Strainer Weldment
05700-021-85-10**

SECTION 6: PARTS SECTION

SIDE LOADER PAWL BAR ASSEMBLIES/PAWL BAR BRACKET/MAGNET

Replacement Kit Note:
The kits for the pawl bars come with the bar weldment, (3) dogs and the hardware.

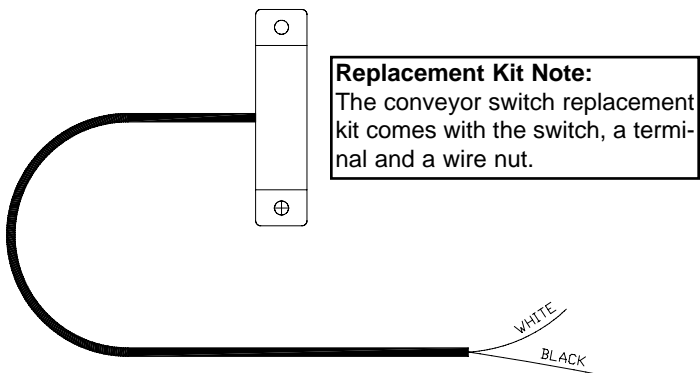
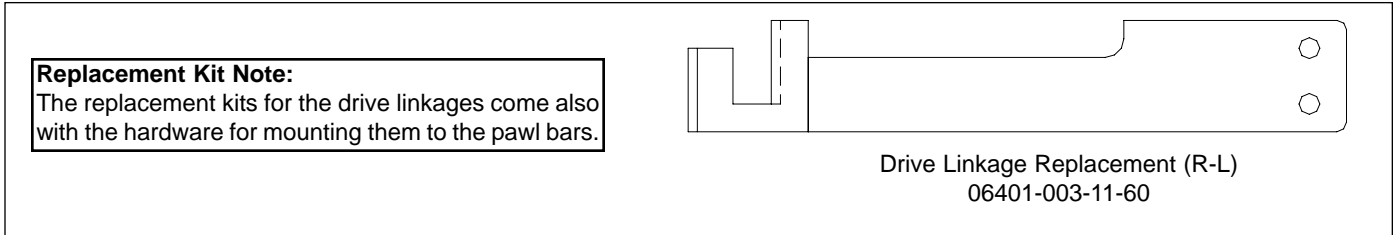
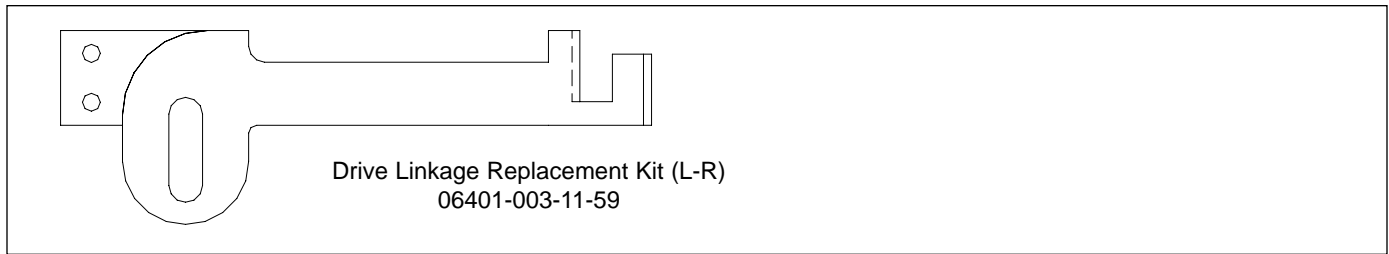
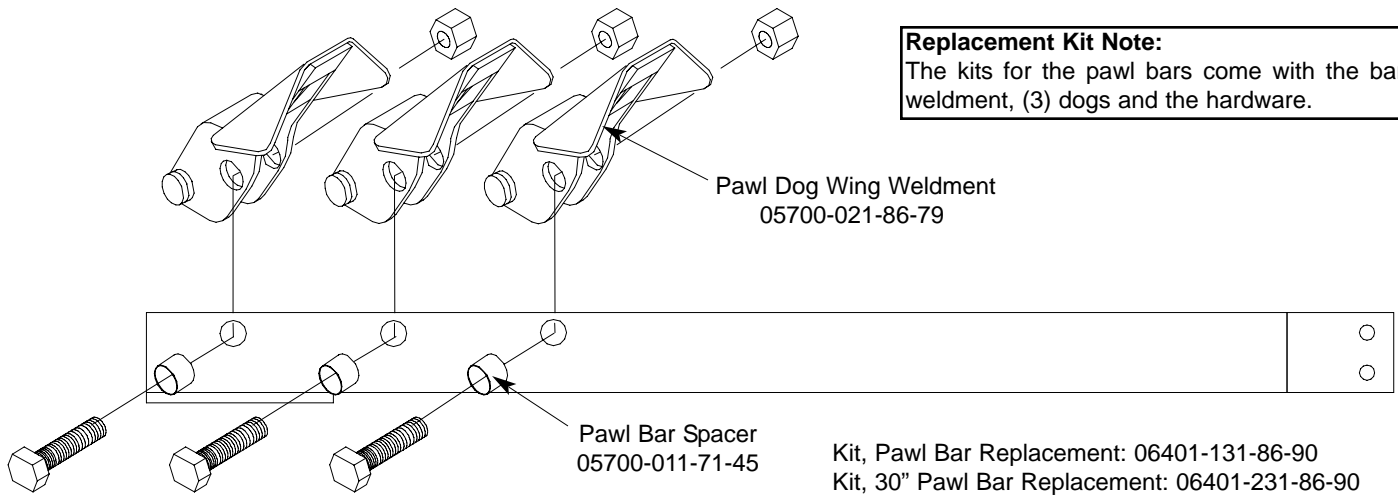

Service Note:
The cord for the conveyor switch needs to be cut to length in the field and have the pink terminal applied there.

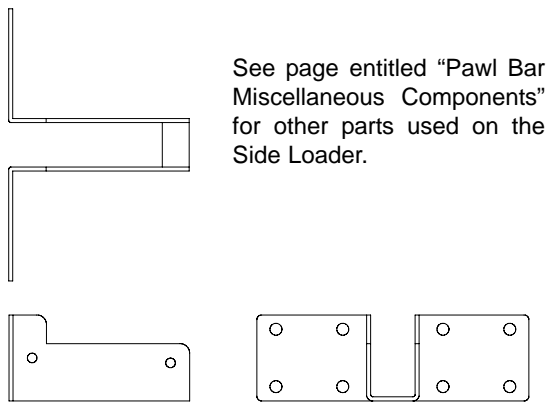

Pawl Bar Roller Bracket
05700-031-77-94

SECTION 6: PARTS SECTION
SIDE LOADER VENT COWL OPTION

Vent Cowl Replacement Kit (Left to Right)
 06401-003-11-81

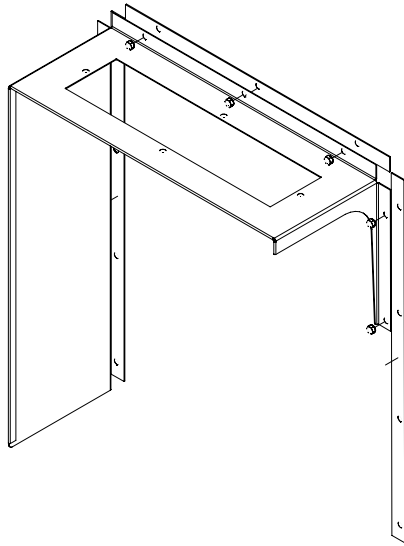

Vent Cowl Replacement Kit (Right to Left)
 06401-003-11-83

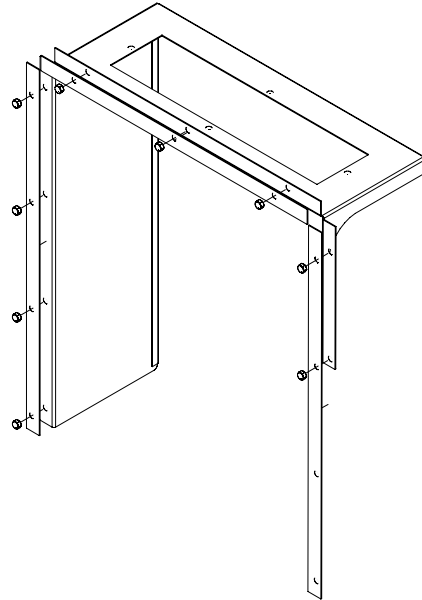

Service Note:
 One of the side gaskets that come in the kit will need to be cut to length in order to fit properly on the unit when replaced.

Replacement Kit Note:
 The replacement kit(s) for the vent cowls come with the cowls, the gaskets and mounting hardware.

Vent Cowl Gasket, Top: 05330-031-83-47
 Vent Cowl Gasket, Side: 05330-031-83-48

VENT SCOOP OPTION
 Vent Scoop Assembly
 05700-002-04-08

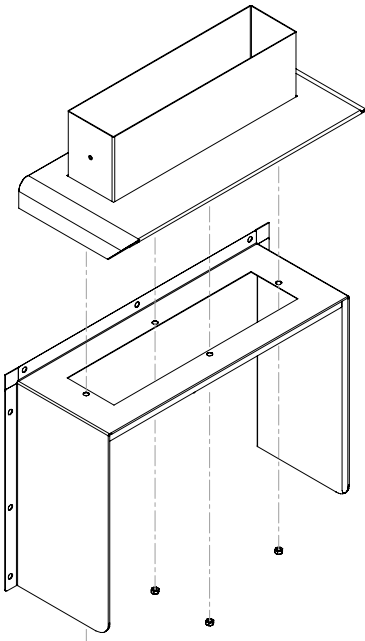

STANDARD ASSEMBLY
 Vent Cowl Cover Replacement Kit
 06401-003-10-16

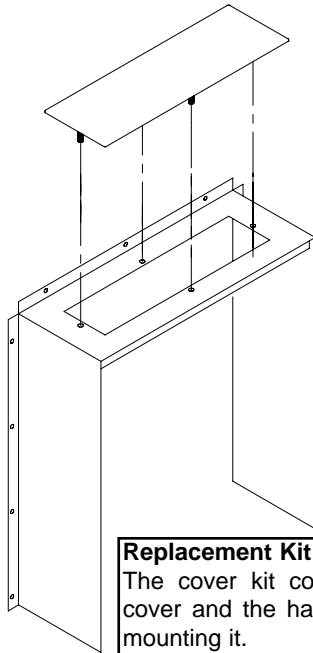

Replacement Kit Note:
 The cover kit contains the cover and the hardware for mounting it.

Vent Cowl Assembly for Hooded Side Loader Option
 05700-003-15-66

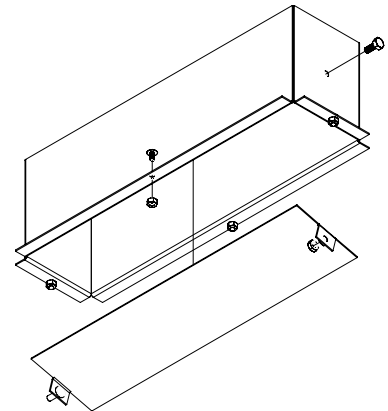

SECTION 6: PARTS SECTION
D226 STEAM BOOSTER CONTROL BOX ASSEMBLY

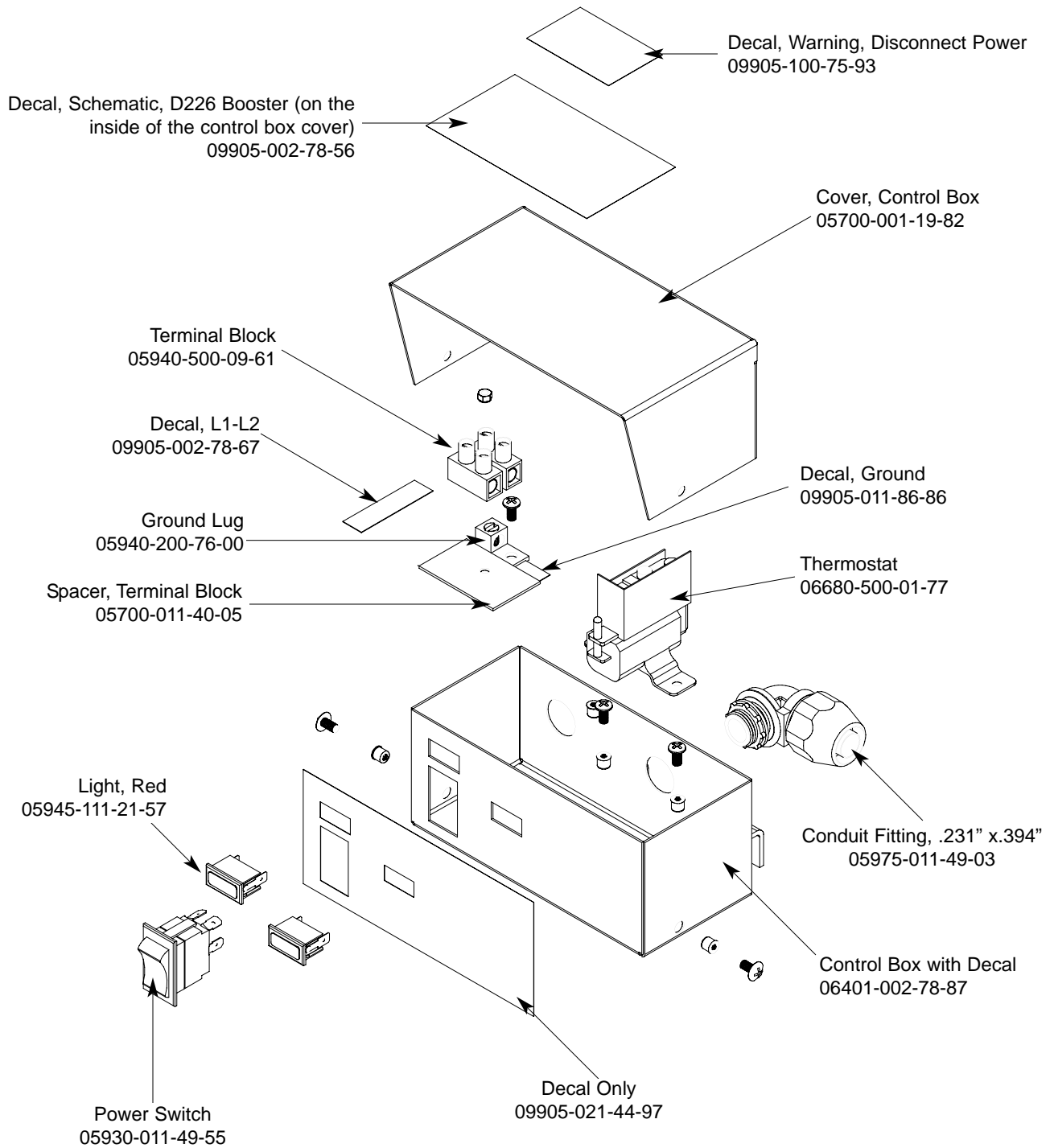

SECTION 6: PARTS SECTION
D226 STEAM BOOSTER PLUMBING ASSEMBLY

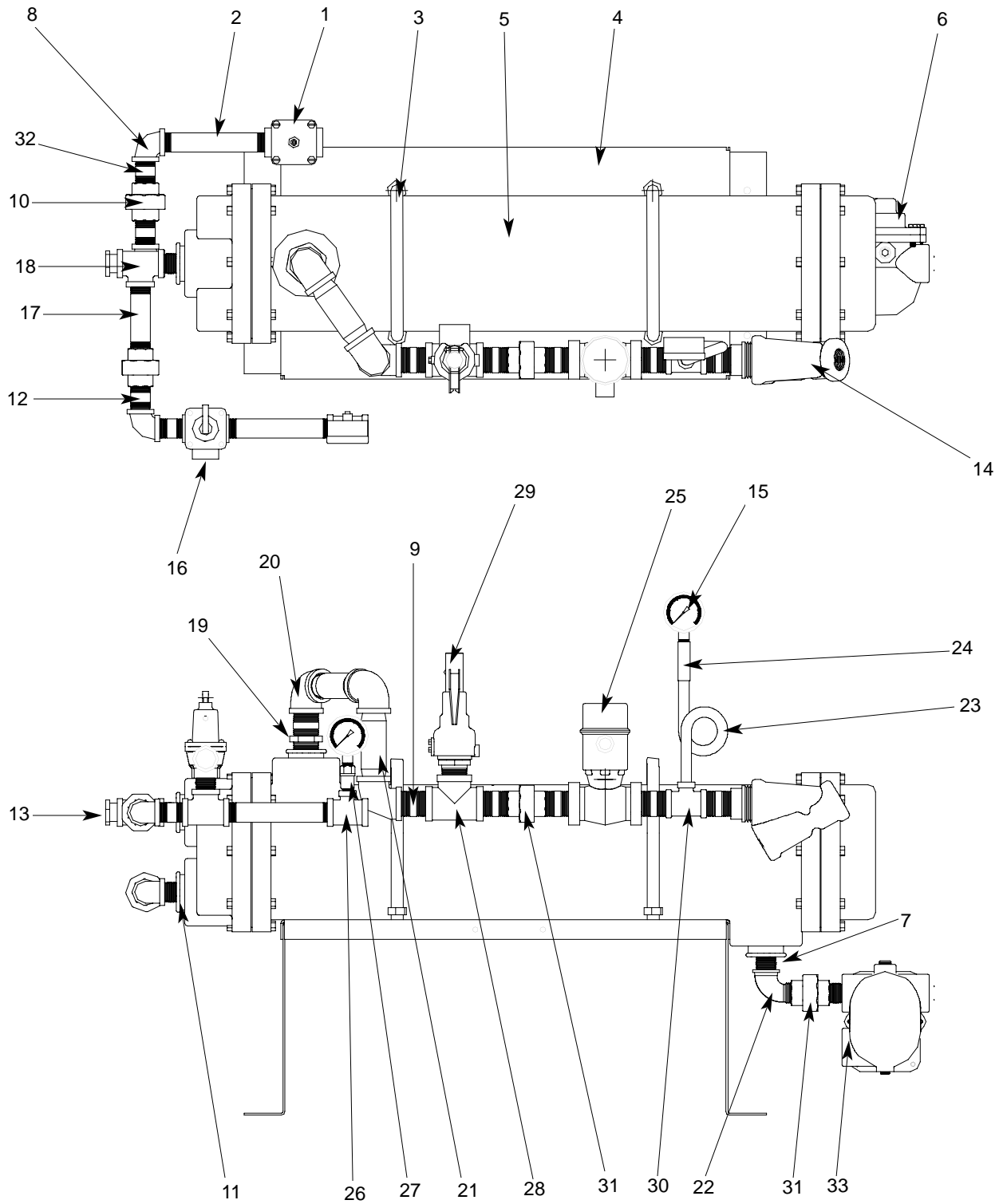

SECTION 6: PARTS SECTION**D226 STEAM BOOSTER PLUMBING ASSEMBLY (CONTINUED)**

ITEM	QTY	DESCRIPTION	Mfg. No.
1	1	Water Pressure Regulator, 3/4"	04820-100-01-06
2	2	Nipple, Brass, 3/4" NPT x 6" Long	05700-001-26-74
3	2	U-Bolt, 6", 5/8"-11 Thread	5306-458-01-04
4	1	Platform Weldment	05700-002-78-02
5	1	Heat Exchanger	4420-100-01-05
6	1	Steam Trap, 3/4"	06680-500-02-77
7	1	Bushing, 2" NPT x 3/4" NPT, Black Iron	04730-902-06-34
8	2	Elbow, 3/4" NPT, Brass	04730-206-13-00
9	6	Nipple, 1" NPT, Close, Black Iron	04730-907-08-34
10	2	Union, 3/4" NPT, Brass	04730-212-05-00
11	2	Bushing, 2" NPT x 3/4" NPT, Brass	04730-202-18-00
12	4	Nipple, 3/4" NPT x 1-3/8" Long	04730-207-34-00
13	1	Bushing, Hex 3/4" M x 1/2" F, Brass	04730-002-56-27
14	1	Y-Strainer, 1" NPT, Black Iron	04730-217-02-32
15	2	Pressure Gauge	06685-111-88-34
16	1	Steam Relief Valve	04820-100-07-06
17	2	Nipple, 3/4" NPT x 4" Long, Brass	04730-207-05-00
18	2	Tee, 3/4" NPT x 3/4" NPT x 3/4" NPT, Brass	04730-211-01-34
19	1	Bushing, 2" NPT x 1" NPT, Black Iron	04730-002-94-51
20	3	Elbow, 90°, 1" NPT, Black Iron	04730-906-03-34
21	2	Nipple, 1" NPT x 4" Long, Black Iron	04730-907-09-34
22	1	Elbow, 90°, Street, 3/4" NPT, Black Iron	04730-011-87-37
23	1	Nipple, Pigtail, 1/4" NPT	04730-907-14-34
24	1	Coupling, 1/4" NPT x 1/4" NPT	04730-904-01-34
25	1	Steam Solenoid Valve, 240VA	04820-100-29-34
25	1	Steam Solenoid Valve, 200VA	04820-002-93-66
25	1	Steam Solenoid Valve (ASCO)	04820-002-90-26
26	1	Tee, 3/4" NPT x 3/4" NPT x 1/4" NPT, Brass	04730-211-04-00
27	1	Valve, Test Cock, 1/4" NPT	04810-011-72-67
28	1	Tee, 1" NPT x 1" NPT x 1" NPT, Black Iron	04730-911-01-34
29	1	Valve, Safety Relief 1" NPT	04820-100-01-35
30	1	Tee, 1" NPT x 1" NPT x 1/4" NPT, Black Iron	04730-911-01-00
31	2	Union, 3/4" NPT, Black Iron	04730-912-01-00
32	2	Nipple, 3/4" NPT x 2" Long, Brass	04730-207-46-00
33	2	Nipple, 3/4" NPT, Close, Black Iron	04730-907-01-00

SECTION 6: PARTS SECTION

GO*BOX COMPONENTS

A GO*BOX is a kit of the most needed parts for a particular model or model family to successfully effect a repair in the first call 90% or more of the time.

The following components may be ordered together using part number 06401-002-14-98.

QTY	DESCRIPTION	Mfg. No.
1	Drive Motor Contactor	05945-111-68-38
1	Contactor, Wash Heater, 3 ph, 3 pole	05945-002-24-70
1	Contactor, Wash Heater, 1 ph, 4 pole	05945-111-68-37
2	Final Rinse Arm End Cap	05700-011-35-92
1	Float Switch, Dual, Wash & Prewash	06680-121-70-71
1	Gasket, Pawl Bar Gutter	05330-011-68-55
1	Gauge, Pressure	06685-111-88-34
6	Glide, Door Edge	05700-111-70-92
2	Magnet, Door Reed Switch	05930-111-51-68
2	O Ring, Prewash Manifold	05330-400-12-08
2	O Ring, Wash Manifold	05330-011-74-56
1	Overload, Drive Motor	05945-111-68-39
1	Overload, Wash Motor	05945-111-68-40
1	Relay,120v, 3 PDT	05945-111-72-51
1	Relay,120v,50/60Hz 3A Control	05945-111-35-19
1	Repair Kit, 3/4" Vacuum Breaker	04820-001-60-57
4	Roller, Pawl Bar	05700-011-68-16
1	Seal Kit for Wash and Prewash pump	05330-011-71-98
2	Solenoid Valve, Fill & Rinse	04810-100-53-00
2	Switch, Power	05930-011-49-55
2	Switch, Reed, Actuator (NC)	05930-111-68-44
1	Switch, Reed, Door (NO)	05930-111-68-86
1	Thermometer, 48" Capillary	06685-111-68-48
1	Thermometer, 96" Capillary	06685-111-68-49
2	Thermostat, Wash High Limit	05930-121-71-36
2	Thermostat, Wash Regulating	05930-121-67-72
1	Transformer,150VA	05950-011-68-35
1	Valve, Ball 1 1/2" NPT	04820-111-71-46

SECTION 6: PARTS SECTION

RINSE FILL OPTION

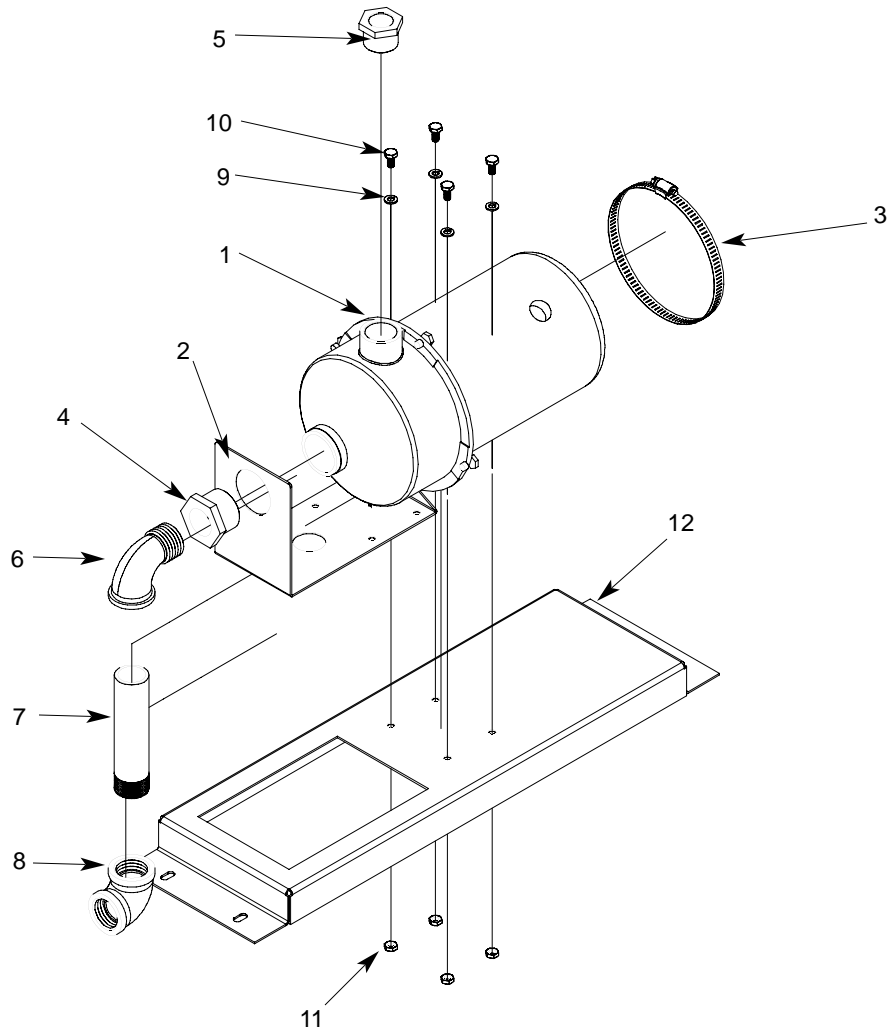

ITEM	QTY	DESCRIPTION	Mfg. No.
	1	Rinse Fill Motor Assembly	05700-002-40-25
1	1	Motor	06105-002-72-71
2	1	Bracket, Pump Mounting	05700-002-63-59
3	1	Clamp, Hose 5 5/8" to 6"	04730-011-34-90
4	1	Reducer Bushing, 1 1/4" to 1"	04730-002-73-62
5	1	Reducer Bushing 1" to 3/4"	04730-011-65-14
6	1	Elbow, 90 Deg., 1" Street	04730-002-11-99
7	1	Nipple, 1" NPT x 6" Long Brass	04730-002-12-00
8	1	Elbow, 90 Deg. Brass Female	04730-002-12-55
9	4	Lockwasher, 1/4"	05311-274-01-00
10	4	Bolt, 1/4"-20 x 1/2" Long	05305-274-02-00
11	4	Nut, Hex S/S 1/4"-20	05310-274-01-00
12	1	Rinse Motor Mounting Bracket	05700-002-38-90

SECTION 7: ELECTRICAL SCHEMATICS

SECTION 7: ELECTRICAL SCHEMATICS

AJ-54CE (208-230 VOLT, 60 HZ, SINGLE PHASE)

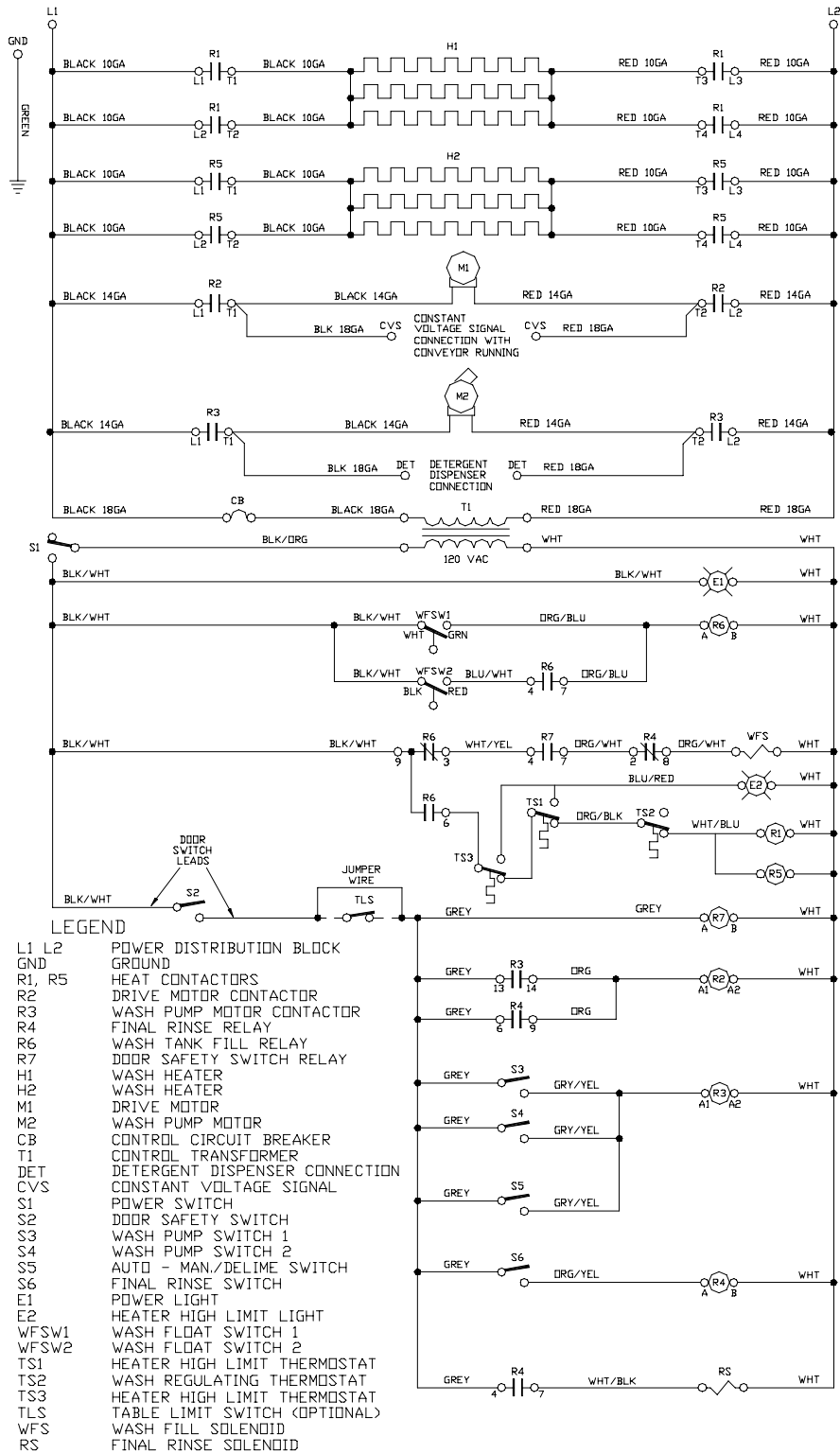

09905-002-12-70

SECTION 7: ELECTRICAL SCHEMATICS

AJ-54CE (208-230 VOLT, 60 HZ, THREE PHASE)

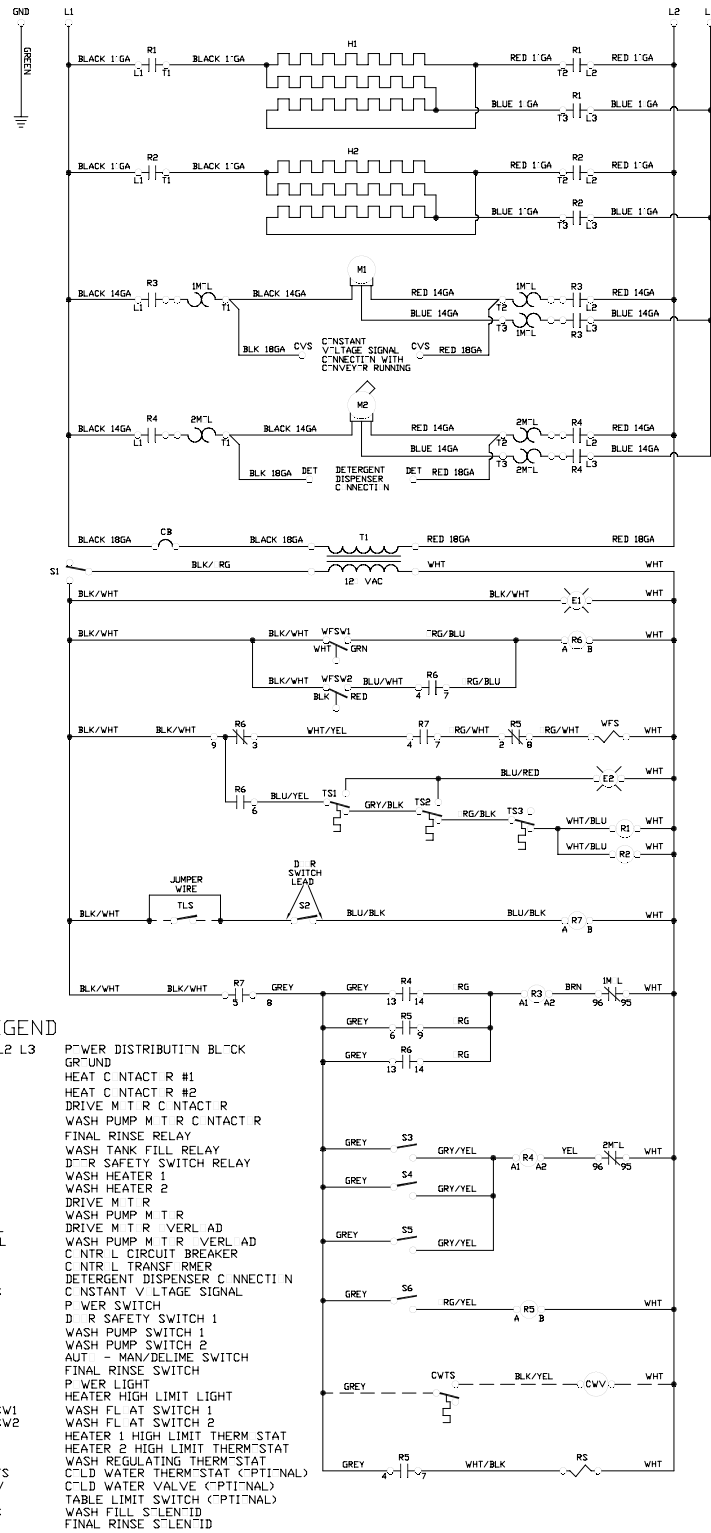

99'5-'31-91-7'

SECTION 7: ELECTRICAL SCHEMATICS

AJ-54CE (460-575-600 VOLT, 60 HZ, THREE PHASE)

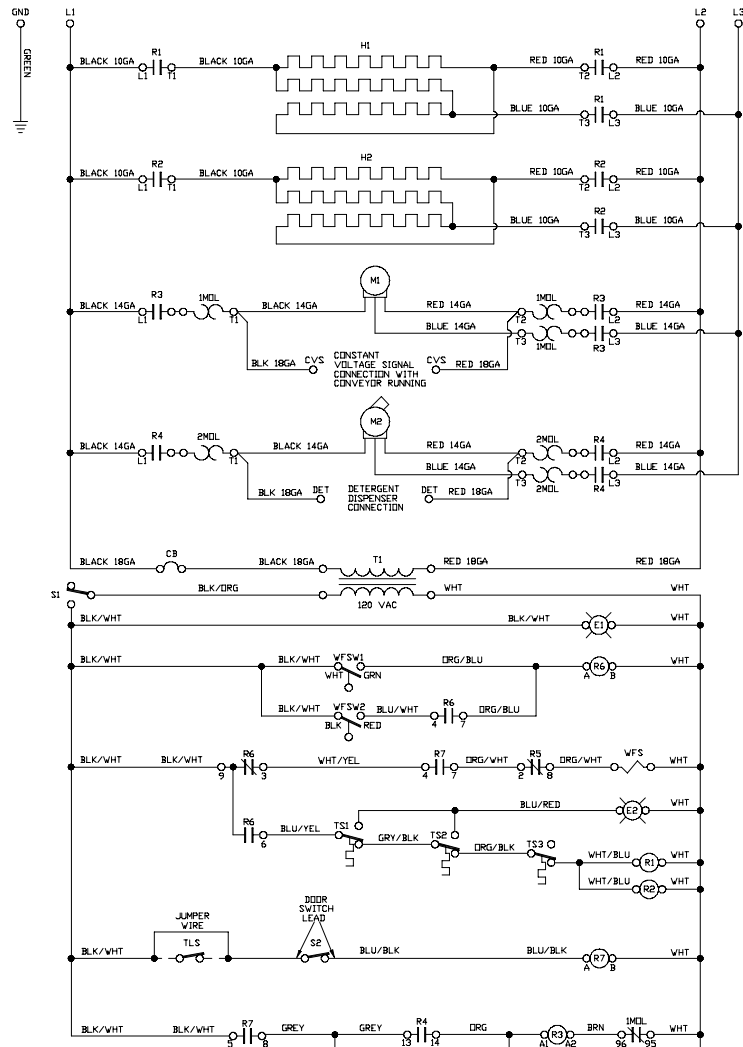

LEGEND

- | | |
|----------|----------------------------------|
| L1 L2 L3 | POWER DISTRIBUTION BLOCK |
| GND | GROUND |
| R1 | HEAT CONTACTOR #1 |
| R2 | HEAT CONTACTOR #2 |
| R3 | DRIVE MOTOR CONTACTOR |
| R4 | WASH PUMP MOTOR CONTACTOR |
| R5 | FINAL RINSE RELAY |
| R6 | WASH TANK FILL RELAY |
| R7 | DDDR SAFETY SWITCH RELAY |
| H1 | WASH HEATER 1 |
| H2 | WASH HEATER 2 |
| M1 | DRIVE MOTOR |
| M2 | WASH PUMP MOTOR |
| 1MDL | DRIVE MOTOR OVERLOAD |
| 2MDL | WASH PUMP MOTOR OVERLOAD |
| CB | CONTROL CIRCUIT BREAKER |
| T1 | CONTROL TRANSFORMER |
| DET | DETERGENT DISPENSER CONNECTION |
| CVS | CONSTANT VOLTAGE SIGNAL |
| S1 | POWER SWITCH |
| S2 | DDDR SAFETY SWITCH 1 |
| S3 | WASH PUMP SWITCH 1 |
| S4 | WASH PUMP SWITCH 2 |
| S5 | AUTO - MAN/DELIME SWITCH |
| S6 | FINAL RINSE SWITCH |
| E1 | POWER LIGHT |
| E2 | HEATER HIGH LIMIT LIGHT |
| WFSW1 | WASH FLOAT SWITCH 1 |
| WFSW2 | WASH FLOAT SWITCH 2 |
| TS1 | HEATER 1 HIGH LIMIT THERMISTAT |
| TS2 | HEATER 2 HIGH LIMIT THERMISTAT |
| TS3 | WASH REGULATING THERMISTAT |
| CWTS | COLD WATER THERMISTAT (OPTIONAL) |
| CWV | COLD WATER VALVE (OPTIONAL) |
| TLS | TABLE LIMIT SWITCH (OPTIONAL) |
| WFS | WASH FILL SOLENOID |
| RS | FINAL RINSE SOLENOID |

09905-031-95-56

SECTION 7: ELECTRICAL SCHEMATICS

AJ-54CS (208-230 VOLT, 60 HZ, SINGLE PHASE)

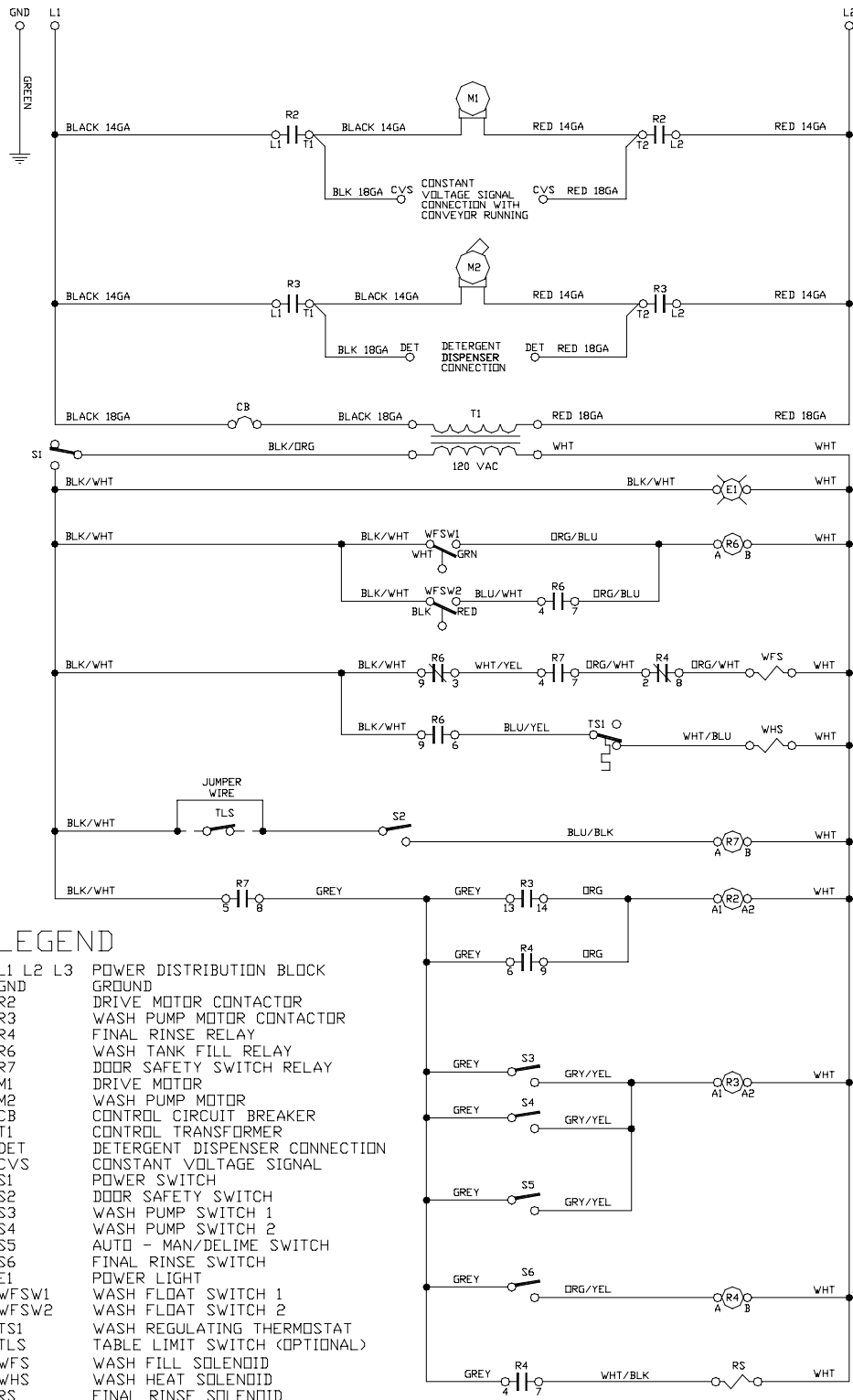

9905-031-80-23a

SECTION 7: ELECTRICAL SCHEMATICS

AJ-54CS (208-230 VOLT, 60 HZ, THREE PHASE)

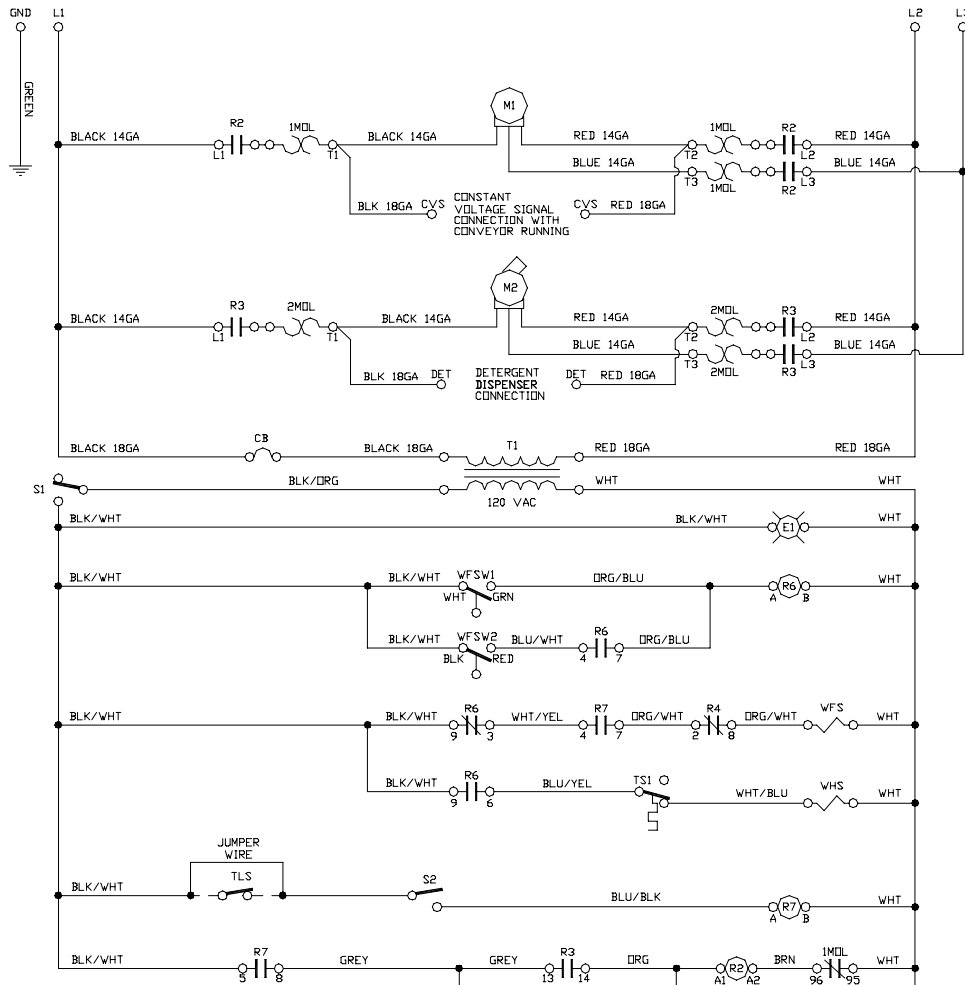

LEGEND

- L1 L2 L3 POWER DISTRIBUTION BLOCK
- GND GROUND
- R2 DRIVE MOTOR CONTACTOR
- R3 WASH PUMP MOTOR CONTACTOR
- R4 FINAL RINSE RELAY
- R6 WASH TANK FILL RELAY
- R7 DOOR SAFETY SWITCH RELAY
- M1 DRIVE MOTOR
- M2 WASH PUMP MOTOR
- 1MDL DRIVE MOTOR OVERLOAD
- 2MDL WASH PUMP MOTOR OVERLOAD
- CB CONTROL CIRCUIT BREAKER
- T1 CONTROL TRANSFORMER
- DET DETERGENT DISPENSER CONNECTION
- CVS CONSTANT VOLTAGE SIGNAL
- S1 POWER SWITCH
- S2 DOOR SAFETY SWITCH
- S3 WASH PUMP SWITCH 1
- S4 WASH PUMP SWITCH 2
- S5 AUTO - MAN/DELIME SWITCH
- S6 FINAL RINSE SWITCH
- E1 POWER LIGHT
- WFSW1 WASH FLOAT SWITCH 1
- WFSW2 WASH FLOAT SWITCH 2
- TS1 WASH REGULATING THERMOSTAT
- TLS TABLE LIMIT SWITCH (OPTIONAL)
- WFS WASH FILL SOLENOID
- WWS WASH HEAT SOLENOID
- RS FINAL RINSE SOLENOID

9905-031-80-24

SECTION 7: ELECTRICAL SCHEMATICS

AJ-54CS (460-575-600 VOLT, 60 HZ, THREE PHASE)

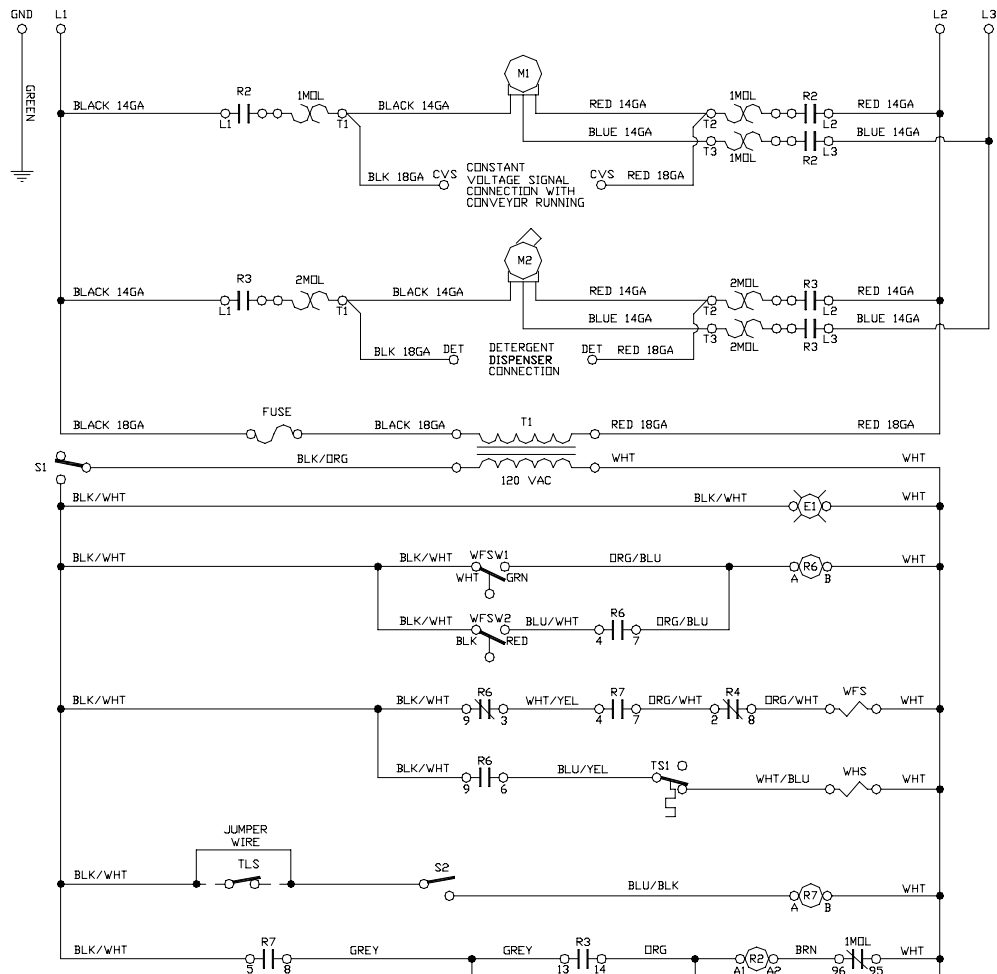

LEGEND

- L1 L2 L3 POWER DISTRIBUTION BLOCK
- GND GROUND
- R2 DRIVE MOTOR CONTACTOR
- R3 WASH PUMP MOTOR CONTACTOR
- R4 FINAL RINSE RELAY
- R6 WASH TANK FILL RELAY
- R7 DOOR SAFETY SWITCH RELAY
- M1 DRIVE MOTOR
- M2 WASH PUMP MOTOR
- 1MDL DRIVE MOTOR OVERLOAD
- 2MDL WASH PUMP MOTOR OVERLOAD
- FUSE CONTROL FUSE
- T1 CONTROL TRANSFORMER
- DET DETERGENT DISPENSER CONNECTION
- CVS CONSTANT VOLTAGE SIGNAL
- S1 POWER SWITCH
- S2 DOOR SAFETY SWITCH
- S3 WASH PUMP SWITCH 1
- S4 WASH PUMP SWITCH 2
- S5 AUTO - MAN/DELIME SWITCH
- S6 FINAL RINSE SWITCH
- E1 POWER LIGHT
- WFSW1 WASH FLOAT SWITCH 1
- WFSW2 WASH FLOAT SWITCH 2
- TS1 WASH REGULATING THERMOSTAT
- TLS TABLE LIMIT SWITCH (OPTIONAL)
- WFS WASH FILL SOLENOID
- WHS WASH HEAT SOLENOID
- RS FINAL RINSE SOLENOID

9905-031-80-26

SECTION 7: ELECTRICAL SCHEMATICS

AJ-76CE & AJ-90CE (208-230 VOLT, 60 HZ, SINGLE PHASE)

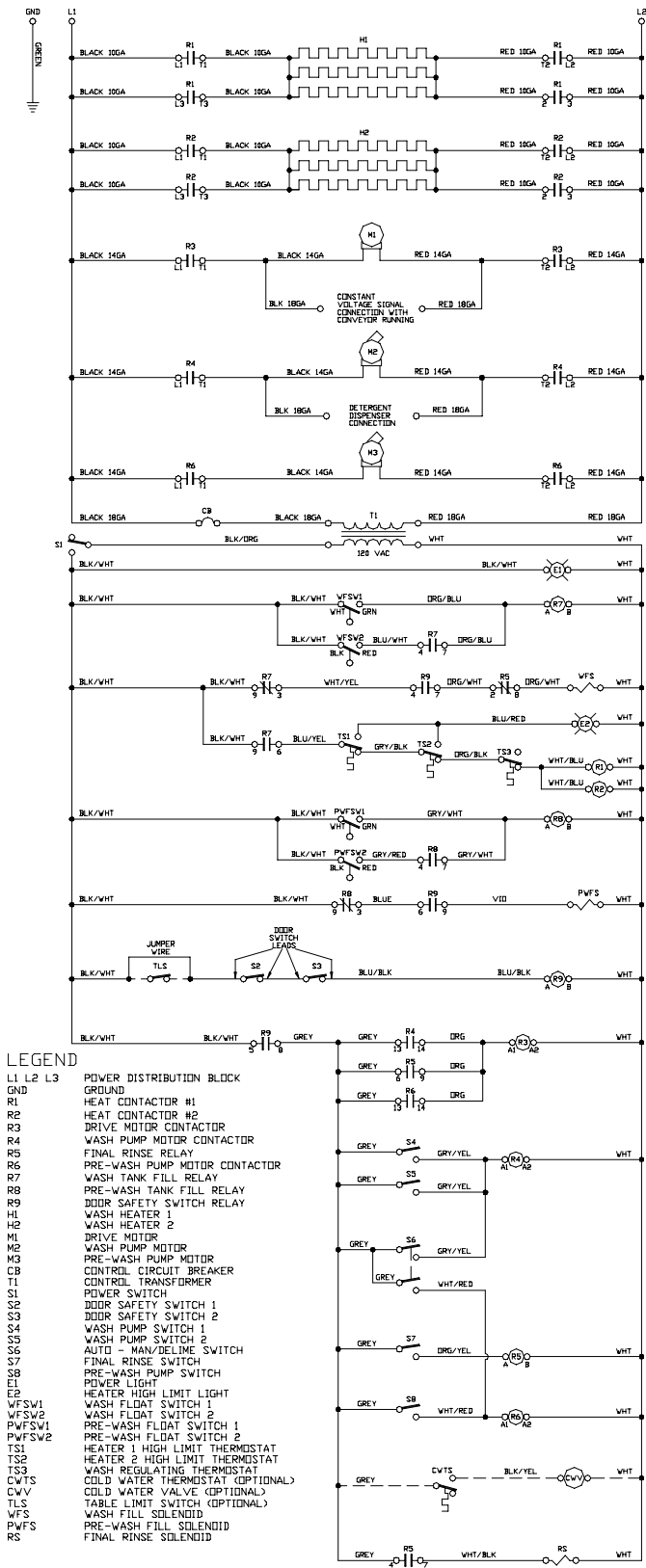

- LEGEND**
- L1 L2 L3 POWER DISTRIBUTION BLOCK
 - GND GROUND
 - R1 HEAT CONTACTOR #1
 - R2 HEAT CONTACTOR #2
 - R3 DRIVE MOTOR CONTACTOR
 - R4 WASH PUMP MOTOR CONTACTOR
 - R5 FINAL RINSE RELAY
 - R6 PRE-WASH PUMP MOTOR CONTACTOR
 - R7 WASH TANK FILL RELAY
 - R8 PRE-WASH TANK FILL RELAY
 - R9 DDDR SAFETY SWITCH RELAY
 - H1 WASH HEATER 1
 - H2 WASH HEATER 2
 - M1 DRIVE MOTOR
 - M2 WASH PUMP MOTOR
 - M3 PRE-WASH PUMP MOTOR
 - CB CONTROL CIRCUIT BREAKER
 - T1 CONTROL TRANSFORMER
 - S1 POWER SWITCH
 - S2 DDDR SAFETY SWITCH 1
 - S3 DDDR SAFETY SWITCH 2
 - S4 WASH PUMP SWITCH 1
 - S5 WASH PUMP SWITCH 2
 - S6 AUTO - MAN/DELIME SWITCH
 - S7 FINAL RINSE SWITCH
 - S8 PRE-WASH PUMP SWITCH
 - E1 POWER LIGHT
 - E2 HEATER HIGH LIMIT LIGHT
 - WFSW1 WASH FLDAT SWITCH 1
 - WFSW2 WASH FLDAT SWITCH 2
 - PWFSW1 PRE-WASH FLDAT SWITCH 1
 - PWFSW2 PRE-WASH FLDAT SWITCH 2
 - TS1 HEATER 1 HIGH LIMIT THERMOSTAT
 - TS2 HEATER 2 HIGH LIMIT THERMOSTAT
 - TS3 WASH REGULATING THERMISTAT
 - CWTS COLD WATER THERMISTAT (OPTIONAL)
 - CWV COLD WATER VALVE (OPTIONAL)
 - TL5 TABLE LIMIT SWITCH (OPTIONAL)
 - VFS WASH FILL SOLENOID
 - PWFS PRE-WASH FILL SOLENOID
 - RS FINAL RINSE SOLENOID

09905-031-80-35

SECTION 7: ELECTRICAL SCHEMATICS

AJ-76CE & AJ-90CE (208-230 VOLT, 60 HZ, THREE PHASE)

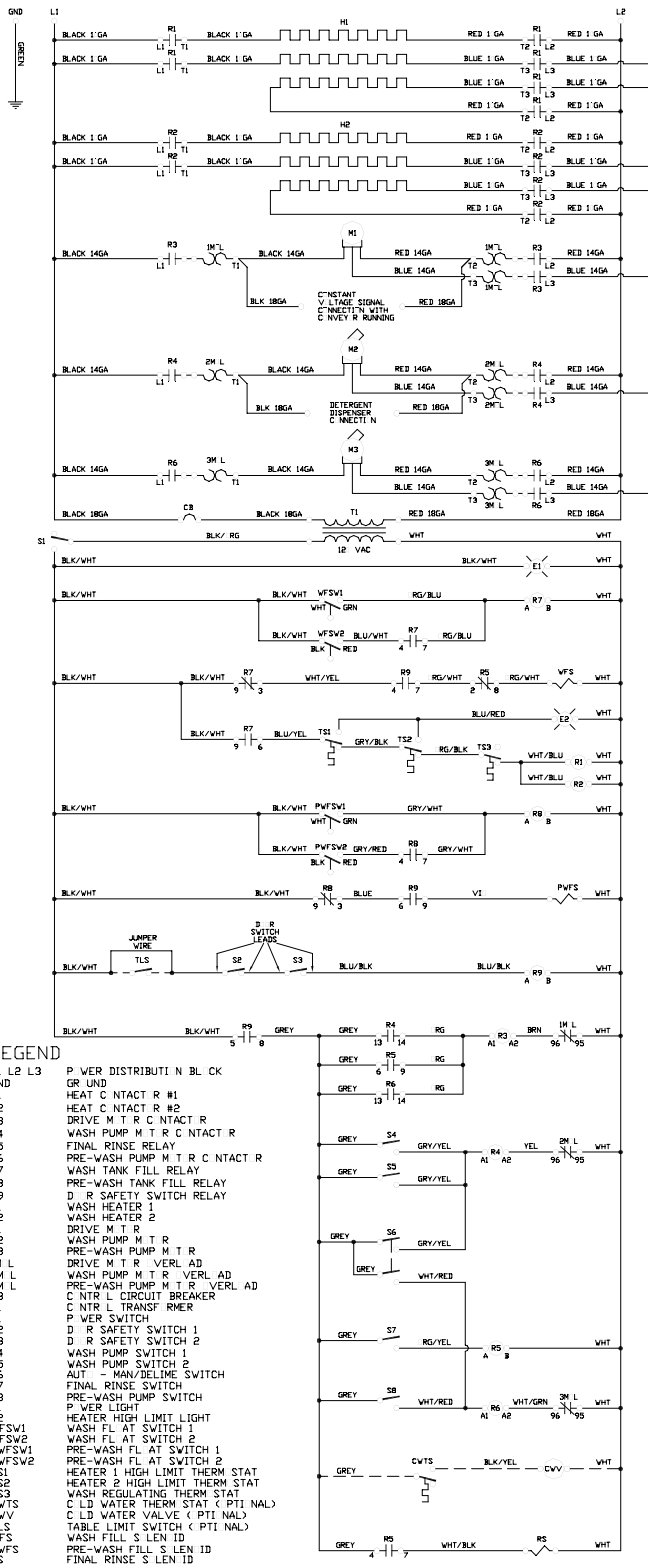

99 5-31-91-69

SECTION 7: ELECTRICAL SCHEMATICS

AJ-76CE & AJ-90CE (460-575-600 VOLT, 60 HZ, THREE PHASE)

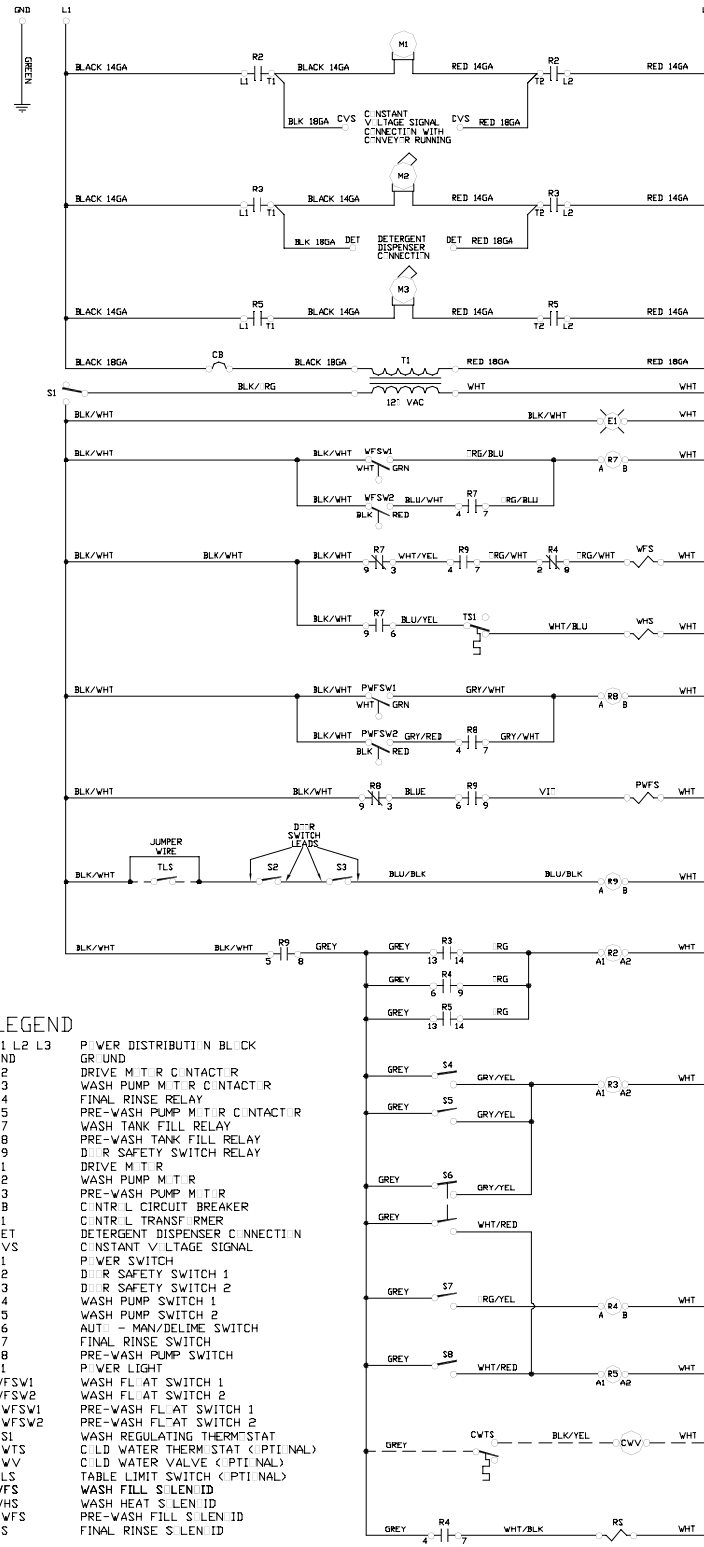

99-5-31-8-35

SECTION 7: ELECTRICAL SCHEMATICS

AJ-76CS & AJ-90CS (208-230 VOLT, 60 HZ, SINGLE PHASE)

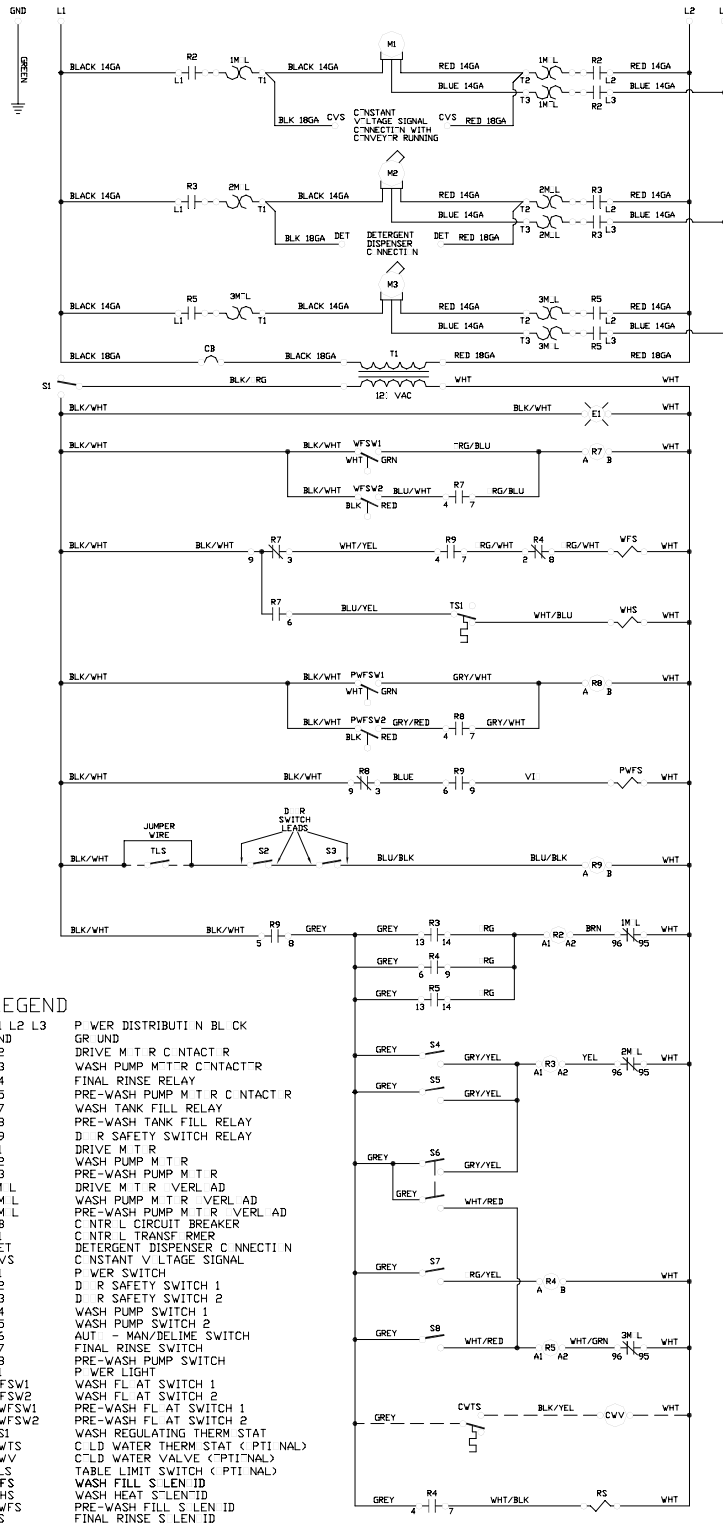

- LEGEND**
- L1 L2 L3 POWER DISTRIBUTION BLK CK
 - GND GR UNB
 - R2 DRIVE MOTOR CONTACTOR
 - R3 WASH PUMP MOTOR CONTACTOR
 - R4 FINAL RINSE RELAY
 - R5 PRE-WASH PUMP MOTOR CONTACTOR
 - R7 WASH TANK FILL RELAY
 - R8 PRE-WASH TANK FILL RELAY
 - R9 D R SAFETY SWITCH RELAY
 - M1 DRIVE MOTOR
 - M2 WASH PUMP MOTOR
 - M3 PRE-WASH PUMP MOTOR
 - IM L DRIVE MOTOR VERL AD
 - 2M L WASH PUMP MOTOR VERL AD
 - 3M L PRE-WASH PUMP MOTOR VERL AD
 - CNTL C NTR L CIRCUIT BREAKER
 - DET DETERGENT DISPENSER CONNECTION
 - CVS CONSTANT VOLTAGE SIGNAL
 - S1 POWER SWITCH
 - S2 D R SAFETY SWITCH 1
 - S3 D R SAFETY SWITCH 2
 - S4 WASH PUMP SWITCH 1
 - S5 WASH PUMP SWITCH 2
 - S6 AUT - MAN/DELIME SWITCH
 - S7 FINAL RINSE SWITCH
 - S8 PRE-WASH PUMP SWITCH
 - E1 POWER LIGHT
 - WFSW1 WASH FLAT SWITCH 1
 - WFSW2 WASH FLAT SWITCH 2
 - PWFSW1 PRE-WASH FLAT SWITCH 1
 - PWFSW2 PRE-WASH FLAT SWITCH 2
 - TS1 WASH REGULATING THERM STAT
 - CVTS C L D WATER THERM STAT (PTI NAL)
 - CVW C L D WATER VALVE (PTI NAL)
 - TLS TABLE LIMIT SWITCH (PTI NAL)
 - WFS WASH FILL S LEN ID
 - WHS WASH HEAT S LEN ID
 - PWFS PRE-WASH FILL S LEN ID
 - RS FINAL RINSE S LEN ID

99 5- 31-8 -36

SECTION 7: ELECTRICAL SCHEMATICS

AJ-76CS & AJ-90CS (208-230 VOLT, 60 HZ, THREE PHASE)

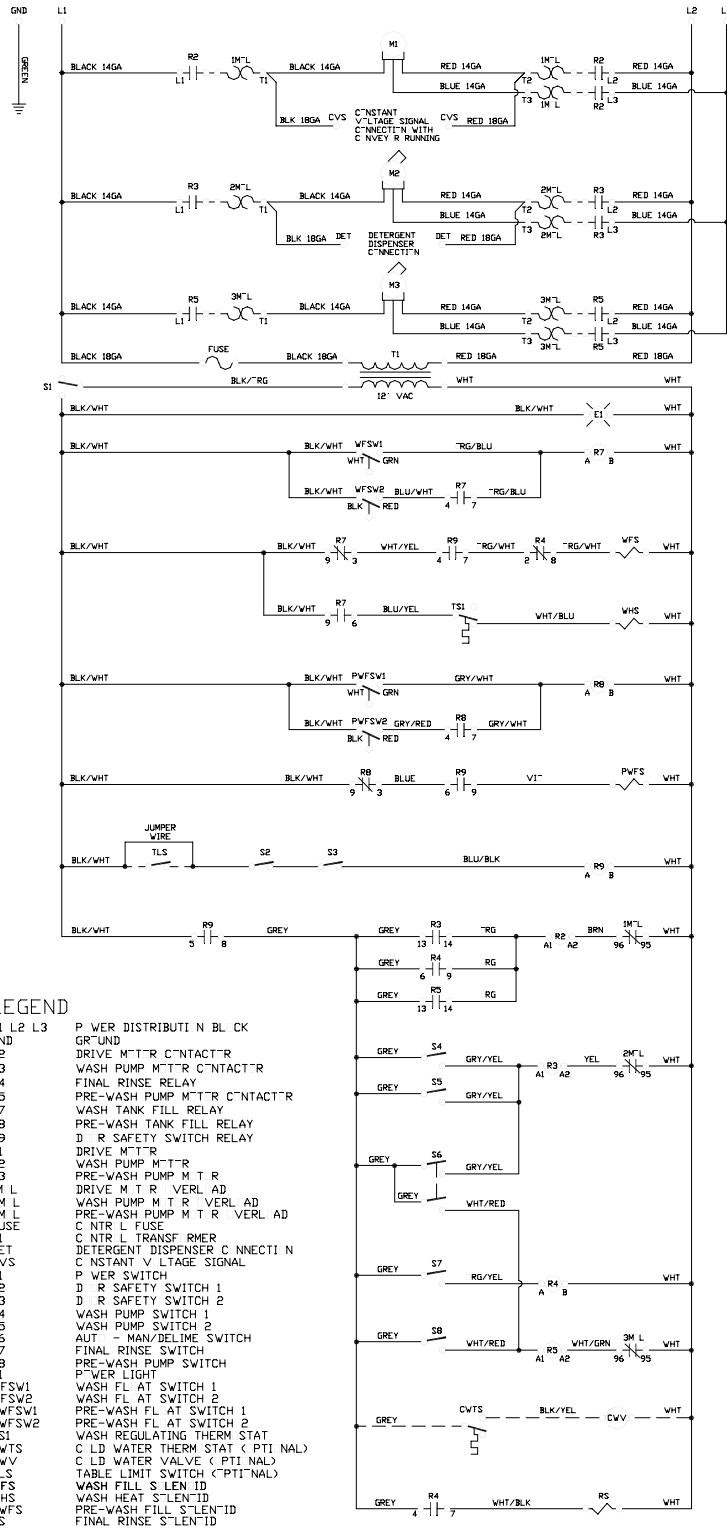

09905-002-46-98

SECTION 7: ELECTRICAL SCHEMATICS

AJ-76CS & AJ-90CS (460-575-600 VOLT, 60 HZ, THREE PHASE)

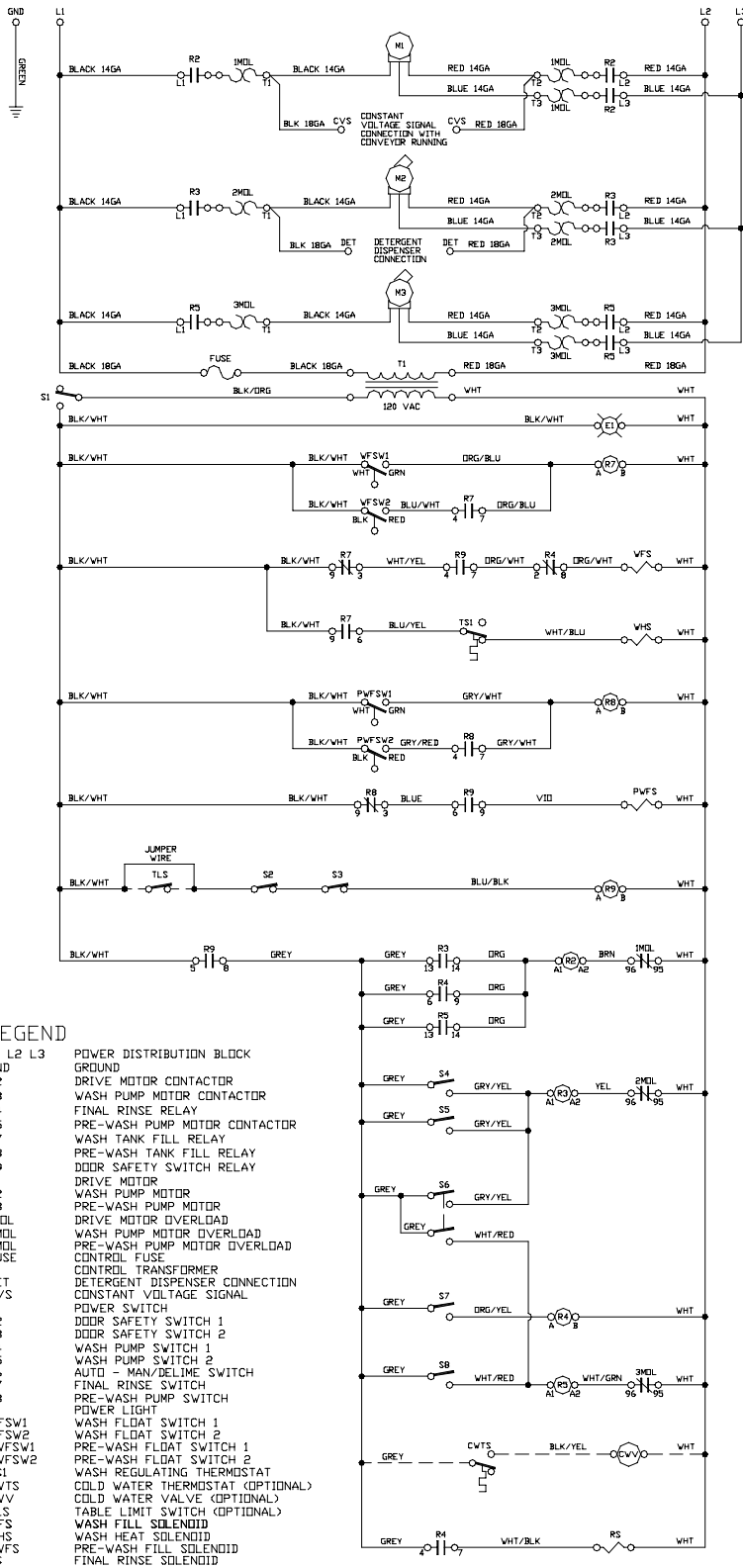

- LEGEND**
- L1 L2 L3 POWER DISTRIBUTION BLOCK
 - GND GROUND
 - R2 DRIVE MOTOR CONTACTOR
 - R3 WASH PUMP MOTOR CONTACTOR
 - R4 FINAL RINSE RELAY
 - R5 PRE-WASH PUMP MOTOR CONTACTOR
 - R7 WASH TANK FILL RELAY
 - R8 PRE-WASH TANK FILL RELAY
 - R9 DDDR SAFETY SWITCH RELAY
 - M1 DRIVE MOTOR
 - M2 WASH PUMP MOTOR
 - M3 PRE-WASH PUMP MOTOR
 - 1MOL DRIVE MOTOR OVERLOAD
 - 2MOL WASH PUMP MOTOR OVERLOAD
 - 3MOL PRE-WASH PUMP MOTOR OVERLOAD
 - FUSE FUSE
 - T1 CONTROL TRANSFORMER
 - DET DETERGENT DISPENSER CONNECTION
 - CVS CONSTANT VOLTAGE SIGNAL
 - S1 POWER SWITCH
 - S2 DDDR SAFETY SWITCH 1
 - S3 DDDR SAFETY SWITCH 2
 - S4 WASH PUMP SWITCH 1
 - S5 WASH PUMP SWITCH 2
 - S6 AUTO - MAN/DELTIME SWITCH
 - S7 FINAL RINSE SWITCH
 - S8 PRE-WASH PUMP SWITCH
 - E1 POWER LIGHT
 - WFSW1 WASH FLDAT SWITCH 1
 - WFSW2 WASH FLDAT SWITCH 2
 - PWFSW1 PRE-WASH FLDAT SWITCH 1
 - PWFSW2 PRE-WASH FLDAT SWITCH 2
 - TS1 WASH REGULATING THERMOSTAT
 - CWTS COLD WATER THERMOSTAT (OPTIONAL)
 - CWV COLD WATER VALVE (OPTIONAL)
 - WFS WASH FILL SOLENOID
 - WHS WASH HEAT SOLENOID
 - PWFS PRE-WASH FILL SOLENOID
 - RS FINAL RINSE SOLENOID

SECTION 7: ELECTRICAL SCHEMATICS

AJ-54CGP (208-230 VOLT, 60 HZ, SINGLE PHASE)

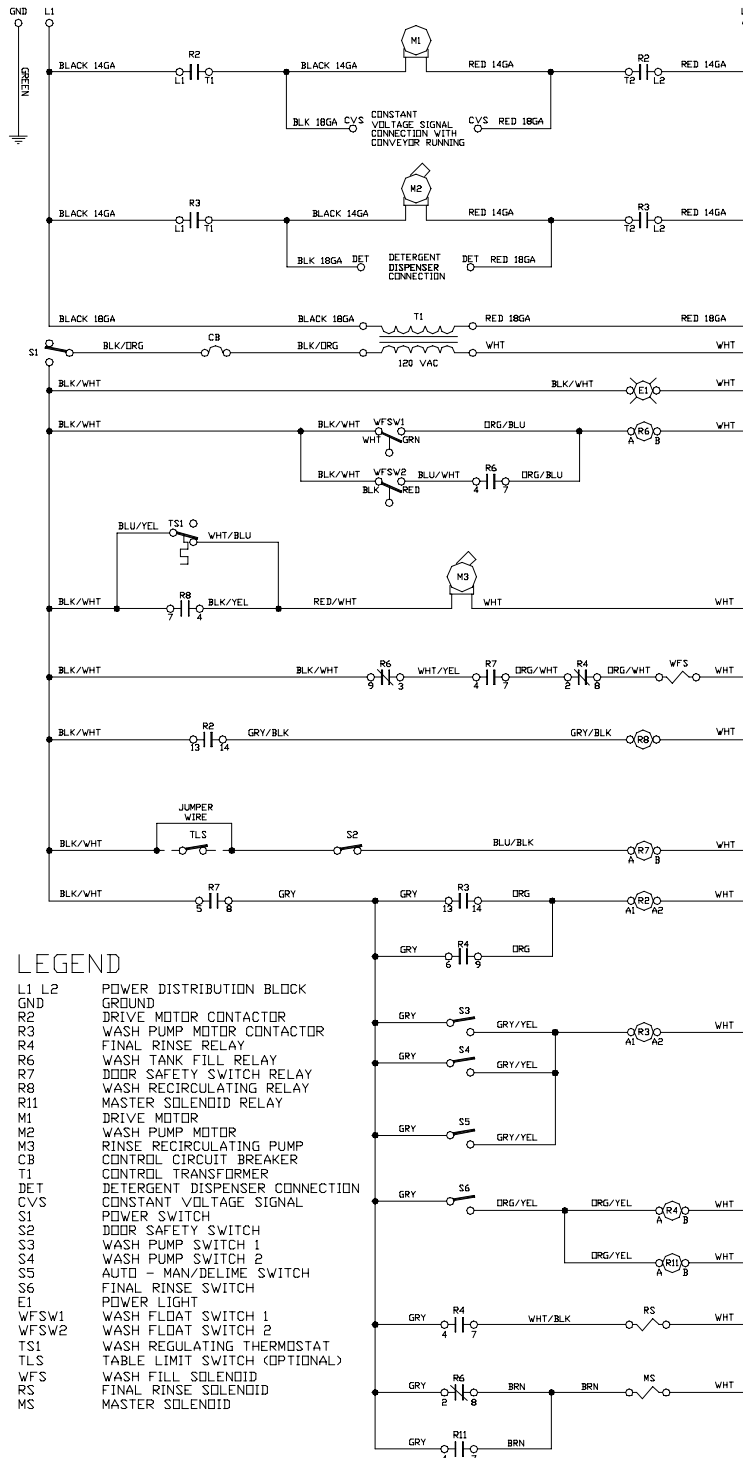

LEGEND

- L1 L2 POWER DISTRIBUTION BLOCK
- GND GROUND
- R2 DRIVE MOTOR CONTACTOR
- R3 WASH PUMP MOTOR CONTACTOR
- R4 FINAL RINSE RELAY
- R6 WASH TANK FILL RELAY
- R7 DOOR SAFETY SWITCH RELAY
- R8 WASH RECIRCULATING RELAY
- R11 MASTER SOLENOID RELAY
- M1 DRIVE MOTOR
- M2 WASH PUMP MOTOR
- M3 RINSE RECIRCULATING PUMP
- CB CONTROL CIRCUIT BREAKER
- T1 CONTROL TRANSFORMER
- DET DETERGENT DISPENSER CONNECTION
- CVS CONSTANT VOLTAGE SIGNAL
- S1 POWER SWITCH
- S2 DOOR SAFETY SWITCH
- S3 WASH PUMP SWITCH 1
- S4 WASH PUMP SWITCH 2
- S5 AUTO - MAN/DELIME SWITCH
- S6 FINAL RINSE SWITCH
- E1 POWER LIGHT
- WFSW1 WASH FLEAT SWITCH 1
- WFSW2 WASH FLEAT SWITCH 2
- TS1 WASH REGULATING THERMOSTAT
- TLS TABLE LIMIT SWITCH (OPTIONAL)
- WFS WASH FILL SOLENOID
- RS FINAL RINSE SOLENOID
- MS MASTER SOLENOID

9905-002-52-42

SECTION 7: ELECTRICAL SCHEMATICS

AJ-54CGP (208-230 VOLT, 60 HZ, THREE PHASE)

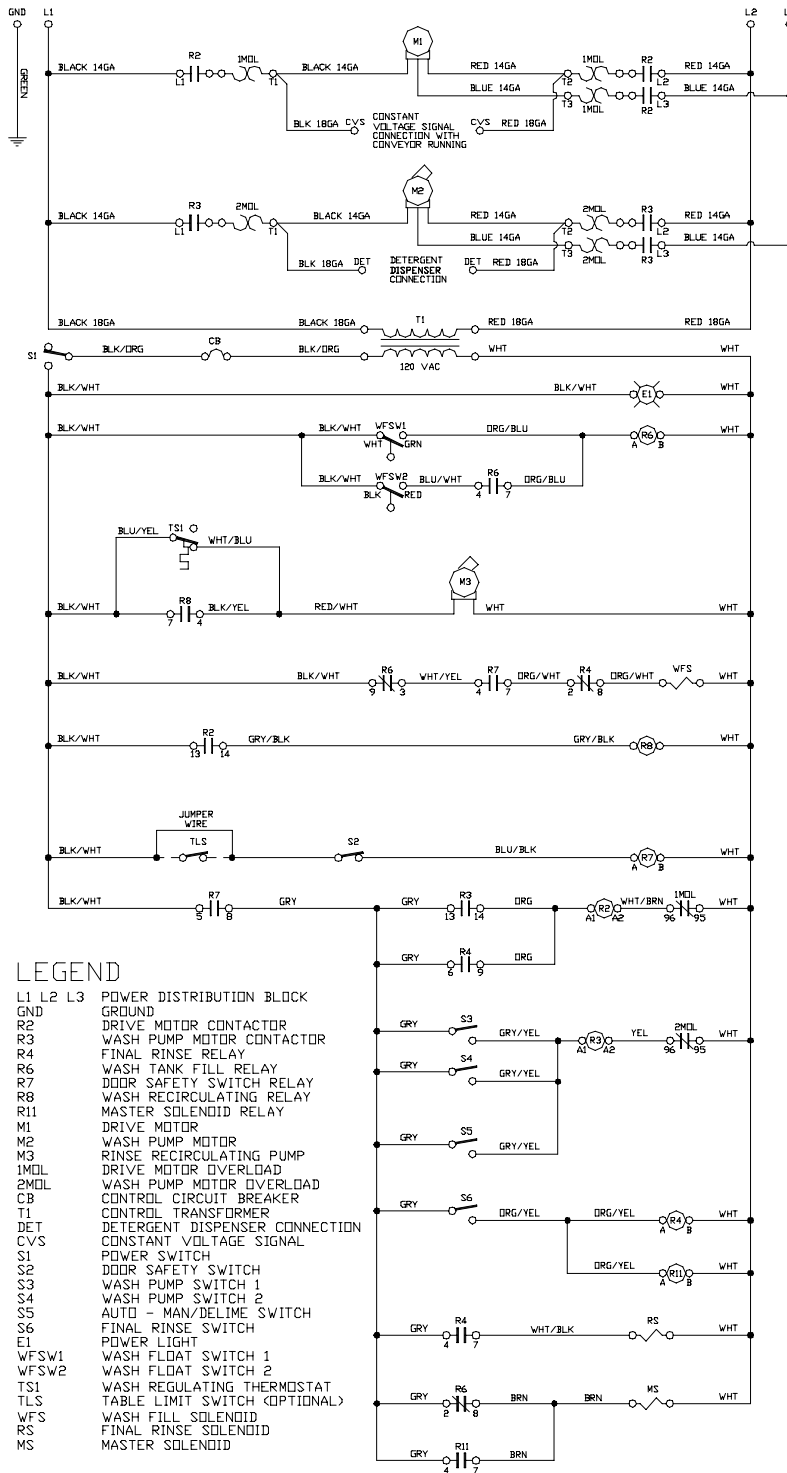

9905-002-33-11a

SECTION 7: ELECTRICAL SCHEMATICS

AJ-54CGP (460 VOLT, 60 HZ, 3 PHASE)

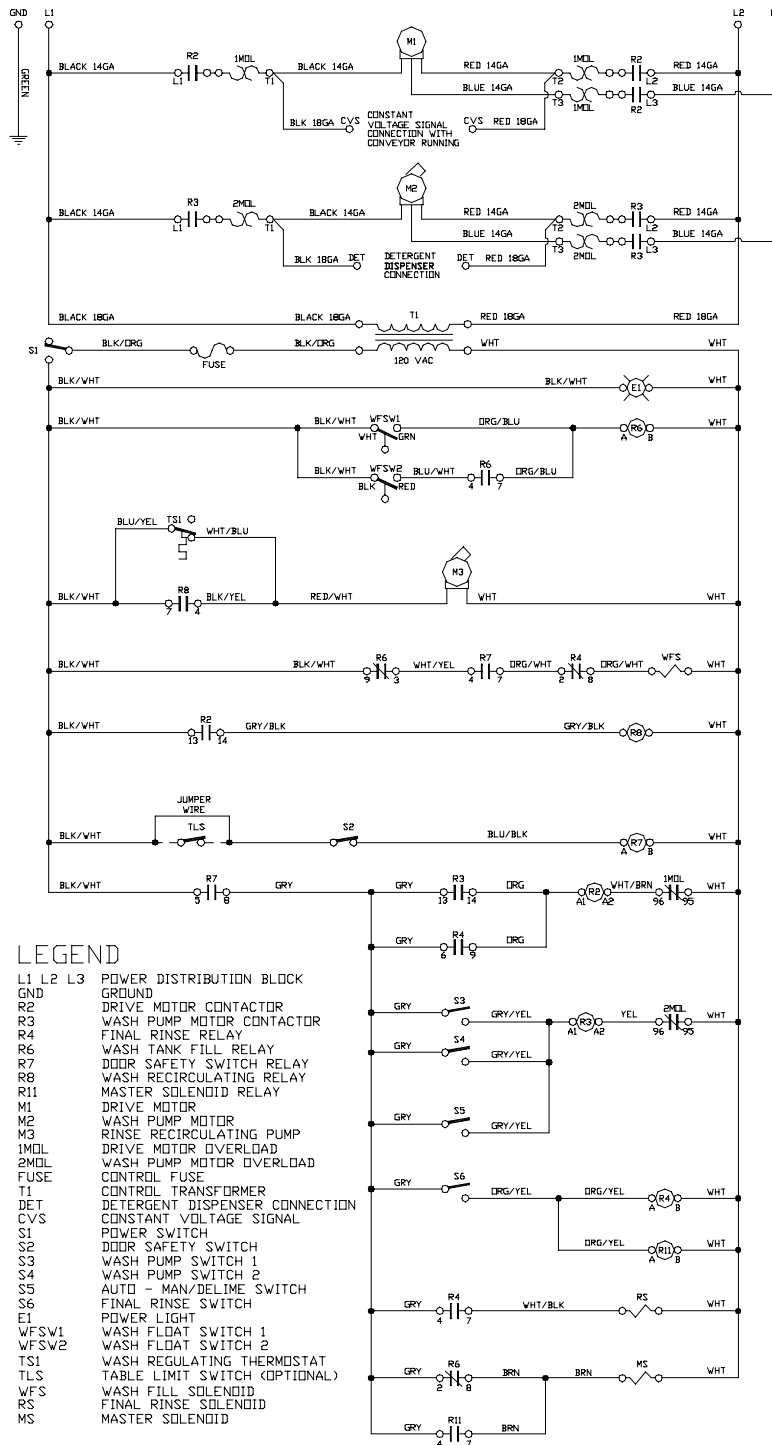

9905-002-53-24

SECTION 7: ELECTRICAL SCHEMATICS

AJ-76CGP (208-230 VOLTS, 60 HZ, SINGLE PHASE)

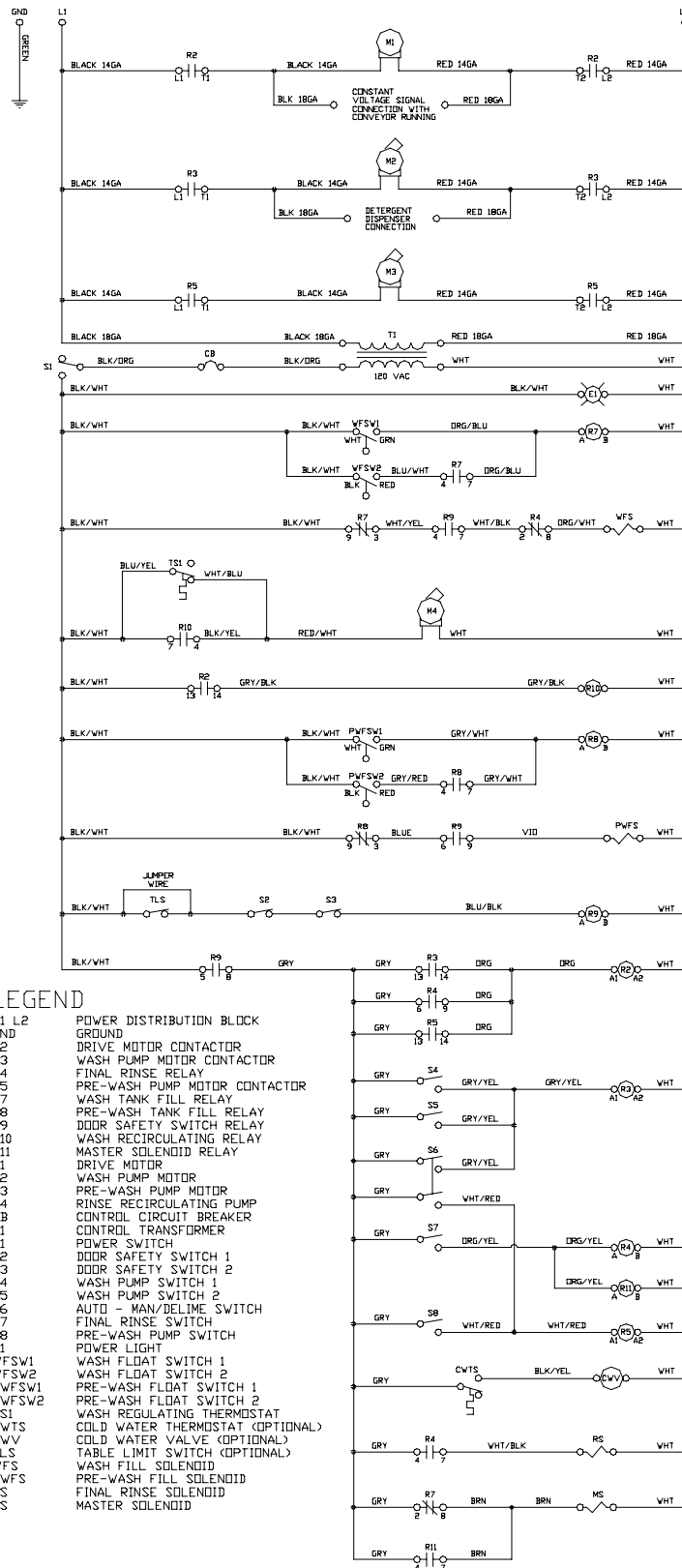

9905-002-53-26

SECTION 7: ELECTRICAL SCHEMATICS

AJ-76CGP (208-230 VOLTS, 60 HZ, THREE PHASE)

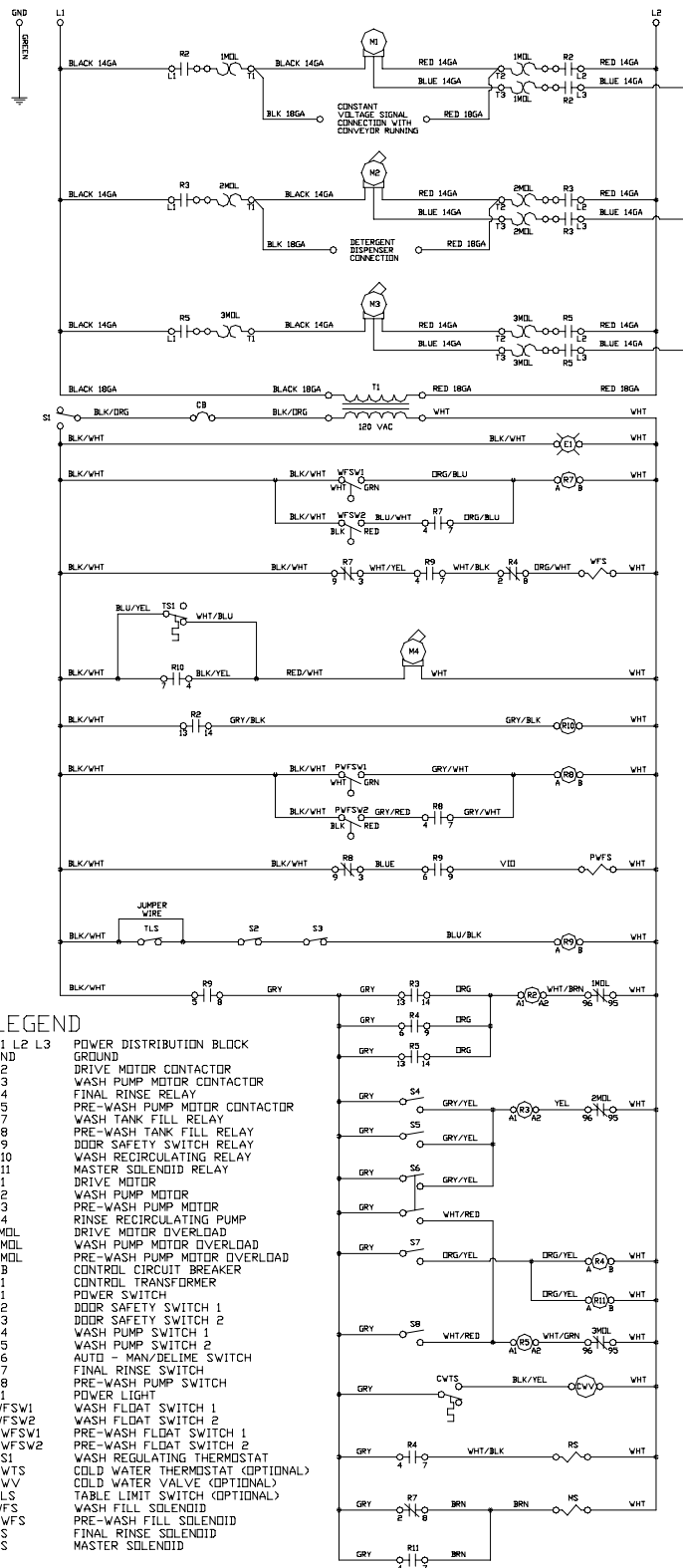

9905-002-33-61c

SECTION 7: ELECTRICAL SCHEMATICS

AJ-76CGP (460 VOLTS, 60 HZ, THREE PHASE)

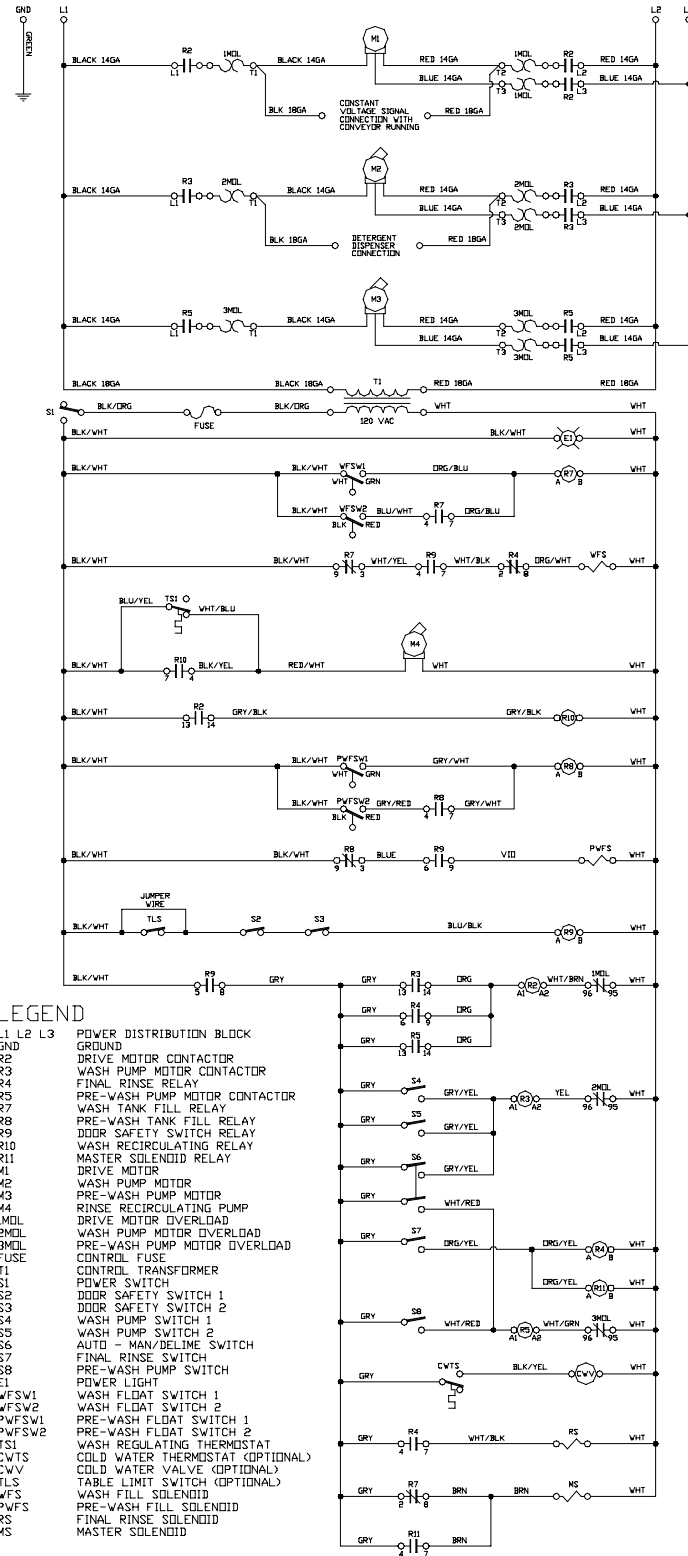

9905-002-53-25

SECTION 7: ELECTRICAL SCHEMATICS
CONVEYOR EXHAUST FAN HOOKUP

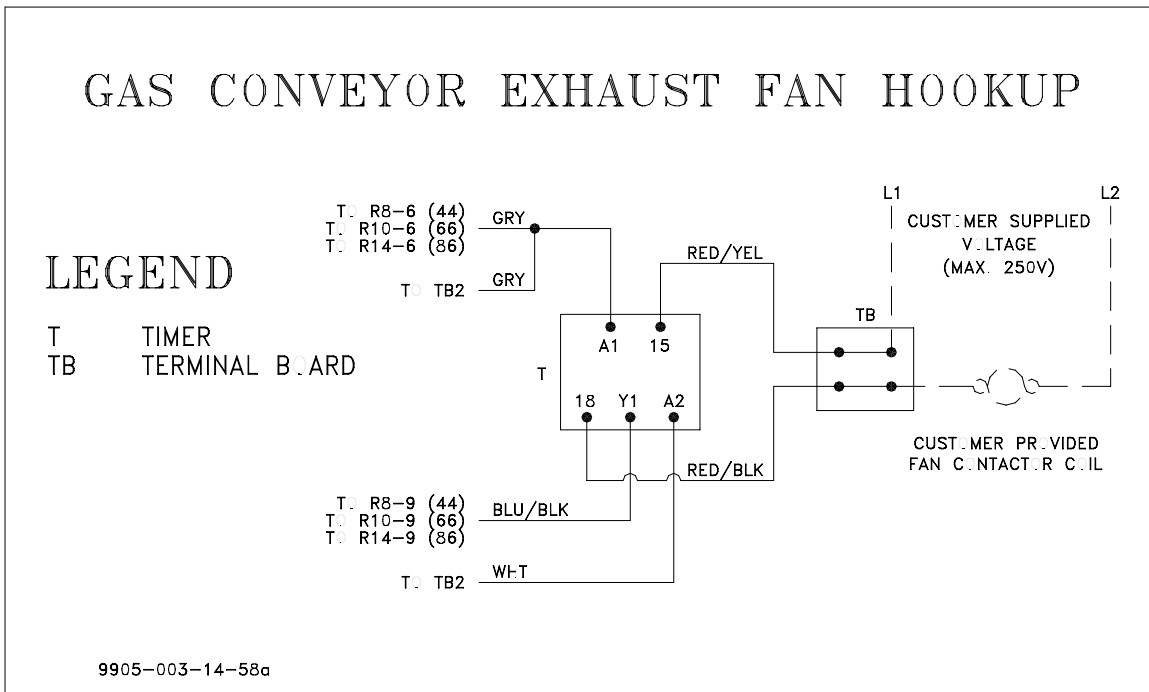
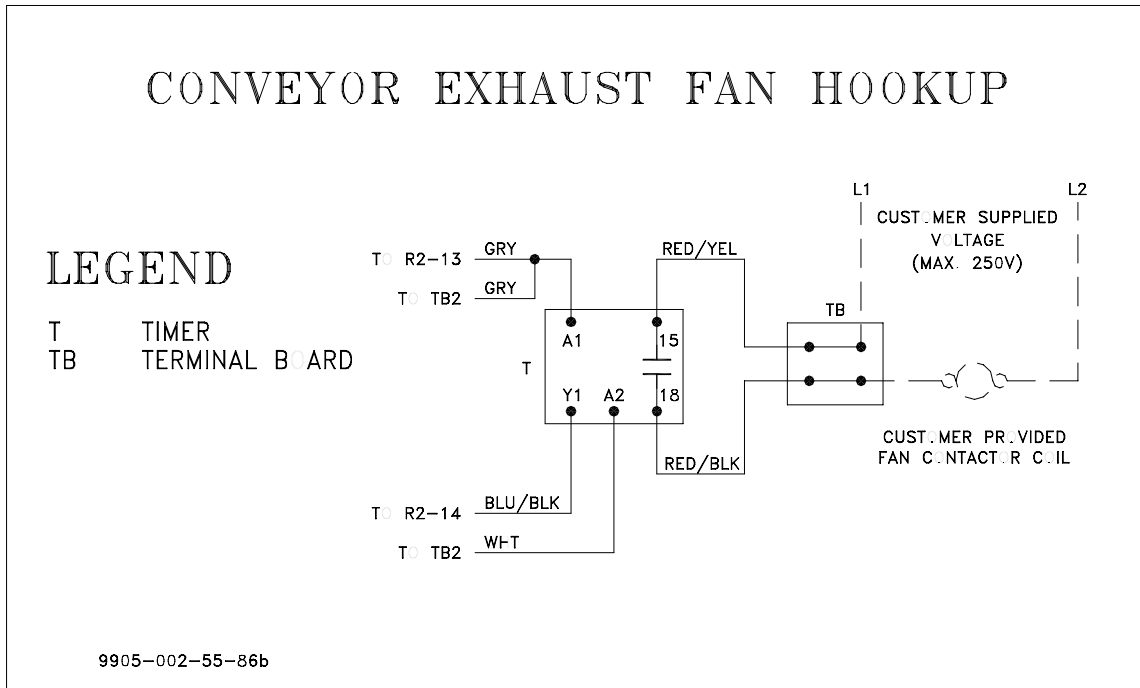

SECTION 7: ELECTRICAL SCHEMATICS

D226 STEAM BOOSTER/DRAIN QUENCH SYSTEM/SIDE LOADER

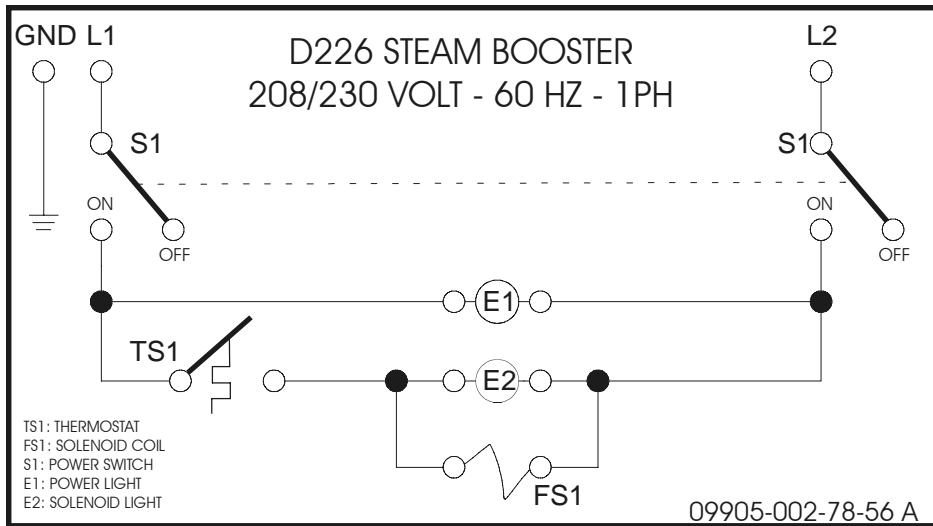

DRAIN QUENCH SYSTEM

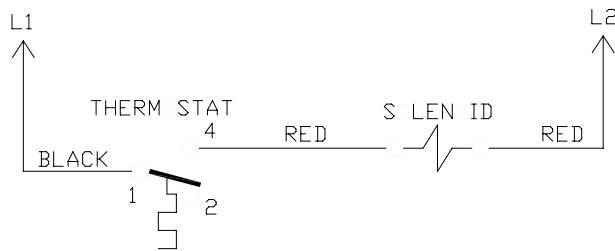

CONNECT BLACK WIRE TO THERM CONTACTOR - L1 WITH PIGGYBACK TERMINAL PROVIDED
CONNECT WHITE WIRE TO THERM CONTACTOR - L2 WITH PIGGYBACK TERMINAL PROVIDED

CONVEYOR SIDE LOADER

54 CONVEYORS

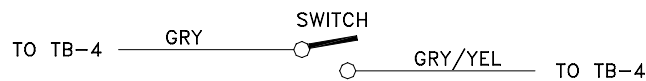

76 & 90 CONVEYORS

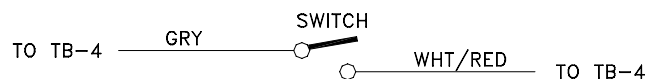

9905-002-56-84a

**SECTION 8:
JACKSON MAINTENANCE
& REPAIR CENTERS**

SECTION 8: JACKSON MAINTENANCE & REPAIR CENTERS

ALABAMA TO FLORIDA

ALABAMA

JONES-McLEOD APPLIANCE SVC

1616 7TH AVE. NORTH
BIRMINGHAM, AL 35203
(205) 251-0159
800-821-1150
FAX: (205) 322-1440
service@jones-mcleod.com

JONES-McLEOD APPLIANCE SVC

854 LAKESIDE DRIVE
MOBILE, AL 36693
(251) 666-7278
800-237-9859
FAX: (251) 661-0223

ALASKA

RESTAURANT APPLIANCE SERVICE

7219 ROOSEVELT WAY NE
SEATTLE, WA 98115
(206) 524-8200
800-433-9390
FAX: (206) 525-2890
info@restappl.com

ARIZONA

AUTHORIZED COMMERCIAL FOOD EQMT. SVC

4832 SOUTH 35TH STREET
PHOENIX, AZ 85040
(602) 234-2443
800-824-8875
FAX: (602) 232-5862
acsboss@aol.com

GCS SERVICE INC.

PHOENIX, AZ
(602) 474-4510
800-510-3497
FAX: (602) 470-4511

ARKANSAS

BROMLEY PARTS & SVC

10TH AND RINGO
P.O. BOX 1688
LITTLE ROCK, AR 72202
(501) 374-0281
800-482-9269
FAX: (501) 374-8352
service@bromleyparts.com
parts@bromleyparts.com

GCS SERVICE, INC.

3717 CHERRY ROAD
MEMPHIS, TN 38118
(901) 366-4587
800-262-9155
FAX: (901) 366-4588

CALIFORNIA

BARKERS FOOD MACHINERY SERVICES

5367 SECOND STREET
IRWINDALE, CA 91706
(626) 960-9390
800-258-6999
FAX: (626) 337-4541
service@barkers.com

GCS SERVICE INC.

LOS ANGELES, CA
(213) 683-2090
800-327-1433
FAX: (213) 683-2099

GCS SERVICE INC.

SANTA ANA, CA
(714) 542-1798
800-540-0719
FAX: (714) 542-4787

GCS SERVICE INC.

S. SAN FRANCISCO, CA
(650) 635-0720
800-969-4427
FAX: (650) 871-4019

COMMERCIAL APPLIANCE SERVICE, INC.

6507 PACIFIC AVENUE, SUITE 102
STOCKTON, CA 95207
(916) 567-0203
(800) 464-2222
(916) 567-0266 FAX

GCS SERVICE INC.

SAN DIEGO, CA
(858) 549-8411
800-422-7278
FAX: (858) 549-2323

INDUSTRIAL ELECTRIC SVC.

5662 ENGINEER DRIVE
HUNTINGTON BEACH, CA 92649
(714) 379-7100
(800-457-3783
FAX: (714) 379-7109

P & D APPLIANCE SVC

100 SOUTH LINDEN AVE.
S. SAN FRANCISCO, CA 94080
(650) 635-1900
800-424-1414
FAX: (650) 635-1919
pndappl@aol.com

P & D APPLIANCE

4220-C ROSEVILLE ROAD
NORTH HIGHLANDS, CA 95660
(916) 974-2772
800-824-7219
FAX: (916) 974-2774

COMMERCIAL APPLIANCE SERVICE, INC.

281 LATHROP WAY, #100
SACRAMENTO, CA 95815
(916) 567-0203
(800) 464-2222
(916) 567-0324 FAX

COLORADO

GCS SERVICE INC.

SHERIDAN, CO
(303) 371-9054
800-972-5314
FAX: (303) 371-4754

HAWKINS COMMERCIAL APPLIANCE SERVICE

3000 S. WYANDOT ST.
ENGLEWOOD, CO 80110
(303) 781-5548
(800) 624-2117
FAX: (303) 761-5561
johns@hawkinscommercial.com

METRO APPLIANCE SERVICE

1640 S BROADWAY
DENVER, CO 80210
(303) 778-1126
800-525-3532
FAX: (303) 778-0268
metroappls@aol.com

CONNECTICUT

GCS SERVICE INC.

HARTFORD, CT
(860) 549-5575
800-423-1562
FAX: (860) 527-6355

SUPERIOR KITCHEN SERVICE INC.

22 THOMPSON ROAD
WINDSOR, CT 06088
(888) 590-1899
(888) 590-1996 FAX

DELAWARE

FOOD SERVICE EQMT.

2101 PARKWAY SOUTH
BROOMALL, PA 19008
(610) 356-6900
FAX: (610) 356-2038
dancerule@aol.com

GCS SERVICE INC.

PHILADELPHIA, PA
(215)925-6217
800-441-9115
FAX: (215) 925-6208

ELMER SCHULTZ SERVICE

36 BELMONT AVE.
WILLMINGTON, DE 19804
(302) 655-8900
800-225-0599
FAX: (302) 656-3673
elmer2@erols.com

EMR SERVICE DIVISION

106 WILLIAMSPORT CIRCLE
SALISBURY, MD 21804
(410) 543-8197
FAX: (410) 548-4038

FLORIDA

COMMERCIAL APPLIANCE SERVICE

8416 LAUREL FAIR CIRCLE
BLDG 6, SUITE 114
TAMPA, FL 33610
(813) 663-0313
800-282-4718
FAX: (813) 663-0212
commercialappliance@world-net.att.net

GCS SERVICE INC

MIAMI, FL
(305) 621-6666
800-766-8966
FAX: (305) 621-6656

GCS SERVICE INC

ORLANDO, FL
(407) 841-2551
800-338-7322
FAX: (407) 423-8425

NASS PARTS AND SERVICE, INC.

1144 BELVILLE ROAD, UNIT 359
DAYTONA BEACH, FL 32114
(386) 226-2642
(800) 432-2795
(386) 736-7695 FAX

GCS SERVICE INC

TAMPA, FL
(813) 626-6044
800-282-3008
FAX: (813) 621-1174

SECTION 8: JACKSON MAINTENANCE & REPAIR CENTERS

FLORIDA TO MARYLAND**JONES-McLEOD APPLIANCE
SVC**

854 LAKESIDE DRIVE
MOBILE, AL 36693
(251) 666-7278
800-237-9859
FAX: (251) 661-0223
service@jones-mcleod.com

**NASS PARTS AND SERVICE,
INC.**

1108 SOUTH WOODS AVENUE
ORLANDO, FL 32805
(407) 425-2681
(800) 432-2795
(407) 425-3463 FAX

**NASS PARTS AND SERVICE,
INC.**

1376 HEIDE AVENUE
PALM BAY, FL 32907
(321) 952-2012
(800) 432-2795
(321) 953-0266 FAX

GEORGIA**GCS SERVICE INC**

ATLANTA, GA
(770) 452-7322
800-334-3599
FAX: (770) 452-7473

HERITAGE FOODSERVICE

GROUP OF ATLANTA
2100 NORCROSS PKWY.
SUITE 130
NORCROSS, GA 30071
(770) 368-1465
866-388-9837
FAX: (866) 388-9838

**WHALEY FOODSERVICE
REPAIRS**

109-A OWENS INDUSTRIAL
DRIVE
SAVANNAH, GA 31405
(912) 447-0827
888-765-0036
FAX: (912) 447-0826

PIERCE PARTS & SERVICE

2422 ALLEN ROAD
MACON, GA 31216
(478) 781-6003
800-368-2512
FAX: (478) 781-7186

HAWAII**FOOD EQMT. PARTS &
SERVICE CO.**

300 PUUHALE RD.
HONOLULU, HI 96819
(808) 847-4871
FAX: (808) 842-1560
fepsco@hula.net

IDAHO**RESTAURANT APPLIANCE
SVC.**

7219 ROOSEVELT WAY NE
SEATTLE, WA 98115
(206) 524-8200
800-433-9390
FAX: (206) 525-2890
info@restappl.com

RON'S SERVICE

703 E 44TH STREET STE 10
GARDEN CITY, ID 83714
(208) 375-4073
FAX: (208) 375-4402

ILLINOIS**CONES REPAIR SVC.**

2408 40TH AVE.
MOLINE, IL 61265
(309) 797-5323
800-716-7070
FAX: (309) 797-3631
jackb@cones.com

EICHENAUER SERVICES INC.

130 S OAKLAND ST.
DECATUR, IL 62522
(217) 429-4229
800-252-5892
FAX: (217) 429-0226
esi@esiquality.com

GCS SERVICE INC.

ELMHURST, IL
(630) 941-7800
800-942-9689
FAX: (630) 941-6048

GCS SERVICE INC.

ST. LOUIS, MO
(314) 683-7444
800-284-4427
FAX: (314) 638-0135

GENERAL PARTS, INC.

248 JAMES STREET
BENSONVILLE, IL 60106
(630) 595-3300
(800) 880-3604
FAX: (630) 595-0006

INDIANA**GCS SERVICE INC.**

INDIANAPOLIS, IN
(317) 545-9655
800-727-8710
FAX: (317) 549-6286

B622 LA PAS TRAIL

INDIANAPOLIS, IN 46268
(317) 290-8060
(800) 410-9794
(317) 290-8085 FAX

IOWA**GOODWIN TUCKER GROUP****2900 DELAWARE AVENUE**

DES MOINES, IA 50317
(515) 262-9308
800-372-6066
FAX: (515) 262-2936
parts@goodwintucker.com

CONES REPAIR SVC.

1056 27TH AVENUE SW
CEDAR RAPIDS, IA 52404
(319) 365-3325
800-747-3326
FAX: (319) 365-0885

KANSAS**GCS SERVICE INC.**

KANSAS CITY, MO
(816) 920-5999
800-229-6477
FAX: (816) 920-7387

GENERAL PARTS, INC.

1101 E. 13TH STREET
KANSAS CITY, MO 64106
(816) 421-5400
(800) 279-9967
(816) 421-1270 FAX

KENTUCKY**CERTIFIED SERVICE CENTER**

127 DISHMAN LANE
BOWLING GREEN, KY 42101
(270) 783-0012
(877) 907-0012
FAX: (270) 783-0058

CERTIFIED SERVICE CENTER**RAMCO BUSINESS PARK**

4283 PRODUCE ROAD
LOUISVILLE, KY 40218
(502) 964-7007
800-637-6350
FAX: (502) 964-7202
cwalker@certifiedsc.com
droenigk@certifiedsc.com

CERTIFIED SERVICE CENTER

1051 GOODWIN DRIVE
LEXINGTON, KY 40505
(606) 254-8854
800-432-9269
FAX: (606) 231-7781
jatkings@certifiedsc.com

GCS SERVICE INC.

LOUISVILLE, KY
(502) 367-1788
800-752-6160
FAX: (502) 367-0400

GCS SERVICE INC.

LEXINGTON, KY
(606) 255-0746
800-432-9260
FAX: (606) 255-0748

LOUISIANA**HERITAGE SERVICE GROUP**

1532 RIVER OAKS WEST
NEW ORLEANS, LA 70123
(504) 734-8864
(800) 499-2351
(504) 733-2559 FAX

MAINE**GCS SERVICE INC.**

CHELSEA, MA
(617) 889-9393
800-225-1155
FAX: (617) 889-1222

**MASSACHUSETTS RESTAU-
RANT SUPPLY**

34 SOUTH STREET
SOMERVILLE, MA 02143
(617) 868-1930
800-338-6737
FAX: (617) 686-5331

**PINE TREE FOOD EQUIP-
MENT**

175 LEWISTON ROAD
GRAY, ME 04039
(207) 657-6400
(800) 540-5427
(207) 657-5464 FAX

MARYLAND**EMR SERVICE DIVISION**

700 EAST 25TH STREET
BALTIMORE, MD 21218
(410) 467-8080
800-879-4994
FAX: (410) 467-4191
baltparts@emrco.com

SECTION 8: JACKSON MAINTENANCE & REPAIR CENTERS

MARYLAND TO NEW YORK

EMR SERVICE DIVISION
106 WILLIAMSPORT CIRCLE
SALISBURY, MD 21804
(410) 543-8197
888-687-8080
FAX: (410) 548-4038
baltparts@emrco.com

EMR SERVICE DIVISION

5316 Sunnyside Ave.
Beltsville, MD 20715
(301) 931-7000
800-348-2365
FAX: (301) 931-3060
baltparts@emrco.com

GCS SERVICE INC.

SILVER SPRING, MD
(301) 585-7550 (DC)
(410) 792-0338 (BALT)
(800) 638-7278
FAX: (301) 495-4410

MASSACHUSETTS

ACE SERVICE CO.

95 HAMPTON AVE.
NEEDHAM, MA 02494
(781) 449-4220
800-225-4510 MA & NH
FAX: (781) 444-4789
taceservice@aol.com

MASSACHUSETTS RESTAU- RANT SUPPLY

34 SOUTH STREET
SOMERVILLE, MA 02143
(617) 868-1930
800-338-6737
FAX: (617) 868-5331

GCS SERVICE INC.

CHELSEA, MA
(617) 889-9393
800-225-1155
FAX: (617) 889-1222

GCS SERVICE INC.

HARTFORD, CT
(860) 549-5575
800-723-1562
FAX: (860) 527-6355

SUPERIOR KITCHEN SER- VICE INC.

399 FERRY STREET
EVERETT, MA 02149
(617) 389-1899
(888) 590-1899
(617) 389-1996 FAX

MICHIGAN

GCS SERVICE INC.

LIVONIA, MI
(248) 426-9500
800-772-2936
FAX: (248) 426-7555

JACKSON SERVICE COMPA- NY

3980 BENSTEIN RD.
COMMERCE TWSHP, MI 48382
(248) 363-4159
800-332-4053
FAX: (248) 363-5448

GCS SERVICE INC.

GRAND RAPIDS, MI
(616) 241-0200
800-823-4866
FAX: (616) 241-0541

MINNESOTA

GCS SERVICE INC.

MINNEAPOLIS, MN
(612) 546-4221
800-345-4221
FAX: (612) 546-4286

GENERAL PARTS, INC.

11311 HAMPSHIRE AVENUE
SOUTH
BLOOMINGTON, MN 55438-
2456
(952) 944-5800
(800) 279-9980
(800) 279-9980 FAX

MISSISSIPPI

GCS SERVICE INC.

JACKSON, MS
(601) 956-7800
800-274-5954
FAX: (601) 956-1200

GCS SERVICE INC.

MEMPHIS, TN
(901) 366-4587
800-262-9155
FAX: (901) 366-4588

MISSOURI

GCS SERVICE INC.

KANSAS CITY, MO
(816) 920-5999
800-229-6477
FAX: (816) 920-7387

GCS SERVICE INC.

ST. LOUIS, MO
(314) 638-7444
800-284-4427
FAX: (314) 638-0135

KAEMMERLIN PARTS & SVC.

2728 LOCUST STREET
ST. LOUIS, MO 63103
(314) 535-2222
FAX: (314) 535-6205
petek@kps.stl.com

GENERAL PARTS, INC.

1101 EAST 13TH STREET
KANSAS CITY, MO 64106
(816) 421-5400
(800) 279-9967
(816) 421-1270 FAX

MONTANA

RESTAURANT APPLIANCE SVC.

7219 ROOSEVELT WAY NE
SEATTLE, WA 98115
(206) 524-8200
800-433-9390
FAX: (206) 525-2890
info@restappl.com

NEBRASKA

GOODWIN - TUCKER GROUP

7535 D STREET
OMAHA, NE 68124
(402) 397-2880
800-228-0342
FAX: (402) 397-2881
askme@goodwintucker.com

NEVADA

HI TECH COMMERCIAL SER- VICE

1840 STELLA LAKE STREET
NORTH LAS VEGAS, NV 89106
(702) 649-4616
(877) 924-4832
FAX: (702) 649-4607
larry@hitechnv.com

5454 LOUIE LANE
RENO, NV 89511
(775) 852-9696
FAX: (775) 852-5104

GCS SERVICE INC.

LAS VEGAS, NV
(702) 450-3495
800-500-9060
FAX: (702) 450-3491

NEW HAMPSHIRE

GCS SERVICE INC.

CHELSEA, MA
(617)889-9393
800-225-1155
FAX: (617) 889-1222

ACE SERVICE CO.

95 HAMPTON AVE.
NEEDHAM, MA 02494
(781) 449-4220
800-225-4510 MA & NH
FAX: (781) 444-4789
taceservice@aol.com

MASSACHUSETTS RESTAU- RANT SUPPLY

34 SOUTH STREET
SOMERVILLE, MA 02143
(617) 868-1930
800-338-6737
FAX: (617) 868-5331

NEW JERSEY

JAY HILL REPAIRS

90 CLINTON RD.
FAIRFIELD, NJ 07004
(973) 575-9145
800-836-0643
FAX: (973) 575-5890
jhrepair@aol.com

GCS SERVICE INC.

EAST RUTHERFORD, NJ
(973) 614-0003
800-399-8294
FAX: (973) 614-0230

GCS SERVICE INC.

PHILADELPHIA, PA
(215) 925-6217
800-441-9115
FAX: (215) 925-6208

ELMER SCHULTZ SERVICES

201 W. WASHINGTON AVE.
PLEASANTVILLE, NJ 08232
(609) 641-0317
800-378-1641
FAX: (609) 641-8703
elmer2@erols.com

NEW YORK

APPLIANCE INSTALLATION AND SERVICE CORP.

1336 MAIN STREET
BUFFALO, NY 14209
(716) 884-7425
800-722-1252
FAX: (716) 884-0410
ais@worldnet.att.net

SECTION 8: JACKSON MAINTENANCE & REPAIR CENTERS

NEW YORK TO PENNSYLVANIA

B.E.S.T. INC.

3003 GENESEE STREET
BUFFALO, NY 14225
(716) 893-6464
800-338-5011
FAX: (716) 893-6466
bestserv@aol.com

DUFFY'S EQUIPMENT SVC.

3138 ONEIDA STREET
SAUQUOIT, NY 13456
(315) 737-9401
800-443-8339
FAX: (315) 737-7132
duffyequip@aol.com

NORTHERN PARTS & SVC.

21 NORTHERN AVENUE
PLATTSBURGH, NY 12903
(518) 563-3200
800-634-5005
FAX: (800) 782-5424
info@northernparts.com

GCS SERVICE INC.

BROOKLYN, NY
(718) 486-5220
800-969-4271
FAX: (718) 486-6772

ALL SERVICE KITCHEN

EQUIPMENT REPAIR
10 CHARLES ST.
NEW HYDE PARK, NY 11040
(516) 378-1176
FAX: (516) 378-1735

ALL ISLAND REPAIRS

40-9 BURT DRIVE
DEER PARK, NY 11729
(631) 242-5588
FAX: (631) 242-6102

NORTH CAROLINA

AUTHORIZED APPLIANCE SERVICECENTER

1020 TUCKASEEGEE RD.
CHARLOTTE, NC 28208
(704) 377-4501
(800) 532-6127
FAX:(704) 377-4504

AUTHORIZED APPLIANCE SERVICECENTER

800 N. PERSON ST.
RALEIGH, NC 27604
(919) 834-3476
FAX:(919) 834-3477

AUTHORIZED APPLIANCE SERVICECENTER

904 S. MARSHALL ST.
WINSTON-SALEM, NC 27403
(336) 725-5396
FAX:(336) 721-1289

AUTHORIZED APPLIANCE SERVICECENTER

104 HINTON AVE.
WILMINGTON, NC 28403
(910) 313-1250
FAX:(910) 313-6130

WHALEY FOODSERVICE

8334-K ARROWRIDGE BLVD
CHARLOTTE, NC 28273
(704) 529-6242
FAX: (704) 529-1558
info@whaleyfoodservice.com

WHALEY FOODSERVICE REPAIRS

203-D CREEK RIDGE RD.
GREENSBORO, NC 27406
(336) 333-2333
FAX: (336) 333-2533
info@whaleyfoodservice.com

WHALEY FOODSERVICE REPAIRS

335-105 SHERWEE DRIVE
RALEIGH, NC 27603
(919) 779-2266
FAX: (919) 779-2224
info@whaleyfoodservice.com

WHALEY FOODSERVICE REPAIRS

6418-101 AMSTERDAM WAY
WILMINGTON, NC 28405
(910) 791-0000
FAX: (910) 791-6662
info@whaleyfoodservice.com

NORTH DAKOTA

GCS SERVICE INC.

MINNEAPOLIS, MN
(612) 546-4221
800-345-4221
FAX: (612) 546-4286

GENERAL PARTS, INC.

10 SOUTH 18TH STREET
FARGO, ND 58103
(701) 235-4161
(800) 279-9987
(701) 235-0539 FAX

OHIO

CERTIFIED SERVICE CENTER

890 REDNA TERRACE
CINCINNATI, OH 45215
(513) 772-6600
800-543-2060
FAX: (513) 612-6600
sbarasch@certifiedsc.com

CERTIFIED SERVICE CENTER

171J-K NORTH HAMILTON RD.
COLUMBUS, OH 43213
(614) 751-3769
(866) 862-1252
FAX: (614) 751-5792
jadkins@certifiedsc.com

CERTIFIED SERVICE CENTER

6025 N. DIXIE DRIVE
DAYTON, OH 45414
(937) 898-4040
(800) 257-2611
FAX: (937) 898-4177
dharvey@certifiedsc.com

COMMERCIAL PARTS & SVC. OF COLUMBUS

5033 TRANSAMERICA DRIVE
COLUMBUS, OH 43228
(614) 221-0057
800-837-8327
FAX: (614) 221-3622

GCS SERVICE INC.

COLUMBUS, OH
(614) 476-3225
800-282-5406
FAX: (614) 476-1196

ELECTRICAL APPLIANCE REPAIR SVC.

5805 VALLEY BELT ROAD
CLEVELAND, OH 44131
(216) 459-8700
800-621-8259
FAX: (216) 459-8707
tomr@electapprep.com

OKLAHOMA

HAGAR RESTAURANT EQMT.

1229 W MAIN STREET
OKLAHOMA CITY, OK 73106
(405) 235-2184
800-445-1791
FAX: (405) 236-5592

OREGON

RON'S SERVICE

16364 SW 72ND AVE
PORTLAND, OR 97224
(503) 624-0890
800-851-4118
FAX: (503) 684-6107
robinson@ronsservice.com

PENNSYLVANIA

A.I.S. COMMERCIAL PARTS & SERVICE

1816 WEST 26TH STREET
ERIE, PA 16508
(814) 456-3732
800-332-3732
FAX: (814) 452-4843
aiserie@aol.com

ELMER SCHULTZ SVC.

540 NORTH 3RD STREET
PHILADELPHIA, PA 19123
(215) 627-5400
FAX: (215) 627-5408
elmer2@erols.com

GCS SERVICE INC.

PHILADELPHIA, PA
(215) 925-6217
800-441-9115
FAX: (215) 925-6208

GCS SERVICE INC.

HARRISBURG, PA
(717) 564-3282
800-367-3225
FAX: (717) 564-9286

GCS SERVICE INC.

PITTSBURGH, PA
(412) 787-1970
800-738-1221
FAX: (412) 787-5005

K & D PARTS AND SERVICE CO.

1833-41 N CAMERON STREET
HARRISBURG, PA 17103
(717) 236-9039
800-932-0503
FAX: (717) 238-4367
kdparts-service@paonline.com

CLARK SERVICE & PARTS

306 AIRPORT DRIVE
BOX 10
SMOKETOWN, PA 17576
(717) 392-5590
(717) 392-5735

SECTION 8: JACKSON MAINTENANCE & REPAIR CENTERS

RHODE ISLAND TO WISCONSIN

RHODE ISLAND

GCS SERVICE INC.
EAST PROVIDENCE, RI
(401) 434-6803
800-462-6012
FAX: (401) 438-9400

SUPERIOR KITCHEN SERVICE INC.

669 ELMWOOD AVENUE
PROVIDENCE, RI 02907
(888) 590-1899
(401) 781-1996 FAX

SOUTH CAROLINA

AUTHORIZED APPLIANCE SERVICECENTER

1811 TAYLOR ST.
COLUMBIA, SC 29202
(803) 254-8414
FAX: (803) 254-5146

AUTHORIZED APPLIANCE SERVICECENTER

2249 AUGUSTA RD.
GREENVILLE, SC 29605
(864) 235-9616
FAX: (864) 235-9623

WHALEY FOODSERVICE REPAIRS

I 26&US1
P.O. BOX 4023
WEST COLUMBIA, SC 29170
(803) 791-4420
800-877-2662
FAX: (803) 794-4630
info@whaleyfoodservice.com

WHALEY FOODSERVICE REPAIRS

748 CONGAREE ROAD
GREENVILLE, SC 29607
(864) 234-7011
800-494-2539
FAX: (864) 234-6662
info@whaleyfoodservice.com

WHALEY FOODSERVICE REPAIRS

1406-C COMMERCE PL.
MYRTLE BEACH, SC 29577
(843) 626-1866
FAX: (843) 626-2632
info@whaleyfoodservice.com

WHALEY FOODSERVICE REPAIRS

4740-A FRANCHISE STREET
N. CHARLESTON, SC 29418
(843) 760-2110
FAX: (843) 760-2255
info@whaleyfoodservice.com

SOUTH DAKOTA

GCS SERVICE INC.

MINNEAPOLIS, MN
(612) 546-4221
800-345-4221
FAX: (612) 546-4286

GENERAL PARTS, INC.

10 SOUTH 18TH STREET
FARGO, ND 58103
(701) 235-4161
(800) 279-9987
(701) 235-0539 FAX

TENNESSEE

GCS SERVICE INC.

MEMPHIS, TN
(901) 366-4587
800-262-9155
FAX: (901) 366-4588

GCS SERVICE INC.

NASHVILLE, TN
(615) 244-8050
800-831-7174
FAX: (615) 244-8885

TEXAS

ARMSTRONG REPAIR CENTER

5110 GLENMOUNT DRIVE
HOUSTON, TX 77081
(713) 666-7100
800-392-5325
FAX: (713) 661-0520
gm@armstrongrepair.com

COMMERCIAL KITCHEN REPAIR CO.

1377 N BRAZOS
P.O BOX 831128
SAN ANTONIO, TX 78207
(210) 735-2811
800-292-2120
FAX: (210) 735-7421
brock@commercialkitchen.com

GCS SERVICE INC.

DALLAS, TX
(972) 484-2954
800-442-5026
FAX: (972) 484-2531

GCS SERVICE INC.

HOUSTON, TX
(713)785-9187
800-868-6957
FAX: (713) 785-3979

GCS/STOVE PARTS

2120 SOLANA STREET
FORT WORTH, TX 76117
(817) 831-0381
800-433-1804
FAX: (817) 834-7754
bud@stoveparts.com

UTAH

LA MONICA'S RESTAURANT EQMT. SVC.

6182 SOUTH STRATLER AVENUE
MURRAY, UT 84107
(801) 263-3221
800-527-2561
FAX: (801) 263-3229
lamonica81@aol.com

VERMONT

NORTHERN PARTS & SVC.

4874 S. CATHERINE STREET
PLATTSBURGH, NY 12901
(518) 563-3200
800-634-5005
FAX: (800) 782-5424
info@northernparts.com

GCS SERVICE INC.

CHELSEA, MA
(617)889-9393
800-225-1155
FAX: (617) 889-1222

VIRGINIA

DAUBERS, INC.

7645 DYNATECH COURT
SPINGFIELD, VA 22153
(703) 866-3600
800-554-7788
FAX: (703) 866-4071
daubers@aol.com

GCS SERVICE INC.

SILVER SPRING, MD
(301) 585-7550(DC)
(410) 792-0388(BALT)
800-638-7278
FAX: (301)495-4410

GCS SERVICE INC.

RICHMOND, VA
(804) 672-1700
800-899-5949
FAX: (804) 672-2888

GCS SERVICE INC.

VIRGINIA BEACH, VA
(757) 464-3500
800-476-4278
FAX: (757) 464-4106

WASHINGTON

GCS SERVICE INC.

SEATTLE, WA
(206) 763-0353
800-211-4274
FAX: (206) 763-5943

RESTAURANT APPLIANCE SERVICE

7219 ROOSEVELT WAY, NE
SEATTLE, WA 98115
(206) 524-8200
800-433-9390
FAX: (206) 525-2890
info@restappl.com

WEST VIRGINIA

STATEWIDE SERVICE, INC.

603 MAIN AVE.
NITRO, WV 25143
(304) 755-1811
(800) 441-9739
FAX: (304) 755-4001
sws3182@aol.com

WISCONSIN

APPLIANCE SERVICE CENTER, INC.

2439 ATWOOD AVE
MADISON, WI 53704
(608) 246-3160
800-236-7440
FAX: (608) 246-2721
ascmad@execpc.com

APPLIANCE SERVICE CENTER, INC.

6843 W. BELOIT RD.
WEST ALLIS, WI 53219
(414) 543-6460
800-236-6460
FAX: (414) 543-6480
ascmil@execpc.com

APPLIANCE SERVICE CENTER

786 MORRIS AVE
GREEN BAY, WI 54304
(920) 496-9993
800-236-0871
FAX: (920) 496-9927
ascfox@execpc.com

SECTION 8: JACKSON MAINTENANCE & REPAIR CENTERS

WISCONSIN TO WYOMING/INTERNATIONAL

GENERAL PARTS, INC.

W223 N735 SARATOGA DRIVE
WAUKESHA, WI 53186
(262) 650-6666
(800) 279-9946
(262) 650-6660 FAX

WYOMING

HAWKINS COMMERCIAL APPLIANCE SERVICE

3000 S. WYANDOT ST.
ENGLEWOOD, CO 80110
(303) 781-5548
(800) 624-2117
FAX: (303) 761-5561
johns@hawkinscommercial.com

METRO APPLIANCE SERVICE

1640 S BROADWAY
DENVER, CO 80210
(303) 778-1126
800-525-3532
FAX: (303) 778-0268
metroappls@aol.com

INTERNATIONAL

GLOBAL PARTS AND SUPPLY

7758 NW 72ND ST
MIAMI, FL 33166
(305) 885-6353

H.D. SHELDON AND CO

19 UNION SQUARE, WEST
NEW YORK, NY 10003
(212) 627-1759
(212) 924-6920

CANADA

THE GARLAND GROUP

1177 KAMATO ROAD
MISSISSAUGA, ONTARIO L4W
1X4
(905) 206-8380
SALES
(905) 624-1419
FAX: (905) 624-1851
SERVICE
800-427-6668
FAX: 800-361-7745

March 13, 2007

