

INSTALLATION/OPERATION & TECHNICAL MANUAL

AJ-44T SERIES

AJ-44TE
AJ-44TG
AJ-44TS

AJ-66T SERIES

AJ-66TE
AJ-66TG
AJ-66TS

AJ-80T SERIES

AJ-80TE
AJ-80TS

AND ASSOCIATED OPTION PACKAGES INCLUDING:

SIDE LOADER

Jackson

MANUFACTURERS WARRANTY

ONE YEAR LIMITED PARTS & LABOR WARRANTY

ALL NEW JACKSON DISHWASHERS ARE WARRANTED TO THE ORIGINAL PURCHASER TO BE FREE FROM DEFECTS IN MATERIAL OR WORKMANSHIP, UNDER NORMAL USE AND OPERATION FOR A PERIOD OF (1) ONE YEAR FROM THE DATE OF PURCHASE, BUT IN NO EVENT TO EXCEED (18) EIGHTEEN MONTHS FROM THE DATE OF SHIPMENT FROM THE FACTORY.

Jackson WWS agrees under this warranty to repair or replace, at its discretion, any original part which fails under normal use due to faulty material or workmanship during the warranty period, providing the equipment has been unaltered, and has been properly installed, maintained and operated in accordance with the applicable factory instruction manual furnished with the machine and the failure is reported to the authorized service agency within the warranty period. This includes the use of factory specified genuine replacement parts, purchased directly from a Jackson authorized parts distributor or service agency. Use of generic replacement parts may create a hazard and void warranty certification.

The labor to repair or replace such failed part will be paid by Jackson WWS, within the continental United States, Hawaii and Canada, during the warranty period provided a Jackson WWS authorized service agency, or those having prior authorization from the factory, performs the service. Any repair work by persons other than a Jackson WWS authorized service agency is the sole responsibility of the customer. Labor coverage is limited to regular hourly rates, overtime premiums and emergency service charges will not be paid by Jackson WWS.

Accessory components not installed by the factory carry a (1) one year parts warranty only. Accessory components such as table limit switches, pressure regulators, pre rinse units, etc. that are shipped with the unit and installed at the site are included. Labor to repair or replace these components is not covered by Jackson WWS.

This warranty is void if failure is a direct result from shipping, handling, fire, water, accident, misuse, acts of god, attempted repair by unauthorized persons, improper installation, if serial number has been removed or altered, or if unit is used for purpose other than it was originally intended.

TRAVEL LIMITATIONS

Jackson WWS limits warranty travel time to (2) two hours and mileage to (100) one hundred miles. Jackson WWS will not pay for travel time and mileage that exceeds this, or any fees such as those for air or boat travel without prior authorization.

WARRANTY REGISTRATION CARD

The warranty registration card supplied with the machine must be returned to Jackson WWS within 30 days to validate the warranty.

REPLACEMENT PARTS WARRANTY

Jackson replacement parts are warranted for a period of 90 days from the date of installation or 180 days from the date of shipment from the factory, whichever ever occurs first.

PRODUCT CHANGES AND UPDATES

Jackson WWS reserves the right to make changes in design and specification of any equipment as engineering or necessity requires.

THIS IS THE ENTIRE AND ONLY WARRANTY OF JACKSON WWS. JACKSON'S LIABILITY ON ANY CLAIM OF ANY KIND, INCLUDING NEGLIGENCE, WITH RESPECT TO THE GOODS OR SERVICES COVERED HEREUNDER, SHALL IN NO CASE EXCEED THE PRICE OF THE GOODS OR SERVICES OR PART THEREOF WHICH GIVES RISE TO THE CLAIM.

THERE ARE NO WARRANTIES, EXPRESSED OR IMPLIED, INCLUDING FOR FITNESS OR MERCHANTABILITY, THAT ARE NOT SET FORTH HEREIN, OR THAT EXTEND BEYOND THE DURATION HEREOF. UNDER NO CIRCUMSTANCES WILL JACKSON WWS BE LIABLE FOR ANY LOSS OR DAMAGE, DIRECT OR CONSEQUENTIAL, OR FOR THE DAMAGES IN THE NATURE OF PENALTIES, ARISING OUT OF THE USE OR INABILITY TO USE ANY OF ITS PRODUCTS.

ITEMS NOT COVERED

This warranty does not cover cleaning or deliming of the unit or any component such as, but not limited to, wash arms, rinse arms or strainers at anytime. Nor does it cover adjustments such as, but not limited to timer cams, thermostats or doors, beyond 30 days from the date of installation. In addition, the warranty will only cover the replacement of wear items such as curtains, drain balls, door guides or gaskets during the first 30 days after installation. Also, not covered are conditions caused by the use of incorrect (non-Commercial) grade detergents, incorrect water temperature or pressure, or hard water conditions.



**CALL 1-888-800-5672 TO REGISTER THIS PRODUCT!
FAILURE TO DO SO WILL VOID THE WARRANTY!**

**LLAME AL 1-888-800-5672 PARA REGISTRAR ESTE PRODUCTO!
AL NO HACERLO LA GARANTIA SERA ANULADA!**

**S.V.P. APPELER 1-888-800-5672 POUR ENREGISTRER CE PRODUIT,
LA GARANTIE SERA ANNULEE POUR TOUT PRODUIT NON- ENREGISTREE**

Jackson

AJ-44TS

AJ = AJ series of rack conveyors

44 = 44" wide machine

66 = 66" wide machine

80 = 80" wide machine

TE = Electrically heated, hot water sanitizing machine

TG = Gas heated, hot water sanitizing machine

TS = Steam heated, hot water sanitizing machine

Model: _____

Serial No.: _____

Installation Date: _____

Service Rep. Name: _____

Phone No.: _____

Jackson WWS ,INC. provides technical support for all of the dishmachines detailed in this manual. We strongly recommend that you refer to this manual before making a call to our technical support staff. Please have this manual with you when you call so that our staff can refer you, if necessary, to the proper page. Technical support is available from 8:00 a.m. to 5:00 p.m. (EST), Monday through Friday. Technical support is not available on holidays. Contact technical support toll free at 1-888-800-5672. Please remember that technical support is available for service personnel only.

TABLE OF CONTENTS

<u>SECTION</u>	<u>DESCRIPTION</u>	<u>PAGE</u>
I.	SPECIFICATION INFORMATION	
	Operating Characteristics	2
	Electrical Requirements	3
	AJ-44T Electric - Left to Right	4
	AJ-44T Electric - Right to Left	5
	AJ-44T Gas - Left to Right	6
	AJ-44T Gas - Right to Left	7
	AJ-44T Steam - Left to Right	8
	AJ-44T Steam - Right to Left	9
	AJ-66T Electric - Left to Right	10
	AJ-66T Electric - Right to Left	11
	AJ-66T Gas - Left to Right	12
	AJ-66T Gas - Right to Left	13
	AJ-66T Steam - Left to Right	14
	AJ-66T Steam - Right to Left	15
	AJ-80T Electric - Left to Right	16
	AJ-80T Electric - Right to Left	17
	AJ-80T Gas - Left to Right	18
	AJ-80T Gas - Right to Left	19
	AJ-80T Steam - Left to Right	20
	AJ-80T Steam - Right to Left	21
	Side Loader (Left to Right) Dimensions	22
	Side Loader (Right to Left) Dimensions	23
	Side Loader (Installed) Dimensions	24
II.	INSTALLATION & OPERATION INSTRUCTIONS	
	Installation Instructions	26
	Curtain Installation Diagram	29
	Delimiting Operations	30
	Side Loader Installation & Operation Instructions	31
	Dishmachine Operating Instructions	32
	Detergent Control	34
	Striker Plate Limit Switch Installation Instructions	35
III.	PREVENTATIVE MAINTENANCE	
	General Maintenance	37
	Lubrication Chart for Drive Gear	38
	Drive Motor Gear Reducer Preventative Maintenance	39
IV.	TROUBLESHOOTING	41
V.	PARTS SECTION	
	AJ-44T Control Box Assembly	44
	AJ-66T/AJ-80T Control Box Assembly	46
	Motor Overload Chart	48
	Heater Box Assembly	49
	Frame Weldments/Front Dress Panels	52
	Prewash Plumbing Assembly	53
	Incoming Plumbing Assembly	55
	Incoming Plumbing Assembly (TG Series)	57
	Solenoid Valve & Vacuum Breaker Repair Parts	58
	Steam Unit Wash Tank Coil Assembly	59
	Steam Plumbing (Left to Right Models)	60
	Steam Plumbing (Right to Left Models)	61
	Gas Coil Assembly (TG Models)	62

TABLE OF CONTENTS

<u>SECTION</u>	<u>DESCRIPTION</u>	<u>PAGE</u>
V.	PARTS SECTION (CONTINUED)	
	Rinse Booster Tank Assembly (TG Models)	63
	Recirculating Pump Assembly (TG Models)	64
	Hose Connections (TG Models)	65
	AJ-44T Series Drain Plumbing Assemblies	66
	AJ-66T Series Drain Plumbing Assemblies	67
	AJ-80T Series Drain Plumbing Assemblies	68
	AJ-66TG Series (Left to Right) Drain Plumbing Assembly	69
	AJ-66TG Series (Right to Left) Drain Plumbing Assembly	70
	Drain Quench Assembly	71
	Motor Assemblies	72
	Prewash & Wash Pump Weldments	73
	Prewash Arm/Manifold Assembly	74
	Wash Arm/Manifold Assembly	75
	Final Rinse Assembly	76
	Drive Assembly	77
	Door Assemblies	79
	Pawl Bar Roller Bracket	80
	AJ-44T & AJ-66T Pawl Bar Assemblies	81
	AJ-80T Pawl Bar Assemblies	82
	AJ-44T Rack Rail Assembly	83
	AJ-66T Rack Rail Assemblies	84
	AJ-80T Rack Rail Assemblies	85
	Miscellaneous Parts & Weldments	86
	Strainers	87
	Float Switch Components/Scrap Baskets	88
	Curtains/Tub Magnets	89
	Vent Cowl Assembly/Vent Scoop Option	90
	Exhaust Fan Control/Limit Switch Options	91
	SIDE LOADER SECTION	
	Side Loader Track Assembly/Leg Replacements	92
	Side Loader Pawl Bar Assemblies/Strainer/Magnet	93
	Side Loader Pawl Bar Associated Parts	94
	Side Loader Vent Cowl Option	95
	Rinse Fill Option	96
VI.	ELECTRICAL SCHEMATICS	
	AJ-44TE	
	208-230 Volt, 60 Hz, 1 Phase	98
	208-230 Volt, 60 Hz, 3 Phase	99
	460 Volt, 60 Hz, 3 Phase	100
	AJ-44TG	
	208-230 Volt, 60 Hz, 1 Phase	101
	208-230 Volt, 60 Hz, 3 Phase	102
	460 Volt, 60 Hz, 3 Phase	103
	AJ-44TS	
	208-230 Volt, 60 Hz, 1 Phase	104
	208-230 Volt, 60 Hz, 3 Phase	105
	460 Volt, 60 Hz, 3 Phase	106
	AJ-66TE & AJ-80TE	
	208-230 Volt, 60 Hz, 1 Phase	107
	208-230 Volt, 60 Hz, 3 Phase	108
	460 Volt, 60 Hz, 3 Phase	109

TABLE OF CONTENTS

<u>SECTION</u>	<u>DESCRIPTION</u>	<u>PAGE</u>
VII.	ELECTRICAL SCHEMATICS	
	AJ-66TG & AJ-80TG	
	208-230 Volt, 60 Hz, 1 Phase	110
	208-230 Volt, 60 Hz, 3 Phase	111
	460 Volt, 60 Hz, 3 Phase	112
	AJ-66TS & AJ-80TS	
	208-230 Volt, 60 Hz, 1 Phase	113
	208-230 Volt, 60 Hz, 3 Phase	114
	460 Volt, 60 Hz, 3 Phase	115
	Conveyor Side Loader/Drain Quench Schematics	116
	Exhaust Fan Hook-Up Schematics	117
VIII.	JACKSON MAINTENANCE & REPAIR CENTERS	118

SECTION 1: SPECIFICATION INFORMATION

SECTION 1: SPECIFICATION INFORMATION

OPERATING CHARACTERISTICS

RACKS PER HOUR:

AJ-44-66-80TE/TG/TS 204

DISHES OR GLASSES PER HOUR:

AJ-44-66-80TE/TG/TS 5100

PREWASH TANK CAPACITY (GALLONS):

AJ-66TE/TG/TS 17.25
AJ-80TE/TG/TS 17.25

WASH TANK CAPACITY (GALLONS):

AJ-44-66-80TE/TG/TS 20.4

PREWASH PUMP CAPACITY (GPM):

AJ-66TE/TG/TS 120
AJ-80TE/TG/TS 270

WASH PUMP CAPACITY

GALLONS PER MINUTE (ALL MODELS): 270

VENTING REQUIREMENTS (CFM)(100% CAP.):

INPUT END 200
OUTPUT END 400
TOTAL 600

CONVEYOR SPEED (FPM):

AJ-44-66-80TE/TG/TS MACHINES 5.7

GALLONS PER RACK:

AJ-44-66-80TE/TG/TS MACHINES .69

WATER TEMPERATURES:**AJ-44-66-80TE/TG/TS MODELS:**

PREWASH (RECOMMENDED) (AJ-66 & AJ-80) 110-140°F
WASH (MINIMUM) 160°F
RINSE (MINIMUM) 180°F

FLOW PRESSURE (PSI) 20 ± 5

FLOWRATE (GPM):

AJ-44-66-80TE/TG/TS 3.1

STEAM COIL TANK HEAT (TS MODELS ONLY):

STEAM INLET PRESSURE (PSIG) 10-20
STEAM CONNECTION NPT 3/4"
CONSUMPTION @ 15 PSIG (lbs/hr): 60

MOTOR ELECTRICAL CHARACTERISTICS:

DRIVE MOTOR HP 1/4
WASH MOTOR HP 2
POWER RINSE MOTOR HP 2
PREWASH MOTOR HP:
AJ-66TE/TG/TS MODELS 1
AJ-80TE/TG/TS MODELS 2

NOTE: Always refer to the machine data plate for specific electrical and water requirements. The material provided on this page is for reference only and may be subject to change without notice.

SECTION 1: SPECIFICATION INFORMATION

ELECTRICAL REQUIREMENTS

NOTE: Typical Electrical Circuit is based upon (1) 125% of the full amperage load of the machine and (2) typical fixed-trip circuit breaker sizes as listed in the NEC 2002 Edition. Local codes may require more stringent protection than what is displayed here. Always verify with your electrical service contractor that your circuit protection is adequate and meets all applicable national and local codes. These numbers are provided in this manual simply for reference and may change without notice at any given time.

<u>MODEL</u>	<u>VOLTS</u>	<u>PH</u>	<u>HZ</u>	<u>RINSE HEATER RATINGS</u>	<u>TOTAL AMPS</u>	<u>TYPICAL ELECTRICAL CIRCUIT</u>
AJ-44TE	208	1	60	N/A	97 A	125 AMP
AJ-44TE	230	1	60	N/A	89 A	125 AMP
AJ-44TE	208	3	60	N/A	57 A	80 AMP
AJ-44TE	230	3	60	N/A	49 A	70 AMP
AJ-44TE	460	3	60	N/A	25 A	35 AMP
AJ-44TG	208	1	60	N/A	12 A	15 AMP
AJ-44TG	230	1	60	N/A	12 A	15 AMP
AJ-44TG	208	3	60	N/A	8 A	15 AMP
AJ-44TG	230	3	60	N/A	8 A	15 AMP
AJ-44TG	460	3	60	N/A	5 A	15 AMP
AJ-44TS	208	1	60	N/A	11 A	15 AMP
AJ-44TS	230	1	60	N/A	11 A	15 AMP
AJ-44TS	208	3	60	N/A	7 A	15 AMP
AJ-44TS	230	3	60	N/A	7 A	15 AMP
AJ-44TS	460	3	60	N/A	4 A	15 AMP
AJ-66TE	208	1	60	N/A	103 A	150 AMP
AJ-66TE	230	1	60	N/A	95 A	125 AMP
AJ-66TE	208	3	60	N/A	61 A	80 AMP
AJ-66TE	230	3	60	N/A	52 A	70 AMP
AJ-66TE	460	3	60	N/A	26 A	35 AMP
AJ-66TG	208	1	60	N/A	18 A	25 AMP
AJ-66TG	230	1	60	N/A	18 A	25 AMP
AJ-66TG	208	3	60	N/A	12 A	15 AMP
AJ-66TG	230	3	60	N/A	12 A	15 AMP
AJ-66TG	460	3	60	N/A	7 A	15 AMP
AJ-66TS	208	1	60	N/A	17 A	25 AMP
AJ-66TS	230	1	60	N/A	17 A	25 AMP
AJ-66TS	208	3	60	N/A	11 A	15 AMP
AJ-66TS	230	3	60	N/A	11 A	15 AMP
AJ-66TS	460	3	60	N/A	6 A	15 AMP
AJ-80TE	208	1	60	N/A	106 A	150 AMP
AJ-80TE	230	1	60	N/A	97 A	125 AMP
AJ-80TE	208	3	60	N/A	63 A	80 AMP
AJ-80TE	230	3	60	N/A	58 A	80 AMP
AJ-80TE	460	3	60	N/A	29 A	40 AMP
AJ-80TG	208	1	60	N/A	19 A	25 AMP
AJ-80TG	230	1	60	N/A	19 A	25 AMP
AJ-80TG	208	3	60	N/A	13 A	20 AMP
AJ-80TG	230	3	60	N/A	13 A	20 AMP
AJ-80TG	460	3	60	N/A	7 A	15 AMP
AJ-80TS	208	1	60	N/A	19 A	25 AMP
AJ-80TS	230	1	60	N/A	19 A	25 AMP
AJ-80TS	208	3	60	N/A	13 A	20 AMP
AJ-80TS	230	3	60	N/A	13 A	20 AMP
AJ-80TS	460	3	60	N/A	7 A	15 AMP

SECTION 1: SPECIFICATION INFORMATION

AJ-44T ELECTRIC - LEFT TO RIGHT

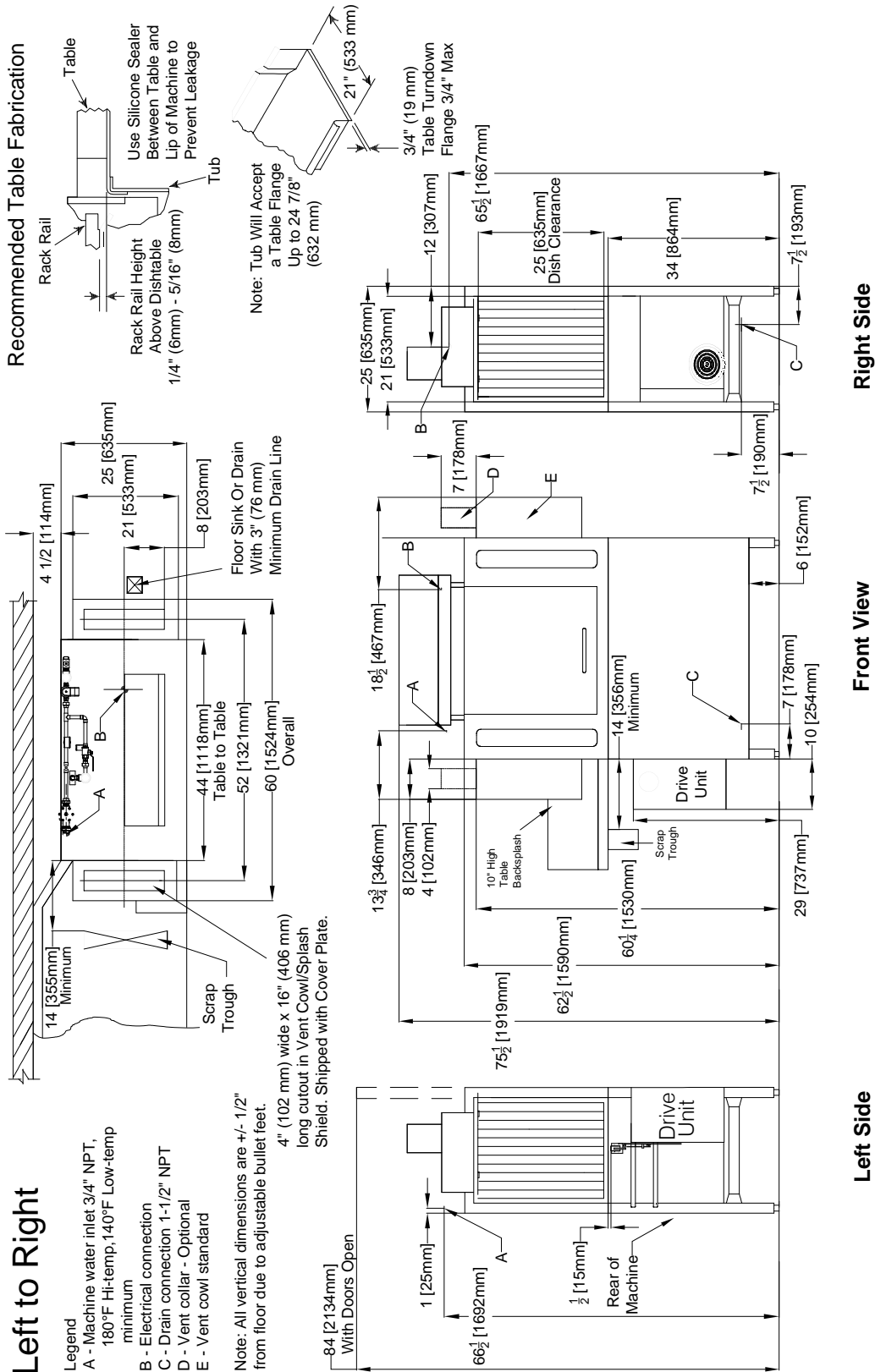

SECTION 1: SPECIFICATION INFORMATION

AJ-44T ELECTRIC - RIGHT TO LEFT

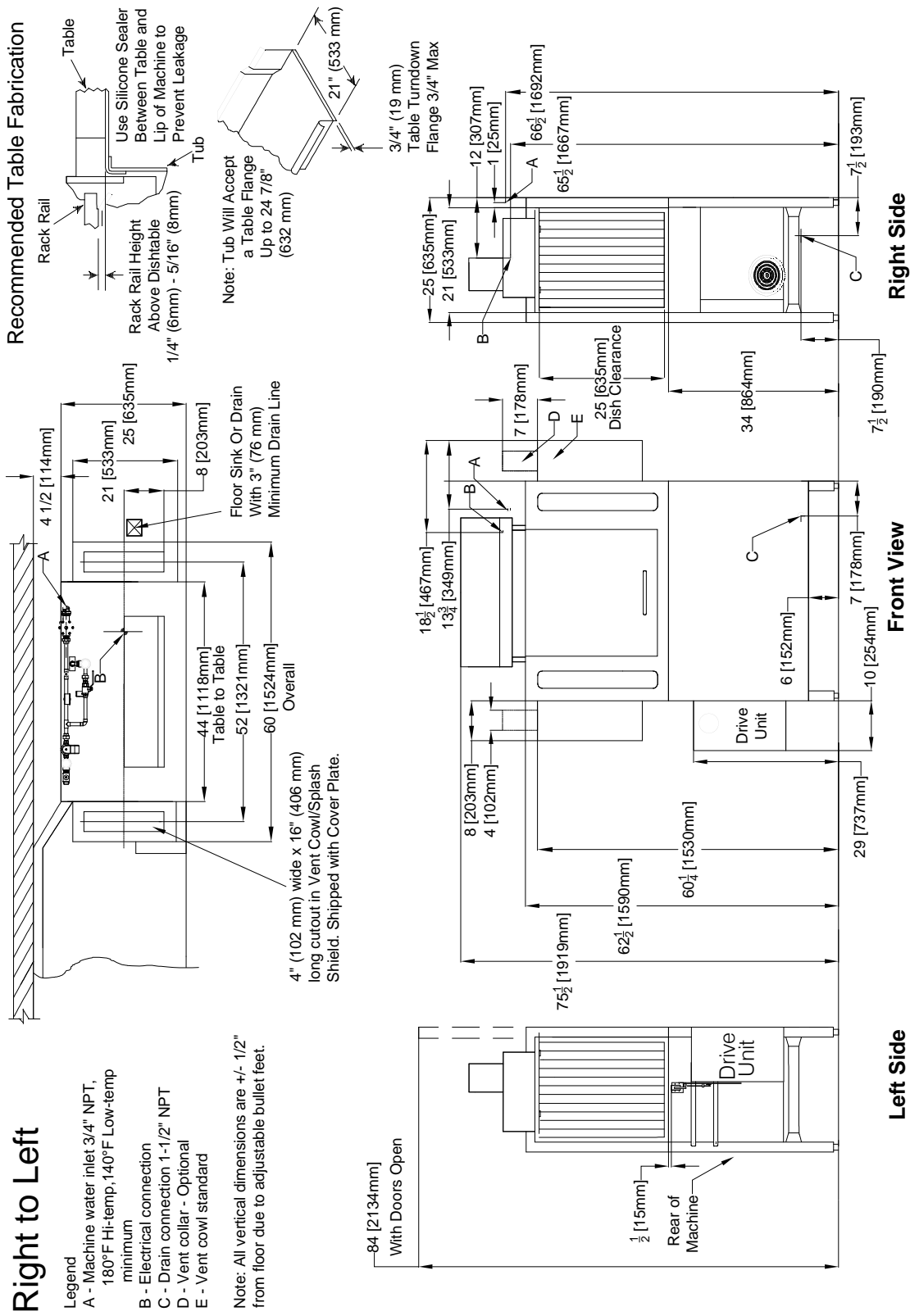

SECTION 1: SPECIFICATION INFORMATION

AJ-44T GAS - LEFT TO RIGHT

Left to Right

Legend to Drawing

- A - Machine water inlet 3/4" NPT, 180°F Hi-temp, 140°F Low-temp minimum
- B - Electrical connection
- C - Drain connection 1-1/2" NPT
- D - Vent collar - Optional
- E - Vent cowl standard
- F - 3/4" NPT 180°F Water Inlet for wash tank fill, final rinse, & tank heating. From gas booster heater. Interconnecting hose provided by manufacturer.
- G - 3/4" NPT 140°F Water Inlet for gas booster heater.
- H - 3/4" NPT 180°F Water Outlet connection to line on dishmachine. Connection hose provided by manufacturer.
- J - 3/4" NPT Gas Connection
- K - 4" OD Vent pipe connection. Flue to be installed to meet local codes by installing contractor.

Note: All vertical dimensions are +/- 1/2" from floor due to adjustable bullet feet.

Recommended Table Fabrication

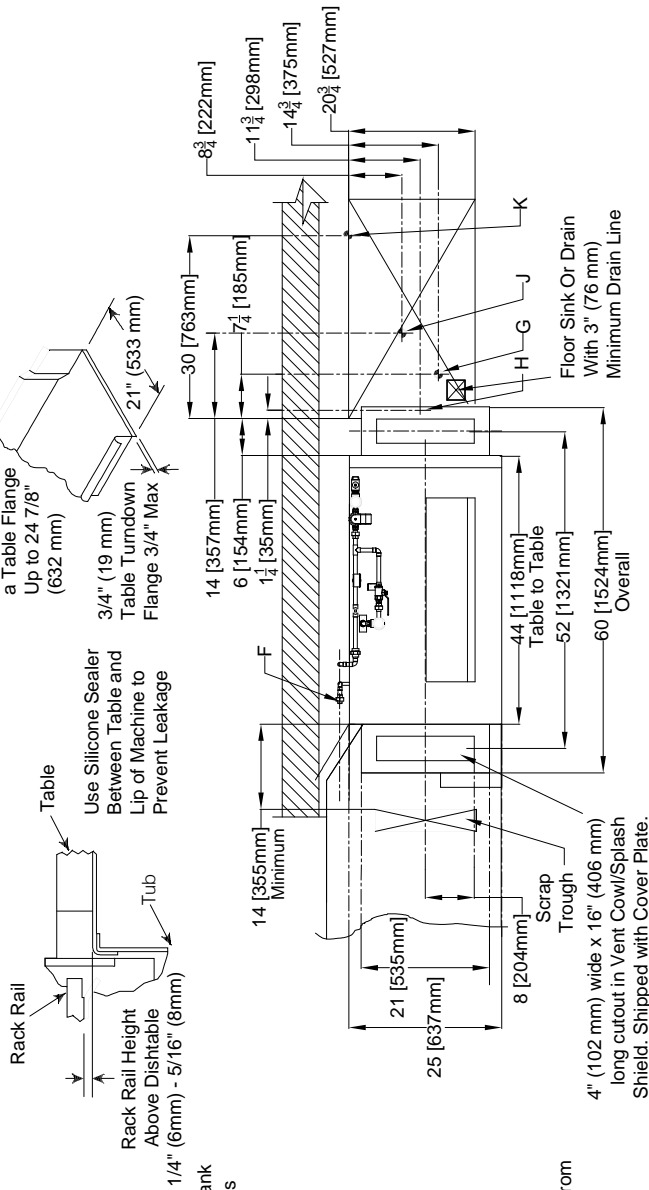

Note: Tub Will Accept a Table Flange Up to 24 7/8" (632 mm)

3/4" (19 mm) Table Turndown Flange 3/4" Max

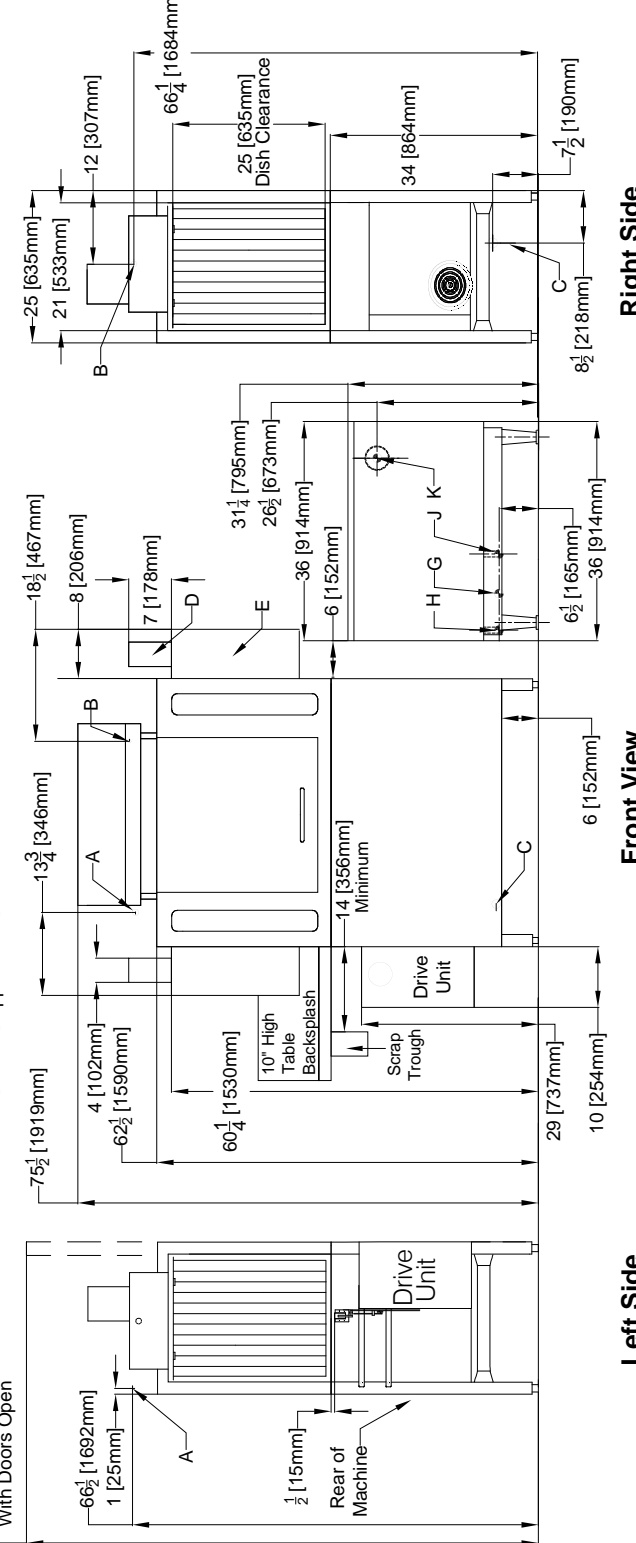
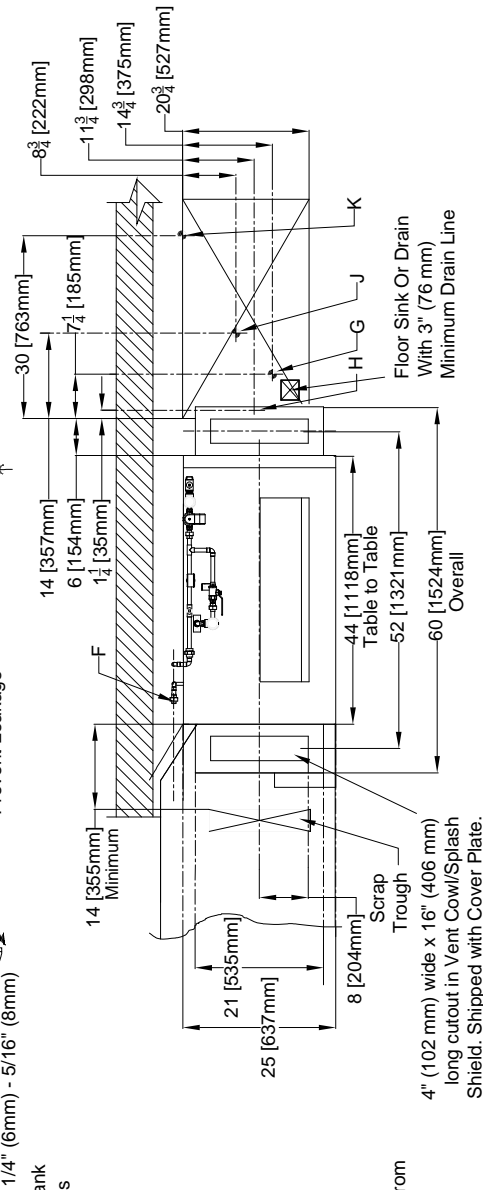

SECTION 1: SPECIFICATION INFORMATION

AJ-44T GAS - RIGHT TO LEFT

Right to Left

Legend to Drawing

- A - Machine water inlet 3/4" NPT, 180°F Hi-temp, 140°F Low-temp minimum
- B - Electrical connection
- C - Drain connection 1-1/2" NPT
- D - Vent collar - Optional
- E - Vent cowl standard
- F - 3/4" NPT 180°F Water Inlet for wash tank fill, final rinse, & tank heating. From gas booster heater. Interconnecting hose provided by manufacturer.
- G - 3/4" NPT 140°F Water inlet for gas booster heater.
- H - 3/4" NPT 180°F Water Outlet connection to line on dishmachine. Connection hose provided by manufacturer.
- J - 3/4" NPT Gas Connection
- K - 4" OD Vent pipe connection. Flue to be installed to meet local codes by installing contractor.

Note: All vertical dimensions are +/- 1/2" from floor due to adjustable bullet feet.

Recommended Table Fabrication

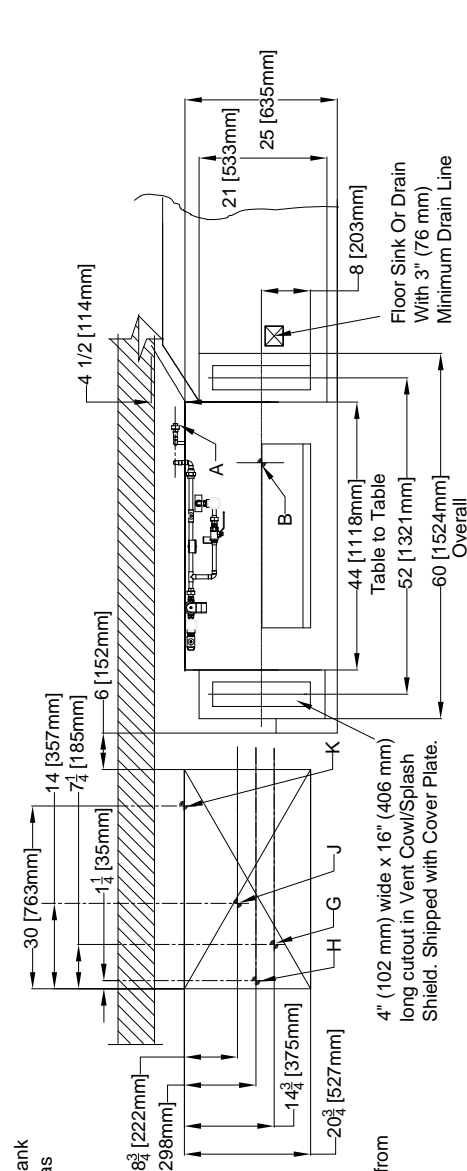
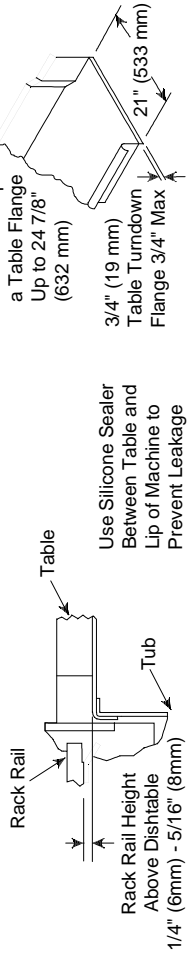

Right Side

Front View

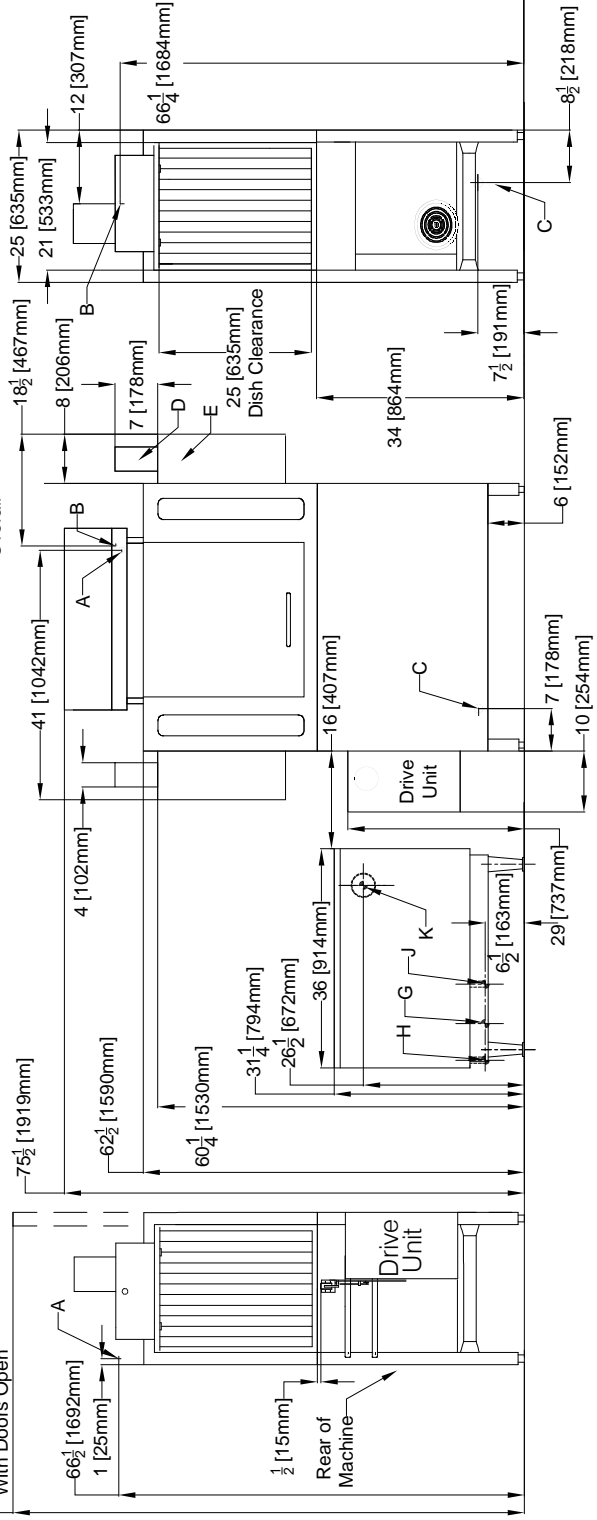

Left Side

SECTION 1: SPECIFICATION INFORMATION

AJ-44T STEAM - LEFT TO RIGHT

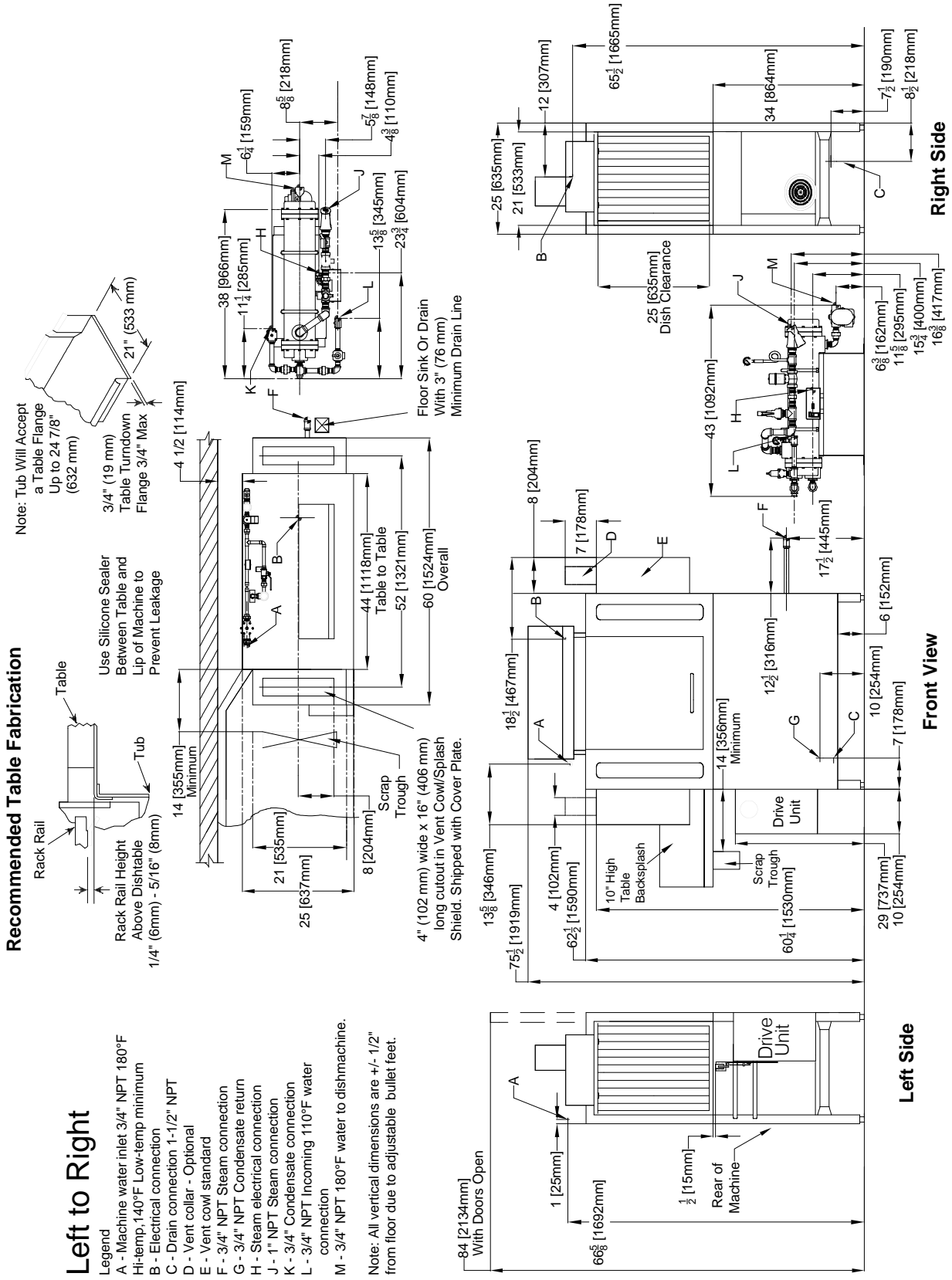

SECTION 1: SPECIFICATION INFORMATION

AJ-44T STEAM - RIGHT TO LEFT

Right to Left

Legend

- A - Machine water inlet 3/4" NPT 180°F Hi-temp, 140°F Low-temp minimum
- B - Electrical connection
- C - Drain connection 1-1/2" NPT
- D - Vent collar - Optional
- E - Vent cowl standard
- F - 3/4" NPT Steam connection
- G - 3/4" NPT Condensate return
- H - Steam electrical connection
- J - 1" NPT Steam connection
- K - 3/4" Condensate connection
- L - 3/4" NPT Incoming 110°F water connection
- M - 3/4" NPT 180°F water to dishmachine.

Note: All vertical dimensions are +/- 1/2" from floor due to adjustable bullet feet.

Recommended Table Fabrication

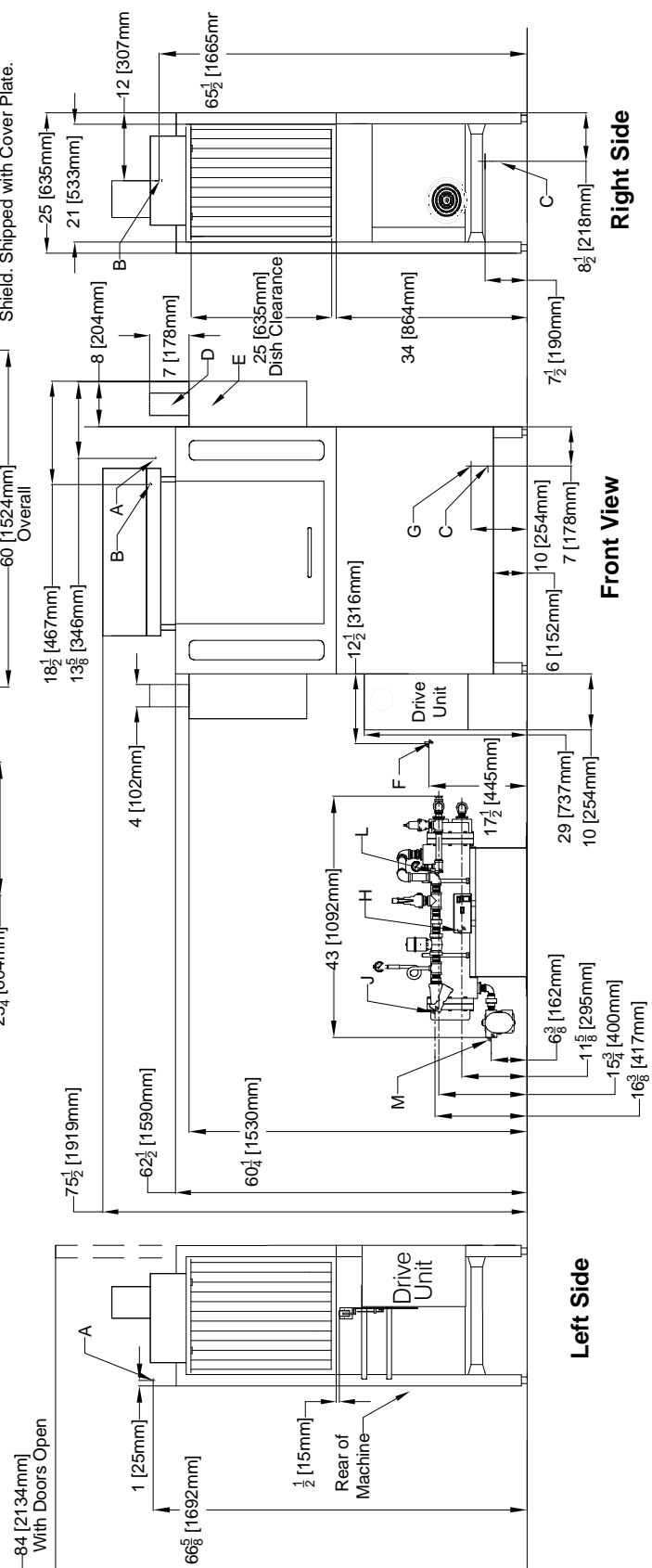
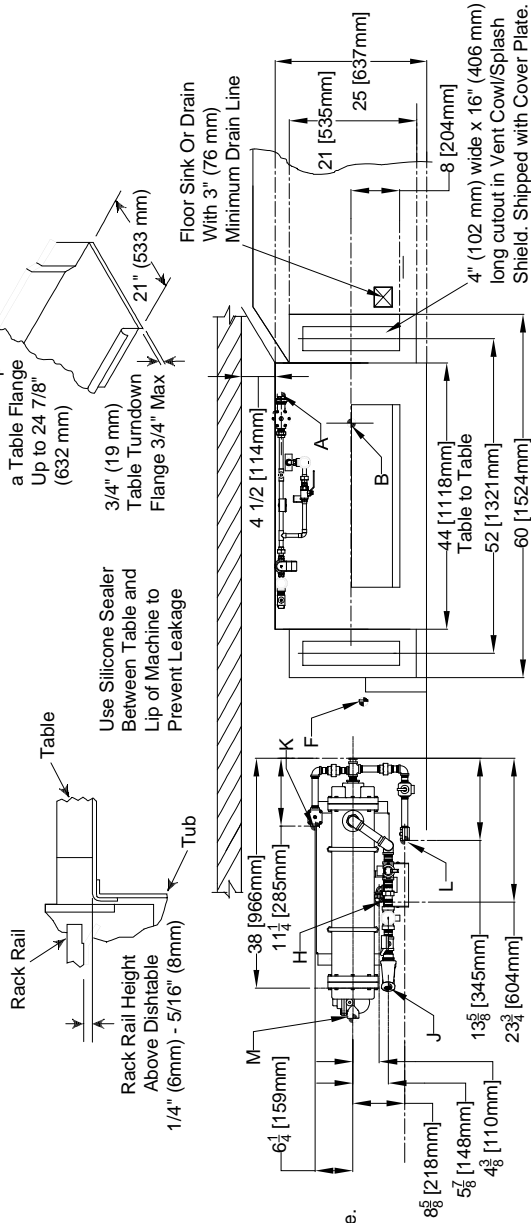

SECTION 1: SPECIFICATION INFORMATION

AJ-66T ELECTRIC - LEFT TO RIGHT

Left to Right

Legend

- A - Machine water inlet 3/4" NPT, 180°F Hi-temp, 140°F Low-temp minimum
- B - Electrical connection
- C - Drain connection 1-1/2" NPT
- D - Vent collar - Optional
- E - Vent cowl standard
- F - Prewash water inlet 3/4" NPT 110°F-140°F
- G - Cold water thermostat plumbing connection 3/4" NPT - Optional

Note: All vertical dimensions are +/- 1/2" from floor due to adjustable bullet feet.

Recommended Table Fabrication

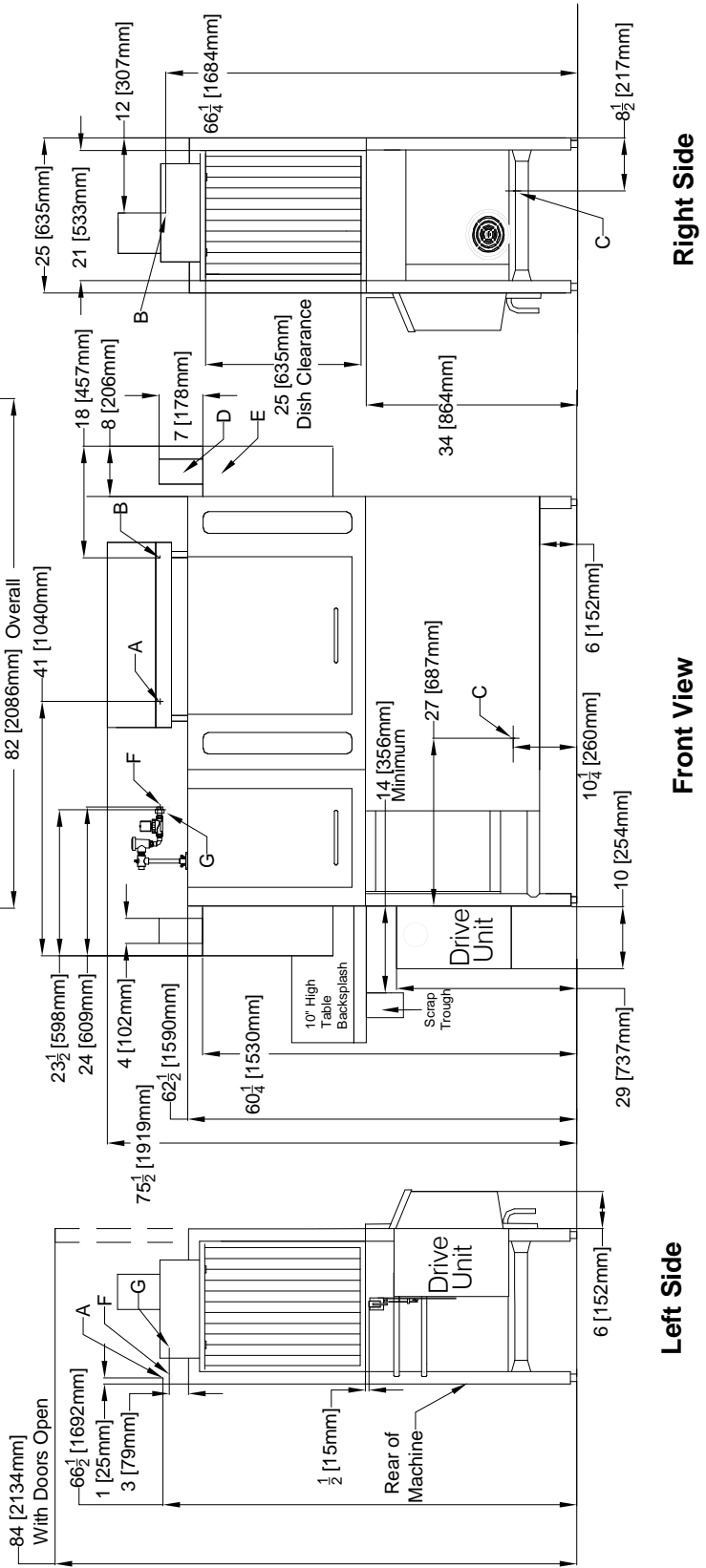
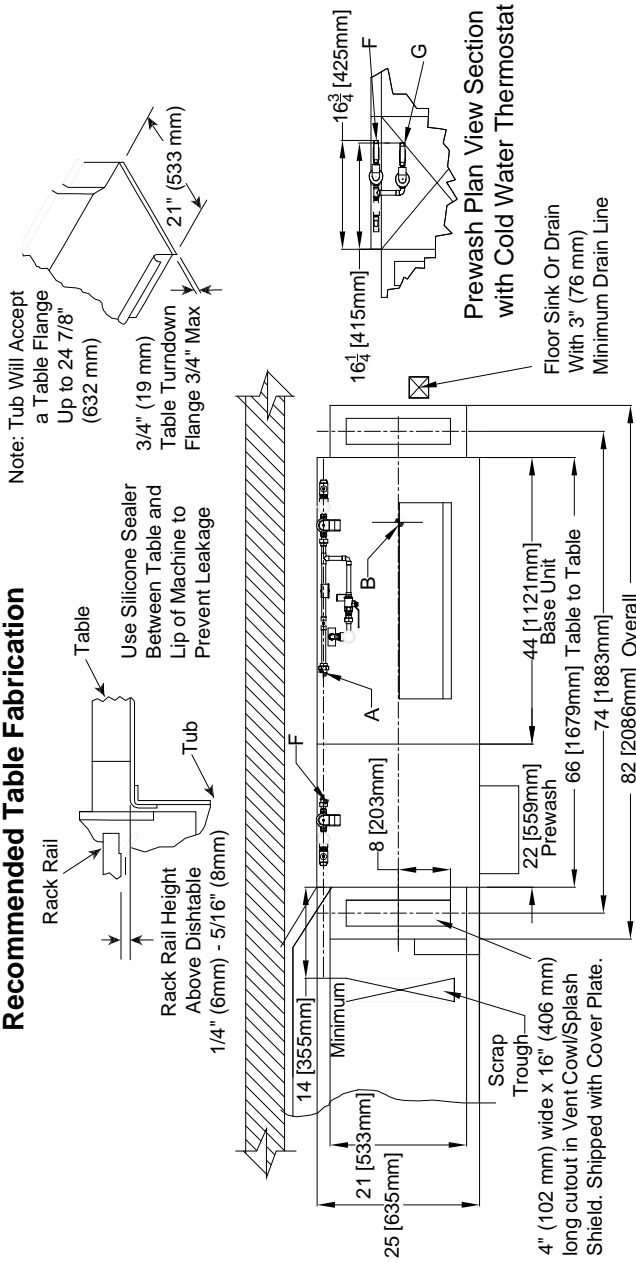

SECTION 1: SPECIFICATION INFORMATION

AJ-66T ELECTRIC - RIGHT TO LEFT

Right to Left

Legend

- A - Machine water inlet 3/4" NPT, 180°F Hi-temp, 140°F Low-temp minimum
- B - Electrical connection
- C - Drain connection 1-1/2" NPT
- D - Vent collar - Optional
- E - Vent cowl standard
- F - Prewash water inlet 3/4" NPT 110°F-140°F
- G - Cold water thermostat plumbing connection 3/4" NPT - Optional

Note: All vertical dimensions are +/- 1/2" from floor due to adjustable bullet feet.

4" (102 mm) wide x 16" (406 mm) long cutout in Vent Cowl/Splash Shield. Shipped with Cover Plate.

Recommended Table Fabrication

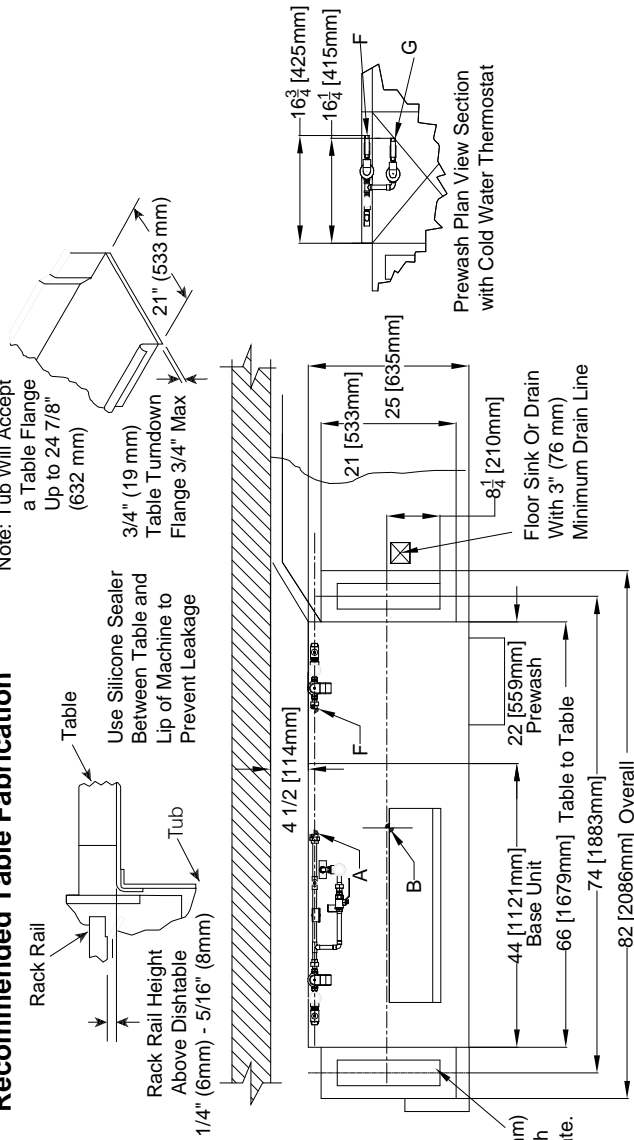

Note: Tub Will Accept a Table Flange Up to 24 7/8" (632 mm)

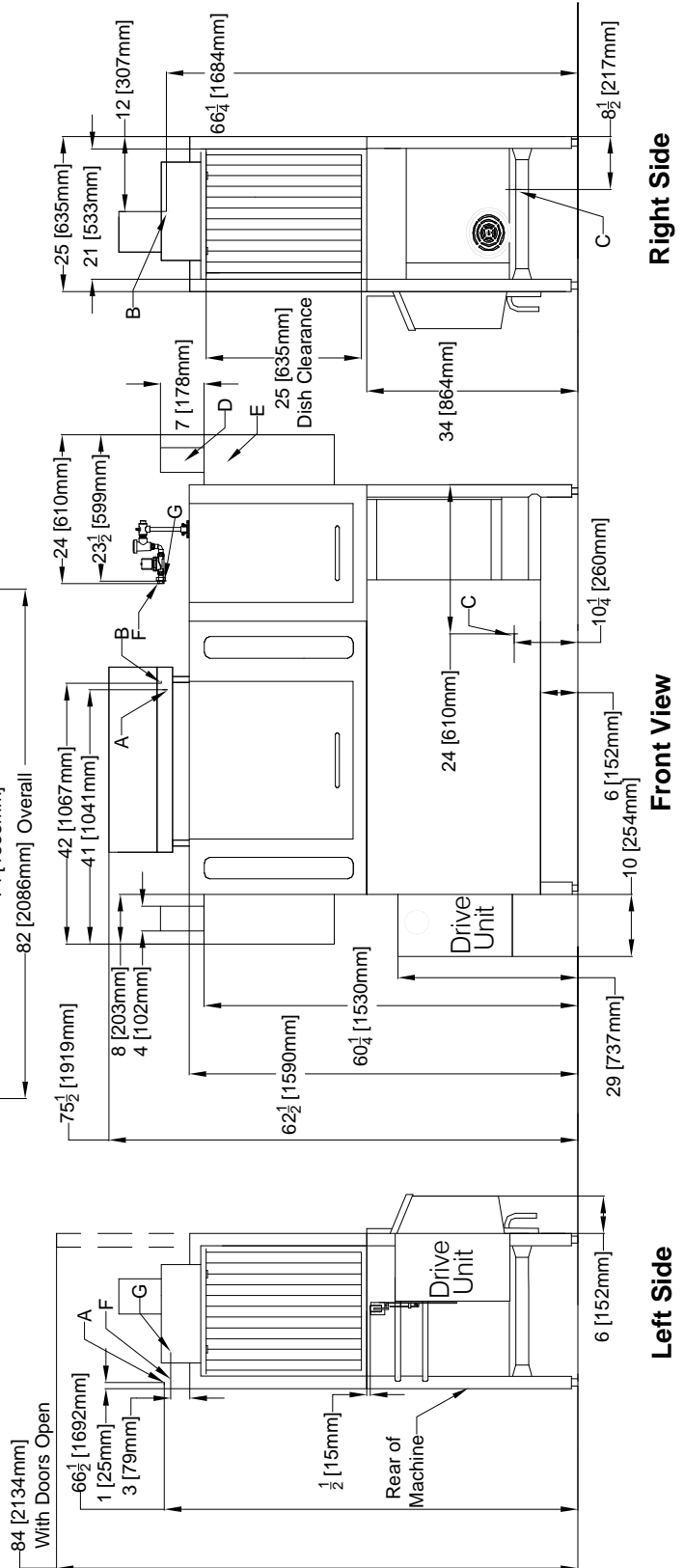
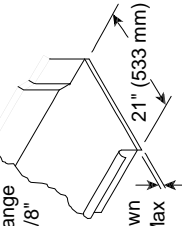

SECTION 1: SPECIFICATION INFORMATION

AJ-66T GAS - LEFT TO RIGHT

Left to Right

Legend

- A - Machine water inlet 3/4" NPT, 180°F Hi-temp, 140°F Low-temp minimum
- B - Electrical connection
- C - Drain connection 1-1/2" NPT
- D - Vent collar - Optional
- E - Vent cowl standard
- F - 3/4" NPT 180°F Water Inlet for wash tank fill, final rinse, & tank heating. From gas booster heater. Interconnecting hose provided by manufacturer.
- G - 3/4" NPT 140°F Water inlet for gas booster heater.
- H - 3/4" NPT 180°F Water Outlet connection to line on dishmachine. Connection hose provided by manufacturer.
- J - 3/4" NPT Gas Connection
- K - 4" OD Vent pipe connection. Flue to be installed to meet local codes by installing contractor.
- L - Prewash water inlet 3/4" NPT 110°F-140°F
- M - Cold water thermostat plumbing connection 3/4" NPT - Optional

Recommended Table Fabrication

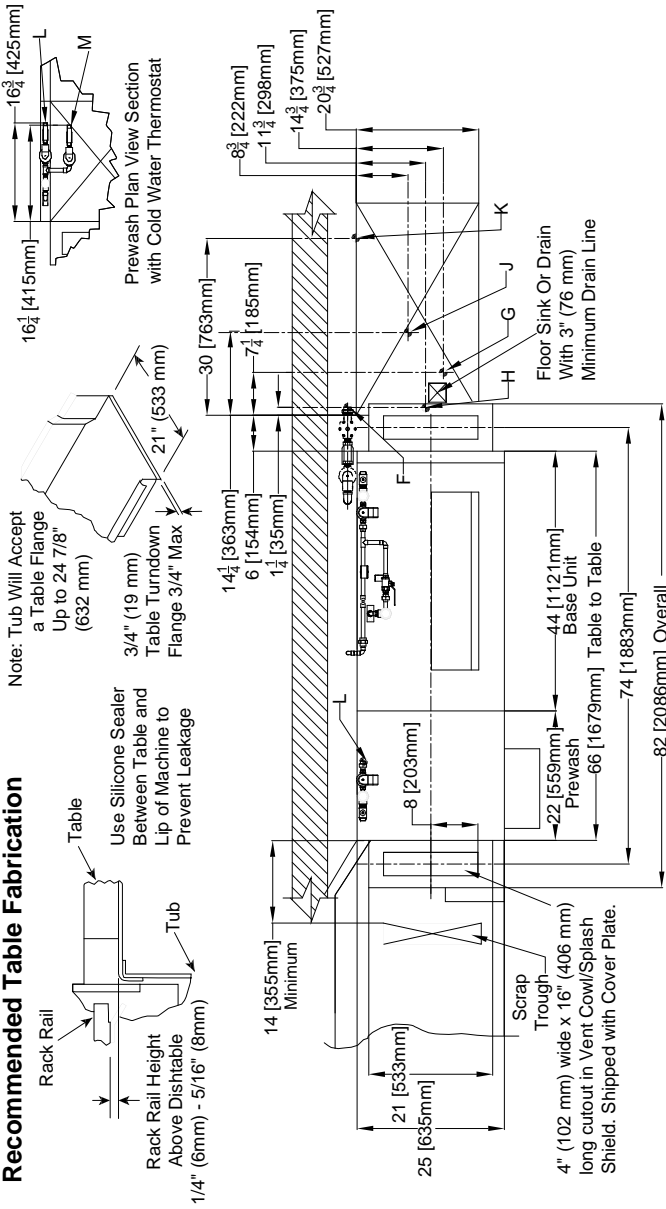

Note: All vertical dimensions are +/- 1/2" from floor due to adjustable bullet feet.

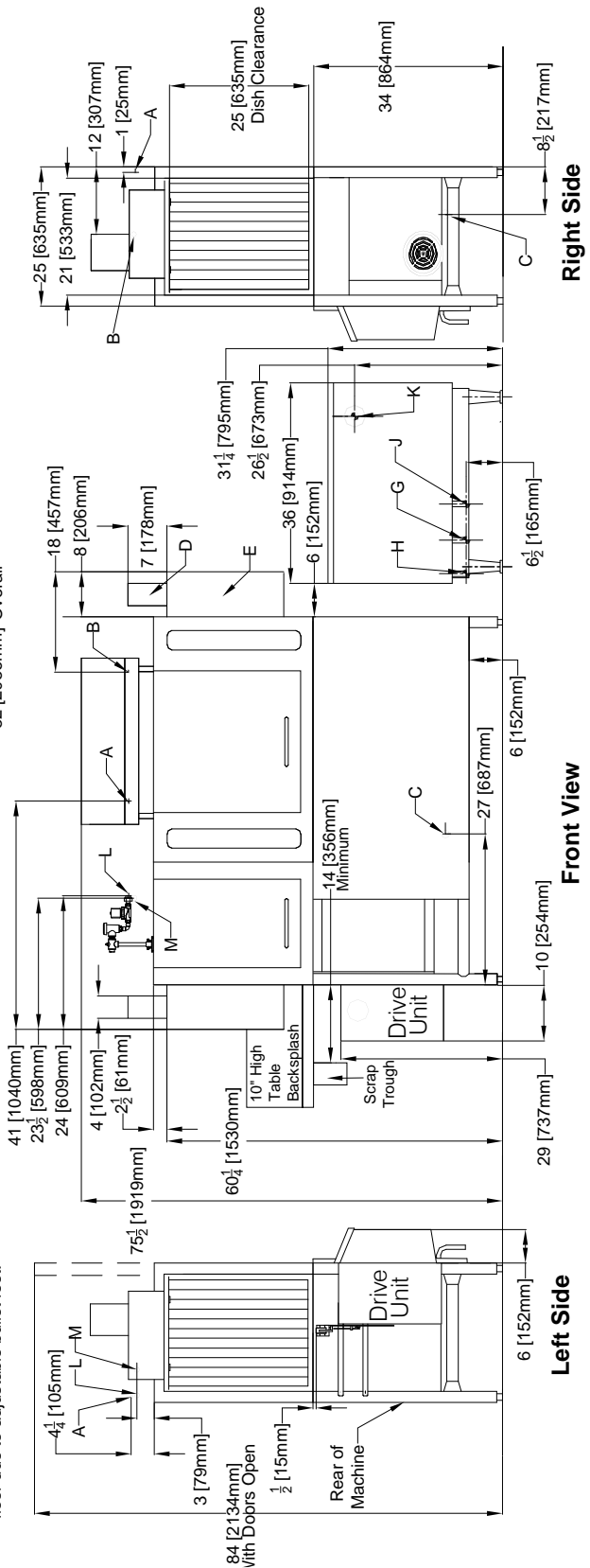

SECTION 1: SPECIFICATION INFORMATION

AJ-66T GAS - RIGHT TO LEFT

Left to Right

Legend

- A - Machine water inlet 3/4" NPT, 180°F Hi-temp, 140°F Low-temp minimum
- B - Electrical connection
- C - Drain connection 1-1/2" NPT
- D - Vent collar - Optional
- E - Vent cowl standard
- F - 3/4" NPT 180°F Water Inlet for wash tank fill, final rinse, & tank heating. From gas booster heater. Interconnecting hose provided by manufacturer.
- G - 3/4" NPT 140°F Water inlet for gas booster heater.
- H - 3/4" NPT 180°F Water Outlet connection to line on dishmachine. Connection hose provided by manufacturer.
- J - 3/4" NPT Gas Connection
- K - 4" OD Vent pipe connection. Flue to be installed to meet local codes by installing contractor.
- L - Prewash water inlet 3/4" NPT 110°F-140°F
- M - Cold water thermostat plumbing connection 3/4" NPT - Optional

Note: All vertical dimensions are +/- 1/2" from floor due to adjustable bullet feet.

Recommended Table Fabrication

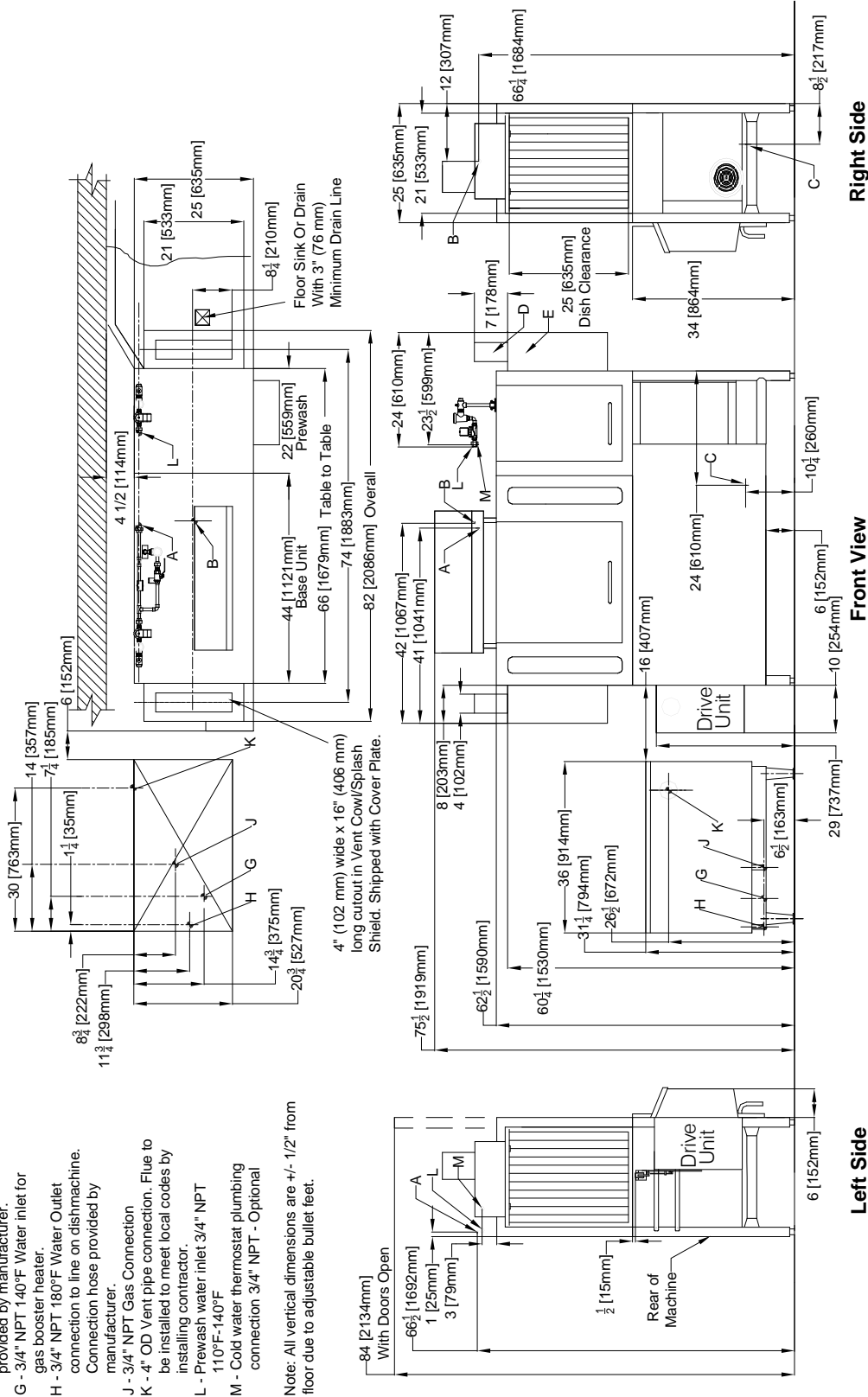
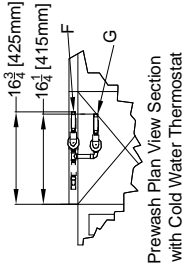

SECTION 1: SPECIFICATION INFORMATION

AJ-66T STEAM - LEFT TO RIGHT

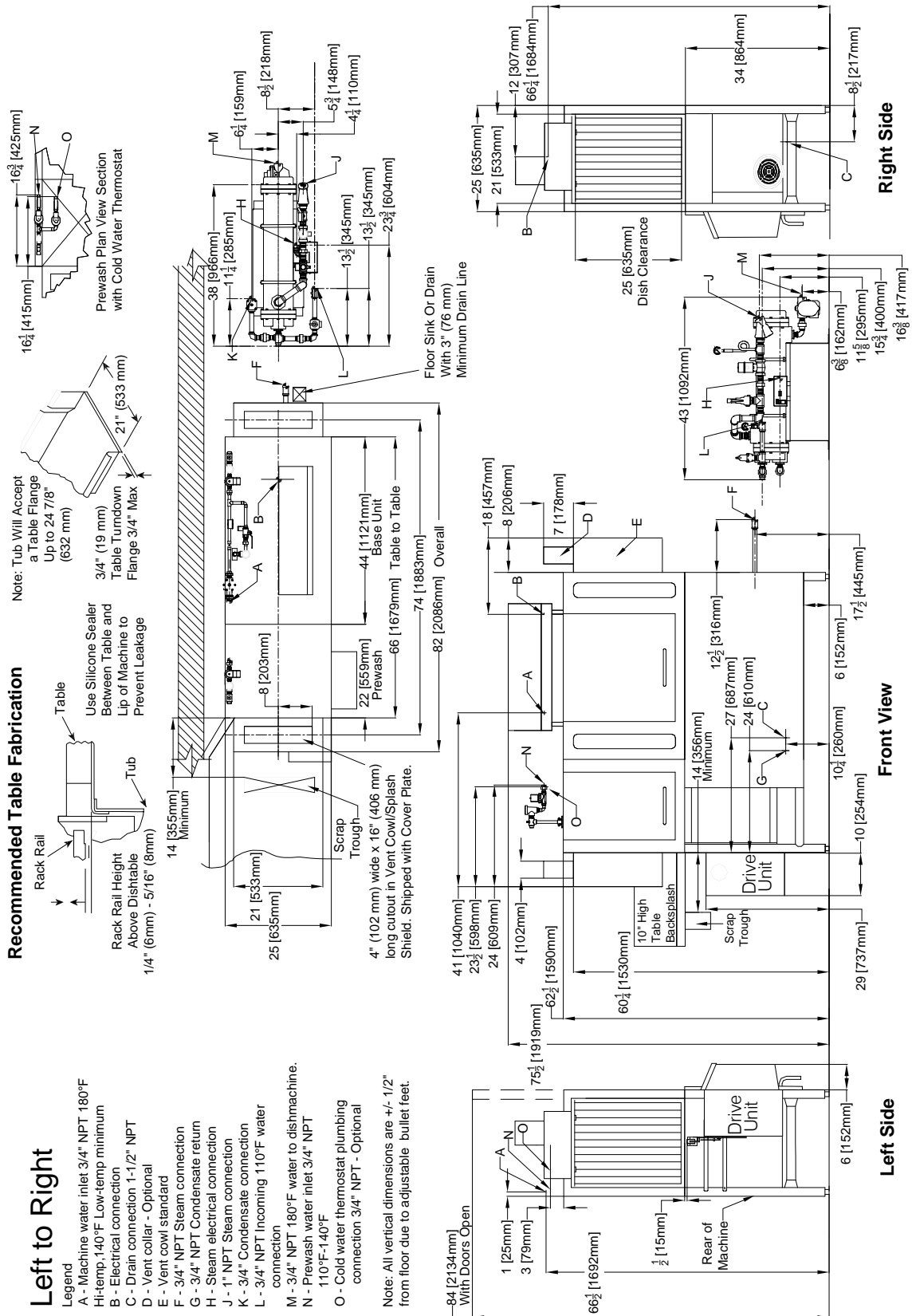

SECTION 1: SPECIFICATION INFORMATION

AJ-66T STEAM - RIGHT TO LEFT

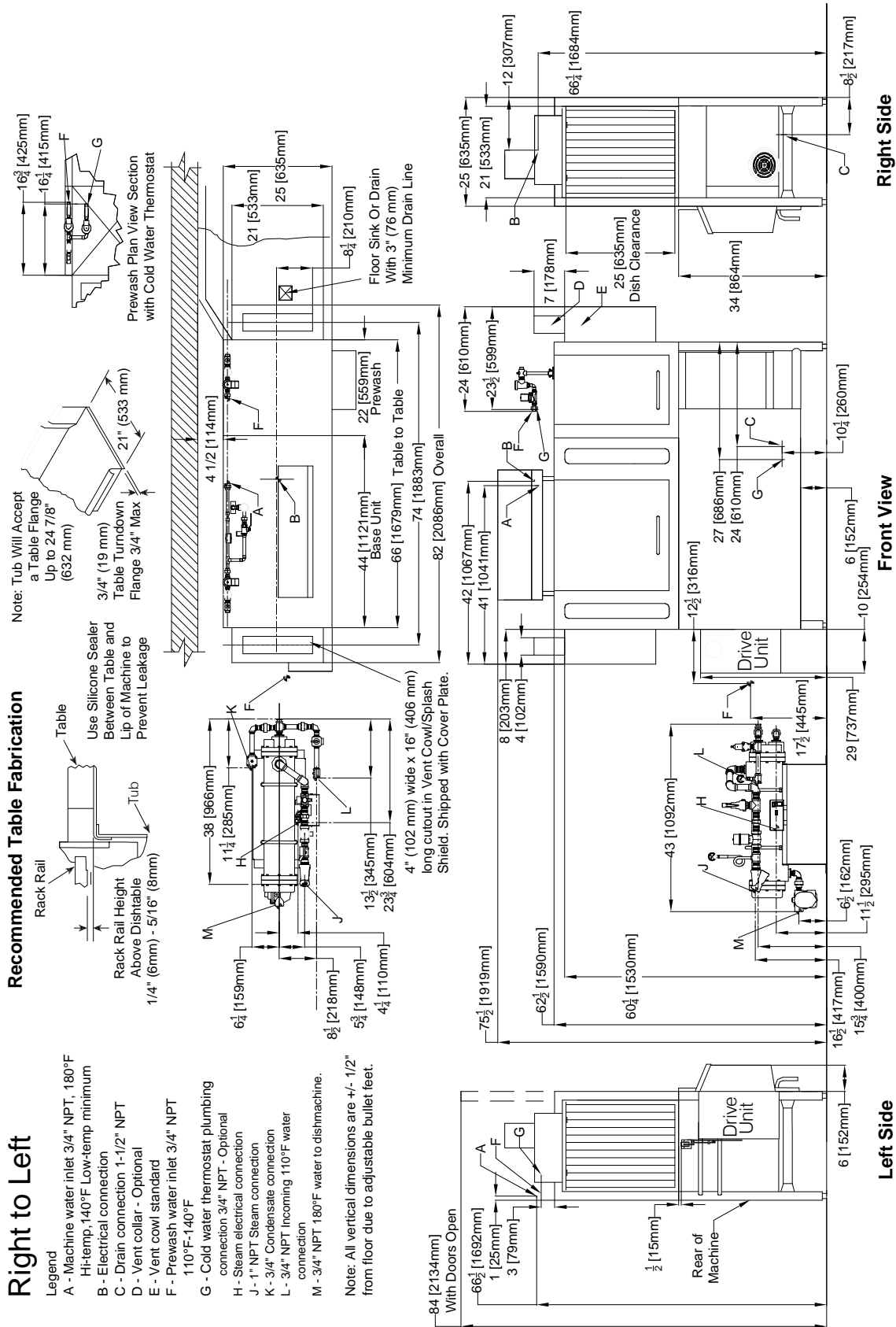

SECTION 1: SPECIFICATION INFORMATION

AJ-80T ELECTRIC - LEFT TO RIGHT

Recommended Table Fabrication

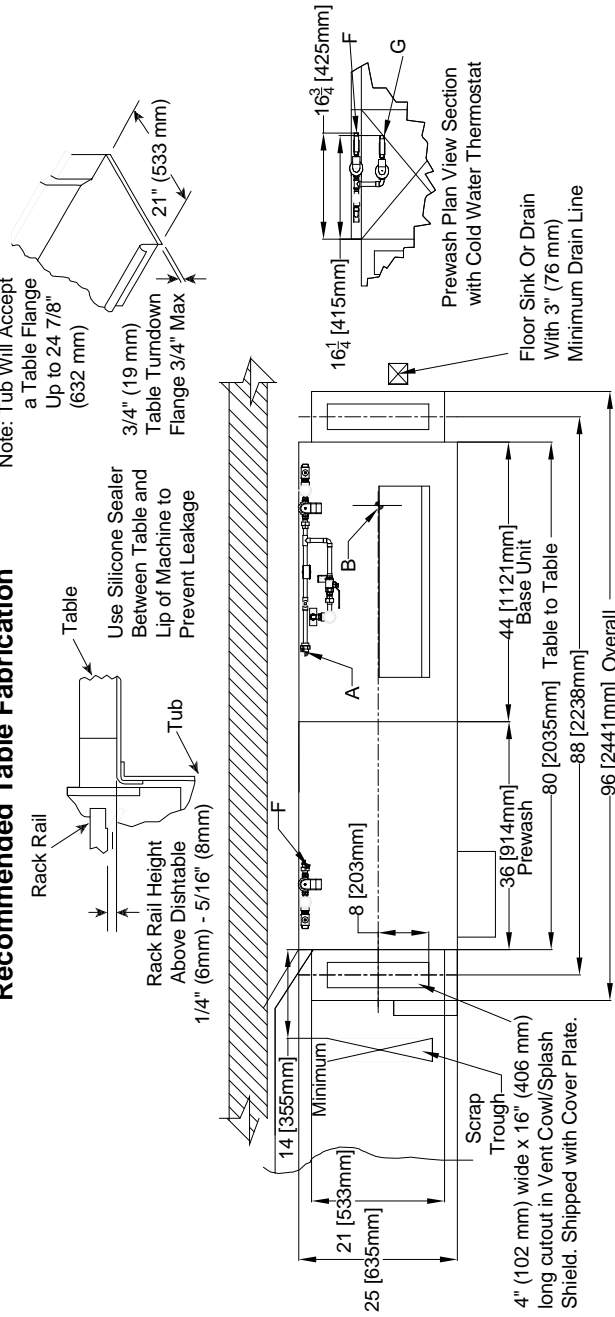

Left to Right

- Legend
- A - Machine water inlet 3/4" NPT, 180°F Hi-temp, 140°F Low-temp minimum
 - B - Electrical connection
 - C - Drain connection 1-1/2" NPT
 - D - Vent collar - Optional
 - E - Vent cowl standard
 - F - Prewash water inlet 3/4" NPT 110°F-140°F
 - G - Cold water thermostat plumbing connection 3/4" NPT - Optional

Note: All vertical dimensions are +/- 1/2" from floor due to adjustable bullet feet.

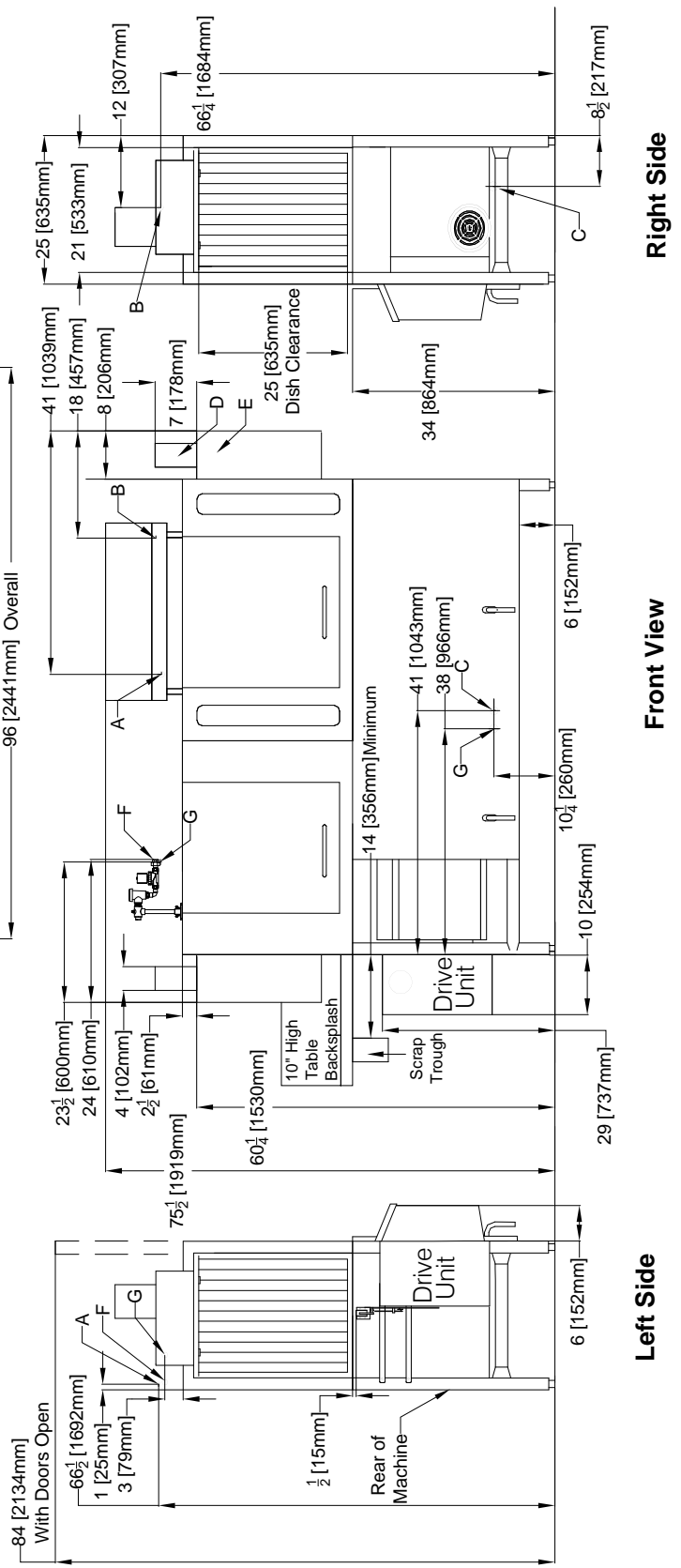

SECTION 1: SPECIFICATION INFORMATION

AJ-80T ELECTRIC - RIGHT TO LEFT

Right to Left

Legend

- A - Machine water inlet 3/4" NPT, 180°F Hi-temp, 140°F Low-temp minimum
- B - Electrical connection
- C - Drain connection 1-1/2" NPT
- D - Vent collar - Optional
- E - Vent cowl standard
- F - Prewash water inlet 3/4" NPT 110°F-140°F
- G - Cold water thermostat plumbing connection 3/4" NPT - Optional

Note: All vertical dimensions are +/- 1/2" from floor due to adjustable bullet feet.

4" (102 mm) wide x 16" (406 mm) long cutout in Vent Cowl/Splash Shield. Shipped with Cover Plate.

Recommended Table Fabrication

Note: Tub Will Accept a Table Flange Up to 24 7/8" (632 mm)

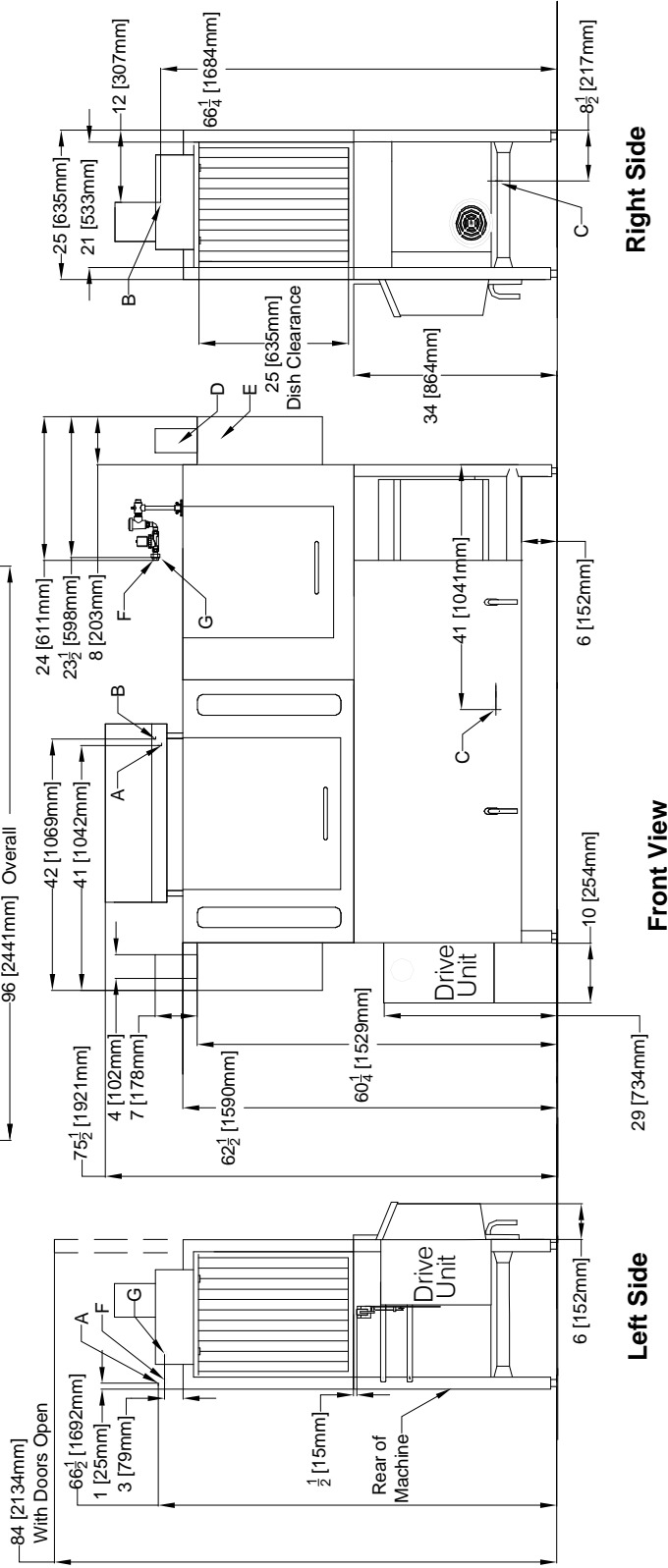
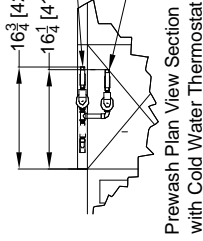
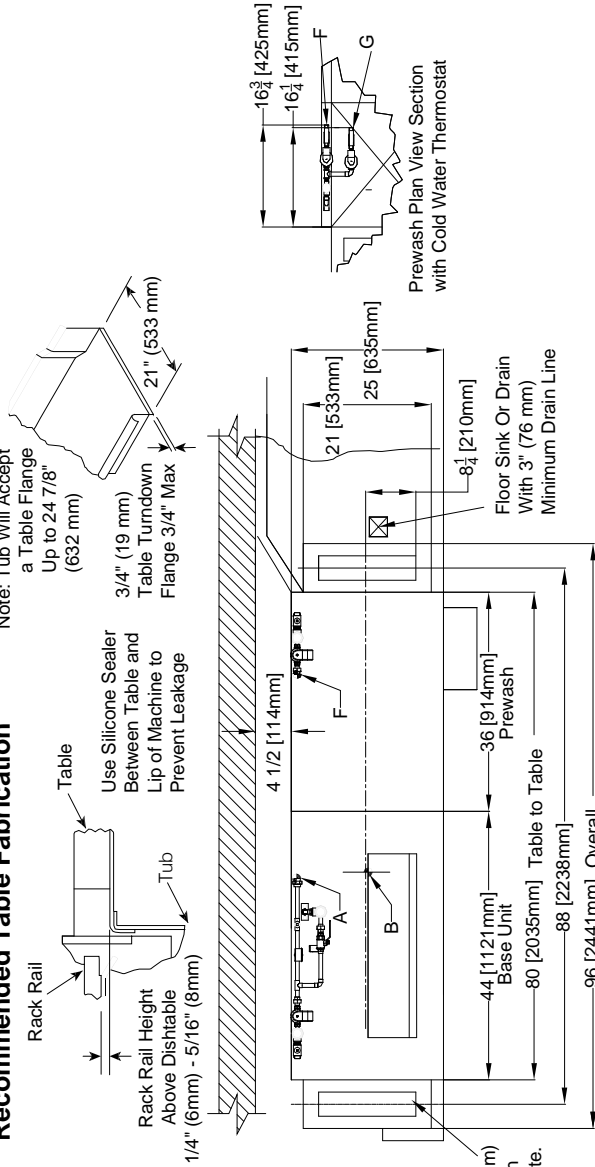

SECTION 1: SPECIFICATION INFORMATION

AJ-80T STEAM - LEFT TO RIGHT

Left to Right

- Legend**
- A - Machine water inlet 3/4" NPT 180°F Hi-temp, 140°F Low-temp minimum
 - B - Electrical connection
 - C - Drain connection 1-1/2" NPT
 - D - Vent collar - Optional
 - E - Vent cow standard
 - F - 3/4" NPT Steam connection
 - G - 3/4" NPT Condensate return
 - H - Steam electrical connection
 - J - 1" NPT Steam connection
 - K - 3/4" Condensate connection
 - L - 3/4" NPT Incoming 110°F water connection
 - M - 3/4" NPT 180°F water to dishmachine.
 - N - Prewash water inlet 3/4" NPT 110°F-140°F
 - O - Cold water thermostat plumbing connection 3/4" NPT - Optional

Note: All vertical dimensions are +/- 1/2" from floor due to adjustable bullet feet.

Recommended Table Fabrication

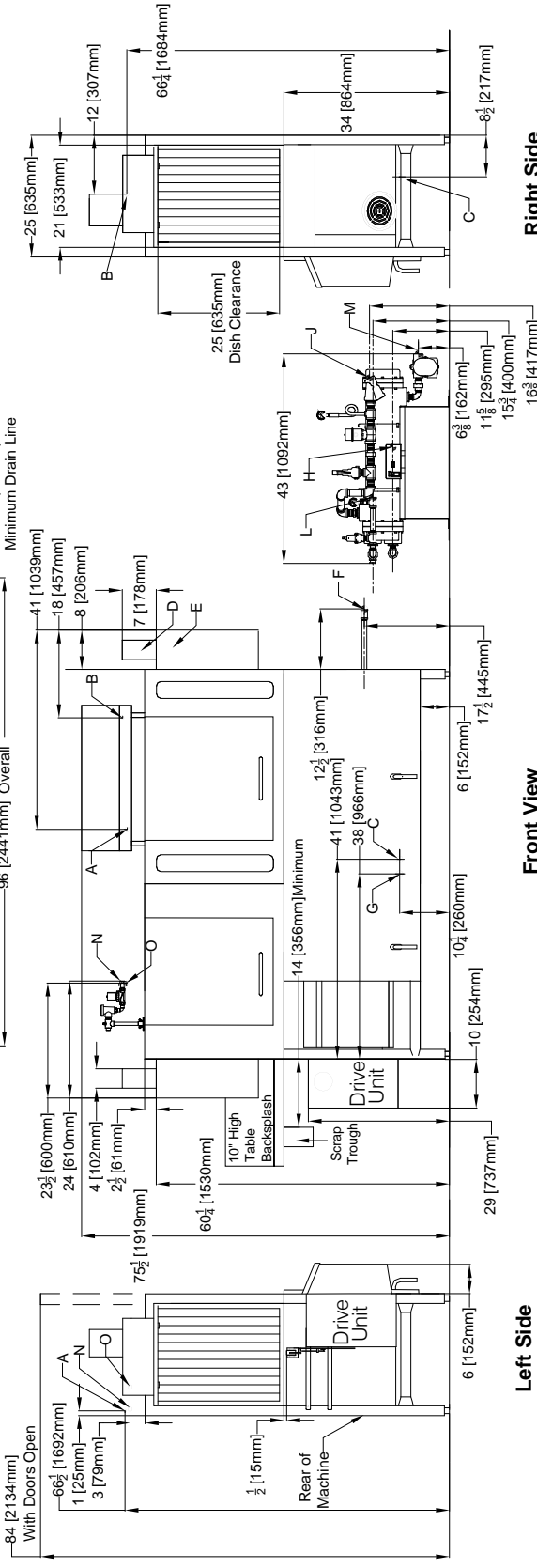
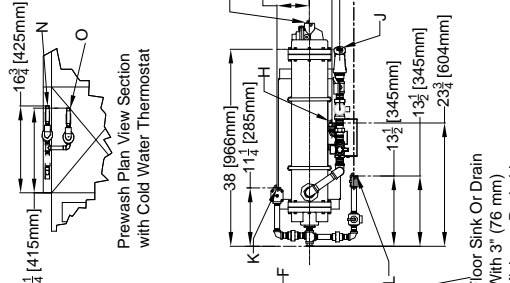
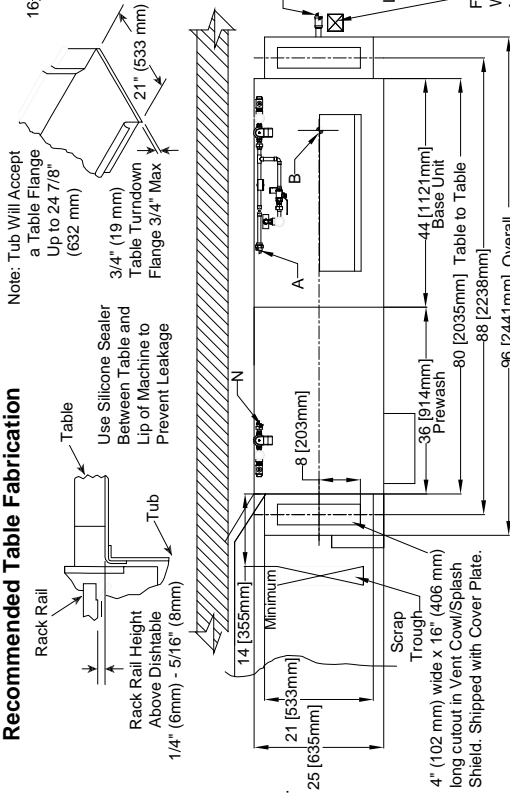

SECTION 1: SPECIFICATION INFORMATION

SIDE LOADER (LEFT TO RIGHT) DIMENSIONS

NOTE: ALL DIMENSIONS ARE TYPICAL.

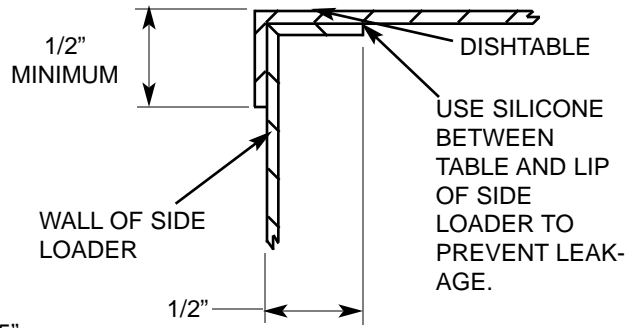

SECTION "A-A"

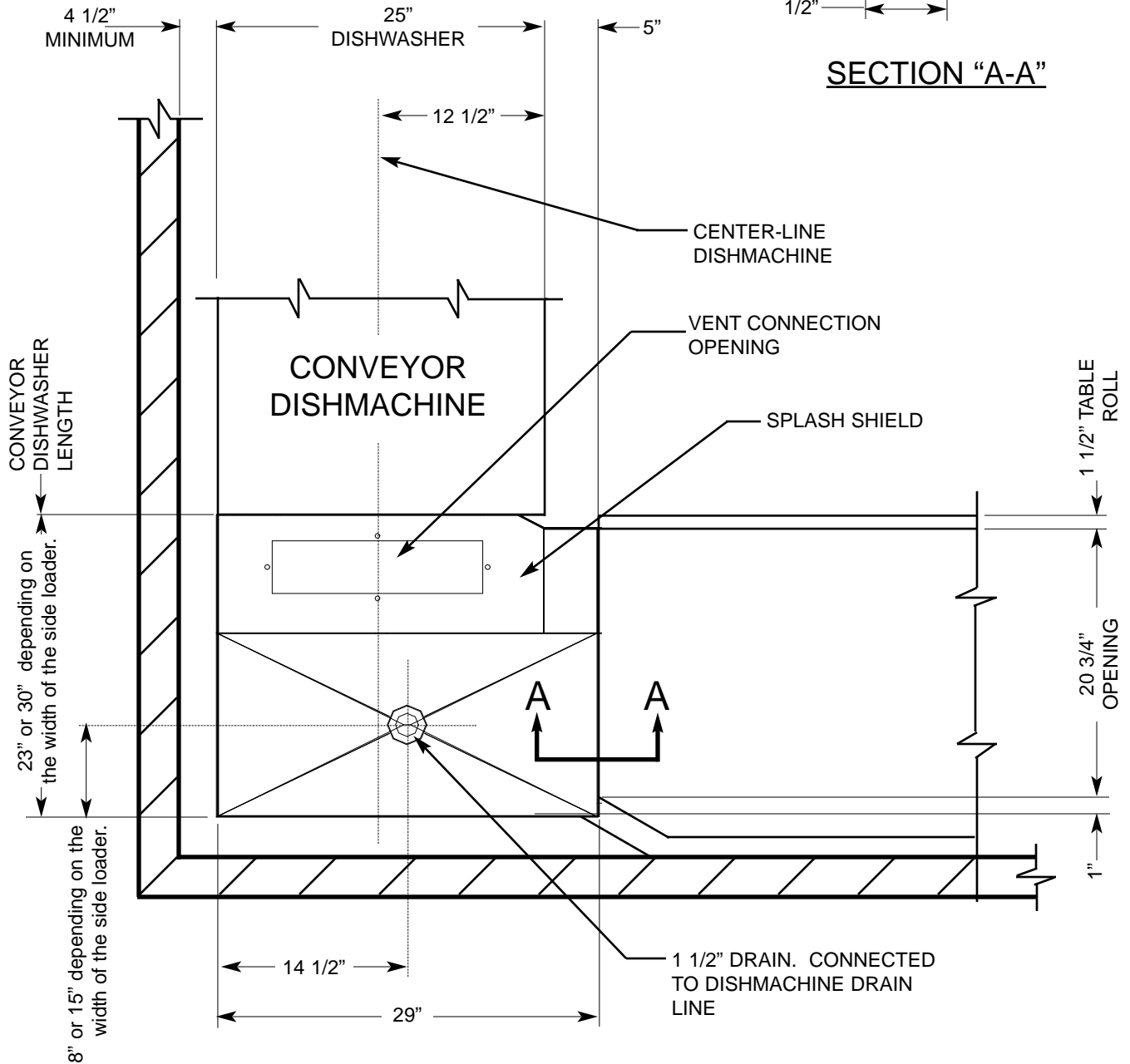

SECTION 1: SPECIFICATION INFORMATION

SIDE LOADER (RIGHT TO LEFT) DIMENSIONS

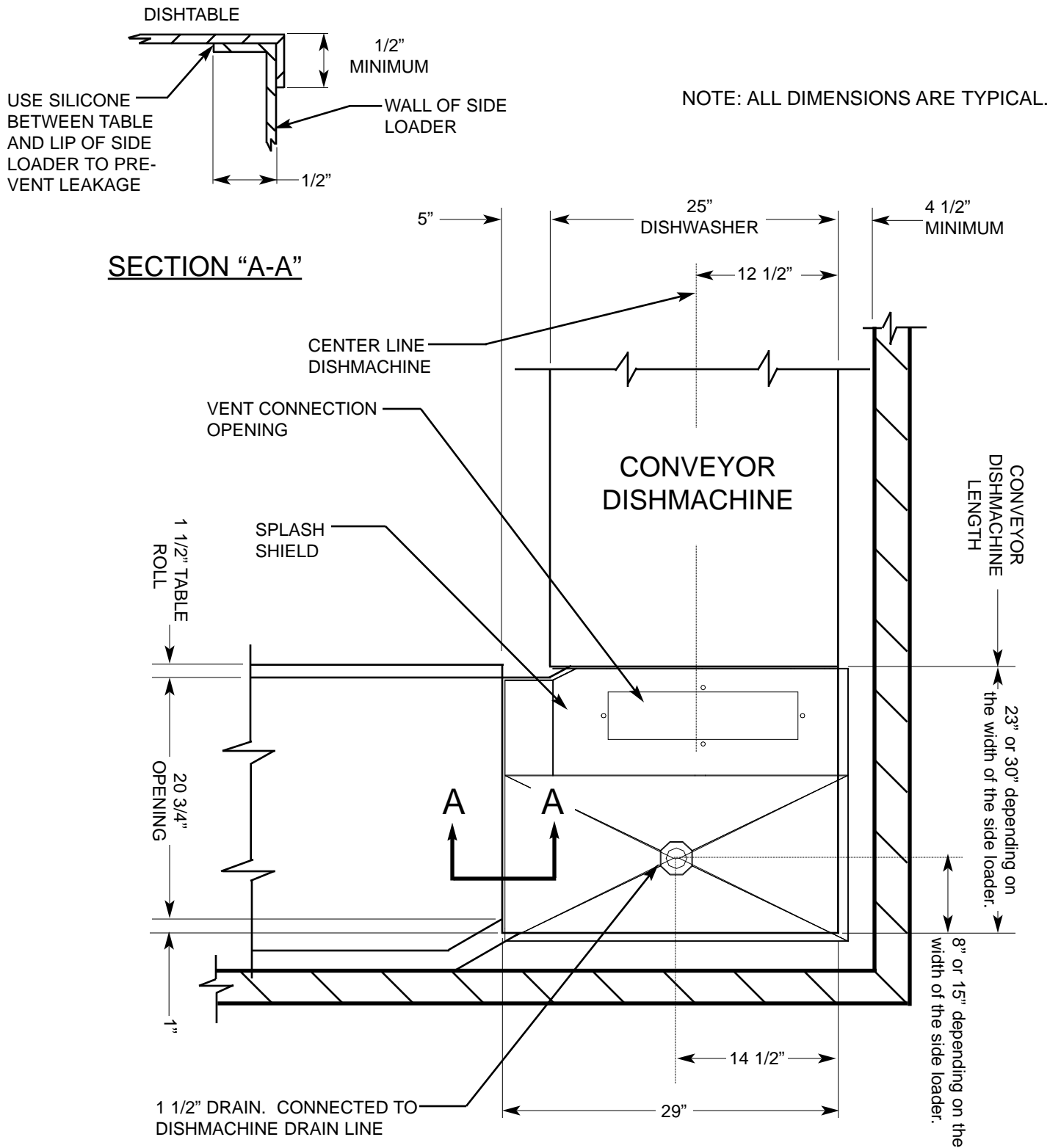

SECTION 1: SPECIFICATION INFORMATION

SIDE LOADER (INSTALLED) DIMENSIONS

23" SIDE LOADER DIMENSIONS

<u>MODEL</u>	<u>DIMENSIONS</u>
AJ-44T	75"
AJ-66T	97"
AJ-80T	111"

30" SIDE LOADER DIMENSIONS

<u>MODEL</u>	<u>DIMENSIONS</u>
AJ-44T	82"
AJ-66T	104"
AJ-80T	118"

NOTE: ALL DIMENSIONS ARE TYPICAL.

(Left to Right installation shown for reference.)

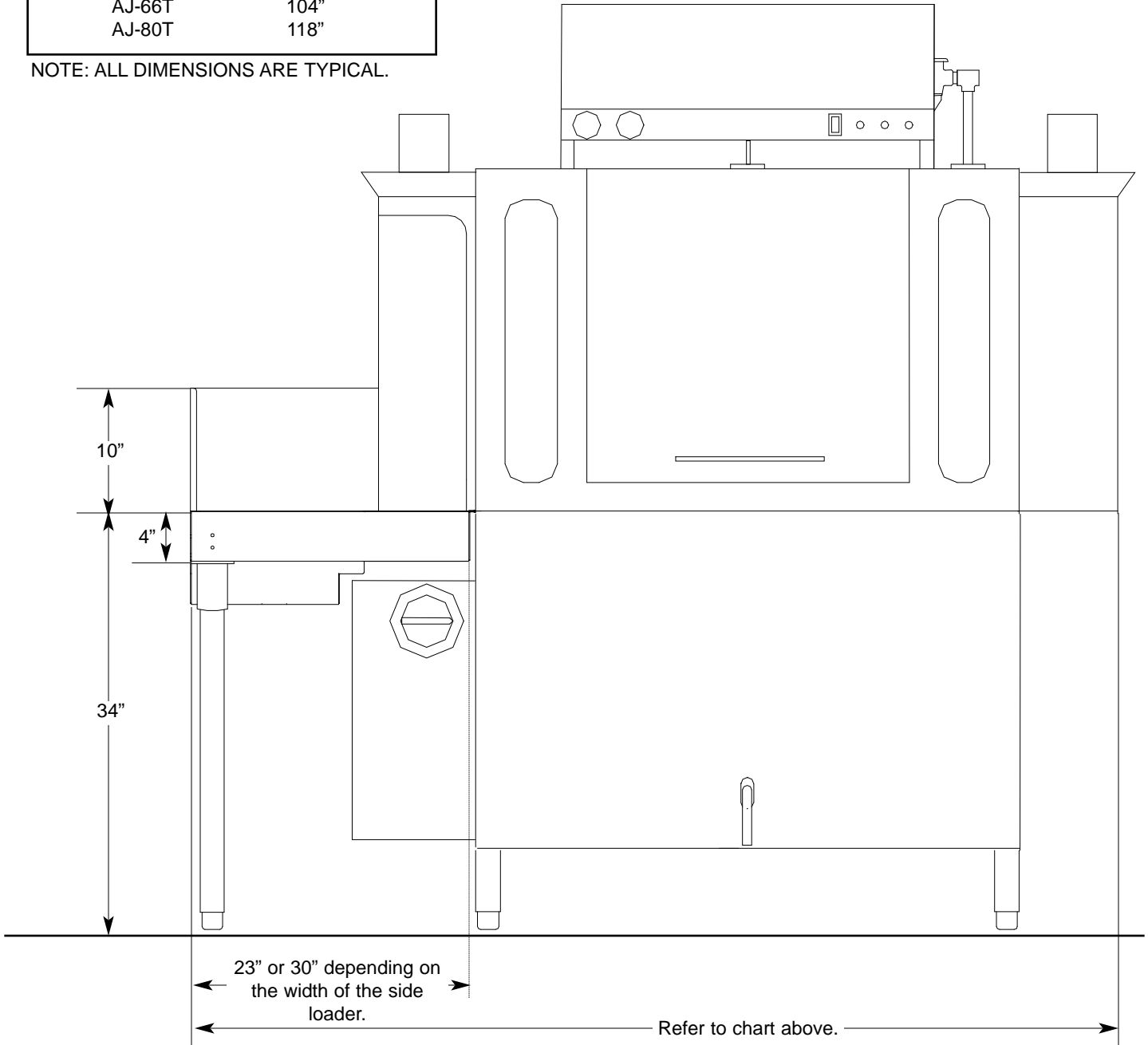

**SECTION 2:
INSTALLATION & OPERATION
INSTRUCTIONS**

SECTION 2: INSTALLATION/OPERATION INSTRUCTIONS

INSTALLATION INSTRUCTIONS

NOTE: THE INSTRUCTIONS PROVIDED HEREIN, UNLESS OTHERWISE SPECIFIED ARE FOR THE DISHMACHINES ONLY. THERE ARE SEPARATE DIRECTIONS FOR THE GAS BOOSTER.



VISUAL INSPECTION: Before installing the unit, check the container and machine for damage. A damaged container is an indicator that there may be some damage to the machine. If there is damage to both the container and machine, do not throw away the container. The dishmachine has been inspected and packed at the factory and is expected to arrive to you in new, undamaged condition. However, rough handling by carriers or others may result in damage to the unit while in transit. If such a situation occurs, do not return the unit to Jackson; instead, contact the carrier and ask them to send a representative to the site to inspect the damage to the unit and to complete an inspection report. You must contact the carrier within 48 hours of receiving the machine. Also, contact the dealer through which you purchased the unit.

UNPACKING THE DISHMACHINE: The machine should be unboxed and removed from shipping pallet prior to being installed. Open the front door and remove all of the packing materials. Once unpacked, ensure that there are no missing parts from the machine. This may not be obvious at first. If it is discovered that an item is missing, contact Jackson immediately.

LEVEL THE DISHMACHINE: The dishmachine is designed to operate while being level. This is important to prevent any damage to the machine during operation and to ensure the best results when washing ware. The unit comes with adjustable bullet feet, which can be turned using a pair of channel locks or by hand if the unit can be raised safely. Ensure that the unit is level from side to side and from front to back before making any connections. You will be able to adjust the overall height of the unit by turning the bullet feet from between 75-1/2" to 76-1/2".

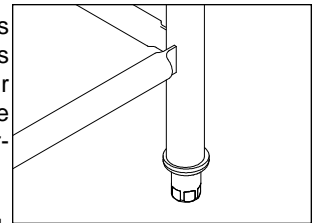

PLUMBING THE DISHMACHINE: All plumbing connections must comply with all applicable local, state, and national plumbing codes. The plumber is responsible for ensuring that the incoming water line is thoroughly flushed prior to connecting it to any component of the dishmachine. It is necessary to remove all foreign debris from the water line that may potentially get trapped in the valves or cause an obstruction. Any valves that are fouled as a result of foreign matter left in the water line, and any expenses resulting from this fouling, are not the responsibility of the manufacturer.

Water hardness should be a maximum of 6 grains per gallon. Harder water should be treated prior to using the machine. Iron in the water supply can cause staining. A filter designed to remove iron from the supply water is highly recommended for supplies in excess of 0.1 ppm (parts per million).

CONNECTING THE DRAIN LINE: The drain for the models covered in this manual are gravity discharge drains. All piping from the machine to the drain must be a minimum 1 1/2" NPT and shall not be reduced. There must also be an air gap between the machine drain line and the floor sink or drain. If a grease trap is required by code, it should have a flow capacity of 30 gallons per minute.

WATER SUPPLY CONNECTION: Ensure that you have read the section entitled "PLUMBING THE DISHMACHINE" above before proceeding. The supply water temperature must meet the minimum requirements listed on the machine data plate. Install the water supply line (1/2" pipe size minimum) to the dishmachine line strainer. It is recommended that a water shut-off valve be installed in the water line between the main supply and the machine to allow access for service. The water supply line is to be capable of 25 PSI "flow" pressure at the recommended temperature indicated on the data plate.

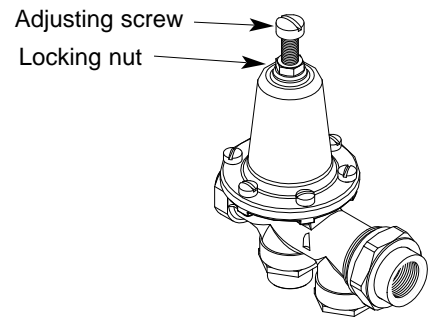

Incoming Plumbing Connection

If the water level is too low or too high, check the incoming water pressure. It should be 20 ± 5 PSI. Too high of pressure results in too much water; too low of pressure results in too little water. To adjust the regulator, loosen the nut at the top, this will allow you to screw or unscrew the adjustment. With a screwdriver, turn the adjuster clockwise to increase pressure or counter clockwise to decrease it.

Do not confuse static pressure with flow pressure. Static pressure is the line pressure in a "no flow" condition (all valves and services are closed). Flow pressure is the pressure in the fill line when the fill valve is opened during the cycle.

It is also recommended that a shock absorber (not supplied) be installed in the incoming water line. This prevents line hammer (hydraulic shock), induced by the solenoid valve as it operates, from causing damage to the equipment.

SECTION 2: INSTALLATION/OPERATION INSTRUCTIONS

INSTALLATION INSTRUCTIONS (CONTINUED)

STEAM LINE CONNECTIONS: Some machines covered in this manual are designed to use low pressure steam as a source of heat for wash tank water. The machines come with lines by which outside source steam needs to be connected. Connect all incoming steam lines in accordance with the steam booster manufacturer's instructions. Ensure that all applicable codes and regulations are adhered to. See machine data plate for information concerning steam flow pressure.

GAS CONNECTIONS: Some machines covered in this manual are designed to use gas as an outside source of heat for wash tank water. The machines come with connections by which an outside source needs to be connected. Connect all incoming gas lines in accordance with the gas booster manufacturer's instructions. Ensure that all applicable codes and regulations are adhered to.

PLUMBING CHECK: Slowly turn on the water supply to the machine after the incoming fill line and the drain line have been installed. Check for any leaks and repair as required. All leaks must be repaired prior to placing the machine in operation.

ELECTRICAL POWER CONNECTION: Electrical and grounding connections must comply with the applicable portions of the National Electrical Code ANSI/NFPA 70 (latest edition) and/or other electrical codes.

Disconnect electrical power supply and place a tag at the disconnect switch to indicate that you are working on the circuit.

The dishmachine data plate is located on the right side and to the front of the machine. Refer to the data plate for machine operating requirements, machine voltage, total amperage load and serial number.

To install the incoming power lines, open the control box. Install conduit into the pre-punched holes in the back of the control box. Route power wires and connect to power block and grounding lug. Install the service wires (L1, L2, and L3 (3 phase only)) to the appropriate terminals as they are marked on the terminal block. Install the grounding wire into the lug provided. Tighten the connections. It is recommended that "DE-OX" or another similar anti-oxidation agent be used on all power connections.

VOLTAGE CHECK: Ensure that the power switch is in the OFF position and apply power to the dishmachine. Check the incoming power at the terminal block and ensure it corresponds to the voltage listed on the data plate. If not, contact a qualified service agency to examine the problem. Do not run the dishmachine if the voltage is too high or too low. Shut off the service breaker and mark it as being for the dishmachine. Advise all proper personnel of any problems and of the location of the service breaker. Replace the control box cover and tighten down the screws.

VENTILATION OF DISHMACHINE: The dishmachine should be located with provisions for venting into an adequate exhaust hood or ventilation system. This is essential to permit efficient removal of the condensation exhaust. Ensure that the exhaust system is acceptable in accordance with all applicable codes and standards.

NOTE: Any damage that is caused by steam or moisture due to improper ventilation is NOT covered under the warranty.

This units covered in this manual have the following exhaust requirements:

Load End:	200 CFM
Unload End:	400 CFM

The exhaust system must be sized to handle this volume for the dishmachine to operate as it was designed to.

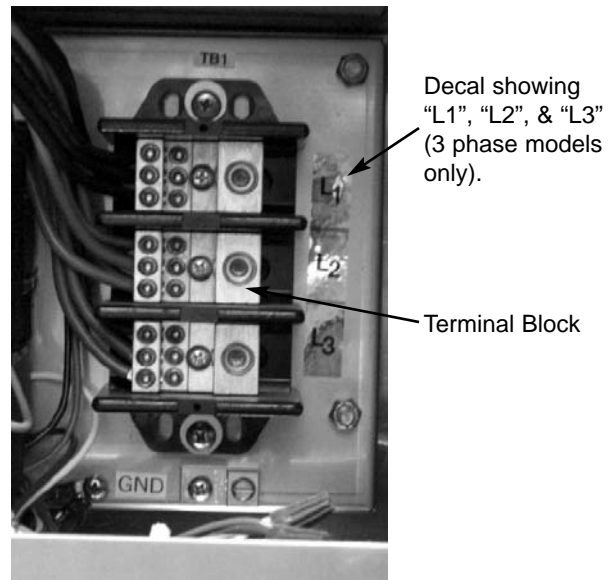

Incoming Power Connection

SECTION 2: INSTALLATION/OPERATION INSTRUCTIONS

INSTALLATION INSTRUCTIONS (CONTINUED)

ELECTRIC HEAT: The thermostats for the machines covered in this manual are factory set. They should not be adjusted except by an authorized service agent.

CHEMICAL FEEDER EQUIPMENT: Detergent may be introduced into the unit through the removal of the bulkhead plug in the rear of the tub and replacing it with the third party detergent injection fitting. Remove the bulkhead plug in the side of the tub to install the detergent concentration probe.

For more information concerning detergent concerns, please refer to the page entitled "Detergent Control".

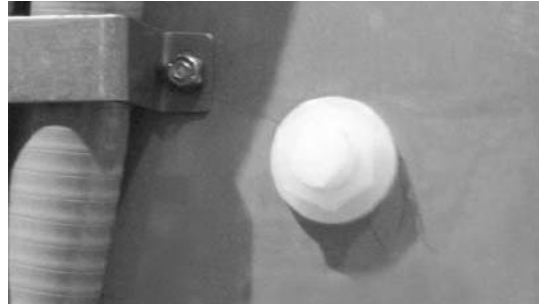

Detergent Connection Point
(Machine rear view)

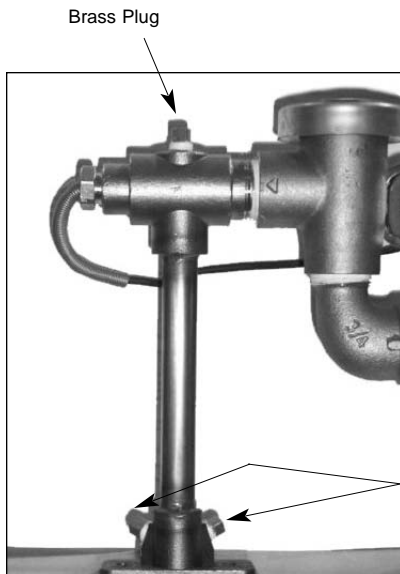

The 1/8" brass plugs on the incoming plumbing rinse injector may be removed to install sanitizer and rinse aid injection fittings.

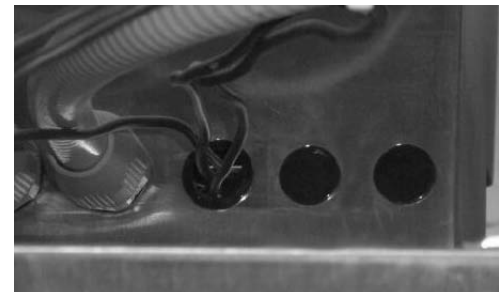

Back of Control Box

All wires for the chemical injectors should be routed through one of the extra openings in the back of the control box.

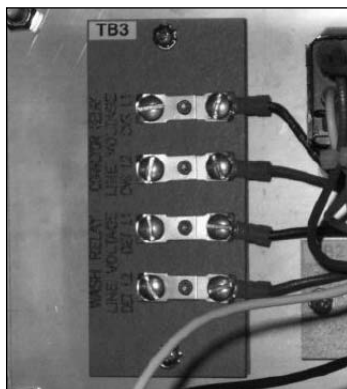

Aid Connection Points

Terminals in the control box marked "CVS" provide a constant voltage signal whenever the drive motor is operating.

Terminals in the control box marked "DET" provide a voltage signal whenever the wash motor is operating.

SECTION 2: INSTALLATION/OPERATION INSTRUCTIONS

CURTAIN INSTALLATION DIAGRAMS

Please refer to the chart for placement of the curtains.

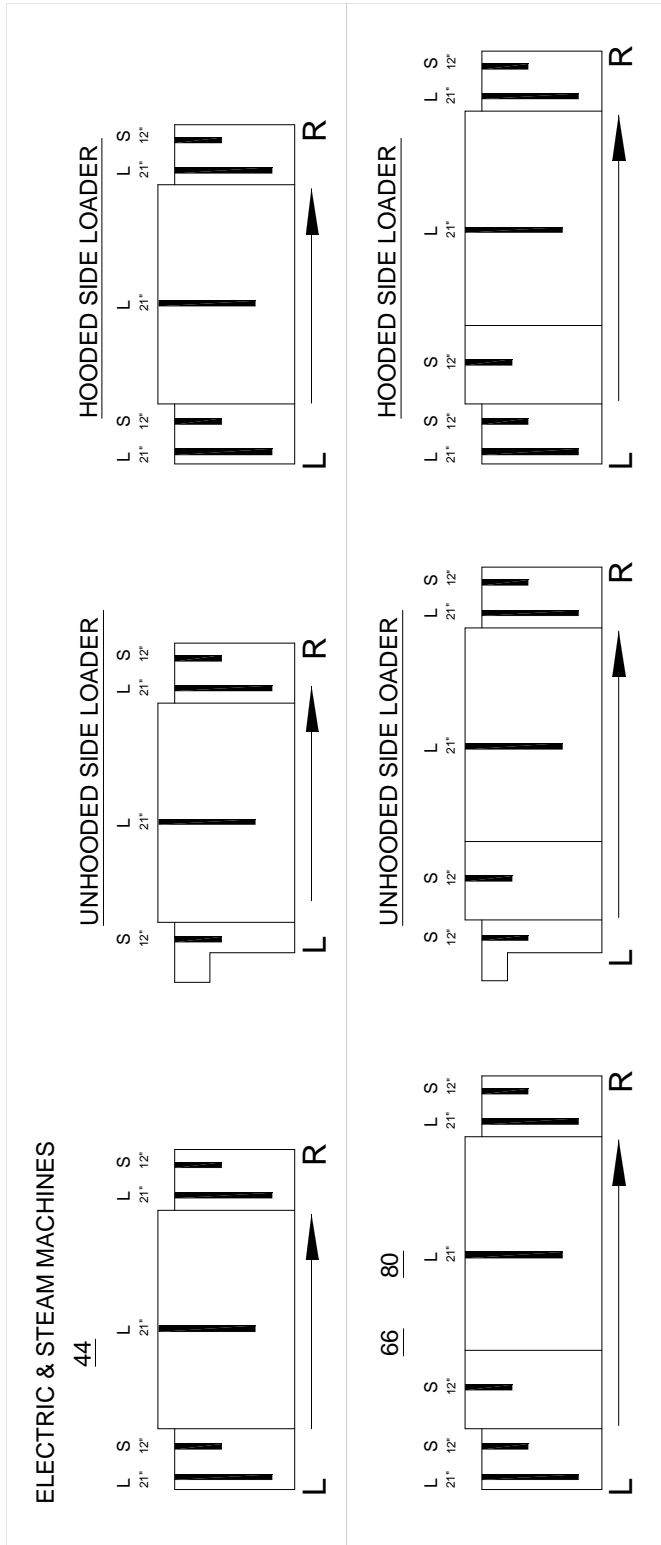

SECTION 2: INSTALLATION/OPERATION INSTRUCTIONS

DELIMING OPERATIONS

DELIMING OPERATIONS: In order to maintain the dishmachine at its optimum performance level, it will be required to remove lime and corrosion deposits on a frequent basis. A delimiting solution should be available from your detergent supplier. Read and follow all instructions on the label of the delimiting solution.

To proceed with the delimiting operation, fill the dishmachine and add the correct amount of delimiting solution as recommended by the delimiting solution manufacturer. The water capacity of the various tanks of the dishmachine can be verified on the specification sheet(s) of this manual.

Perform the following operations to delimit the dishmachine:

1. Turn the NORMAL/DELIME switch on the back of the control box to the DELIME position.
2. Disconnect or turn off all chemical feeder pumps.
3. Close all doors (after adding the delimiting solution).
4. Run the machine for the recommended period of time.
5. Turn the unit off and open the doors.
6. Wait five minutes, then inspect the inside of the machine. If the machine is not delimited, run another time cycle as per the delimiting solution's instructions.
7. When clean, drain and re-fill the machine.
8. Run in MANUAL for 10 minutes to remove residual delimiting solution.
9. Drain and re-fill the machine.

This equipment is not recommend for use with deionized water or other aggressive fluids. Use of deionized water or other aggressive fluids will result in corrosion and failure of materials and components. Use of deionized water or other aggressive fluids will void the manufacturer's warranty.

SECTION 2: INSTALLATION/OPERATION INSTRUCTIONS

SIDE LOADER INSTALLATION & OPERATION INSTRUCTIONS

This accessory assists in the delivery of a full dish rack from the break down (scrapping) table to the dishmachine. It will convert the direction of travel 90°. Since the Side Loader is shipped mounted on the conveyor dishwasher there is no additional installation required for this option. As it is operated mechanically by the dishwasher it does not require any plumbing or electrical connections.

This Side Loader does not require or add any additional electrical or mechanical devices to the unit which could create operational or maintenance problems. As designed the drive mechanism is powered by the conveyor drive motor on the dishmachine. An extension on the pawl bar provides the drive to push the racks into the unit.

PREPARATION: Before proceeding with the start-up of the unit, verify that the Side Loader pan strainer is installed.

WARE PREPARATION: Proper preparation of ware will help ensure good results and less re-washes. If not done properly, ware may not come out clean and the efficiency of the dishmachine will be reduced. It is important to remember that a dishmachine is not a garbage disposal and that simply throwing unscrapped dishes into the machine simply defeats the purpose altogether of washing the ware. Scraps should be removed from ware prior to being loaded into a rack. Pre-rinsing and pre-soaking are good ideas, especially for silverware and casserole dishes. Place cups and glasses upside down in racks so that they do not hold water during the cycle. The dishmachine is meant not only to clean, but to sanitize as well, to destroy all of the bacteria that could be harmful to human beings. In order to do this, ware must be properly prepared prior to being placed in the machine.

WASHING A RACK OF WARE: Once a rack is fully loaded it should be positioned against the front of the dish table. The rack should then be moved into the Side Loader until it activates the actuator switch. Once the machine is started, it should pull the rack through the machine and push it out the unload end. Once a rack has started through, you may put another rack in.

OPERATIONAL INSPECTION: Based upon usage, the pan strainer may become clogged with soil and debris as the workday progresses. Operators should regularly inspect the pan strainer to ensure it has not become clogged. If the strainer does become clogged, it will reduce the washing capability of the machine. Instruct operators to clean out the pan strainer at regular intervals or as required by work load.

SHUTDOWN AND CLEANING: At the end of the workday, remove the pan strainer and clean as required. Wipe out the inside of the Side Loader and then reinsert the strainer.

SECTION 2: INSTALLATION/OPERATION INSTRUCTIONS

DISHMACHINE OPERATING INSTRUCTIONS

PREPARATION: Before proceeding with the start-up of the unit, verify the following:

1. Close door(s) on dishmachine.
2. Close the drain valve(s).

POWER UP (ELECTRICALLY-HEATED MODELS): To energize the unit, turn on the power at the service breaker. The voltage should have been previously verified as being correct. If not, the voltage will have to be verified.

POWER UP (GAS-HEATED MODELS): To energize the unit, turn on the power at the service breaker. The voltage should have been previously verified as being correct. If not, the voltage will have to be verified. Ensure that the gas service is connected and that gas is flowing to the machine. Without gas, the water will not reach the required minimum temperatures that the machine is designed to operate at.

POWER UP (STEAM-HEATED MODELS): To energize the unit, turn on the power at the service breaker. The voltage should have been previously verified as being correct. If not, the voltage will have to be verified. Ensure that the steam service is connected and that steam is flowing to the machine. Without steam, the water will not reach the required minimum temperatures that the machine is designed to operate at.

FILLING THE WASH TUB: Ensure that the delime switch is in the NORMAL position, and place the power switch into the ON position. The machine should fill automatically and shut off when the appropriate level is reached (just below the pan strainer). The wash tub must be completely filled before operating the wash pump to prevent damage to the component. Once the wash tub is filled, the unit is ready for operation.



Machines equipped with prewash sections should not be run without water in those sections. This can cause damage to components.

WARE PREPARATION: Proper preparation of ware will help ensure good results and less re-washes. If not done properly, ware may not come out clean and the efficiency of the dishmachine will be reduced. It is important to remember that a dishmachine is not a garbage disposal and that simply throwing unscrapped dishes into the machine simply defeats the purpose altogether of washing the ware. Scraps should be removed from ware prior to being loaded into a rack. Pre-rinsing and pre-soaking are good ideas, especially for silverware and casserole dishes. Place cups and glasses upside down in racks so that they do not hold water during the cycle. The dishmachine is meant not only to clean, but to sanitize as well, to destroy all of the bacteria that could be harmful to human beings. In order to do this, ware must be properly prepared prior to being placed in the machine.

DAILY MACHINE PREPARATION: Refer to the section entitled "PREPARATION" at the top of this page and follow the instructions there. Afterwards, check that all of the chemical levels are correct and/or that there is plenty of detergent available for the expected workload.

WASHING A RACK OF WARE: To wash a rack, simply slide a rack of soiled ware into the load end of the machine. Once the machine is started, it should pull the rack through the machine and push it out the unload end. Once a rack has started through, you may put another rack in.

OPERATIONAL INSPECTION: Based upon usage, the pan strainers may become clogged with soil and debris as the work-day progresses. Operators should regularly inspect the pan strainers to ensure they have not become clogged. If the strainers do, they will reduce the washing capability of the machine. Instruct operators to clean out the pan strainers at regular intervals or as required by work load.

NOTE: On units equipped with prewash sections (AJ-66 & AJ-80), operators should also take the time to inspect the prewash section strainers and clean them as required by workload.

SECTION 2: INSTALLATION/OPERATION INSTRUCTIONS

DISHMACHINE OPERATION INSTRUCTIONS (CONTINUED)

SHUTDOWN AND CLEANING (ELECTRICALLY-HEATED MODELS): At the end of the workday, place the power switch in the OFF position and open the door(s). Open the drain valves and allow the machine to drain completely. Remove the pawl bar assembly (clean as required). Remove the pan strainers and, if equipped, the prewash strainers, run off sheets and scrap basket strainer. Remove the wash and, if equipped, the prewash arms and verify that the nozzles and arms are free from obstructions. Flush the arms with fresh water. Remove the pump suction strainers and clean out as required. Remove the rinse tray assembly and clean. Remove the curtains and scrub with a mild detergent and warm water. Wipe out the inside of the unit and then reassemble with the components previously removed.

SHUTDOWN AND CLEANING (GAS-HEATED MODELS): At the end of the work day, shut down the gas booster in accordance with manufacturer's instructions. Place the power switch in the OFF position, secure the flow to the machine and open the door(s). Open the drain valves and allow the machine to drain completely. Remove the pawl bar assembly (clean as required). Remove the pan strainers and, if equipped, the prewash strainers, run off sheets and scrap basket strainer. Remove the wash and, if equipped, the prewash arms and verify that the nozzles and arms are free from obstructions. Flush the arms with fresh water. Remove the pump suction strainers and clean out as required. Remove the rinse tray assembly and clean. Remove the curtains and scrub with a mild detergent and warm water. Wipe out the inside of the unit and then reassemble with the components previously removed.

SHUTDOWN AND CLEANING (STEAM-HEATED MODELS): At the end of the workday, place the power switch in the OFF position, secure the flow of steam to the machine and open the door(s). Open the drain valves and allow the machine to drain completely. Remove the pawl bar assembly (clean as required). Remove the pan strainers and, if equipped, the prewash strainers, run off sheets and scrap basket strainer. Remove the wash and, if equipped, the prewash arms and verify that the nozzles and arms are free from obstructions. Flush the arms with fresh water. Remove the pump suction strainers and clean out as required. Remove the rinse tray assembly and clean. Remove the curtains and scrub with a mild detergent and warm water. Wipe out the inside of the unit and then reassemble with the components previously removed.

SECTION 2: INSTALLATION/OPERATION INSTRUCTIONS

DETERGENT CONTROL

Detergent usage and water hardness are two factors that contribute greatly to how efficiently your dishmachine will operate. Using detergent in the proper amount can become, in time, a source of substantial savings. A qualified water treatment specialist can tell you what is needed for maximum efficiency from your detergent, but you should still know some basics so you'll understand what they are talking about.

First, you must understand that hard water greatly effects the performance of the dishmachine. Water hardness is the amount of dissolved calcium and magnesium in the water supply. The more dissolved solids in the water, the greater the water hardness. Hard water works against detergent, thereby causing the amount of detergent required for washing to increase. As you use more detergent, your costs for operating the dishmachine will increase and the results will decrease. The solids in hard water also may build-up as a scale on wash and rinse heaters, decreasing their ability to heat water. Water temperature is important in removing soil and sanitizing dishes. If the water cannot get hot enough, your results may not be satisfactory. This is why Jackson recommends that if you have installed the machine in an area with hard water, that you also install some type of water treatment equipment to help remove the dissolved solids from the water before it gets to the dishmachine.

Second, hard water may have you adding drying agents to your operating cycle to prevent spotting, when the real problem is deposited solids on your ware. As the water evaporates off of the ware, the solids will be left behind to form the spotting and no amount of drying agent will prevent this. Again, using treated water will undoubtedly reduce the occurrences of this problem.

Third, treated water may not be suitable for use in other areas of your operation. For instance, coffee made with soft water may have an acid or bitter flavor. It may only be feasible to install a small treatment unit for the water going into the dishmachine itself. Discuss this option with your qualified water treatment specialist.

Even after the water hardness problems have been solved, there still must be proper training of dishmachine operators in how much detergent is to be used per cycle. Talk with your water treatment specialist and detergent vendor and come up with a complete training program for operators. Using too much detergent has as detrimental effects as using too little. The proper amount of detergent must be used for job. It is important to remember that certain menu items may require extra detergent by their nature and personnel need to be made aware of this. Experience in using the dishmachine under a variety of conditions, along with good training in the operation of the machine, can go a long way in ensuring your dishmachine operates as efficiently as possible.

Certain dishmachine models require that chemicals be provided for proper operation and sanitization. Some models even require the installation of third-party chemical feeders to introduce those chemicals to the machine. Jackson does not recommend or endorse any brand name of chemicals or chemical dispensing equipment. Contact your local chemical distributor for questions concerning these subjects.

Some dishmachines come equipped with integral solid detergent dispensers. These dispensers are designed to accommodate detergents in a certain sized container. If you have such a unit, remember to explain this to your chemical distributor upon first contacting them.

As explained before, water temperature is an important factor in ensuring that your dishmachine functions properly. The data plate located on each unit details what the minimum temperatures must be for either the incoming water supply, the wash tank and the rinse tank, depending on what model of dishmachine you have installed. These temperatures may also be followed by temperatures that Jackson recommends to ensure the highest performance from you dishmachine. However, if the minimum requirements are not met, the chances are your dishes will not be clean or sanitized. Remember, a dish can look clean, but it may not be sanitized. Instruct your dishmachine operators to observe the required temperatures and to report when they fall below the minimum allowed. A loss of temperature can indicate a much larger problem such as a failed heater or it could also indicate that the hot water heater for your operation is not up to capacity and a larger one may need to be installed.

There are several factors to consider when installing your dishmachine to ensure that you get the best possible results from it and that it operates at peak efficiency for many years. Discuss your concerns with your local chemical distributor and water treatment specialist before there is a problem.

SECTION 2: INSTALLATION/OPERATION INSTRUCTIONS

STRIKER PLATE LIMIT SWITCH INSTALLATION INSTRUCTIONS

Installation Instructions:

1. Wiring: The switch is wired common and normally open because of the hinge design. By interrupting the line in series with the door switches, the dishmachine ceases to operate. Refer to the machine schematic for details on how to wire the switch.

2. Parts of the table switch are mounted in the dishtable, at the end of the table and under the table. See the drawing(s) for the relationship of the switch to the table.

3. Move the limit switch as far down on the two slots as possible and see that the limit switch is straight on the base plate. This might require adjustment of the nut on the connector for the limit switch.

4. Then adjust the inside and the outside connector nuts for the connector box so that it lines up even with the limit switch and the base plate.

5. Tighten down the nuts for the seal so that they are tight.

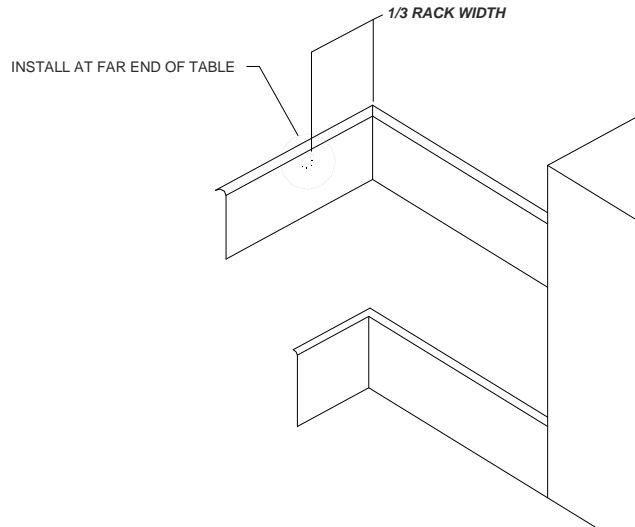

6. If you have any difficulty you might have to adjust the connectors to the seal, screwing in or screwing out until the installation is straight on the table and the limit switch is actuated correctly by the rack.

TABLE LIMIT SWITCH THROUGH ROD HOLES

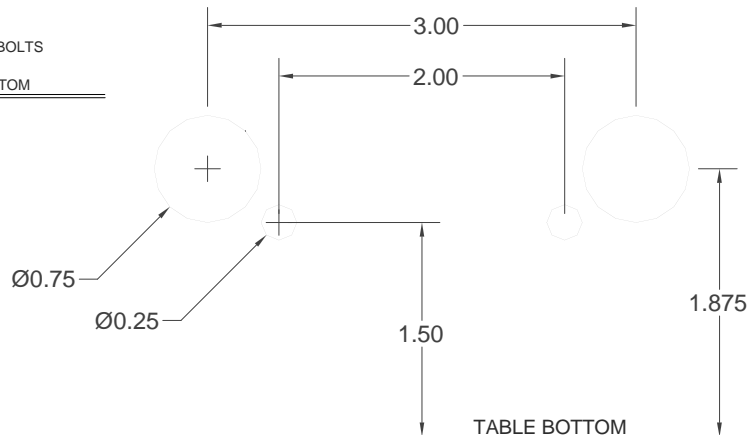
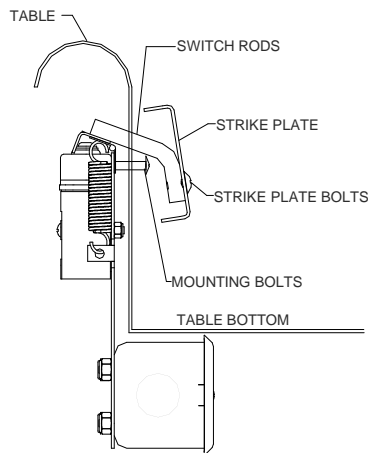

Unless noted, all dimensions are in inches.

SECTION 3: PREVENTATIVE MAINTENANCE

SECTION 3: PREVENTATIVE MAINTENANCE

PREVENTATIVE MAINTENANCE

The dishmachines covered in this manual are designed to operate with a minimum of interaction with the operator. However, this does not mean that some items will not wear out in time. Jackson highly recommends that any maintenance and repairs not specifically discussed in this manual should be performed by **QUALIFIED SERVICE PERSONNEL ONLY**. Performing maintenance on your dishmachine may void your warranty if it is still in effect, so if you have a question or concern, do not hesitate to contact Jackson.

There are many things that operators can do to prevent catastrophic damage to the dishmachine. One of the major causes of component failure has to do with prescraping procedures. A dishmachine is not a garbage disposal; any large pieces of material that are put into the machine shall remain in the machine until they are either broken up (after spreading out on your ware!) or physically removed. Strainers are installed to help catch debris, but they do no good if they are clogged. Have operators regularly inspect the pan strainers to ensure (1) that they are free of soil and debris and (2) they are laying flat in the tub.

When cleaning out strainers, do **NOT** beat them on waste cans. The strainers are made of metal and can be forgiving; but once severe damage is done, it is next to impossible for the strainer to work in the way it was designed to. Wipe out strainers with a rag and rinse under a faucet if necessary. For stubborn debris, a toothpick should be able to dislodge any obstructions from the perforations. Always ensure that strainers are placed back in the machine before operation and that they lay flat in the tub.

You may wish to also refer to the page entitled "Detergent Control" in order to learn more about how your water hardness will effect the performance of your machine. Hard water makes dishmachines work harder and decreases efficiency.

Again, it is important to remind operators that trying to perform corrective maintenance on the dishmachine could lead to larger problems or even cause harm to the operator. If a problem is discovered; secure the dishmachine using proper shut down procedures as listed in this manual and contact Jackson.

Some problems, however, may have nothing to do with the machine itself and no amount of preventative maintenance is going to help. A common problem has to do with temperatures being too low. Verify that the water temperatures coming to your dishmachine match the requirements listed on the machine data plate. There can be a variety of reasons why your water temperature could be too low and you should discuss it with Jackson to determine what can be done.

By following the operating and cleaning instructions in this manual, you should get the most efficient results from your machine. As a reminder, here are some steps to take to ensure that you are using the dishmachine the way it was designed to work:

1. Ensure that the water temperatures match those listed on the machine data plate.
2. Ensure that all strainers are in place before operating the machine.
3. Ensure that all wash and/or rinse arms are secure in the machine before operating.
4. Ensure that drains are closed/sealed before operating.
5. Remove as much soil from dishes by hand as possible before loading into racks.
6. Do not overfill racks.
7. Ensure that glasses are placed upside down in the rack.
8. Ensure that all chemicals being injected to machine have been verified as being at the correct concentrations.
9. Clean out the machine at the end of every workday as per the instructions in the manual.
10. Always contact Jackson whenever a serious problem arises.
11. Follow all safety procedures, whether listed in this manual or put forth by local, state or national codes/regulations.

SECTION 3: PREVENTATIVE MAINTENANCE

LUBRICATION CHART FOR DRIVE GEAR

Note: The maintenance procedures detailed here are manufacturer's instructions for the WINSMITH brand of gear reducer that is installed on the rack conveyors covered in this manual.

Ambient Temperature	-30 - 15°F	16 - 50°F	51 - 95°F	51 - 95°F	96 - 131°F	96 - 131°F
Final Stage Worm Speed ¹	up to 2000 FPM	up to 2000 FPM	up to 450 FPM	above 450 FPM	up to 450 FPM	above 450 FPM
ISO Viscosity Grade	220	460	680	460	680	460
AGMA Lubricant No.	5S	#7 Compounded	#8 Compounded	#7 Compounded	8S	7S
Mobil	SHC 630	600W Super Cylinder	Extra Hecla Super	600W Super Cylinder	SHC 636	SHC 634
American Lubricants	SHC-90W	AGMA #7 Gear Oil	AGMA #8 Gear Oil	AGMA #7 Gear Oil	N/A	N/A
Castrol	Tribol 800/220	Tribol 1105-7C	Tribol 1105-8C	Tribol 1105-7C	Tribol 800/680	Tribol 800/460
Chevron	Tegra 220	Cylinder Oil W460	Cylinder Oil W680	Cylinder Oil W460	Tegra 680	Tegra 460
Conoco	Syncon R & O 220	Inca Oil 460	Inca Oil 680	Inca Oil 460	N/A	Syncon R & O 460
Exxon (Esso)	Teresstic SHP220	Spartan EP 460	Spartan EP 680	Spartan EP 460	Teresstic SHP 680	Teresstic SHP 460
Fiske Brothers	SPO-MG	SPO-277	SPO-288	SPO-277	N/A	N/A
Shell	Omala RL 220	Valvata J 460	Valvata J 680	Valvata J 460	Omala RL 680	Omala RL 460
Texaco	Pinnacle 220	Vanguard 460	Vanguard 680	Vanguard 460	Pinnacle 680	Pinnacle 460

(1) The sliding velocity in feet per minute (FPM) for standard ratios is determined by multiplying the speed of the worm in RPM by the factor from the table below. For selecting proper lubricant, use the speed of the worm in the final stage (input RPM divided by the first stage ratio).

SECTION 3: PREVENTATIVE MAINTENANCE

DRIVE MOTOR GEAR REDUCER PREVENTATIVE MAINTENANCE

Note: The maintenance procedures detailed here are manufacturer's instructions for the WINSMITH brand of gear reducer that is installed on the rack conveyors covered in this manual.

Lubrication & Maintenance:

Factory filling - WINSMITH speed reducers are oil filled at the factory to the proper level for the standard mounting position that you will find it in on the unit. The oil level should be checked and adjusted (if necessary) prior to operation, using the oil level plug provided and while the unit is oriented in its operating position.

Ambient temperature - If the operating ambient temperature is other than 51 - 95°F, then refer to the lubrication chart and refill the unit with the correct grade based on actual ambient temperature and operating speed. See "Oil changing" below for additional information.

Oil changing - When changing the oil for any reason, it should be remembered that oils of various types may not be compatible. Therefore, when changing to a different oil, it is recommended that the housing be completely drained and thoroughly flushed with a light flushing oil prior to refilling with the appropriate lubricant. The oil level should be rechecked after a short period of operation and adjusted, if necessary. When changing double reduction models, each housing should be drained and filled independently, even though there may be a common level.

Initial oil change: The new oil in a speed reducer should be changed at the end of 250 hours of operation. This is equivalent to 30 days of operation for 8 hours per day; 15 days of operation for 16 hours per day, or 10 days of operation for 24 hours per day.

Subsequent oil changes: Under normal conditions, after the initial oil change, the oil should be changed after every 2500 hours of operation, or every 6 months, whichever occurs first. Under severe conditions (rapid temperature changes, moist, dirty or corrosive environment) it may be necessary to change oil at intervals of one to three months. Periodic examination of oil samples taken from the unit will help establish the appropriate interval.

Synthetic oils: Synthetic lubricants can be advantageous over mineral oils in that they generally are more stable, have a much longer life, and operate over a wider temperature range. These oils are appropriate for any application but are especially useful when units are subjected to low start-up temperatures or high operating temperatures. However, continuous operation above 225°F may cause damage to seals or other components. It is recommended that the initial oil be changed or filtered after the first 1500 hours of operation to remove metal particles that accumulate during break-in. Subsequent oil changes should be made after 5000 hours operation if units are operating in a clean environment. This can be extended to 10,000 hours if using new reformulated Mobil SHC lubricants (orange in color) and the lubricant remains free of contamination over this period. See comments under "Subsequent oil changes" for discussion of severe ambient conditions.

Long term storage or infrequent operation: If a speed reducer is to stand idle for an extended period of time, either prior to installation or during use, it is recommended that the unit be filled completely with oil to protect interior parts from rust and corrosion due to internal condensation. Be sure to drain the oil to the proper level before placing the speed reducer in service.

Grease fittings: Some units are equipped with grease fittings to lubricate bearings not adequately lubricated by the oil splash. These fittings must be lubricated every 3 - 6 months depending on operating conditions. bearing greases must be compatible with the type of gear lubricant being used (i.e. mineral, synthetic, food grade, etc.). For mineral oils, use a high quality lithium base NLGOI #2 bearing grease. For synthetic oils, use a synthetic bearing grease such as Mobil Synthetic Universal grease, Mobilith SHC 100 or a suitable equivalent. For food grade lubricants, use Chevron FM grease, NGLI 2, or equivalent.

Low input speeds (under 1600 RPM): When input speeds are less than 1600 RPM, grease fittings will be required to lubricate any bearings not partially covered by the normal oil level.

Oil temperature: Speed reducers in normal operation can generate temperatures up to 200°F depending on the type of reducer and the severity of the application (loading, duration of service, ambient temperatures). Excessive oil temperatures may be the result of several factors including overloading, overfilling, underfilling or inadequate cooling.

Size	Nominal Ratio											
	5	7.5	10	15	20	25	30	40	50	60	80	100
920	0.347	0.263	0.225	0.216	0.202	0.191	0.215	0.200	0.188	0.182	0.164	0.161

Lubricant selections are provided by the lubricant manufacturer based on AGMA recommended viscosity grades. Viscosity grades are based on Lubrication Standard ANSI/AGMA 9005-D94.

SECTION 4: TROUBLESHOOTING SECTION

SECTION 4: TROUBLESHOOTING

COMMON PROBLEMS



WARNING: Inspection, testing and repair of electrical equipment should be performed only by qualified service personnel. Certain procedures in this section require electrical tests or measurements while power is applied to the machine. **Exercise extreme caution at all times.** If test points are not easily accessible, disconnect power, attach test equipment and reapply power to test. When replacing electrical parts, disconnect power at source circuit breaker

Problem: Nothing on dishmachine operates. The power switch is ON and the power indicator light is OFF.

1. Machine is not wired correctly to incoming power source. Have an electrician verify wiring.
2. Machine circuit breaker is tripped. Reset the circuit breaker. If it trips again, contact an electrician to verify the machine amp draw.
3. Service breaker is tripped. Reset the service breaker. If it trips again, contact an electrician to verify the machine amp draw.

Problem: Machine will not fill. The power switch is ON and the power indicator light is ON.

1. No water supply to machine. Verify that water lines have been connected to the machine.
2. Dishmachine doors are not closed. Close doors completely.
3. Incoming water solenoid valve damaged/faulty. Verify that the valve is operating. If not, replace.
4. Tank floats faulty. Verify the wiring of the floats. Verify that no debris is jamming the floats. Replace if necessary.

Problem: Machine fills, but fill is weak.

1. Low incoming water pressure. Verify that incoming water pressure during fill is 20 ± 5 PSI.
2. Incoming water solenoid is clogged. Verify that debris is not entrapped in valve. If so, remove debris.

Problem: Low wash tank temperature.

1. Low incoming water temperature. Verify that the incoming water temperature matches what is indicated on the machine data plate.
2. Heater not energizing. Verify that the wash tank heater is operating. If not, replace.
3. Low incoming voltage. Have an electrician verify that the power coming to the machine is the same as indicated on the data plate.

Problem: Low wash arm pressure, poor spray pattern.

1. Clogged wash arm nozzles. Verify that nozzles are not clogged with debris. If so, remove debris.
2. Clogged wash tank or wash pump strainers. Clean out strainers if necessary.
3. Worn wash pump impeller. Verify status of impeller, replace if necessary.

Problem: Low prewash arm pressure, poor spray pattern.

1. Clogged prewash arm nozzles. Verify that nozzles are not clogged with debris. If so, remove debris.
2. Clogged prewash tank or prewash pump strainers. Clean out strainers if necessary.
3. Worn prewash pump impeller. Verify status of impeller, replace if necessary.

Problem: Inadequate rinse.

1. Low incoming water pressure. Verify that incoming water pressure during fill is 20 ± 5 PSI.
2. Incoming water solenoid is clogged. Verify that debris is not entrapped in valve. If so, remove debris.

Problem: Pawl bar moves with no load, but does not move when loaded.

1. Clutch on drive assembly is out of adjustment. Adjust as required.

SECTION 4: TROUBLESHOOTING

COMMON PROBLEMS

Problem: Pawl bar does not move.

1. Failed or broken overload spring. Replace spring if necessary.
2. No power to the drive motor/failed drive motor. Verify power and wiring connections to the motor. If necessary, replace the motor.
3. Pawl bar not properly installed. Verify that the pawl bar is installed correctly.

Problem: Racks go through the machine, but results are poor.

1. Verify that detergent is being dispensed into the machine at the appropriate quantities for the water volume. If not, get detergent to appropriate level and review results of washing ware.
2. Clogged strainers/scrap basket. Clean out strainers and scrap basket and replace.
3. Ware not being properly prescrapped. Review paragraph entitled "Ware Preparation" in Operating Instructions.
4. Wash or rinse arms missing end plugs or caps. Verify and replace as required.
5. Low tank heat.
6. Inadequate rinse.
7. Incorrect voltage coming to the machine. Verify that the voltage matches that on the machine data plate.
8. Wash pump cavitation due to low water level. Verify that the drains are shut and that the water level is correct.

Problem: Spotting of silverware, glasses and dishes.

1. Incorrect final rinse temperature. Verify that the rinse water temperature matches that which is listed on the machine data plate.
2. Clogged wash and/or rinse nozzles and arms. Remove the arms and verify that they and their nozzles are free from debris.
3. Excessively hard water. Install a water softener to reduce hardness.
4. Loss of water pressure due to clogged/obstructed wash pump. Turn the power off to the machine at the source. Drain the wash tank of water and verify that the pump intake is free from debris.
5. Improper scrapping procedures. Review the paragraph entitled "Ware Preparation" in Operating Instructions.
6. incorrect detergent/chemical concentrations. Verify that the detergent/chemical concentrations are correct for the associated water volume.

TORQUE SETTINGS

When replacing components either in the control box or the heater box area, the manufacturer has suggestions on how much to torque the screws and nuts used in securing items to the machine. Refer to the table below for the torque specifications:

<u>ITEMS</u>	<u>TORQUE SPEC</u>
Relays	16 In/lbs
Heater Contactor	35 In/lbs
Heater Nuts	16 In/lbs
Terminal Block	50 In/lbs

SECTION 5: PARTS SECTION

SECTION 5: PARTS SECTION

AJ-44T CONTROL BOX ASSEMBLY

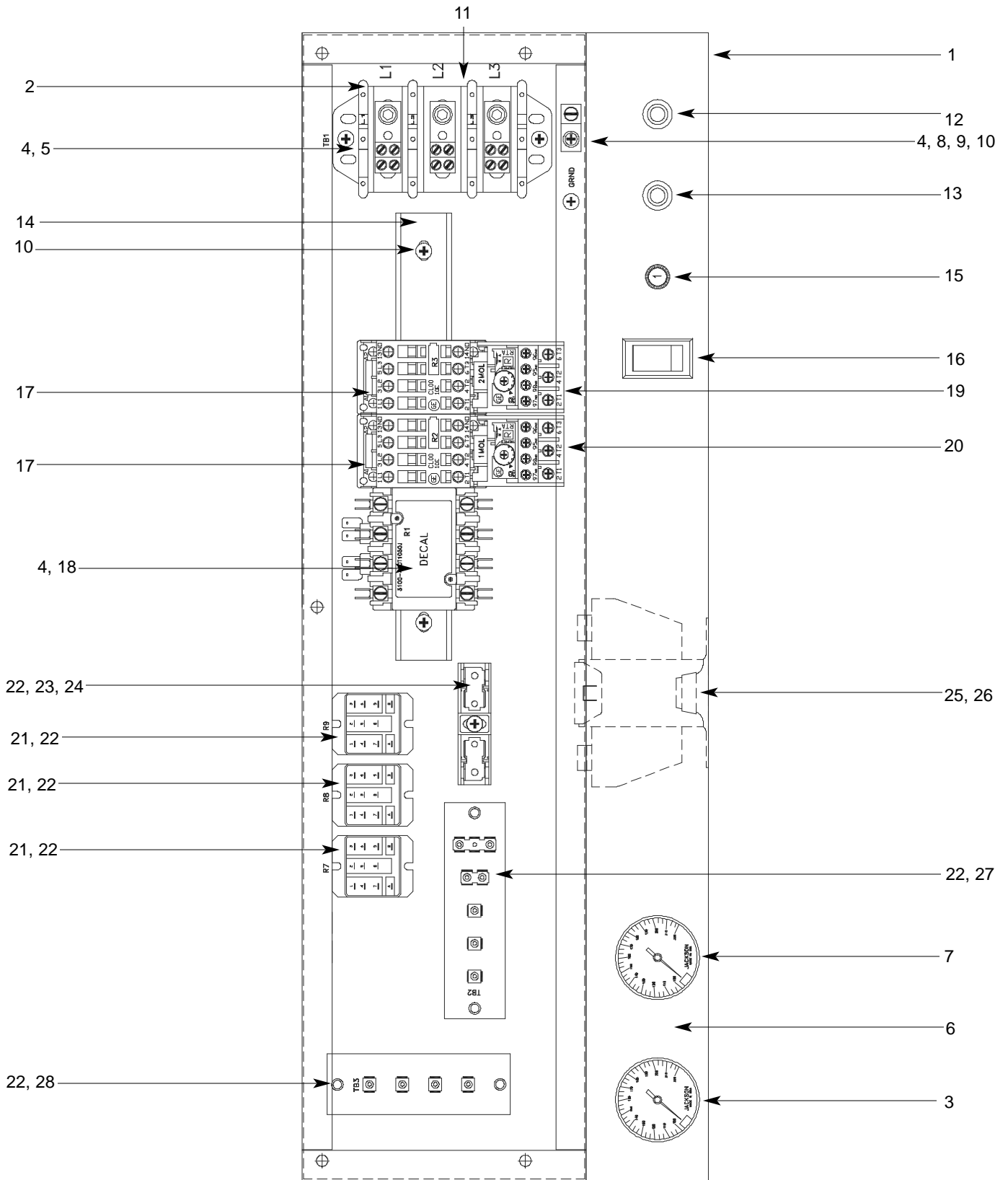

SECTION 5: PARTS SECTION
AJ-44 CONTROL BOX ASSEMBLY (CONTINUED)

ITEM	QTY	DESCRIPTION	Mfg. No.
1	1	Electrical Box Weldment	05700-041-88-43
2	1	Terminal Block, 3 Pole	05940-011-48-27
3	1	Rinse Thermometer, 96" Lead	06685-111-68-49
	1	Rinse Decal, 180°F	09905-002-97-62
4	6	Star Washer, External Tooth, 10-24	05311-273-02-00
5	6	Screw, 10-32 x 3/4" Long Phillips Trusshead	05305-011-62-17
6	1	Decal, Gauge	09905-021-72-29
7	1	Wash, Thermometer, 48" Lead	06685-111-68-48
	1	Wash Decal, 160°F	09905-003-00-69
8	1	Wire Lug, 2 AWG to 14 AWG	05940-200-76-00
9	1	Decal, Ground	09905-011-86-86
10	2	Screw, 10-32 x 1/2" Long Phillips Trusshead	05305-011-39-36
11	1	Decal, L1-L2-L3	09905-101-12-66
12	1	Light, Amber	05945-111-44-44
13	1	Light, Red	05945-111-44-45
14	1	Din Rail	05700-021-72-75
15	1	Circuit Breaker (200-380 Volt, 60 Hz Models Only)	05925-011-68-34
15	1	Circuit Breaker (TG Models Only)	05925-111-64-18
16	1	Switch, ON/FILL - OFF/DRAIN	05930-301-46-00
17	2	Motor Contactor	05945-111-68-38
18	1	Heater Contactor	05700-002-24-70
19	1	Overload	See Page 48
20	1	Overload	See Page 48
21	1	Control Relay	05945-111-35-19
21	2	Control Relay	05945-111-72-51
22	10	Screw, 6-32 x 3/8" Long Round Phillipshead	05305-002-25-91
23	1	Fuse (380 Volt-460 Volt, (all 60 Hz) Models Only)	05920-011-72-88
	1	Fuse, 600 Volt Models Only	05920-002-75-95
24	1	Fuse Holder for (23) Above	05920-011-72-89
25	1	Transformer	
		200 Volt Model	05950-002-41-47
		208-220-230-460 Volt Models	05950-011-68-35
		208-220-230-460 Volt TG Models	05950-002-46-10
		380-415 Volt Models	05950-011-75-59
		600 Volt Model	05950-002-23-77
26	4	Locknut, 10-24 with Nylon Insert	05310-373-01-00
27	1	Terminal Board	05940-002-78-97
28	1	Terminal Board	05940-021-89-41
29	2	Control Relay (TG Models Only (Not Shown))	05945-111-72-51

MISCELLANEOUS PARTS NOT SHOWN:

Grommet, 1/2" OD x 3/8" ID	05325-011-46-73
Bushing, Heyco SB100	05975-210-09-00
Plug, Heyco 2700 G-875	05975-011-47-81
Control Box Cover	05700-031-66-88
Control Box Cover Hinge Weldment	05700-021-68-57
Cotter Pin	05315-011-68-56
MANUAL/DELIME Switch (located on rear of control box)	05930-301-22-18
MANUAL/DELIME Switch Decal (located on rear of control box)	09905-011-74-61
Copper Conductors Only Decal	09905-011-47-35
Decal, Operation	09905-002-82-33
Decal, High Limit Light Warning	09905-002-49-48
Control Box Leg	05700-011-71-47
Component Mounting Plate (located inside the control box)	05700-031-67-03
Conduit Bracket	05700-021-70-88

SECTION 5: PARTS SECTION

AJ-66T & AJ-80T CONTROL BOX ASSEMBLY

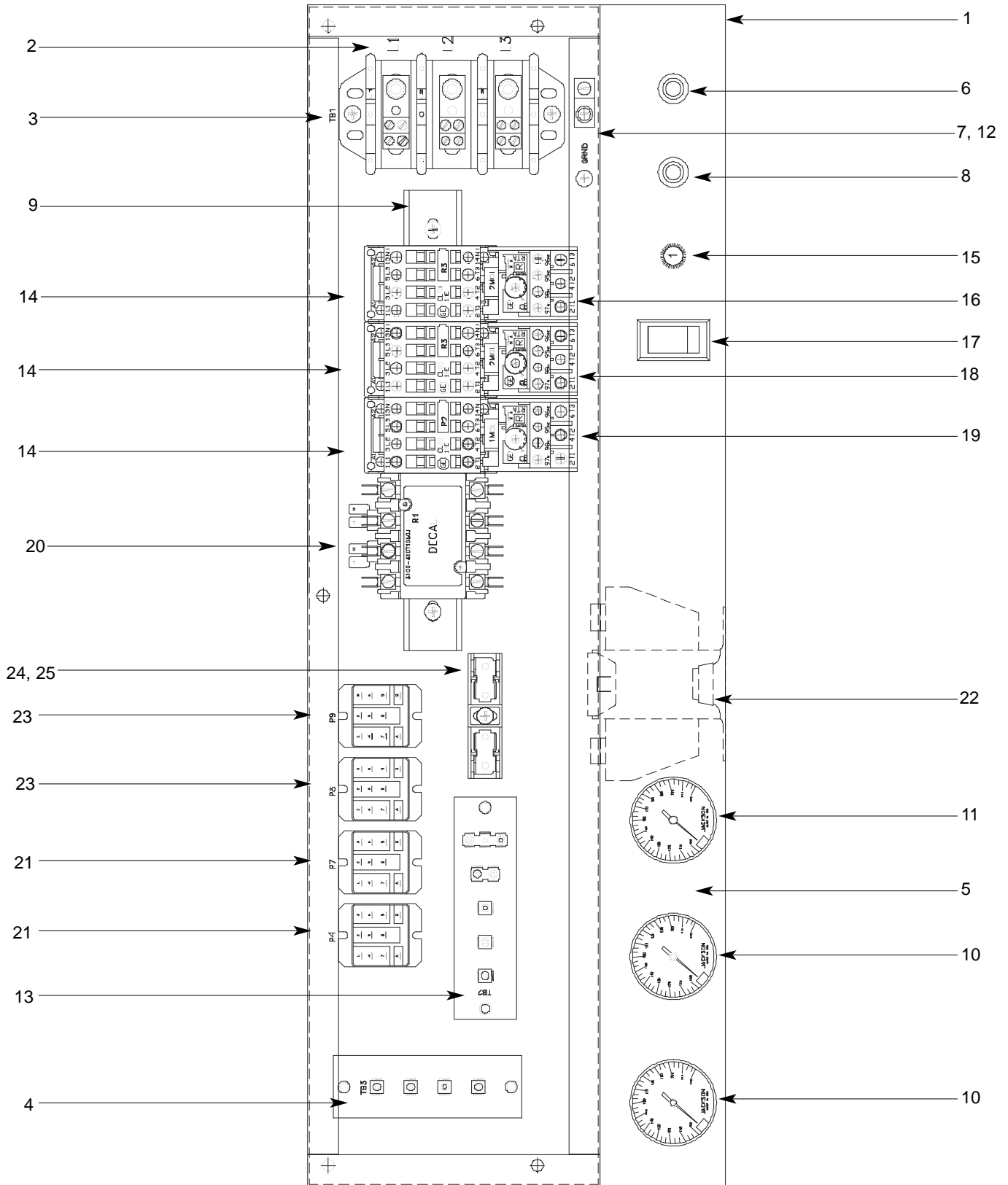

SECTION 5: PARTS SECTION

AJ-66 & AJ-80 CONTROL BOX ASSEMBLY (CONTINUED)

ITEM	QTY	DESCRIPTION	Mfg. No.
1	1	Electrical Box Weldment	05700-041-88-50
2	1	Decal, L1-L2-L3	09905-101-12-66
3	1	Terminal Block	05940-011-48-27
4	1	Terminal Board	05940-021-89-41
5	1	Decal, Gauge	09905-021-72-30
6	1	Light, Amber	05945-111-44-44
7	1	Wire Lug, 2 AWG to 14 AWG	05940-200-76-00
8	1	Light, Red	05945-111-44-45
9	1	Din Rail	05700-021-72-75
10	2	Thermometer, 96" Lead Rinse Decal, 180°F	06685-111-68-49 09905-002-97-62
11	1	Thermometer, 48" Lead Wash Decal, 160°F	06685-111-68-48 09905-003-00-69
12	1	Decal, Ground	09905-011-86-86
13	1	Terminal Board	05940-002-78-97
14	3	Motor Contactor	05945-111-68-38
15	1	Circuit Breaker (200/208/230/360 Volt, 60 Hz Models Only)	05925-011-68-34
15	1	Circuit Breaker (TG Models Only)	05925-111-64-18
16	1	Overload	See Page 48
17	1	Switch, ON/FILL & OFF/DRAIN	05930-301-46-00
18	1	Overload	See Page 48
19	1	Overload	See Page 48
20	1	Heater Contactor (for non-steam units)	05945-002-24-70
21	2	Relay	05945-111-72-51
22	1	Transformer (200 Volt Models Only)	05950-002-41-47
		Transformer (208/220/230/460 Models Only)	05950-011-68-35
		Transformer (208-220-230-460 Volt TG Models)	05950-002-46-10
		Transformer (380/415 Volt Models Only)	05950-011-75-59
		Transformer (600 Volt Models Only)	05950-002-23-77
23	2	Control Relay	05945-111-35-19
24	1	Fuse Holder (380 (60 Hz)/460/600 Volt Models Only)	05920-011-72-89
25	1	Fuse (380 (50 Hz)/460 Volt Models Only)	05920-011-72-88
	1	Fuse (600 Volt Models Only)	05920-002-75-95
26	2	Control Relay (TG Models Only (Not Shown))	05945-111-72-51
MISCELLANEOUS PARTS NOT SHOWN:			
		Manual/Delime Switch	05930-301-22-18
		Manual/Delime Switch Decal	09905-011-74-61
		Decal, Operation	09905-002-82-33
		Decal, High Limit Warning Light	09905-002-49-48
		Control Box Cover	05700-031-66-88
		Control Box Leg	05700-011-71-47
		Conduit Bracket	05700-021-70-88

SECTION 5: PARTS SECTION
MOTOR OVERLOAD CHART

<u>Model</u>	<u>Volts</u>	<u>Hz</u>	<u>Phase</u>	<u>Drive Motor</u>	<u>Prewash Motor</u>	<u>Wash Motor</u>	
AJ-44T'S	208	50	3	05945-011-84-59	N/A	05945-111-68-40	
	220	50	3	05945-011-84-59	N/A	05945-111-68-40	
	230	50	3	05945-011-84-59	N/A	05945-111-68-40	
	380	50	3	05945-002-71-09	N/A	05945-111-68-40	
	415	50	3	05945-111-69-12	N/A	05945-111-81-33	
	440	50	3	05945-111-69-12	N/A	05945-111-81-33	
	208	60	1	N/A	N/A	N/A	
	230	60	1	N/A	N/A	N/A	
	200	60	3	05945-002-66-00	N/A	05945-002-65-99	
	208	60	3	05945-111-68-39	N/A	05945-111-68-40	
	230	60	3	05945-111-68-39	N/A	05945-111-68-40	
	380	60	3	05945-111-69-12	N/A	05945-111-81-33	
	460	60	3	05945-111-68-39	N/A	05945-111-68-40	
	600	60	3	05945-111-69-12	N/A	05945-111-81-33	
	AJ-66T'S	200	50	3	05945-011-84-59	05945-002-65-98	05945-111-68-40
		208	50	3	05945-011-84-59	05945-002-24-70	05945-111-68-40
		220	50	3	05945-011-84-59	05945-002-24-70	05945-111-68-40
		230	50	3	05945-011-84-59	05945-002-24-70	05945-111-68-40
		380	50	3	05945-002-71-09	05945-002-24-70	05945-111-68-40
		415	50	3	05945-111-69-12	05945-002-24-70	05945-111-81-33
440		50	3	05945-111-69-12	05945-002-24-70	05945-111-81-33	
208		60	1	N/A	N/A	N/A	
230		60	1	N/A	N/A	N/A	
200		60	3	05945-002-66-00	05945-002-66-02	05945-002-65-99	
208		60	3	05945-111-68-39	05945-111-68-41	05945-111-68-40	
230		60	3	05945-111-68-39	05945-111-68-41	05945-111-68-40	
380		60	3	05945-111-69-12	05945-002-24-70	05945-111-81-33	
460		60	3	05945-111-68-39	05945-111-68-41	05945-111-68-40	
600		60	3	05945-111-69-12	05945-111-81-33	05945-111-81-33	
AJ-80T'S		200	50	3	05945-011-84-59	05945-111-68-40	05945-111-68-40
		208	50	3	05945-011-84-59	05945-111-68-40	05945-111-68-40
		220	50	3	05945-011-84-59	05945-111-68-40	05945-111-68-40
		230	50	3	05945-011-84-59	05945-111-68-40	05945-111-68-40
		380	50	3	05945-002-71-09	05945-111-68-40	05945-111-68-40
	415	50	3	05945-111-69-12	05945-111-81-33	05945-111-81-33	
	440	50	3	05945-111-69-12	05945-111-81-33	05945-111-81-33	
	208	60	1	N/A	N/A	N/A	
	230	60	1	N/A	N/A	N/A	
	200	60	3	05945-002-66-00	05945-002-65-99	05945-002-65-99	
	208	60	3	05945-111-68-39	05945-111-68-40	05945-111-68-40	
	230	60	3	05945-111-68-39	05945-111-68-40	05945-111-68-40	
	380	60	3	05945-111-69-12	05945-111-81-33	05945-111-81-33	
	460	60	3	05945-111-68-39	05945-111-68-40	05945-111-68-40	
	600	60	3	05945-111-69-12	05945-111-81-33	05945-111-81-33	

SECTION 5: PARTS SECTION
HEATER BOX ASSEMBLY

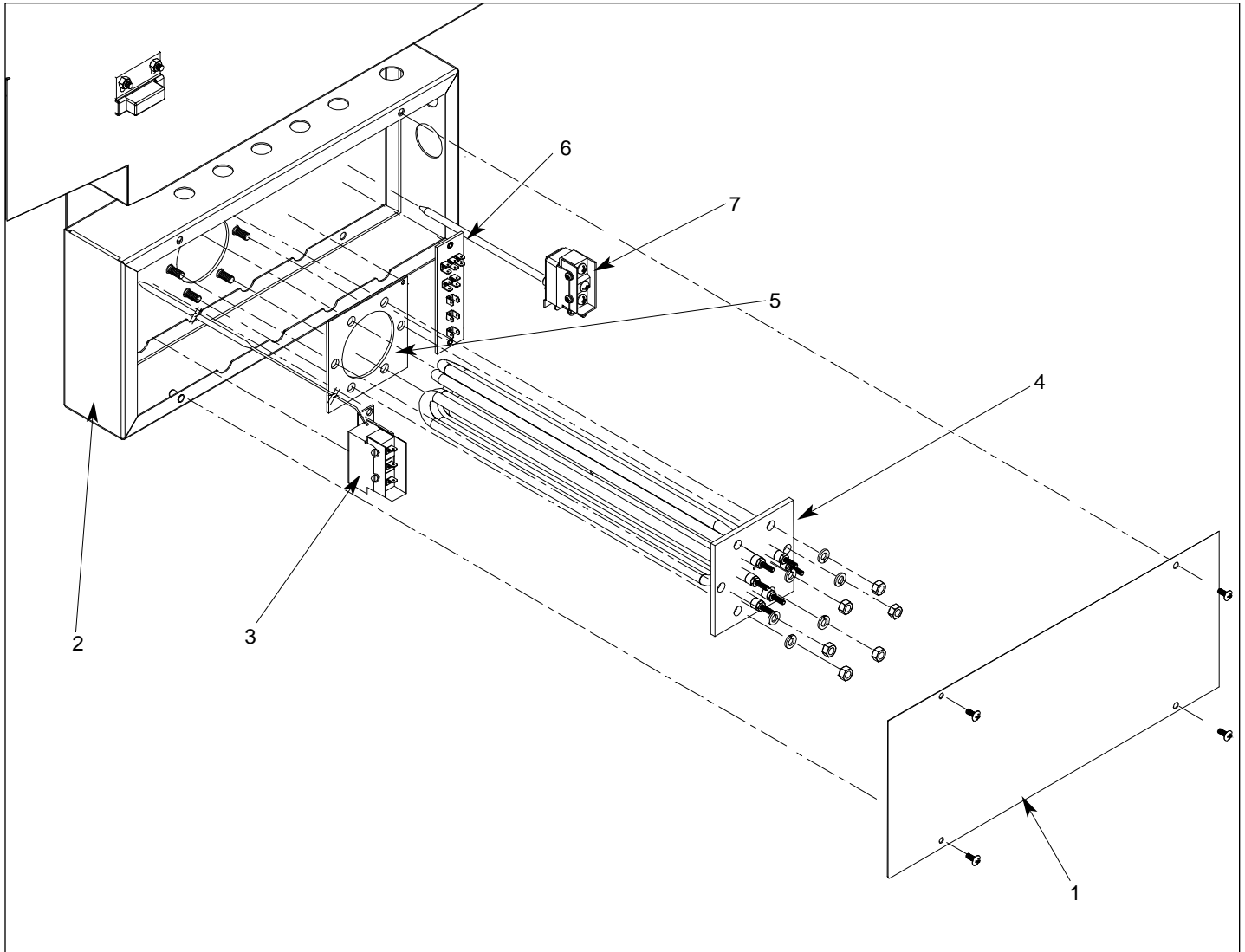

ITEM	QTY	DESCRIPTION	Mfg. No.
1	1	Heater Box Cover	05700-002-02-04
2	1	Heater Box Weldment	05700-002-98-38
3	1	Thermostat, High Limit	05930-011-49-43
	1	Fitting, 1/4", Imperial Brass	05310-924-02-05
4	1	See Next Page	N/A
5	1	Gasket	05330-200-02-70
6	1	Terminal Board	05940-002-78-97
7	1	Kit, Wash Regulating Thermostat (TE Series)	06401-003-18-20
7	1	Kit, Wash Regulating Thermostat (TS Series)	06401-003-18-21

SECTION 5: PARTS SECTION
HEATER BOX ASSEMBLY (CONTINUED)

5/16"-18 Hex Nut
 05310-275-01-00

See Heater Chart Below

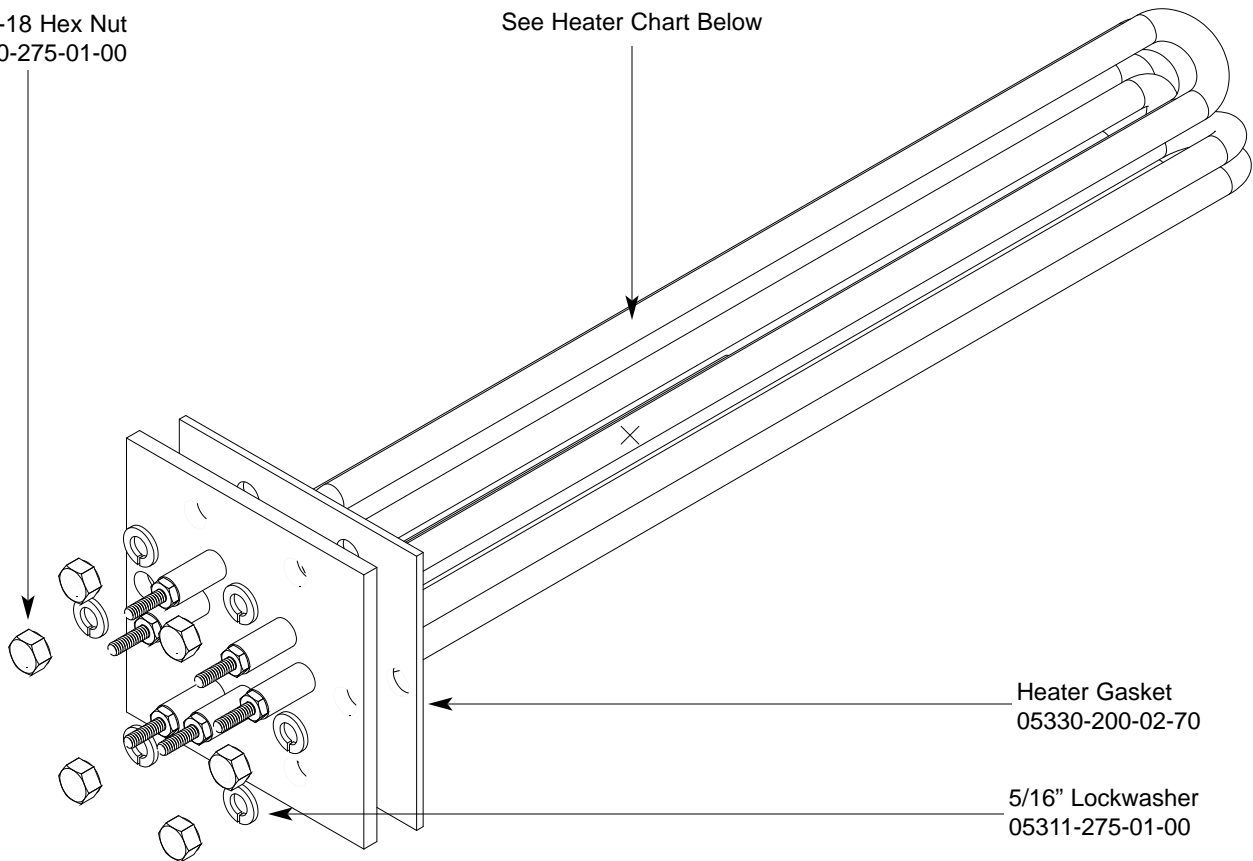

Heater Gasket
 05330-200-02-70

5/16" Lockwasher
 05311-275-01-00

Heater Chart

<u>Model</u>	<u>Volts</u>	<u>Phase</u>	<u>KW</u>	<u>Part Number</u>
All*	208	1	18	04540-121-79-30
	230	1	18	04540-121-79-31
	200	3	18	04540-121-79-30
	208	3	18	04540-121-79-30
	220	3	18	04540-121-79-31
	230	3	18	04540-121-79-31
	380	3	18	04540-003-08-51
	415	3	18	04540-003-08-52
	440	3	18	04540-003-08-53
	460	3	18	04540-121-79-32
	575	3	18	04540-003-06-22
	600	3	18	04540-003-06-22

* - Gas and steam models do not use electric heaters in the wash tank or power rinse tank.

SERVICE NOTE: When replacing the tub heaters, it is HIGHLY recommended that you also change out the gasket as well. Once installed, gaskets become compressed and are subjected to extreme temperature changes. Replacing the gasket with a new one when replacing the heater may prevent future leaks.

SERVICE NOTE: The nuts used to secure the heater to the tub should be torqued to 16 in-lbs. After tightening, the unit should be allowed to heat up and operate normally for approximately 30 minutes. Secure power to the machine and check the nuts once more to ensure that they are torqued to 16 in-lbs.

SECTION 5: PARTS SECTION

HEATER BOX ASSEMBLY (CONTINUED)

The wash tank heater system is electrically connected in the circuit so that they are dependent upon the dishwasher being properly filled with and maintaining a safe water level, two thermostats (mounted in the heater box behind the dress panel), float switch (mounted in the wash tank), and the heater relay (mounted in control box) with the heater being activated by the thermostats.

Once the dishwasher has been filled to the correct level, the heater should operate automatically. Should the tank heat be too high, too low or no indication of temperatures at all, the following checkout should be made.

Note: The following checkout should be made by either a qualified service person or electrician.

A- Checkout of the heater system

- 1- If the temperature is too high, adjust thermostat using instructions in the section entitled "Thermostats".
- 2- If temperature is too low, adjust thermostat as above, then:
 - a - Turn off power to machine by placing customer's circuit breaker in the "OFF" position. Turn off machine circuit breaker located on right side of control box.
 - b - Remove cover from control box on top of dishwasher.
 - c - Make sure water temperature is below 140°F.(preferably about 130°F.).
 - d - Turn on both circuit breakers. Observe heater relay (R1) while the power switch is turned "ON" and "OFF". If relay contacts move in and out, the heater relay is operating correctly: if not proceed to "C".

B- If heater relay (R1) closes:

- 1 - Check power supply at incoming terminal board L1, L2 & L3. It should be the same voltage as indicated on the machine data plate.
- 2 - Check power at connections on heater relay (R1). The voltage should agree with the voltage on the machine data plate. If not, check wires for breaks or bad connections.
- 3 - Check power at terminals of heater which should agree with the data plate. If not check wires for breaks or bad connections.
- 4 - Temperatures should rise as explained in "C-1", and amperage may be checked according to those instructions. Replace any defective elements.

C - If heater relay (R1) does not close.

- 1 - There is an insulated movable insulated movable bar on relay across the top. With an insulated probe, depress this bar and observe the thermometer: the temperature should rise noticeably in a minute or two. If it moves slowly, it would indicate that the element is faulty. If it moves constantly higher at a good rate, elements should be good.



Note: A check with an amp probe at heater relay (R1) terminals should be made to verify the amp draw on each leg. This should be appropriate for the voltage and phase indicated on the data plate.

HEATER PROTECTION & AUTOMATIC FILL (FOR UNITS EQUIPPED WITH AUTOMATIC FILL)

This control is activated when the power switch is turned "ON". The primary function is to automatically energize the wash tank heat circuit. It will also cutoff the wash tank heat circuit should the water be accidently drained from the machine with the power switch still "ON". The power switch should always be turned-off before draining the unit.

This water level control consists of two (2) floats that operate when the power switch is turned on and works in conjunction with the thermostats and heater relays.

When the power switch is turned "ON" water starts to enter the dishmachine. When it reaches the proper level the normally open contacts in the water level float switch close activating the heating circuit for tank heat.

If the water level below the correct level while power is still on, the float switch will sense the lack of water and de-activate the heater.

SECTION 5: PARTS SECTION

HEATER BOX ASSEMBLY (CONTINUED)FRAME ASSEMBLY/DRESS PANELS

THERMOSTATS

The thermostat range is from 140°F to 240°F with a maximum bulb exposure temperature of 300°F.

Calibration:

Wash Thermostat: Set Point: 165°F (Adjustable range)

Hi-Limit Thermostat: Fixed set point: 210°F (Non-adjustable)

The hi-limit thermostat is used to protect the heater element in the event of a run away regulating thermostat or a dry fire situation. It is set for 210°F +0°F or -10°F with a fixed set point. **This part is not adjustable.**

The wash tank regulating thermostat will maintain the correct wash water temperature to meet NSF requirements. These specify that the wash be no lower than 140°F on chemical sanitizing models and no lower than 160°F on hot water sanitizing machines.

FRAME WELDMENTS

<u>Model</u>	<u>Left to Right Part Number</u>	<u>Right to Left Part Number</u>
AJ-44T's	05700-031-67-15	05700-031-67-15
AJ-66T's	05700-002-49-28	05700-002-57-57
AJ-80T's	05700-031-74-07	05700-002-32-14

Bullet Feet (4 per model) - order using part number 05340-011-71-74.

FRONT DRESS PANELS

<u>Model</u>	<u>Left to Right Part Number</u>	<u>Right to Left Part Number</u>
AJ-44T's	05700-031-72-22	05700-031-72-22
AJ-44TG	05700-002-52-77	05700-002-52-77
AJ-66T's	05700-002-51-22	05700-002-57-84
AJ-66TG	05700-002-51-22	05700-002-57-84
AJ-80T's	05700-031-74-06	05700-031-77-10

SECTION 5: PARTS SECTION
PREWASH INCOMING PLUMBING ASSEMBLY

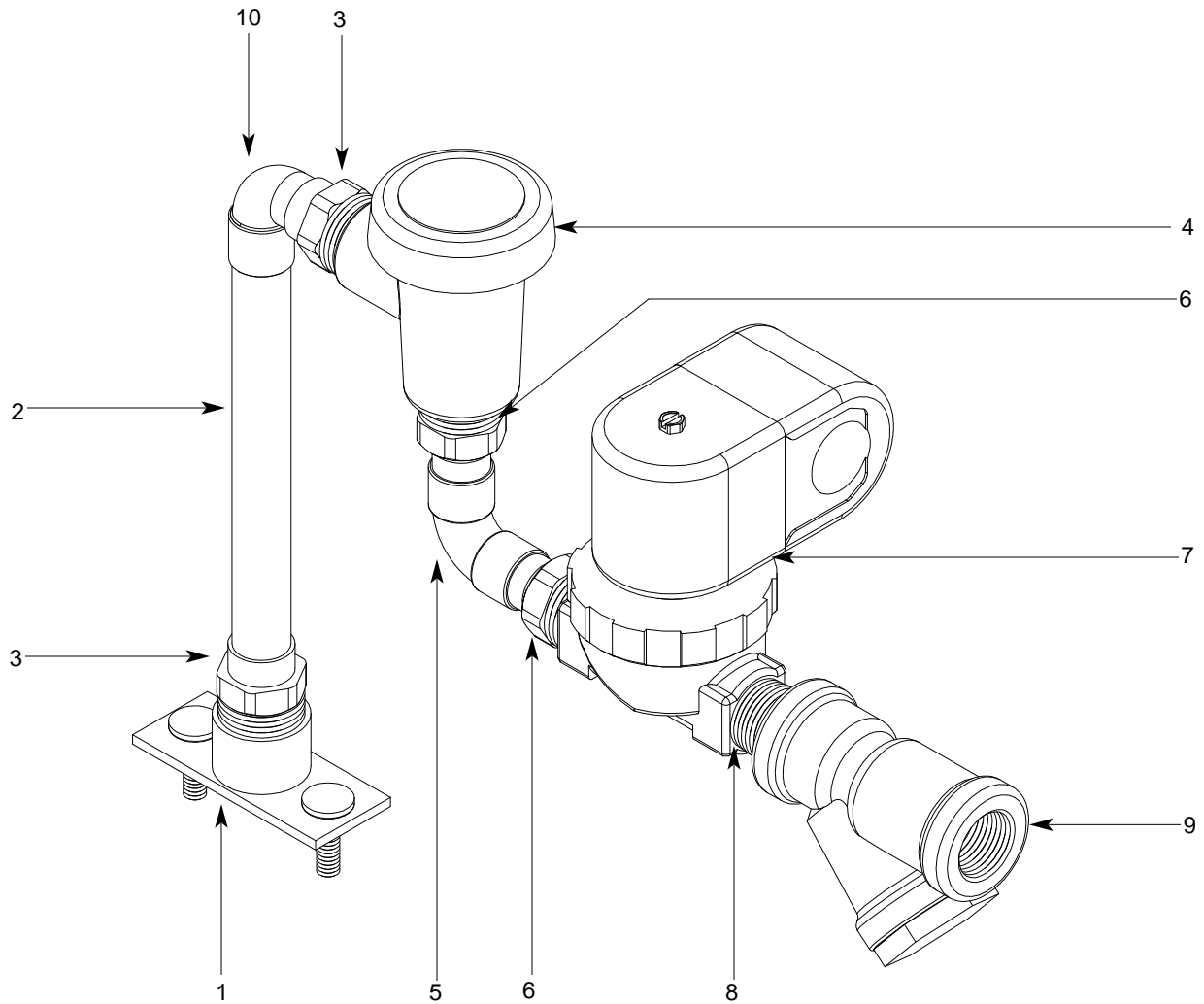

ITEM	QTY	DESCRIPTION	Mfg. No.
1	1	Fill Line Injector Weldment	05700-002-04-71
	1	Gasket	05330-111-42-81
2	1	Tube, Copper, 1/2" x 5.645" Long	05700-002-04-90
3	2	Adapter, Male	04730-401-03-01
4	1	Vacuum Breaker	04820-003-06-13
5	1	Elbow, 607, 1/2" CTOC	04730-406-01-01
6	2	Adapter, 1/2" FTG x Male	04730-011-59-53
7	1	Valve, Solenoid, 1/2" NPT, 110 Volt	04810-100-12-18
8	1	Nipple, 1/2", Close, Brass	04730-207-15-00
9	1	Y-Strainer, 1/2" NPT	04730-217-01-10
10	1	Elbow, 1/2" S. CU to Ftg.	04730-406-31-01

SECTION 5: PARTS SECTION
INCOMING RINSE PLUMBING ASSEMBLY

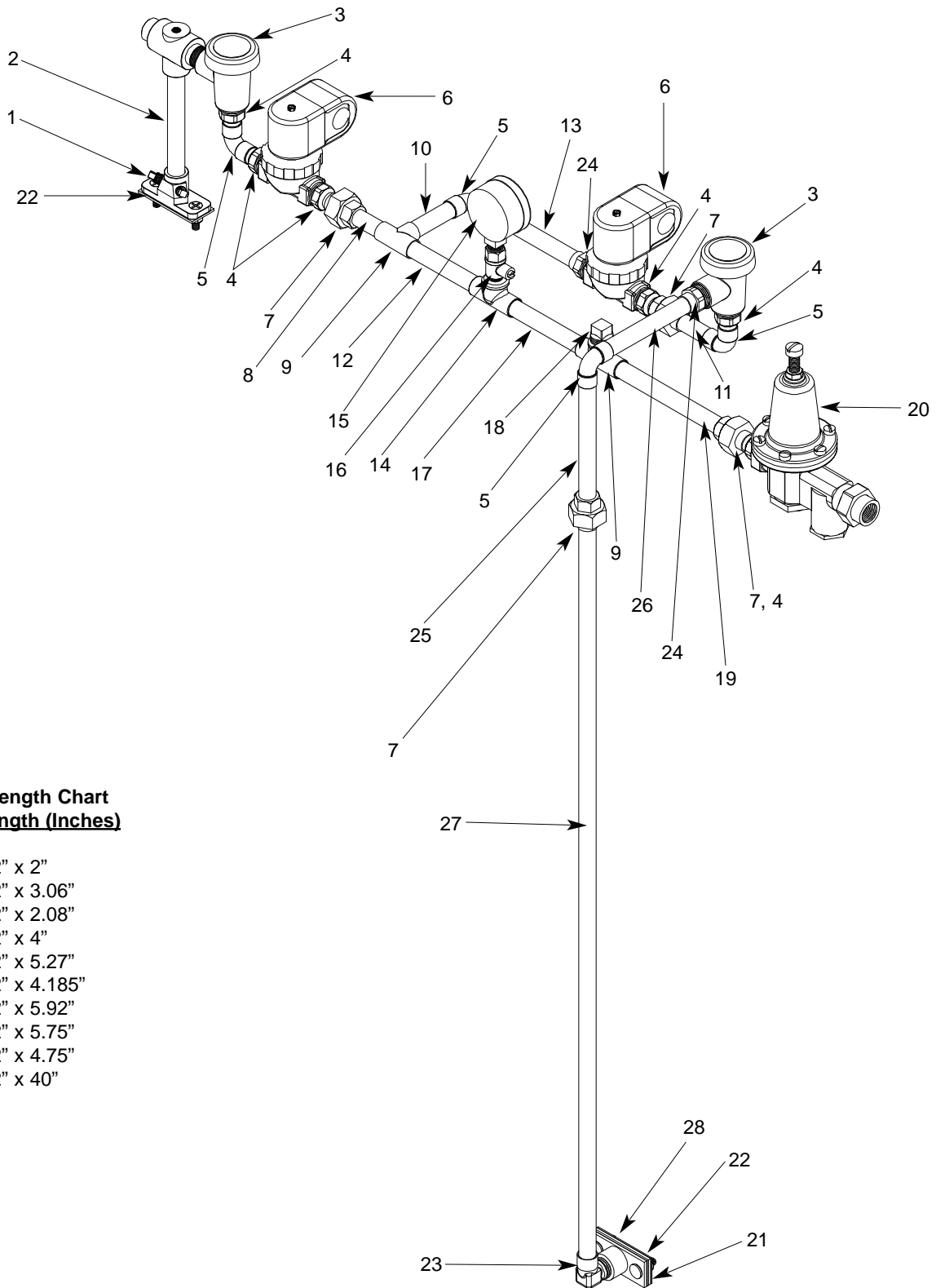

Tube Length Chart
Item # Length (Inches)

8	1/2" x 2"
10	1/2" x 3.06"
11	1/2" x 2.08"
12	1/2" x 4"
13	1/2" x 5.27"
17	1/2" x 4.185"
19	1/2" x 5.92"
25	1/2" x 5.75"
26	1/2" x 4.75"
27	1/2" x 40"

SECTION 5: PARTS SECTION
INCOMING RINSE PLUMBING ASSEMBLY (CONTINUED)

ITEM	QTY	DESCRIPTION	Mfg. No.
1	2	Plug, 1/8" NPT, Brass	04730-209-07-37
2	1	Rinse Injector Weldment	05700-002-03-42
	1	Gasket	05330-111-42-81
3	2	Vacuum Breaker, 1/2" NPT	04820-003-06-13
4	6	Adapter, 1/2" Fitting x Male	04730-011-59-53
5	3	Elbow, 607, 1/2" Copper to Copper	04730-406-01-01
6	2	Valve, Solenoid, 1/2" NPT, 110 Volt	04810-100-12-18
7	4	Union, 1/2", Copper to Copper	04730-412-05-01
8	1	Tube, Copper	See Chart
9	1	Tee, Copper, 1/2"	04730-411-01-01
10	1	Tube, Copper	See Chart
11	1	Tube, Copper	See Chart
12	1	Tube, Copper	See Chart
13	1	Tube, Copper	See Chart
14	2	Tee, 1/2" x 1/2" x 1/4"	04730-411-25-01
15	1	Gauge, Pressure, 0-100 PSI	06685-111-88-34
	1	Decal, 15-25 PSI	09905-002-97-74
16	1	Test Cock, Valve, Ball, 1/4" NPT	04810-011-72-67
17	1	Tube, Copper	See Chart
18	1	Plug, 1/4" NPT, Brass	04730-209-01-00
19	1	Tube, Copper	See Chart
20	1	Regulator, Watts, 1/2" (Not used on GP units)	04820-100-04-07
20	1	Elbow, 90°, 1/2" Street Brass (GP units only)	04730-206-08-00
21	1	Plate, Rinse Plumbing	05700-011-82-86
22	2	Gasket	05330-111-42-81
23	1	Elbow, 90° 1/2" Copper to MSPS	04730-406-32-01
24	2	Adapter, Male	04730-401-03-01
25	1	Tube, Copper	See Chart
26	1	Tube, Copper	See Chart
27	1	Tube, Copper	See Chart
28	1	Plate, Deflector	05700-002-62-49

SECTION 5: PARTS SECTION
TG SERIES INCOMING RINSE PLUMBING ASSEMBLY

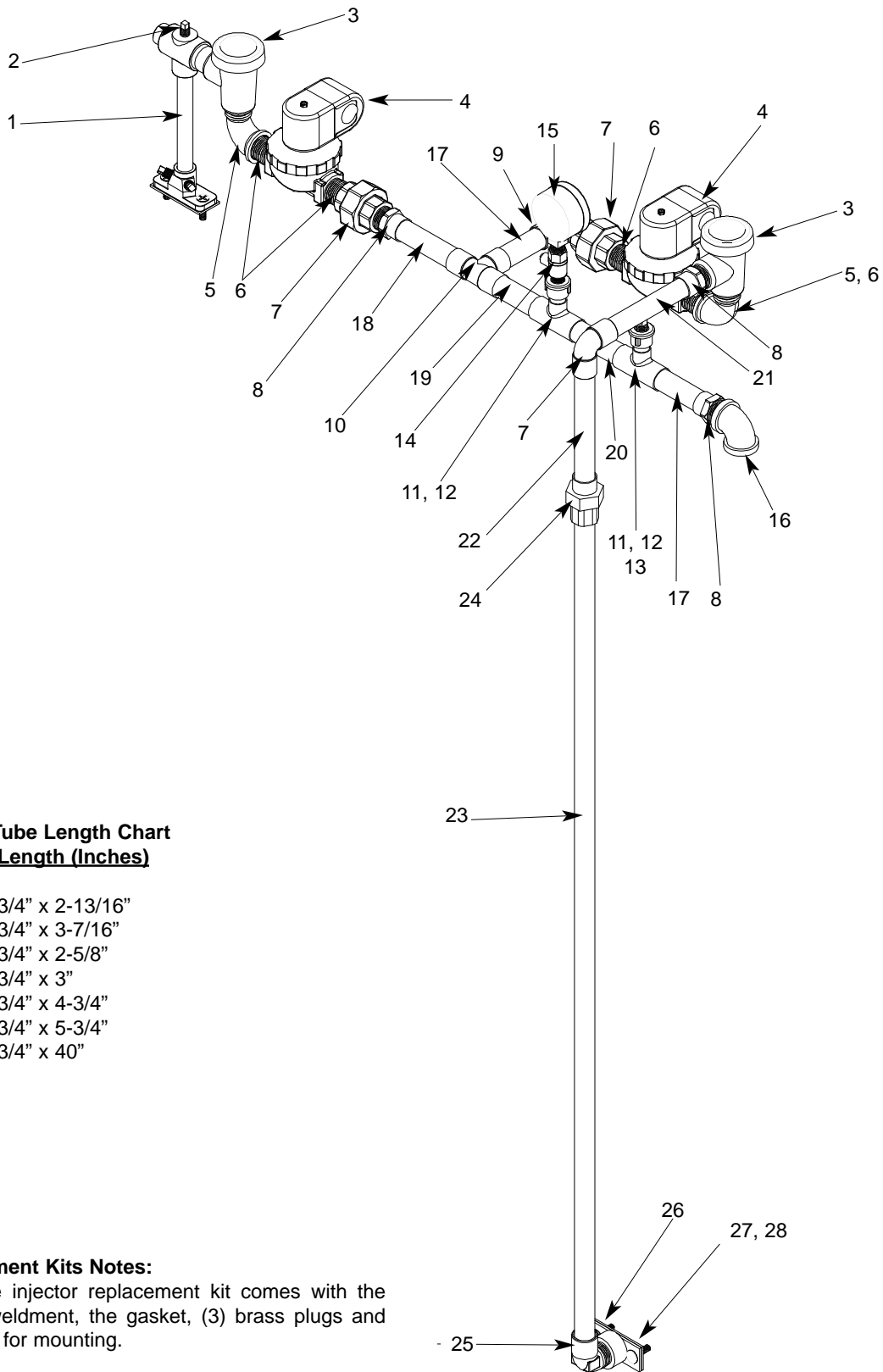

Tube Length Chart

Item #	Length (Inches)
17	3/4" x 2-13/16"
18	3/4" x 3-7/16"
19	3/4" x 2-5/8"
20	3/4" x 3"
21	3/4" x 4-3/4"
22	3/4" x 5-3/4"
23	3/4" x 40"

Replacement Kits Notes:

The rinse injector replacement kit comes with the injector weldment, the gasket, (3) brass plugs and hardware for mounting.

SECTION 5: PARTS SECTION

TG SERIES INCOMING RINSE PLUMBING ASSEMBLY (CONTINUED)

ITEM	QTY	DESCRIPTION	Mfg. No.
1	1	Rinse Injector Weldment Replacement Kit	06401-003-11-84
	1	Gasket	05330-111-42-81
2	3	Plug, 1/8" NPT, Brass	04730-209-07-37
3	2	Vacuum Breaker, 3/4" NPT	04820-002-53-77
4	2	Valve, Solenoid, 3/4" NPT, 110 Volt	04810-100-53-00
5	2	Elbow, 3/4" Street Brass	04730-206-04-34
6	4	Nipple, Close, Brass, 3/4" NPT	04730-207-34-00
7	2	Union, 3/4", NPT Copper to Copper	04730-212-05-00
8	2	Adapter, 3/4" Fitting x Male	04730-401-11-01
9	1	Elbow, 90° 3/4" Copper to MSPS	04730-406-42-01
10	1	Tee, 3/4", CU x CU x CU	04730-411-46-01
11	2	Tee, 3/4" x 3/4" x 1/2"	04730-411-03-01
12	2	Fitting, Adapter, 1/2" to 1/4"	04730-401-41-01
13	1	Plug, 1/4" NPT, Brass	04730-209-01-00
14	1	Test Cock, Valve, Ball, 1/4" NPT	04810-011-72-67
15	1	Gauge, Pressure, 0-100 PSI	06685-111-88-34
16	1	Elbow, 3/4" NPT, 90° Brass	04730-206-13-00
17-23	1	Tube, Copper	See Chart
24	1	Union, 3/4", Copper to Copper	04730-412-06-01
25	1	Elbow, 90° 1/2" Copper to MSPS	04730-406-32-01
26	1	Fill Line Injector Weldment	05700-002-04-71
27	2	Gasket	05330-111-42-81
28	1	Plate, Deflector	05700-002-62-49

SECTION 5: PARTS SECTION

RINSE SOLENOID VALVE & VACUUM BREAKER REPAIR PARTS KITS

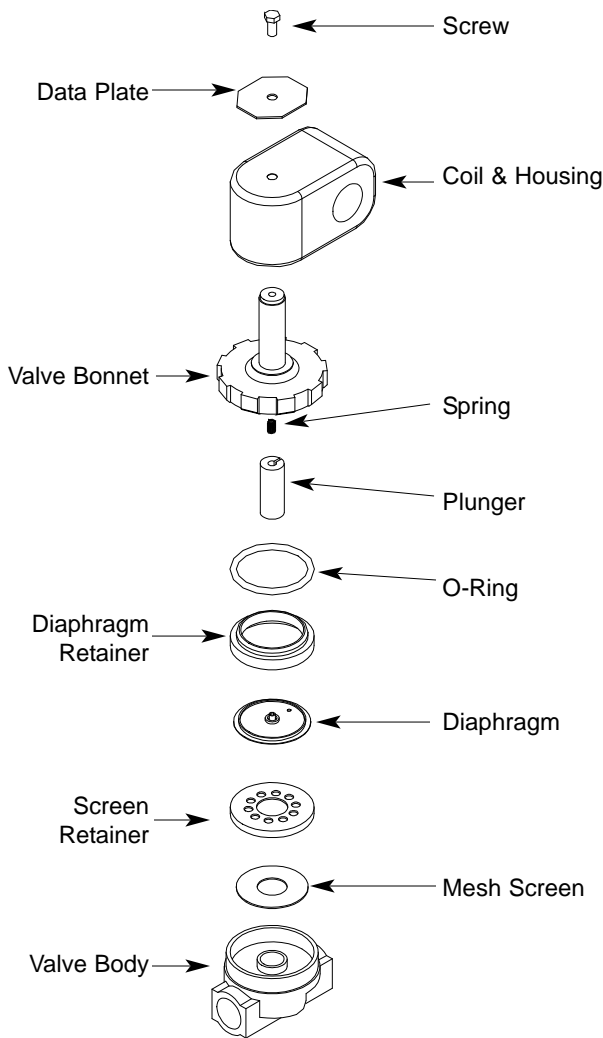

SPECIAL PARTS

- Solenoid Valve Plunger Kit
Includes plunger and spring
Part number 06401-003-07-40
- Solenoid Valve Diaphragm Kit
Includes diaphragm and o-ring
Part number 06401-003-07-41 (1/2" NPT)
- Solenoid Valve 110 Volt Coil and Housing Kit
Part number 06401-003-07-43
- Complete Solenoid Valve
Part number 04810-100-12-18 (1/2", 110 Volt)

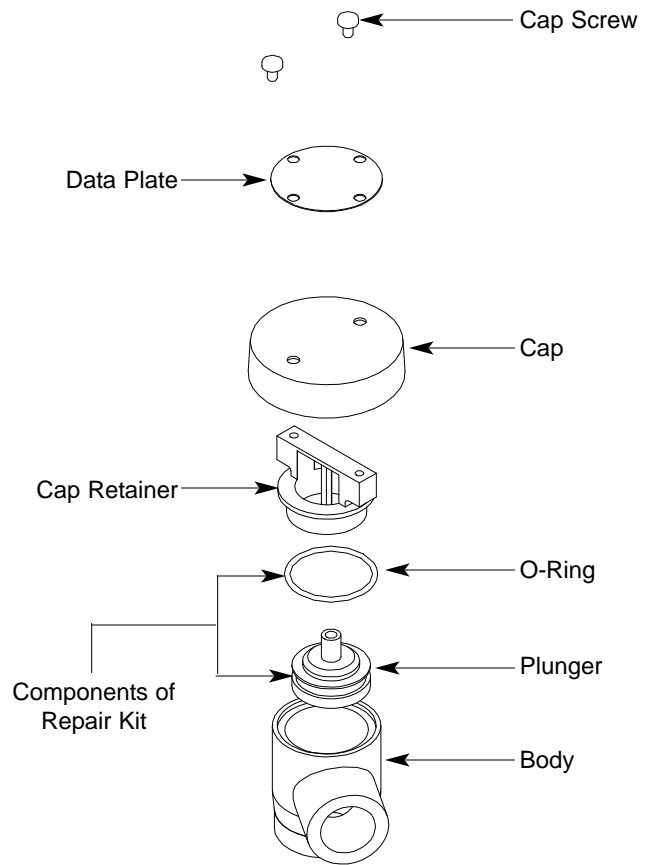

SPECIAL PARTS

- Vacuum breaker repair kit:
For 1/2" NPT order 06401-003-06-23
- Complete Vacuum Breaker Assembly
Part number 04820-003-06-13 (1/2")

SECTION 5: PARTS SECTION
STEAM UNIT WASH TANK COIL ASSEMBLY

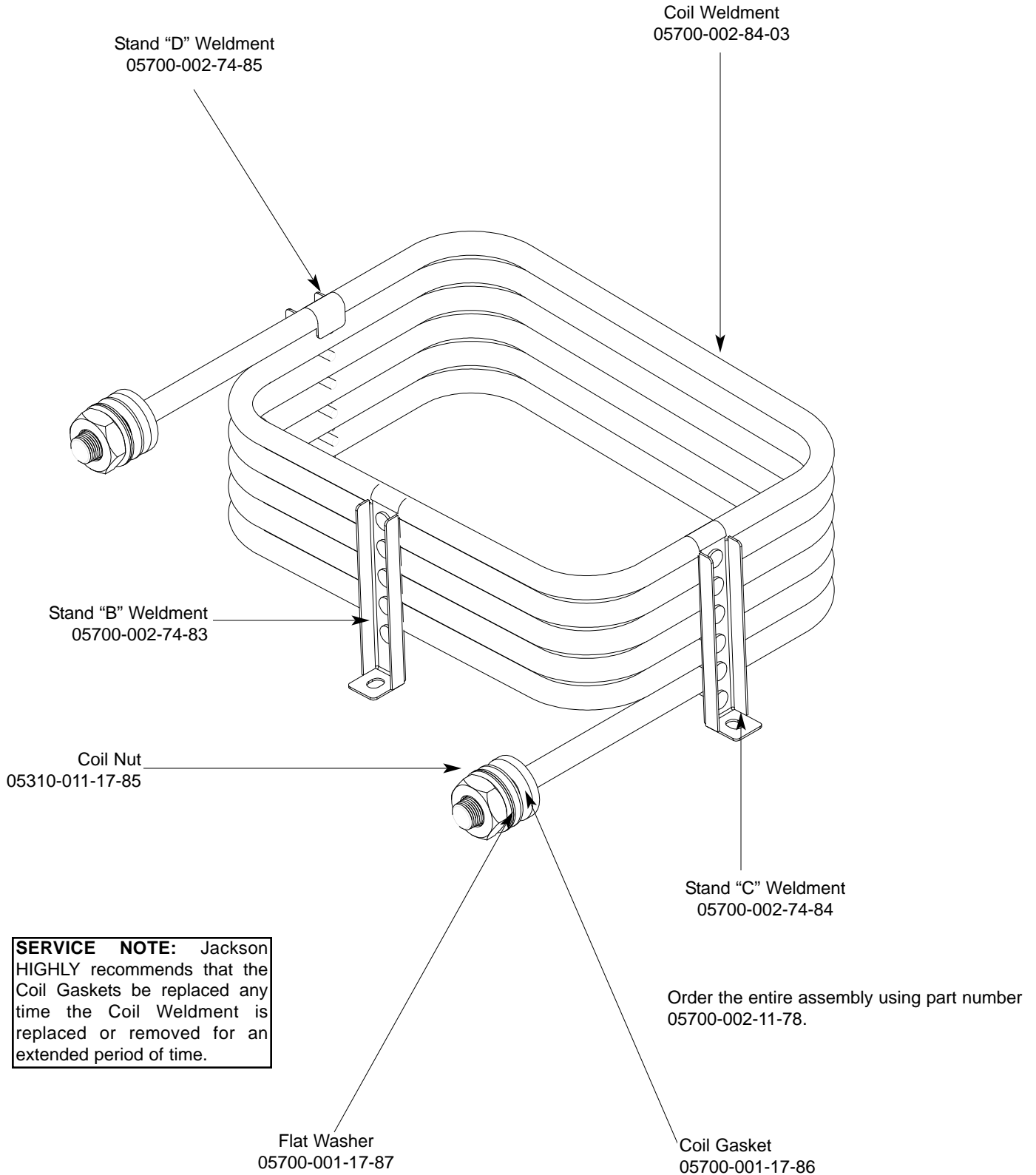

SECTION 5: PARTS SECTION

STEAM PLUMBING (LEFT TO RIGHT)

STEAM INLET PLUMBING

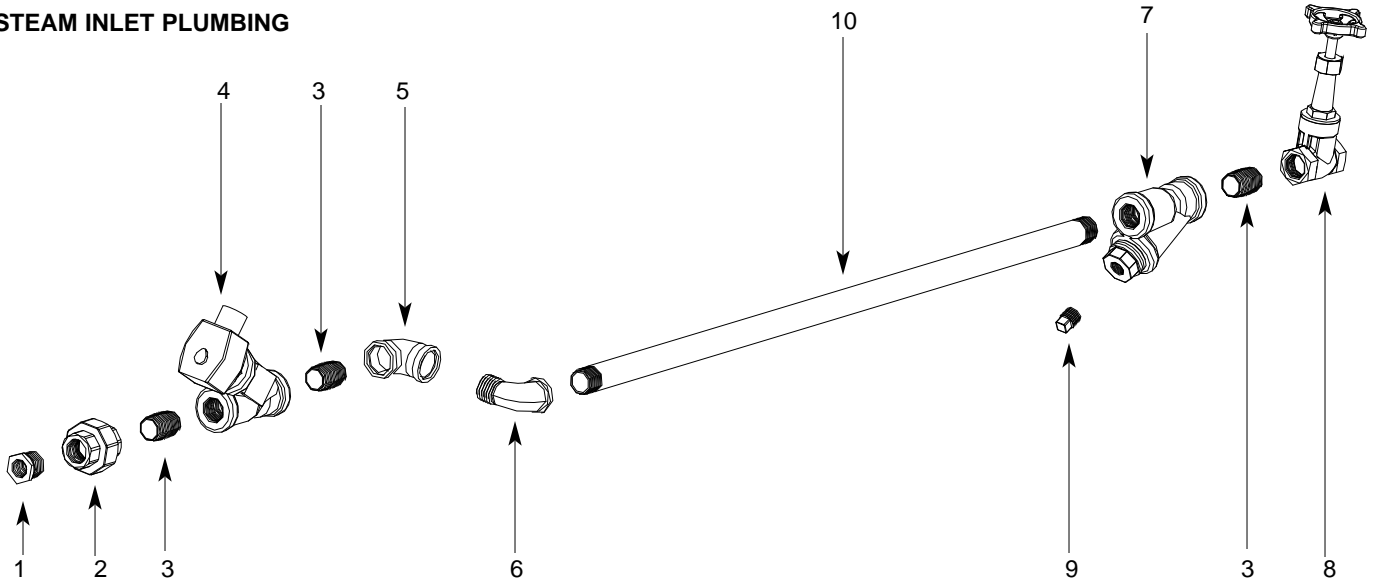

ITEM	QTY	DESCRIPTION	Mfg. No.
1	1	Reducer, 3/4" NPT to 1/2" NPT, Black Iron	04730-911-02-34
2	1	Union, 3/4" NPT, Black Iron	04730-912-01-00
3	3	Nipple, Close, 3/4" NPT, Black Iron	04730-907-01-00
4	1	Valve, Steam Solenoid, 3/4" NPT, 120V	04820-011-87-39
5	1	Elbow, 90°, 3/4" FNPT, Black Iron	04730-906-10-34
6	1	Elbow, Street, 90°, 3/4" NPT, Black Iron	04730-011-87-37
7	1	Y-Strainer, 3/4" NPT, Black Iron	04730-217-01-32
8	1	Valve, Gate, Steam, 3/4" NPT	04820-100-19-00
9	1	Plug, 3/8" NPT, Black Iron	04730-909-02-34
10	1	Nipple, 3/4" NPT x 32" Long	04730-002-21-27
11	1	Reducer, 3/4" NPT to 1/2" NPT, Black Iron	04730-911-02-34
12	1	Elbow, 90°, 3/4" FNPT, Black Iron	04730-906-10-34
13	1	Elbow, Street, 3/4" NPT, Black Iron	04730-011-87-37
14	1	Union, 3/4" NPT, Black Iron	04730-912-01-00
15	1	Nipple, Close, 3/4" NPT, Black Iron	04730-907-01-00
16	1	Steam Trap, 3/4" NPT	06680-500-02-77
17	1	Pipe, 3/4" NPT x 10" Long, Black Iron	04730-907-06-34

STEAM OUTLET PLUMBING

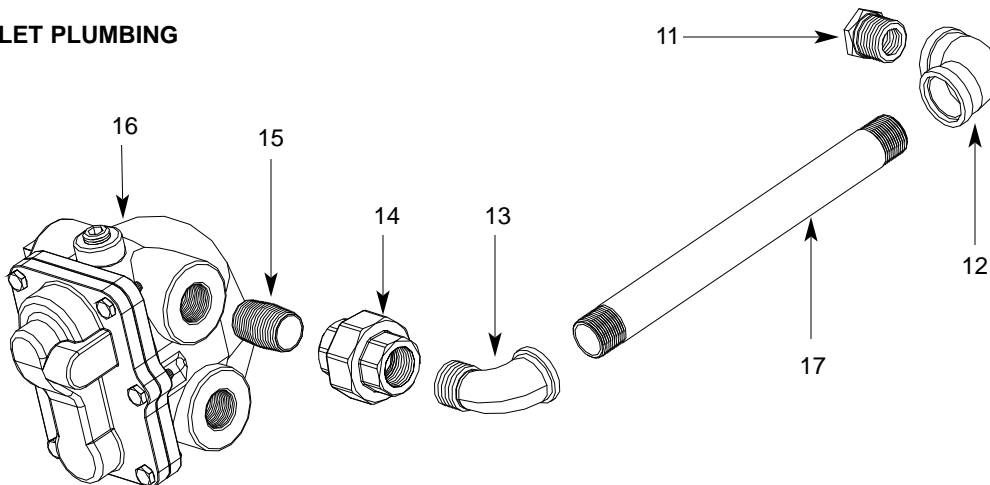

SECTION 5: PARTS SECTION
STEAM PLUMBING (RIGHT TO LEFT)

STEAM INLET PLUMBING

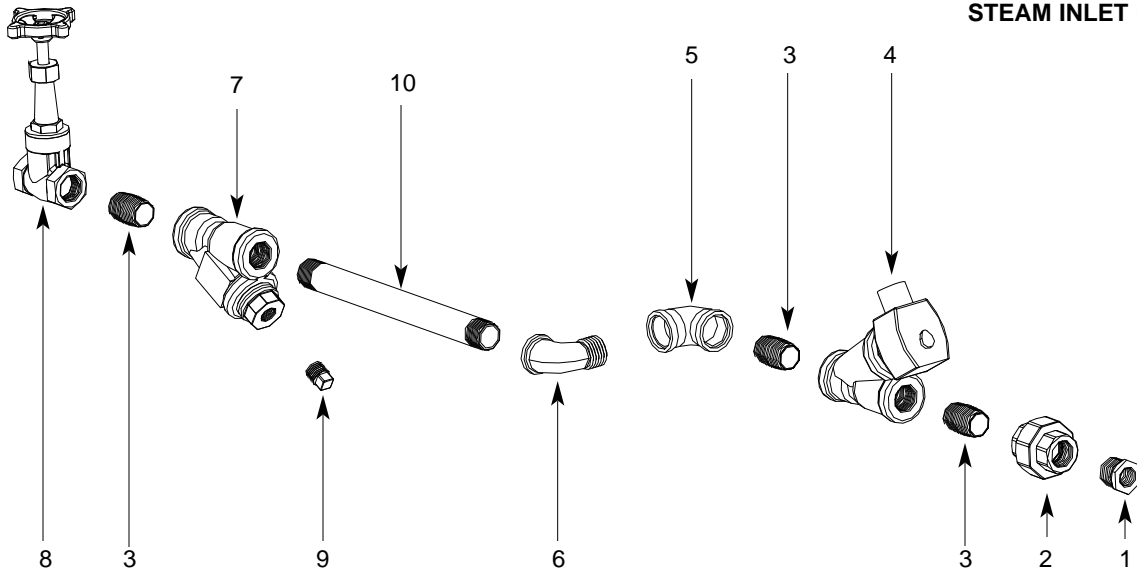

ITEM	QTY	DESCRIPTION	Mfg. No.
1	1	Reducer, 3/4" NPT to 1/2" NPT, Black Iron	04730-911-02-34
2	1	Union, 3/4" NPT, Black Iron	04730-912-01-00
3	3	Nipple, Close, 3/4" NPT, Black Iron	04730-907-01-00
4	1	Valve, Steam Solenoid, 3/4" NPT, 120V	04820-011-87-39
5	1	Elbow, 90°, 3/4" FNPT, Black Iron	04730-906-10-34
6	1	Elbow, Street, 90°, 3/4" NPT, Black Iron	04730-011-87-37
7	1	Y-Strainer, 3/4" NPT, Black Iron	04730-217-01-32
8	1	Valve, Gate, Steam, 3/4" NPT	04820-100-19-00
9	1	Plug, 3/8" NPT, Black Iron	04730-909-02-34
10	1	Nipple, 3/4" NPT x 10" Long	04730-907-06-34
11	1	Reducer, 3/4" NPT to 1/2" NPT, Black Iron	04730-911-02-34
12	1	Elbow, 90°, 3/4" FNPT, Black Iron	04730-906-10-34
13	1	Elbow, Street, 3/4" NPT, Black Iron	04730-011-87-37
14	1	Union, 3/4" NPT, Black Iron	04730-912-01-00
15	1	Nipple, Close, 3/4" NPT, Black Iron	04730-907-01-00
16	1	Steam Trap, 3/4" NPT	06680-500-02-77
17	1	Pipe, 3/4" NPT x 10" Long, Black Iron	04730-907-06-34

STEAM OUTLET PLUMBING

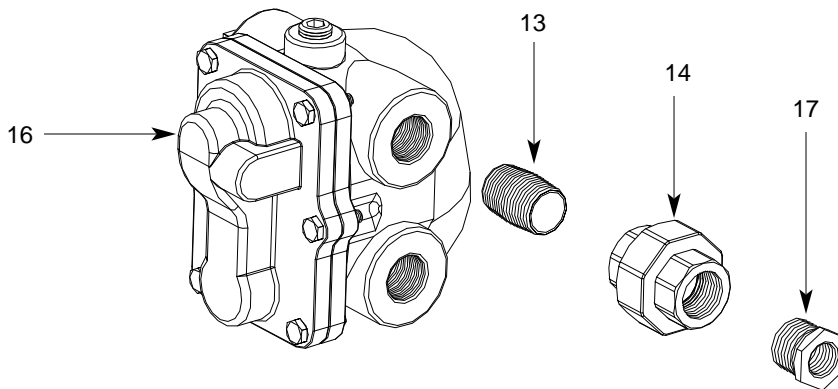

SECTION 5: PARTS SECTION
GAS COIL ASSEMBLY (TG MODELS)

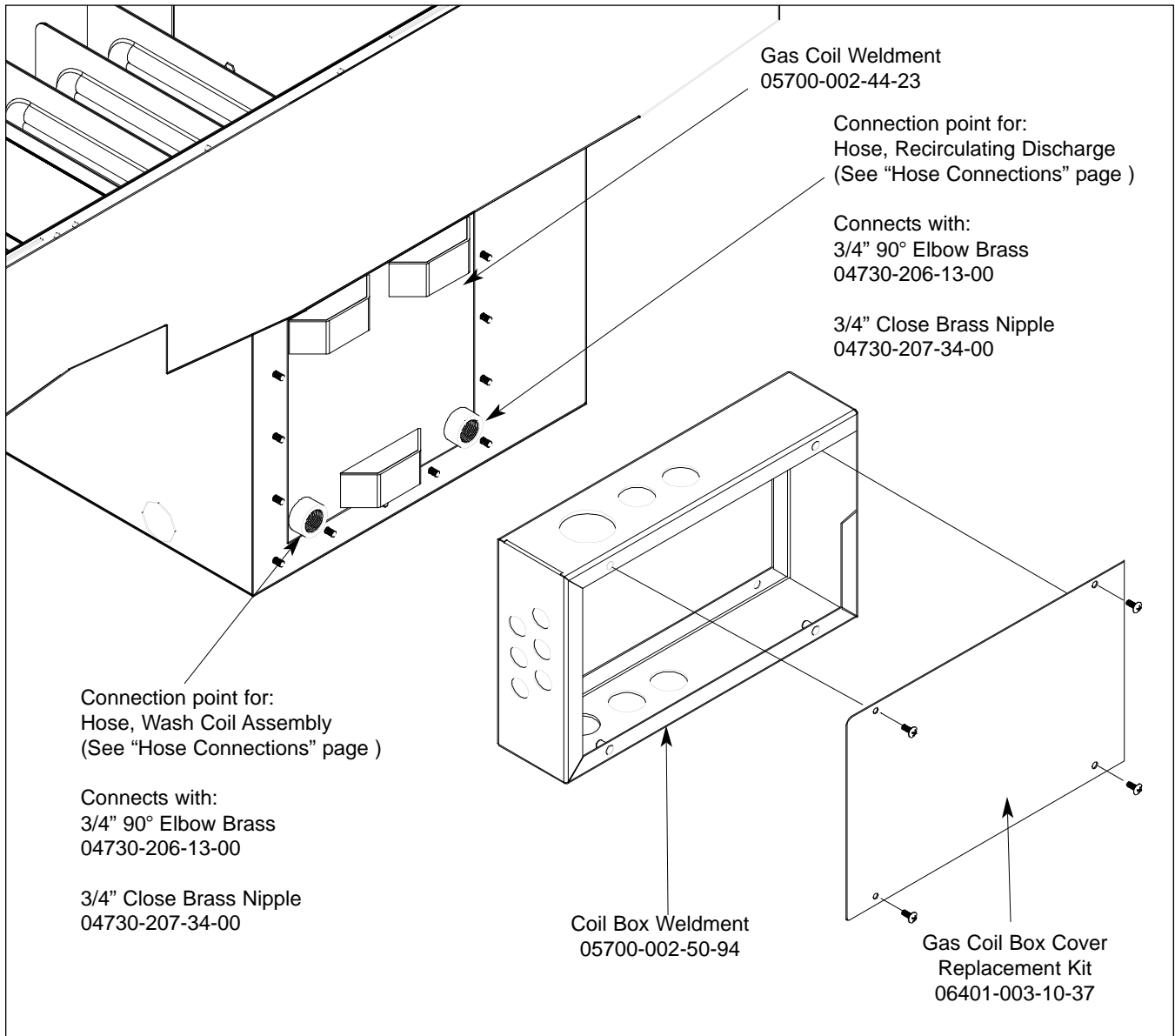

Other items used but not shown.

ITEM	QTY	DESCRIPTION	Mfg. No.
1	1	Thermostat, High Limit	05930-011-49-43
2	1	Terminal Board	05940-002-78-97
3	1	Thermostat Bracket	05700-011-81-64
4	1	Decal, Thermostat Regulating	09905-011-84-31
5	1	Thermostat, Wash Regulating	06401-140-00-32
6	2	Fitting, 1/4", Imperial Brass	05310-924-02-05

SECTION 5: PARTS SECTION
TANK, RINSE BOOSTER (TG MODELS ONLY)

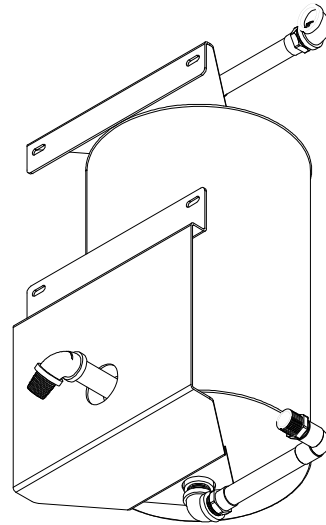
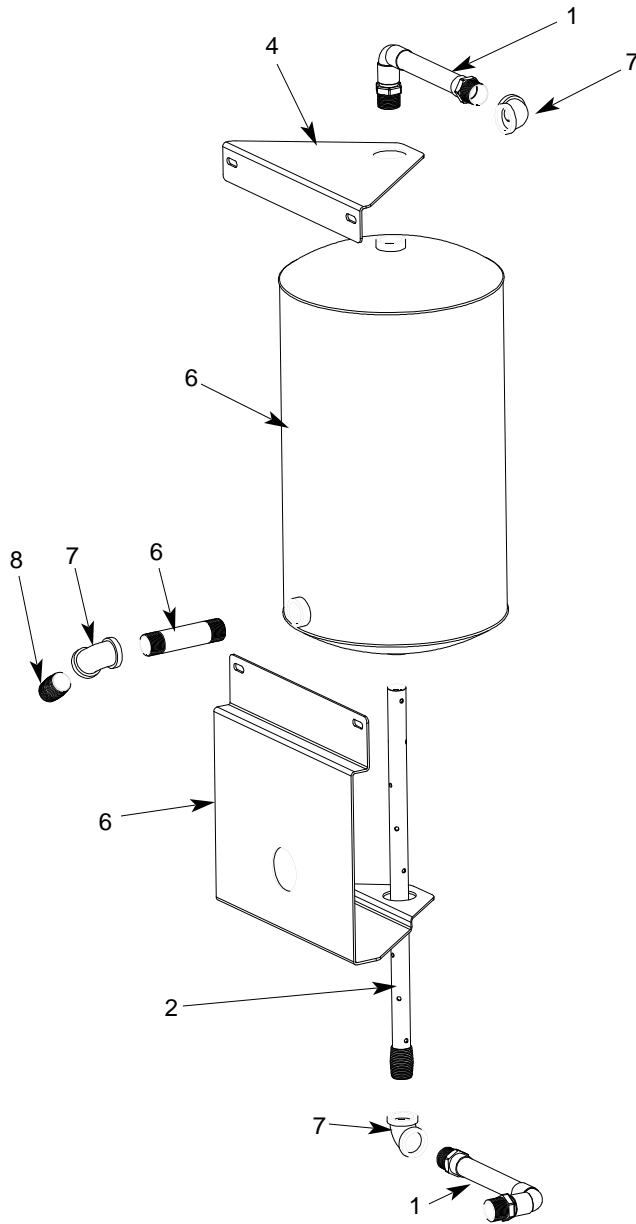

BOTTOM ANGLED VIEW

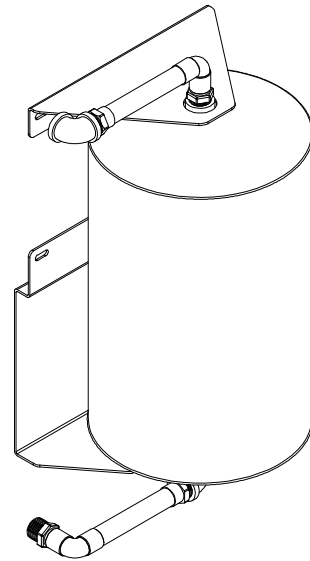

TOP ANGLED VIEW

ITEM	QTY	DESCRIPTION	Mfg. No.
1	2	Plumbing Assembly, Inlet/Discharge, Rinse Tank	05700-002-51-24
2	1	Tube, Dispersion Weldment	05700-002-46-16
3	1	Tank, GP Rinse	05700-002-45-05
4	1	Bracket, Upper Rinse Tank	05700-002-67-13
5	1	Bracket, Lower Rinse Tank	05700-002-67-14
6	1	Nipple, 3/4" NPT x 4" Long	04730-207-05-00
7	3	Elbow, 3/4" NPT, 90° Brass	04730-206-13-00
8	1	Nipple, 3/4" NPT x Closed Brass	04730-207-34-00

SECTION 5: PARTS SECTION
RECIRCULATING PUMP ASSEMBLY (TG MODELS ONLY)

Elbow, 3/4" 90° Brass
 2 per
 04730-206-13-00

Pump, Recirculating with Adapters
 05700-002-51-28

Nipple, 3/4" Close Brass
 2 per
 04730-207-34-00

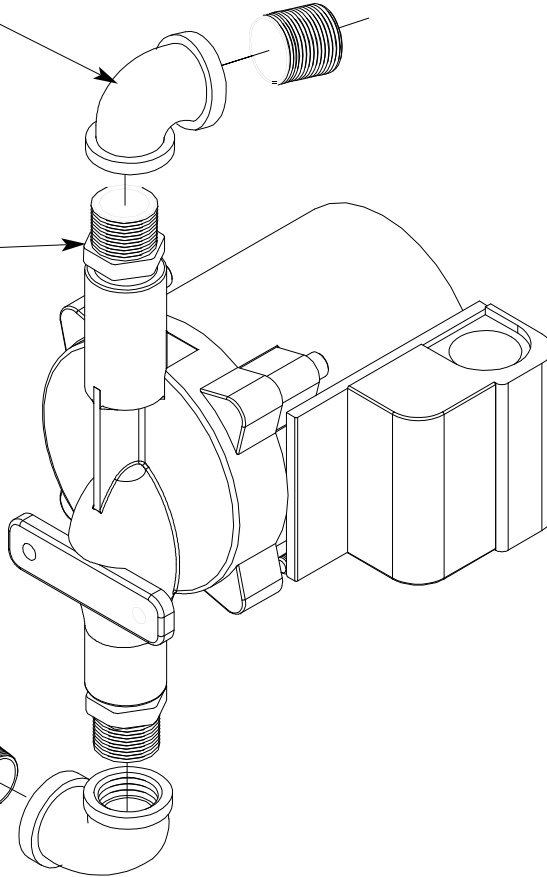

Used on AJ-44CGP, AJ-66CGP, AJ-80CGP units right to left units and the AJ-44CGP left to right unit.

Used only on AJ-66CGP/AJ-80CGP left to right units.

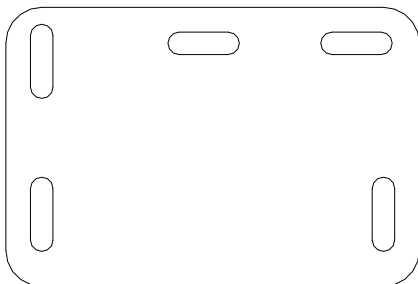

Mounting Bracket
 05700-002-25-74

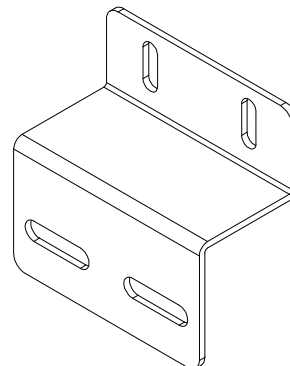

Mounting Bracket
 05700-002-23-61

SECTION 5: PARTS SECTION
HOSE CONNECTIONS (TG MODELS ONLY)

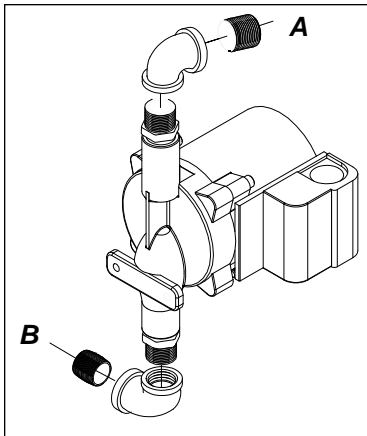

Recirculating Pump Assembly

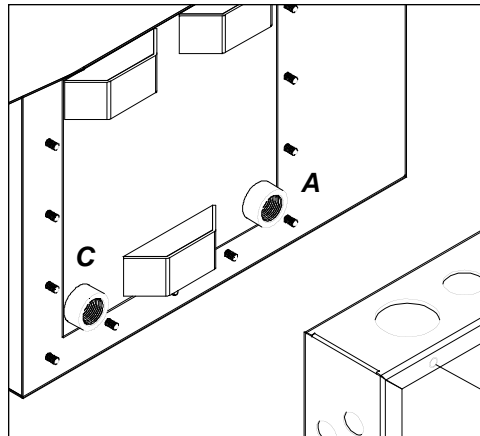

Gas Coil Weldment

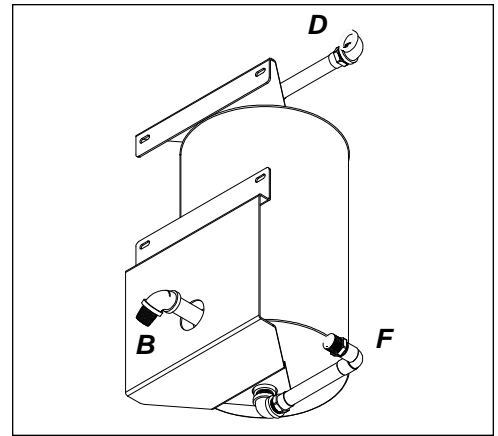

Rinse Booster Tank

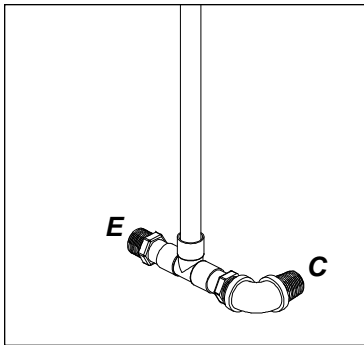

Rinse Header Plumbing Assembly

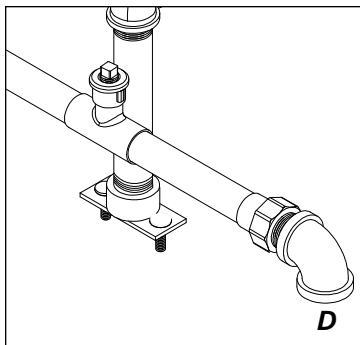

Wash/Fill Plumbing Assembly

HOSE ASSEMBLIES

AJ-44TG (L-R & R-L)

AJ-66TG (L-R)

AJ-66TG (R-L)

*Each hose assembly includes 2, 3/4" Pushlock Fittings (part number 04730-011-94-00).

A - Hose, Recirculating Discharge	(8 1/2") 05700-002-52-74	(18") 05700-002-51-38	(8 1/2") 05700-002-52-74
B - Hose, Recirculating Pump Suction	(18 1/2") 05700-002-52-75	(26") 05700-002-51-37	(18 1/2") 05700-002-52-75
C - Hose, Wash Coil Assembly	(34") 05700-002-52-76	(36") 05700-002-51-39	(50") 05700-002-57-58
D - Hose, Recirculating Discharge	(L-R 48") 05700-003-03-95 (R-L 60") 05700-003-03-97	(60") 05700-003-03-97	(60") 05700-003-03-97

E - Hose connection to existing gas booster outlet fitting.

F - Hose connection to existing gas booster inlet fitting.

Gas Booster Connection Kit 05700-002-51-73 includes:
18 Feet of 3/4" Hose
4 - 3/4" Push Lock Fittings

SECTION 5: PARTS SECTION
AJ-44T SERIES DRAIN PLUMBING ASSEMBLIES

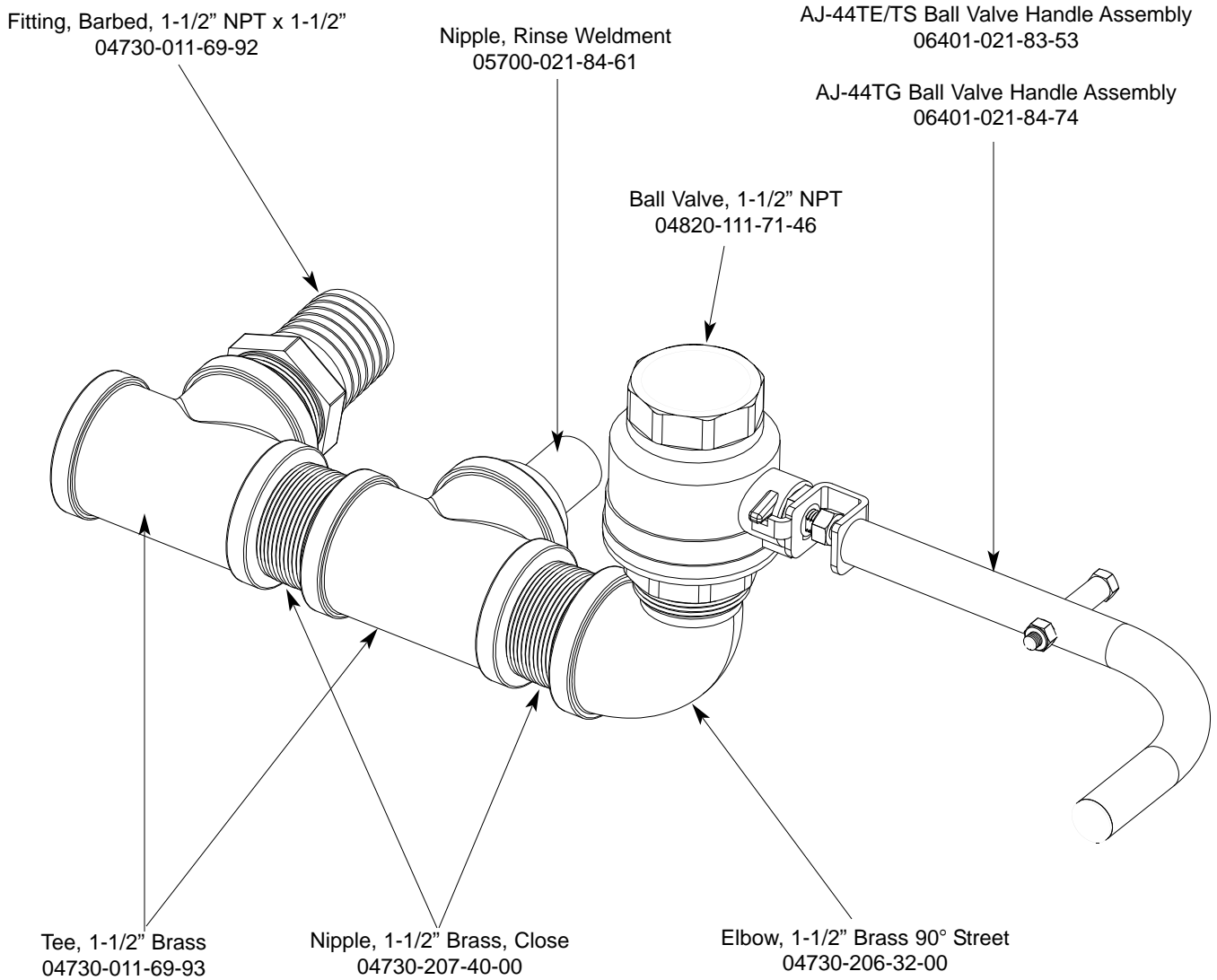

SECTION 5: PARTS SECTION
AJ-66T DRAIN PLUMBING ASSEMBLIES

Left to Right Plumbing Assembly

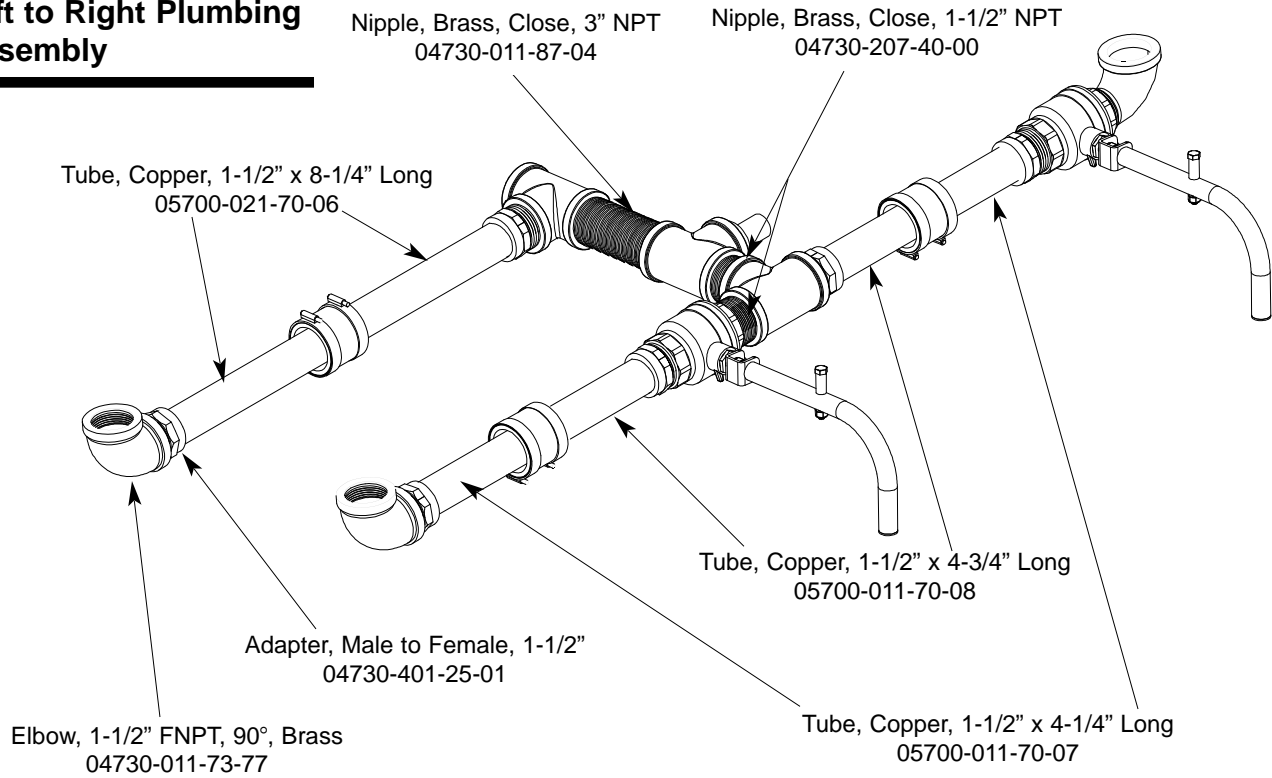

Right to Left Plumbing Assembly

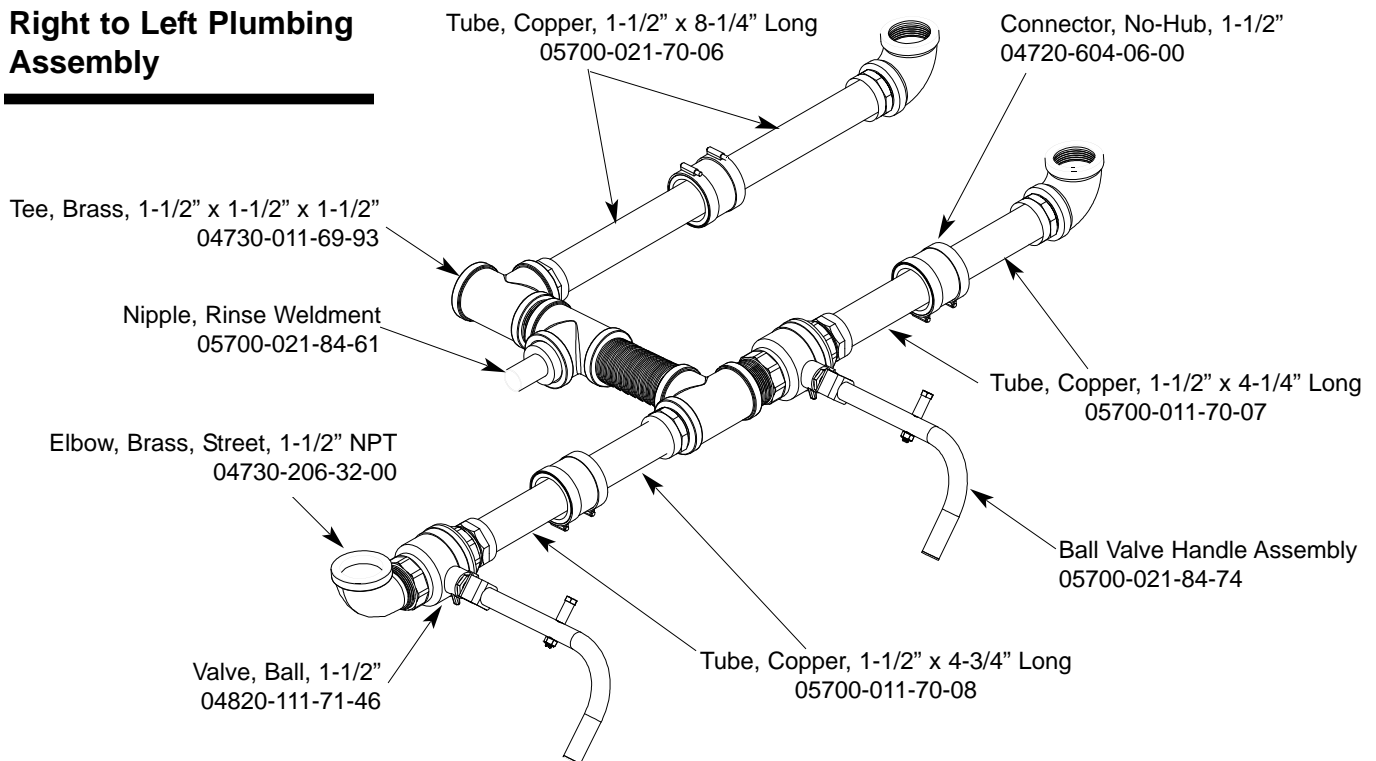

SECTION 5: PARTS SECTION
AJ-80T DRAIN PLUMBING ASSEMBLIES

Tube, Copper, 1-1/2" x 15-3/16" Long
 05700-002-06-99

Nipple, Brass, Close, 1-1/2" NPT
 04730-207-40-00

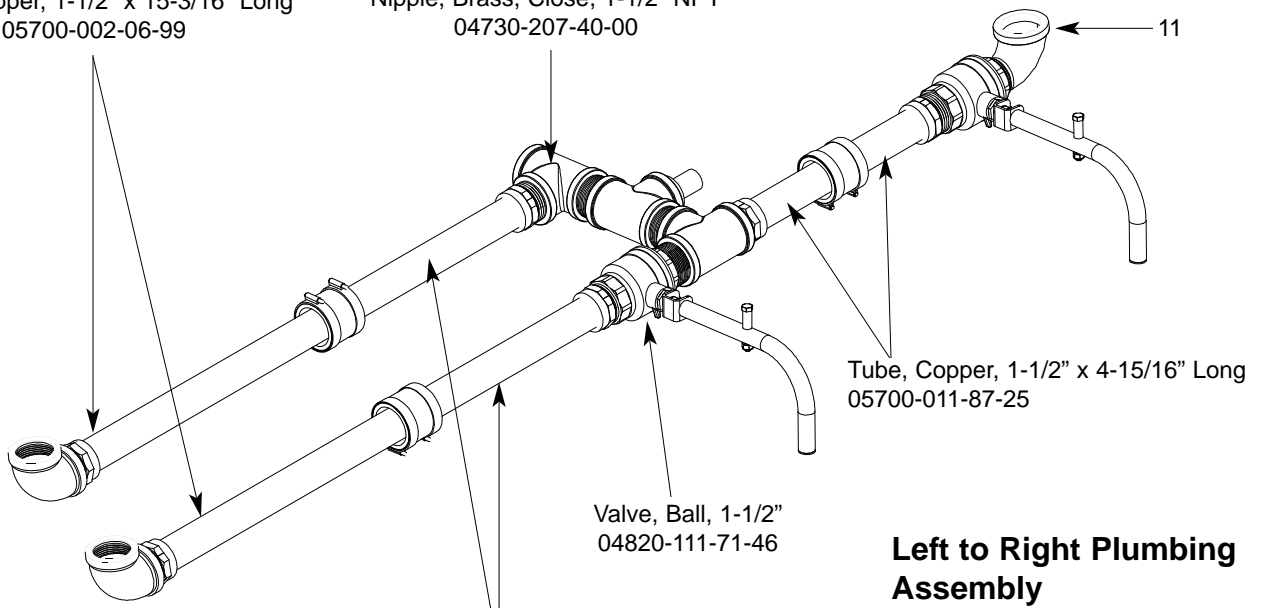

Tube, Copper, 1-1/2" x 4-15/16" Long
 05700-011-87-25

Valve, Ball, 1-1/2"
 04820-111-71-46

Left to Right Plumbing Assembly

Tube, Copper, 1-1/2" x 11-3/16" Long
 05700-002-07-00

Right to Left Plumbing Assembly

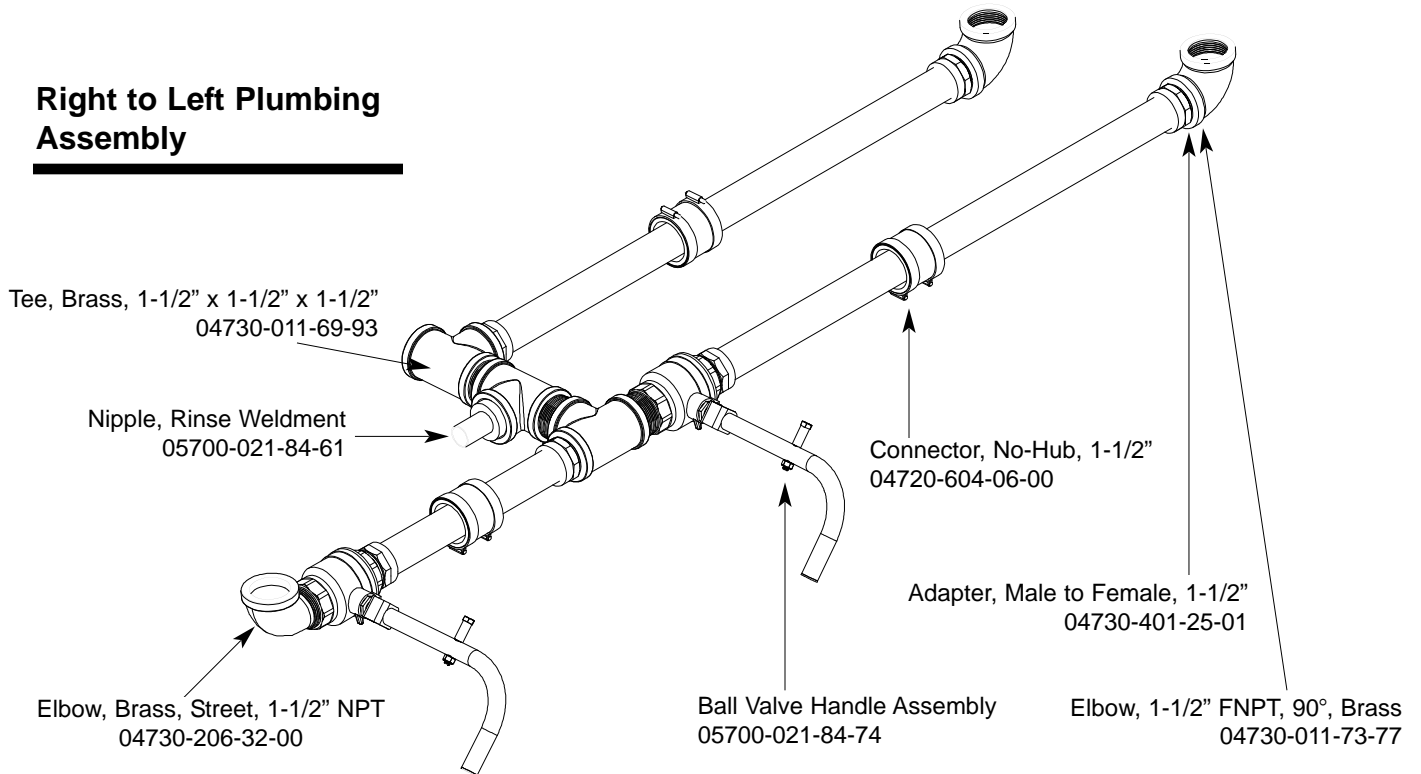

Tee, Brass, 1-1/2" x 1-1/2" x 1-1/2"
 04730-011-69-93

Nipple, Rinse Weldment
 05700-021-84-61

Connector, No-Hub, 1-1/2"
 04720-604-06-00

Adapter, Male to Female, 1-1/2"
 04730-401-25-01

Elbow, Brass, Street, 1-1/2" NPT
 04730-206-32-00

Ball Valve Handle Assembly
 05700-021-84-74

Elbow, 1-1/2" FNPT, 90°, Brass
 04730-011-73-77

SECTION 5: PARTS SECTION
AJ-66TG (LEFT TO RIGHT) DRAIN PLUMBING ASSEMBLY

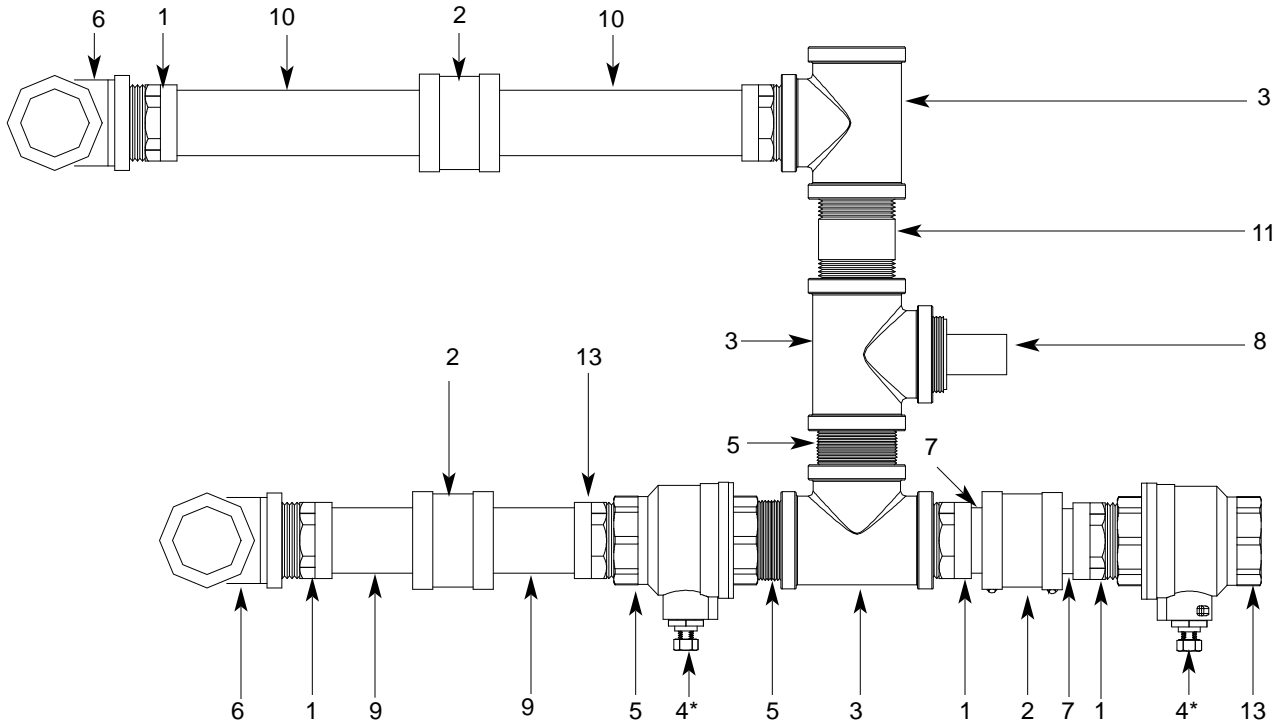

ITEM	QTY	DESCRIPTION	Mfg. No.
1	6	Adapter, Male to Female, 1-1/2"	04730-401-25-01
2	3	No-Hub Connector	04720-604-06-00
3	3	Tee, Brass, 1-1/2" FNPT	04730-011-69-93
4	2	Ball Valve, 1-1/2" FNPT	04820-011-71-46
*	2	Valve Handle Weldment Assembly (Not Shown)	06401-021-84-74
5	2	Nipple, Brass, Close, 1-1/2" NPT	04730-207-40-00
6	2	Elbow, Brass, 90°, 1-1/2" FNPT	04730-011-73-77
7	2	Tube, Copper, 1-1/2" x 1-3/4" Long	See Service Note
8	1	Rinse Nipple Weldment	05700-021-84-61
9	2	Tube, Copper, 1-1/2" x 3-1/2" Long	See Service Note
10	2	Tube, Copper, 1-1/2" x 7-1/2" Long	See Service Note
11	1	Nipple, Brass, 1-1/2" NPT x 3" Long	04730-011-87-04

Service Note: Copper tubing should be purchased locally and cut to length (lengths provided in parts list above).

SECTION 5: PARTS SECTION
AJ-66TG (RIGHT TO LEFT) DRAIN PLUMBING ASSEMBLY

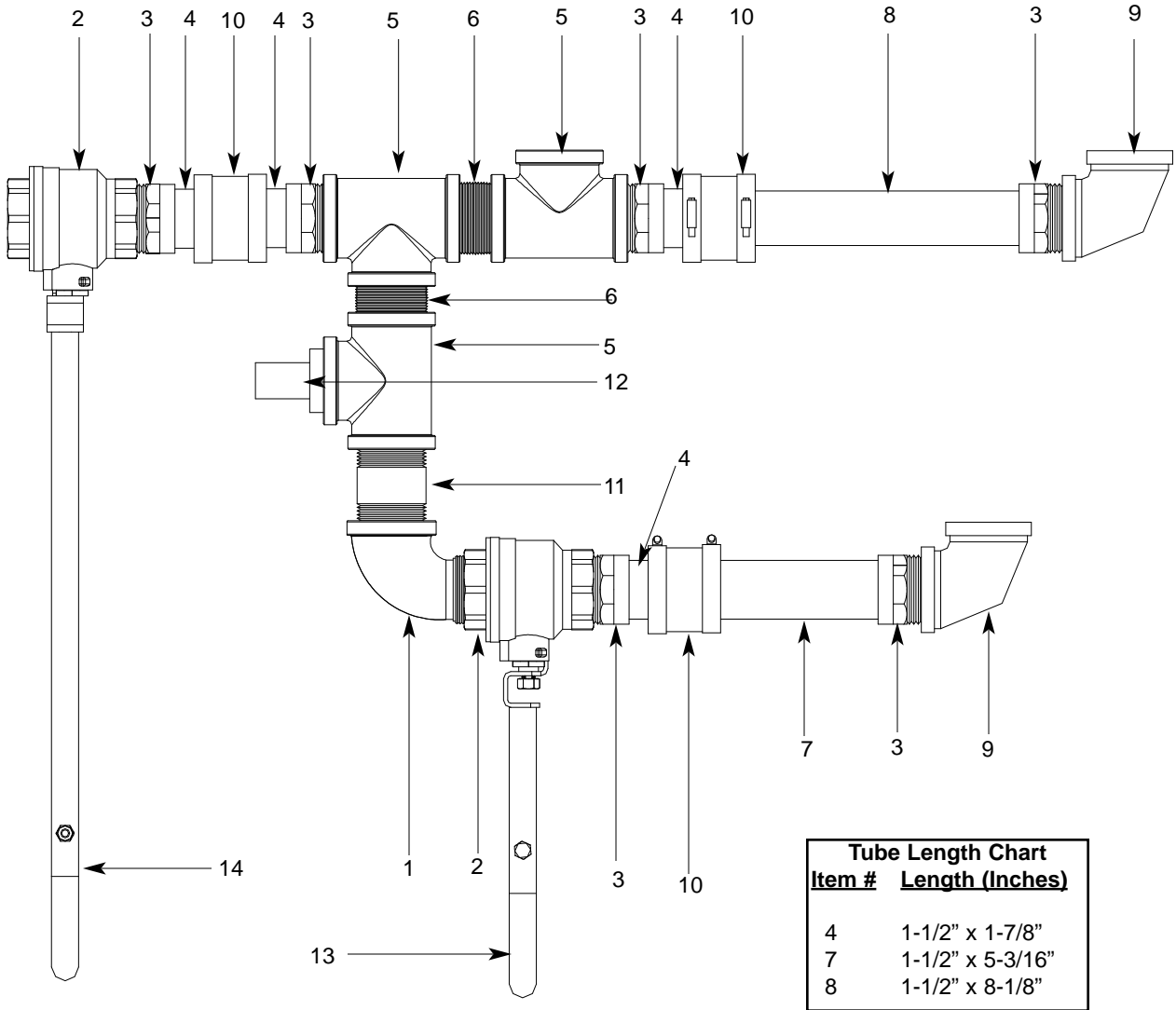

ITEM	QTY	DESCRIPTION	Mfg. No.
1	1	Elbow, 1-1/2" NPT, Brass, Street	04730-206-32-00
2	2	Valve, Ball, 1-1/2" FNPT	04820-011-71-46
3	6	Adapter, Male to Female, 1-1/2"	04730-401-25-01
4	4	Tube, Copper	See Chart
5	3	Tee, Brass, 1-1/2" FNPT	04730-011-69-93
6	2	Nipple, Brass, 1-1/2" NPT, Close	04730-207-40-00
7	2	Tube, Copper	See Chart
8	2	Tube, Copper	See Chart
9	2	Elbow, Brass, 90°, 1-1/2" FNPT	04730-011-73-77
10	3	No-Hub Connector	04720-604-06-00
11	1	Nipple, Brass, 1-1/2" NPT x 3" Long	04730-011-87-04
12	1	Rinse Nipple Weldment	05700-021-84-61
13	1	Valve Handle Weldment Assembly	06401-021-84-74
14	1	Valve Handle Weldment Assembly	06401-002-57-83

SECTION 5: PARTS SECTION

DRAIN QUENCH SYSTEM

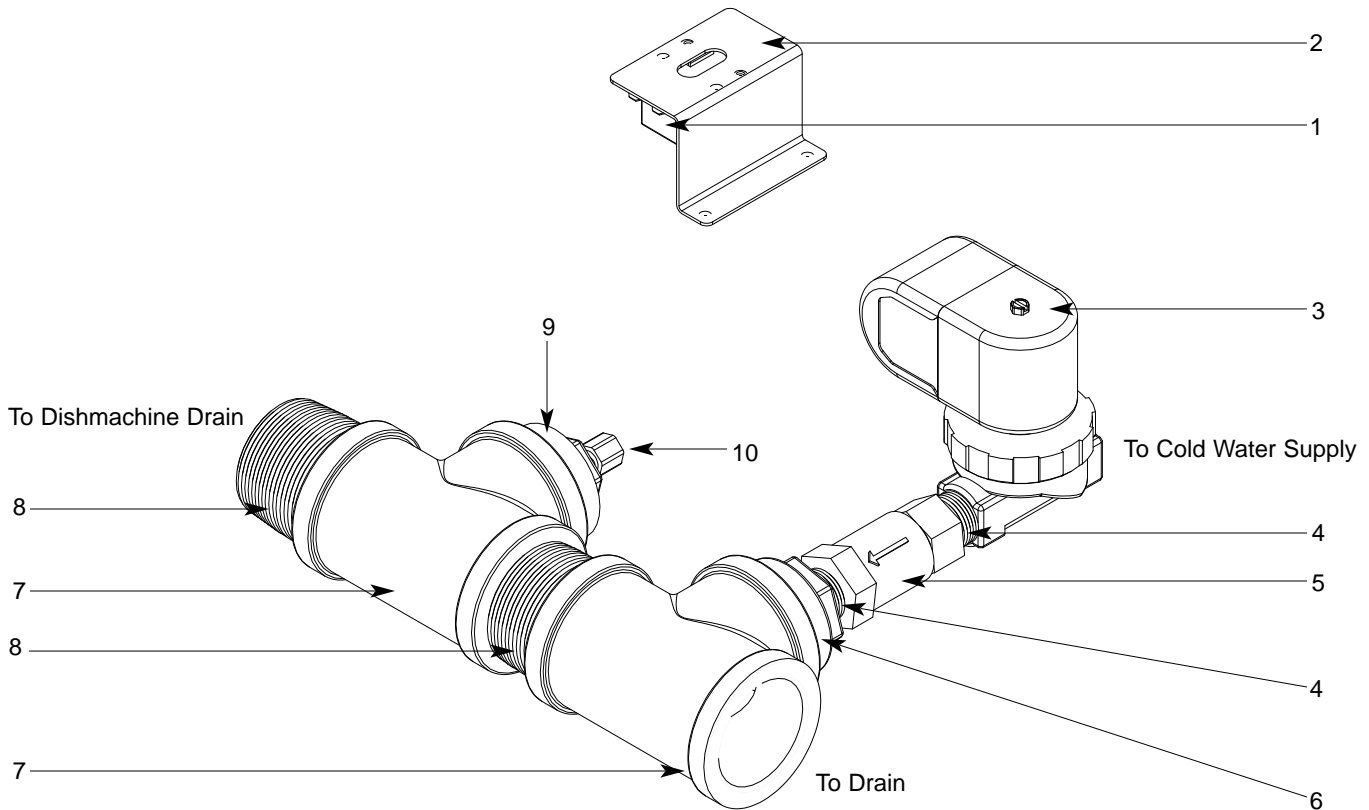

From the existing drain, attach the two additional Tees (Item 7) using the 1-1/2" NPT Close Nipples (Item 8). Tighten the Reducers (Items 6 & 9) into the Tees as shown above. Attach the Modified Compression Fitting (Item 10) into the 1-1/2" to 1/4" Reducer (Item 9). Position the bulb of the thermostat (Item 1) so that it rests approximately 1/4" from the bottom of the Tee (Item 7). Tighten the Modified Compression Fitting (Item 10) as required.

Mount the Thermostat (Item 1) to the tub using the Thermostat Bracket (Item 2) and set it for 120°F - 140°F. Install the Solenoid Valve (Item 3) to the second Tee (Item 7) and then attach to the incoming cold water line. Use pipe dope or thread tape as required to prevent any leaks.

ITEM	QTY	DESCRIPTION	Mfg. No.
1	1	Thermostat	05930-121-67-72
2	1	Thermostat Bracket	05700-011-81-64
3	1	Solenoid Valve	04810-100-09-18
4	2	Nipple, Close, 1/2" NPT, Brass	04730-207-15-00
5	1	Valve, Check, 1/2"	04820-002-55-77
6	1	Reducer, 1-1/2" to 1/2"	04730-002-55-75
7	2	Tee, 1-1/2" x 1-1/2" x 1-1/2"	04730-011-69-93
8	2	Nipple, 1-1/2", Close, Brass	04730-207-40-00
9	1	Reducer, 1-1/2" to 1/4"	04730-002-55-76
10	1	Modified Compression Fitting	05700-001-16-52
	1	Complete Kit	06401-002-44-07

SECTION 5: PARTS SECTION

MOTOR ASSEMBLIES

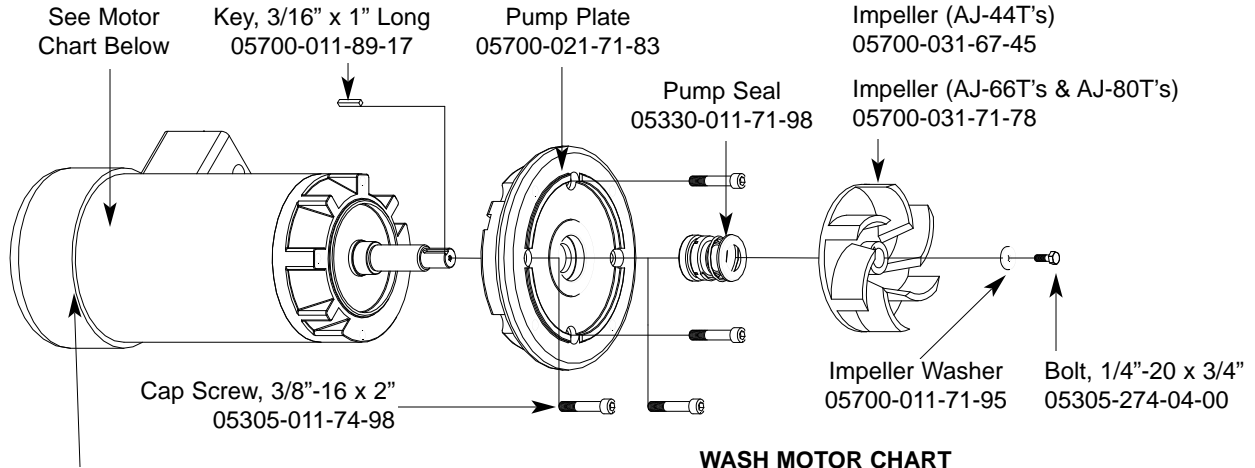

WASH MOTOR CHART

Motor Mounting Clamp, 4 1/8" - 7"
(Not Shown)
04730-002-32-15

Volts	Phase	Hz	Part Number	Kit Part Number
200 - 440	3	50	06105-121-81-34	06401-003-09-96
208 - 230	1	60	06105-021-70-57	06401-003-09-97
200 - 230	3	60	06105-121-70-58	06401-003-09-98
380	3	60	06105-121-81-34	06401-003-09-96
460	3	60	06105-121-70-58	06401-003-09-98
600	3	60	06105-002-48-31	06401-003-09-99

Complete Assembly
05700-021-73-42

PREWASH MOTOR CHART

Upper Support Bracket
05700-021-73-68

Model(s)	Volts	Phase	Hz	Part Number	Kit Part Number
AJ-66T's	208-230	3	50	06105-121-70-56	06401-003-10-38
	380	3	50	06105-121-81-34	06401-003-10-39
	415	3	50	06105-121-81-34	06401-003-10-39
	440	3	50	06105-121-70-56	06401-003-10-38
	208-230	1	60	06105-121-70-55	06401-003-10-40
	200-230	3	60	06105-121-70-56	06401-003-10-38
AJ-80T's	380	3	60	06105-121-70-56	06401-003-10-38
	460	3	60	06105-121-70-56	06401-003-10-38
	600	3	60	06105-002-48-31	06401-003-10-41
	208-230	3	50	06105-121-81-34	06401-003-10-39
	380	3	50	06105-121-81-34	06401-003-10-39
	415	3	50	06105-121-81-34	06401-003-10-39
	440	3	50	06105-121-81-34	06401-003-10-39
	208-230	1	60	06105-121-70-57	06401-003-10-42
	200-230	3	60	06105-121-70-58	06401-003-10-43
	380	3	60	06105-121-81-34	06401-003-10-39

Nut, 1/4"-20 Serrated
05310-011-66-49

Lower Support Bracket
05700-021-73-71

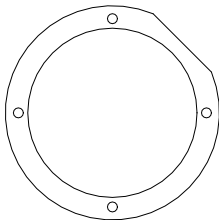

Motor Mounting Gasket
05330-011-71-62

SECTION 5: PARTS SECTION
PREWASH & WASH PUMP WELDMENTS

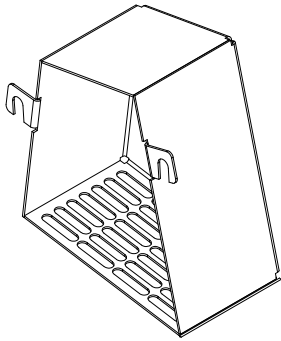

Intake Suction Scoop Weldment
 05700-021-87-60

Prewash Intake
 Strainer Weldment
 05700-021-74-96

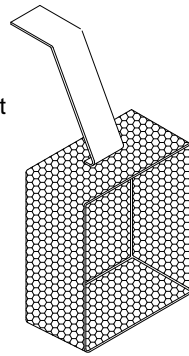

Wash Pump
 Weldment
 05700-041-68-88

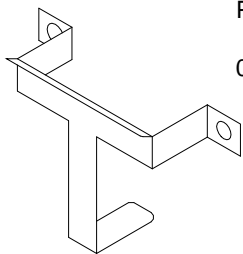
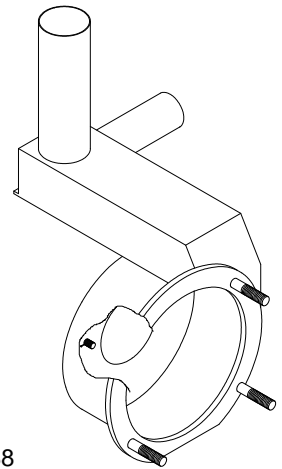

Prewash Strainer
 Bracket
 05700-021-74-94

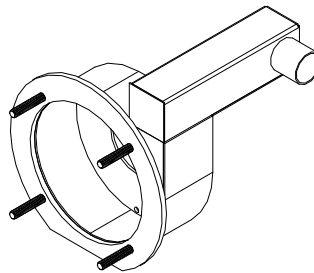

Prewash Pump Weldment
 AJ-66/AJ-80 Left to Right models:
 05700-002-10-62

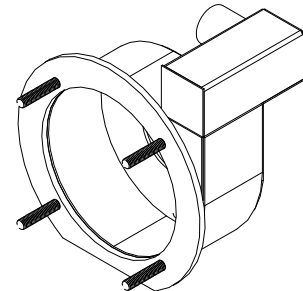

Prewash Pump Weldment
 AJ-66/AJ-80 Right to Left models:
 05700-002-11-96

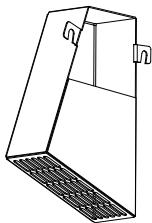

Scoop, Intake Suction Wash
 Weldment
 05700-002-51-20

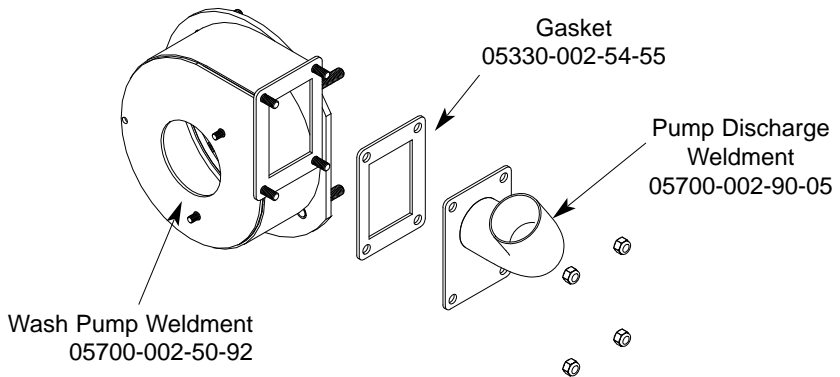

Wash Pump Weldment
 05700-002-50-92

Gasket
 05330-002-54-55

Pump Discharge
 Weldment
 05700-002-90-05

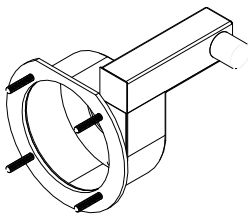

Prewash Pump Weldment
 AJ-66TG Left to Right model
 05700-002-43-56

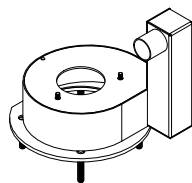

Prewash Pump Weldment
 AJ-66TG Right to Left model
 05700-002-42-69

SECTION 5: PARTS SECTION

PREWASH ARM/MANIFOLD ASSEMBLY (AJ-66T & AJ-80T MODELS ONLY)

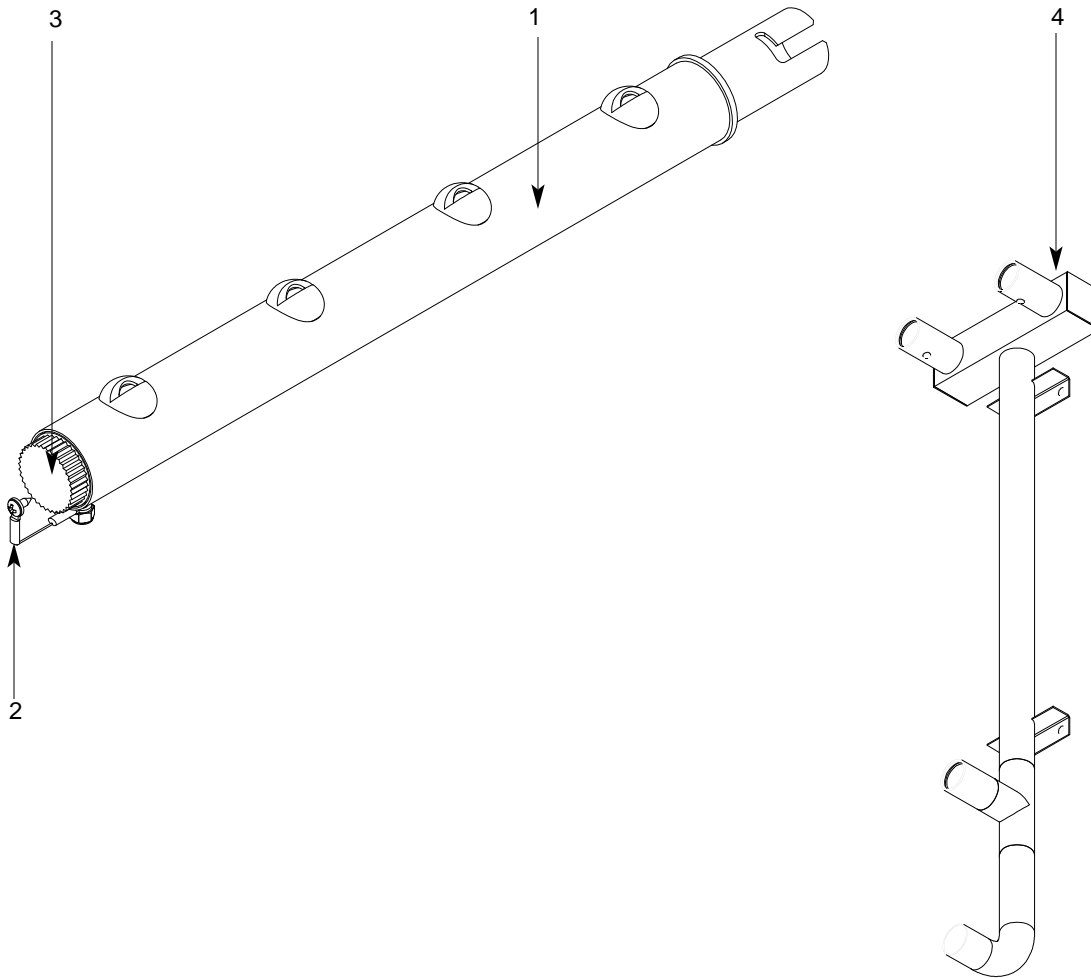

SERVICE NOTE: When replacing the 10-32 screws in the End Caps, it is recommended that a thread locking fluid be used to ensure that the screws do not back out during normal operation.

ITEM	QTY	DESCRIPTION	Mfg. No.
1	1	Wash Arm Weldment	05700-002-95-25
2	1	Lanyard	05340-011-72-46
3	1	Cap, Threaded	04730-603-12-00
		Items 1 through 3 + Hardware	05700-002-95-19
	1	O-ring (Not Shown)	05330-400-12-08
4	1	Prewash Manifold Weldment	05700-003-01-66

SECTION 5: PARTS SECTION
WASH ARM/MANIFOLD ASSEMBLY

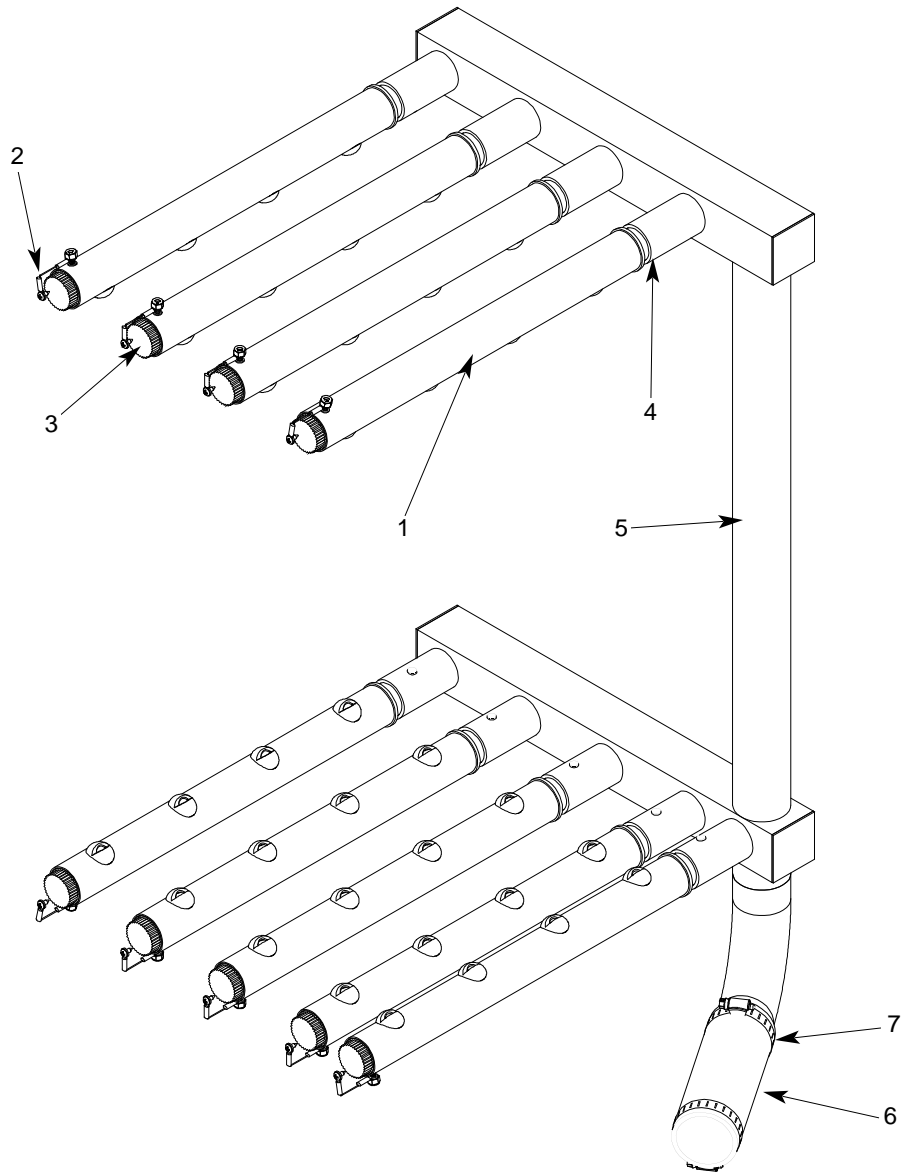

ITEM	QTY	DESCRIPTION	Mfg. No.
	9	Wash Arm Assembly	05700-002-95-19
	9	Screw, 10-32 x 3/8" Long Phillips Truss Head	05305-173-12-00
	9	Locknut, 10-24 S/S Hex with Nylon Insert	05310-373-01-00
1	9	Wash Arm Weldment	05700-002-95-25
2	9	Lanyard	05340-011-72-46
3	9	End Cap, Wash Tube	05700-011-67-11
4	9	O-ring	05330-400-12-08
5	1	Wash Manifold Weldment Left to Right	05700-002-95-20
		Right to Left	05700-002-95-66
6	1	Hose, 2" X 6.75" Manifold Pump	05700-002-90-79
7	2	Clamp, Hose 1-9/16" TO 2-1/2"	04730-011-34-89

SECTION 5: PARTS SECTION

FINAL RINSE ASSEMBLY

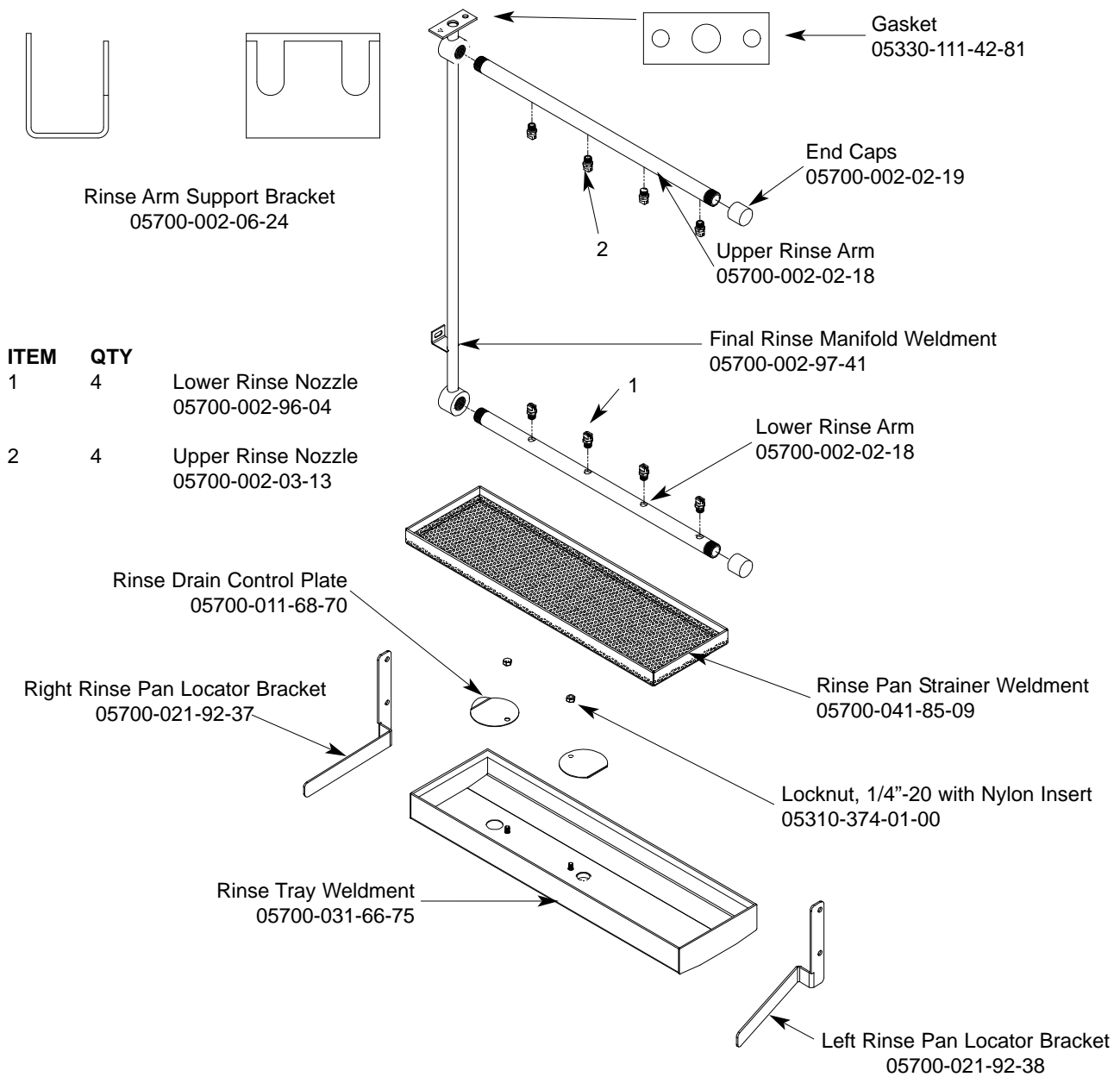

ITEM	QTY	Description
1	4	Lower Rinse Nozzle 05700-002-96-04
2	4	Upper Rinse Nozzle 05700-002-03-13

Optional Parts for TG Models

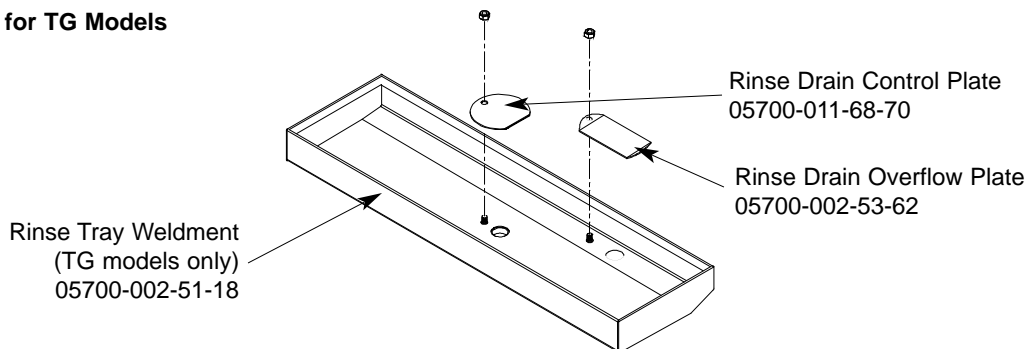

SECTION 5: PARTS SECTION
DRIVE ASSEMBLY

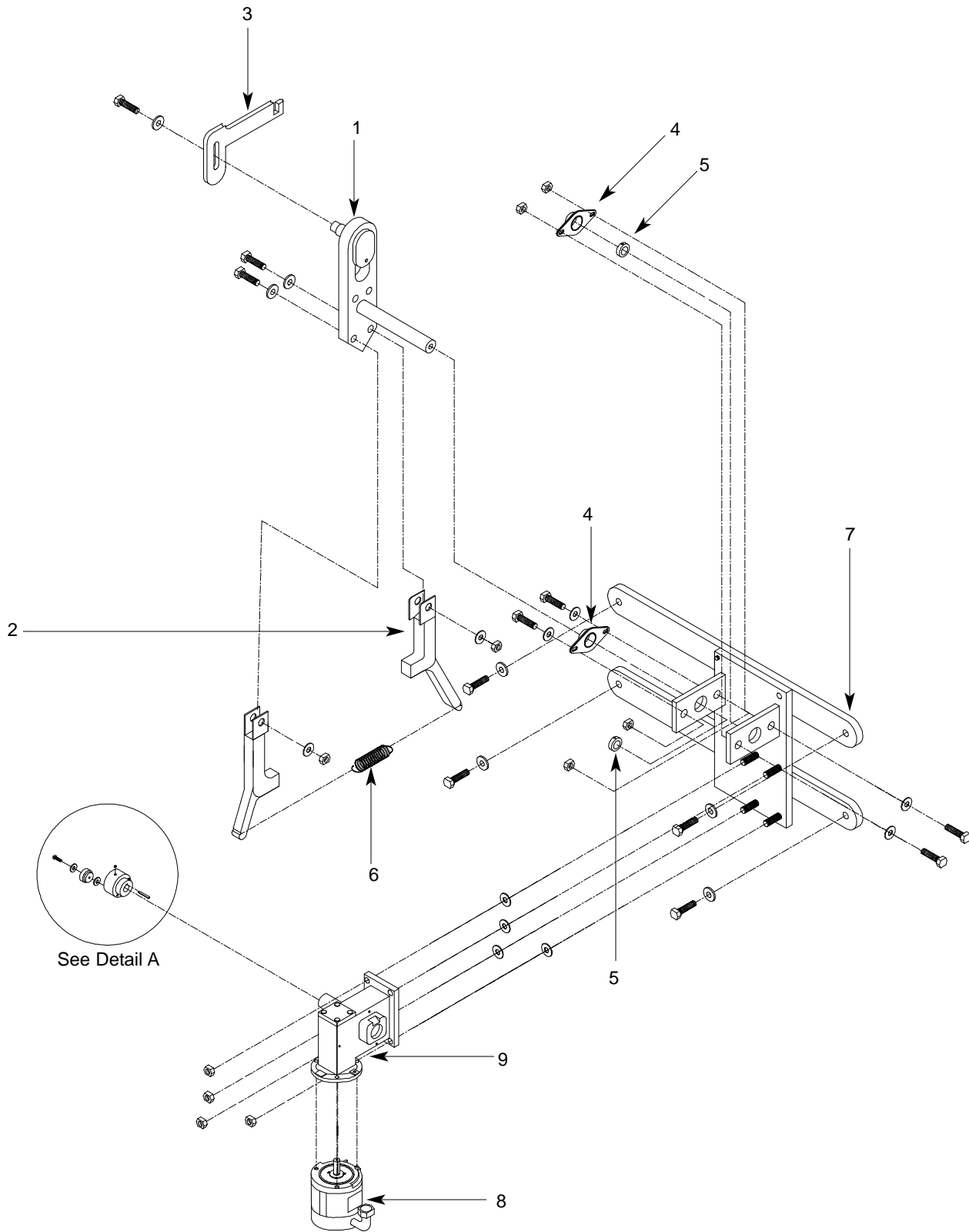

SECTION 5: PARTS SECTION

DRIVE ASSEMBLY (CONTINUED)

ITEM	QTY	DESCRIPTION	Mfg. No.
1	1	Drive Plate and Rod Weldment	05700-003-06-84
2	2	Coupling & Expansion Leg Weldment	09515-003-58-12
3	1	Pawl Bar Drive Linkage Casting	09515-021-87-73
4	2	Pillow Block	06401-003-08-50
5	2	Shaft Collar	05700-011-89-18
6	1	Drive Spring	05315-011-83-51
7	1	Drive Motor Mounting Bracket	05700-031-73-56
8	1	Drive Motor (50 Hz Models)	06401-003-08-41
	1	Drive Motor (208-230 Volt, 60 Hz, Single Phase)	06401-003-08-42
		Drive Motor (208-230 Volt, 60 Hz, Three Phase Models)	06401-003-08-40
		Drive Motor (460 Volt, 60 Hz, Three Phase Models)	06401-003-08-43
		Drive Motor (600 Volt, 60 Hz, Three Phase Models)	06401-002-48-32
9	1	Gear Drive	06105-011-71-88
10	1	Roller Bearing	03120-011-71-81
11	1	Drive Hub	05700-011-67-97
*		Complete Drive Assembly	05700-003-06-83

Decal, Drive Adjuster
09905-021-72-24

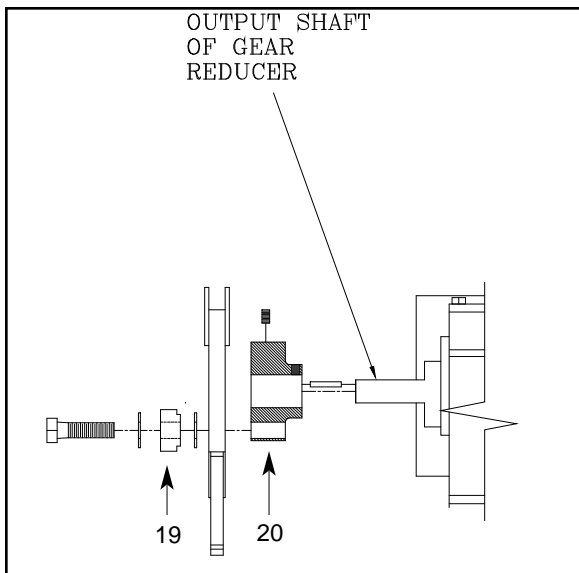

Detail A

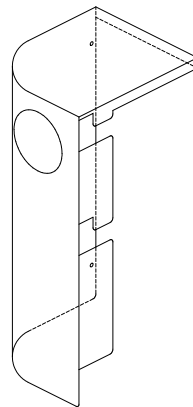

Front Drive Motor Cover
Replacement Kit
06401-003-11-64

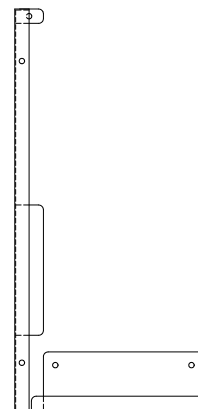

Rear Drive Motor Cover
Replacment Kit
06401-003-10-18

Replacement Kits Notes:

The replacement kits for the drive motor covers come with the weldments and the mounting hardware.

SECTION 5: PARTS SECTION
DOOR ASSEMBLIES

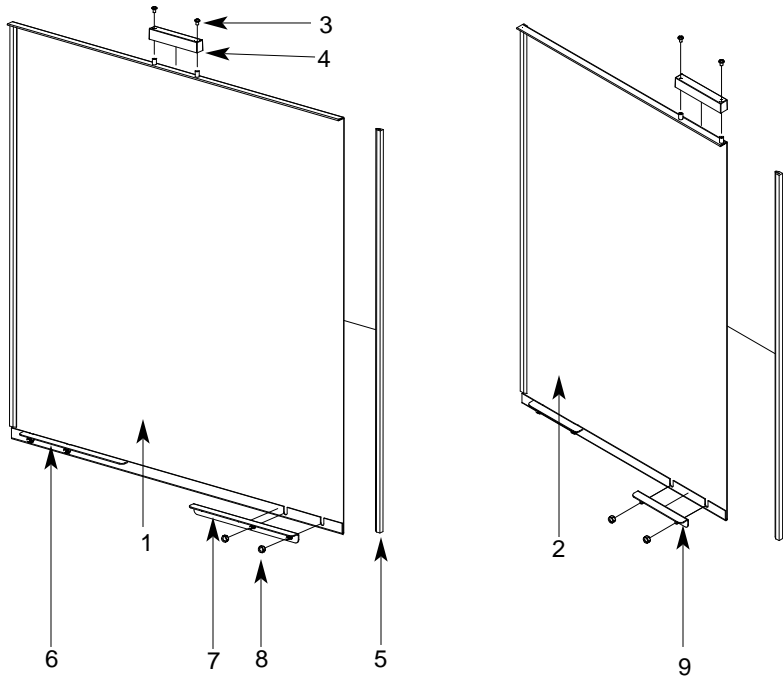

Locknut, 1/4"-20 with Nylon Insert
05310-374-01-00

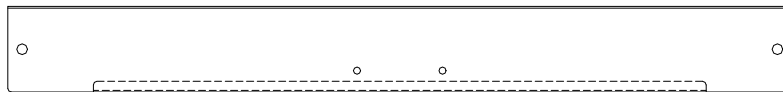

Wash Door Hood Support: 05700-031-84-13
22" Prewash Door Hood Support: 05700-031-84-14

Door Stiffener (Not Shown) 05700-031-83-43

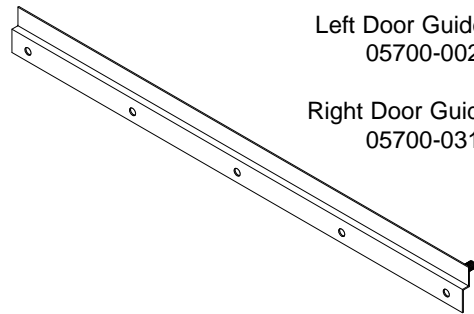

Left Door Guide Weldment
05700-002-32-51

Right Door Guide Weldment
05700-031-76-44

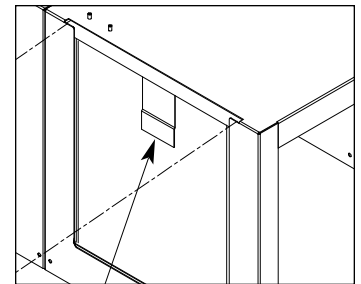

Door Catch Weldment
05700-031-84-80

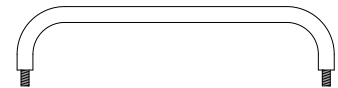

Wash Door Handle Weldment
05700-011-82-63

Prewash Door Handle Weldment
05700-011-80-45

ITEM	QTY	DESCRIPTION	Mfg. No.
1	1	Wash Door Weldment	05700-003-13-47
2	1	Prewash Door Weldment (AJ-66 & AJ-80's) Left to Right Model Right to Left Model	05700-003-13-43 05700-003-13-40
3	1	Screw, 8-32 x 1/4" Long	05305-172-09-00
4	1	Door Switch Magnet	05700-111-51-68
5	1	Door Guide	05700-111-70-92
6	1	Bracket, Right Door Stop Weldment	05700-002-96-33
7	1	Bracket, Left Door Stop Weldment	05700-002-96-32
8	4	Locknut, 10-24 SS Hex with Nylon Insert	05310-373-01-00
9	2	Bracket, Pre Wash Door Stop	05700-002-05-46

SECTION 5: PARTS SECTION

PAWL BAR ROLLER BRACKET

Pawl Bar Roller Replacement Kit
06401-003-11-80

Replacement Kit Notes:

The replacement kit for the pawl bar roller comes with the roller, roller shaft, hardware and locknut as shown.

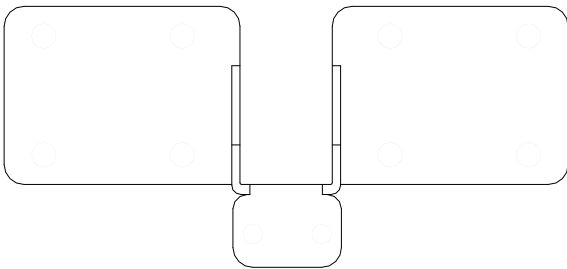
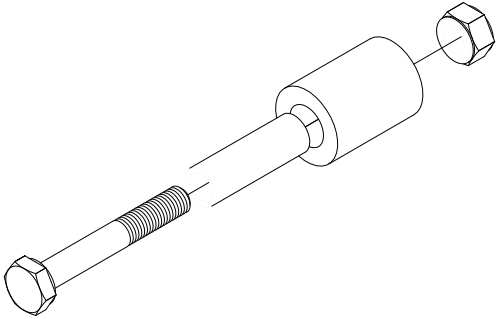

Pawl Bar Bracket (without tabs) Weldment
05700-031-92-36

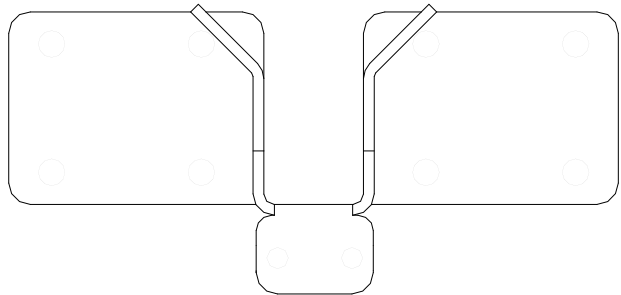

Pawl Bar Bracket (with studs) Weldment
05700-031-84-68

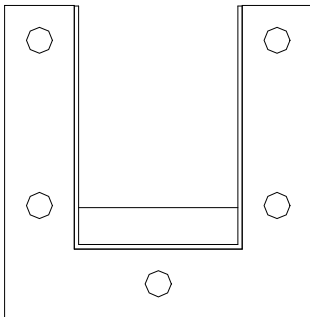

Pawl Bar Gutter Weldment Replacement Kit
06401-003-09-95

Replacement Kits Notes:

The pawl bar gutter weldment replacement kit contains the weldment, a gasket and the mounting hardware. The guide block kit contains both blocks and a gasket.

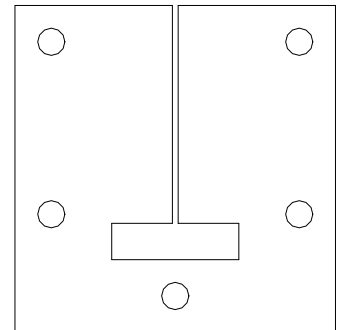

Pawl Bar Gutter Gasket
05330-011-68-55

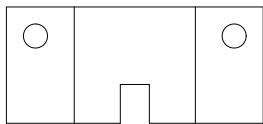

Top Guide Block

Guide Block Replacment Kit
06401-003-10-15

Bottom Guide Block

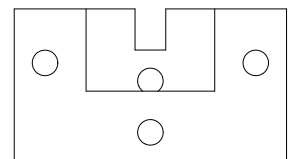

Service Note: It is highly recommended that when changing out one guide block, that the other be changed out as well, along with the gasket.

SECTION 5: PARTS SECTION
AJ-44T & AJ-66T PAWL BAR ASSEMBLIES

Pawl Bar Dog Casting
 12 per
 05700-021-69-00

AJ-44T Complete Assembly with Hardware
 06401-131-81-00

AJ-44T Prison Assembly with Hardware
 06401-231-81-00

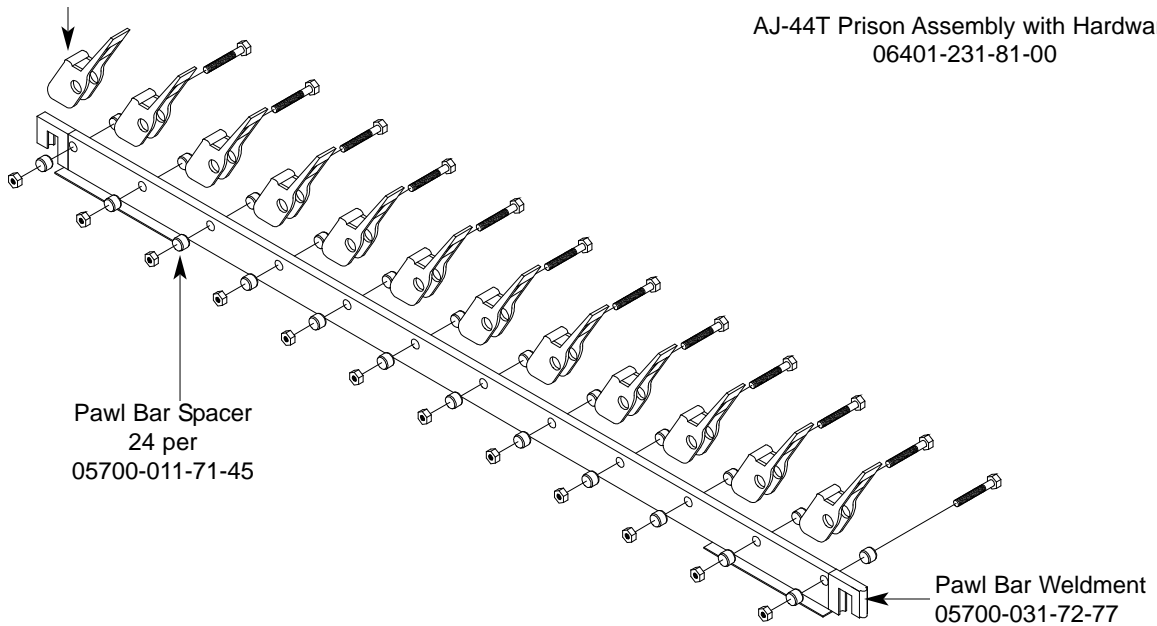

Pawl Bar Spacer
 24 per
 05700-011-71-45

Pawl Bar Weldment
 05700-031-72-77

AJ-66T Complete Assembly with Hardware
 06401-141-74-64

AJ-66T Prison Assembly with Hardware
 06401-241-74-64

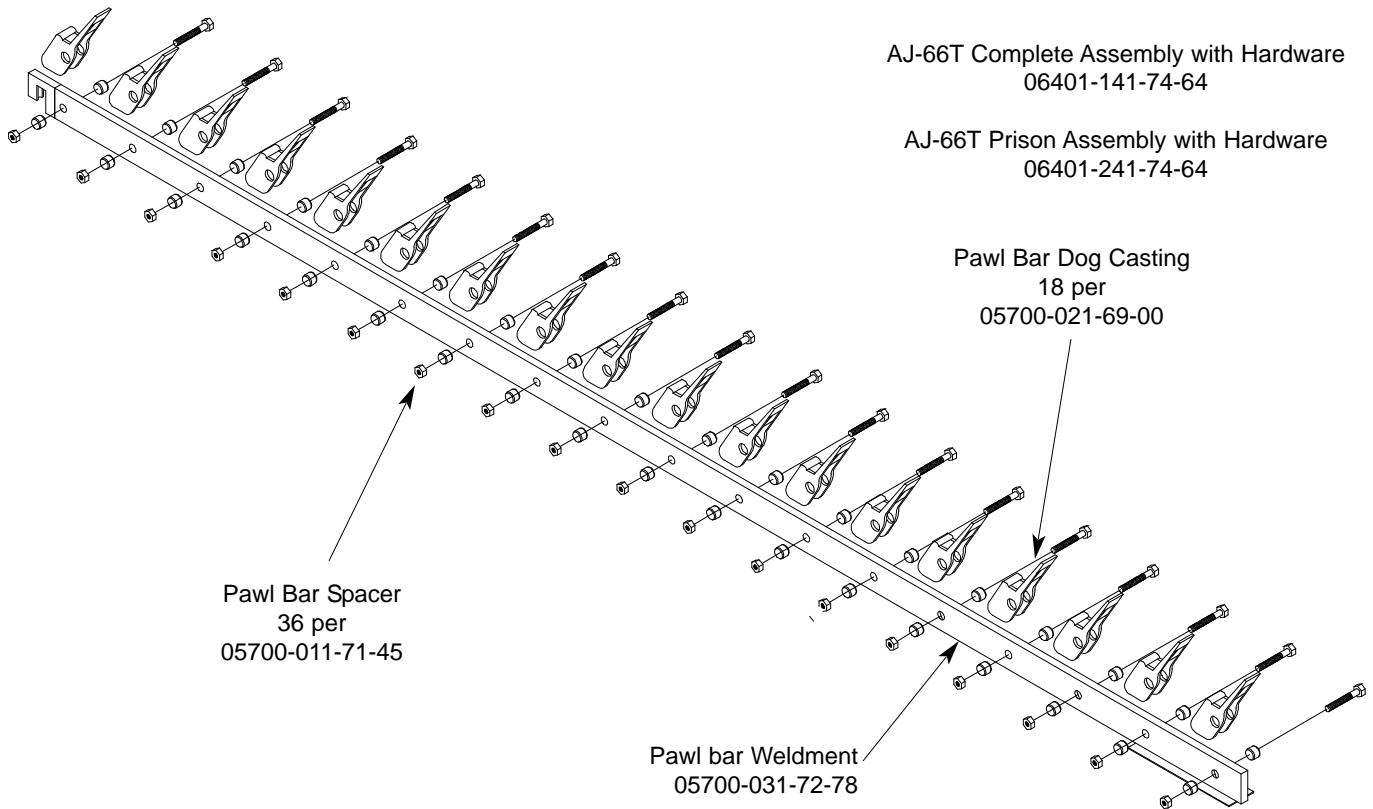

Pawl Bar Dog Casting
 18 per
 05700-021-69-00

Pawl Bar Spacer
 36 per
 05700-011-71-45

Pawl bar Weldment
 05700-031-72-78

SECTION 5: PARTS SECTION

AJ-80T PAWL BAR ASSEMBLIES

Left to Right Assembly (06401-141-81-06)

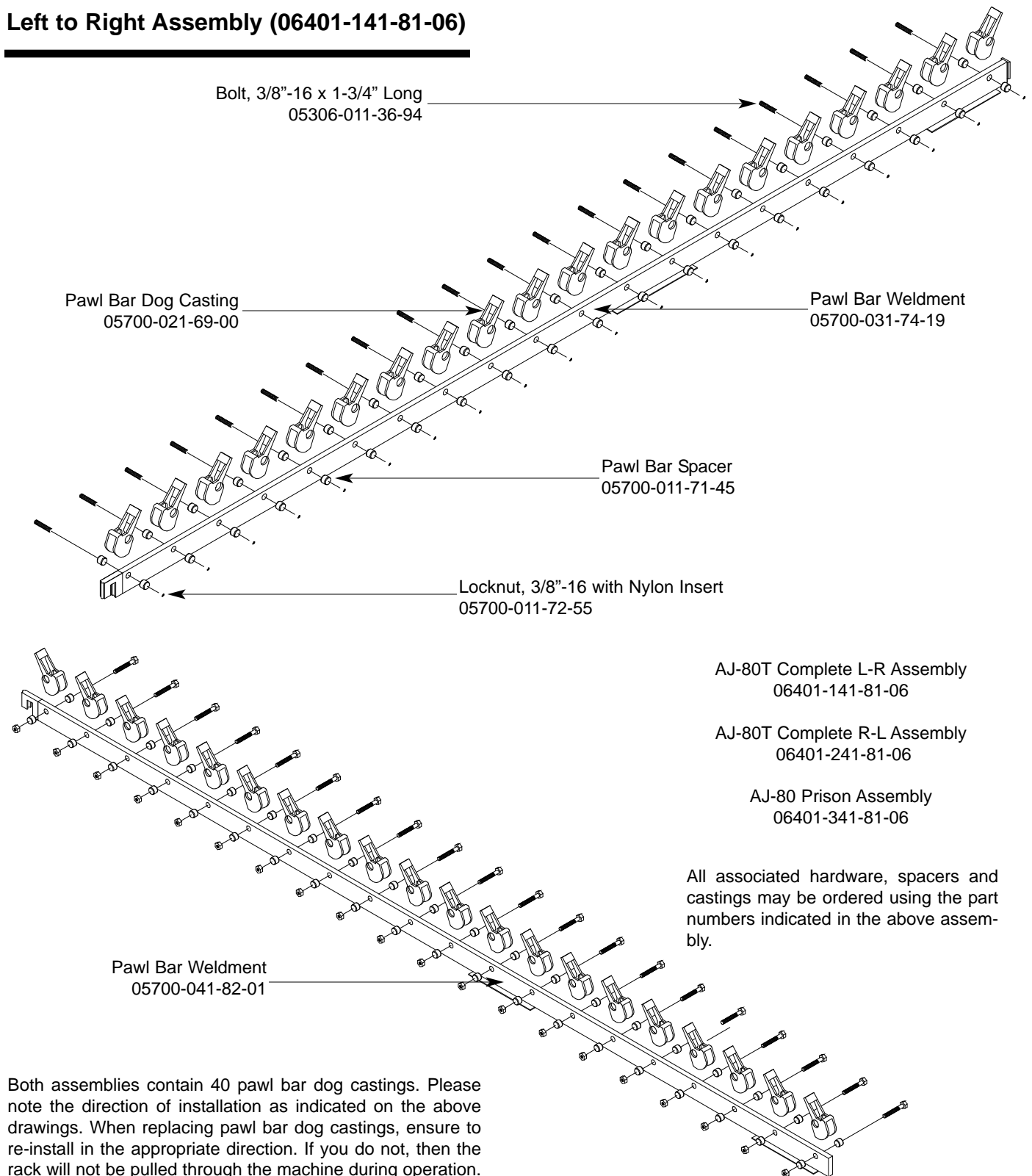

SECTION 5: PARTS SECTION

AJ-44T RACK RAIL ASSEMBLY

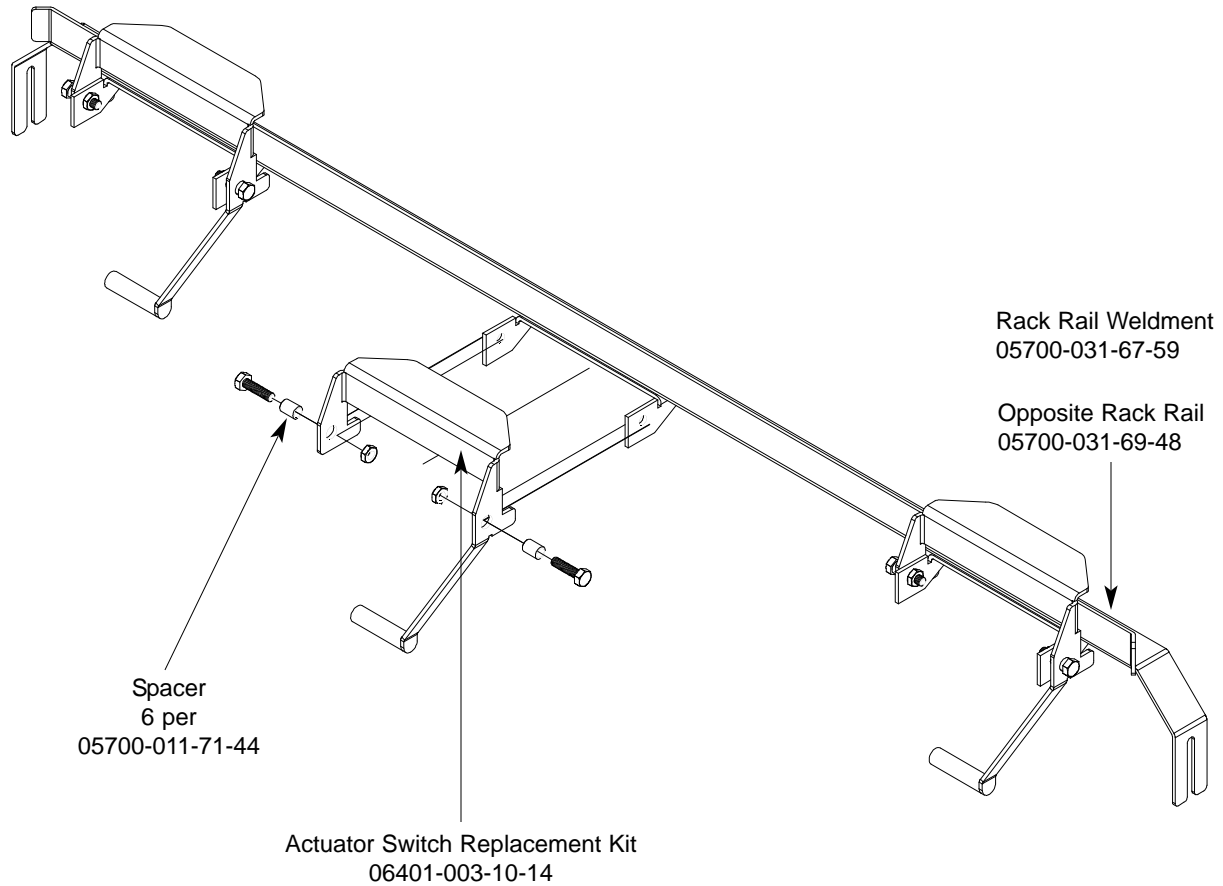

Replacement Kit Note:

The replacement kit for the actuator switch comes with the switch, two spacers and the mounting hardware.

SECTION 5: PARTS SECTION

AJ-66T RACK RAIL ASSEMBLIES

Left to Right Assembly

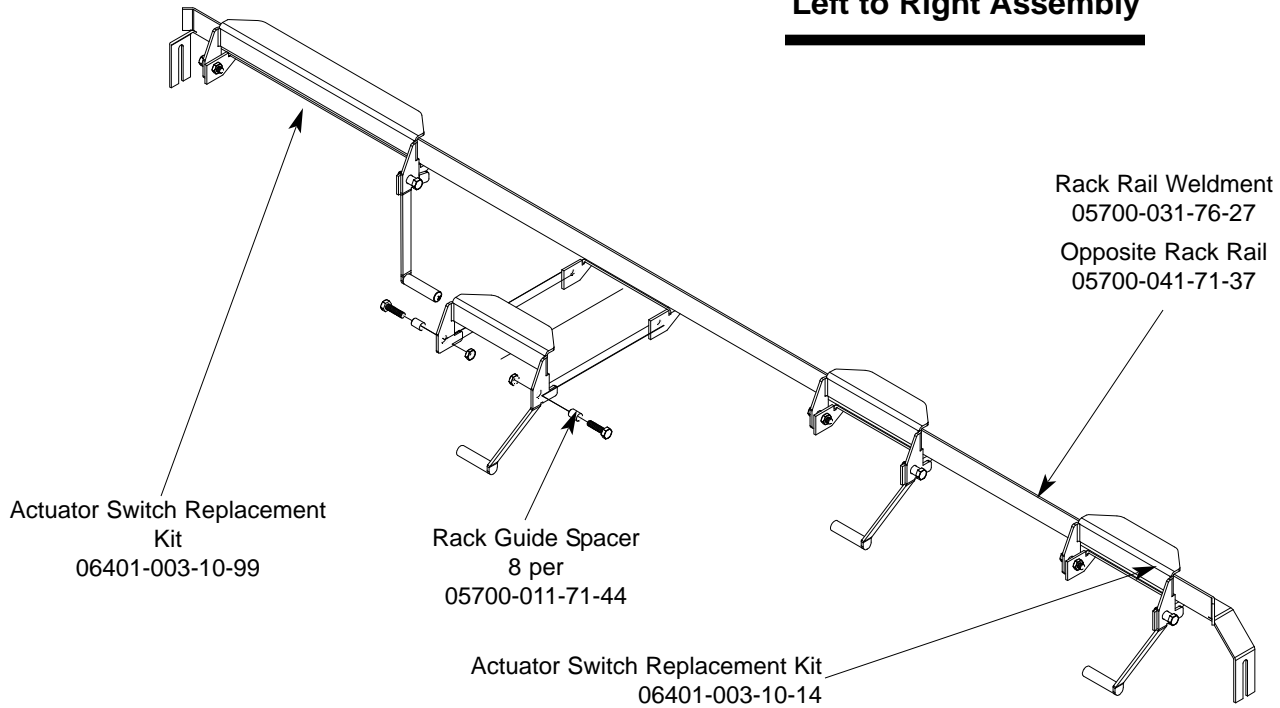

Right to Left Assembly

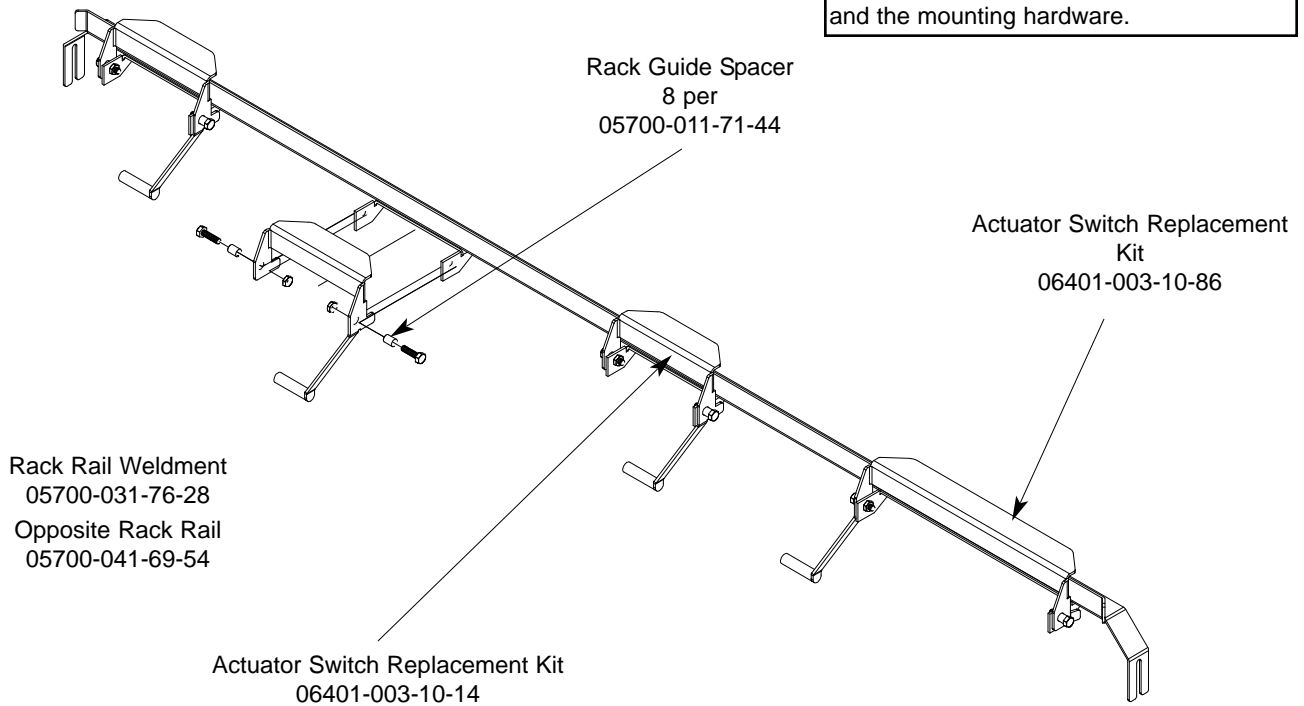

Replacement Kit Notes:
The replacement kits for the actuator switches come with the switch, two spacers and the mounting hardware.

SECTION 5: PARTS SECTION

AJ-80T RACK RAIL ASSEMBLIES

Left to Right Assembly

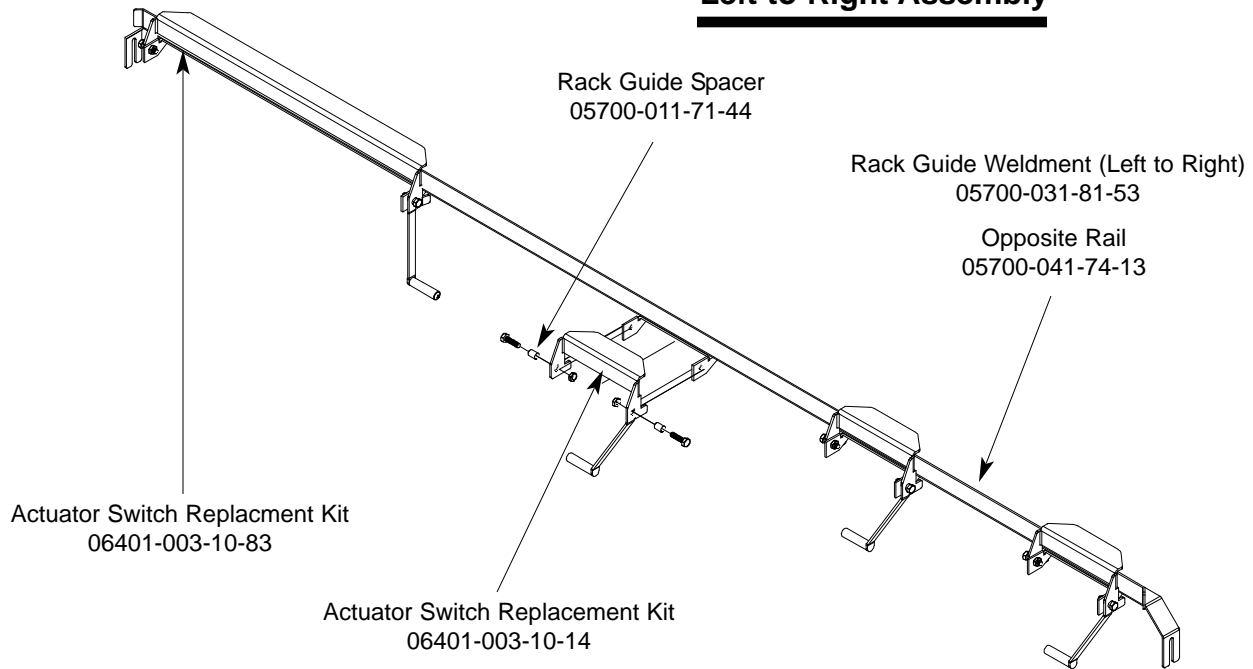

Right to Left Assembly

Replacement Kit Notes:

The replacement kits for the actuator switches come with the switch, two spacers and the mounting hardware.

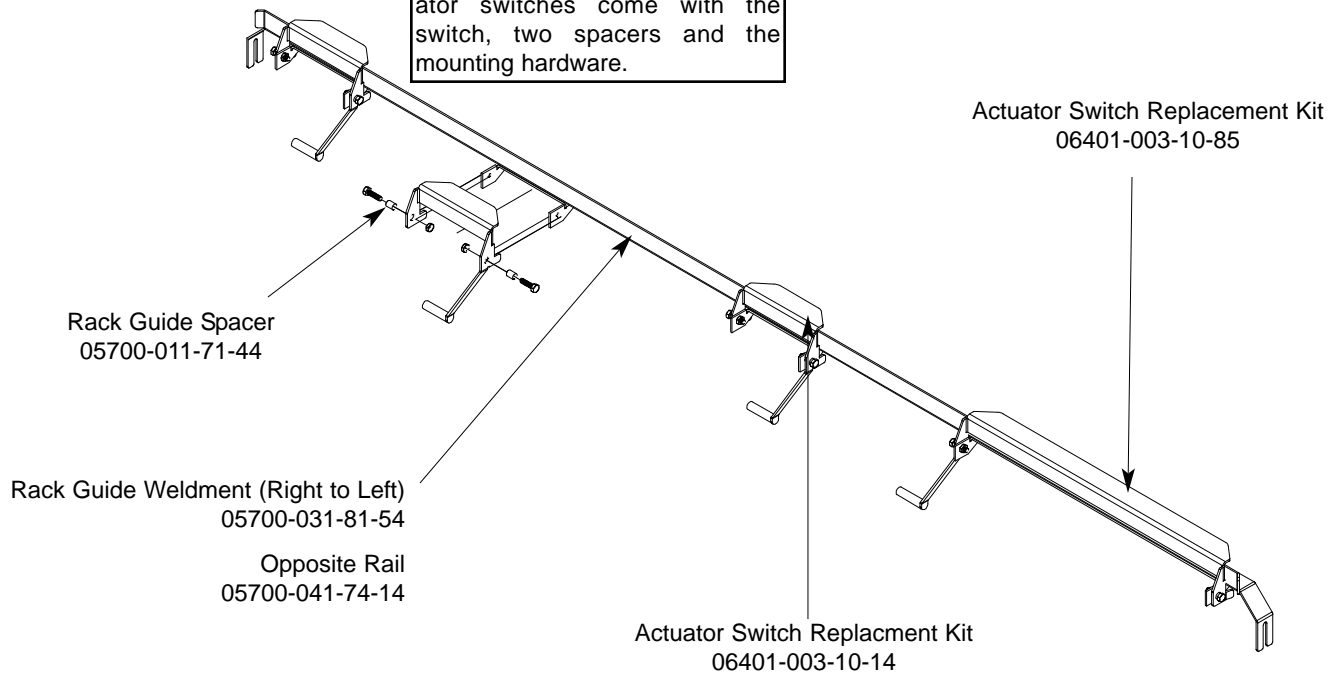

SECTION 5: PARTS SECTION
MISCELLANEOUS PARTS AND WELDMENTS

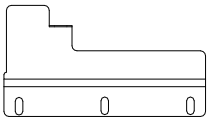

Plate, Left Water Directional
05700-021-79-27

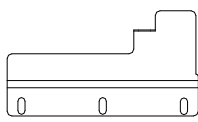

Plate, Right Water Directional
05700-021-79-23

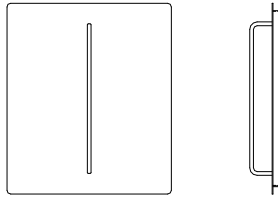

Run Off Sheet Weldment
05700-021-71-39

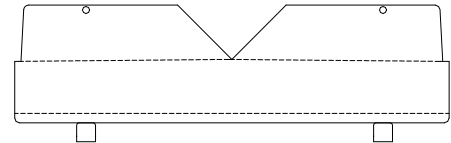

Splash Shield Weldment
05700-031-85-16

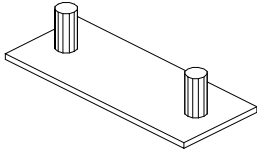

Hole Direction Plate Replacement Kit
06401-003-10-00

Replacement Kit Note:
The kit for the hole direction plate comes with the plate, a new gasket and the mounting hardware.

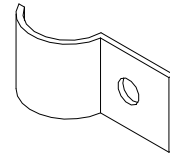

Pipe Clamp
05700-000-35-05

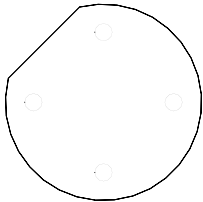

Rinse Drain Plate Replacement Kit
(TG Models Only)
06401-003-10-07

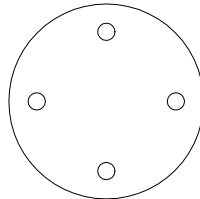

Rinse Drain Plug Replacement Kit
06401-003-10-06

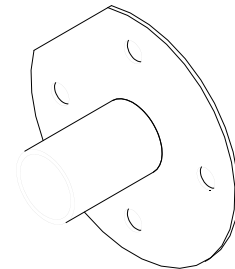

Rinse Drain Weldment Replacement Kit
06401-003-10-05

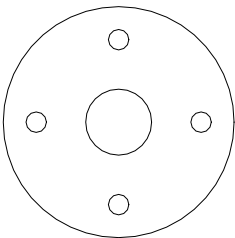

Rinse Drain Plate Gasket
05330-011-72-27

Replacement Kits Notes:
The kits for the drain weldments and drain plugs come with the weldments/parts, a new gasket and the mounting hardware.

Shoulder Bolt Wingnut Weldment
05700-002-46-02

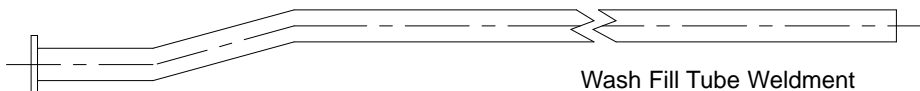
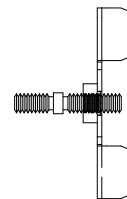

Wash Fill Tube Weldment
05700-021-71-21

Vellumoid Gasket
05330-111-42-81

Prewash Fill Tube Weldment
(AJ-66 & AJ-80 Models Only)
05700-021-74-76

SECTION 5: PARTS SECTION
STRAINERS

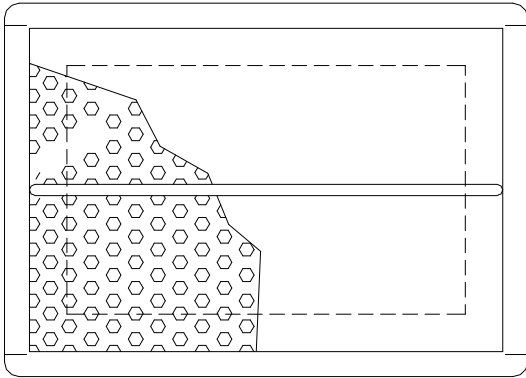

Front Strainer Weldment
05700-021-85-10

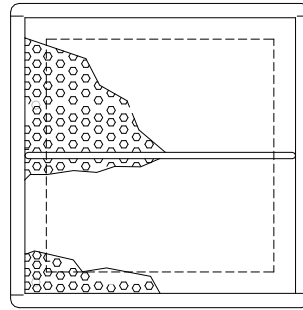

Back Strainer Weldment
05700-021-85-11

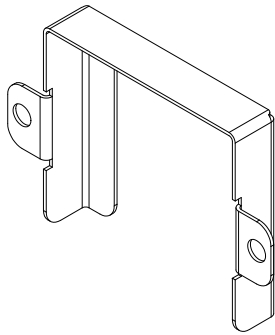

Overflow Strainer Support
05700-001-96-48

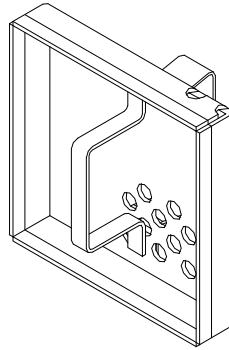

**Drain Guard
Strainer Weldment**
05700-002-09-15

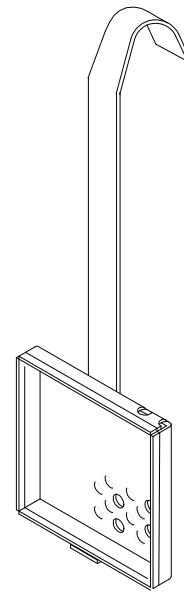

Wash Intake Strainer Weldment (TG Models)
05700-002-51-52

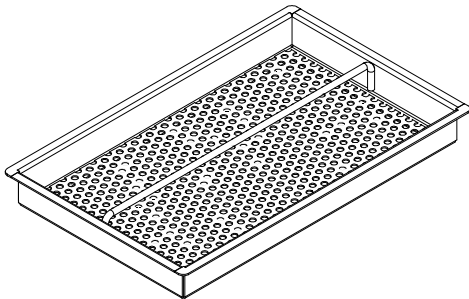

Tub Strainer Weldment (TG Models)
05700-002-03-21

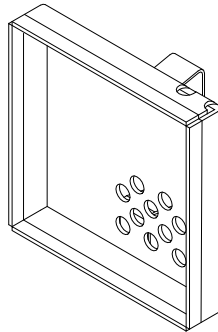

**Screen Strainer
with Handle Weldment**
05700-002-09-04

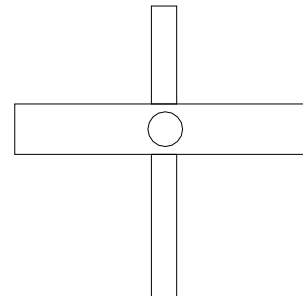

Wash Strainer Separator Weldment
05700-031-84-38

SECTION 5: PARTS SECTION
FLOAT SWITCH COMPONENTS/SCRAP BASKETS

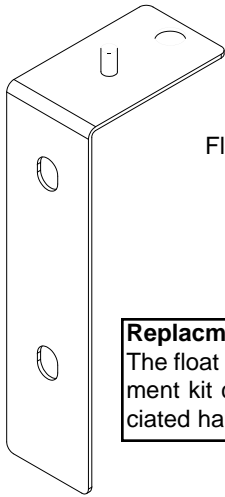

Float Switch Support Bracket
 Replacement Kit
 06401-003-11-77

Replacement Kit Note:
 The float switch support bracket replacement kit contains the bracket and associated hardware for mounting.

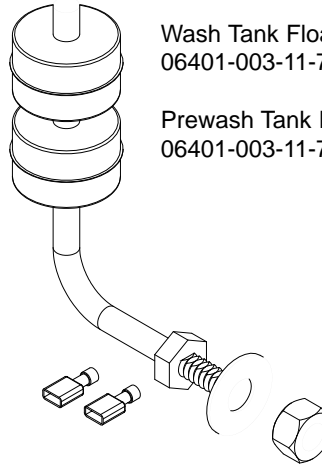

Wash Tank Float Switch Replacement Kit
 06401-003-11-75

Prewash Tank Float Switch Replacement Kit
 06401-003-11-76

Replacement Kit Note:
 The float switch replacement kits contain the float switch with associated terminals, the flat washer and the nut.

Service Agent Note:
 Remember than when reinstalling the float switch that the flat washer goes inside against the tub wall while the nut is on the outside of the tub.

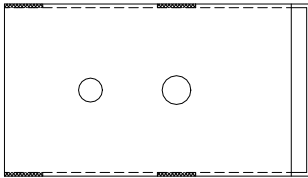

Float Switch Cover
 05700-021-75-71

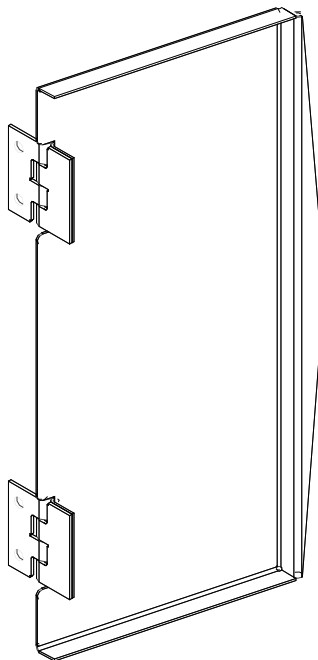

Scrap Basket Lid
 Weldment
 05700-002-56-55

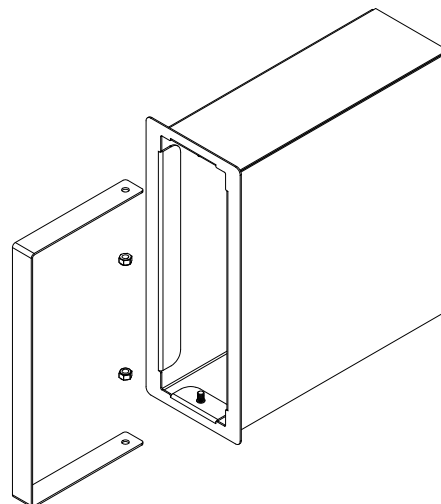

Scrap Basket Assembly
 06401-002-11-21

SECTION 5: PARTS SECTION
CURTAINS/TUB MAGNETS

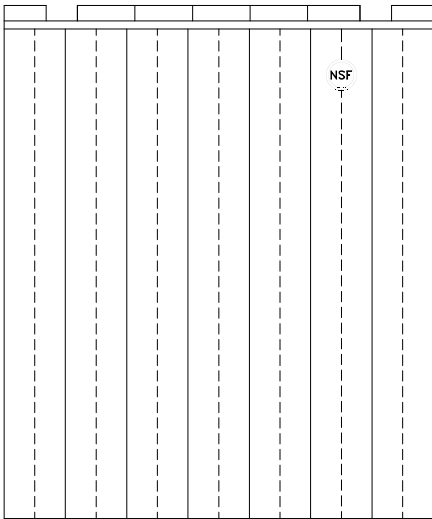

Curtain, 24 1/2" Long x 20-1/2" Wide
TG MODELS ONLY
08415-002-47-37

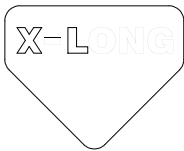

Extra Long Curtain Decal
TG MODELS ONLY
09905-002-52-69

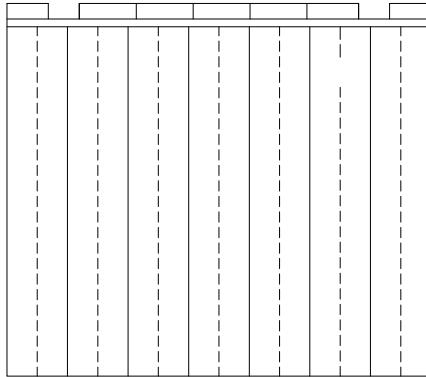

Curtain, 21" Long x 20-1/2" Wide
08415-131-73-45

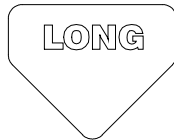

Long Curtain Decal
09905-011-73-84

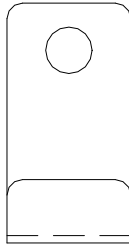

Curtain Hook
05700-011-83-54

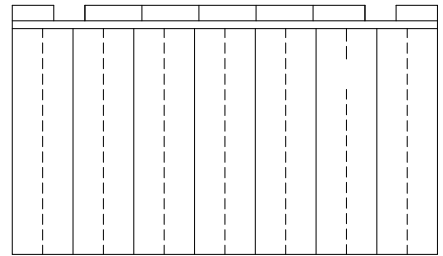

Curtain, 12" Long x 20-1/2" Wide
08415-131-73-44



Short Curtain Decal
09905-011-73-82

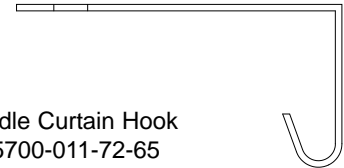

Middle Curtain Hook
05700-011-72-65

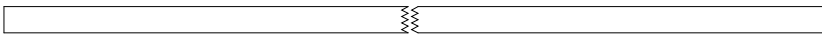

Curtain Rod
05700-021-73-43

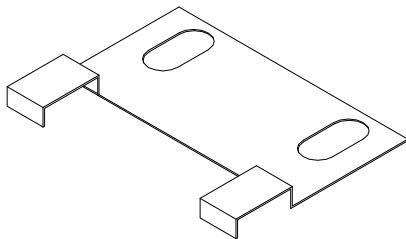

Limit Switch Bracket
05700-021-71-18

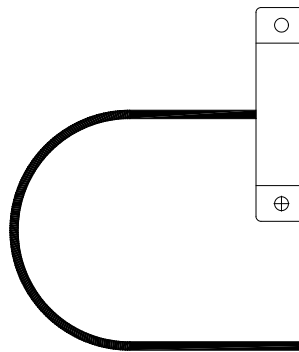

Conveyor Switch Replacement Kit
06401-003-11-79

Replacement Kit Note:
The conveyor switch replacement kit comes with the switch, a terminal and a wire nut.

Service Note:
The cord for the conveyor switch needs to be cut to length in the field and have the pink terminal applied there.

SECTION 5: PARTS SECTION
VENT COWL ASSEMBLY/VENT SCOOP OPTION

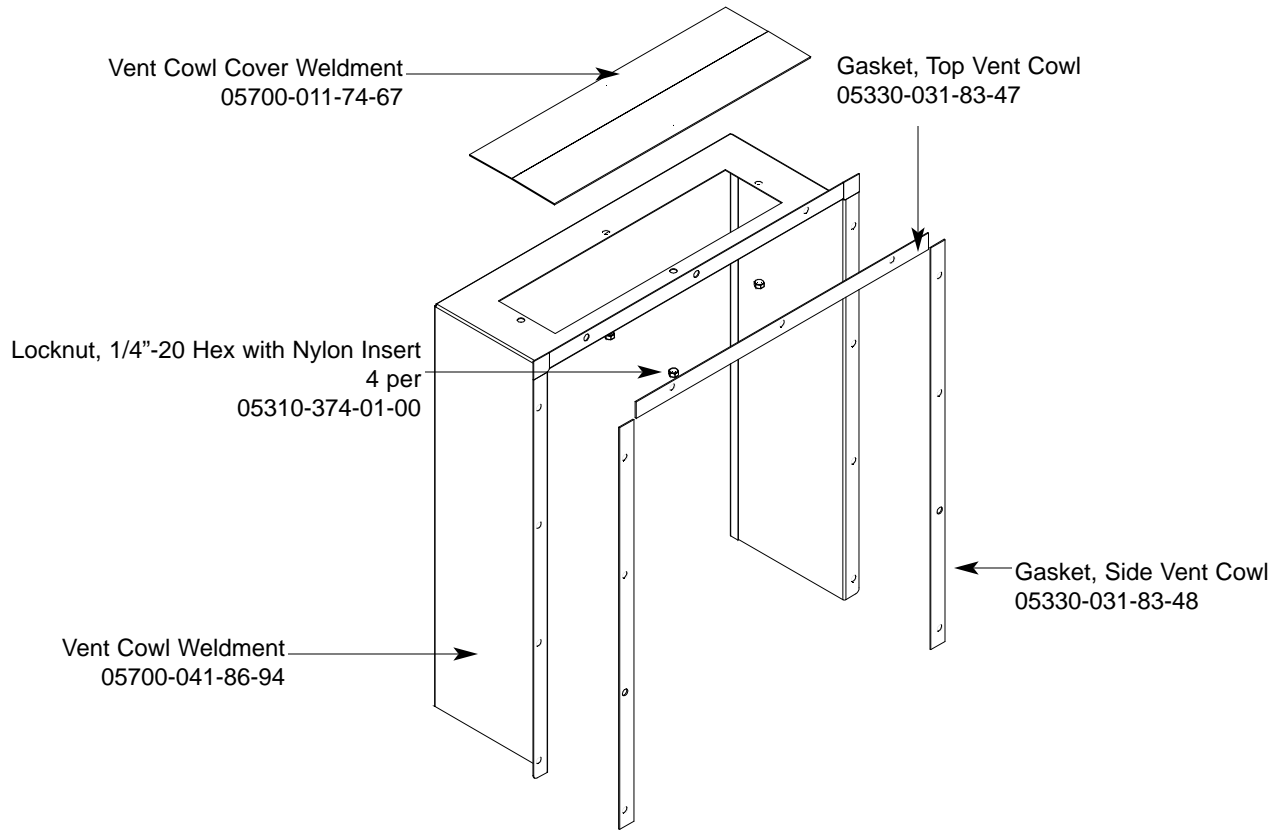

VENT SCOOP OPTION

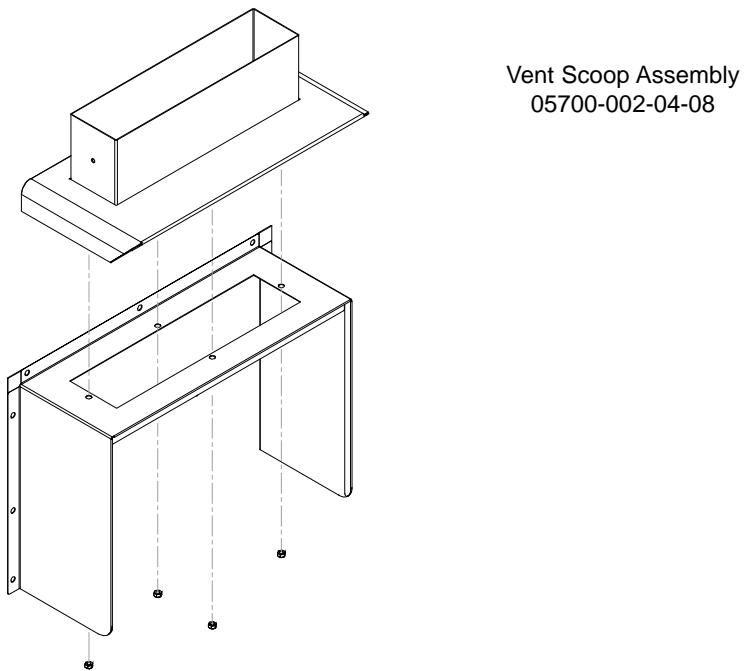

SECTION 5: PARTS SECTION
EXHAUST FAN CONTROL/TABLE LIMIT SWITCH OPTIONS

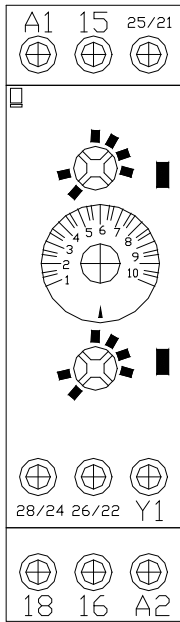

Delay Timer
 05945-011-65-44

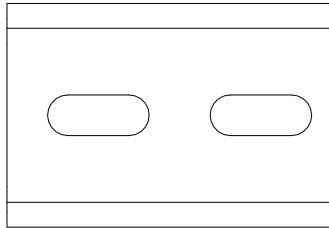

2" Din Rail
 05700-002-36-09

**FAN LOAD ON TIMER OUTPUT
 5A, 1/4HP, 240 V AC MAX**

Decal, Fan Load
 09905-003-32-20

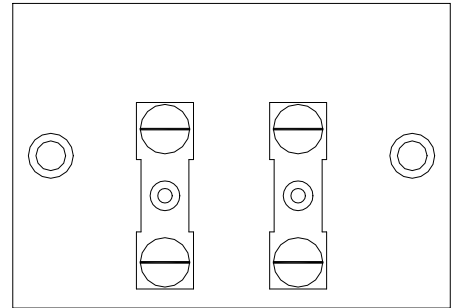

Terminal Board
 05940-011-84-41

Kit, Exhaust Fan - Electric & Steam Models
 05700-031-90-53

Kit, Exhaust Fan - Gas Models
 05700-003-14-59

Limit Switch
 05930-002-62-81

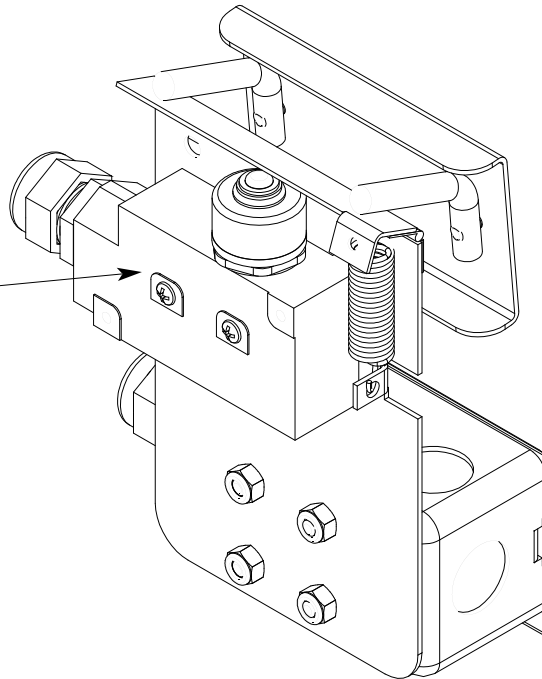

Striker Plate Limit Switch
 Assembly
 05700-002-62-94

SECTION 5: PARTS SECTION
SIDE LOADER TRACK ASSEMBLY/LEG REPLACEMENTS

**Side loader track assembly
(left to right model shown).**

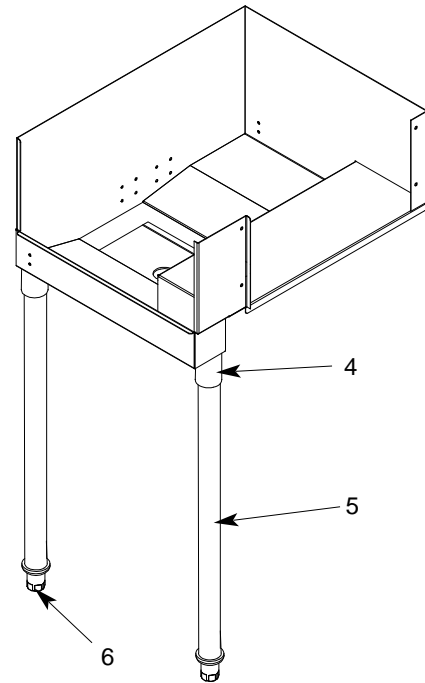
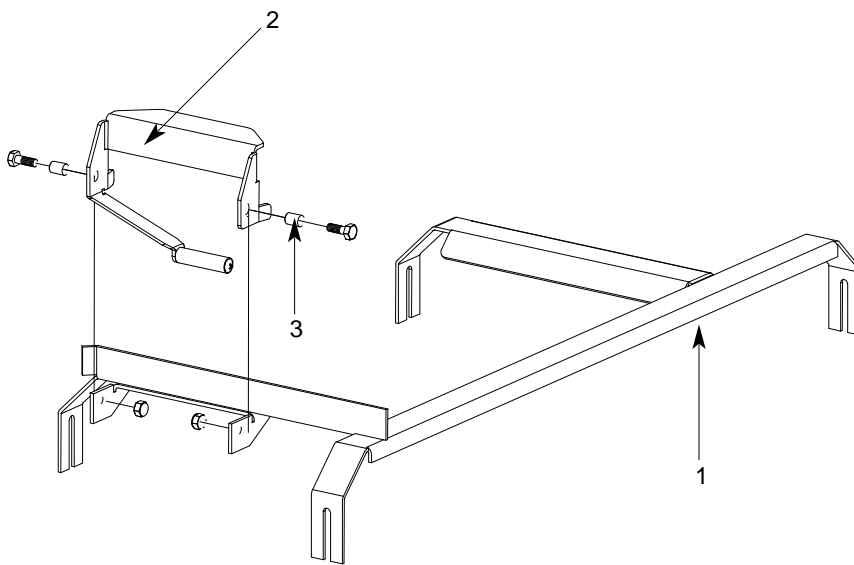

ITEM	QTY	DESCRIPTION
1	1	Track Weldment (Left to Right) 24"
	1	Track Weldment (Right to Left) 24"
	1	Track Weldment (Left to Right) 30"
	1	Track Weldment (Right to Left) 30"
2	1	Actuator Switch Replacement Kit
3	2	Spacer
4	1	Leg Socket Replacement Kit
5	1	Leg Support Replacement Kit
6	1	Bullet Foot

Mfg. No.
05700-031-78-98
05700-031-95-20
05700-003-04-57
05700-003-04-58
06401-003-10-64
05700-011-71-44
06401-003-09-79
06401-003-09-80
05340-108-01-03

Replacement Kits Notes:

The actuator switch replacement kit comes with the actuator weldment, mounting hardware and (2) spacers.

The leg socket replacement kit has the leg socket, mounting hardware and set screw.

The leg support replacement kit has the leg and the bullet foot included.

SECTION 5: PARTS SECTION

SIDE LOADER PAWL BAR ASSEMBLIES/STRAINER/MAGNET

Replacement Kit Note:
The kits for the pawl bars come with the bar weldment, (3) dogs and the hardware.

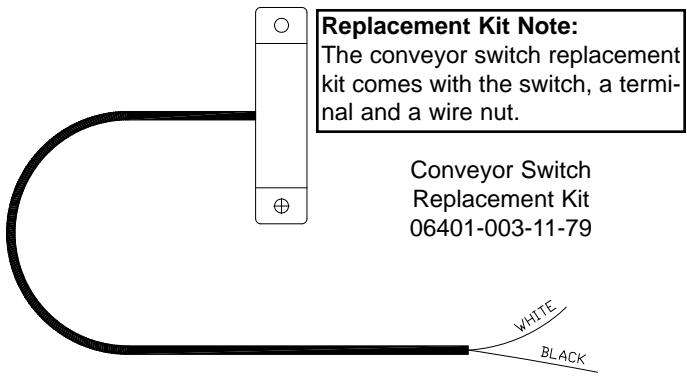
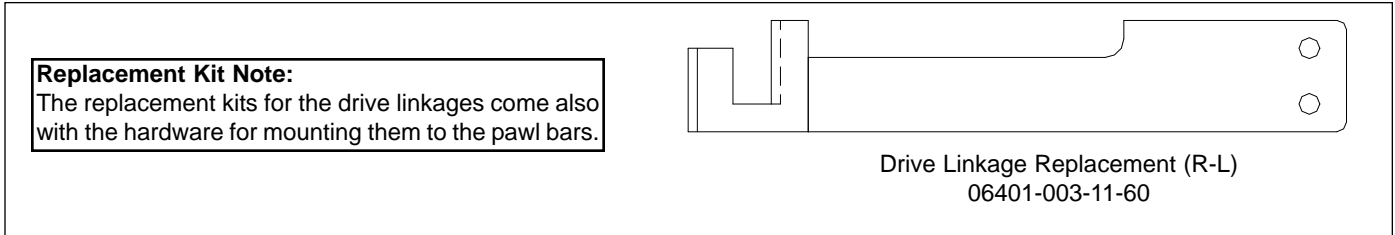
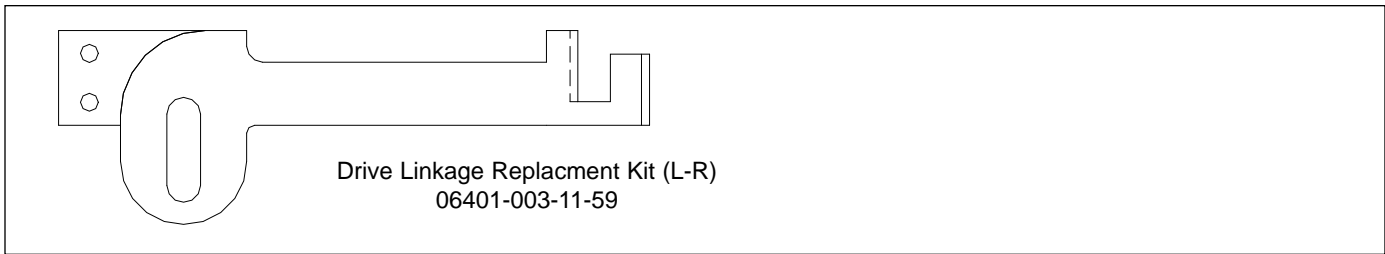
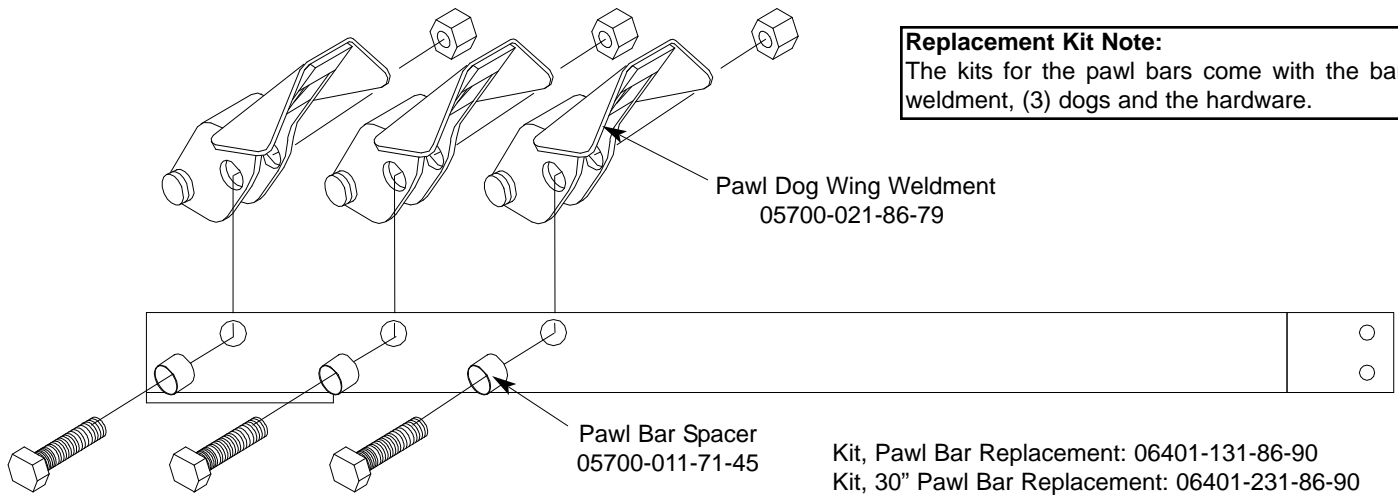

Service Note:
The cord for the conveyor switch needs to be cut to length in the field and have the pink terminal applied there.

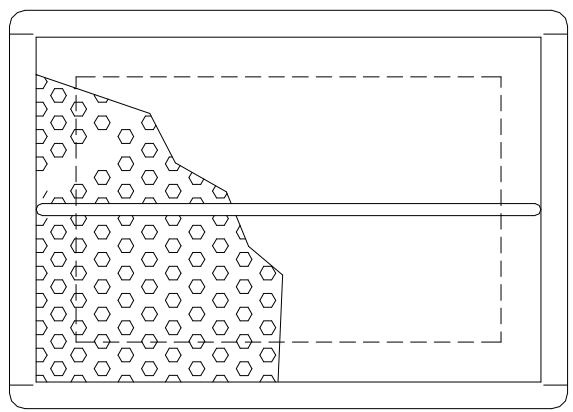

Front Strainer Weldment
05700-021-85-10

SECTION 5: PARTS SECTION
SIDE LOADER PAWL BAR ASSOCIATED PARTS

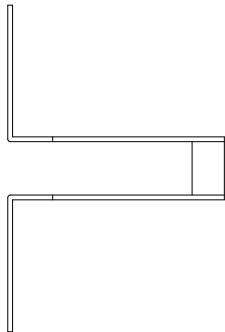

Pawl Bar Roller Bracket
05700-031-77-94

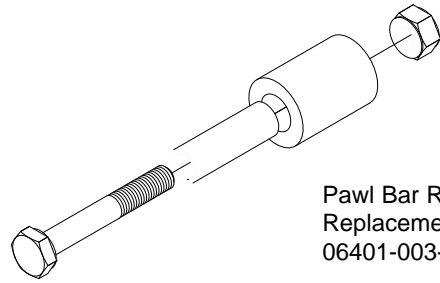

Pawl Bar Roller Replacement Kit
06401-003-11-80

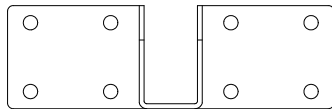

Replacement Kit Notes:

The replacement kit for the pawl bar roller comes with the roller, roller shaft, hardware and locknut as shown.

Associated Hardware:

Washer, 1/4"-20 I.D.

05311-174-01-00

Locknut, 1/4"-20 S.S. Hex w/Nylon Insert

05310-374-01-00

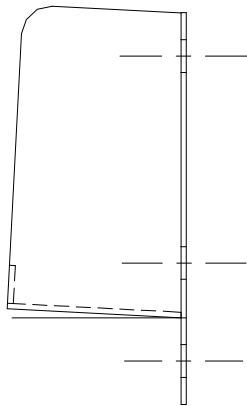

Pawl Bar Gutter Weldment Replacement Kit
06401-003-09-95

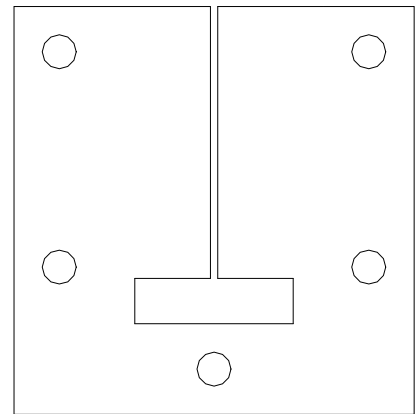
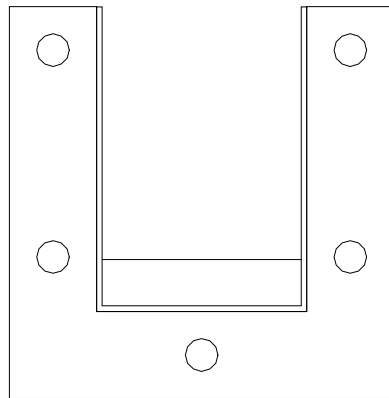

Drive Gutter Gasket
05330-011-68-55

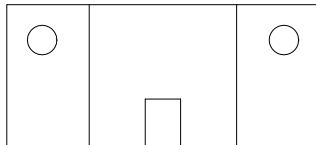

Top Guide Block

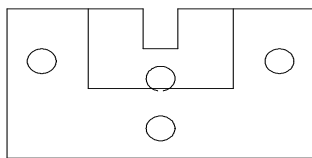

Bottom Guide Block

Guide Block Replacement Kit

06401-003-10-15

Replacement Kit Notes:

The pawl bar gutter kit includes the weldment, locknuts and the gasket. The guide block kits includes the blocks and the gasket.

Service Note:

Because of wear patterns that develop over time, it is highly recommended that when replacing either of the guide blocks, that the other be replaced as well from the kit.

SECTION 5: PARTS SECTION
SIDE LOADER VENT COWL OPTION

Vent Cowl Replacement Kit (Left to Right)
 06401-003-11-81

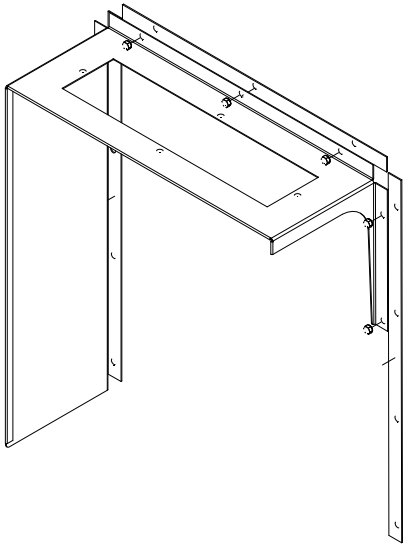

Vent Cowl Replacement Kit (Right to Left)
 06401-003-11-83

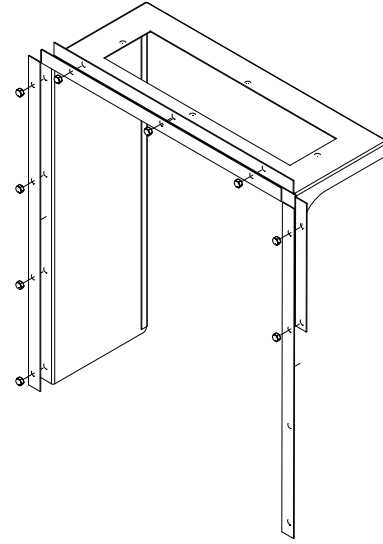

Service Note:
 One of the side gaskets that come in the kit will need to be cut to length in order to fit properly on the unit when replaced.

Replacement Kit Note:
 The replacement kit(s) for the vent cowls come with the cowls, the gaskets and mounting hardware.

Vent Cowl Gasket, Top: 05330-031-83-47
 Vent Cowl Gasket, Side: 05330-031-83-48

VENT SCOOP OPTION

Vent Scoop Assembly
 05700-002-04-08

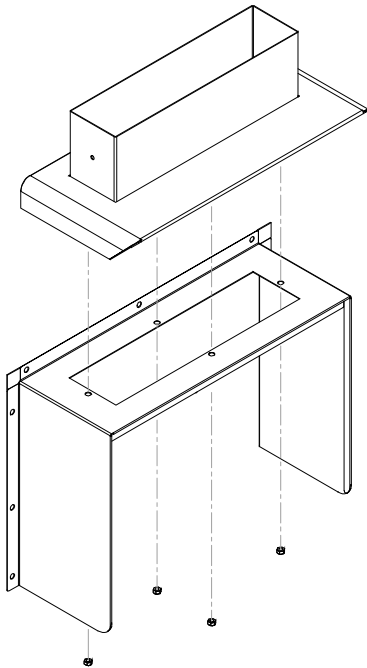

STANDARD ASSEMBLY

Vent Cowl Cover Replacement Kit
 06401-003-10-16

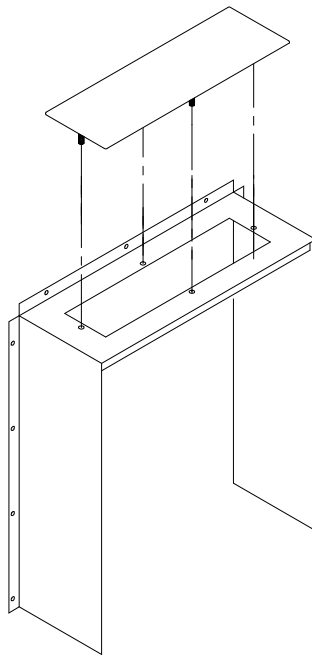

Replacement Kit Note:
 The cover kit contains the cover and the hardware for mounting it.

VENT COWL ASSEMBLY FOR HOODED SIDE LOADER OPTION
 05700-003-05-66

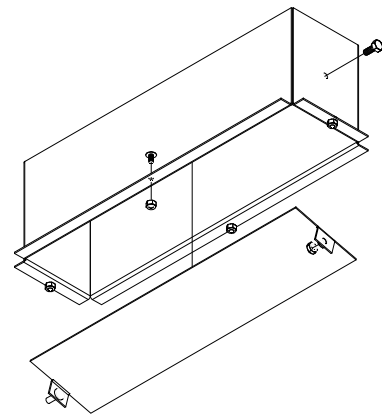

SECTION 5: PARTS SECTION

RINSE FILL OPTION

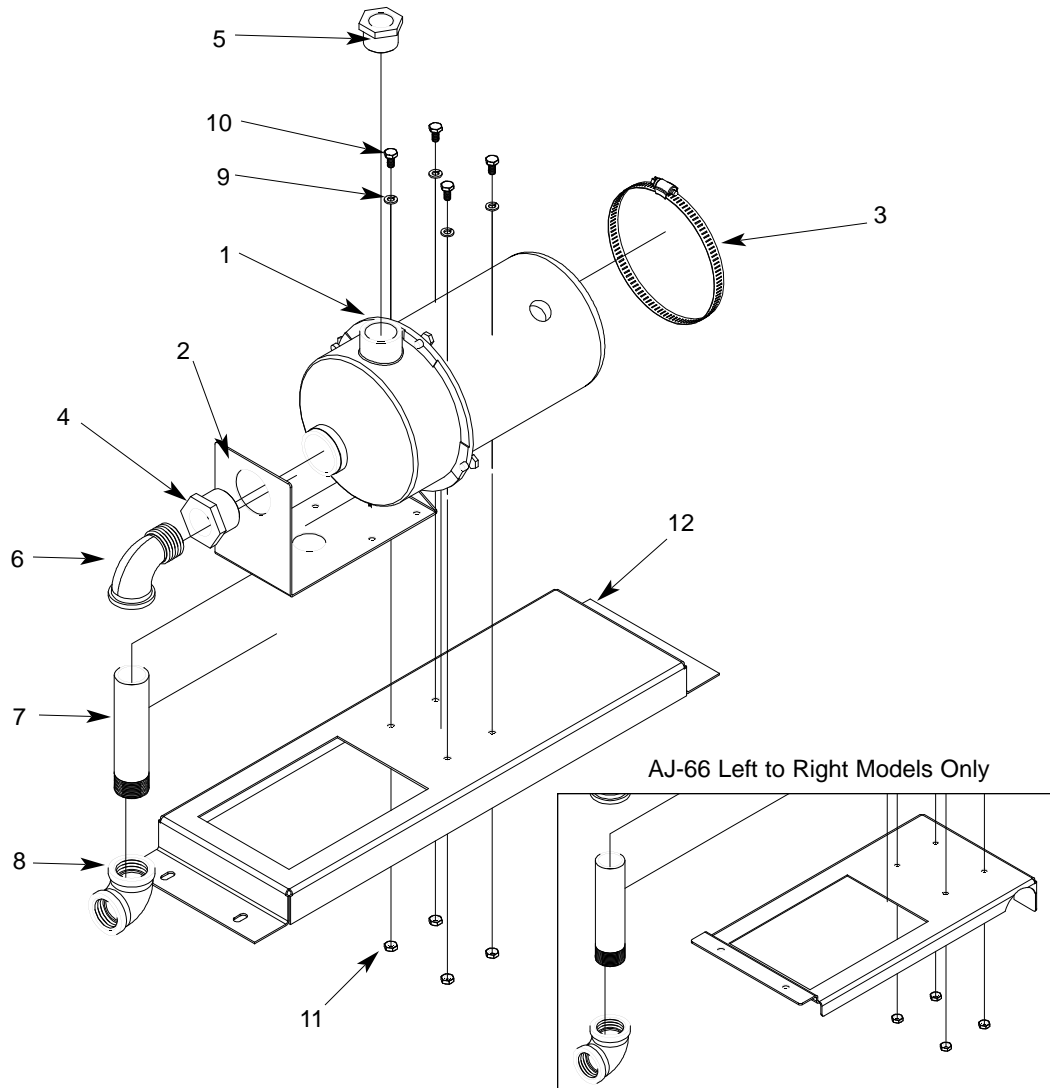

ITEM	QTY	DESCRIPTION	Mfg. No.
	1	Rinse Fill Motor Assembly	05700-002-40-25
	1	Rinse Fill Motor Assembly (AJ-66 Left to Right Models Only)	05700-002-48-22
1	1	Motor	06105-002-72-71
2	1	Bracket, Pump Mounting	05700-002-63-59
3	1	Clamp, Hose 5 5/8" to 6"	04730-011-34-90
4	1	Reducer Bushing, 1 1/4" to 1"	04730-002-73-62
5	1	Reducer Bushing 1" to 3/4"	04730-011-65-14
6	1	Elbow, 90 Deg., 1" Street	04730-002-11-99
7	1	Nipple, 1" NPT x 6" Long Brass	04730-002-12-00
8	1	Elbow, 90 Deg. Brass Female	04730-002-12-55
9	4	Lockwasher, 1/4"	05311-274-01-00
10	4	Bolt, 1/4"-20 x 1/2" Long	05305-274-02-00
11	4	Nut, Hex S/S 1/4"-20	05310-274-01-00
12	1	Rinse Motor Mounting Bracket	05700-002-38-90
12	1	Rinse Motor Mounting Bracket (AJ-66 Left to Right Models Only)	05700-002-39-33

SECTION 6: ELECTRICAL SCHEMATICS

SECTION 6: ELECTRICAL SCHEMATICS

AJ-44TE (208-230 VOLT/60 HZ/1 PHASE)

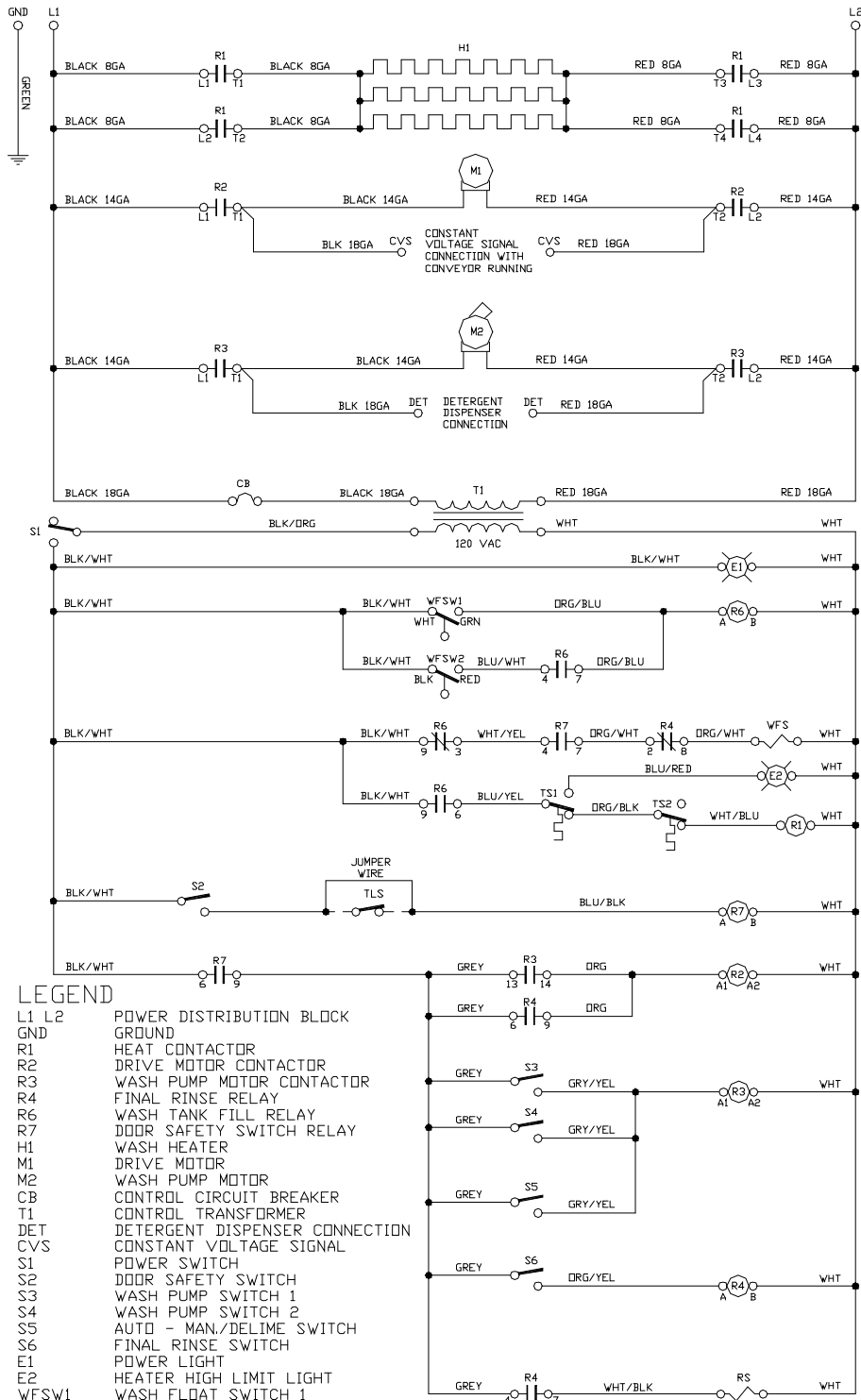

LEGEND

- L1 L2 POWER DISTRIBUTION BLOCK
- GND GROUND
- R1 HEAT CONTACTOR
- R2 DRIVE MOTOR CONTACTOR
- R3 WASH PUMP MOTOR CONTACTOR
- R4 FINAL RINSE RELAY
- R6 WASH TANK FILL RELAY
- R7 DOOR SAFETY SWITCH RELAY
- H1 WASH HEATER
- M1 DRIVE MOTOR
- M2 WASH PUMP MOTOR
- CB CONTROL CIRCUIT BREAKER
- T1 CONTROL TRANSFORMER
- DET DETERGENT DISPENSER CONNECTION
- CVS CONSTANT VOLTAGE SIGNAL
- S1 POWER SWITCH
- S2 DOOR SAFETY SWITCH
- S3 WASH PUMP SWITCH 1
- S4 WASH PUMP SWITCH 2
- S5 AUTO - MAN/DELIME SWITCH
- S6 FINAL RINSE SWITCH
- E1 POWER LIGHT
- E2 HEATER HIGH LIMIT LIGHT
- WFSW1 WASH FLDAT SWITCH 1
- WFSW2 WASH FLDAT SWITCH 2
- TS1 HEATER HIGH LIMIT THERMOSTAT
- TS2 WASH REGULATING THERMOSTAT
- TLS TABLE LIMIT SWITCH (OPTIONAL)
- WFS WASH FILL SOLENOID
- RS FINAL RINSE SOLENOID

9905-031-72-94c

SECTION 6: ELECTRICAL SCHEMATICS

AJ-44TE (208-230 VOLT/60 HZ/3 PHASE)

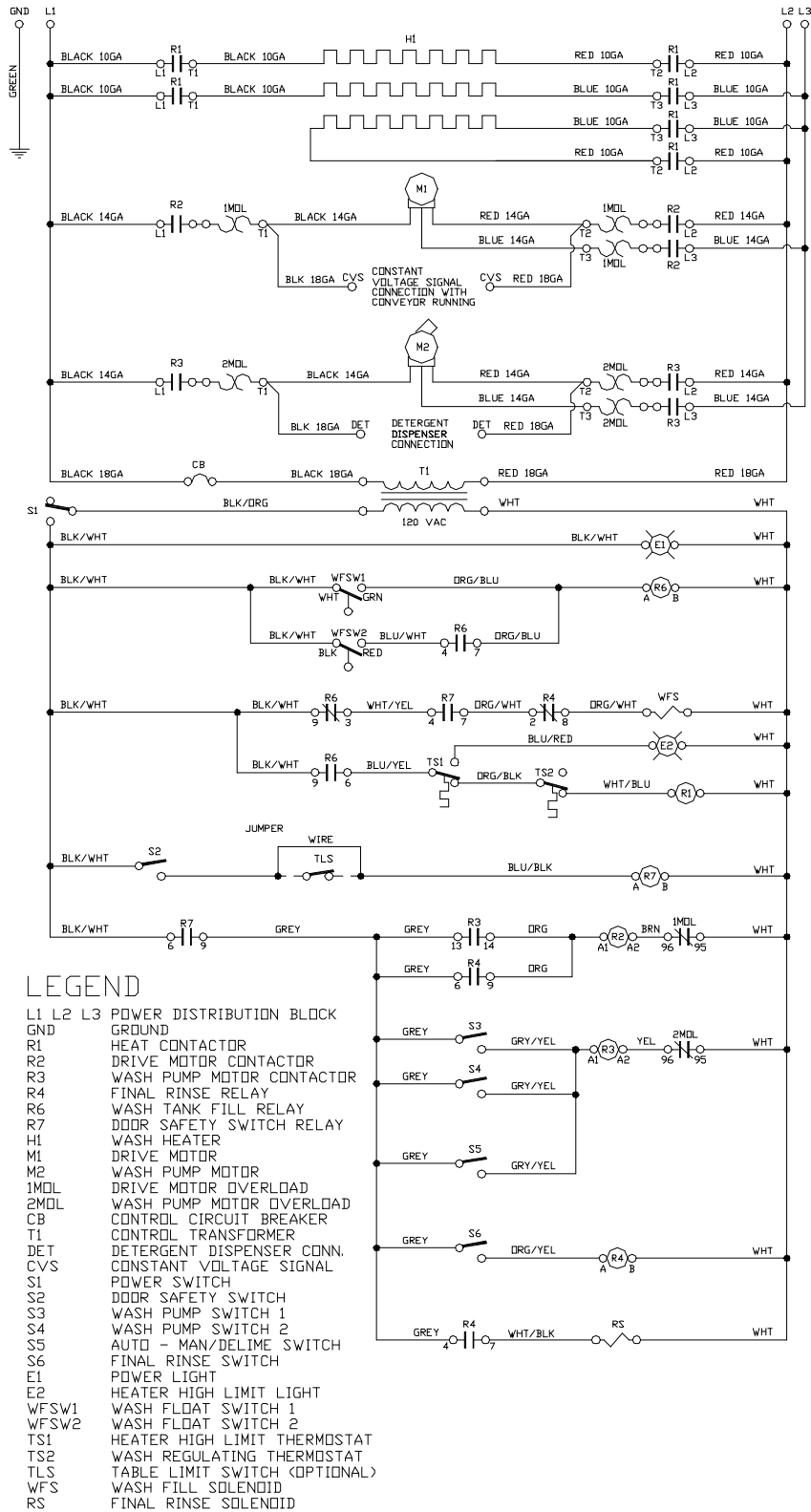

9905-031-70-79

SECTION 6: ELECTRICAL SCHEMATICS

AJ-44TE (460 VOLT/60 HZ/3 PHASE)

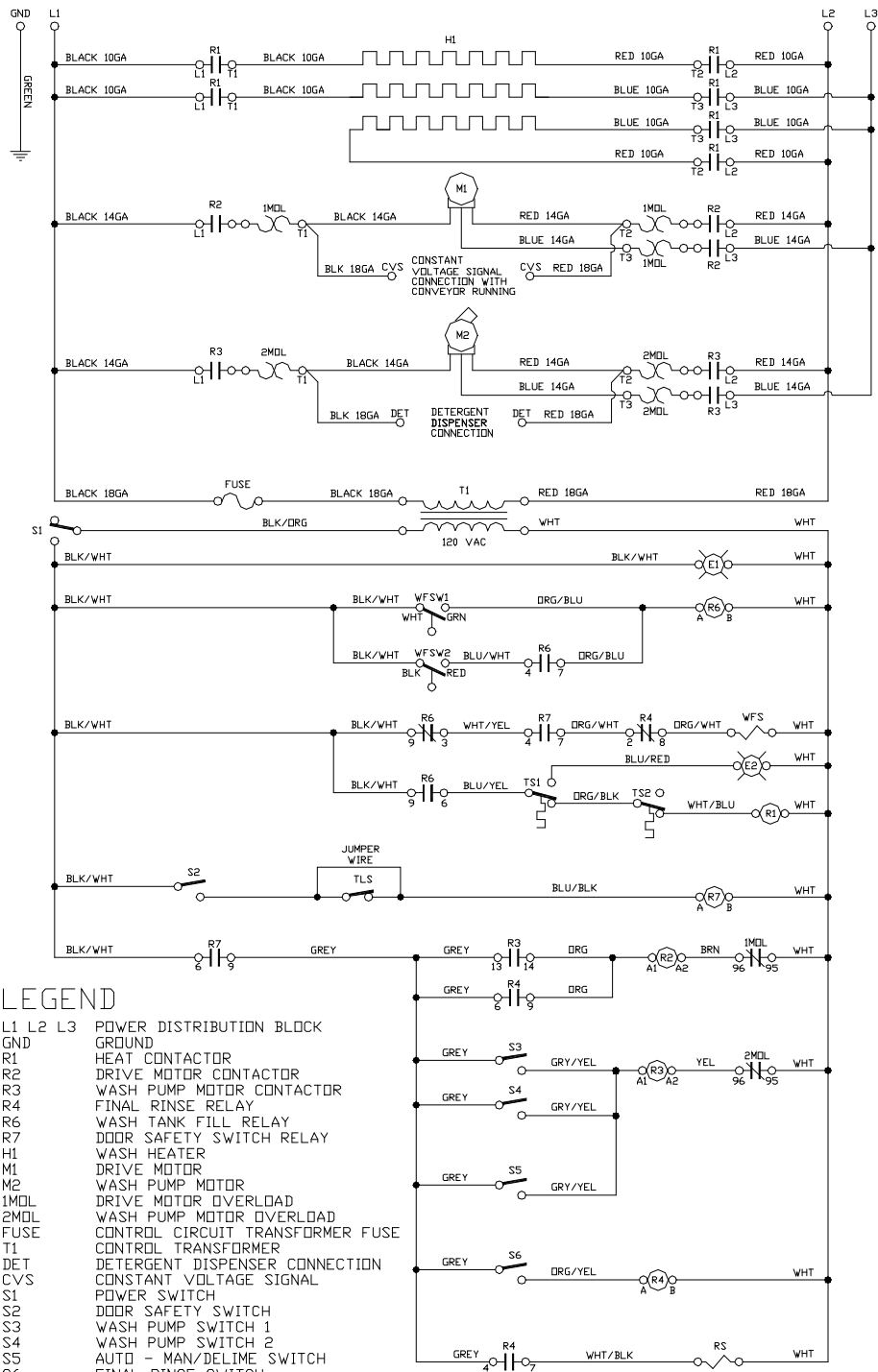

9905-031-72-90

SECTION 6: ELECTRICAL SCHEMATICS

AJ-44TG (208-230 VOLT/60 HZ/1 PHASE)

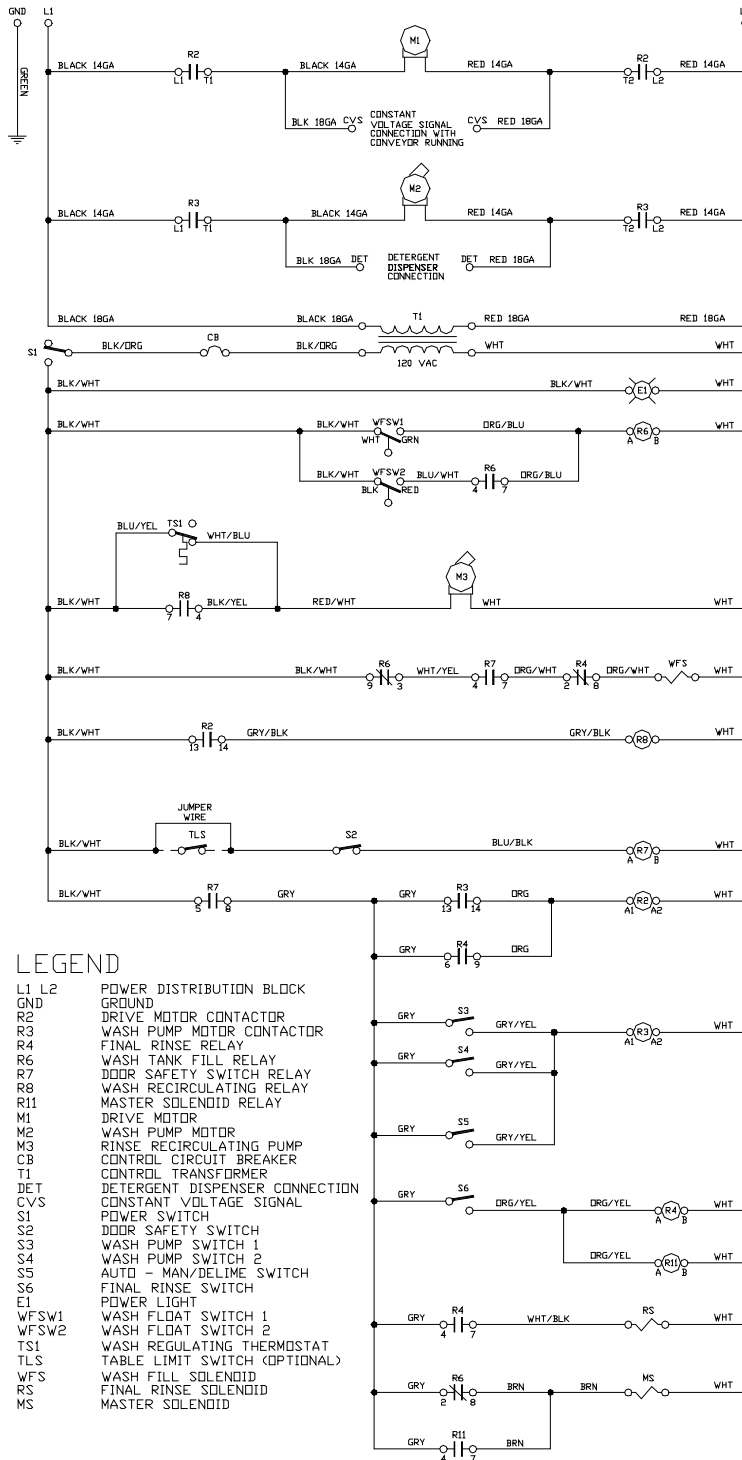

9905-002-52-42

SECTION 6: ELECTRICAL SCHEMATICS

AJ-44TG (208-230 VOLT/60 HZ/3 PHASE)

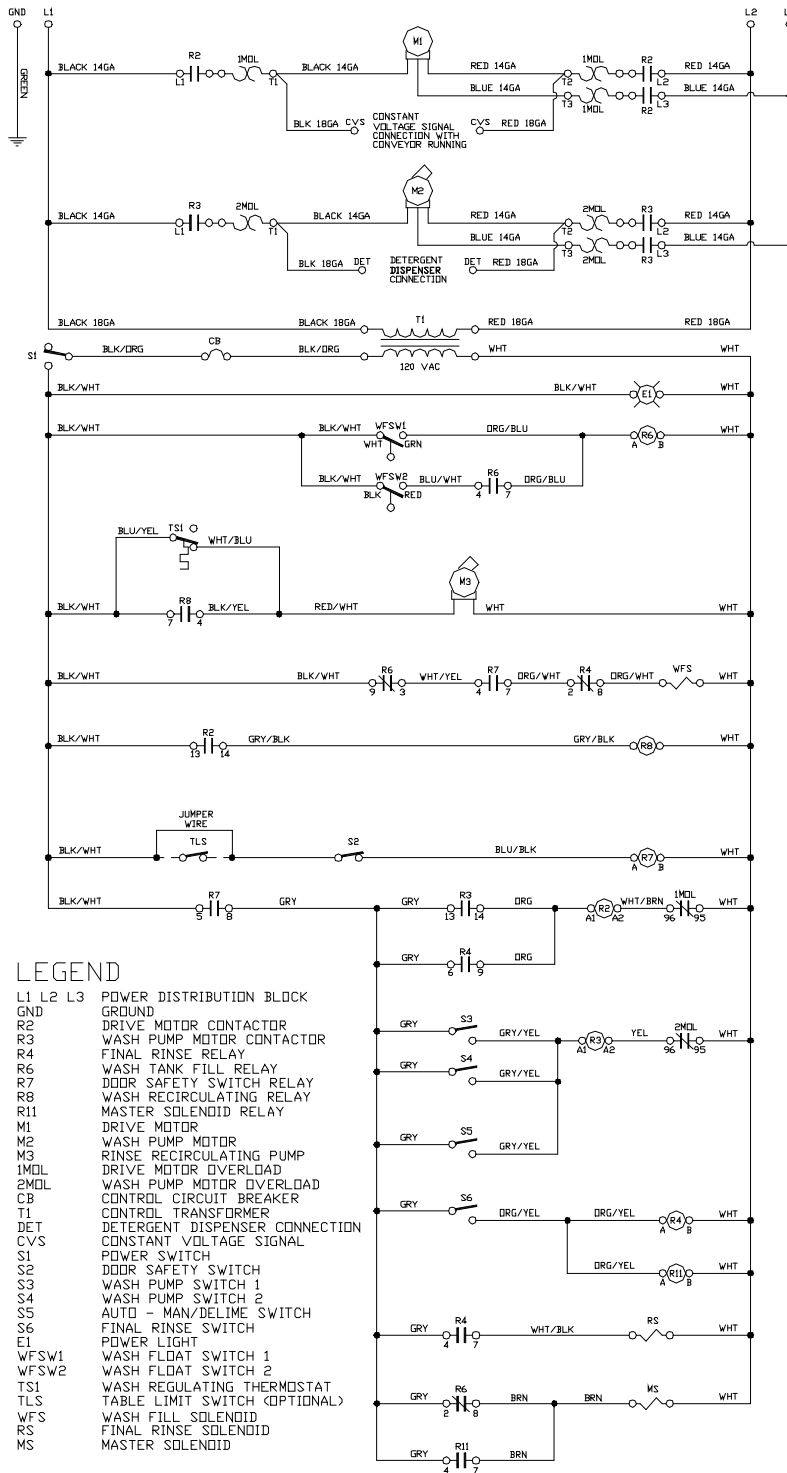

LEGEND

- L1 L2 L3 POWER DISTRIBUTION BLOCK
- GND GROUND
- R2 DRIVE MOTOR CONTACTOR
- R3 WASH PUMP MOTOR CONTACTOR
- R4 FINAL RINSE RELAY
- R6 WASH TANK FILL RELAY
- R7 DOOR SAFETY SWITCH RELAY
- R8 WASH RECIRCULATING RELAY
- R11 MASTER SOLENOID RELAY
- M1 DRIVE MOTOR
- M2 WASH PUMP MOTOR
- M3 RINSE RECIRCULATING PUMP
- 1MOL DRIVE MOTOR OVERLOAD
- 2MOL WASH PUMP MOTOR OVERLOAD
- CB CONTROL CIRCUIT BREAKER
- T1 CONTROL TRANSFORMER
- DET DETERGENT DISPENSER CONNECTION
- CVS CONSTANT VOLTAGE SIGNAL
- S1 POWER SWITCH
- S2 DOOR SAFETY SWITCH
- S3 WASH PUMP SWITCH 1
- S4 WASH PUMP SWITCH 2
- S5 AUTO - MAN/DELIME SWITCH
- S6 FINAL RINSE SWITCH
- E1 POWER LIGHT
- WFSW1 WASH FLDAT SWITCH 1
- WFSW2 WASH FLDAT SWITCH 2
- TS1 WASH REGULATING THERMOSTAT
- TLS TABLE LIMIT SWITCH (OPTIONAL)
- WFS WASH FILL SOLENOID
- RS FINAL RINSE SOLENOID
- MS MASTER SOLENOID

9905-002-33-11a

SECTION 6: ELECTRICAL SCHEMATICS

AJ-44TG (460 VOLT/60 HZ/3 PHASE)

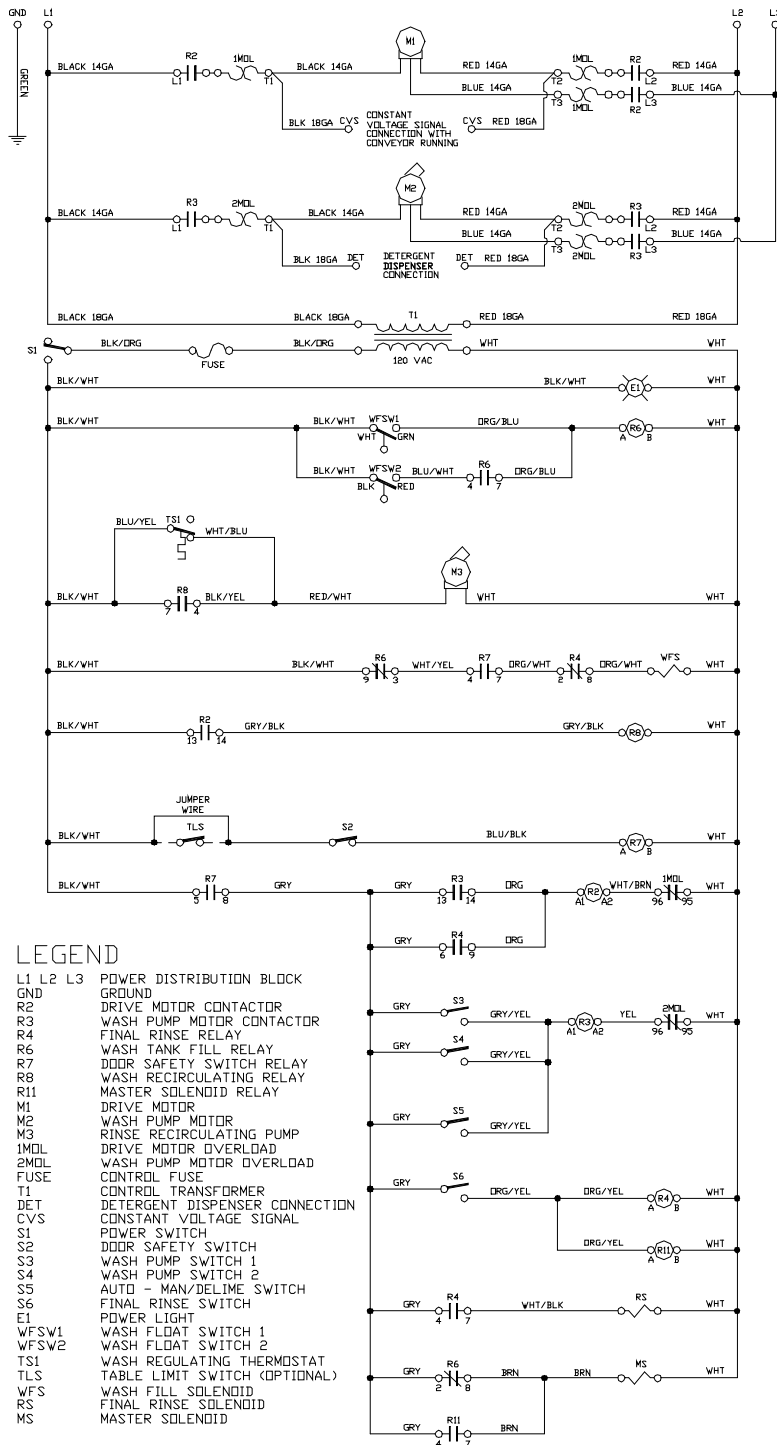

9905-002-53-24

SECTION 6: ELECTRICAL SCHEMATICS

AJ-44TS (208-230 VOLT/60 HZ/1 PHASE)

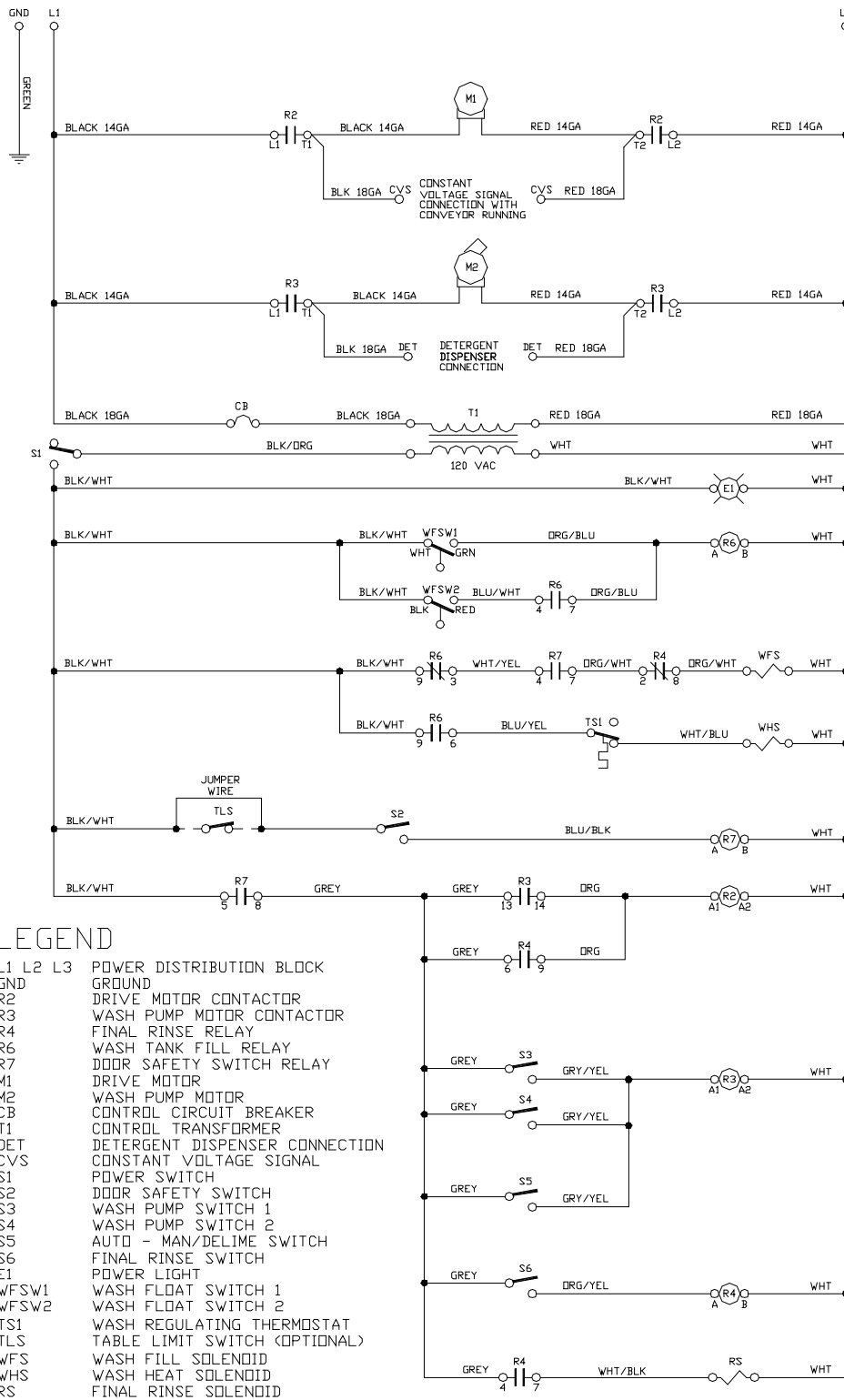

9905-031-80-23a

SECTION 6: ELECTRICAL SCHEMATICS

AJ-44TS (208-230 VOLT/60 HZ/3 PHASE)

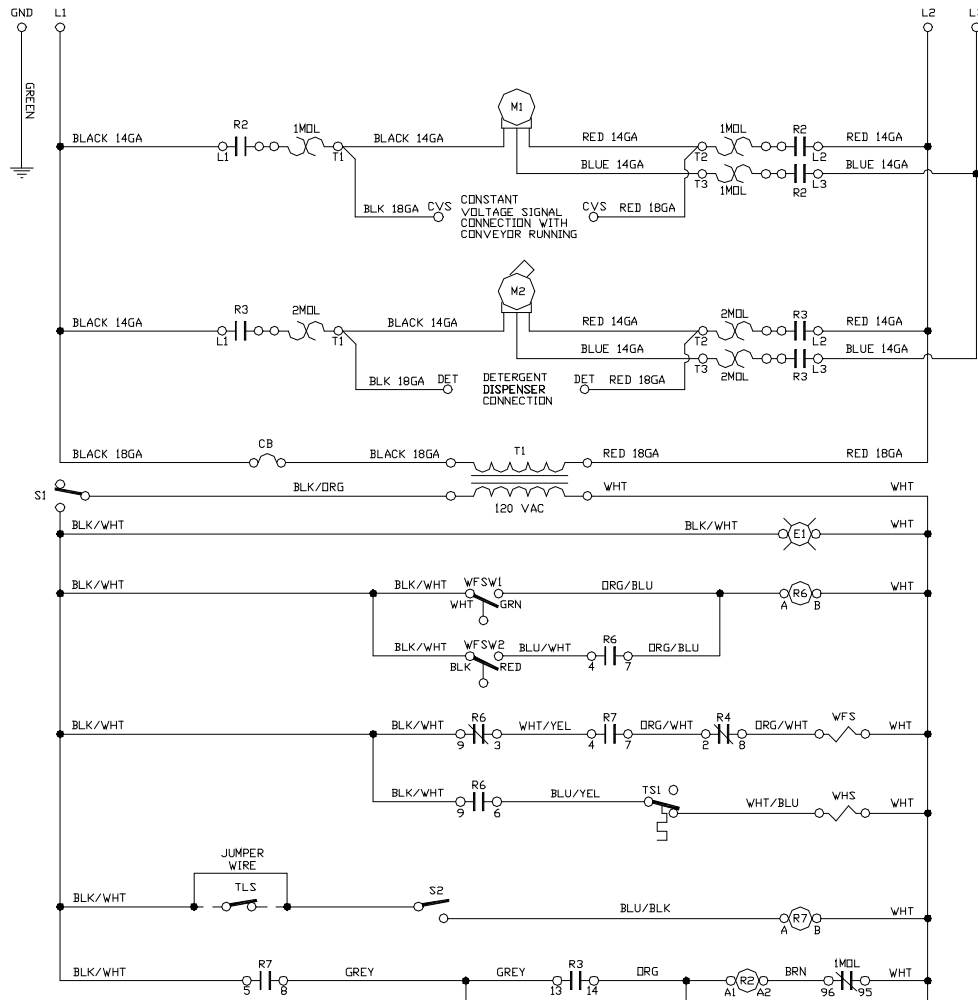

LEGEND

- L1 L2 L3 POWER DISTRIBUTION BLOCK
- GND GROUND
- R2 DRIVE MOTOR CONTACTOR
- R3 WASH PUMP MOTOR CONTACTOR
- R4 FINAL RINSE RELAY
- R6 WASH TANK FILL RELAY
- R7 DOOR SAFETY SWITCH RELAY
- M1 DRIVE MOTOR
- M2 WASH PUMP MOTOR
- 1MDL DRIVE MOTOR OVERLOAD
- 2MDL WASH PUMP MOTOR OVERLOAD
- CB CONTROL CIRCUIT BREAKER
- T1 CONTROL TRANSFORMER
- DET DETERGENT DISPENSER CONNECTION
- CVS CONSTANT VOLTAGE SIGNAL
- S1 POWER SWITCH
- S2 DOOR SAFETY SWITCH
- S3 WASH PUMP SWITCH 1
- S4 WASH PUMP SWITCH 2
- S5 AUTO - MAN/DELIME SWITCH
- S6 FINAL RINSE SWITCH
- E1 POWER LIGHT
- WFSW1 WASH FLOAT SWITCH 1
- WFSW2 WASH FLOAT SWITCH 2
- TS1 WASH REGULATING THERMOSTAT
- TLS TABLE LIMIT SWITCH (OPTIONAL)
- WFS WASH FILL SOLENOID
- WHS WASH HEAT SOLENOID
- RS FINAL RINSE SOLENOID

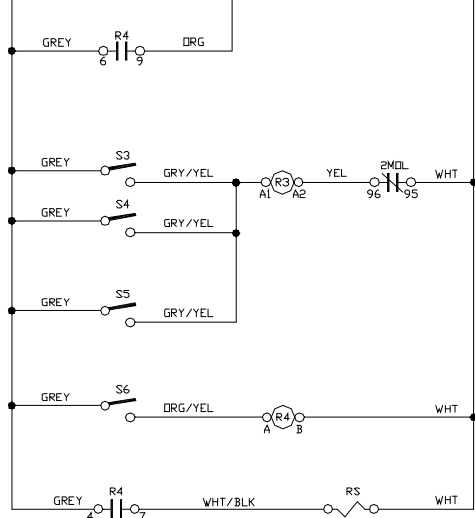

9905-031-80-24

SECTION 6: ELECTRICAL SCHEMATICS

AJ-44TS (460 VOLT/60 HZ/3 PHASE)

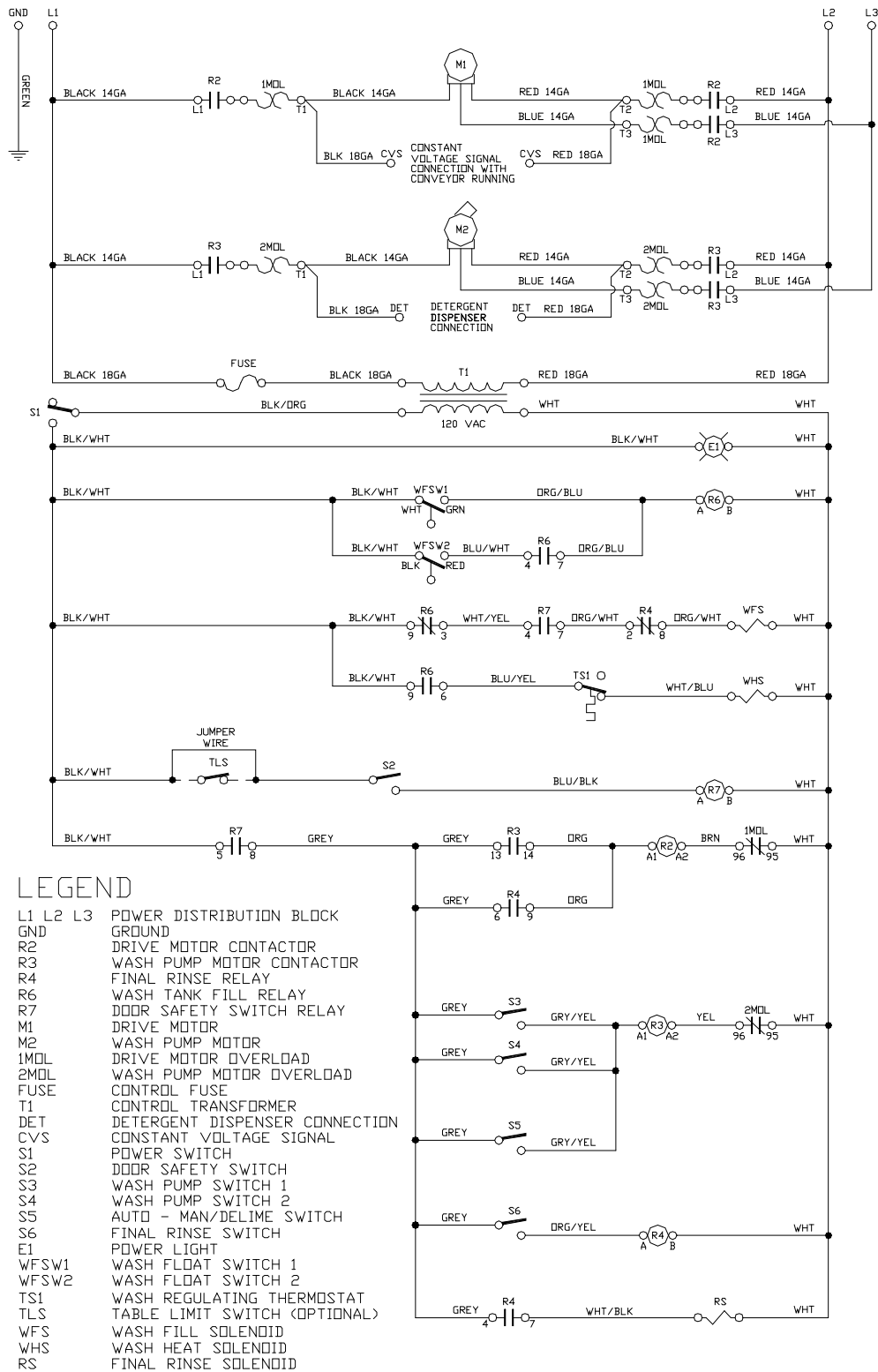

9905-031-80-26

SECTION 6: ELECTRICAL SCHEMATICS

AJ-66TE & AJ-80TE (208-230 VOLT/60 HZ/1 PHASE)

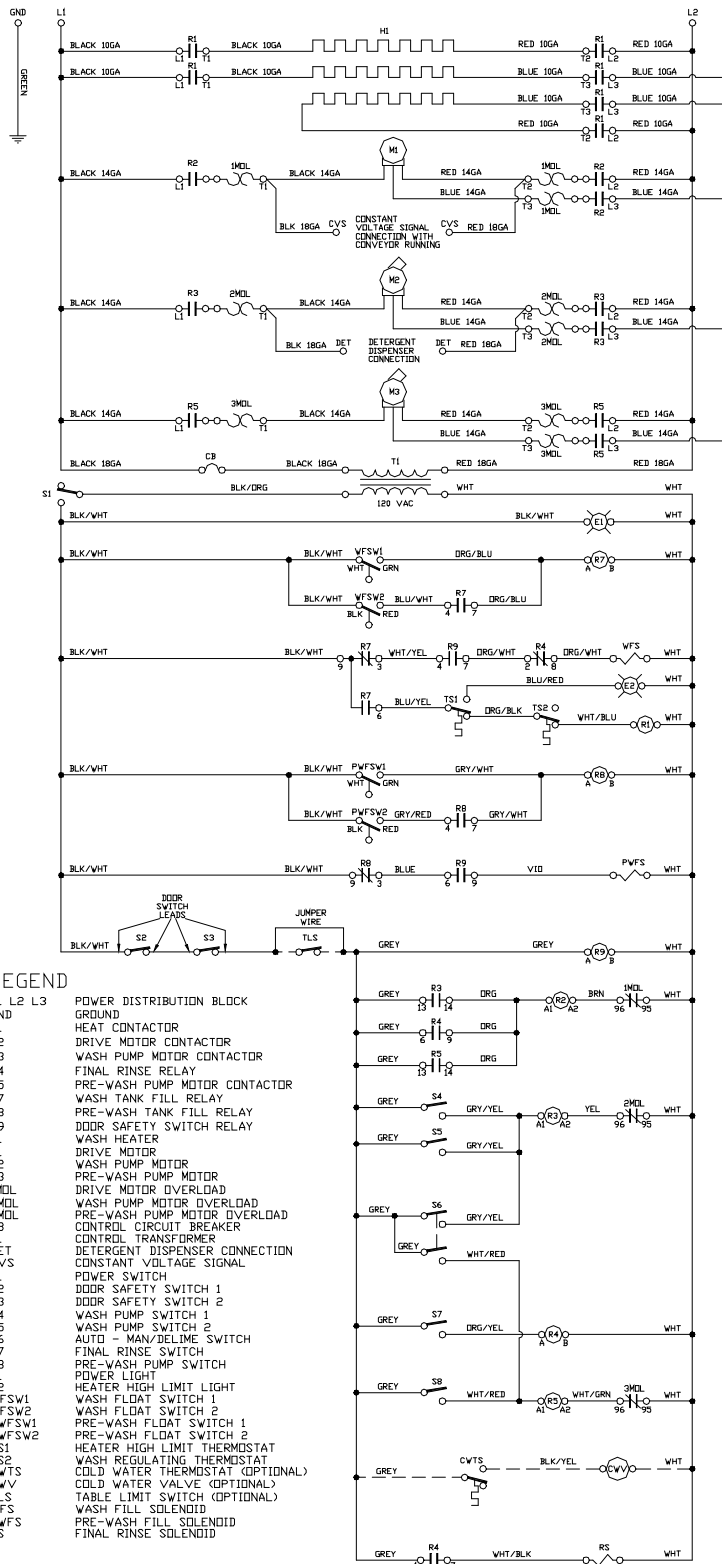

9905-031-70-76d

SECTION 6: ELECTRICAL SCHEMATICS

AJ-66TE & AJ-80TE (208-230 VOLT/60 HZ/3 PHASE)

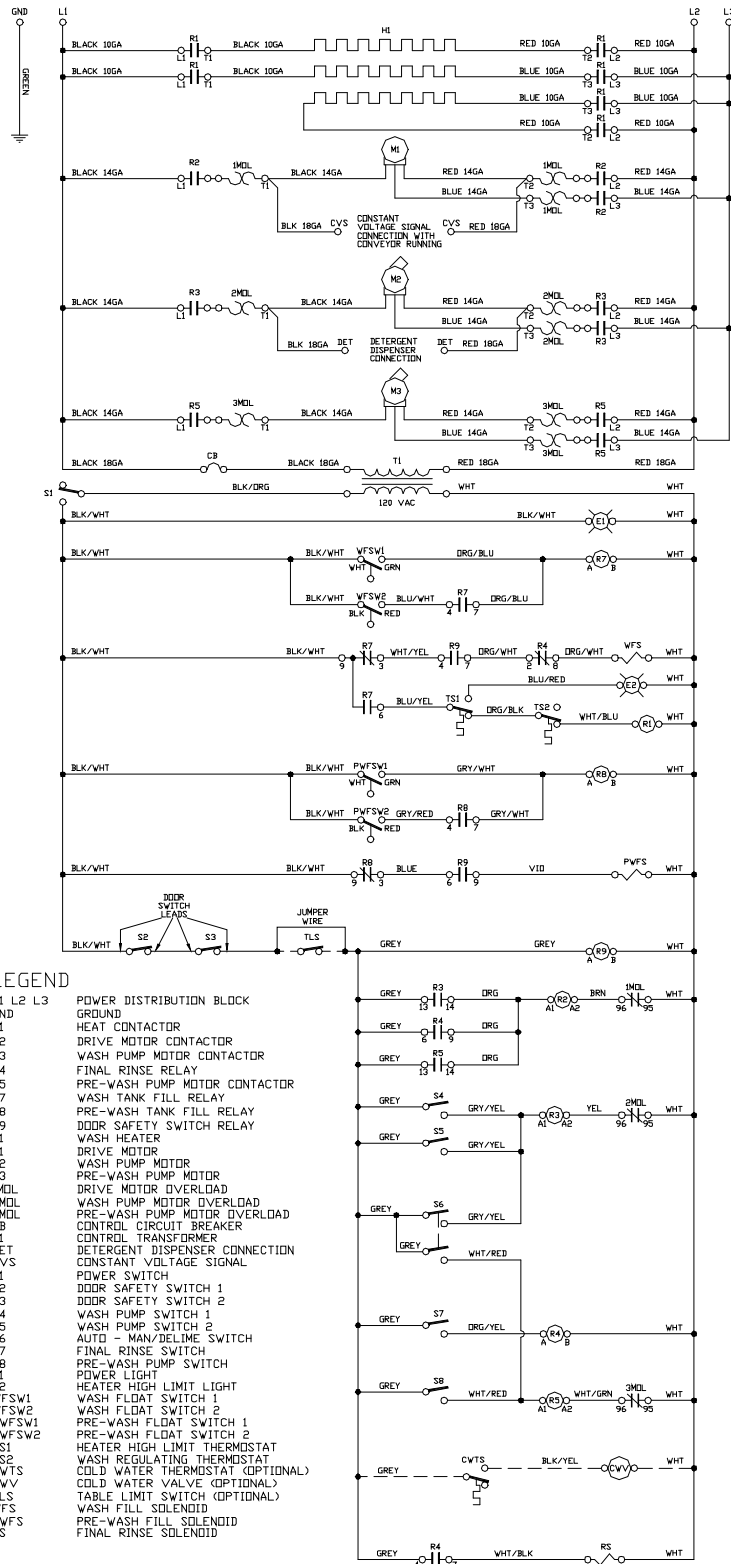

LEGEND

- L1 L2 L3 POWER DISTRIBUTION BLOCK
- GND GROUND
- R1 HEAT CONTACTOR
- R2 DRIVE MOTOR CONTACTOR
- R3 WASH PUMP MOTOR CONTACTOR
- R4 FINAL RINSE RELAY
- R5 PRE-WASH PUMP MOTOR CONTACTOR
- R7 WASH TANK FILL RELAY
- R8 PRE-WASH TANK FILL RELAY
- R9 DDR SAFETY SWITCH RELAY
- H1 WASH HEATER
- M1 DRIVE MOTOR
- M2 WASH PUMP MOTOR
- M3 PRE-WASH PUMP MOTOR
- 1MOL DRIVE MOTOR OVERLOAD
- 2MOL WASH PUMP MOTOR OVERLOAD
- 3MOL PRE-WASH PUMP MOTOR OVERLOAD
- CB CONTROL CIRCUIT BREAKER
- T1 CONTROL TRANSFORMER
- DET DETERGENT DISPENSER CONNECTION
- CVS CONSTANT VOLTAGE SIGNAL
- S1 POWER SWITCH
- S2 DDR SAFETY SWITCH 1
- S3 DDR SAFETY SWITCH 2
- S4 WASH PUMP SWITCH 1
- S5 WASH PUMP SWITCH 2
- S6 AUTO - MAN/DELIME SWITCH
- S7 FINAL RINSE SWITCH
- S8 PRE-WASH PUMP SWITCH
- E1 POWER LIGHT
- E2 HEATER HIGH LIMIT LIGHT
- WFSW1 WASH FLDAT SWITCH 1
- WFSW2 WASH FLDAT SWITCH 2
- PWFSW1 PRE-WASH FLDAT SWITCH 1
- PWFSW2 PRE-WASH FLDAT SWITCH 2
- TS1 HEATER HIGH LIMIT THERMISTAT
- TS2 WASH REGULATING THERMISTAT
- CWTS COLD WATER THERMISTAT (OPTIONAL)
- CVV COLD WATER VALVE (OPTIONAL)
- TLS TABLE LIMIT SWITCH (OPTIONAL)
- WFS WASH FILL SOLENOID
- PWFS PRE-WASH FILL SOLENOID
- RS FINAL RINSE SOLENOID

9905-031-70-76d

SECTION 6: ELECTRICAL SCHEMATICS

AJ-66TE & AJ-80TE (460 VOLT/60 HZ/3 PHASE)

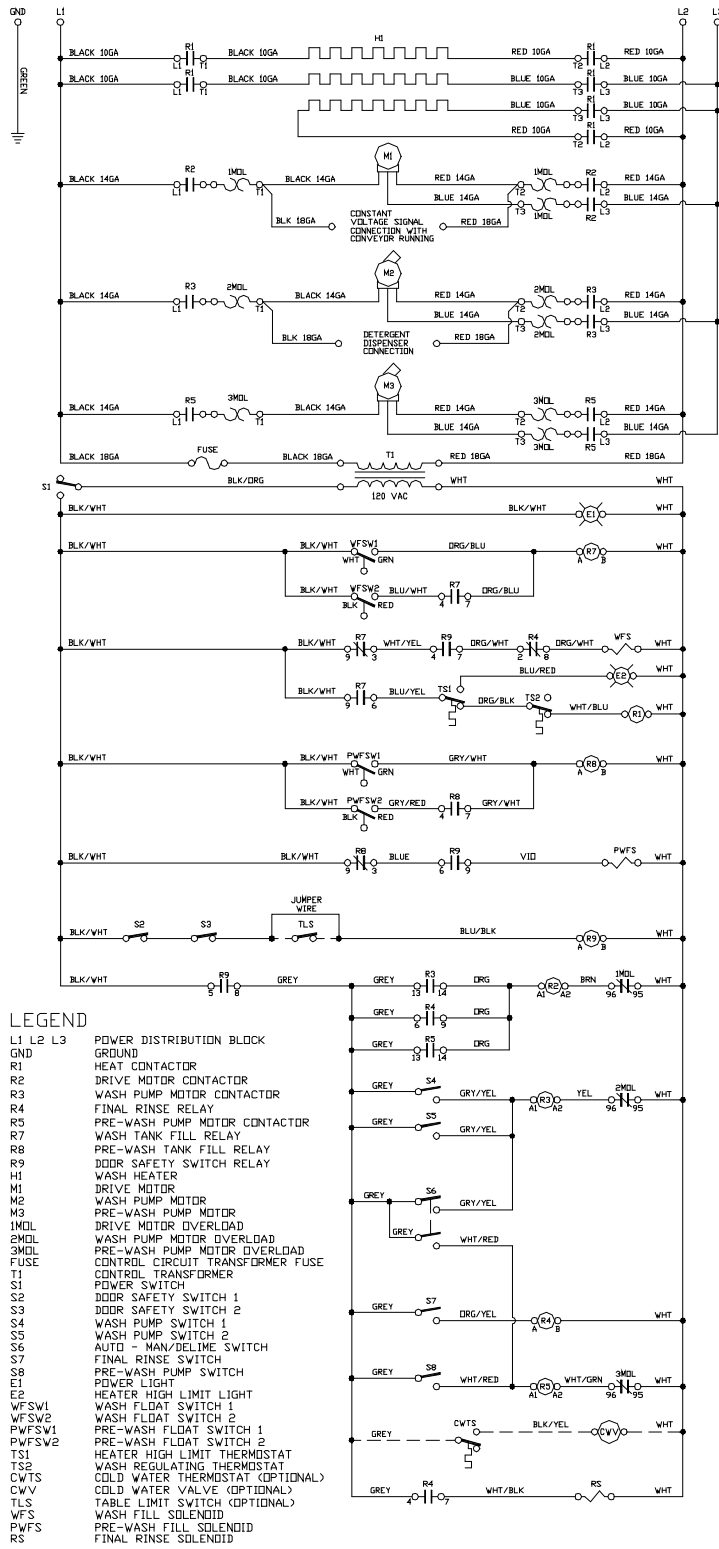

9905-031-72-92c

SECTION 6: ELECTRICAL SCHEMATICS

AJ-66TG & AJ-80TG (208-230 VOLTS/60 HZ/1 PHASE)

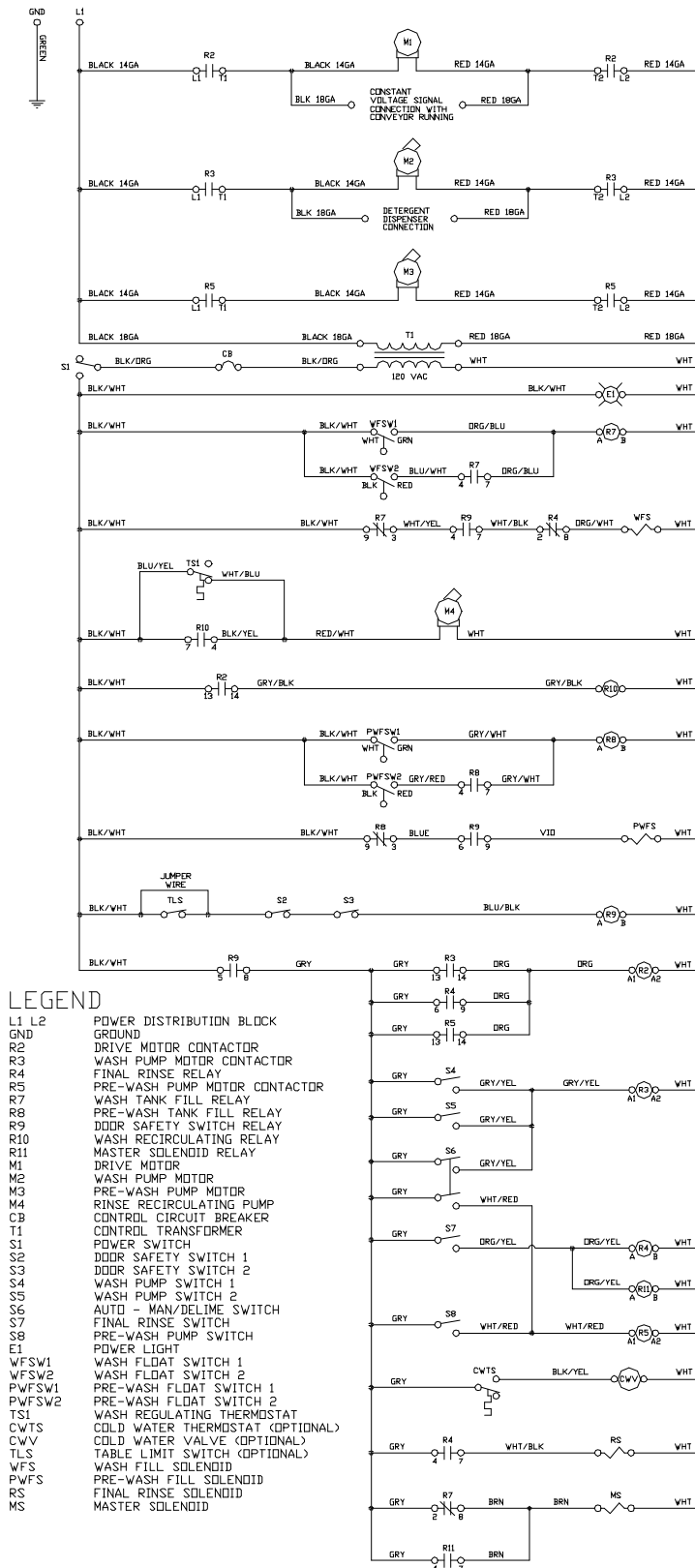

9905-002-53-26

SECTION 6: ELECTRICAL SCHEMATICS

AJ-66TG & AJ-80TG (208-230 VOLTS/60 HZ/3 PHASE)

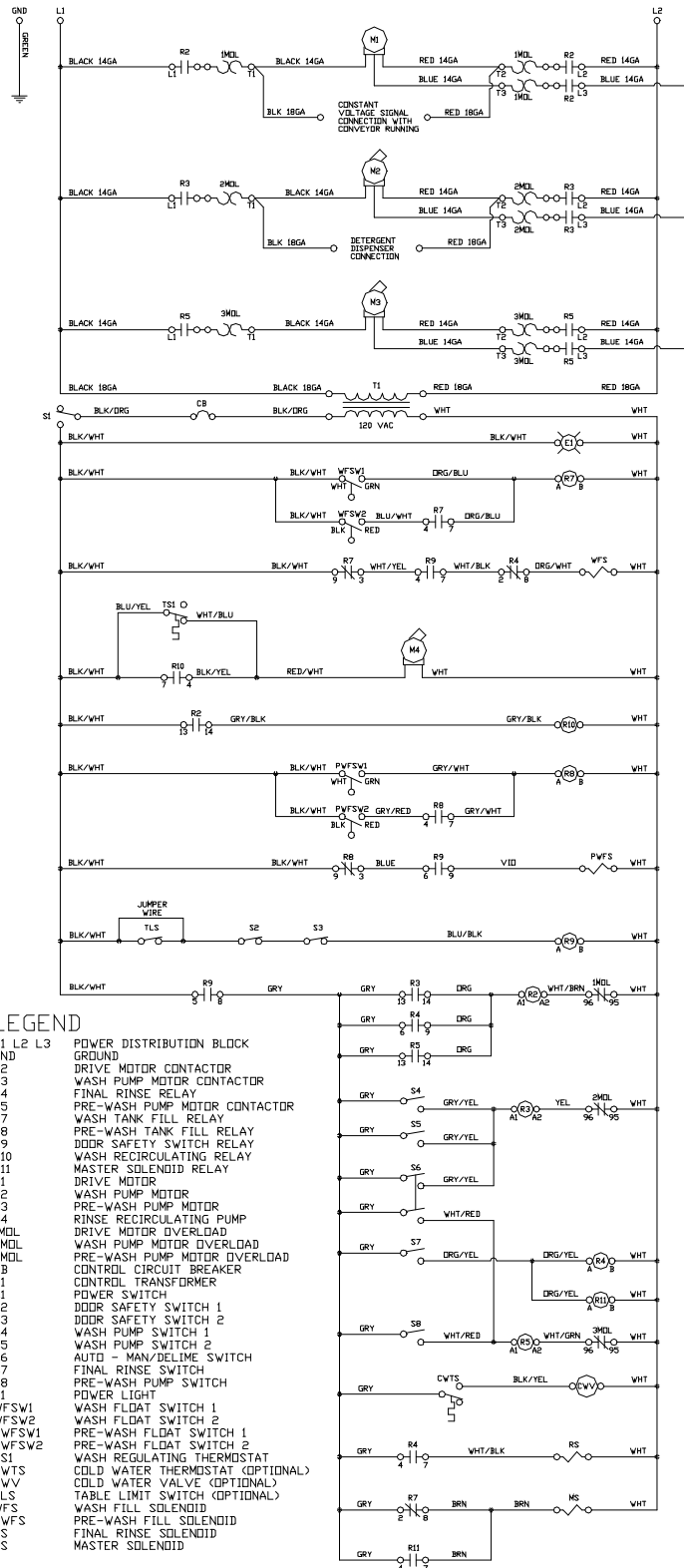

9905-002-33-61c

SECTION 6: ELECTRICAL SCHEMATICS

AJ-66T & AJ-80TG (460 VOLTS/60 HZ/3 PHASE)

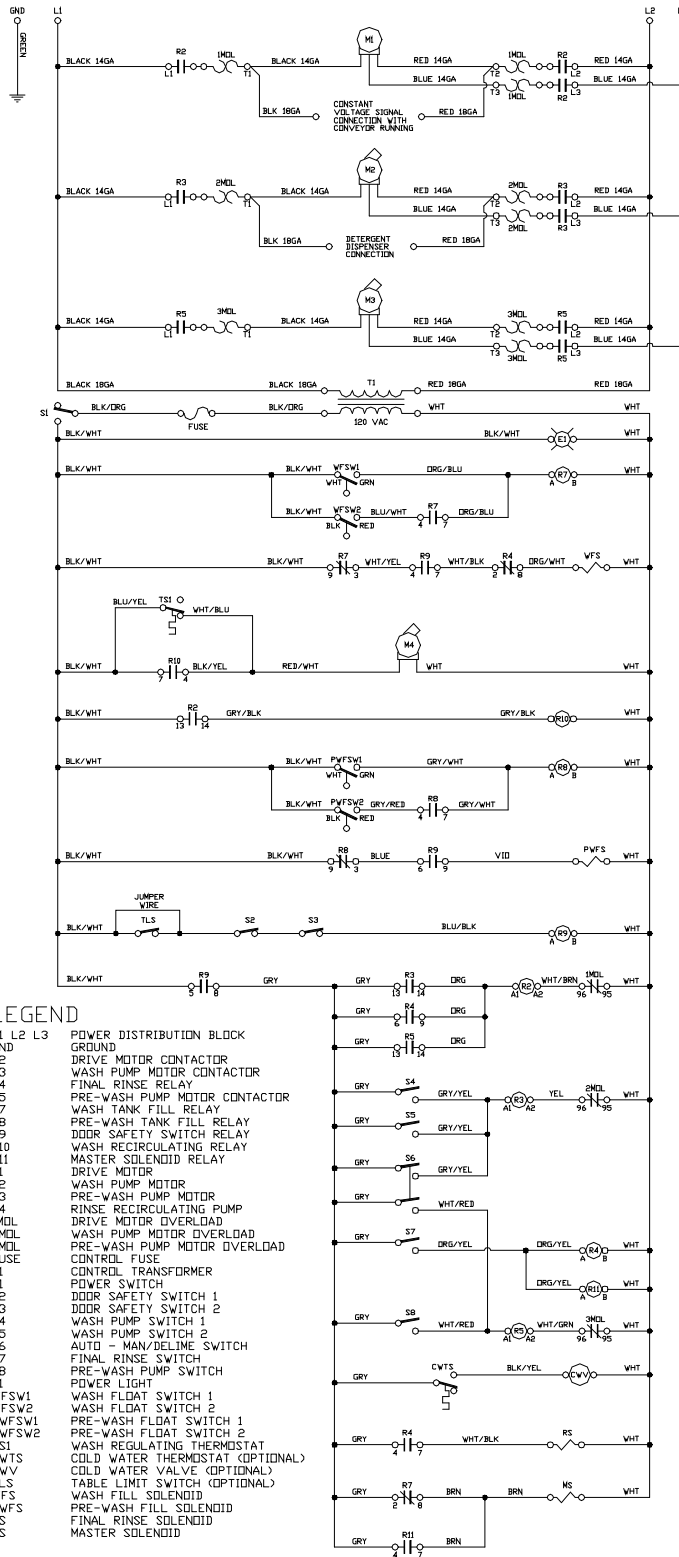

9905-002-53-25

SECTION 6: ELECTRICAL SCHEMATICS

AJ-66TS & AJ-80TS (208-230 VOLT/60 HZ/1 PHASE)

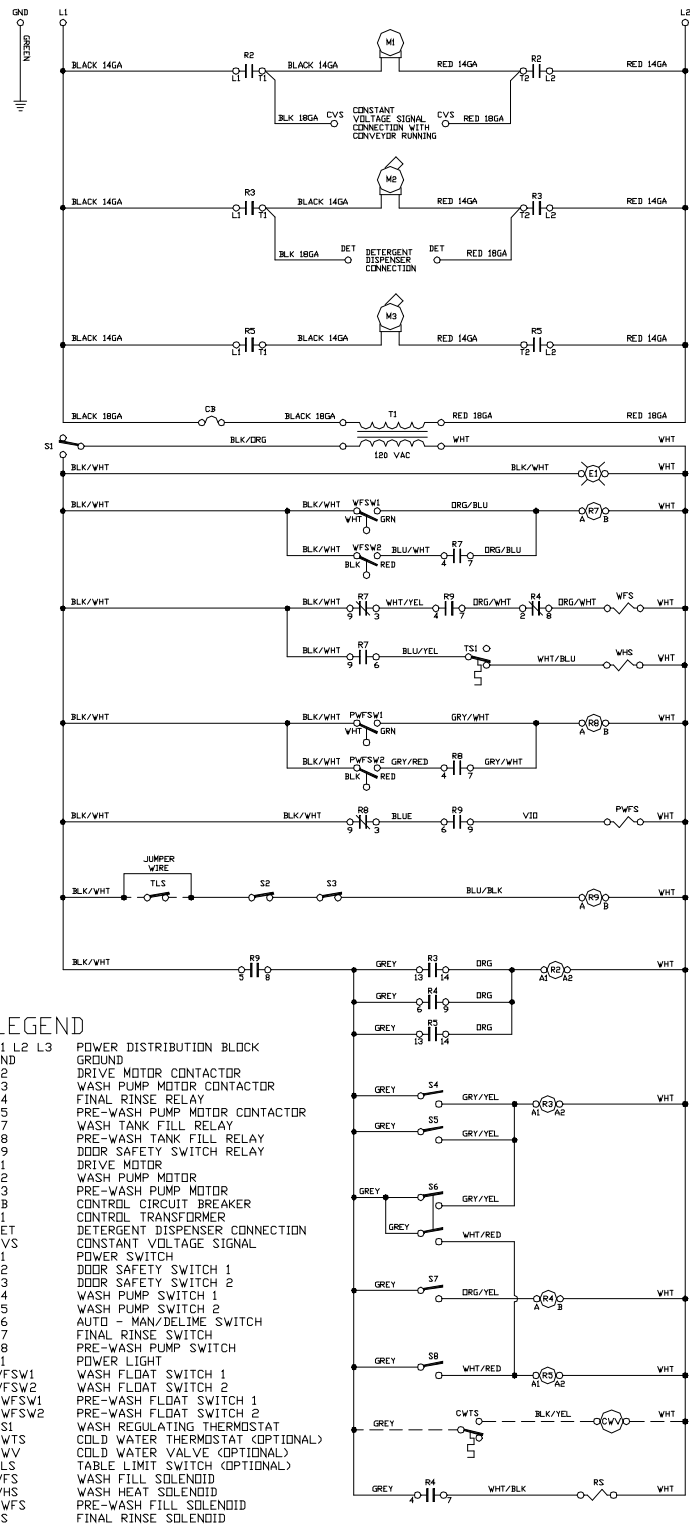

9905-002-37-15

SECTION 6: ELECTRICAL SCHEMATICS

AJ-66TS & AJ-80TS (208-230 VOLT/60 HZ/3 PHASE)

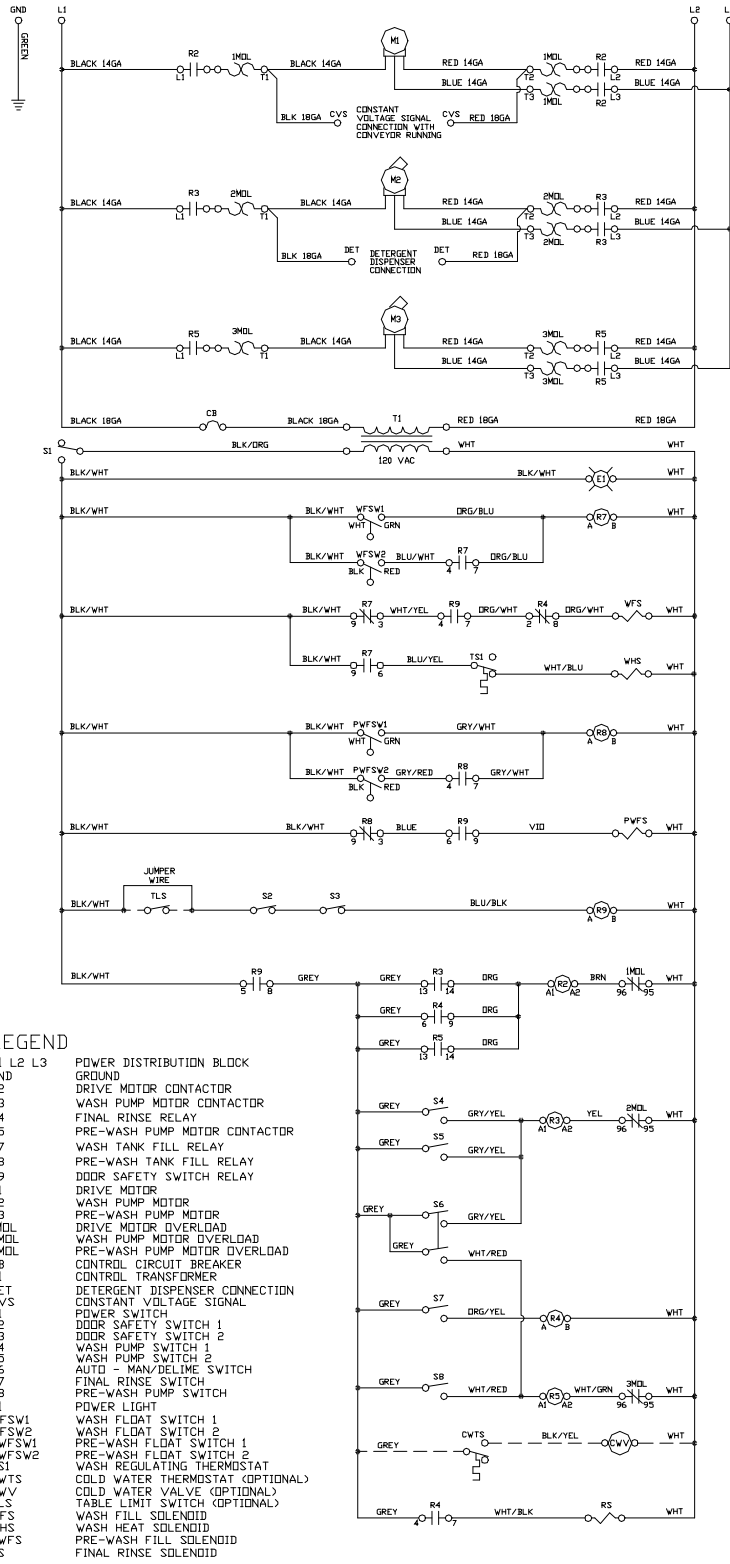

SECTION 6: ELECTRICAL SCHEMATICS

AJ-66TS & AJ-80TS (460 VOLT/60 HZ/3 PHASE)

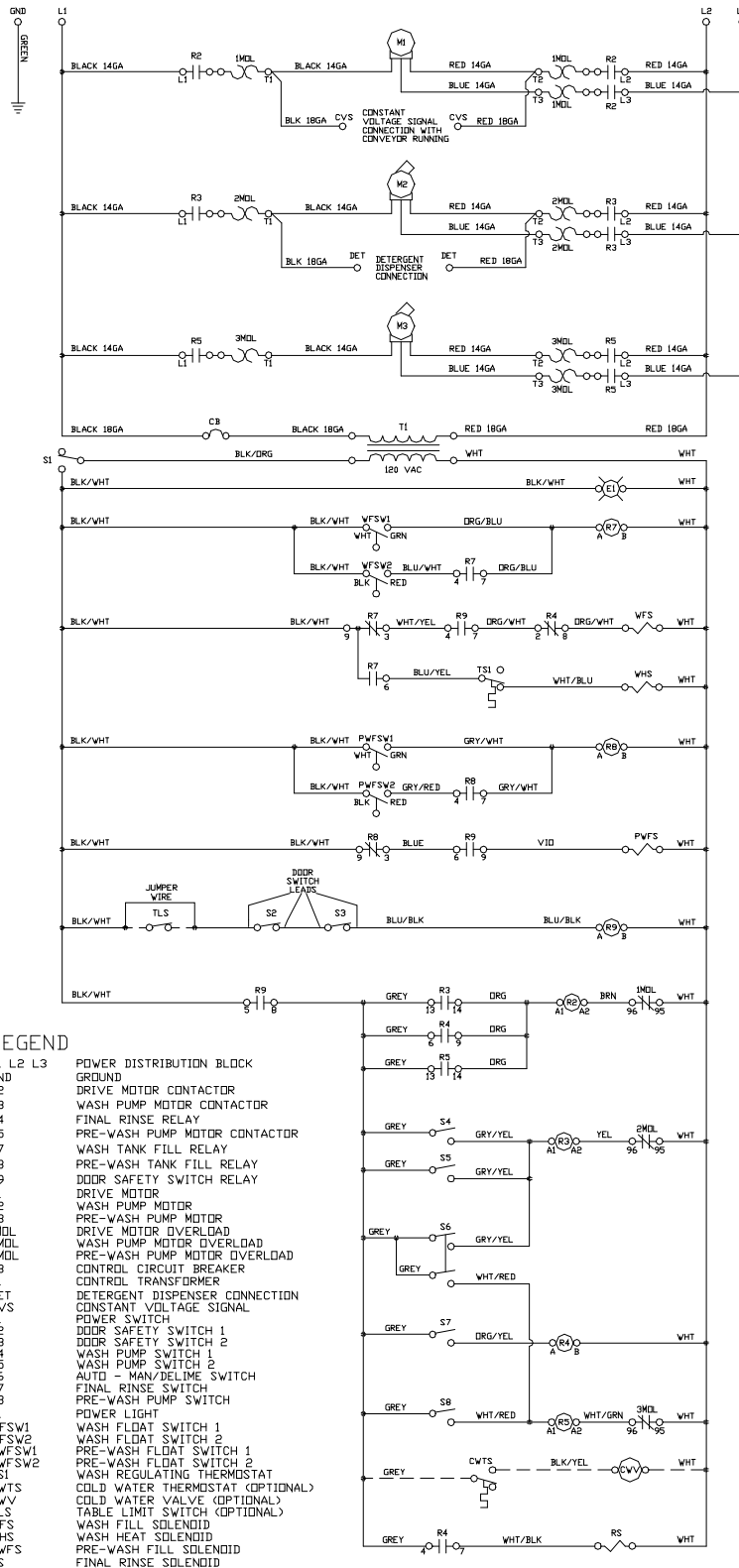

LEGEND

- L1 L2 L3 POWER DISTRIBUTION BLOCK
- GND GROUND
- R2 DRIVE MOTOR CONTACTOR
- R3 WASH PUMP MOTOR CONTACTOR
- R4 FINAL RINSE RELAY
- R5 PRE-WASH PUMP MOTOR CONTACTOR
- R7 WASH TANK FILL RELAY
- R8 PRE-WASH TANK FILL RELAY
- R9 DDDR SAFETY SWITCH RELAY
- M1 DRIVE MOTOR
- M2 WASH PUMP MOTOR
- M3 PRE-WASH PUMP MOTOR
- IMDL DRIVE MOTOR OVERLOAD
- 2MDL WASH PUMP MOTOR OVERLOAD
- 3MDL PRE-WASH PUMP MOTOR OVERLOAD
- CB CONTROL CIRCUIT BREAKER
- T1 CONTROL TRANSFORMER
- DET DETERGENT DISPENSER CONNECTION
- CVS CONSTANT VOLTAGE SIGNAL
- S1 POWER SWITCH
- S2 DDDR SAFETY SWITCH 1
- S3 DDDR SAFETY SWITCH 2
- S4 WASH PUMP SWITCH 1
- S5 WASH PUMP SWITCH 2
- S6 AUTO - MAN/DELTIME SWITCH
- S7 FINAL RINSE SWITCH
- S8 PRE-WASH PUMP SWITCH
- E1 POWER LIGHT
- WFSW1 WASH FLDAT SWITCH 1
- WFSW2 WASH FLDAT SWITCH 2
- PWFSW1 PRE-WASH FLDAT SWITCH 1
- PWFSW2 PRE-WASH FLDAT SWITCH 2
- TS1 WASH REGULATING THERMOSTAT
- CWVS COLD WATER THERMOSTAT (OPTIONAL)
- CVV COLD WATER VALVE (OPTIONAL)
- TLS TABLE LIMIT SWITCH (OPTIONAL)
- WFS WASH FILL SOLENOID
- WHS WASH HEAT SOLENOID
- PWFS PRE-WASH FILL SOLENOID
- RS FINAL RINSE SOLENOID

9905-031-80-28

SECTION 6: ELECTRICAL SCHEMATICS
CONVEYOR SIDE LOADER & DRAIN QUENCH DIAGRAM

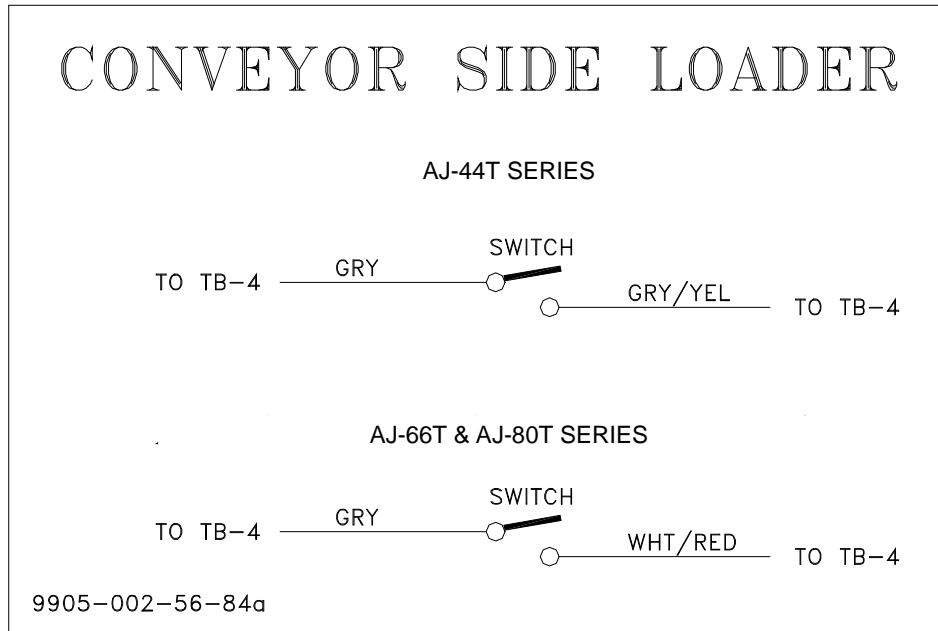

DRAIN QUENCH SCHEMATIC

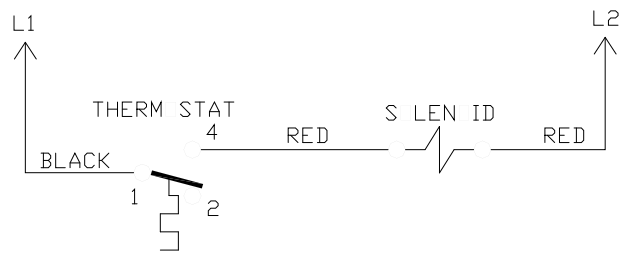

CONNECT BLACK WIRE TO MOTOR CONTACTOR - L1 WITH PIGGYBACK TERMINAL PROVIDED
 CONNECT WHITE WIRE TO MOTOR CONTACTOR - L2 WITH PIGGYBACK TERMINAL PROVIDED

SECTION 6: ELECTRICAL SCHEMATICS

EXHAUST FAN HOOK-UP SCHEMATIC

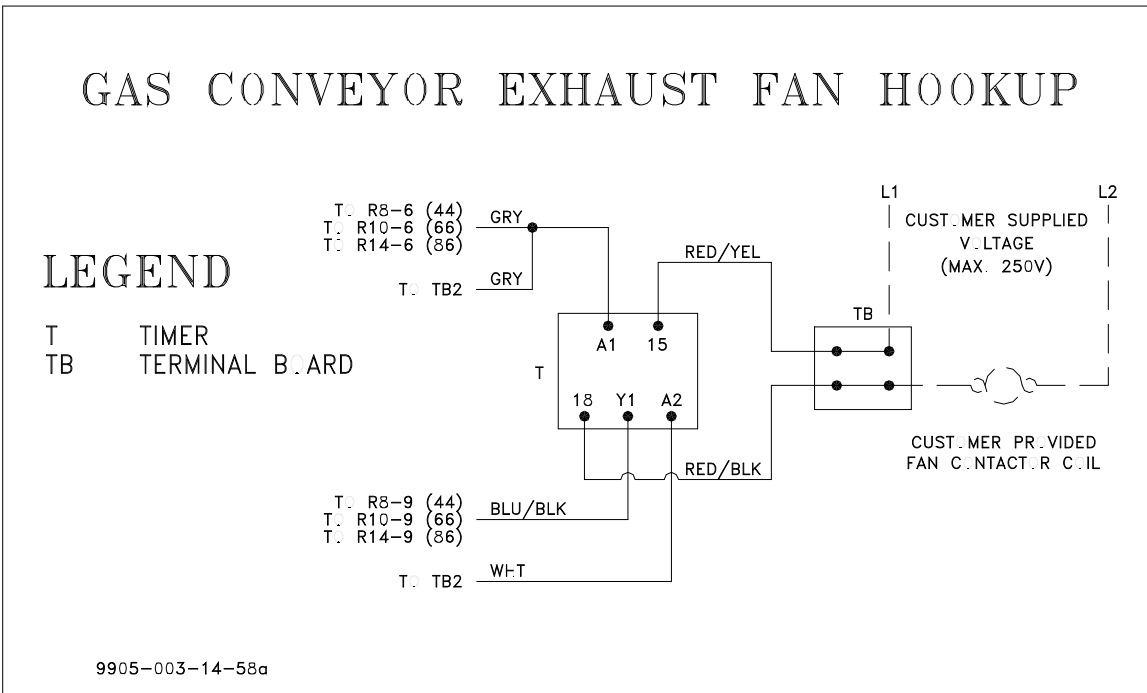
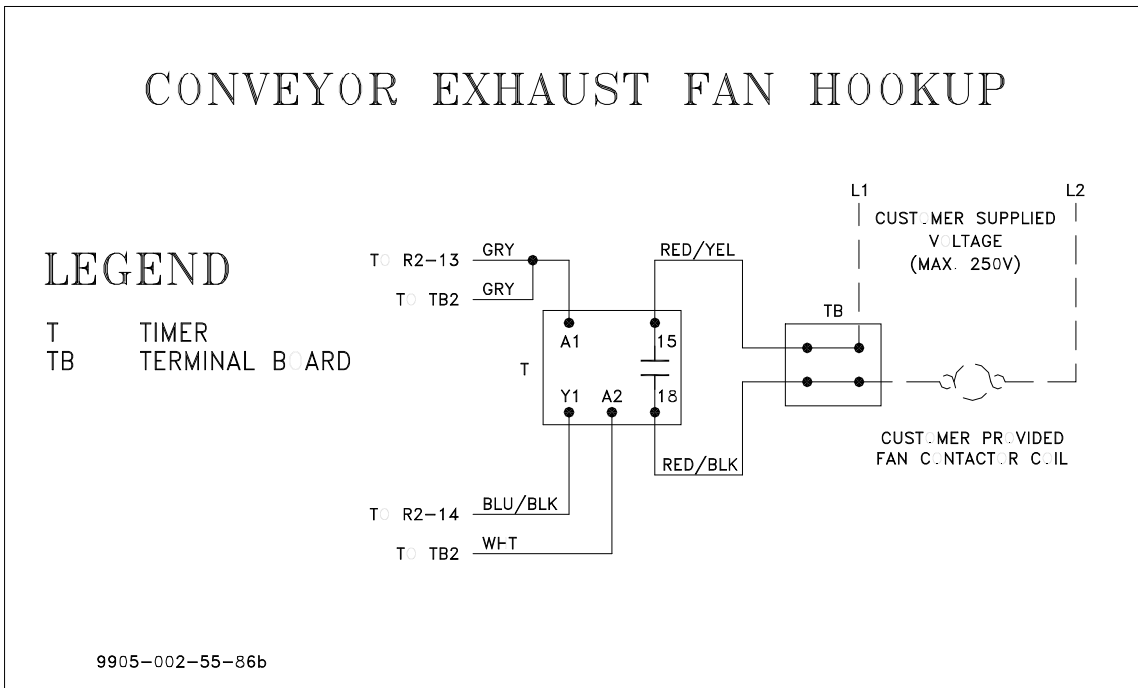

**SECTION 7:
JACKSON MAINTENANCE &
REPAIR CENTERS**

SECTION 7: JACKSON MAINTENANCE & REPAIR CENTERS

ALABAMA TO FLORIDA

ALABAMA

JONES-McLEOD APPLIANCE SVC

1616 7TH AVE. NORTH
BIRMINGHAM, AL 35203
(205) 251-0159
800-821-1150
FAX: (205) 322-1440
service@jones-mcleod.com

JONES-McLEOD APPLIANCE SVC

854 LAKESIDE DRIVE
MOBILE, AL 36693
(251) 666-7278
800-237-9859
FAX: (251) 661-0223

ALASKA

RESTAURANT APPLIANCE SERVICE

7219 ROOSEVELT WAY NE
SEATTLE, WA 98115
(206) 524-8200
800-433-9390
FAX: (206) 525-2890
info@restappl.com

ARIZONA

AUTHORIZED COMMERCIAL FOOD EQMT. SVC

4832 SOUTH 35TH STREET
PHOENIX, AZ 85040
(602) 234-2443
800-824-8875
FAX: (602) 232-5862
acsboss@aol.com

GCS SERVICE INC.

PHOENIX, AZ
(602) 474-4510
800-510-3497
FAX: (602) 470-4511

ARKANSAS

BROMLEY PARTS & SVC

10TH AND RINGO
P.O. BOX 1688
LITTLE ROCK, AR 72202
(501) 374-0281
800-482-9269
FAX: (501) 374-8352
service@bromleyparts.com
parts@bromleyparts.com

GCS SERVICE, INC.

3717 CHERRY ROAD
MEMPHIS, TN 38118
(901) 366-4587
800-262-9155
FAX: (901) 366-4588

CALIFORNIA

BARKERS FOOD MACHINERY SERVICES

5367 SECOND STREET
IRWINDALE, CA 91706
(626) 960-9390
800-258-6999
FAX: (626) 337-4541
service@barkers.com

GCS SERVICE INC.

LOS ANGELES, CA
(213) 683-2090
800-327-1433
FAX: (213) 683-2099

GCS SERVICE INC.

SANTA ANA, CA
(714) 542-1798
800-540-0719
FAX: (714) 542-4787

GCS SERVICE INC.

S. SAN FRANCISCO, CA
(650) 635-0720
800-969-4427
FAX: (650) 871-4019

COMMERCIAL APPLIANCE SERVICE, INC.

6507 PACIFIC AVENUE, SUITE 102
STOCKTON, CA 95207
(916) 567-0203
(800) 464-2222
(916) 567-0266 FAX

GCS SERVICE INC.

SAN DIEGO, CA
(858) 549-8411
800-422-7278
FAX: (858) 549-2323

INDUSTRIAL ELECTRIC SVC.

5662 ENGINEER DRIVE
HUNTINGTON BEACH, CA 92649
(714) 379-7100
(800-457-3783
FAX: (714) 379-7109

P & D APPLIANCE SVC

100 SOUTH LINDEN AVE.
S. SAN FRANCISCO, CA 94080
(650) 635-1900
800-424-1414
FAX: (650) 635-1919
pndappl@aol.com

P & D APPLIANCE

4220-C ROSEVILLE ROAD
NORTH HIGHLANDS, CA 95660
(916) 974-2772
800-824-7219
FAX: (916) 974-2774

COMMERCIAL APPLIANCE SERVICE, INC.

281 LATHROP WAY, #100
SACRAMENTO, CA 95815
(916) 567-0203
(800) 464-2222
(916) 567-0324 FAX

COLORADO

GCS SERVICE INC.

SHERIDAN, CO
(303) 371-9054
800-972-5314
FAX: (303) 371-4754

HAWKINS COMMERCIAL APPLIANCE SERVICE

3000 S. WYANDOT ST.
ENGLEWOOD, CO 80110
(303) 781-5548
(800) 624-2117
FAX: (303) 761-5561
johns@hawkinscommercial.com

METRO APPLIANCE SERVICE

1640 S BROADWAY
DENVER, CO 80210
(303) 778-1126
800-525-3532
FAX: (303) 778-0268
metroappls@aol.com

CONNECTICUT

GCS SERVICE INC.

HARTFORD, CT
(860) 549-5575
800-423-1562
FAX: (860) 527-6355

SUPERIOR KITCHEN SERVICE INC.

22 THOMPSON ROAD
WINDSOR, CT 06088
(888) 590-1899
(888) 590-1996 FAX

DELAWARE

FOOD SERVICE EQMT.

2101 PARKWAY SOUTH
BROOMALL, PA 19008
(610) 356-6900
FAX: (610) 356-2038
dancerule@aol.com

GCS SERVICE INC.

PHILADELPHIA, PA
(215)925-6217
800-441-9115
FAX: (215) 925-6208

ELMER SCHULTZ SERVICE

36 BELMONT AVE.
WILLMINGTON, DE 19804
(302) 655-8900
800-225-0599
FAX: (302) 656-3673
elmer2@erols.com

EMR SERVICE DIVISION

106 WILLIAMSPORT CIRCLE
SALISBURY, MD 21804
(410) 543-8197
FAX: (410) 548-4038

FLORIDA

COMMERCIAL APPLIANCE SERVICE

8416 LAUREL FAIR CIRCLE
BLDG 6, SUITE 114
TAMPA, FL 33610
(813) 663-0313
800-282-4718
FAX: (813) 663-0212
commercialappliance@world-net.att.net

GCS SERVICE INC

MIAMI, FL
(305) 621-6666
800-766-8966
FAX: (305) 621-6656

GCS SERVICE INC

ORLANDO, FL
(407) 841-2551
800-338-7322
FAX: (407) 423-8425

NASS PARTS AND SERVICE, INC.

1144 BELVILLE ROAD, UNIT 359
DAYTONA BEACH, FL 32114
(386) 226-2642
(800) 432-2795
(386) 736-7695 FAX

GCS SERVICE INC

TAMPA, FL
(813) 626-6044
800-282-3008
FAX: (813) 621-1174

SECTION 7: JACKSON MAINTENANCE & REPAIR CENTERS

FLORIDA TO MARYLAND

JONES-McLEOD APPLIANCE SVC

854 LAKESIDE DRIVE
MOBILE, AL 36693
(251) 666-7278
800-237-9859
FAX: (251) 661-0223
service@jones-mcleod.com

NASS PARTS AND SERVICE, INC.

1108 SOUTH WOODS AVENUE
ORLANDO, FL 32805
(407) 425-2681
(800) 432-2795
(407) 425-3463 FAX

NASS PARTS AND SERVICE, INC.

1376 HEIDE AVENUE
PALM BAY, FL 32907
(321) 952-2012
(800) 432-2795
(321) 953-0266 FAX

GEORGIA

GCS SERVICE INC

ATLANTA, GA
(770) 452-7322
800-334-3599
FAX: (770) 452-7473

HERITAGE FOODSERVICE

GROUP OF ATLANTA
2100 NORCROSS PKWY.
SUITE 130
NORCROSS, GA 30071
(770) 368-1465
866-388-9837
FAX: (866) 388-9838

WHALEY FOODSERVICE REPAIRS

109-A OWENS INDUSTRIAL DRIVE
SAVANNAH, GA 31405
(912) 447-0827
888-765-0036
FAX: (912) 447-0826

PIERCE PARTS & SERVICE

2422 ALLEN ROAD
MACON, GA 31216
(478) 781-6003
800-368-2512
FAX: (478) 781-7186

HAWAII

FOOD EQMT. PARTS & SERVICE CO.

300 PUUHALE RD.
HONOLULU, HI 96819
(808) 847-4871
FAX: (808) 842-1560
fepsco@hula.net

IDAHO

RESTAURANT APPLIANCE SVC.

7219 ROOSEVELT WAY NE
SEATTLE, WA 98115
(206) 524-8200
800-433-9390
FAX: (206) 525-2890
info@restappl.com

RON'S SERVICE

703 E 44TH STREET STE 10
GARDEN CITY, ID 83714
(208) 375-4073
FAX: (208) 375-4402

ILLINOIS

CONES REPAIR SVC.

2408 40TH AVE.
MOLINE, IL 61265
(309) 797-5323
800-716-7070
FAX: (309) 797-3631
jackb@cones.com

EICHENAUER SERVICES INC.

130 S OAKLAND ST.
DECATUR, IL 62522
(217) 429-4229
800-252-5892
FAX: (217) 429-0226
esi@esiquality.com

GCS SERVICE INC.

ELMHURST, IL
(630) 941-7800
800-942-9689
FAX: (630) 941-6048

GCS SERVICE INC.

ST. LOUIS, MO
(314) 683-7444
800-284-4427
FAX: (314) 638-0135

GENERAL PARTS, INC.

248 JAMES STREET
BENSONVILLE, IL 60106
(630) 595-3300
(800) 880-3604
FAX: (630) 595-0006

INDIANA

GCS SERVICE INC.

INDIANAPOLIS, IN
(317) 545-9655
800-727-8710
FAX: (317) 549-6286

B622 LA PAS TRAIL

INDIANAPOLIS, IN 46268
(317) 290-8060
(800) 410-9794
(317) 290-8085 FAX

IOWA

GOODWIN TUCKER GROUP

2900 DELAWARE AVENUE

DES MOINES, IA 50317
(515) 262-9308
800-372-6066
FAX: (515) 262-2936
parts@goodwintucker.com

CONES REPAIR SVC.

1056 27TH AVENUE SW
CEDAR RAPIDS, IA 52404
(319) 365-3325
800-747-3326
FAX: (319) 365-0885

KANSAS

GCS SERVICE INC.

KANSAS CITY, MO
(816) 920-5999
800-229-6477
FAX: (816) 920-7387

GENERAL PARTS, INC.

1101 E. 13TH STREET
KANSAS CITY, MO 64106
(816) 421-5400
(800) 279-9967
(816) 421-1270 FAX

KENTUCKY

CERTIFIED SERVICE CENTER

127 DISHMAN LANE
BOWLING GREEN, KY 42101
(270) 783-0012
(877) 907-0012
FAX: (270) 783-0058

CERTIFIED SERVICE CENTER

RAMCO BUSINESS PARK

4283 PRODUCE ROAD
LOUISVILLE, KY 40218
(502) 964-7007
800-637-6350
FAX: (502) 964-7202
cwalker@certifiedsc.com
droenigk@certifiedsc.com

CERTIFIED SERVICE CENTER

1051 GOODWIN DRIVE
LEXINGTON, KY 40505
(606) 254-8854
800-432-9269
FAX: (606) 231-7781
jatkens@certifiedsc.com

GCS SERVICE INC.

LOUISVILLE, KY
(502) 367-1788
800-752-6160
FAX: (502) 367-0400

GCS SERVICE INC.

LEXINGTON, KY
(606) 255-0746
800-432-9260
FAX: (606) 255-0748

LOUISIANA

HERITAGE SERVICE GROUP

1532 RIVER OAKS WEST
NEW ORLEANS, LA 70123
(504) 734-8864
(800) 499-2351
(504) 733-2559 FAX

MAINE

GCS SERVICE INC.

CHELSEA, MA
(617) 889-9393
800-225-1155
FAX: (617) 889-1222

MASSACHUSETTS RESTAU-

RANT SUPPLY

34 SOUTH STREET
SOMERVILLE, MA 02143
(617) 868-1930
800-338-6737
FAX: (617) 686-5331

PINE TREE FOOD EQUIP- MENT

175 LEWISTON ROAD
GRAY, ME 04039
(207) 657-6400
(800) 540-5427
(207) 657-5464 FAX

MARYLAND

EMR SERVICE DIVISION

700 EAST 25TH STREET
BALTIMORE, MD 21218
(410) 467-8080
800-879-4994
FAX: (410) 467-4191
baltparts@emrco.com

SECTION 7: JACKSON MAINTENANCE & REPAIR CENTERS

MARYLAND TO NEW YORK

EMR SERVICE DIVISION
106 WILLIAMSPORT CIRCLE
SALISBURY, MD 21804
(410) 543-8197
888-687-8080
FAX: (410) 548-4038
baltparts@emrco.com

EMR SERVICE DIVISION
5316 Sunnyside Ave.
Beltsville, MD 20715
(301) 931-7000
800-348-2365
FAX: (301) 931-3060
baltparts@emrco.com

GCS SERVICE INC.
SILVER SPRING, MD
(301) 585-7550 (DC)
(410) 792-0338 (BALT)
(800) 638-7278
FAX: (301) 495-4410

MASSACHUSETTS

ACE SERVICE CO.
95 HAMPTON AVE.
NEEDHAM, MA 02494
(781) 449-4220
800-225-4510 MA & NH
FAX: (781) 444-4789
taceservice@aol.com

**MASSACHUSETTS RESTAU-
RANT SUPPLY**
34 SOUTH STREET
SOMERVILLE, MA 02143
(617) 868-1930
800-338-6737
FAX: (617) 868-5331

GCS SERVICE INC.
CHELSEA, MA
(617) 889-9393
800-225-1155
FAX: (617) 889-1222

GCS SERVICE INC.
HARTFORD, CT
(860) 549-5575
800-723-1562
FAX: (860) 527-6355

**SUPERIOR KITCHEN SER-
VICE INC.**
399 FERRY STREET
EVERETT, MA 02149
(617) 389-1899
(888) 590-1899
(617) 389-1996 FAX

MICHIGAN

GCS SERVICE INC.
LIVONIA, MI
(248) 426-9500
800-772-2936
FAX: (248) 426-7555

**JACKSON SERVICE COMPA-
NY**
3980 BENSTEIN RD.
COMMERCE TWSHP, MI 48382
(248) 363-4159
800-332-4053
FAX: (248) 363-5448

GCS SERVICE INC.
GRAND RAPIDS, MI
(616) 241-0200
800-823-4866
FAX: (616) 241-0541

MINNESOTA

GCS SERVICE INC.
MINNEAPOLIS, MN
(612) 546-4221
800-345-4221
FAX: (612) 546-4286

GENERAL PARTS, INC.
11311 HAMPSHIRE AVENUE
SOUTH
BLOOMINGTON, MN 55438-
2456
(952) 944-5800
(800) 279-9980
(800) 279-9980 FAX

MISSISSIPPI

GCS SERVICE INC.
JACKSON, MS
(601) 956-7800
800-274-5954
FAX: (601) 956-1200

GCS SERVICE INC.
MEMPHIS, TN
(901) 366-4587
800-262-9155
FAX: (901) 366-4588

MISSOURI

GCS SERVICE INC.
KANSAS CITY, MO
(816) 920-5999
800-229-6477
FAX: (816) 920-7387

GCS SERVICE INC.
ST. LOUIS, MO
(314) 638-7444
800-284-4427
FAX: (314) 638-0135

KAEMMERLIN PARTS & SVC.
2728 LOCUST STREET
ST. LOUIS, MO 63103
(314) 535-2222
FAX: (314) 535-6205
petek@kps.stl.com

GENERAL PARTS, INC.
1101 EAST 13TH STREET
KANSAS CITY, MO 64106
(816) 421-5400
(800) 279-9967
(816) 421-1270 FAX

MONTANA

**RESTAURANT APPLIANCE
SVC.**
7219 ROOSEVELT WAY NE
SEATTLE, WA 98115
(206) 524-8200
800-433-9390
FAX: (206) 525-2890
info@restappl.com

NEBRASKA

GOODWIN - TUCKER GROUP
7535 D STREET
OMAHA, NE 68124
(402) 397-2880
800-228-0342
FAX: (402) 397-2881
askme@goodwintucker.com

NEVADA

**HI TECH COMMERCIAL SER-
VICE**
1840 STELLA LAKE STREET
NORTH LAS VEGAS, NV 89106
(702) 649-4616
(877) 924-4832
FAX: (702) 649-4607
larry@hitechnv.com

5454 LOUIE LANE
RENO, NV 89511
(775) 852-9696
FAX: (775) 852-5104

GCS SERVICE INC.
LAS VEGAS, NV
(702) 450-3495
800-500-9060
FAX: (702) 450-3491

NEW HAMPSHIRE

GCS SERVICE INC.
CHELSEA, MA
(617)889-9393
800-225-1155
FAX: (617) 889-1222

ACE SERVICE CO.
95 HAMPTON AVE.
NEEDHAM, MA 02494
(781) 449-4220
800-225-4510 MA & NH
FAX: (781) 444-4789
taceservice@aol.com

**MASSACHUSETTS RESTAU-
RANT SUPPLY**
34 SOUTH STREET
SOMERVILLE, MA 02143
(617) 868-1930
800-338-6737
FAX: (617) 868-5331

NEW JERSEY

JAY HILL REPAIRS
90 CLINTON RD.
FAIRFIELD, NJ 07004
(973) 575-9145
800-836-0643
FAX: (973) 575-5890
jhrepair@aol.com

GCS SERVICE INC.
EAST RUTHERFORD, NJ
(973) 614-0003
800-399-8294
FAX: (973) 614-0230

GCS SERVICE INC.
PHILADELPHIA, PA
(215) 925-6217
800-441-9115
FAX: (215) 925-6208

ELMER SCHULTZ SERVICES
201 W. WASHINGTON AVE.
PLEASANTVILLE, NJ 08232
(609) 641-0317
800-378-1641
FAX:(609) 641-8703
elmer2@erols.com

NEW YORK

**APPLIANCE INSTALLATION
AND SERVICE CORP.**
1336 MAIN STREET
BUFFALO, NY 14209
(716) 884-7425
800-722-1252
FAX: (716) 884-0410
ais@worldnet.att.net

SECTION 7: JACKSON MAINTENANCE & REPAIR CENTERS

NEW YORK TO PENNSYLVANIA

B.E.S.T. INC.

3003 GENESEE STREET
BUFFALO, NY 14225
(716) 893-6464
800-338-5011
FAX: (716) 893-6466
bestserv@aol.com

DUFFY'S EQUIPMENT SVC.

3138 ONEIDA STREET
SAUQUOIT, NY 13456
(315) 737-9401
800-443-8339
FAX: (315) 737-7132
duffyequip@aol.com

NORTHERN PARTS & SVC.

21 NORTHERN AVENUE
PLATTSBURGH, NY 12903
(518) 563-3200
800-634-5005
FAX: (800) 782-5424
info@northernparts.com

GCS SERVICE INC.

BROOKLYN, NY
(718) 486-5220
800-969-4271
FAX: (718) 486-6772

ALL SERVICE KITCHEN

EQUIPMENT REPAIR
10 CHARLES ST.
NEW HYDE PARK, NY 11040
(516) 378-1176
FAX: (516) 378-1735

ALL ISLAND REPAIRS

40-9 BURT DRIVE
DEER PARK, NY 11729
(631) 242-5588
FAX: (631) 242-6102

NORTH CAROLINA

AUTHORIZED APPLIANCE SERVICECENTER

1020 TUCKASEEGEE RD.
CHARLOTTE, NC 28208
(704) 377-4501
(800) 532-6127
FAX:(704) 377-4504

AUTHORIZED APPLIANCE SERVICECENTER

800 N. PERSON ST.
RALEIGH, NC 27604
(919) 834-3476
FAX:(919) 834-3477

AUTHORIZED APPLIANCE SERVICECENTER

904 S. MARSHALL ST.
WINSTON-SALEM, NC 27403
(336) 725-5396
FAX:(336) 721-1289

AUTHORIZED APPLIANCE SERVICECENTER

104 HINTON AVE.
WILMINGTON, NC 28403
(910) 313-1250
FAX:(910) 313-6130

WHALEY FOODSERVICE

8334-K ARROWRIDGE BLVD
CHARLOTTE, NC 28273
(704) 529-6242
FAX: (704) 529-1558
info@whaleyfoodservice.com

WHALEY FOODSERVICE REPAIRS

203-D CREEK RIDGE RD.
GREENSBORO, NC 27406
(336) 333-2333
FAX: (336) 333-2533
info@whaleyfoodservice.com

WHALEY FOODSERVICE REPAIRS

335-105 SHERWEE DRIVE
RALEIGH, NC 27603
(919) 779-2266
FAX: (919) 779-2224
info@whaleyfoodservice.com

WHALEY FOODSERVICE REPAIRS

6418-101 AMSTERDAM WAY
WILMINGTON, NC 28405
(910) 791-0000
FAX: (910) 791-6662
info@whaleyfoodservice.com

NORTH DAKOTA

GCS SERVICE INC.

MINNEAPOLIS, MN
(612) 546-4221
800-345-4221
FAX: (612) 546-4286

GENERAL PARTS, INC.

10 SOUTH 18TH STREET
FARGO, ND 58103
(701) 235-4161
(800) 279-9987
(701) 235-0539 FAX

OHIO

CERTIFIED SERVICE CENTER

890 REDNA TERRACE
CINCINNATI, OH 45215
(513) 772-6600
800-543-2060
FAX: (513) 612-6600
sbarasch@certifiedsc.com

CERTIFIED SERVICE CENTER

171J-K NORTH HAMILTON RD.
COLUMBUS, OH 43213
(614) 751-3769
(866) 862-1252
FAX: (614) 751-5792
jadkins@certifiedsc.com

CERTIFIED SERVICE CENTER

6025 N. DIXIE DRIVE
DAYTON, OH 45414
(937) 898-4040
(800) 257-2611
FAX: (937) 898-4177
dharvey@certifiedsc.com

COMMERCIAL PARTS & SVC. OF COLUMBUS

5033 TRANSAMERICA DRIVE
COLUMBUS, OH 43228
(614) 221-0057
800-837-8327
FAX: (614) 221-3622

GCS SERVICE INC.

COLUMBUS, OH
(614) 476-3225
800-282-5406
FAX: (614) 476-1196

ELECTRICAL APPLIANCE REPAIR SVC.

5805 VALLEY BELT ROAD
CLEVELAND, OH 44131
(216) 459-8700
800-621-8259
FAX: (216) 459-8707
tomr@electapprep.com

OKLAHOMA

HAGAR RESTAURANT EQMT.

1229 W MAIN STREET
OKLAHOMA CITY, OK 73106
(405) 235-2184
800-445-1791
FAX: (405) 236-5592

OREGON

RON'S SERVICE

16364 SW 72ND AVE
PORTLAND, OR 97224
(503) 624-0890
800-851-4118
FAX: (503) 684-6107
robinson@ronsservice.com

PENNSYLVANIA

A.I.S. COMMERCIAL PARTS & SERVICE

1816 WEST 26TH STREET
ERIE, PA 16508
(814) 456-3732
800-332-3732
FAX: (814) 452-4843
aiserie@aol.com

ELMER SCHULTZ SVC.

540 NORTH 3RD STREET
PHILADELPHIA, PA 19123
(215) 627-5400
FAX: (215) 627-5408
elmer2@erols.com

GCS SERVICE INC.

PHILADELPHIA, PA
(215) 925-6217
800-441-9115
FAX: (215) 925-6208

GCS SERVICE INC.

HARRISBURG, PA
(717) 564-3282
800-367-3225
FAX: (717) 564-9286

GCS SERVICE INC.

PITTSBURGH, PA
(412) 787-1970
800-738-1221
FAX: (412) 787-5005

K & D PARTS AND SERVICE CO.

1833-41 N CAMERON STREET
HARRISBURG, PA 17103
(717) 236-9039
800-932-0503
FAX: (717) 238-4367
kdparts-service@paonline.com

CLARK SERVICE & PARTS

306 AIRPORT DRIVE
BOX 10
SMOKETOWN, PA 17576
(717) 392-5590
(717) 392-5735

SECTION 7: JACKSON MAINTENANCE & REPAIR CENTERS

RHODE ISLAND TO WISCONSIN

RHODE ISLAND

GCS SERVICE INC.
EAST PROVIDENCE, RI
(401) 434-6803
800-462-6012
FAX: (401) 438-9400

SUPERIOR KITCHEN SERVICE INC.

669 ELMWOOD AVENUE
PROVIDENCE, RI 02907
(888) 590-1899
(401) 781-1996 FAX

SOUTH CAROLINA

AUTHORIZED APPLIANCE SERVICECENTER

1811 TAYLOR ST.
COLUMBIA, SC 29202
(803) 254-8414
FAX: (803) 254-5146

AUTHORIZED APPLIANCE SERVICECENTER

2249 AUGUSTA RD.
GREENVILLE, SC 29605
(864) 235-9616
FAX: (864) 235-9623

WHALEY FOODSERVICE REPAIRS

I 26&US1
P.O. BOX 4023
WEST COLUMBIA, SC 29170
(803) 791-4420
800-877-2662
FAX: (803) 794-4630
info@whaleyfoodservice.com

WHALEY FOODSERVICE REPAIRS

748 CONGAREE ROAD
GREENVILLE, SC 29607
(864) 234-7011
800-494-2539
FAX: (864) 234-6662
info@whaleyfoodservice.com

WHALEY FOODSERVICE REPAIRS

1406-C COMMERCE PL.
MYRTLE BEACH, SC 29577
(843) 626-1866
FAX: (843) 626-2632
info@whaleyfoodservice.com

WHALEY FOODSERVICE REPAIRS

4740-A FRANCHISE STREET
N. CHARLESTON, SC 29418
(843) 760-2110
FAX: (843) 760-2255
info@whaleyfoodservice.com

SOUTH DAKOTA

GCS SERVICE INC.

MINNEAPOLIS, MN
(612) 546-4221
800-345-4221
FAX: (612) 546-4286

GENERAL PARTS, INC.

10 SOUTH 18TH STREET
FARGO, ND 58103
(701) 235-4161
(800) 279-9987
(701) 235-0539 FAX

TENNESSEE

GCS SERVICE INC.

MEMPHIS, TN
(901) 366-4587
800-262-9155
FAX: (901) 366-4588

GCS SERVICE INC.

NASHVILLE, TN
(615) 244-8050
800-831-7174
FAX: (615) 244-8885

TEXAS

ARMSTRONG REPAIR CENTER

5110 GLENMOUNT DRIVE
HOUSTON, TX 77081
(713) 666-7100
800-392-5325
FAX: (713) 661-0520
gm@armstrongrepair.com

COMMERCIAL KITCHEN REPAIR CO.

1377 N BRAZOS
P.O BOX 831128
SAN ANTONIO, TX 78207
(210) 735-2811
800-292-2120
FAX: (210) 735-7421
brock@commercialkitchen.com

GCS SERVICE INC.

DALLAS, TX
(972) 484-2954
800-442-5026
FAX: (972) 484-2531

GCS SERVICE INC.

HOUSTON, TX
(713)785-9187
800-868-6957
FAX: (713) 785-3979

GCS/STOVE PARTS

2120 SOLANA STREET
FORT WORTH, TX 76117
(817) 831-0381
800-433-1804
FAX: (817) 834-7754
bud@stoveparts.com

UTAH

LA MONICA'S RESTAURANT EQMT. SVC.

6182 SOUTH STRATLER AVENUE
MURRAY, UT 84107
(801) 263-3221
800-527-2561
FAX: (801) 263-3229
lamonica81@aol.com

VERMONT

NORTHERN PARTS & SVC.

4874 S. CATHERINE STREET
PLATTSBURGH, NY 12901
(518) 563-3200
800-634-5005
FAX: (800) 782-5424
info@northernparts.com

GCS SERVICE INC.

CHELSEA, MA
(617)889-9393
800-225-1155
FAX: (617) 889-1222

VIRGINIA

DAUBERS, INC.

7645 DYNATECH COURT
SPINGFIELD, VA 22153
(703) 866-3600
800-554-7788
FAX: (703) 866-4071
daubers@aol.com

GCS SERVICE INC.

SILVER SPRING, MD
(301) 585-7550(DC)
(410) 792-0388(BALT)
800-638-7278
FAX: (301)495-4410

GCS SERVICE INC.

RICHMOND, VA
(804) 672-1700
800-899-5949
FAX: (804) 672-2888

GCS SERVICE INC.

VIRGINIA BEACH, VA
(757) 464-3500
800-476-4278
FAX: (757) 464-4106

WASHINGTON

GCS SERVICE INC.

SEATTLE, WA
(206) 763-0353
800-211-4274
FAX: (206) 763-5943

RESTAURANT APPLIANCE SERVICE

7219 ROOSEVELT WAY, NE
SEATTLE, WA 98115
(206) 524-8200
800-433-9390
FAX: (206) 525-2890
info@restappl.com

WEST VIRGINIA

STATEWIDE SERVICE, INC.

603 MAIN AVE.
NITRO, WV 25143
(304) 755-1811
(800) 441-9739
FAX: (304) 755-4001
sws3182@aol.com

WISCONSIN

APPLIANCE SERVICE CENTER, INC.

2439 ATWOOD AVE
MADISON, WI 53704
(608) 246-3160
800-236-7440
FAX: (608) 246-2721
ascmad@execpc.com

APPLIANCE SERVICE CENTER, INC.

6843 W. BELOIT RD.
WEST ALLIS, WI 53219
(414) 543-6460
800-236-6460
FAX: (414) 543-6480
ascmil@execpc.com

APPLIANCE SERVICE CENTER

786 MORRIS AVE
GREEN BAY, WI 54304
(920) 496-9993
800-236-0871
FAX: (920) 496-9927
ascfox@execpc.com

SECTION 7: JACKSON MAINTENANCE & REPAIR CENTERS

WISCONSIN TO WYOMING/INTERNATIONAL

GENERAL PARTS, INC.

W223 N735 SARATOGA DRIVE
WAUKESHA, WI 53186
(262) 650-6666
(800) 279-9946
(262) 650-6660 FAX

WYOMING

HAWKINS COMMERCIAL APPLIANCE SERVICE

3000 S. WYANDOT ST.
ENGLEWOOD, CO 80110
(303) 781-5548
(800) 624-2117
FAX: (303) 761-5561
johns@hawkinscommercial.com

METRO APPLIANCE SERVICE

1640 S BROADWAY
DENVER, CO 80210
(303) 778-1126
800-525-3532
FAX: (303) 778-0268
metroappls@aol.com

INTERNATIONAL

GLOBAL PARTS AND SUPPLY

7758 NW 72ND ST
MIAMI, FL 33166
(305) 885-6353

H.D. SHELDON AND CO

19 UNION SQUARE, WEST
NEW YORK, NY 10003
(212) 627-1759
(212) 924-6920

CANADA

THE GARLAND GROUP

1177 KAMATO ROAD
MISSISSAUGA, ONTARIO L4W
1X4
(905) 206-8380
SALES
(905) 624-1419
FAX: (905) 624-1851
SERVICE
800-427-6668
FAX: 800-361-7745

March 13, 2007

