

# AVENGER® SERIES

UNDERCOUNTER  
DISHMACHINES



*Warewashing Systems*

## INSTALLATION, OPERATION & SERVICE MANUAL

FOR JACKSON MODEL(S):

**AVENGER HT-E**  
**AVENGER LT-E**





# **MANUFACTURERS WARRANTY**

## **ONE YEAR LIMITED PARTS & LABOR WARRANTY**

**ALL NEW JACKSON DISHWASHERS ARE WARRANTED TO THE ORIGINAL PURCHASER TO BE FREE FROM DEFECTS IN MATERIAL OR WORKMANSHIP, UNDER NORMAL USE AND OPERATION FOR A PERIOD OF (1) ONE YEAR FROM DATE OF PURCHASE, BUT IN NO EVENT TO EXCEED (18) EIGHTEEN MONTHS FROM DATE OF SHIPMENT FROM THE FACTORY.**

Jackson WWS agrees under this warranty to repair or replace, at its discretion, any original part which fails under normal use due to faulty material or workmanship during the warranty period, providing the equipment has been unaltered, and has been properly installed, maintained and operated in accordance with applicable factory instruction manual furnished with the machine and failure is reported to the authorized service agency within the warranty period. This includes the use of factory specified genuine replacement parts, purchased directly from a Jackson authorized parts distributor or service agency. Use of generic replacement parts may create a hazard and void warranty certification.

The labor to repair or replace such failed part will be paid by Jackson WWS, within the continental United States, Hawaii and Canada, during the warranty period provided a Jackson WWS authorized service agency, or those having prior authorization from the factory, performs the service. Any repair work by persons other than Jackson WWS authorized service agency is the sole responsibility of the customer. Labor coverage is limited to regular hourly rates; overtime premiums and emergency service charges will not be paid by Jackson WWS.

Accessory components not installed by the factory carry a (1) one year parts warranty only. Accessory components such as table limit switches, pressure regulators, pre-rinse units, etc. that are shipped with the unit and installed at the site are included. Labor to repair or replace these components is not covered by Jackson WWS.

This warranty is void if failure is a direct result from shipping, handling, fire, water, accident, misuse, acts of God, attempted repair by authorized persons, improper installation, if serial number has been removed or altered, or if unit is used for purpose other than originally intended.

### **TRAVEL LIMITATIONS**

Jackson WWS limits warranty travel time to (2) two hours and mileage to (100) one hundred miles. Jackson WWS will not pay for travel time and mileage that exceeds this, or any fees such as those for air or boat travel without prior authorization.

### **WARRANTY REGISTRATION**

To register your product go to [www.jacksonwws.com](http://www.jacksonwws.com) or call 1-888-800-5672. Failure to register your product will void the warranty.

### **REPLACEMENT PARTS WARRANTY**

Jackson replacement parts are warranted for a period of 90 days from date of installation or 180 days from the date of shipment from the factory, whichever occurs first.

### **PRODUCT CHANGES AND UPDATES**

Jackson WWS reserves the right to make changes in design and specification of any equipment as engineering or necessity requires.

THIS IS THE ENTIRE AND ONLY WARRANTY OF JACKSON WWS. JACKSON'S LIABILITY ON ANY CLAIM OF ANY KIND, INCLUDING NEGLIGENCE, WITH RESPECT TO THE GOODS OR SERVICES COVERED HEREUNDER, SHALL IN NO CASE EXCEED THE PRICE OF THE GOODS OR SERVICES OR PART THEREOF WHICH GIVES RISE TO THE CLAIM.

THERE ARE NO WARRANTIES, EXPRESSED OR IMPLIED, INCLUDING FOR FITNESS OR MERCHANTABILITY, THAT ARE NOT SET FORTH HEREIN, OR THAT EXTEND BEYOND THE DURATION HEREOF. UNDER NO CIRCUMSTANCES WILL JACKSON WWS BE LIABLE FOR ANY LOSS OR DAMAGE, DIRECT OR CONSEQUENTIAL, OR FOR THE DAMAGES IN THE NATURE OF PENALTIES, ARISING OUT OF THE USE OR INABILITY TO USE ANY OF ITS PRODUCTS.

### **ITEMS NOT COVERED**

THIS WARRANTY DOES NOT COVER CLEANING OR DELIMING OF THE UNIT OR ANY COMPONENT SUCH AS, BUT NOT LIMITED TO, WASH ARMS, RINSE ARMS OR STRAINERS AT ANYTIME. NOR DOES IT COVER ADJUSTMENTS SUCH AS, BUT NOT LIMITED TO TIMER CAMS, THERMOSTATS OR DOORS, BEYOND 30 DAYS FROM THE DATE OF INSTALLATION. IN ADDITION, THE WARRANTY WILL ONLY COVER REPLACEMENT WEAR ITEMS SUCH AS CURTAINS, DRAIN BALLS, DOOR GUIDES OR GASKETS DURING THE FIRST 30 DAYS AFTER INSTALLATION. ALSO, NOT COVERED ARE CONDITIONS CAUSED BY THE USE OF INCORRECT (NON-COMMERICAL) GRADE DETERGENTS, INCORRECT WATER TEMPERATURE OR PRESSURE, OR HARD WATER CONDITIONS.

# REVISION HISTORY

Revision Letter	Revision Date	Made By	Applicable ECNs	Details
A	04/17/13	RLC	ECR 8259	Release to Production
B	02/20/14	MHH	QOF NDB 229	Update control, wash and strainer assemblies. Update schematic.
C	06/27/14	MHH	8301	Update Schematic
D	07/02/14	RC	QOF-NDB-266	Removed Ventilation Requirements
E	07/30/14	KAP	QOF 386	Update Schematic
F	10/14/14	KAP	ECR-8318	pg. 28. Added: 480V Heater Gasket P/N - 05330-004-13-19 480V Heater P/N - 04540-004-12-29 pg. 31-32 Added: 480V Control Box and Legend pg. 40 Added: 480V Units P/N - 05330-011-47-79 480V Units P/N - 05700-004-13-25 480V P/N - 04540-004-13-30 pg. 41 Added: 480V Units P/N - 06105-004-07-54
G	02/04/15	KAP	N/A	Updated water pressure info on pg's 4 & 5.
H	02/13/15	KAP	N/A	Updated PLC screens on pg's 14, 16, 18, 21, & 22.
J	03/11/15	KAP	N/A	Updated Drawings on pg's. 35, 36, 41, 43, 46 Changed item # 18 description on pg. 42 Added VAC breaker Repair kit P/N on pg. 43 Updated Drawings on pg's. 35, 36, 41, 43, 46 Changed item # 18 description on pg. 42 Added VAC breaker Repair kit P/N on pg. 43 Added wash arm assembly on pg. 40 Corrected P/N for items 5 & 6 on pg. 31 Added lower float switch on pg. 29 Updated description for item # 10 on pg. 39 Updated description for item # 1 & 2 on pg. 35 Updated 208/230 schematic on pg. 51
K	04-01-15	KAP	N/A	Updated P/N for item #6 on pg 31.
L	04-15-15	KAP	ECR - 8328	Updated transducer & Harness P/N pg's 42 & 44 Updated 208/230 Volt & 480 Volt Electrical Diagram pg's 51 & 52.
M	05-18-15	KAP	N/A	Updated P/N for item 6 on pg 36 Updated P/N for item 19 on page 36 Included door spring in drawing on pg 36 Updated float switches pg's. 17 & 30 Updated item #4 P/N on pg. 37 Updated Door Spring Assembly pg 36 & 37
N	06-10-15	KAP	N/A	Added 2 wire door switch cable pg. 27



**AVENGER HT-E**

High temperature, hot water sanitizing, with a booster tank  
detergent & rinse aid chemical feeder pumps

**AVENGER LT-E**

Low temperature, chemical sanitizing, with detergent,  
rinse aid & sanitizer chemical feeder pumps.

Model: \_\_\_\_\_

Serial No.: \_\_\_\_\_

Installation Date: \_\_\_\_\_

Service Rep. Name: \_\_\_\_\_

Phone Number: \_\_\_\_\_

Jackson WWS, Inc. provides technical support for all of the dishmachines detailed in this manual. We strongly recommend that you refer to this manual before making a call to our technical support staff. Please have this manual with you when you call so that our staff can refer you, if necessary, to the proper page. Technical support is not available on holidays. Contact technical support toll free at 1-888-800-5672.

Technical support is available for service personnel only.

# TABLE OF CONTENTS

<b>SPECIFICATIONS .....</b>	<b>1</b>
Machine Dimensions .....	1
Operating Parameters .....	2
Electrical Requirements .....	3
<b>INSTRUCTIONS .....</b>	<b>4</b>
Installation .....	4
Chemical Feeder Pump Programming .....	8
Detergent Control .....	9
Operating .....	10
Delime .....	11
<b>MAINTENANCE .....</b>	<b>12</b>
Preventative Maintenance .....	12
Troubleshooting .....	13
PLC Troubleshooting .....	16
<b>PARTS .....</b>	<b>26</b>
Machine Assemblies .....	26
Terminal Block Box Assembly .....	28
Control Panel .....	29
Control Kick Panel .....	31
208/230V Control Box .....	32
480V Control Box .....	33
115V Control Box .....	34
Chemical Feeder Pump Assembly .....	35
Door Assembly .....	36
Wash Motor Assembly .....	38
Wash Arm Assembly .....	40
Rinse Manifold Assembly .....	41
Plumbing Assemblies .....	42
Rinse Tank Assembly .....	46
Wash Pump Assembly .....	48
<b>SCHEMATICS .....</b>	<b>50</b>
115 Volt Electrical Diagram .....	50
208/230 Volt Electrical Diagram .....	51
480 Volt Electrical Diagram .....	52

# MACHINE DIMENSIONS

# SPECIFICATIONS

## LEGEND

A: Water Inlet— $\frac{1}{2}$ " female pipe thread, 2  $\frac{1}{2}$ " AFF (Connect to a true  $\frac{1}{2}$ " ID water line)

B: Electrical Connection

C: Drain Connection—6' coiled drain hose. Shipped inside machine. Must be installed no more than 24" AFF.

All dimensions from floor can be increased 1" with adjustable feet supplied.

**NOTE: All dimensions are for reference only and are subject to change without notice.**

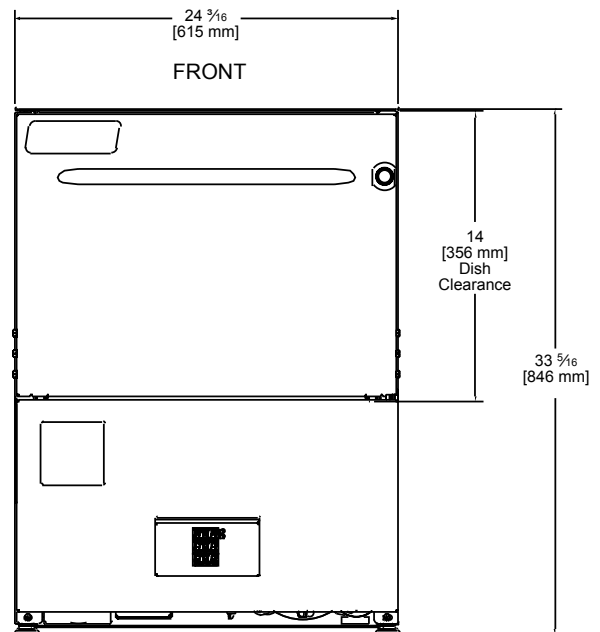
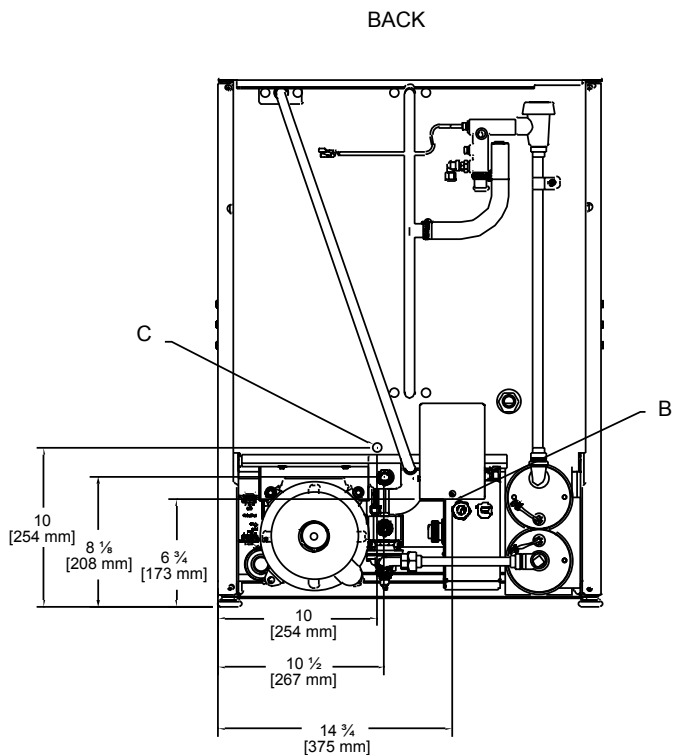
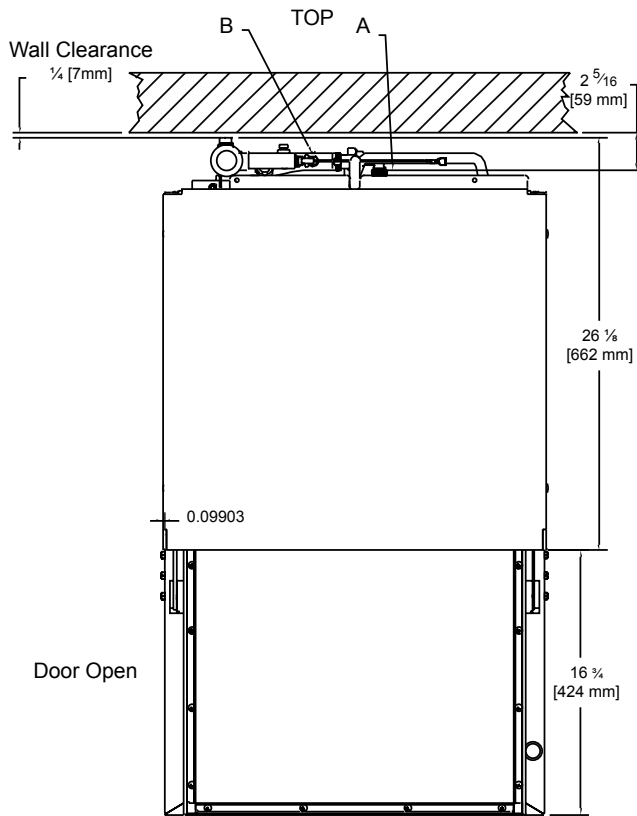

**Model Designation:                      AVENGER HT-E    AVENGER LT-E**

**Operating Capacity:**

Racks per Hour	26	30
Dishes per Hour	468	480
Glasses per Hour	936	960

**Tank Capacity (Gallons):**

Wash Tank	3	3
Rinse Tank	2.12	N/A

**Electrical Loads (as applicable):**

Wash Motor HP	0.75	0.75
Wash Heater KW	4	1.5
Rinse Heater KW	4	N/A

**NOTE: Always refer to the machine data plate for specific electrical and water requirements. The material provided on this page is for reference only and is subject to change without notice.**

**HOT WATER SANITIZING**

**CHEMICAL SANITIZING**

**Water Temperatures (Fahrenheit):**

Minimum Wash Temperature	155	120
Minimum Rinse Temperature	180	120
Minimum Incoming Water Temperature	110	120 (140 Recommended)

**Other Water Requirements:**

Water Flow Pressure (PSIG)	10	20
Flow Rate Minimum (GPM)	5.16	5.16
Water Line Size (NPT)	1/2"	1.2"
Drain Line Size (NPT)	1-3/8"	1-3/8"
Minimum Chlorine Required (PPM)	N/A	50PPM



NOTE 1: MCA (Minimum Circuit Ampacity) = 125% x Largest Motor +FLA of all other motors + all other loads.

NOTE 2: MOP (Maximum Overcurrent Protective Device) = 225% x Largest Motor + FLA of all other motors + all other loads.

All electrical ratings provided in this manual are for reference only. Always refer to the machine data plate to get exact electrical information for this machine. All electrical work performed on machines should be done in accordance with applicable local, state, territorial and national codes. Work should only be performed by qualified electricians and authorized service agents. A list of authorized service agencies is located in the back of this manual.

Note that all electrical wiring used in the AVENGER series of machines must be rated, at a minimum, for 100°C (212°F). Furthermore, use copper conductors only.

Where applicable, heating element amperage draws have been adjusted for the assumed input voltage. Jackson assumes incoming voltages will be either 208 or 230 volts. Some heating elements used in the machines are rated for other voltages, such as 240 volts. Always verify the amperage draw of the machine in operation when sizing circuit protection.

If the dishmachine is equipped with the optional rinse heater, note the rinse heater may have its own electrical connection and therefore require a separate service. Amperage loads for motors and heaters are indicated on the machine data plate.

The electrical configurations of the AVENGER series of machines are as follows:

**Available Electrical Characteristics:**

- 115 volt, 60 Hz, single phase ( AVENGER LT-E only)
- 230 volt, 60 Hz, single phase
- 208 volt, 60 Hz, single phase
- 460 volt, 60 Hz, three phase

**Available Wash Tank Heaters:**

- 1.5KW (standard for AVENGER LT-E only)
- 4KW (standard for AVENGER HT-E)

**Available Rinse Tank Heaters:**

- 2KW for top tank (standard for AVENGER HT-E)
- 2KW for bottom tank (standard for AVENGER HT-E)

**AVENGER HT-E  
Electrical Characteristics**

<b>VOLTS</b>	115	208	230	480
<b>PHASE</b>	1	1	1	3
<b>FREQ</b>	60	60	60	60
<b>WASH MOTOR AMPS</b>	13.2A	6.6 A	6.6 A	1.3A
<b>DRAIN PUMP</b>	1.0A	0.6 A	0.6 A	1.0A
<b>WASH HEATER AMPS</b>	13.0A	15.9 A	17.4 A	5.0A
<b>RINSE HEATER AMPS</b>	N/A	15.9 A	17.4 A	5.0A
<b>FLA</b>	13.2A	38.4 A	41.4 A	11.3A
<b>MCA</b>	16.5A	41.35 A	44.35 A	11.63A
<b>MOP</b>	30A	50 A	60 A	17.55A

**VISUAL INSPECTION**

***DO NOT THROW AWAY  
CONTAINER IF DAMAGE  
IS EVIDENT***

Before installing unit, check container and machine for damage. A damaged container may be an indication of damage to the machine. If there is any type of damage to both container and unit, do not throw away the container. The dishmachine has been inspected at the factory prior to shipping and is expected to arrive in new, undamaged condition. However, rough handling by carriers or others may result in damage to the unit while it is in transit. If such a situation occurs, do not return the unit to the manufacturer. Instead, contact the carrier and ask them to send a representative to the site to inspect the damage, and request that an inspection report be completed.

Contact the carrier within 48 hours of receiving the machine (to report possible freight damage) and the dealer from whom the unit was purchased.

---

**UNPACKING THE  
MACHINE**

The machine should be unboxed and removed from the pallet prior to installing. Open the front door and remove all of the materials from the inside. Once unpacked, verify there are no missing parts. If a part is missing, contact manufacturer immediately.

---

**LEVEL THE  
DISHMACHINE**

The dishmachine is designed to operate while level. This is important to prevent any damage to the machine during operation and to ensure the best results possible. The unit comes equipped with adjustable bullet feet which can be turned using a pair of pliers. Verify the unit is level from front to back and side to side before making any electrical or plumbing connections.

---

**PLUMBING THE  
DISHMACHINE**

***A water hardness test  
must be performed.***

All plumbing connections must be made to adhere to local, state, territorial and national codes. The installing plumber is responsible for ensuring the incoming water lines are flushed of debris prior to connecting to the machine. Note that chips and materials from cutting processes can become lodged in the solenoid valves and prevent them from opening or closing. Any valves that are found to be fouled or defective because of foreign matter left in the water line, and any subsequent water damage, are not the responsibility of the manufacturer.

A water hardness test must be performed to determine if the HTS-11 (scale prevention & corrosion control) needs to be installed. A hardness test kit can be found on the warning tag that is attached to the incoming plumbing connection on the back of the machine. If water hardness is higher than 5 GPG, the HTS-11 will need to be installed. Please contact manufacturer to purchase the HTS-11.

### **WATER SUPPLY CONNECTIONS: WATER HARDNESS GREATER THAN 5 GPG**

If water hardness tests at greater than 5 GPG, install the HTS-11 into the water line (1/2" ID pipe size minimum) before the dishwasher's incoming water connection point using copper pipe. Observe proper inlet/outlet water directions. Flow directions are molded into the top of the head. It is recommended that a water shut-off valve be installed prior to installation of the HTS-11 to allow access for servicing. Plumb from the HTS-11 outlet to the incoming water connection point using copper pipe (or order the 1/2" ID flexible hose kit offered by manufacturer). The water supply must be capable of a minimum of 10 PSI "flow" pressure at the recommended temperature indicated on the data plate. See "Shock Absorber" section.

### **WATER SUPPLY CONNECTION: WATER HARDNESS OF 5 GPG OR LESS**

If water hardness tests at 5 GPG or less, install the water supply line (1/2" ID pipe size minimum) to the dishwasher's incoming water connection point using copper pipe (or order the 1/2" ID flexible hose kit offered by manufacturer). It is recommended that a water shut-off valve be installed in the water line between the main supply and the machine to allow access for service. The water supply line must be capable of a minimum of 10 PSI "flow" pressure at the recommended temperature indicated on the data plate.

### **PRESSURE REGULATOR**

*Take care not to confuse static pressure with flow pressure.*

The manufacturer has a optional water pressure regulator to accommodate areas where water pressure fluctuates or is higher than the recommended pressure. Take care not to confuse static pressure with flow pressure: Static pressure is line pressure in a "no flow" condition (all valves and services are closed). If water hardness tests at 5 GPG or less, install the water supply line (1/2" ID pipe size minimum) to the dishwasher's incoming water connection point using copper pipe (or order the 1/2" ID flexible hose kit offered by manufacturer). It is recommended that a water shut-off valve be installed in the water line between the main supply and the machine to allow access for service. The water supply line must be capable of a minimum of 10 PSI "flow" pressure at the recommended temperature indicated on the data plate. ); flow pressure is the pressure in the fill line when the valve is opened during the cycle.

### **SHOCK ABSORBER**

It is suggested that a shock absorber (not supplied) be installed on the incoming water line. This prevents water hammer (hydraulic shock)—induced by the solenoid valve as it operates—from causing damage to the equipment.

### **CONNECTING THE DRAIN LINE**

The dishwasher has a pumped (pressure) drain capable of pumping waste water to a height of 24" above the floor to the kitchen's drain system. Each dishwasher is supplied with a ten foot long hose. This ships installed on the unit. When installed, it will extend from the rear side of the machine. There must be an air gap between the machine drain line and the floor sink or drain. If a grease trap is required by code, it should have a flow capacity of 12 GPM (Gallons Per Minute).

### **PLUMBING CHECK**

Slowly turn on the water supply to the machine after installing the incoming fill line and the drain line. Check for any leaks and repair as required. All leaks must be repaired prior to placing the machine into operation.

**ELECTRICAL POWER CONNECTIONS**

Electrical and grounding conductors must comply with the applicable portions of the National Electric Code ANSI/NFPA 70 (latest edition) and/or other electrical codes.

**DISCONNECT ELECTRICAL POWER SUPPLIES & TAG OUT IN ACCORDANCE WITH APPROPRIATE PROCEDURES & CODES AT THE DISCONNECT SWITCH TO INDICATE THE CIRCUIT IS BEING SERVICED.**

The data plate is located at the left front side of the dishmachine. Refer to the data plate for machine operating requirements, machine voltage, total amperage & serial number.

Remove the back panel to install the incoming power lines. This will require removing the screw at the bottom of the back panel with a Phillips head screw driver. Remove the back panel and set aside. Install 3/4" conduit into the pre-punched holes in the back of the control box. Route power wires and connect to power block and grounding lug. Install the service wires (L1 and L2) to the appropriate terminals as they are marked on the terminal block. Install the grounding wire into the lug provided. It is recommended that "DE-OX" or another similar anti-oxidation agent be used on all power connections.

**VOLTAGE CHECK**

Ensure that the power button is in the off position and apply power to dishmachine. Check the incoming power at the terminal block and ensure it corresponds with the voltage listed on the data plate. If not, contact a qualified service agency (listed at the end of this manual) to examine the problem. Do not run dishmachine if voltage is too high or too low. Shut off the service breaker and advise all proper personnel of the location of the breaker and any problems. Replace the control box cover and tighten down the screws.

**SURROUNDING AREA**

This is a commercial dishmachine and reaches temperatures that can exceed those generated by a residential machine. Therefore, any surrounding countertops, cabinets, flooring material & subfloor material must be designed and/or selected with these higher temperatures in mind. Note: Any damage to surrounding area that is caused by heat and/or moisture to materials that are not recommended for higher temperatures will not be covered under warranty or by Jackson WWS, INC.

**TEMPERATURE SETPOINTS**

The temperature setpoints on this Avenger unit have been set at the factory. They should only be adjusted by an authorized service agent.

## CHEMICAL FEEDER EQUIPMENT

### **WARNING!**

**CHLORINE-BASED SANITIZERS CAN BE DETRIMENTAL TO THIS MACHINE IF THE CHEMICAL SOLUTION IS TOO STRONG. SEE A CHEMICAL PROFESSIONAL TO ENSURE THE DISPENSER IS SET UP CORRECTLY.**

This equipment is not recommended for use with deionized water or other aggressive fluids. Use of deionized water or other aggressive fluids will result in corrosion and failure of materials and components and will void the manufacturer's warranty.

The bottom of the chemical container cannot be located any higher than 8" from the floor. If the unit is equipped with the 6" or 18" table stand, the highest position will respectively be 14" or 26" from the floor.

## TO PREPARE CHEMICAL FEEDER PUMPS FOR OPERATION

The AVENGER HT-E dishmachine is supplied with detergent and rinse aid chemical feeder pumps.

The AVENGER LT-E dishmachine is supplied with detergent, rinse aid and sanitizer chemical feeder pumps.

Locate the open ends of the chemical tubes with the tube stiffeners and place each one in the appropriate container.

- A. Red Tubing = Detergent
- B. Blue Tubing = Rinse Aid
- C. White Tubing = Sanitizer

## PRIMING CHEMICAL FEEDER PUMPS

Chemical feeder pumps need priming when the machine is first installed or if the chemical lines have been removed and air is allowed to enter. CAUTION! Water must be in the sump and wash tank prior to the dispensing of chemicals. Sanitizer in concentration is caustic and may cause damage without dilution.

***WARNING: Some of the chemicals used in dishwashing may cause chemical burns if they come in contact with skin. Wear protective gear when handling these chemicals. If any skin comes in contact with these chemicals, immediately follow the instructions provided with the chemicals for treatment.***

1. Verify that the proper chemical tube stiffener inlet is in the proper container.
2. Use the prime buttons located on the control panel at the bottom of the unit to prime each pump. The buttons are clearly marked as to which chemical feeder pump they are assigned to.
3. To prime the pumps, press the button until the chemical can be observed entering the pump.
4. Detergent is dispensed as required during the wash cycle by the timer. The amount of detergent may need to be increased or decreased depending upon water quality and type of detergent.
5. Rinse additive is dispensed as required into the final rinse. The amount of rinse additive may need to be adjusted depending upon water hardness & results.
6. Please refer to "Programming Instructions for Chemical Feeder Pumps" for instruction on adjusting the chemical feeder pumps on the Programmable Logic Controller (PLC).

## PROGRAMMING INSTRUCTIONS FOR CHEMICAL FEEDER PUMPS (INSTALLATION TECHNICIAN ONLY)

The chemical feeder pump timers are located on screens 3, 4 & 5. To access the programming mode follow the process detailed below.

1. Press "A" to cycle through screens until reaching the "Fill Cycle Timers" screen (#3).
2. Press "+" or "-" to highlight the timer in need of adjustment and press "OK" to enter edit mode for that timer.
3. Press "+" or "-" to make needed adjustments and press "OK" to confirm.
4. Press "A" and continue to the "Wash Cycle Timers" screen (#4). Follow steps 2 & 3 to confirm any adjustments.
5. Press "A" and continue to the "Wash Cycle Timers" screen (#5). Follow steps 2 & 3 to confirm any adjustments.
6. Press "A" & "B" simultaneously to return to the home screen (#1). Run the machine through several cycles to verify changes.

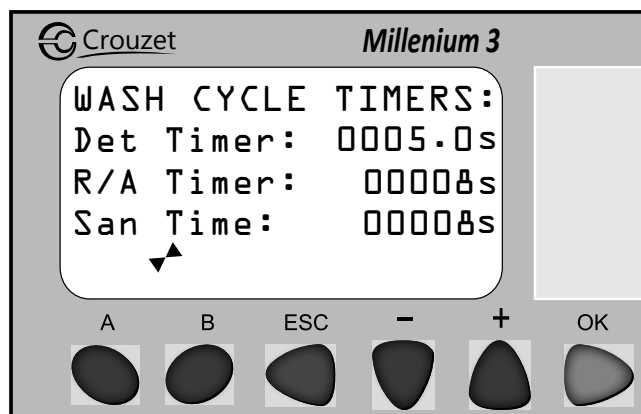
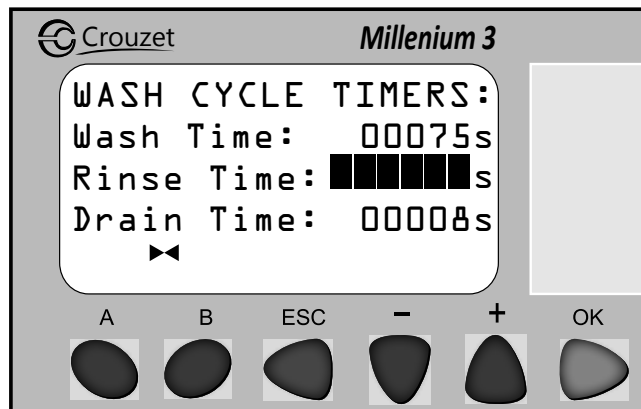
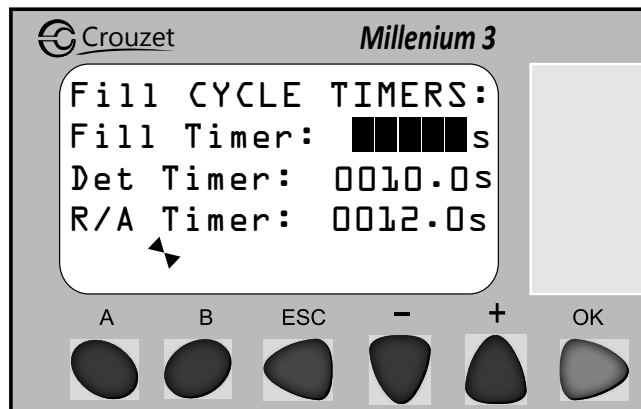

**DETERGENT CONTROL**

Detergent usage and water hardness are two factors that contribute greatly to how efficiently this dishmachine will operate. Using detergent in the proper amount can become a source of substantial savings. A qualified water treatment specialist can relate what is needed for maximum efficiency from the detergent.

1. Hard water greatly affects the performance of the dishmachine, causing the amount of detergent required for washing to increase. If the machine is installed in an area with hard water, the manufacturer recommends the installation of water treatment equipment.
2. Deposited solids from hard water can cause spotting that will not be removed with a drying agent. Treated water will reduce this occurrence.
3. Treated water may not be suitable for use in other areas of operation and it may be necessary to install a water treatment unit for the water going to the dishmachine only. Discuss this option with a qualified water treatment specialist.
4. Dishmachine operators should be properly trained in how much detergent is to be used per cycle. Meet with a water treatment specialist and detergent vendor to discuss a complete training program for operators.
5. Certain dishmachine models require that chemicals be provided for proper operation and sanitization. Some models may require the installation of third-party chemical feeders to introduce those chemicals to the machine. The manufacturer does not recommend or endorse any brand name of chemicals or chemical dispensing equipment. Contact a chemical distributor for questions.
6. Some dishmachines come equipped with integral solid detergent dispensers. These dispensers are designed to accommodate detergents in a certain-sized container. If applicable, relate this to a chemical distributor upon first contacting them.
7. Water temperature is an important factor in ensuring that the dishmachine functions properly, and the machine's data plate details what the minimum temperatures must be for the incoming water supply, the wash tank and the rinse tank. If minimum requirements are not met, there is a possibility that dishes will not be clean or sanitized.
8. Instruct dishmachine operators to observe the required temperatures and to report when they fall below the minimum allowed. A loss of temperature can indicate a larger problem—such as a failed heater—or could indicate that the hot water heater for the operation is not up to capacity and a larger one may need to be installed.

**PREPARATION** Before proceeding with the start-up of the unit, verify the following:

1. Strainers are in place and clean.
2. Wash and rinse arms are screwed securely into place and end caps are tight.
3. Wash and rinse arms rotate freely.
4. Chemical levels for machine chemical feed pumps are correct.

---

**POWER UP** To energize the unit, turn on the power at the service breaker. The voltage should have been previously verified as being correct. If not, the voltage must be verified before energizing the unit.

---

**FILLING THE WASH TUB** For the initial fill, verify the standpipe is installed correctly (seated vertically in the center of the wash sump), close the door and press the power button. The unit will automatically begin the fill cycle and fill to the proper level before allowing a wash cycle to start.

The water level is controlled by the standpipe. Verify that there are no leaks on the unit before proceeding any further. The wash sump must be completely filled before operating the wash pump to prevent damage to the component. Once the wash tub is filled, the unit is ready for operation.

The machine runs a complete cycle to drain and fill. If the machine fails to drain, the water will build up inside the tub. After the initial fill, the rinse water for the current cycle will mix with the wash water for the next cycle.

---

**WARE PREPARATION** Proper preparation of ware is essential for the smooth and efficient operation of the dishmachine, resulting in fewer rewashes and using less detergent. Any ware loaded inside the machine should have all solid food waste and scraps removed. It is recommended that the wares are sprayed down before placing in the dishmachine.

Place cups and glasses upside down in racks so they do not hold water during the cycle. Presoak flatware in warm water to assist in removal of stuck-on material. Load plates and saucers in the same direction.

---

**WARM-UP CYCLES** For a typical daily start-up, it is recommended to run the machine through 3 cycles to ensure that all cold water is out of the system and to verify that the unit is operating correctly. To cycle the machine, ensure that the power is on and that the tub has filled to the correct level. Push the start button: The unit will start, run through the cycle, and shut off automatically. Repeat this two more times. The unit should now be ready to proceed with the washing of ware.



**WASHING A RACK OF WARE** To wash a rack, open the door completely and slide the rack into the unit. Close the door, press the start button and the unit will start. After the machine has drained and the cycle light turns off, the cycle is complete.

**OPERATIONAL INSPECTION** As the workday progresses, operators should regularly inspect the pan strainer to ensure it has not become clogged. If the strainer becomes clogged, it will reduce the washing capability of the machine. Instruct operators to clean out the pan strainer at regular intervals or as required by work load.

**SHUTDOWN & CLEANING** At the end of the workday, open the door and remove the standpipe. Close the door and push the power button. This will drain the tub completely and prevent the machine from cycling. When the tub is empty, remove and clean the pan strainers and set aside. Unscrew the wash and rinse arms from their manifolds, remove the end caps and flush the arms with water. Use a brush to clean the inside of the arms. If the nozzles appear to be clogged, use a toothpick to remove the obstruction. Wipe the inside of the unit out, removing all soil and scraps. Reassemble the wash and rinse arms and place them and the strainers in the unit. The arms should be screwed on hand-tight; do not use tools to tighten them down.

**DELIMING OPERATIONS** In order to maintain the dishmachine at its optimum performance level, it is required to remove lime and corrosion deposits on a frequent basis. A deliming solution will be available from a detergent supplier. Read and follow all instructions on the label of the deliming solution.

To proceed with the deliming operation, fill the dishmachine and add the correct amount of deliming solution as recommended by the solution manufacturer. The water capacity of the tank can be verified on the specification sheet(s) of this manual.

Perform the following operations to delime the dishmachine:

1. Verify standpipe is in place, turn the unit on and allow to complete a fill cycle.
2. Verify water level. If low, switch the unit off then immediately back on (this will start a second fill cycle).
3. Open the door and verify water level is above standpipe. Add deliming solution per the solution manufacturer's recommendation.
4. Close the door and push the delime button on the front of the control panel.
5. Run the machine for the recommended period of time.
6. Press the delime button again and the pump will stop.
7. Open the door and remove the standpipe.
8. Press the power button to drain the machine and turn the unit off.
9. Wait five minutes, then inspect the inside of the machine. If the machine is not delimed, run another time cycle as per the deliming solution's instructions.
10. When clean, drain and refill the machine (steps 1 and 2).
11. Run delime mode for 10 minutes to remove residual deliming solution.
12. Drain and refill the machine.

**NOTE: If this machine is equipped with an HTS-11, scale prevention and corrosion control device, and lime is becoming a frequent problem, the cartridge needs to be replaced. To order a replacement cartridge, call the manufacturer to have one shipped.**

**PREVENTATIVE  
MAINTENANCE**

The manufacturer of this dishmachine highly recommends that any maintenance and repairs not specifically discussed in this manual should be performed by qualified service personnel only. Performing maintenance on the dishmachine may void a warranty.

By following the operating and cleaning instructions in this manual, users should get the most efficient results from the dishmachine. As a reminder, here are some steps to ensure that the dishmachine is used properly:

***FIND QUALIFIED  
SERVICE AGENCIES  
IN THE BACK  
OF THIS MANUAL.***

1. Ensure that the water temperatures match those listed on the machine data plate (on the front left of machine).
2. Remove as much soil as possible from dishes before loading into racks.
3. Ensure that all strainers are in place, laying flat in tub and free of soil and debris before operating the machine. To clean strainers, wipe them out with a rag and rinse under a faucet. For stubborn debris, a toothpick can be used to dislodge any obstructions from the perforations. Do not beat strainers on waste cans; once bent they will not work properly.
4. If hard water is present, install an HTS-11 into the water line connecting to the dishmachine (see section "Plumbing the Dishmachine").
5. Ensure that all wash and/or rinse arms are secure in the machine before operating.
6. Ensure that drains are closed/sealed before operating.
7. Do not overfill racks.
8. Ensure that glasses are placed upside down in the rack.
9. Ensure that all chemicals being injected into machine have been verified as being at the correct concentrations.
9. Clean out the machine at the end of every workday as per the instructions in the manual (see section on "Shutdown & Cleaning").
10. Always contact a qualified service agency whenever a serious problem arises.
11. Follow all safety procedures, whether listed in this manual or put forth by local, state or national codes/regulations.

PROBLEM	POSSIBLE CAUSE	REMEDY
Water overflow from bottom of door.	<ol style="list-style-type: none"> <li>1. Clogged drain.</li> <li>2. Machine not level.</li> <li>3. Excessive inlet pressure.</li> <li>4. Detergent foaming.</li> <li>5. Wash or rinse arm end plug missing.</li> <li>6. Top float failure.</li> </ol>	<ol style="list-style-type: none"> <li>1. Remove obstruction.</li> <li>2. Level machine or increase height to the front.</li> <li>3. Install pressure reducing valve or adjust if one is present. Ensure flow meets data plate specification.</li> <li>4. Reduce detergent quantity.</li> <li>5. Replace.</li> <li>6. Verify inputs on I/O (diagnostics) screen.</li> </ol>
Wash motor doesn't operate on delime wash.	<ol style="list-style-type: none"> <li>1. Loose or broken wires.</li> <li>2. Defective manual wash switch.</li> <li>3. Defective motor starting relay.</li> <li>4. Machine in FAULT mode and locked out.</li> </ol>	<ol style="list-style-type: none"> <li>1. Reconnect or replace wires in motor.</li> <li>2. Verify delime switch triggers input on PLC. If not, check wiring/replace membrane.</li> <li>3. Replace.</li> <li>4. Review fault screen for active faults.</li> </ol>
Motor operates on delime wash but not on automatic.	<ol style="list-style-type: none"> <li>1. Defective start switch</li> <li>2. Defective circuit in manual wash switch.</li> <li>3. Loose or broken wires.</li> </ol>	<ol style="list-style-type: none"> <li>1a. Check fault screens to verify no faults would prevent the machine from running a cycle</li> <li>1b. Verify start button triggers input on PLC. If not, check wiring/replace membrane.</li> <li>2. Replace switch.</li> <li>3. Tighten and/or replace.</li> </ol>
Little or no water coming through the rinse assemblies.	<ol style="list-style-type: none"> <li>1. Limed up rinse heads or piping.</li> <li>2. Low water pressure.</li> </ol>	<ol style="list-style-type: none"> <li>1. Delime rinse heads.</li> <li>2. Increase pipe size to machine. Adjust pressure regulator.</li> </ol>
Rinse water runs continuously with breaker turned off.	<ol style="list-style-type: none"> <li>1. Defective plunger in solenoid valve.</li> <li>2. Defective diaphragm in solenoid valve.</li> </ol>	<ol style="list-style-type: none"> <li>1. Replace.</li> <li>2. Replace diaphragm.</li> </ol>

<b>PROBLEM</b>	<b>POSSIBLE CAUSE</b>	<b>REMEDY</b>
Wash temperature not at required reading on home screen.	<ol style="list-style-type: none"> <li>1. Water level low.</li> <li>2. RTD set point too slow.</li> <li>3. Defective RTD.</li> <li>4. Wash heater defective.</li> <li>5. Defective heater contactor R1.</li> </ol>	<ol style="list-style-type: none"> <li>1. Check water level. If low, run new fill cycle.</li> <li>2. Check fault screen.</li> <li>3. Adjust wash temperature set point. Replace</li> <li>4. Replace heater element.</li> <li>5. Replace.</li> </ol>
Rinse water not at required temperature range.	<ol style="list-style-type: none"> <li>1. RTD is defective.</li> <li>2. Incoming rinse water does not meet minimum criteria indicated machine data plate.</li> <li>3. Rinse heaters damaged.</li> <li>4. Setpoint screens set low.</li> </ol>	<ol style="list-style-type: none"> <li>1. Replace if necessary.</li> <li>2. Adjust as required.</li> <li>3. Check amperages. Replace if necessary.</li> <li>4. Adjust rinse tank setpoint.</li> </ol>
Machine doesn't drain when power button is pressed.	<ol style="list-style-type: none"> <li>1. Drain clogged.</li> <li>2. Standpipe not removed prior to drain.</li> <li>3. Defective drain valve.</li> </ol>	<ol style="list-style-type: none"> <li>1. Remove obstruction.</li> <li>2. Remove standpipe and run drain cycle again.</li> <li>3. Replace.</li> </ol>
No indication of pressure.	<ol style="list-style-type: none"> <li>1. Water turned off.</li> <li>2. Transducer disconnected.</li> <li>3. Pressure transducer defective.</li> </ol>	<ol style="list-style-type: none"> <li>1. Turn water on.</li> <li>2. Verify wiring.</li> <li>3. Replace pressure transducer.</li> </ol>

## Avenger HT-E Decal

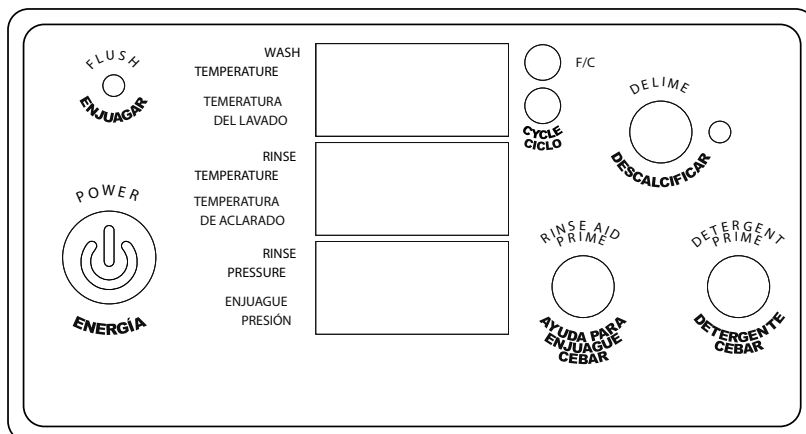

## Avenger LT-E Decal

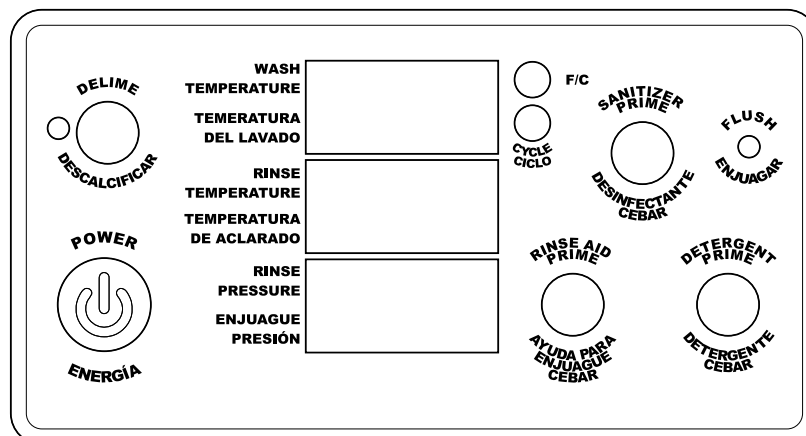

**FLUSH CYCLE** The "Flush" light will activate after the unit has completed a predetermined number of cycles. When this light activates it is recommended that the user complete a flush cycle as detailed in the steps below.

1. Open the machine door.
2. Remove the standpipe and set aside.
3. Close the door.
4. Press the power button.
  - When the power button is pressed the machine will start draining.
5. Once the drain cycle is complete, open the door and verify that the wash tank is empty.
  - If the wash tank is not empty, close the door and press the power button twice to start a second drain cycle.
6. When the machine is fully drained, reinstall the standpipe, close the door and press the power button.
  - Once the fill cycle is complete, the machine will be ready for regular use.

**FAULT INDICATION** If the machine sees a fault\*, the delime and "Flush" light will start to flash. Faults will generally clear through completion of a drain or wash cycle, but some faults indicate a serious issue in the dishwasher and may require additional support.

\*See PLC Troubleshooting section for more information on faults.

**SCREEN 1: HOME** The Avenger HT-E comes equipped with a PLC programmed to make troubleshooting and diagnostics more user-friendly. The following pages detail each screen associated with the Avenger HT-E PLC display.

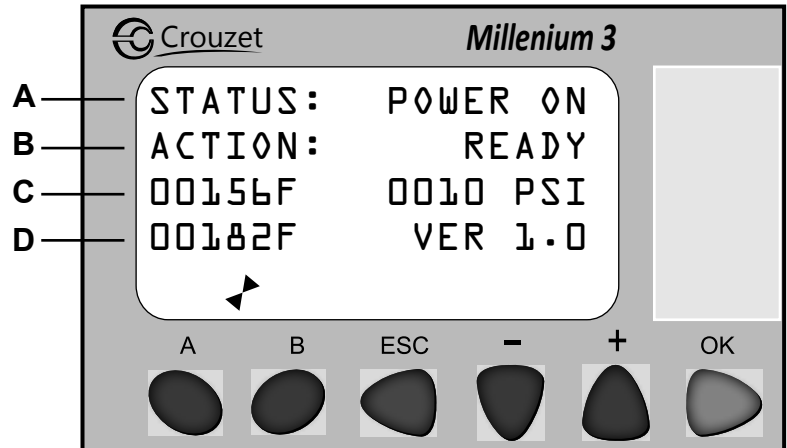

The home screen will be displayed when the machine is powered on and is intended to show the technician the status of the machine, any faults that may be present, and the wash and rinse temperatures.

1. Line A shows the status of the machine: Power On, Power Off or Delime.
2. Line B shows the action of the machine and will show one of the following options:
  - Fill: The machine is in the initial fill cycle.
  - Ready: The machine has completed the initial fill cycle and is ready to wash.
  - Wash: The machine is in the wash cycle.
  - Rinse: The machine is in the rinse cycle.
  - Drain: The machine has been turned off and is draining.
3. Line C will display the wash tank temperature and rinse line pressure.
  - If a fault is present, "!!FAULT!!" will replace the rinse line pressure.
  - If "!!FAULT!!" is displayed the operator should continue to screen #2 to identify the issue.
4. Line D will display current software version loaded onto the PLC.
5. Pressing "A" and "B" simultaneously will return user to screen #1.
6. Pressing "A" will proceed to the next screen.
7. Pressing "B" will return to the previous screen.

**SCREEN 2: FAULTS** The "Faults" screen will be displayed when the operator has pressed "A" or "B" to cycle through screens and is intended to show the technician any faults that have occurred.

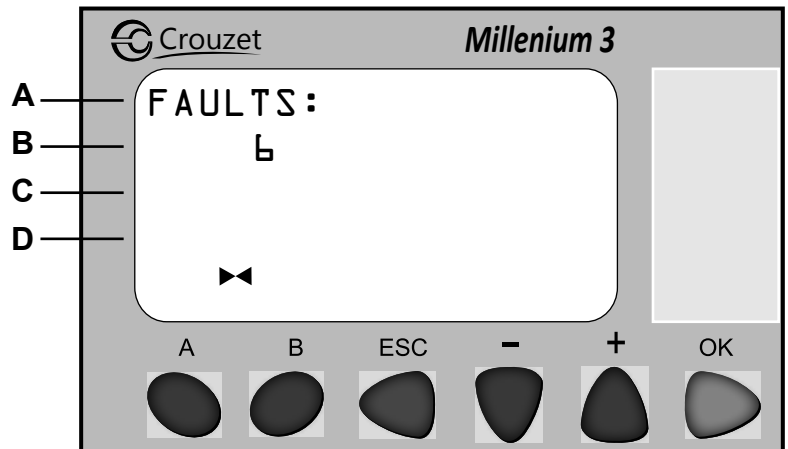

Line C will show any fault observed from previous cycles. The faults will be identified as 1-6 and are detailed below (multiple faults may be active at the same time):

Fault 1: Indicates the horizontal float switch did not close during the initial fill.

- Open the door and check the water level. If low, turn machine off then back on to start an additional fill cycle.

Fault 2\*: Indicates the vertical float switch has activated and the machine is overfilled.

- To clear this fault verify the water level and remove the standpipe.
- Attempt to drain the machine by cycling power on then off.
- If the machine is not overfilled, manually trigger the float switch and verify status of input on PLC.

Fault 3: Indicates the horizontal float switch opened for more than 5 seconds.

- Allow cycle to complete to determine if fault 3 clears.
- If not, open the door and verify the standpipe is fully seated, strainers are in place, and water level is low.

Fault 4: Indicates Sanisure was active for the maximum wash cycle time.

- Verify incoming water meets minimum temperature and pressure specification.
- Adjustment of rinse tank differential set point may be needed (see screen #7).
- Not applicable for AVENGER LT-E Models.

Fault 5: Indicates fault 4 has been activated for 5 consecutive cycles.

- If fault #5 is active contact technical service for assistance.
- Not applicable for AVENGER LT-E Models.

Fault 6: Indicates the drain cycle has completed and the horizontal float switch is still active.

- Verify standpipe is removed prior to turning machine off.
- Verify water level. If high and standpipe is removed verify there are no clogs in drain line.

\* Faults 2 and 5 will prevent the unit from cycling.

**SCREEN 3: FILL CYCLE TIMERS** The “Fill Cycle Timers” screen allows the user to edit the fill, detergent and rinse aid timers for the initial fill cycle.

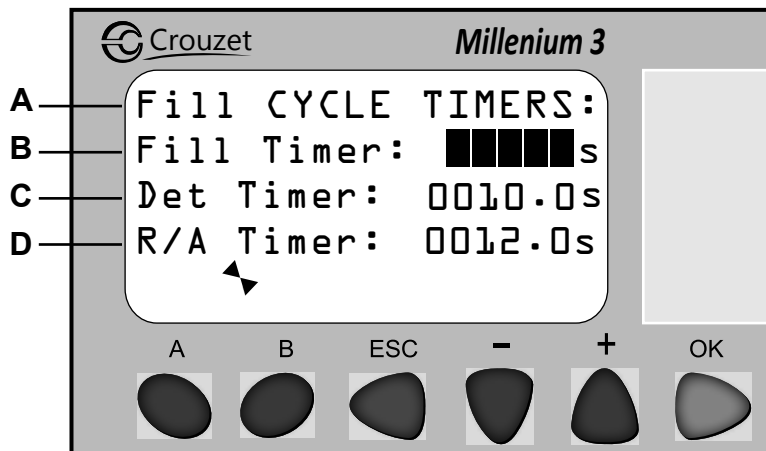

1. Line B displays the fill time.
  - Press + or - to highlight line B.
  - Press OK to enter highlight mode for line B.
  - Press + or - to make any adjustments needed.
    - \* **Fill Time: 5 to 20 seconds.**
  - Press OK to confirm adjustments.
  
2. Line C shows the detergent time.
  - Press the + or - to highlight line C.
  - Press “OK” to enter highlight mode.
  - Press + or - to make any adjustments needed.
    - \* **Detergent Time: 5 to 10 seconds.**
  - Press “OK” to confirm adjustments.
  
3. Line D displays the rinse aid time.
  - Press + or - to highlight line D.
  - Press OK to enter highlight mode.
  - Press + or - to make any adjustments needed.
    - \* **Rinse Aid Time: 0 to 12 seconds.**
  - Press OK to confirm adjustments.



**SCREEN 4: WASH CYCLE TIMERS 1** Screen 4 is the first “Wash Cycle Timers” screen and allows the user to edit the wash, rinse and drain timers for the initial wash cycle.

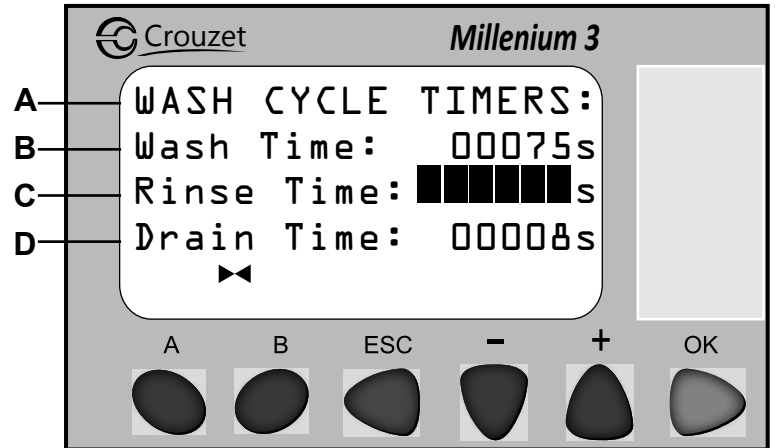

1. Line B shows the wash time.
  - Press + or - to highlight line B.
  - Press OK to enter highlight mode.
  - Press + or - to make any adjustments needed.
    - \* **Wash Time: 75 to 268 seconds.**
  - Press OK to confirm adjustments.
2. Line C shows the rinse time.
  - Press + or - to highlight line C.
  - Press OK to enter highlight mode.
  - Press + or - to make any adjustments needed.
    - \* **Rinse Time: 8.5 to 13 seconds.**
  - Press OK to confirm adjustments.
3. Line D shows the drain time.
  - Press + or - to highlight line D.
  - Press OK to enter highlight mode.
  - Press + or - to make any adjustments needed.
    - \* **Drain Time: 8 to 15 seconds.**
  - Press OK to confirm adjustments.

**SCREEN 5:  
WASH CYCLE  
TIMERS 2**

Screen 5 is the second "Wash Cycle Timers" screen and allows the user to edit the detergent and rinse aid timers for the initial wash cycle.

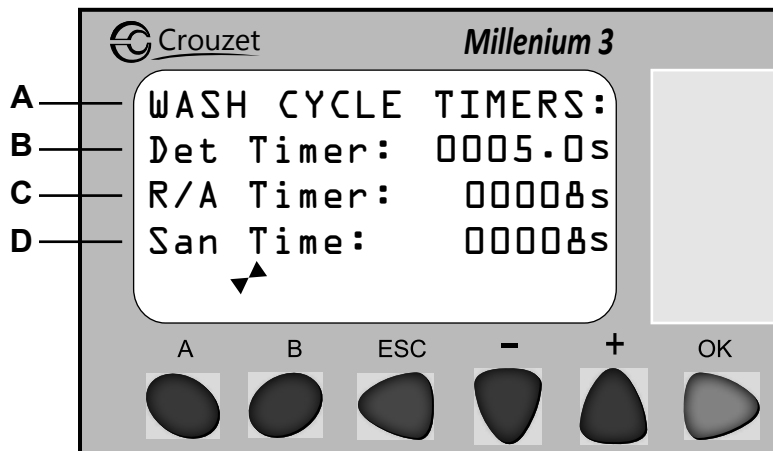

1. Line B shows the detergent time.
  - Press + or - to highlight line B.
  - Press OK to enter highlight mode.
  - Press + or - to make any adjustments needed.
    - \* **Detergent Time: 5 to 10 seconds.**
  - Press OK to confirm adjustments.
  
2. Line C shows the rinse aid time.
  - Press + or - to highlight line C.
  - Press OK to enter highlight mode.
  - Press + or - to make any adjustments needed.
    - \* **Rinse Aid Time: 8 to 12 seconds.**
  - Press OK to confirm adjustments.
  
3. Line D will display the sanitizer time (only shown on Avenger LT-E )
  - Press + or - to highlight line D.
  - Press OK to enter highlight mode.
  - Press + or - to make any adjustments needed.
    - \* **Sanitizer Time: 5 to 10 seconds.**

**SCREEN 6: TEMPERATURE SETPOINTS** Screen 6 is the "Temperature Setpoints" screen and allows the user to edit the wash tank, top rinse tank and bottom rinse tank temperatures.

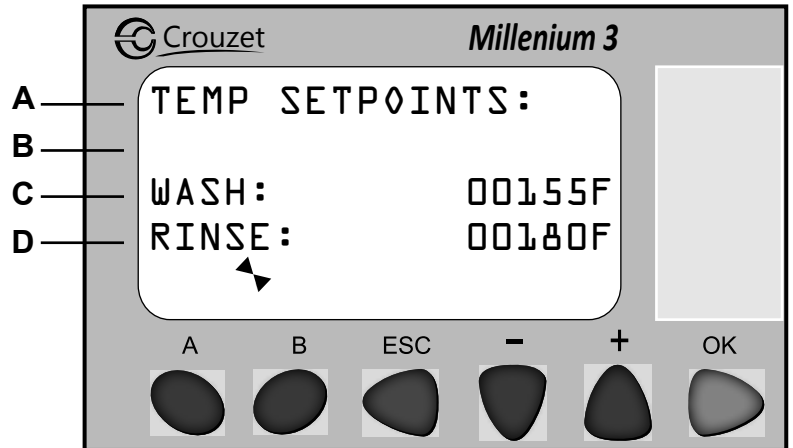

1. Line C shows the wash tank temperature.
  - Press + or - to highlight line B.
  - Press OK to enter highlight mode.
  - Press + or - to make any adjustments needed.
    - \* **HT-E Wash Tank Temperature: 155°F to 175°F (68°C to 79°C).**
    - \* **LT-E Wash Tank Temperature: 115°F to 130°F (46°C to 54°C).**
  - Press OK to confirm adjustments.
  
2. Line D shows the rinse tank temperature.
  - Press + or - to highlight line C.
  - Press OK to enter highlight mode.
  - Press + or - to make any adjustments needed.
    - \* **Rinse Tank Temperature: 170°F to 190°F (77°C to 88°C).**
  - Press OK to confirm adjustments.

**SCREEN 7:  
SANISURE SELECT**

The "SaniSure Select" screen allows the user to turn SaniSure on or off. SaniSure ensures the rinse temperatures are high enough to achieve sanitization.

Not applicable for AVENGER LT-E Models.

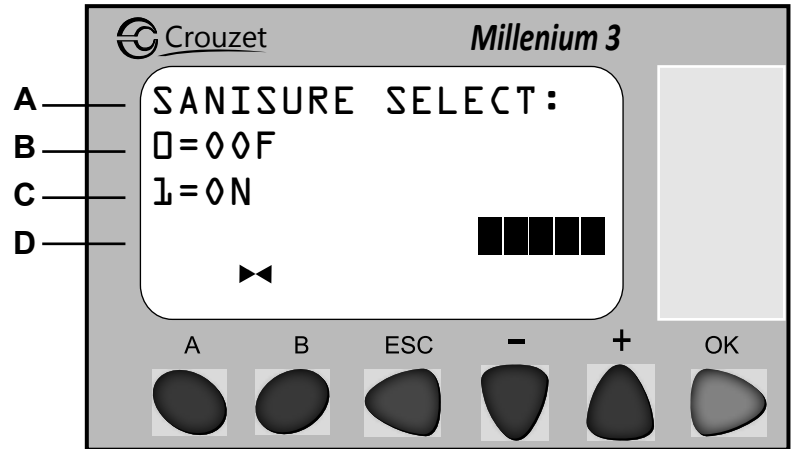

1. Line B shows the off option.
  - Press + or - to highlight line B.
  - Press OK to turn SaniSure off and reset fault 5.
  
2. Line C shows the on option.
  - Press + or - to highlight line C.
  - Press OK to turn SaniSure on.
  
3. Line D will display the SaniSure status.

**SCREEN 8: RINSE TANK TEMPERATURES** The "Rinse Tank Temperatures" screen allows the user to see the temperature readings in the top and bottom rinse tanks.  
 Not applicable for AVENGER LT-E Models.

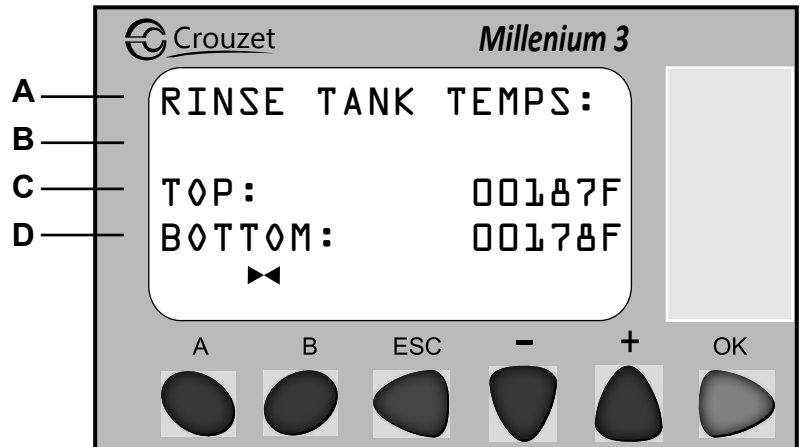

1. Line C shows the current temperature reading of the top booster tank.
2. Line D shows the current temperature reading of the bottom booster tank.

**SCREEN 9: WASH CYCLE COUNT** The "Wash Cycle Count" screen allows the user to see the number of cycles since the last complete tub drain and edit the number of cycles that perform before the "flush" light activates.

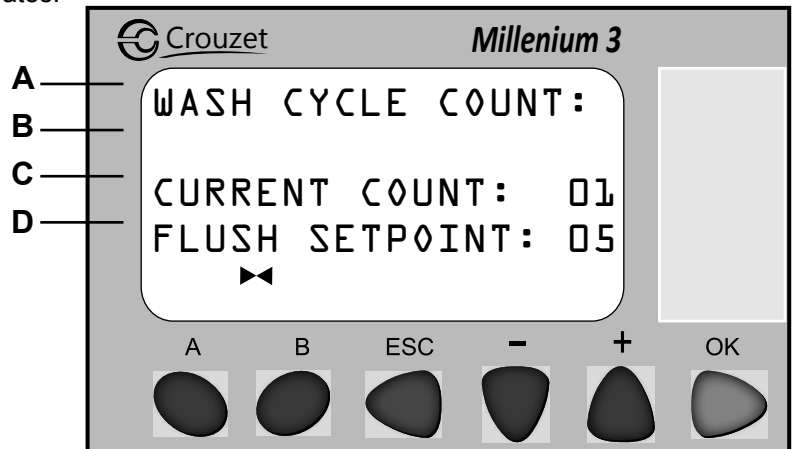

1. Line C displays the number of cycles since the last "flush" or complete tub drain.
2. Line D shows the number of cycles that perform before the "flush" light activates.
  - Press + or - to highlight line D.
  - Press OK to enter highlight mode.
  - Press + or - to make any adjustments needed.
    - \* **Flush Setpoint: 5 to 30**
  - Press OK to confirm adjustments.
  - When flush light is activated, user should remove the standpipe and drain the tub.

**SCREEN 10:  
TEMPERATURE  
SELECT**

The temperature select screen allows the user to select how temperatures are read, either in celsius or fahrenheit.

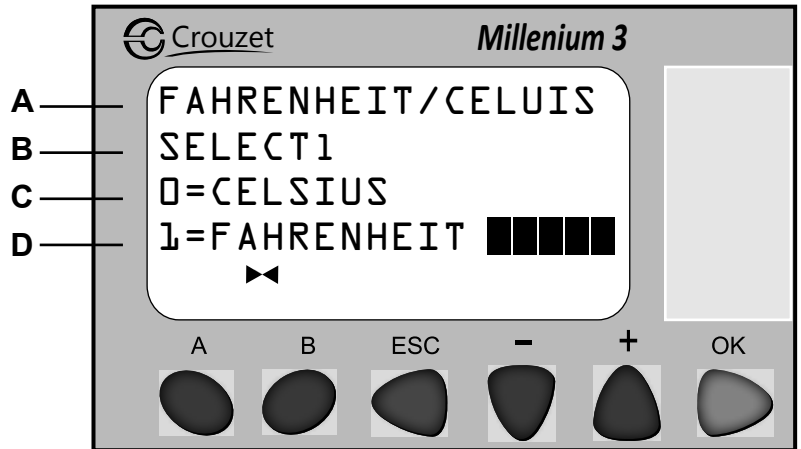

1. Line C shows the celsius option.
  - Press + or - to highlight line C.
  - Press OK to allow display to read temperatures in celsius.
2. Line D shows the fahrenheit option.
  - Press + or - to highlight line D.
  - Press OK to allow display to read temperatures in fahrenheit.

**SCREEN 11:  
INPUT/OUTPUT**

The input/output screen shows inputs and outputs that are active.

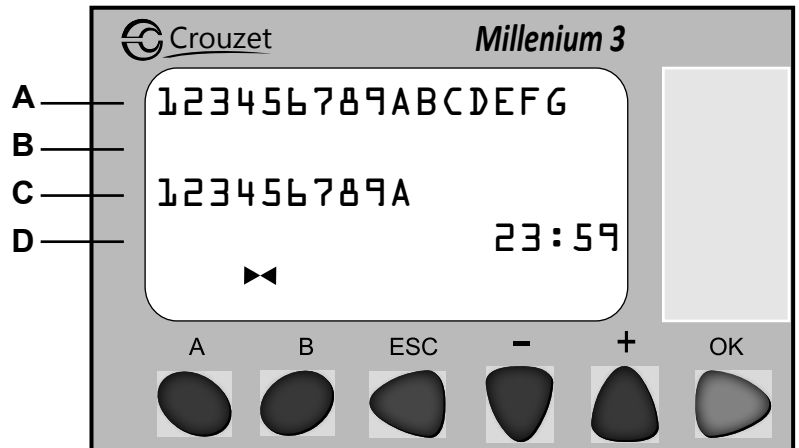

1. Line A (inputs) will highlight when the connected component sends a signal to the PLC. Multiple inputs may be highlighted at the same time.
2. Line C (outputs) will highlight when the PLC closes specific relays. Multiple outputs may be highlighted at the same time.

**SCREEN 12:** Screen 13 shows the wash, rinse injector, pressure and temperature readings.  
**WASH,  
 RINSE INJECTOR,  
 PRESSURE &  
 TEMPERATURE  
 READINGS**

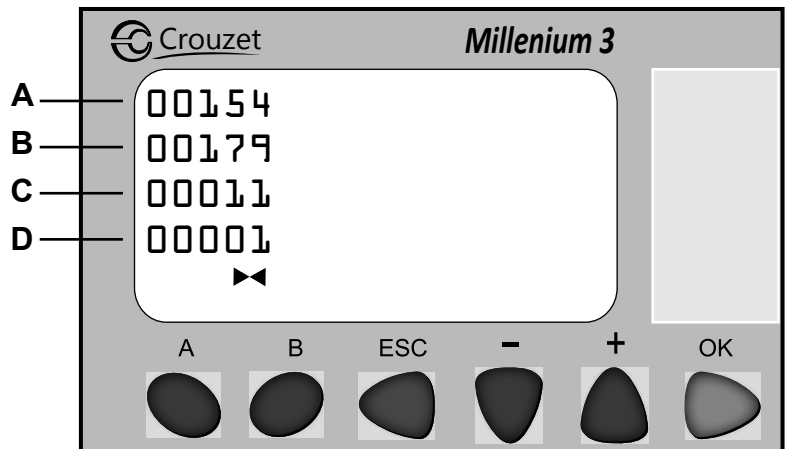

1. Line A shows a reading of the wash RTD.
2. Line B shows a reading of the rinse injector RTD.
3. Line C shows a reading from the pressure transducer.
4. Line D shows if temperature is displaying in celsius (1) or fahrenheit (0).

**SCREEN 13:** The "Reset to Factory" screen allows user to reset the machine to factory default settings.  
**RESET TO FACTORY**

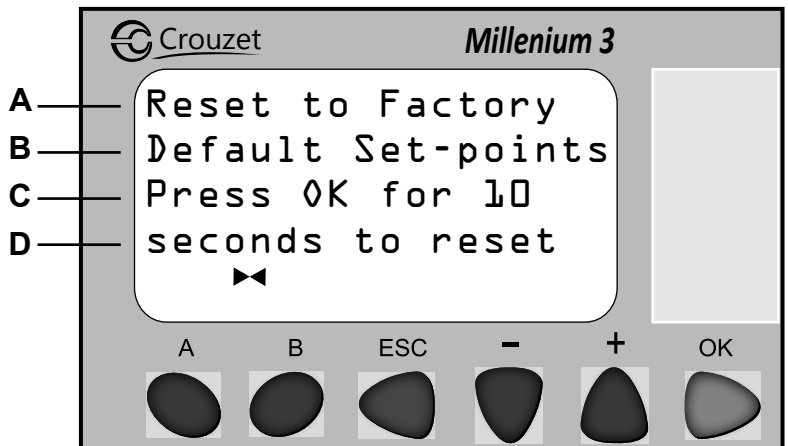

1. Press OK for 10 seconds on screen 13 to reset timer to default settings.

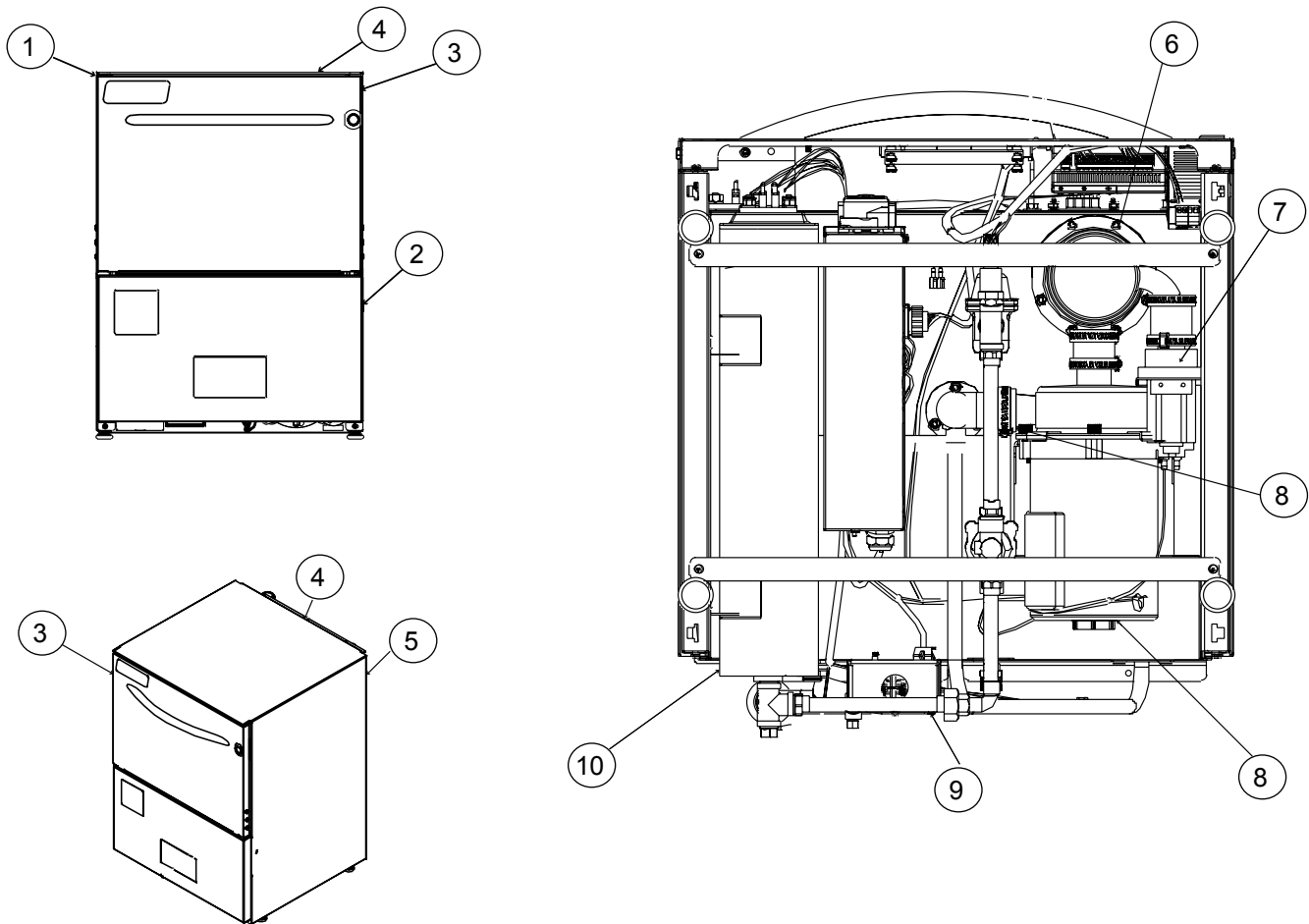

ITEM	QTY	DESCRIPTION	PART NUMBER
1	1	Left, Shroud	05700-003-37-04
2	1	Kick Panel Assembly (see pg. 28)	05700-004-05-62
3	1	Door Assembly (see pg. 32)	05700-004-04-21
4	1	Shroud Top	05700-003-37-06
5	1	Shroud Right	05700-003-37-05
6	1	Sump (see pg. 34)	05700-004-02-94
7	1	Drain Pump (see pg. 34)	04730-003-91-41
8	1	Wash Motor Assembly (see pg. 34)	05700-004-04-04
9	1	Terminal Block Box Cover (see pg. 26)	05700-003-27-70
10	1	Booster Assembly	05700-004-01-15



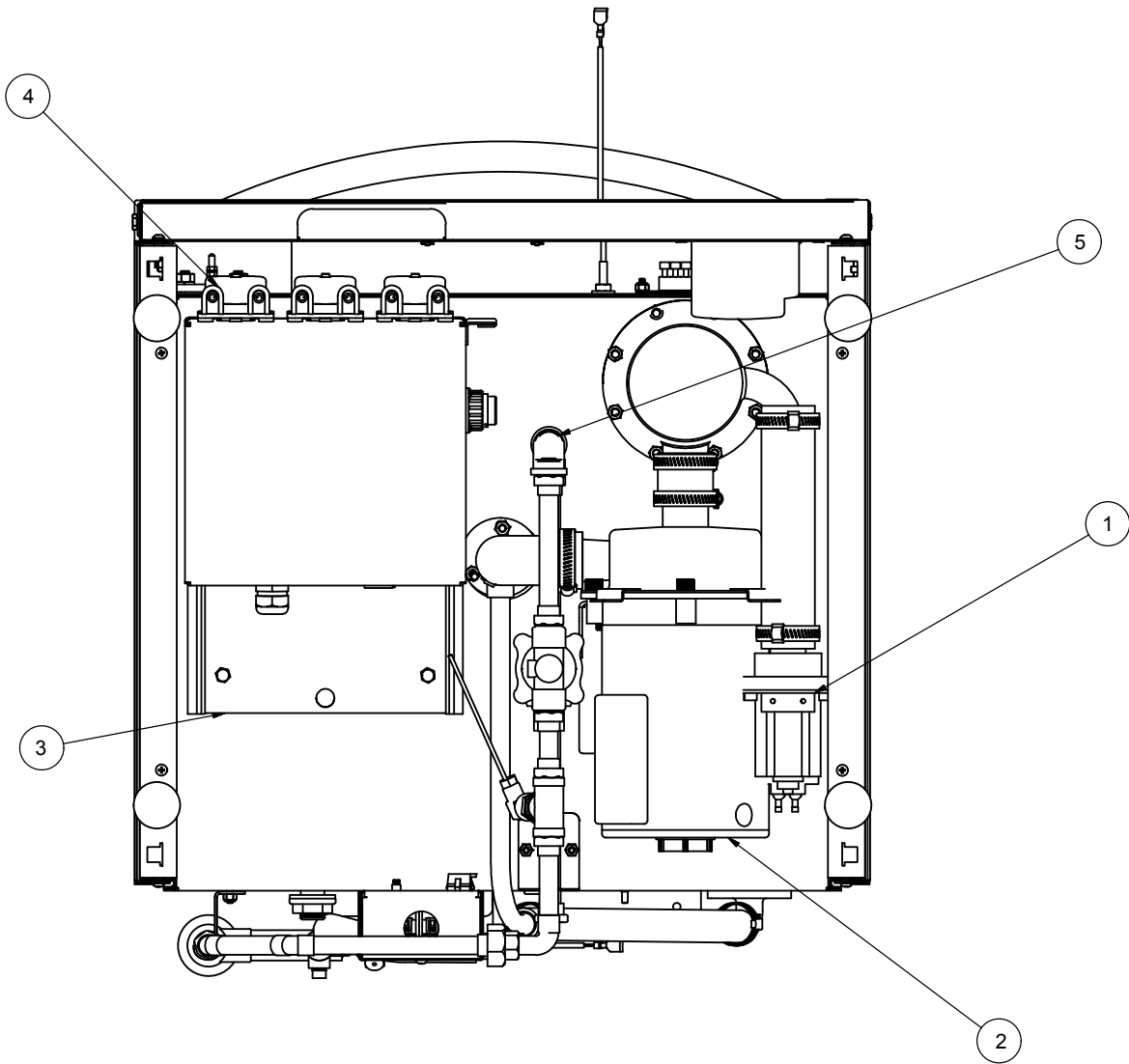

ITEM	QTY	DESCRIPTION	PART NUMBER
1	1	Drain Pump	04730-004-18-89
2	1	Pump Assembly w/ Mounting Bracket and Hoses	05700-004-04-04
3	1	F-Channel, Control Box LT-E	05700-004-12-01
4	1	Control Box Slide 115V	05700-004-11-52
5	1	Plumbing Assembly	05700-004-18-93

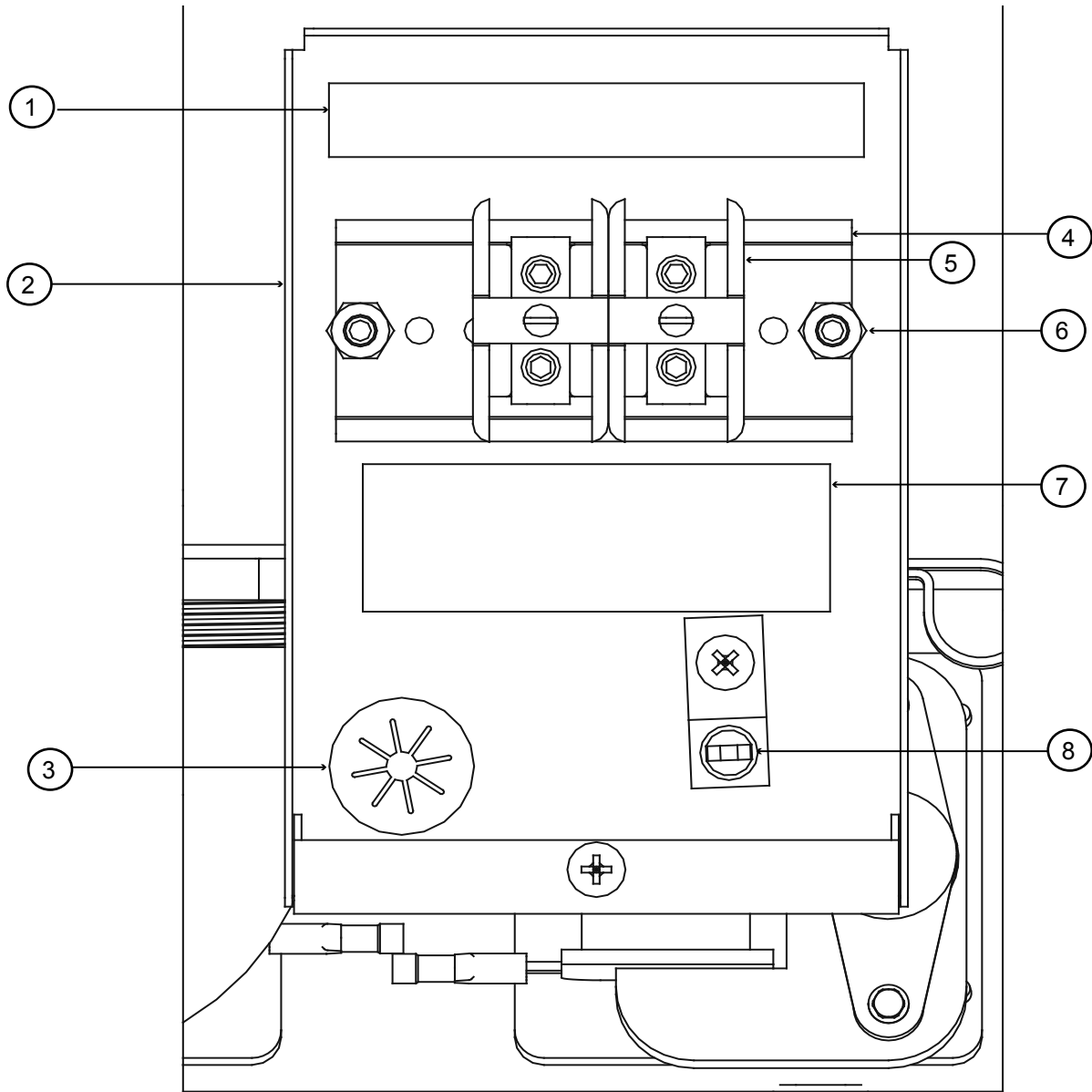

ITEM	QTY	DESCRIPTION	PART NUMBER
1	1	Decal, Power Connection	09905-011-47-35
2	1	Terminal Block Box	05700-003-27-69
	1	Terminal Box Cover (not shown)	05700-003-27-70
3	1	Strain Relief	05975-003-37-56
4	1	Terminal Block Track	05700-000-43-60
5	2	Terminal Block	05940-500-02-19
6	2	10-24 Lock Nut	05310-373-01-00
7	1	Decal, Copper Conductors	09905-011-62-72
8	1	Ground Lug	05940-200-76-00

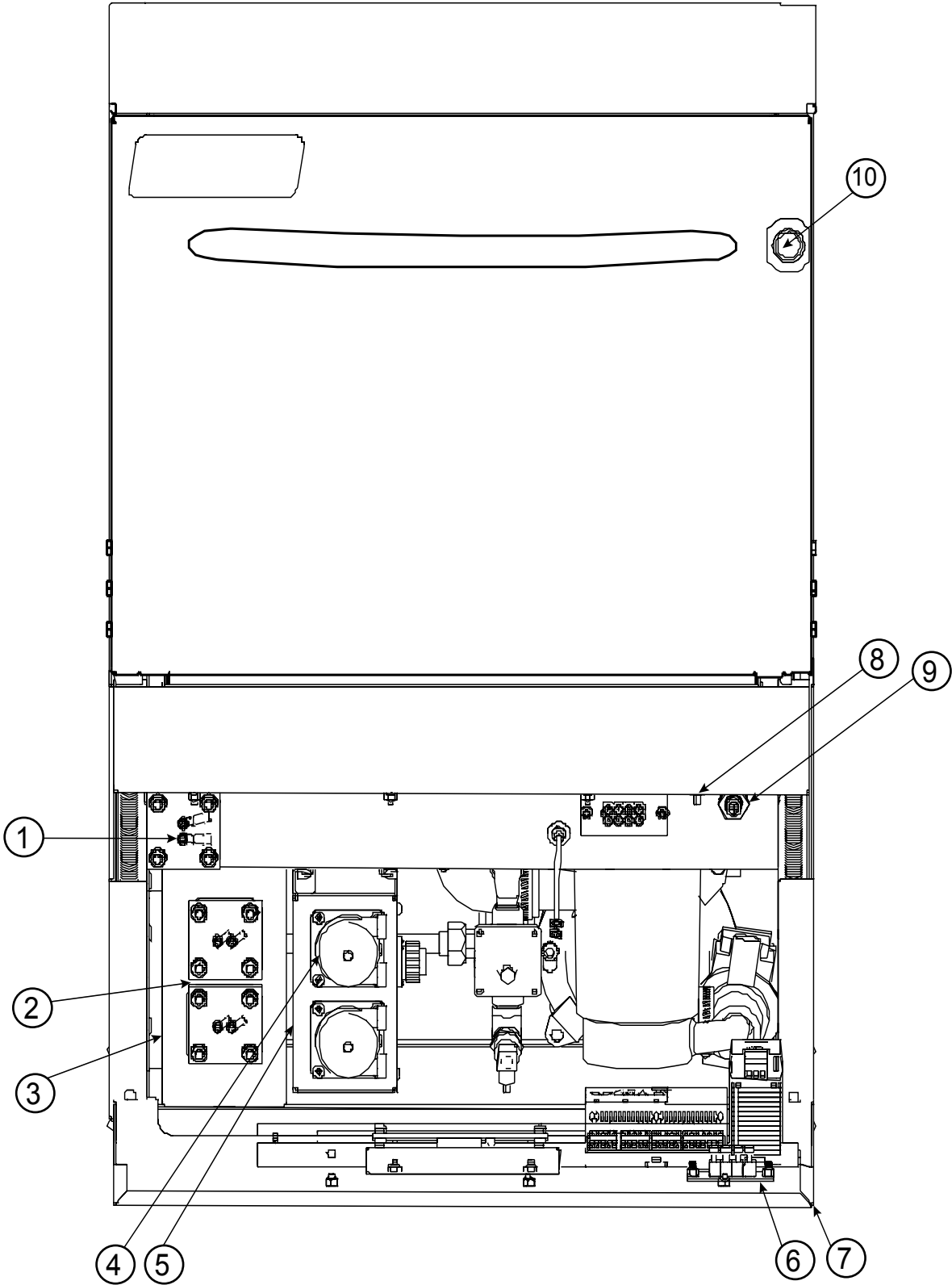

ITEM	QTY	DESCRIPTION	PART NUMBER
1	1	Wash Heater 4KW	04540-003-99-44
	1	**480V Heater	04540-004-12-29
	1	Wash Heater 1.5KW 115V (AVENGER LT-E Only)	04540-004-11-48
2	3	Heater Gasket	05330-100-01-10
	1	**480V Heater Gasket	05330-004-13-19
3	1	Rinse Booster (see page 40, Rinse Tank Assembly)	05700-004-01-15
4	1	Pump Cover, Rinse Aid	04320-004-10-38
5	1	Control Box (see page 31 & 32)	05700-004-09-05
6	1	Terminal Board	05940-021-94-65
7	1	Kick Panel (see page 30)	05700-004-04-28
8	1	Vertical Float Switch	05930-011-48-98
9	1	Horizontal Float Switch	06680-004-05-50
10	1	Start Button	05930-004-04-22

\*\* Models with 480V Control Box

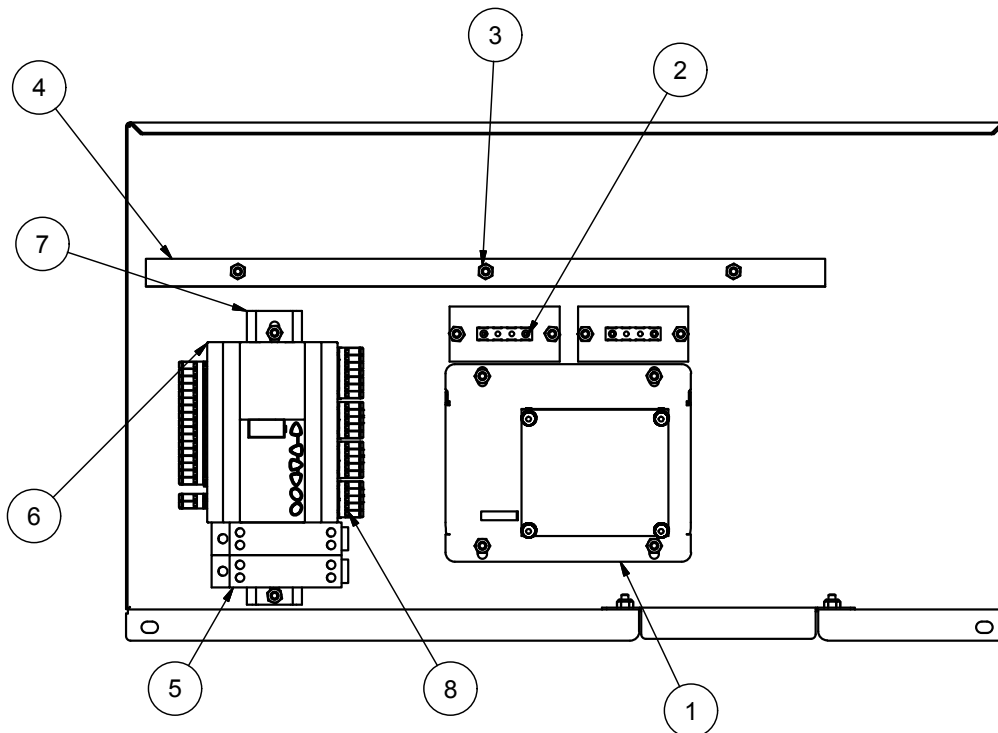

ITEM	QTY	DESCRIPTION	PART NUMBER
		Control Kick Panel Complete Assembly	05700-004-05-62
1	1*	Control Panel, Avenger LT-E	05700-004-18-99
	1	A-Control Panel, Avenger HT-ES	05700-004-00-10
2	2	Terminal Board, 4 POS JM96054	05940-021-94-85
3	16	Nut, Lock 10-24 S/S Hex w/ Nylon Insert	05310-373-01-00
4	1	Cover, Control Dielectric	05700-004-06-12
5	2	Power Supply, 100-240VAC 12 DC 1.2A 15 Watt	05950-004-11-16
6	1	PLC Programmed, Avenger HT-E	05700-004-17-68
	1*	PLC Programmed, Avenger LT-E	05700-004-22-05
7	2	Din Rail, 8" Long	05700-004-09-42
8	2	Terminals, 88970317 M3 MA SET XD26 RBT	05940-021-94-85
9	1	W- Kick Panel, Avenger HT ES	05700-004-04-28
10	1	F-Cover, Kick Panel	05700-004-11-27

\* AVENGER LT-E Only

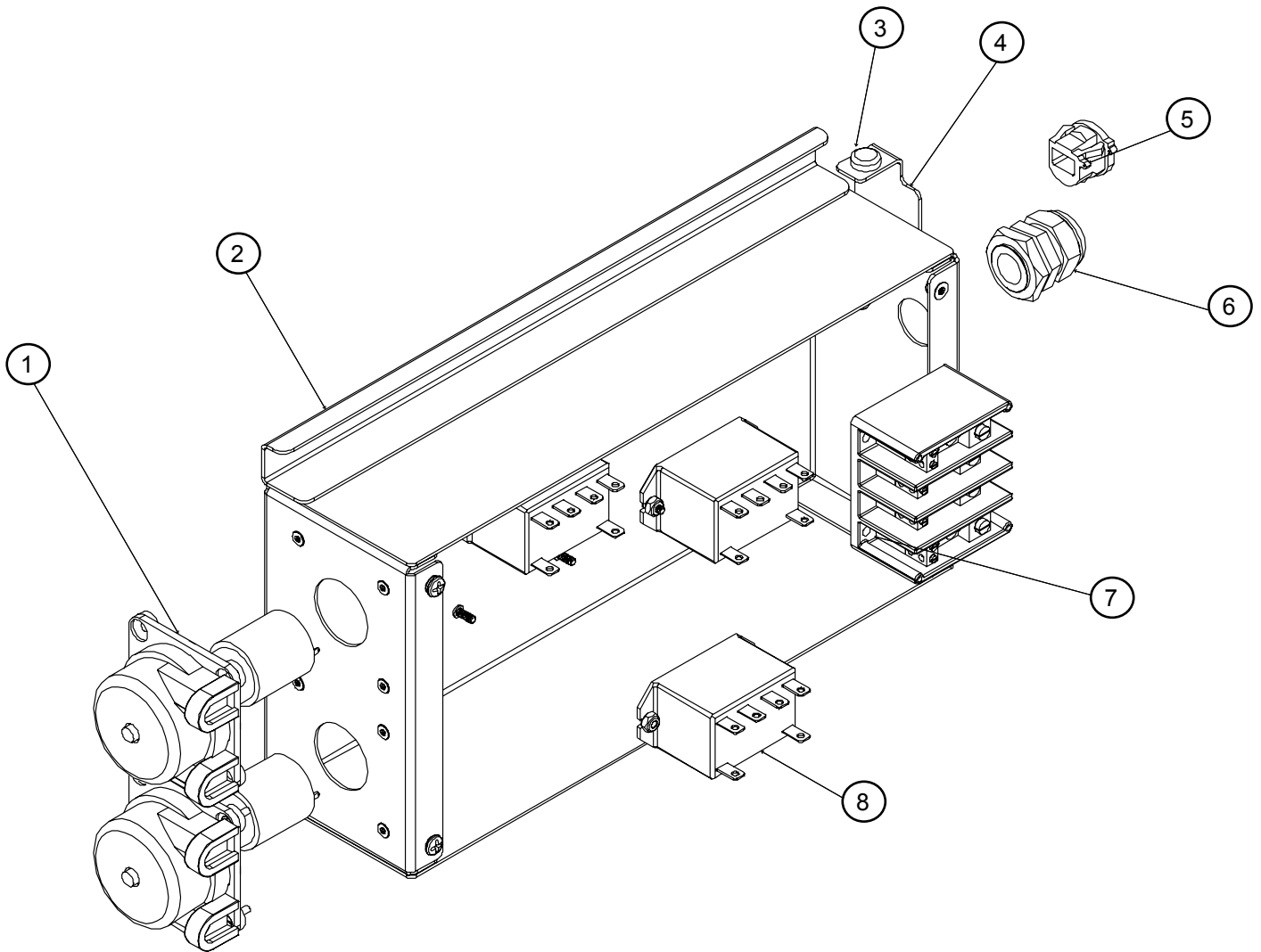

ITEM	QTY	DESCRIPTION	PART NUMBER
1	2	Peripump, 36 RPM, 24VDC	04320-004-09-56
2	1	Control Box	05700-004-09-04
3	1	Wear Button, .50 Diameter	05700-011-88-01
4	1	Control Box Rest Bracket	05700-004-09-28
5	1	Strain Relief	05975-003-37-56
6	1	Fitting .3219, .25/.546	05975-011-65-51
7	1	Block	05945-002-42-24
8	4	Relay	05945-004-10-48
	1	Clamp (not shown)	04730-011-39-01
	1	Cover, Control Box Avenger HT-E (not shown)	05700-004-09-45

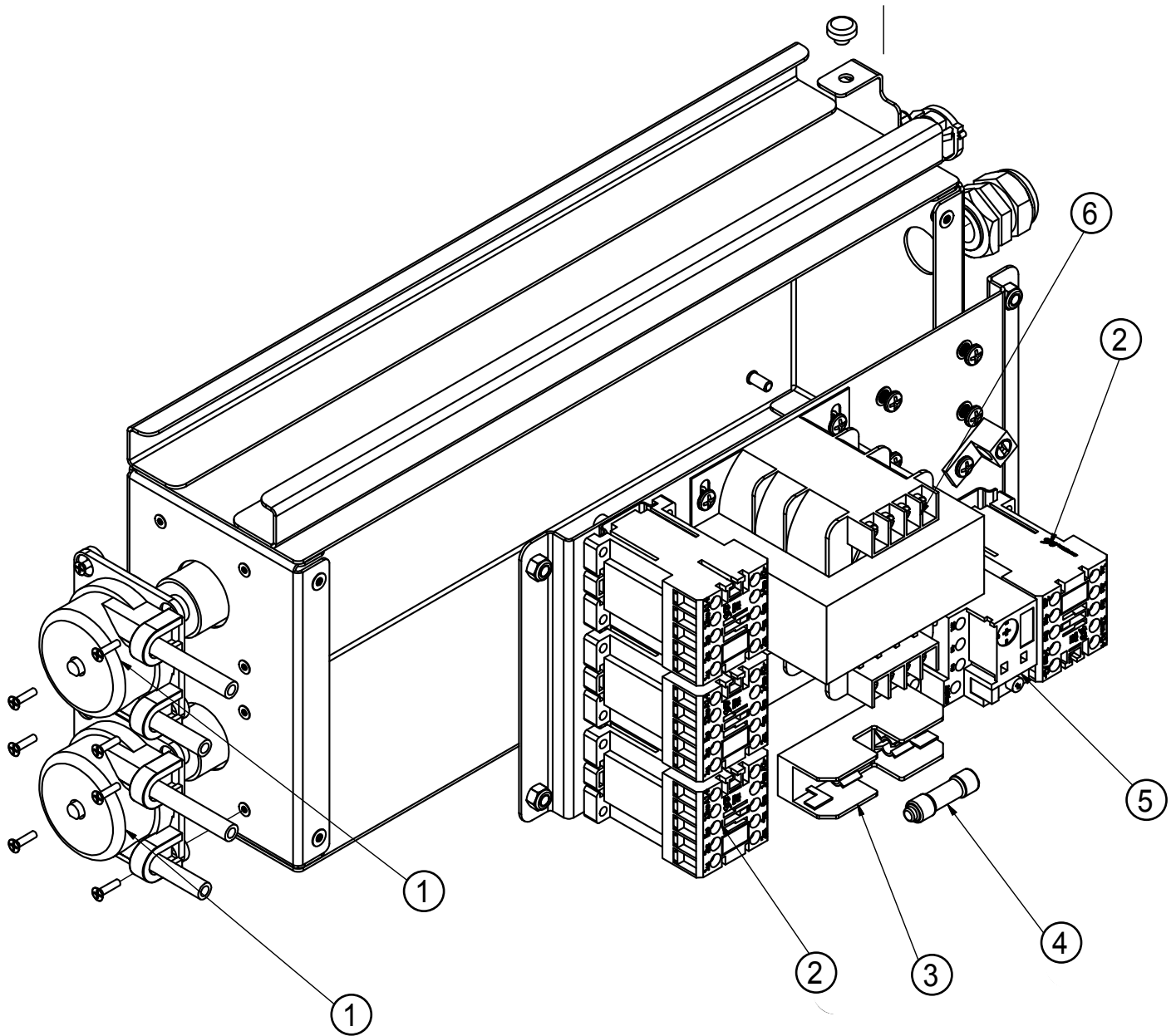

ITEM	QTY	DESCRIPTION	PART NUMBER
1	2	Peripump, 36 RPM 24VDC	04320-004-09-56
2	4	Contactors, 24 VDC, 460V Max, 5HP	05945-003-75-22
3	1	Holder, BM6031SQ SINPO Fuse Bussman	05920-011-72-89
4	1	Fuse, 1/2 Amp FNQ-R-1/2 Bussman	05920-011-72-88
5	1	Overload, 10=14A, 600VAC Max, 5HP	05945-003-75-17
6	1	Transformer 150 VA 50/80 Hz	05950-011-50-70

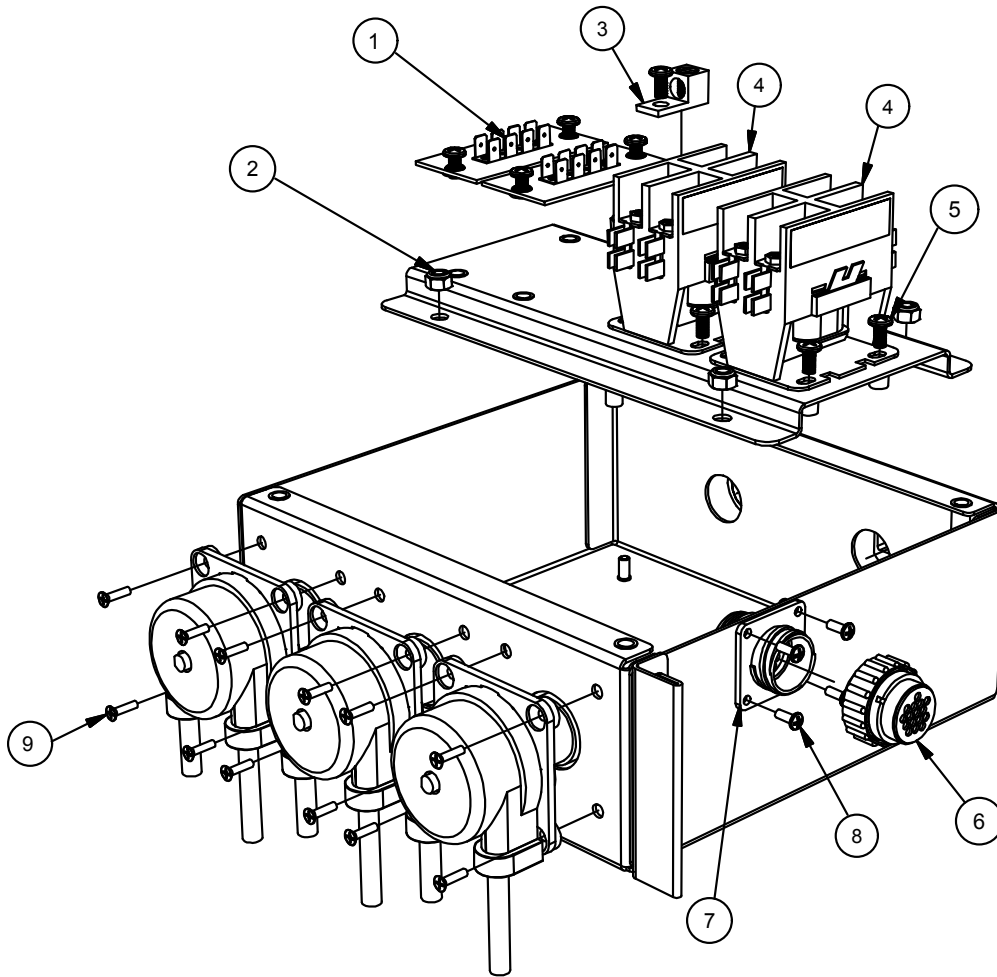

ITEM	QTY	DESCRIPTION	PART NUMBER
		Control Box Assembly	05700-004-11-52
1	2	Terminal Board	05940-021-94-85
2	4	Nut, Lock 10-24 S/S Hex	05310-373-01-00
3	1	Lug, Panduit Ground	05940-200-76-00
4	2	Contactors, GE 110V	05945-109-05-69
5	17	Screw, 10-32 X 3/8 Phillips Pan HD	05305-173-26-00
6	1	Multimate Socket	05940-002-31-33
7	1	Connector, SQ Receptacle	05940-002-31-33
8	4	Screw, 3/8 Pan Head	05305-171-02-00
9	12	Screw, 6-32 X 1/2"	05305-002-74-99
		Cover, Control Box Avenger LT-E (not shown)	05700-004-11-54



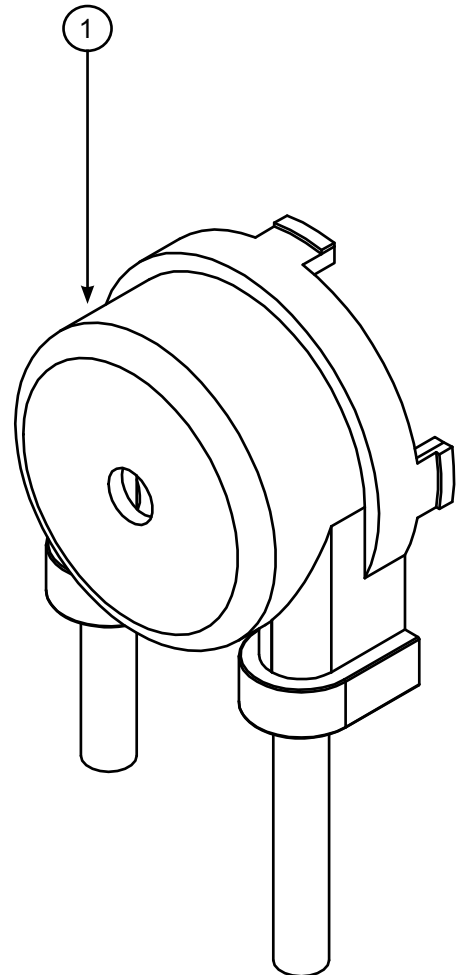
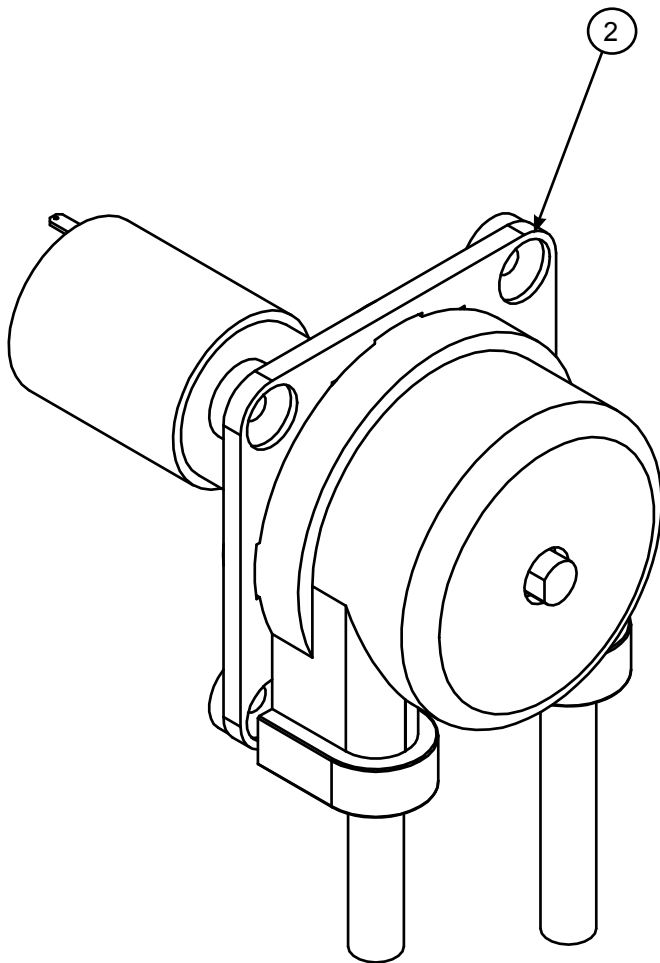

ITEM	QTY	DESCRIPTION	PART NUMBER
1	2	Chemical Pump w/Squeeze Tube	04320-004-10-39
2	2	Chemical Pump Complete Assembly w/Motor	04320-004-09-56

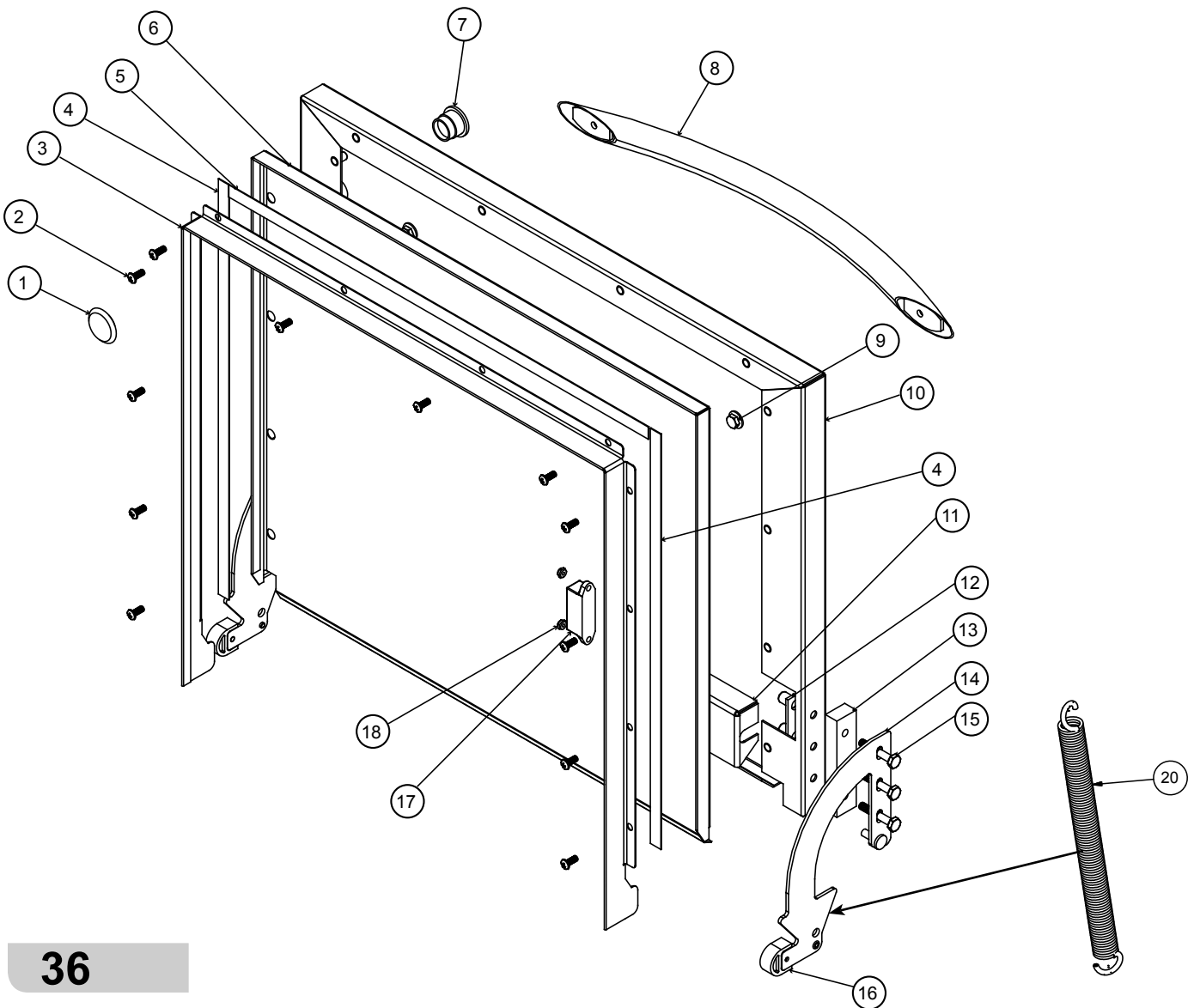
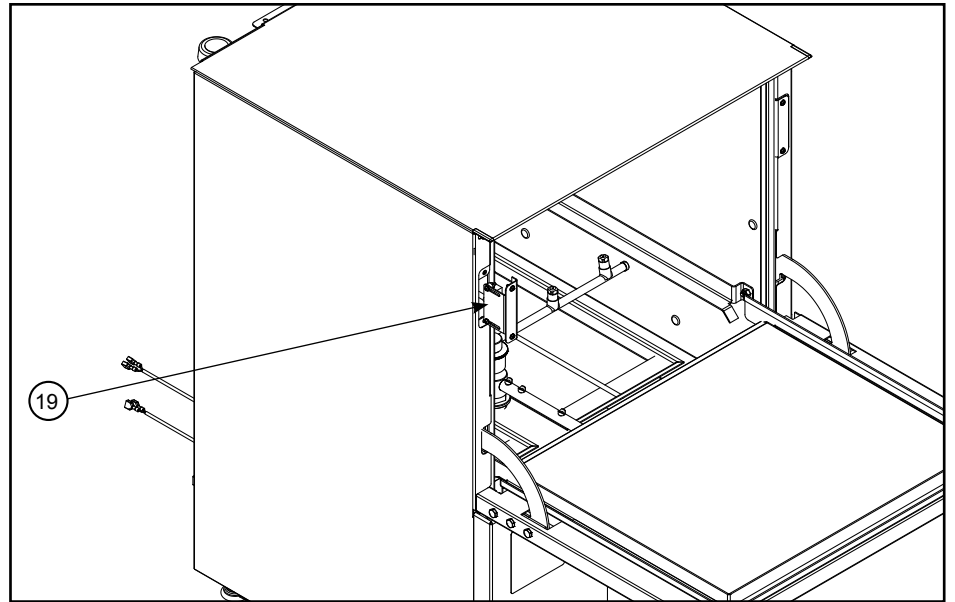

ITEM	QTY	DESCRIPTION	PART NUMBER
1	1	Flush Mount Plug	05975-004-04-36
2	12	10-32 x 1/2" Phillips Pan Head Screw	N/A
3	1	Door Channel Seal	05700-003-55-49
4	2	Left & Right Door Gasket	05330-003-58-36
5	1	Top Door Gasket	05330-003-58-35
6	1	Inner Door	05700-004-08-31
7	1	Start Button	05930-004-04-22
8	1	Door Handle	05700-003-26-62
9	2	1/4-20 x 3/8" Hex Head Bolt	N/A
10	1	Outer Door Weldment	05700-003-33-37
11	1	Door Baffle	05700-003-33-38
12	2	Retaining Plate	05700-011-44-37
13	2	Hinge Spacer	05700-003-33-42
14	1	Left Hinge Weldment	05700-003-32-71
15	6	1/4-20 x 1-1/2" Hex Head Screw	N/A
16	2	Door Hinge Stop	05700-003-32-55
17	1	Door Magnet	05930-002-88-42
18	2	6/32 Locknut	N/A
	1	Right Hinge Weldment (not shown)	05700-003-32-72
	2	10-32 x 1/4" Screw (not shown)	N/A
	2	Washer (not shown)	05311-174-01-00
19	1	Door Safety Reed Switch	05930-003-31-44
20	2	Door Spring Assembly	05700-003-32-85
21	1	Cable, 2 Wire AVG Door Switch	05700-004-08-26

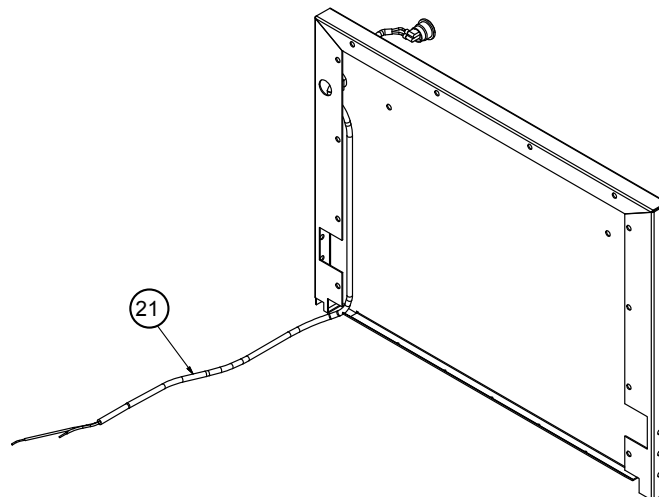

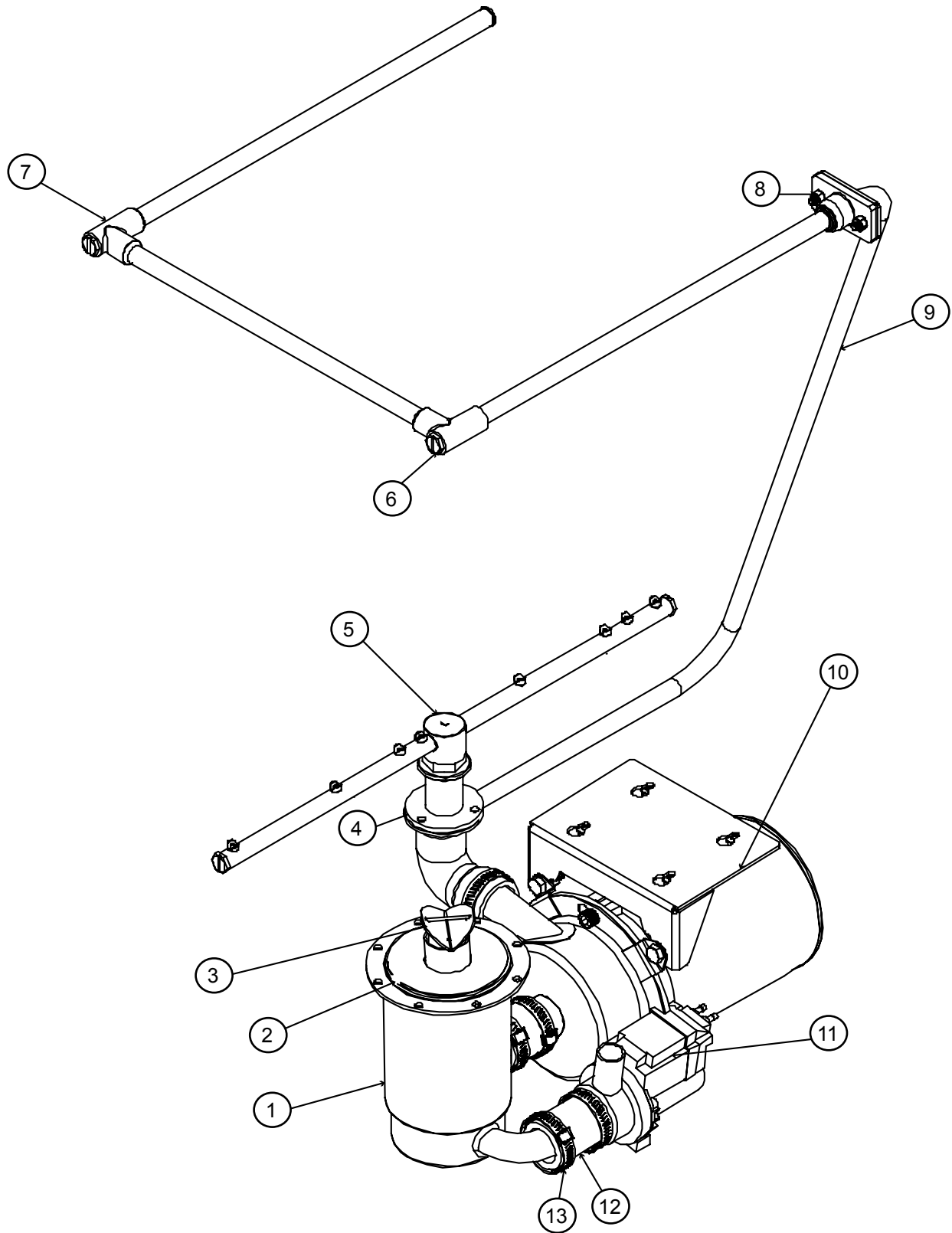

# WASH & DRAIN MOTOR ASSEMBLY

## PARTS

ITEM	QTY	DESCRIPTION	PART NUMBER
1	1	Sump	05700-004-02-94
2	1	Sump Strainer	05700-004-03-73
3	1	Stand Pipe	05700-004-04-40
4	1	Manifold Gasket	05330-002-34-77
5	2	Wash Arm Assembly	05700-021-39-23
6	2	Wash Arm Plug, ES2000	05700-011-35-92
7	1	Wash Halo	05700-004-03-22
8	41	Locknut, 1/4-20 Hex w/Nylon Insert	N/A
9	1	Wash Manifold	05700-004-08-96
10	1	Pump Assembly w/Mounting Bracket and Hoses	05700-004-04-04
11	1	Drain Pump	04730-003-91-41
	1	Drain Pump 115V	04730-004-18-89
12	1	Drain Hose	05700-004-08-21
13	3	Clamp, Reg. Range 1-1/16 to 2 HS24	04730-719-18-00

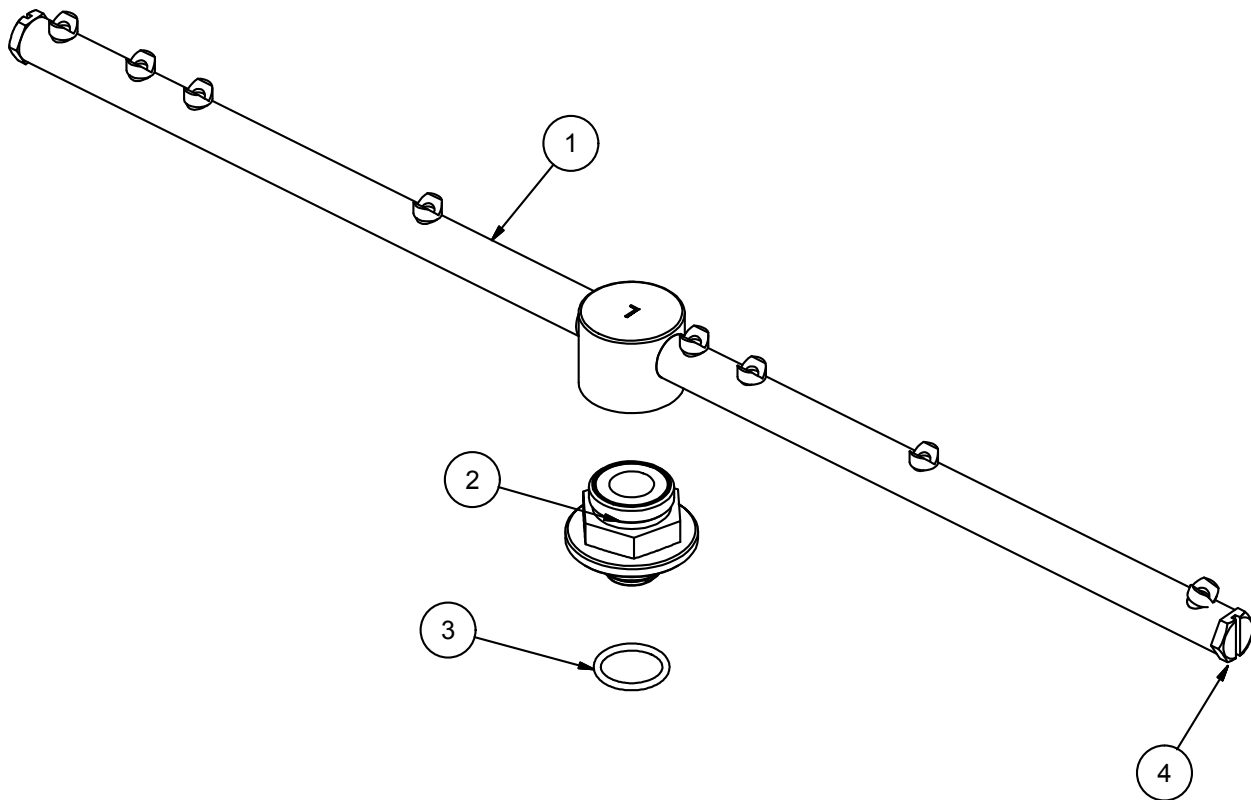

ITEM	QTY	DESCRIPTION	PART NUMBER
		Complete Wash Arm Assembly	05700-021-39-23
1	1	Wash Arm w/Plug	05700-021-46-58
2	1	Bearing, Assembly	05700-021-35-97
3	1	O-Ring	05330-002-60-69
4	1	End Plugs	05700-011-35-92

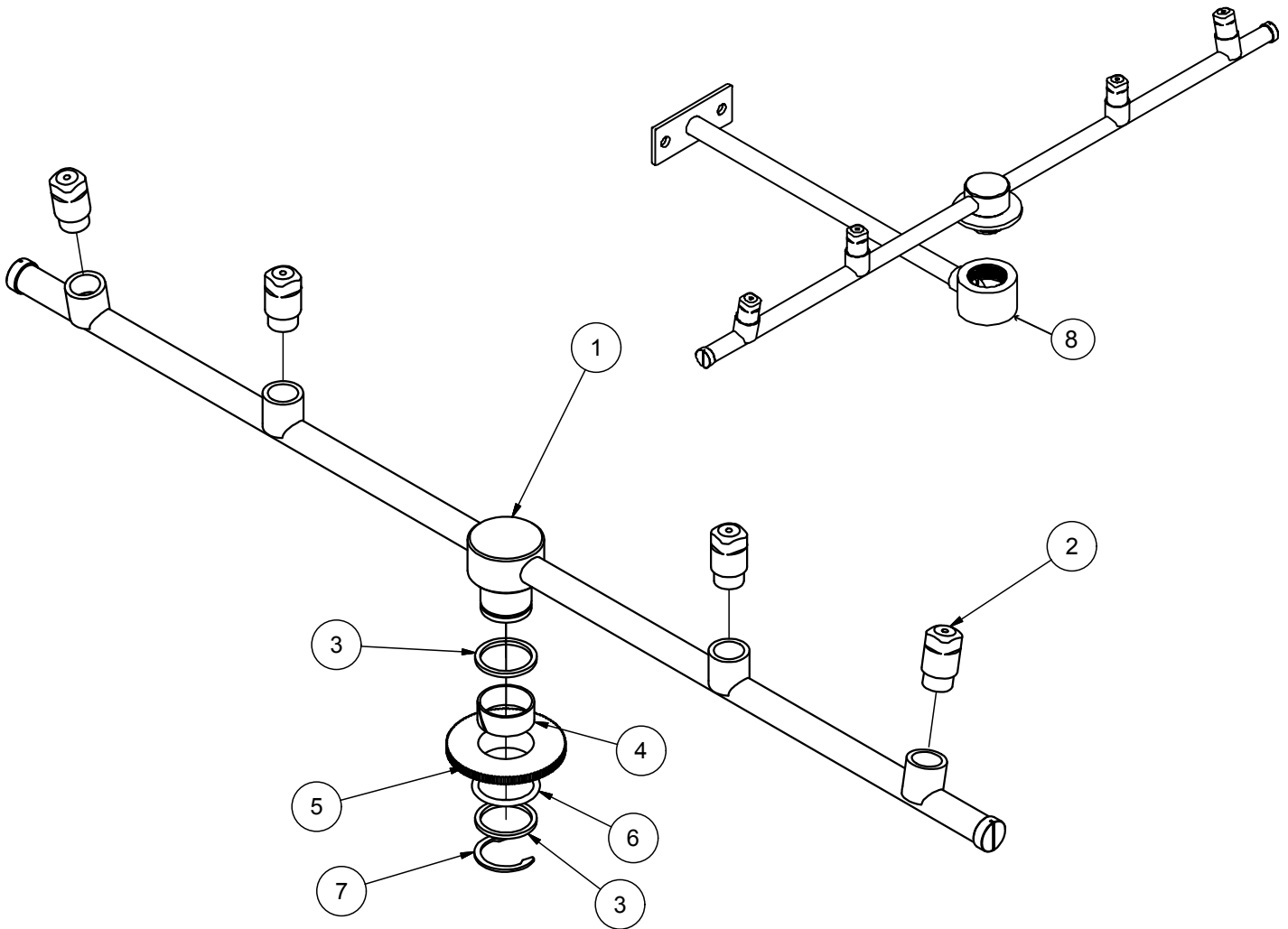

ITEM	QTY	DESCRIPTION	PART NUMBER
	1	Complete Rinse Arm Assembly	05700-004-01-56
1	2	Rinse Arm, Plugs	05700-004-05-23
2	1	Nozzle	04730-004-01-07
3	1	Washer, Rinse Arm	05330-011-42-10
4	1	Bearing, Rinse Arm	03120-004-12-13
5	1	Bushing, Rinse Head	05700-021-33-84
6	1	O-Ring, Silicon	05330-002-60-69
7	1	Rinse, Retaining, Rinse Head Bushing	05340-112-01-11
8	1	Rinse Hub	05700-004-03-77

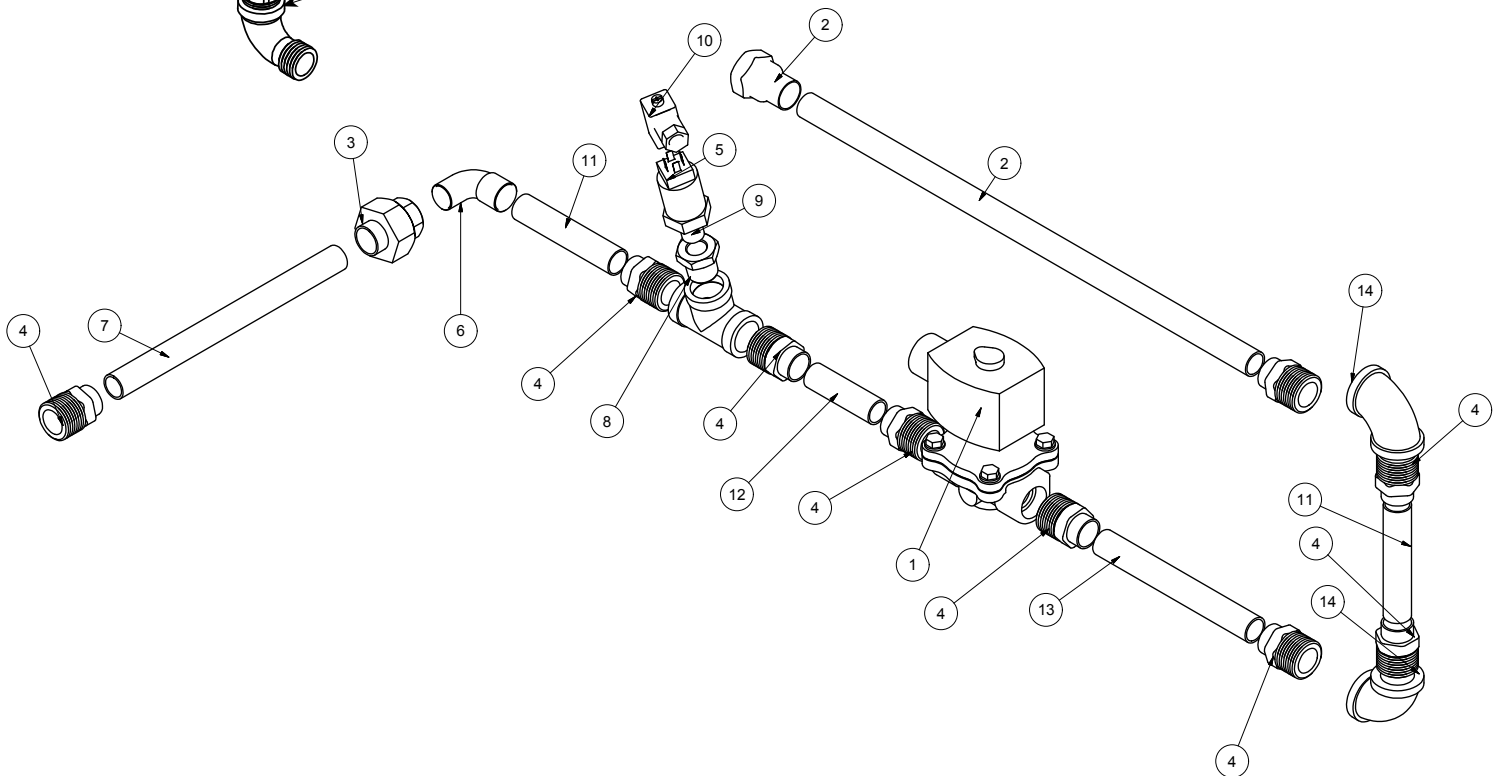
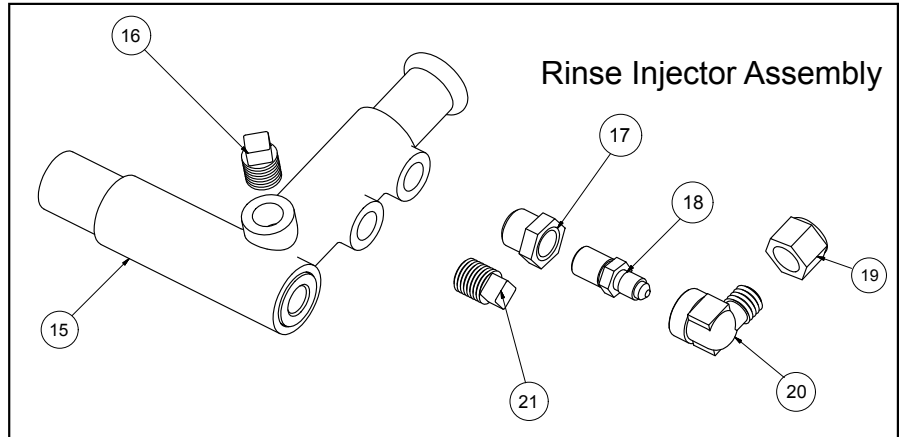
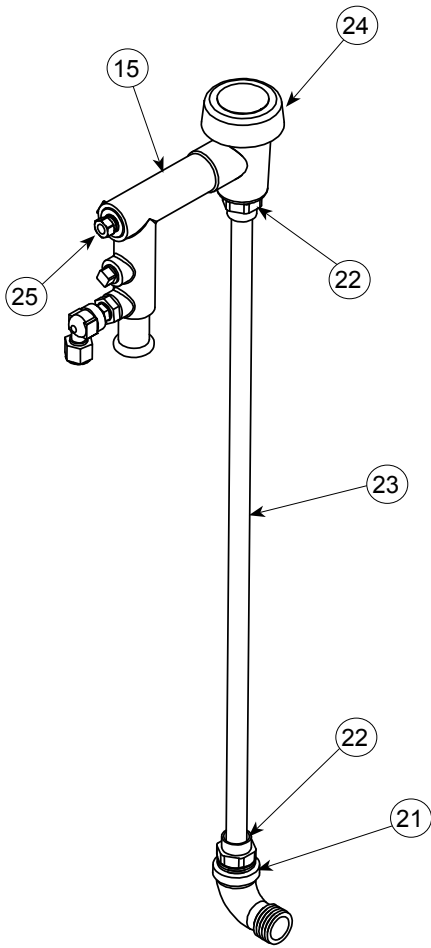



ITEM	QTY	DESCRIPTION	PART NUMBER
1	1	Vavle, 1/2" 208/60V	04810-003-71-56
	1	Valve, 1/2" 115V	04810-003-71-55
2	1	A-Plumbing, Inc to Reg, AVG HT ES	05700-004-04-44
3	1	Union, 1/2" (C/C) (733CAST)	04730-412-05-01
4	1	Adapter, Male (CU to MSPS)	04730-401-03-01
5	1	Transducer, Pressure 0-50 PSIG	05945-004-17-01
6	1	Elbow, 1/2 S. CU to FTG.	04730-406-31-01
7	1	F-Tube, Copper 1/2" x 7" Long	05700-002-13-81
8	1	Tee, 1/2" Brass	04730-211-27-00
9	1	Reducer, 1/2" x 1/4" Brass	04730-003-62-16
10	1	Harness, PTD Connection	05999-004-21-58
11	1	F-Tubing, Copper 1/2 x 3	05700-001-05-21
12	1	F-Tube, 1/2 x 7 Copper	05700-001-04-66
13	1	F-Copper Pipe, 4.75" Long	04820-004-09-37
14	1	Elbow, 1/2 NPT90 Brass	05700-002-91-02
15	1	Rinse Injector	05700-004-08-29
16	2	Plug, 1/4	04760-209-01-00
17	1	Bushing, 1/4 x 1/8	04730-003-05-61
18	1	Check Valve	04820-111-51-14
19	1	Nut, Tube 1/8PP	04730-011-59-45
20	1	Fitting, Outlet Elbow	04820-111-51-18
21	1	Elbow, 90° 1/2 Street Brass	04730-206-08-00
22	2	Adapter, Male	04370-401-03-01
23	1	Tube, Copper 1/2" x 19.5" Long	05700-011-59-84
24	1	VAC Breaker 1/2 Brass Bon.	04820-003-06-13
	1	VAC Breaker Repair Kit (Not Shown)	4820-001-60-56
25	1	Fitting, 1/4 Brass Nut/Sleeve	05310-924-02-05

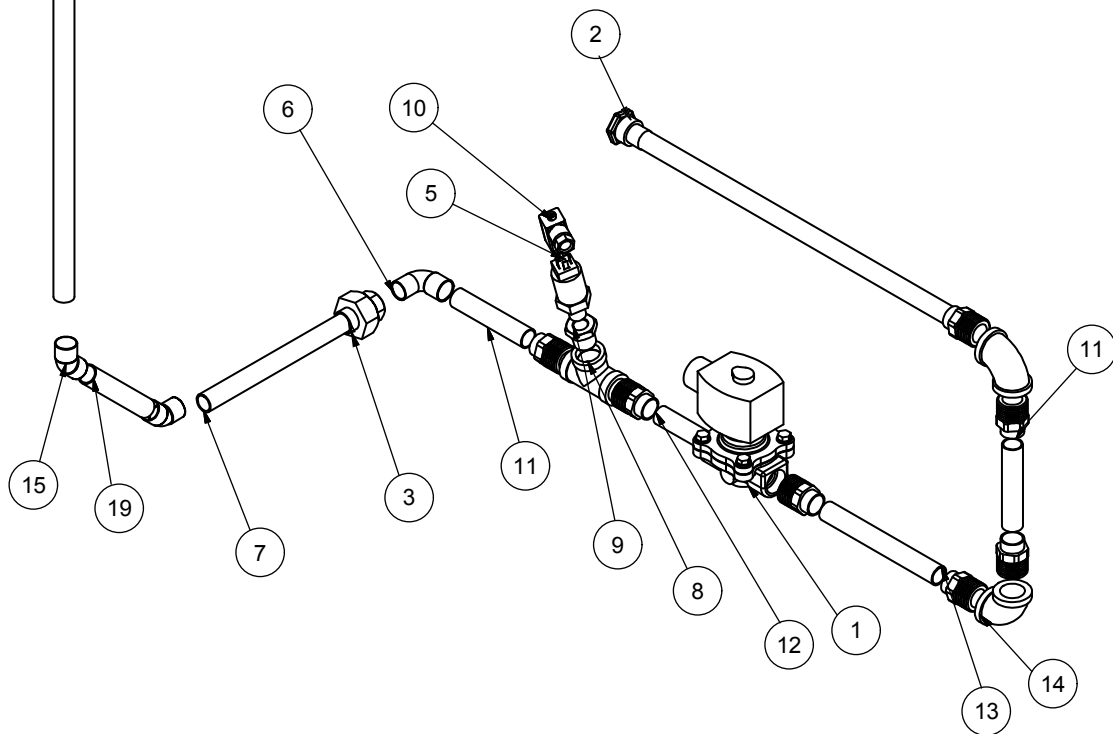
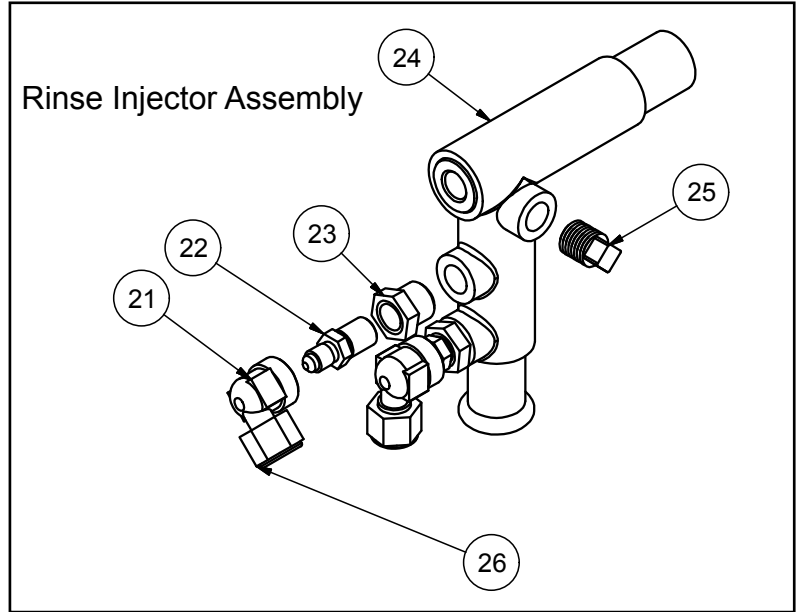
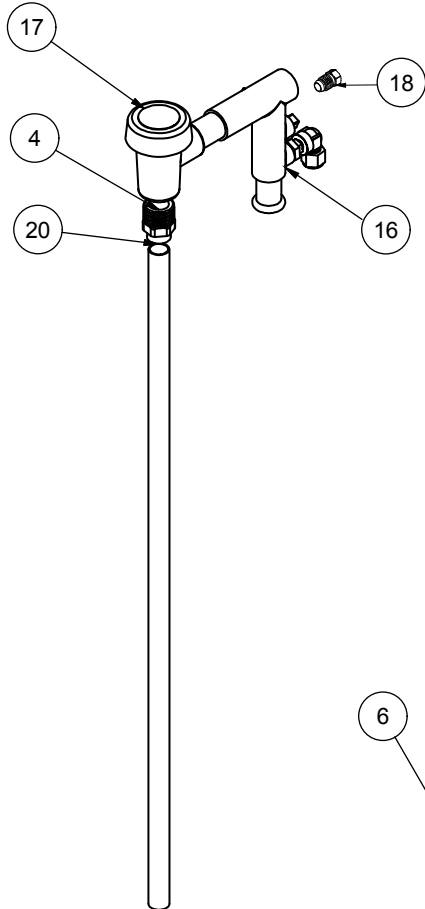

ITEM	QTY	DESCRIPTION	PART NUMBER
1	1	Valve, 1/2" 115V	04810-003-71-55
2	1	A-Plumbing, Inc to Reg, AVG HT ES	05700-004-04-44
3	1	Union, 1/2" (C/C) (733CAST)	04730-412-05-01
4	1	Adapter, Male (CU to MSPS)	04730-401-03-01
5	1	Transducer, Pressure 0-50 PSIG	05945-004-17-01
6	1	Elbow, 1/2 S. CU to FTG.	04730-406-31-01
7	1	F-Tube, Copper 1/2" x 7" Long	05700-002-13-81
8	1	Tee, 1/2" Brass	04730-211-27-00
9	1	Reducer, 1/2" x 1/4" Brass	04730-003-62-16
10	1	Hardness, PTD Connection	05999-004-21-58
11	1	F-Tubing, Copper 1/2 x 3	05700-001-05-21
12	1	F-Tube,AC1/2 x 7 Copper	05700-001-04-66
13	1	F-Copper Pipe, 4.75" Long	04820-004-09-37
14	1	Elbow, 1/2 NPT90 Brass	05700-002-91-02
15	1	Elbow, 1/2 45 Deg Copper (F) X (F)	04730-001-67-77
16	1	A-Injector, icoming AVG HT ES	05700-004-08-29
17	1	VAC Breaker 1/2 Brass Bon.	04820-003-06-13
	1	VAC Breaker Repair Kit (Not Shown)	4820-001-60-56
18	1	Fitting, 1/4 61HD-4 Brass Nut/Sleeve	05310-924-02-08
19	1	F-Tube, 1/2" Copper X 3.5" Long	05700-003-22-22
20	1	F-Tube, 1/2" X 24" Copper	05700-004-08-23

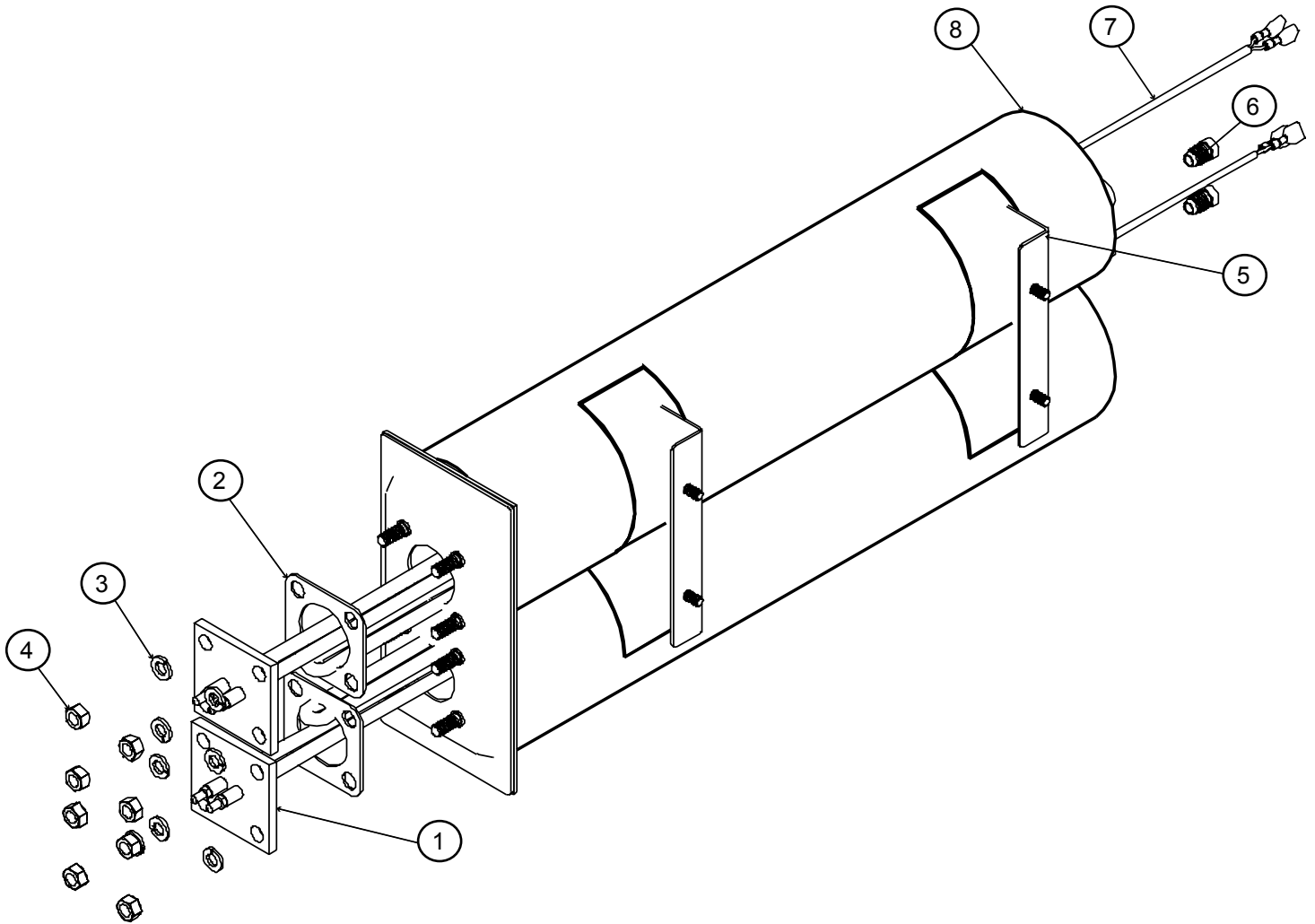

ITEM	QTY	DESCRIPTION	PART NUMBER
1	2	Booster Heater, 2kW	04540-003-98-38
	1	** 480V Unit Only	04540-004-13-30
2	2	Heater Gasket	05330-100-01-10
	1	** 480V Heater Gasket	05330-011-47-79
3	8	Lockwasher, Split 5/16" S/S	N/A
4	8	Nut, Hex 5/16-18 S/S	N/A
5	1	W-Booster	05700-004-04-16
	1	** 480V Booster	05700-004-13-25
6	2	Fitting, 1/4", 61HD-4 Brass Nut/Sleeve	05310-924-02-05
7	2	Probe, Temperature	06680-002-16-80
8	2	Insulation, Booster Tank Wrap	05700-004-09-57

\*\* Models with 480V Control Box

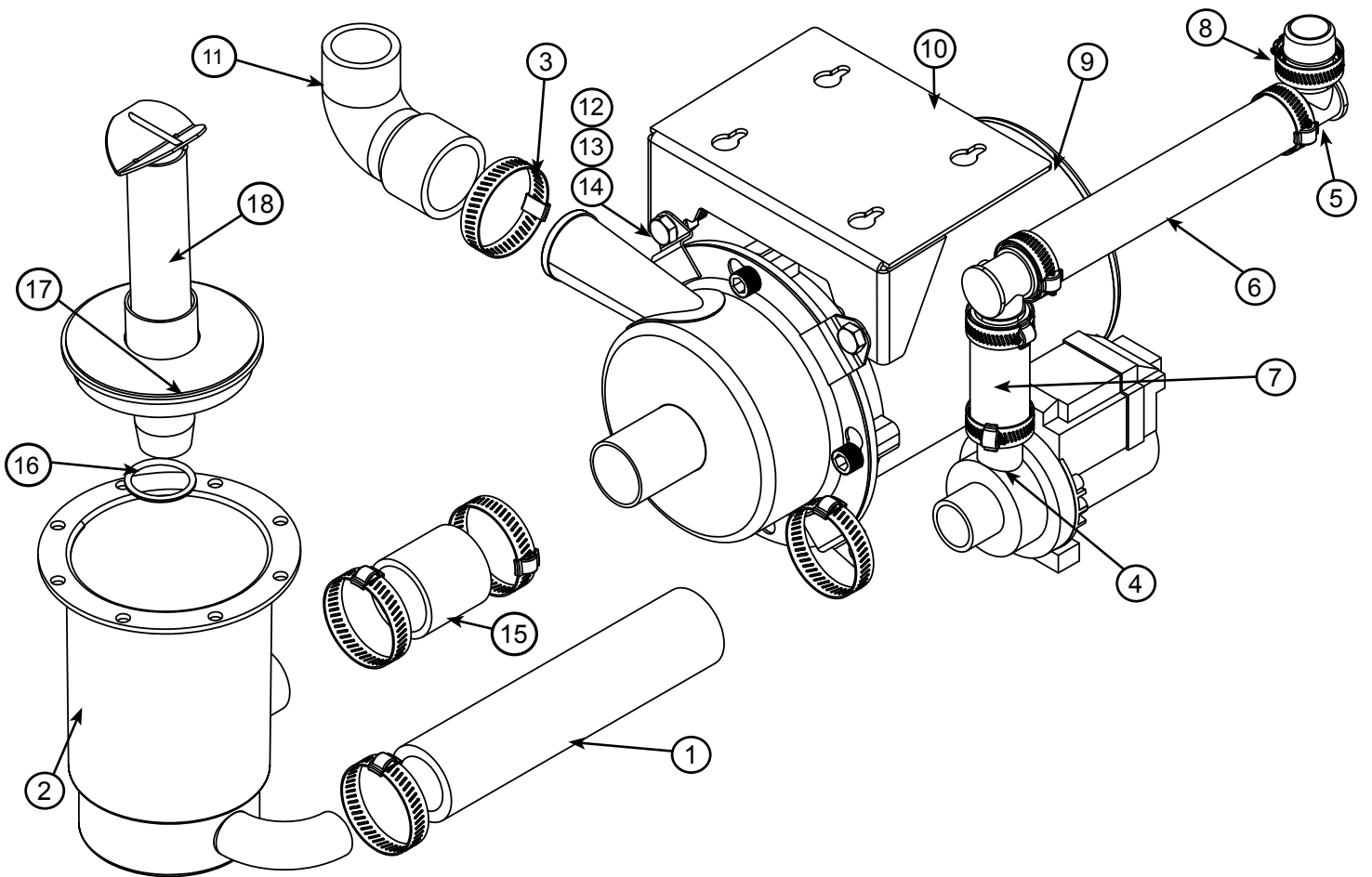

ITEM	QTY	DESCRIPTION	PART NUMBER
1	1	Hose 1-1/4 x 8	05700-004-08-21
2	1	Sump	05700-004-02-94
3	2	Clamp, Reg. Range 1-1/16 to 2 HS24	04730-719-18-00
4	1	Pump, Drain	04730-003-91-41
5	2	Elbow, Hose Barb Drain	04720-004-20-12
6	1	Hose, Drain 8"	04720-111-39-73
7	1	Hose, Drain 3"	04720-111-39-73
8	5	Clamp, Reg. Range 13/16- 1 1/2 #16	04730-719-06-09
9	1	Wash Pump	06105-002-16-29
	1	** 480V Wash Pump	06105-004-07-54
10	1	Brace, Motor Mount	05700-004-01-64
11	1	Elbow, Pump to Wash Manifold	04720-004-02-73
12	2	Lockwasher, 3/8	05311-276-01-00
13	2	Nut, Hex 3/8-16 x 1 Long	05310-276-01-00
14	2	Bolt, Hex 3/8-16 X1 Long	05305-276-03-00
15	1	Bottom Wash Dishcharge Hose	05700-001-22-92
16	1	O-Ring, Viton	05330-400-05-00
17	1	Sump Strainer	05700-004-03-73
18	1	Stand Pipe	05700-004-04-40

\*\* Models with 480V Control Box

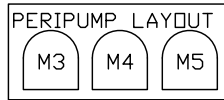
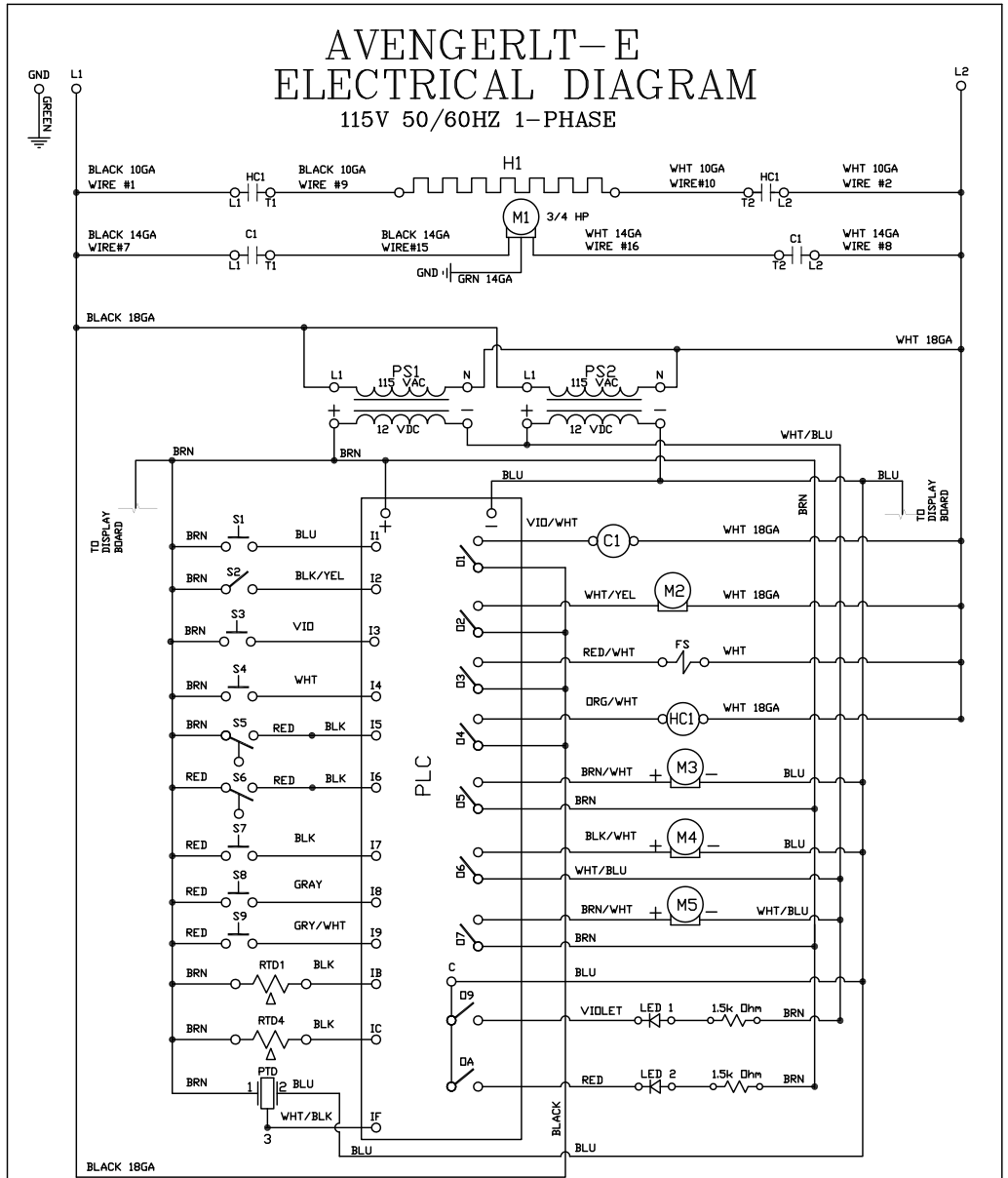

LEGEND			
C1	WASH MOTOR CONTACTOR	M4	RINSE AID MOTOR
FS	FILL SOLENOID	M5	SANITIZER MOTOR
GND	GROUND	PS1	POWER SUPPLY
H1	WASH HEATER	PS2	POWER SUPPLY
HC1	WASH HEATER CONTACTOR	PTD	PRESSURE TRANSDUCER
LED 1	FLUSH INDICATOR LED	RTD 1	WASH REGULATION THERMOSTAT
LED 2	DELIME INDICATOR LED	RTD 2	TEMPERATURE GAUGE
M1	WASH MOTOR	S1	POWER SWITCH
M2	DRAIN MOTOR	S2	DOOR SAFETY SWITCH
M3	DETERGENT MOTOR	S3	CYCLE SWITCH
S4	DELIME SWITCH	S5	HORIZONTAL FLOAT
S6	VERTICAL FLOAT	S7	DETERGENT PRIME SWITCH
S8	RINSE AID PRIME SWITCH	S9	SANITIZER PRIME SWITCH

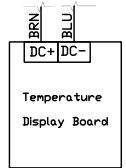



## AVENGERHT-E ELECTRICAL DIAGRAM 208/230 50/60HZ 1-PHASE

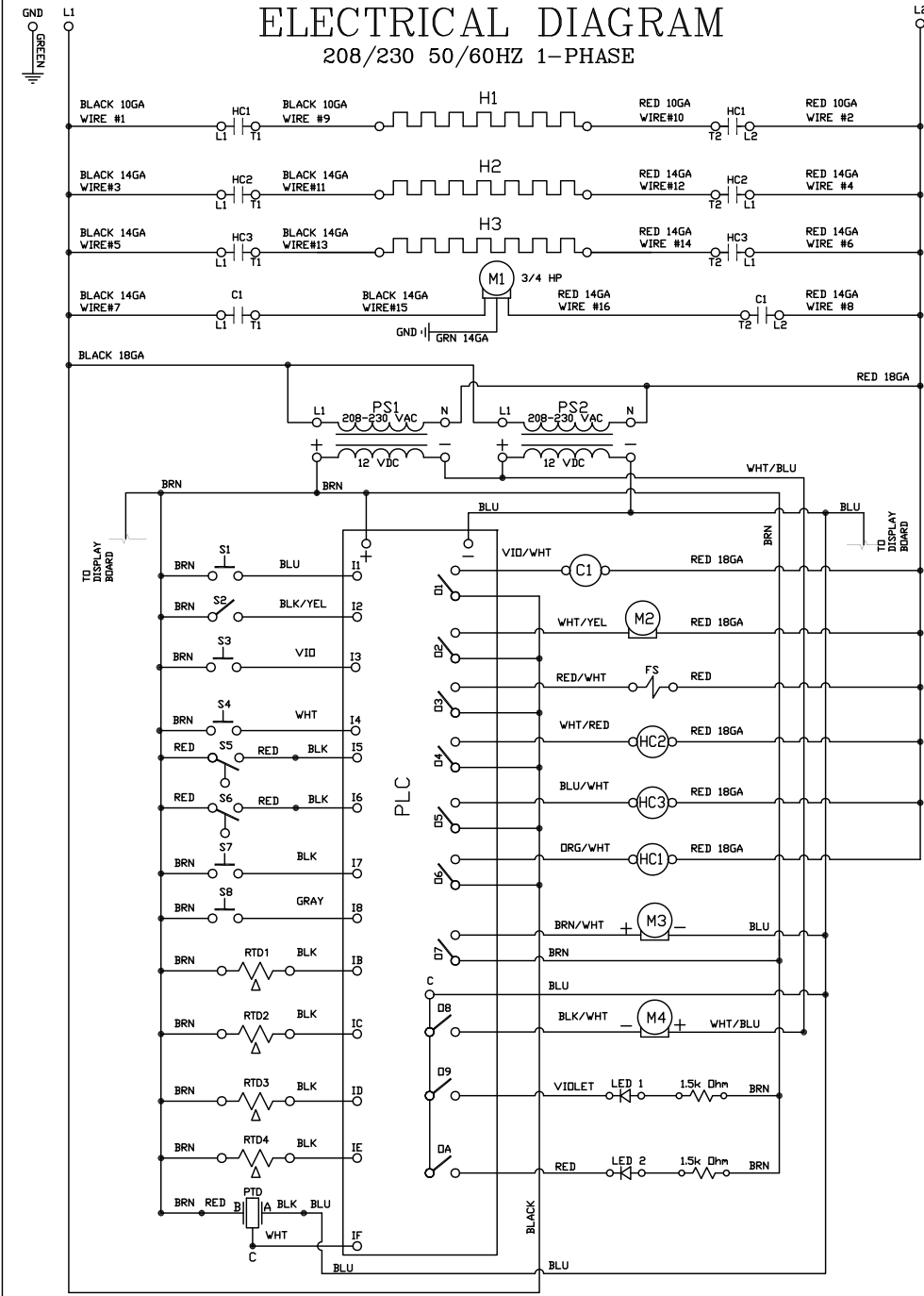

### LEGEND

GND	GROUND	S1	POWER SWITCH	PS2	POWER SUPPLY	C1	WASH MOTOR CONTACTOR
H1	WASH HEATER	S2	DOOR SAFETY SWITCH	RTD1	WASH REGULATING THERMOSTAT	LED 1	FLUSH INDICATOR LED
H2	RINSE HEATER TOP	S3	CYCLE SWITCH	RTD2	TOP RINSE TANK THERMOSTAT	LED 2	DELIME INDICATOR LED
H3	RINSE HEATER BOTTOM	S4	DELIME SWITCH	RTD3	LOWER RINSE TANK THERMOSTAT		
M1	WASH MOTOR	S5	HORIZONTAL FLOAT SWITCH	RTD4	TEMPERATURE GAUGE		
M2	DRAIN MOTOR	S6	VERTICAL FLOAT SWITCH	FS	RINSE/FILL SOLENOID		
M3	DETERGENT MOTOR	S7	RINSE AID PRIME SWITCH	HC1	WASH HEATER CONTACTOR		
M4	RINSE AID MOTOR	S8	DETERGENT PRIME SWITCH	HC2	TOP RINSE HEATER CONTACTOR		
PTD	PRESSURE TRANSDUCER	PS1	POWER SUPPLY	HC3	LOWER RINSE HEATER CONTACTOR		

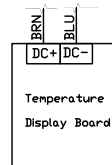

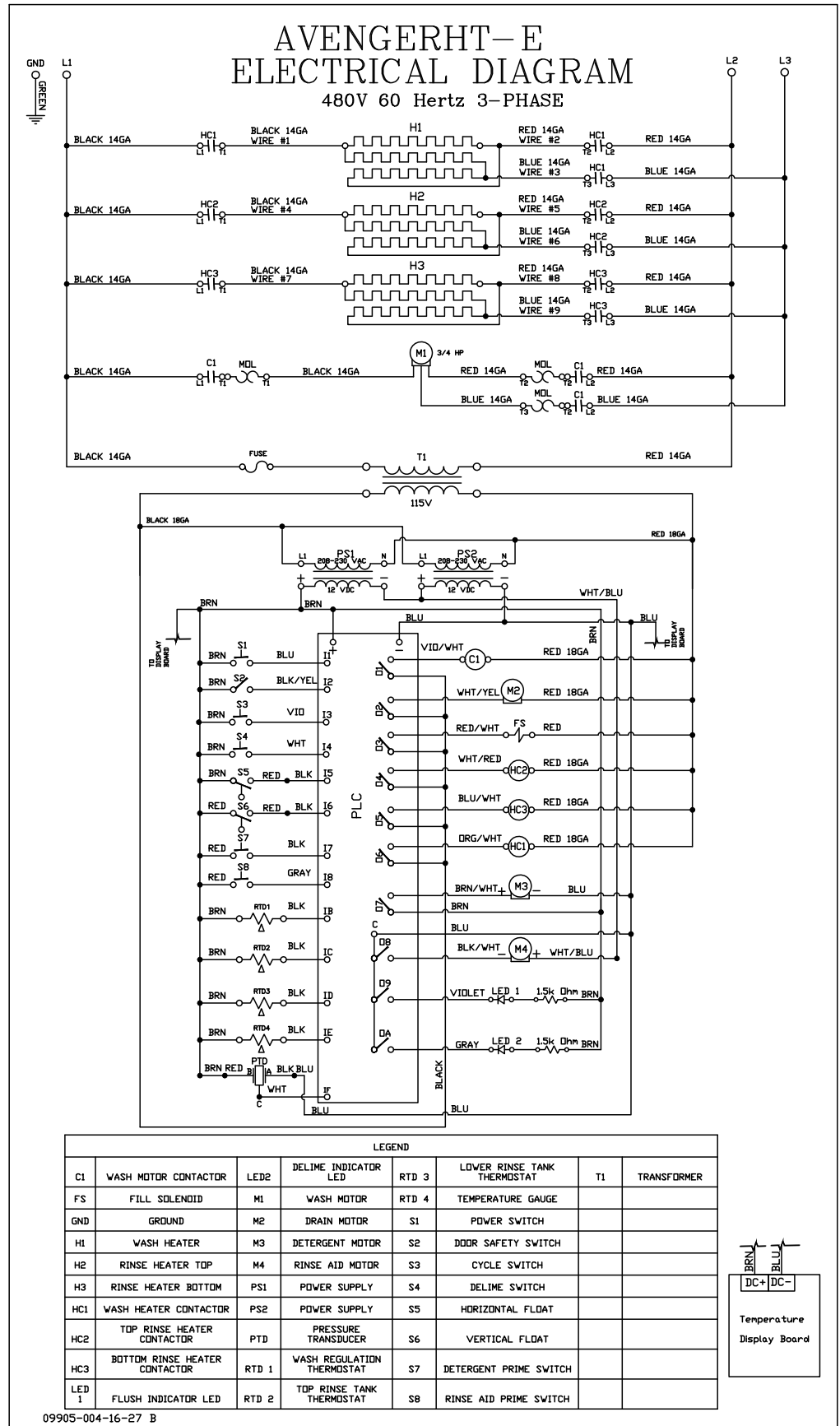



Jackson WWS, Inc. • 6209 N. US Hwy 25E • Gray, KY 40734 USA  
1.888.800.5672 • [www.jacksonwws.com](http://www.jacksonwws.com)