

INSTALLATION, OPERATION & SERVICE MANUAL

FOR JACKSON MODELS:

Delta 5



Delta 5 D



Jackson[®]
Warewashing Systems

MANUFACTURERS WARRANTY

ONE YEAR LIMITED PARTS & LABOR WARRANTY

ALL NEW JACKSON DISHWASHERS ARE WARRANTED TO THE ORIGINAL PURCHASER TO BE FREE FROM DEFECTS IN MATERIAL OR WORKMANSHIP, UNDER NORMAL USE AND OPERATION FOR A PERIOD OF (1) ONE YEAR FROM DATE OF PURCHASE, BUT IN NO EVENT TO EXCEED (18) EIGHTEEN MONTHS FROM DATE OF SHIPMENT FROM THE FACTORY.

Jackson WWS agrees under this warranty to repair or replace, at its discretion, any original part which fails under normal use due to faulty material or workmanship during the warranty period, providing the equipment has been unaltered, and has been properly installed, maintained and operated in accordance with applicable factory instruction manual furnished with the machine and failure is reported to the authorized service agency within the warranty period. This includes the use of factory specified genuine replacement parts, purchased directly from a Jackson authorized parts distributor or service agency. Use of generic replacement parts may create a hazard and void warranty certification.

The labor to repair or replace such failed part will be paid by Jackson WWS, within the continental United States, Hawaii and Canada, during the warranty period provided a Jackson WWS authorized service agency, or those having prior authorization from the factory, performs the service. Any repair work by persons other than Jackson WWS authorized service agency is the sole responsibility of the customer. Labor coverage is limited to regular hourly rates; overtime premiums and emergency service charges will not be paid by Jackson WWS.

Accessory components not installed by the factory carry a (1) one year parts warranty only. Accessory components such as table limit switches, pressure regulators, pre-rinse units, etc. that are shipped with the unit and installed at the site are included. Labor to repair or replace these components is not covered by Jackson WWS.

This warranty is void if failure is a direct result from shipping, handling, fire, water, accident, misuse, acts of God, attempted repair by authorized persons, improper installation, if serial number has been removed or altered, or if unit is used for purpose other than originally intended.

TRAVEL LIMITATIONS

Jackson WWS limits warranty travel time to (2) two hours and mileage to (100) one hundred miles. Jackson WWS will not pay for travel time and mileage that exceeds this, or any fees such as those for air or boat travel without prior authorization.

WARRANTY REGISTRATION

To register your product go to www.jacksonwws.com or call 1-888-800-5672. Failure to register your product will void the warranty.

REPLACEMENT PARTS WARRANTY

Jackson replacement parts are warranted for a period of 90 days from date of installation or 180 days from the date of shipment from the factory, whichever occurs first.

PRODUCT CHANGES AND UPDATES

Jackson WWS reserves the right to make changes in design and specification of any equipment as engineering or necessity requires.

THIS IS THE ENTIRE AND ONLY WARRANTY OF JACKSON WWS. JACKSON'S LIABILITY ON ANY CLAIM OF ANY KIND, INCLUDING NEGLIGENCE, WITH RESPECT TO THE GOODS OR SERVICES COVERED HEREUNDER, SHALL IN NO CASE EXCEED THE PRICE OF THE GOODS OR SERVICES OR PART THEREOF WHICH GIVES RISE TO THE CLAIM.

THERE ARE NO WARRANTIES, EXPRESSED OR IMPLIED, INCLUDING FOR FITNESS OR MERCHANTABILITY, THAT ARE NOT SET FORTH HEREIN, OR THAT EXTEND BEYOND THE DURATION HEREOF. UNDER NO CIRCUMSTANCES WILL JACKSON WWS BE LIABLE FOR ANY LOSS OR DAMAGE, DIRECT OR CONSEQUENTIAL, OR FOR THE DAMAGES IN THE NATURE OF PENALTIES, ARISING OUT OF THE USE OR INABILITY TO USE ANY OF ITS PRODUCTS.

ITEMS NOT COVERED

THIS WARRANTY DOES NOT COVER CLEANING OR DELIMING OF THE UNIT OR ANY COMPONENT SUCH AS, BUT NOT LIMITED TO, WASH ARMS, RINSE ARMS OR STRAINERS AT ANYTIME. NOR DOES IT COVER ADJUSTMENTS SUCH AS, BUT NOT LIMITED TO TIMER CAMS, THERMOSTATS OR DOORS, BEYOND 30 DAYS FROM THE DATE OF INSTALLATION. IN ADDITION, THE WARRANTY WILL ONLY COVER REPLACEMENT WEAR ITEMS SUCH AS CURTAINS, DRAIN BALLS, DOOR GUIDES OR GASKETS DURING THE FIRST 30 DAYS AFTER INSTALLATION. ALSO, NOT COVERED ARE CONDITIONS CAUSED BY THE USE OF INCORRECT (NON-COM-MERCIAL) GRADE DETERGENTS, INCORRECT WATER TEMPERATURE OR PRESSURE, OR HARD WATER CONDITIONS.

REVISION/ PAGE	REVISION DATE	MADE BY	APPLICABLE ECN	DETAILS
A	05-25-2007	MAW	N/A	Release to production.
24	10-04-2007	MAW	7934	Changed cover on power junction box.
10	05-20-2009	ARL	QOF 339	Updated programming page diagram.
B	04-26-2012	RLC	QOF 386	Updated location of door switch on schematic.
C	04-27-2012	RLC	QOF 386	Added EnergyStar logo.
D	03-08-13	RLC	QOF NDB-219	Updated company logo
E	01-23-14	MHH	QOF NDB-238	Added wiring change schematics. Removed "Stop" page. Updated warranty information.
F	03-12-14	MHH	ECN 8293	Removed page on programming chemical feeder pumps. Updated drawings for control box assembly, motor & pump assembly and incoming plumbing assembly. Added schematics and harness connections.



Delta 5

Delta 5 - Low temperature, chemically sanitizing, with a booster tank.
Detergent, rinse aid & sanitizer chemical feeder pumps

Delta 5 D - Dual door. Low temperature, chemically sanitizing, with a booster tank.
Detergent, rinse aid & sanitizer chemical feeder pumps

Model: _____

Serial No.: _____

Installation Date: _____

Service Rep. Name: _____

Phone No.: _____

Jackson WWS, INC. provides technical support for all of the dishmachines detailed in this manual. Jackson strongly recommends that users refer to this manual before calling technical support staff. Users should have this manual on hand when calling technical support. Technical support is available from 8:00 a.m. to 5:00 p.m. (EST), Monday through Friday, for service personnel only. Technical support is not available on holidays. Call toll free at 1-888-800-5672.

TABLE OF CONTENTS

<u>SECTION</u>	<u>DESCRIPTION</u>	<u>PAGE</u>
I.	SPECIFICATION INFORMATION	
	Specifications	2
	Dimensions	3
II.	INSTALLATION/OPERATION INSTRUCTIONS	
	Installation Instructions	5
	Electrical Installation Instructions	6
	Operation Instructions	7
	Chemical Dispensing Equipment	9
	Detergent Control	10
III.	PREVENTATIVE MAINTENANCE	12
IV.	TROUBLESHOOTING SECTION	
	Common Problems	14
V.	PARTS SECTION	
	Chemical Feeder Pump Assembly	17
	Solenoid Valve Repair Parts	18
	Control Box Assembly	19
	Peripump Box Assembly	22
	Electrical Connection Box Assembly	23
	Frame Assembly	24
	Hood Assembly	25
	Switch Panel Assembly	26
	Tub Assembly	27
	Frame & Motor Assembly	29
	Pump and Motor Assembly	31
	Booster Tank Assembly	32
	Incoming Plumbing Assembly	33
	Door Assembly	34
	Front Panel Assembly	35
VI.	ELECTRICAL SCHEMATICS	
	Delta 5 (prior to serial # 14A288762)	37
	Delta 5 (after serial # 14A288762)	38
	Delta 5 115 V, 50/60 Hertz, Single Phase	39
	Delta 5 Harness Connections	40
VII.	JACKSON MAINTENANCE & REPAIR CENTERS	42

SECTION 1: SPECIFICATION INFORMATION

SECTION 1: SPECIFICATION INFORMATION

SPECIFICATIONS

OPERATING CAPACITY (NSF RATED):

RACKS PER HOUR	29
DISHES PER HOUR	725
GLASSES PER HOUR	725

ELECTRICAL REQUIREMENTS:

WASH PUMP MOTOR HP	3/4
--------------------	-----

OPERATING CYCLES (SECONDS):

NORMAL CYCLE:

WASH TIME	45
RINSE TIME	25
TOTAL CYCLE TIME	90

<u>VOLTS</u>	<u>PH</u>	<u>HZ</u>	<u>RINSE HEATER RATINGS</u>	<u>TOTAL AMPS</u>	<u>TYPICAL ELECTRICAL CIRCUIT</u>
115	1	60	2KW@110V	*16 A	20 AMP

* This dishmachine is designed so that the wash motor is never running when the wash heater is on. Service load is based upon the higher of the two amperages.

WASH TANK CAPACITY (GALLONS):	1.2
-------------------------------	-----

WASH PUMP CAPACITY (GPM):	61
---------------------------	----

NOTE: Typical Electrical Circuit is based upon (1) 125% of the full amperage load of the machine and (2) typical fixed-trip circuit breaker sizes as listed in the NEC 2002 Edition. Local codes may require more stringent protection than what is displayed here. Always verify with an electrical service contractor that the circuit protection is adequate and meets all applicable national and local codes. These numbers are provided in this manual simply for reference and may change without notice at any given time.

OPERATING TEMPERATURES:

WASH (MINIMUM)	(48.9°C) 120°F
WASH (RECOMMENDED)	(60.0°C) 140°F
RINSE (MINIMUM)	(48.9°C) 120°F
RINSE (RECOMMENDED)	(60.0°C) 140°F

FRAME DIMENSIONS:

WATER REQUIREMENTS:

WATER LINE SIZE NPT	1/2"
DRAIN LINE SIZE NPT	2"
FLOW PRESSURE	20 ± 5 PSI

WIDTH	(622.3mm)	24 1/2"
DEPTH	(641.35mm)	25 1/4"
DEPTH, WITH FRONT DOOR OPEN	(933.45mm)	36 3/4"
HEIGHT	(990.6mm)	39"
MAXIMUM WASH CHAMBER CLEARANCE	(292.1mm)	11 1/2"

MINIMUM CHLORINE REQUIRED (PPM):	50
----------------------------------	----

FRAME DIMENSION (DOUBLE DOOR):

WIDTH	(622.3MM)	24 1/2"
DEPTH	(714.375MM)	28 1/8"
DEPTH, WITH DOOR OPEN	(1311.275MM)	51 5/8"
HEIGHT	(990.6MM)	39"
CHAMBER CLEARANCE	(292.1MM)	11 1/2"

NOTE: Always refer to the machine data plate for specific electrical and water requirements. The material provided on this page is for reference only and may be subject to change without notice.

SECTION 1: SPECIFICATION INFORMATION

DIMENSIONS

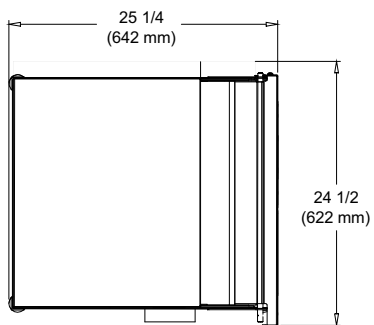

- A - Incoming Water Connection
- B - Drain Connection - 2" IPS
- C - Electrical Connection Point

NOTE: All vertical dimensions are at lowest point due to adjustable bullet feet and may be raised an additional 2 3/4".

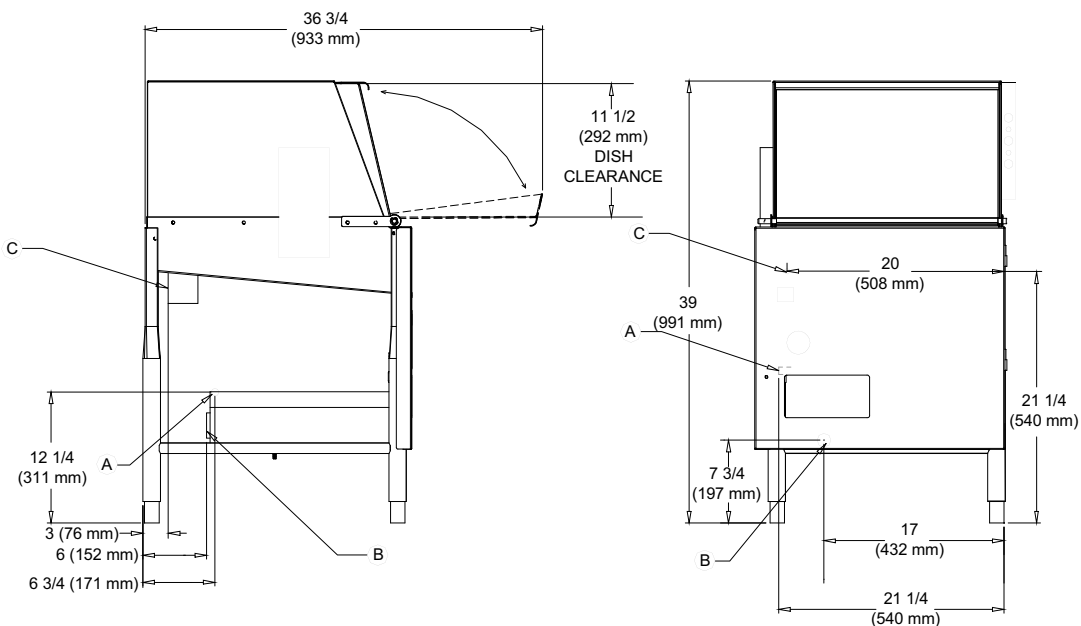

DOUBLE DOOR MODEL
LEFT SIDE OF UNIT

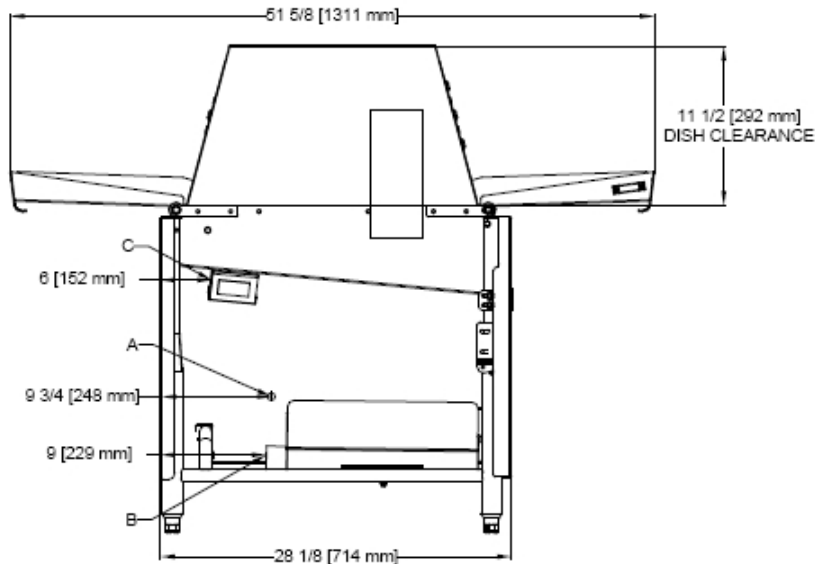

SECTION 2: INSTALLATION & OPERATION INSTRUCTIONS

SECTION 2: INSTALLATION & OPERATION INSTRUCTIONS

INSTALLATION INSTRUCTIONS

VISUAL INSPECTION: Before installing unit check container and machine for damage. A damaged container may be an indication of damage to the machine. If there is any type of damage to both container and unit, do not throw away the container. The dishmachine has been inspected at the factory prior to shipping and is expected to arrive in new, undamaged condition. However, rough handling by carriers or others may result in damage to the unit while it is in transit. If such a situation occurs, do not return the unit to the manufacturer. Instead, contact the carrier and ask them to send a representative to the site to inspect the damage, and request that an inspection report be completed. Contact the carrier within 48 hours of receiving the machine (to report possible freight damage) and the dealer from whom the unit was purchased.

UNPACKING THE DISHMACHINE: Remove the machine from the container and inspect it for any missing parts. If a part is missing, contact manufacturer immediately.

LEVEL THE DISHMACHINE: The dishmachine is designed to operate while level. This is important to prevent any damage to the machine during operation and to ensure the best results possible. The unit is equipped with adjustable bullet feet which can be turned using a pair of pliers. Verify the unit is level from front to back and side to side before making any electrical or plumbing connections.

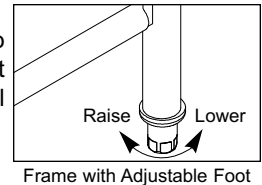

PLUMBING THE DISHMACHINE: All plumbing connections must be made to adhere to local, state, territorial and national codes. The installing plumber is responsible for ensuring the incoming water lines are flushed of debris prior to connecting to the machine. Note that chips and materials from cutting processes can become lodged in the solenoid valves and prevent them from opening or closing. Any valves that are found to be fouled or defective because of foreign matter left in the water line, and any subsequent water damage, are not the responsibility of the manufacturer.

A water hardness test should be performed to determine if the HTS-11 (scale prevention & corrosion control) needs to be installed. If water hardness is higher than 5 GPG, the HTS-11 will need to be installed. Please contact manufacturer to purchase the HTS-11.

CONNECTING THE DRAIN LINE: This dishmachine drain requires a minimum 2" NPT piping that is pitched at least 1/4" per foot. There must also be an air gap between the machine drain line and the floor sink or drain. If a grease trap is required by code, it should have a flow capacity of 5 gallons per minute.

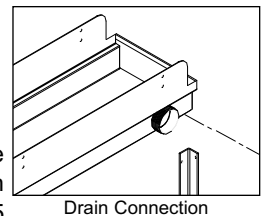

WATER SUPPLY CONNECTION: Install the water supply line (1/2" NPT minimum) to the dishmachine line y-strainer using copper pipe. It is recommended that a water shut-off valve be installed between the main supply and the machine to allow for service. The water supply line must be capable of 20 ± 5 PSI "flow" pressure at the recommended temperature as indicated on the data plate.

PRESSURE REGULATOR: In areas where the water pressure fluctuates or is greater than the recommended pressure, it is suggested that a water pressure regulator be installed. This dishmachine does not come with a water pressure regulator as standard equipment.

SHOCK ABSORBER: It is recommended that a shock absorber (not supplied) be installed in the incoming water line. This prevents water hammer (hydraulic shock)—induced by the solenoid valve as it operates—from causing damage to the equipment.

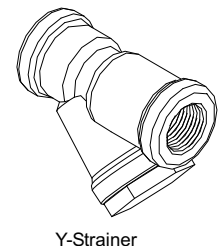

PLUMBING CHECK: Slowly turn on the water supply to the machine after connecting the incoming fill line and drain line. Check for leaks and repair as required. Leaks must be repaired prior to operating the machine.

SECTION 2: INSTALLATION & OPERATION INSTRUCTIONS

ELECTRICAL INSTALLATION INSTRUCTIONS

ELECTRICAL POWER CONNECTION: DISCONNECT ELECTRICAL POWER SUPPLIES & TAG OUT IN ACCORDANCE WITH APPROPRIATE PROCEDURES & CODES AT THE DISCONNECT SWITCH TO INDICATE THE CIRCUIT IS BEING SERVICED.

Electrical and grounding conductors must comply with the applicable portions of the National Electric Code ANSI/NFPA 70 (latest edition) and/or other electrical codes.

Refer to the machine's data plate for machine operating requirements, machine voltage, total amperage & serial number.

Remove the connection box lid to install the incoming power lines. Install 1/2" conduit into the pre-punched holes in the back of the connection box. Route the power wires and connect to the power block and grounding lug. Install the service wires (L1 and N) to the appropriate terminals as they are marked on the terminal block. Install the grounding wire into the lug provided. Wires should be firmly secured in place.

It is recommended that "De-Ox" or another similar anti-oxidation agent be used on all voltage connections.

VOLTAGE CHECK: Ensure that the machine is off and apply power to the machine. Check the incoming power at the terminal block and ensure it corresponds to the voltage on the machine data plate. Do not run the dishmachine if the voltage is too high or too low. Shut off the service breaker and mark it as being for the dishmachine. Advise all personnel of the location of the service breaker. Replace all covers and tighten the screws.

NOTE: Always refer to the machine data plate for specific electrical and water requirements. The material provided on this page is for reference only and may be subject to change without notice.

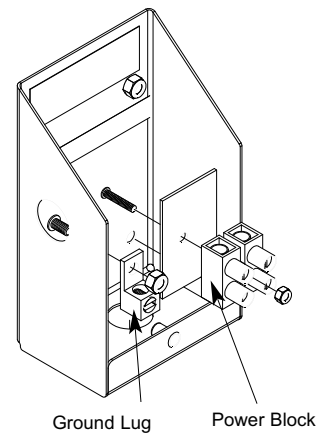

SECTION 2: INSTALLATION & OPERATION INSTRUCTIONS

OPERATION INSTRUCTIONS

OPERATIONAL START-UP AND CHECK: Before proceeding with the start-up, verify the following:

1. Open the door and verify that the sump strainer is correctly installed in the sump.
2. Verify that the drain stopper is in position.
3. Check that the plugs are securely screwed into the ends of the wash arm.
4. Check that the wash arm is securely screwed into the stationary base and that it rotates freely.
5. Check the levels in all chemical containers and replace if necessary.

INITIAL START-UP PROCEDURE:

1. Turn on dishmachine:
 - a) Turn on the incoming power to the machine at the circuit disconnect box.
 - b) Turn on the dishmachine by pressing the ON/OFF button. The red light will come on.
 - c) Check voltage at incoming terminals L1& L2. The voltage measured at these points should match data plate voltage.
 - d) If voltages are in required range, close the control box cover.
2. Fill the rinse booster heater with water:
 - a) Before the heater element can be energized, the rinse booster heater must be initially filled with water. Damage to the heater element will occur if the element is not submerged in water. To initially fill the booster heater with water:
 - i) Press and hold the FILL button to turn on the incoming water solenoid valve. Continue holding the button until water is heard entering the wash chamber through the airgap, then release the button. The rinse booster heater is now filled with water.
 - ii) Turn off the unit by pressing the on/off switch.
3. Enable heater element:
 - a) For the initial start-up only, the heater element must be enabled. The machine is shipped from the factory with the heater element disabled. This is done to ensure that the heater element is not damaged by energizing the element without the element being submerged in water. To enable the heater element:
 - i) Remove the booster heater cover panel.
 - ii) Connect the tagged white/blue wires.
 - iii) Replace heater cover.
 - iv) Press the on/off switch, heaters will energize to maintain booster heater temperature.

Note: Water must be in the sump while the machine is running to avoid running the pump dry and causing damage to the pump seal.

4. Adjust dishmachine fill level:
 - a) If the water level is not between the lines on the drain standpipe, it will require adjustment. Check to ensure that the recommended water pressure is being supplied to the machine (20 ±5 PSI is required). If the water pressure is correct, the electronic timer will need adjustment. Use the following steps to adjust the fill time.
 - i) Open control box cover.
 - ii) Adjust fill time as per instructions found in this section.
 - iii) Open and close the door to run a cycle, then check the water level. Adjust as necessary then close the control box cover.

NOTE: The machine must run a complete cycle to drain and fill. If the machine is not allowed to drain, the water will build up inside the tub. After the initial fill, the rinse water for the current cycle will become the wash water for the next cycle.

The dishmachine is now ready to proceed with dishwashing.

SECTION 2: INSTALLATION & OPERATION INSTRUCTIONS

OPERATION INSTRUCTIONS

WARNING: Certain materials, including silver, silver plate, aluminum and pewter, are attacked by sodium hypochlorite sanitizers (bleach).

PREPARING DISHES: Proper preparation of ware is essential for the smooth and efficient operation of the dishmachine, resulting in fewer rewashes and using less detergent.

The following steps should be followed to ensure good results:

1. Remove all scraps and soil into a garbage can.
2. Separate and pre-soak silverware.
3. Separate and pre-soak the egg and casserole dishes.
4. Scrape all ware with a brush or spatula.
5. Flush cups, bowls and glasses with running water.
6. Prewash dishware by soaking or spraying with a pre-rinse hose.
7. Place dishes and cups in dish rack. Cups should be upside down so they don't hold water.
8. Place glasses and flatware in their respective racks. Scatter flatware loosely in rack. Glasses should be placed upside down in a properly sized rack. For optimal results, flatware should be washed twice, the first being horizontal, the second in a special rack to hold flatware vertical.

DAILY MACHINE PREPARATION: Before proceeding with start-up, verify the following:

1. Open door and verify that the sump strainer is in place in the sump.
2. Verify that the drain stopper is in position.
3. Check that the plugs are securely screwed into the ends of all wash arms.
4. Check that the wash arms are securely screwed into the stationary bases and rotate freely.
5. Check levels in all chemical containers and replace if empty.
6. For initial fill, close doors and depress the "FILL" switch to the "FILL" position.

WASHING A RACK OF WARE:

1. Open doors, place a full rack into the machine, and close doors. Push the start switch and hold until unit starts (about 2 seconds).
2. After cycle is completed open doors and remove rack.
3. Repeat steps A and B.

SHUT DOWN AND CLEANING:

1. At the end of mealtime, move the "ON/OFF" switch to the "OFF" position.
2. Open doors and manually remove drain stopper to drain the unit.
3. Remove and clean upper and lower wash arms.
4. Remove and clean the sump strainer.

SECTION 2: INSTALLATION & OPERATION INSTRUCTIONS

CHEMICAL DISPENSING EQUIPMENT



WARNING: CHLORINE-BASED SANITIZERS CAN BE DETRIMENTAL TO THE MACHINE IF THE CHEMICAL SOLUTION IS TOO STRONG. SEE A CHEMICAL PROFESSIONAL TO ENSURE THE DISPENSER IS SET UP CORRECTLY.

This equipment is not recommend for use with deionized water or other aggressive fluids. Use of deionized water or other aggressive fluids will result in corrosion and failure of materials and components and will void the manufacturer's warranty.

TO PREPARE CHEMICAL FEEDER PUMPS FOR OPERATION: The Delta 5 dismachines are supplied with detergent, rinse additive and sanitizer dispensing chemical feeder pumps. Locate the open ends of the chemical tubes with the tube stiffeners and place each one in the appropriate container.

Red Tubing = Detergent

Blue Tubing = Rinse Aid

White Tubing = Sanitizer

PRIMING CHEMICAL FEEDER PUMPS: Chemical feeder pumps need priming when the machine is first installed or if for some reason the chemical lines have been removed and air is allowed to enter.



CAUTION: Water must be in the sump and wash tank prior to the dispensing of chemicals. Sanitizer in concentration is caustic and may cause damage without dilution.

1. Verify that the proper chemical tube stiffener inlet is in the proper container.
2. Use the prime switches located on the control panel at the bottom of the unit to prime each pump. The switches are clearly marked as to what chemical feeder pump they are assigned to.
3. To prime the pumps, hold the switch in the momentary position until chemical can be observed entering the sump.
4. Detergent is dispensed as required during the wash cycle by the universal timer. The amount of detergent may need to be increased or decreased depending on water quality and type of detergent.
5. Rinse additive is dispensed as required into the final rinse. The amount of rinse aid may need to be adjusted depending on water hardness and results.
6. Sanitizer (either chlorine or iodine) is dispensed into the final rinse. The amount of sanitizer may need to be adjusted depending on the concentration and type of sanitizer used.
7. Please refer to the next page for instruction on adjusting the chemical feeder pumps on the universal timer.



WARNING: Some of the chemicals used in dishwashing may cause chemical burns if they come in contact with skin. Wear protective gear when handling these chemicals. If any skin comes in contact with these chemicals, immediately follow the instructions provided with the chemicals for treatment.

SECTION 2: INSTALLATION & OPERATION INSTRUCTIONS

DETERGENT CONTROL

DETERGENT CONTROL: Detergent usage and water hardness are two factors that contribute greatly to how efficiently this dishmachine will operate. Using detergent in the proper amount can become a source of substantial savings. A qualified water treatment specialist can relate what is needed for maximum efficiency from the detergent.

1. Hard water greatly affects the performance of the dishmachine, causing the amount of detergent required for washing to increase. If the machine is installed in an area with hard water, the manufacturer recommends the installation of water treatment equipment.
2. Deposited solids from hard water can cause spotting that will not be removed with a drying agent. Treated water will reduce this occurrence.
3. Treated water may not be suitable for use in other areas of operation and it may be necessary to install a water treatment unit for the water going to the dishmachine only. Discuss this option with a qualified water treatment specialist.
4. Dishmachine operators should be properly trained in how much detergent is to be used per cycle. Meet with a water treatment specialist and detergent vendor to discuss a complete training program for operators.
5. Certain dishmachine models require that chemicals be provided for proper operation and sanitization. Some models may require the installation of third-party chemical feeders to introduce those chemicals to the machine. The manufacturer does not recommend or endorse any brand name of chemicals or chemical dispensing equipment. Contact a chemical distributor for questions.
6. Some dishmachines come equipped with integral solid detergent dispensers. These dispensers are designed to accommodate detergents in a certain-sized container. If applicable, relate this to a chemical distributor upon first contacting them.
7. Water temperature is an important factor in ensuring that the dishmachine functions properly, and the machine's data plate details what the minimum temperatures must be for the incoming water supply, the wash tank and the rinse tank. If minimum requirements are not met, there is a possibility that dishes will not be clean or sanitized.
8. Instruct dishmachine operators to observe the required temperatures and to report when they fall below the minimum allowed. A loss of temperature can indicate a larger problem—such as a failed heater—or could indicate that the hot water heater for the operation is not up to capacity and a larger one may need to be installed.

SECTION 3: PREVENTATIVE MAINTENANCE

SECTION 3: PREVENTATIVE MAINTENANCE

PREVENTATIVE MAINTENANCE

PREVENTATIVE MAINTENANCE: The manufacturer of this dishmachine highly recommends that any maintenance and repairs not specifically discussed in this manual should be performed by qualified service personnel only (find qualified service agencies in the back of this manual). Performing maintenance on the dishmachine may void a warranty.

By following the operating and cleaning instructions in this manual, users should get the most efficient results from the dishmachine. As a reminder, here are some steps to ensure that the dishmachine is used properly:

1. Ensure that the water temperatures match those listed on the machine data plate (on the front left of machine).
2. Remove as much soil as possible from dishes before loading into racks.
3. Ensure that all strainers are in place, laying flat in tub and free of soil and debris before operating the machine. To clean strainers, wipe them out with a rag and rinse under a faucet. For stubborn debris, a toothpick can be used to dislodge any obstructions from the perforations. Do not beat strainers on waste cans; once bent they will not work properly.
4. If hard water is present, install an HTS-11 into the water line connecting to the dishmachine (see section "Plumbing the Dishmachine").
5. Ensure that all wash and/or rinse arms are secure in the machine before operating.
6. Ensure that drains are closed/sealed before operating.
7. Do not overfill racks.
8. Ensure that glasses are placed upside down in the rack.
9. Ensure that all chemicals being injected into machine have been verified as being at the correct concentrations.
9. Clean out the machine at the end of every workday as per the instructions in the manual (see section on "Shutdown & Cleaning").
10. Always contact a qualified service agency whenever a serious problem arises.
11. Follow all safety procedures, whether listed in this manual or put forth by local, state or national codes/regulations.

SECTION 4: TROUBLESHOOTING

SECTION 4: TROUBLESHOOTING SECTION

COMMON PROBLEMS



WARNING: Inspection, testing and repair of electrical equipment should be performed only by qualified service personnel. Certain procedures in this section require electrical tests or measurements while power is applied to the machine. Exercise extreme caution at all times. If test points are not easily accessible, disconnect power, attach test equipment and reapply power to test. When replacing electrical parts, disconnect power at source circuit breaker.

Problem: Water overflow from bottom of door.

CAUSE

Clogged drain

Machine not level

Excessive inlet pressure

Detergent foaming

Excessive fill time

SOLUTION

Remove obstruction.

Level machine, or increase height to the front.

Install pressure reducing valve, or adjust if one is present. Ensure flow is 20 ± 5 PSI.

Reduce detergent quantity.

Adjust timer fill time as per Section 2.

Problem: Wash motor doesn't operate on manual wash.

CAUSE

Loose or broken wires

Defective manual wash switch

Defective motor starting relay

SOLUTION

Reconnect or replace wires in motor.

Replace.

Replace.

Problem: Motor operates on manual wash/delime but not on automatic.

CAUSE

Defective circuit in manual wash switch

SOLUTION

Replace switch.

Problem: No water comes through the rinse arms when the "FILL" switch is depressed.

CAUSE

Water not turned on

Defective solenoid valve

SOLUTION

Turn water on.

Replace solenoid valve.

Problem: Little or no water coming through the rinse assemblies.

CAUSE

Limed up rinse heads or piping

Low water pressure

SOLUTION

Delime rinse heads.

Increase pipe size to machine. Adjust pressure regulator.

Continued on next page.

SECTION 4: TROUBLESHOOTING SECTION

COMMON PROBLEMS

Problem: Rinse water runs continuously with breaker turned off.

<u>CAUSE</u>	<u>SOLUTION</u>
Defective plunger in solenoid valve	Replace.
Defective diaphragm in solenoid valve	Replace diaphragm.

Problem: Wash temperature not at required reading on thermometer.

<u>CAUSE</u>	<u>SOLUTION</u>
Check that white/blue wires are connected	See note on page 12.
Defective thermometer	Replace.
Defective thermostat	Adjust or replace thermostat.
Rinse heater defective	Replace heater element.
Defective heater contactor R2	Replace.
Incoming inlet water temperature below required minimum.	Adjust.
Defective heater delay relay (R4)	Replace.

Problem: Rinse water not at required temperature range.

<u>CAUSE</u>	<u>SOLUTION</u>
Check that white/blue wires are connected	See note in installation instructions.
Thermometer is defective	Replace.
Thermostat is defective	Adjust or replace the thermostat.
Incoming rinse water does not meet minimum criteria indicated on machine data plate	Adjust as required.

Problem: No indication of pressure.

<u>CAUSE</u>	<u>SOLUTION</u>
Water turned off	Turn water on.
Pressure gauge defective	Replace pressure gauge.

SECTION 5: PARTS SECTION

SECTION 5: PARTS SECTION
CHEMICAL FEEDER PUMP ASSEMBLY

Squeeze Tube Lubricant

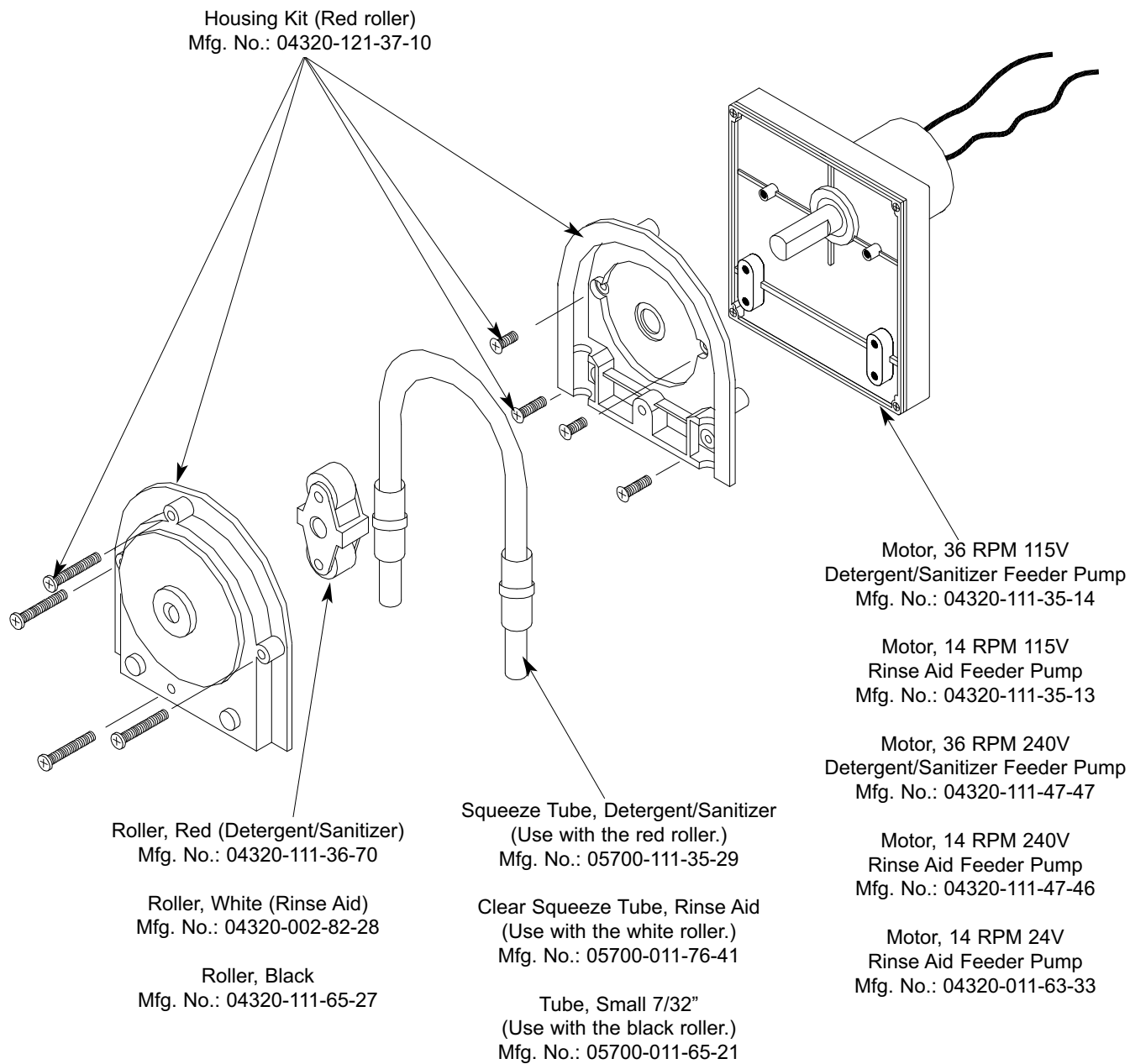

1/4" Sight Tube
3/8" Sight Tube

Mfg. No.: N/A
Mfg. No.: 05700-111-35-33

SECTION 5: PARTS SECTION
SOLENOID VALVE REPAIR PARTS KITS

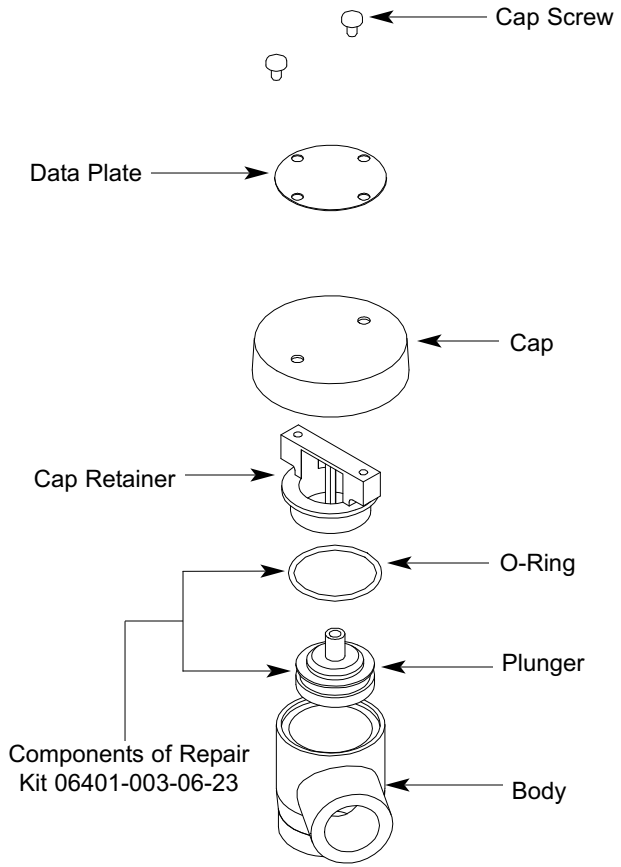
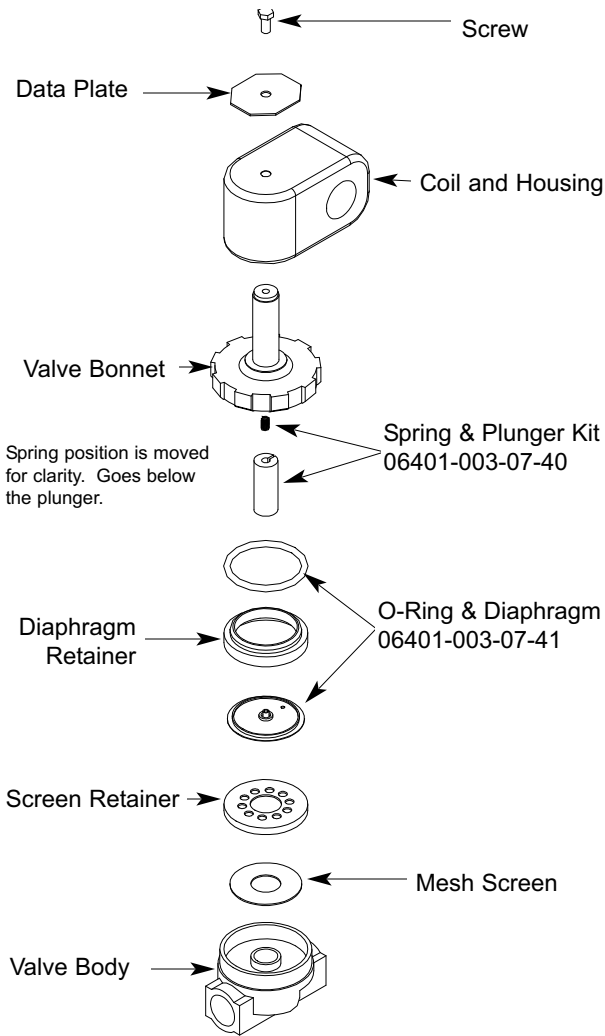

Complete Vacuum Breaker Assembly, 1/2" NPT
 04820-003-06-13

Complete 110 Volt Solenoid Valve Assembly, 1/2"
 04810-100-12-18

Coil & Housing only, 1/2"
 06401-003-07-43

Complete 220 Volt Solenoid Valve Assembly, 1/2"
 04810-100-09-18

Coil & Housing only, 1/2"
 06401-003-07-44

Water Hammer Arrestor Assembly
 05700-002-64-67

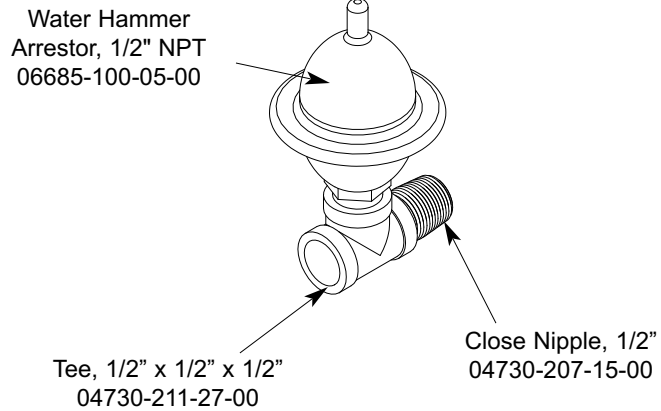

SECTION 5: PARTS SECTION
CONTROL BOX ASSEMBLY

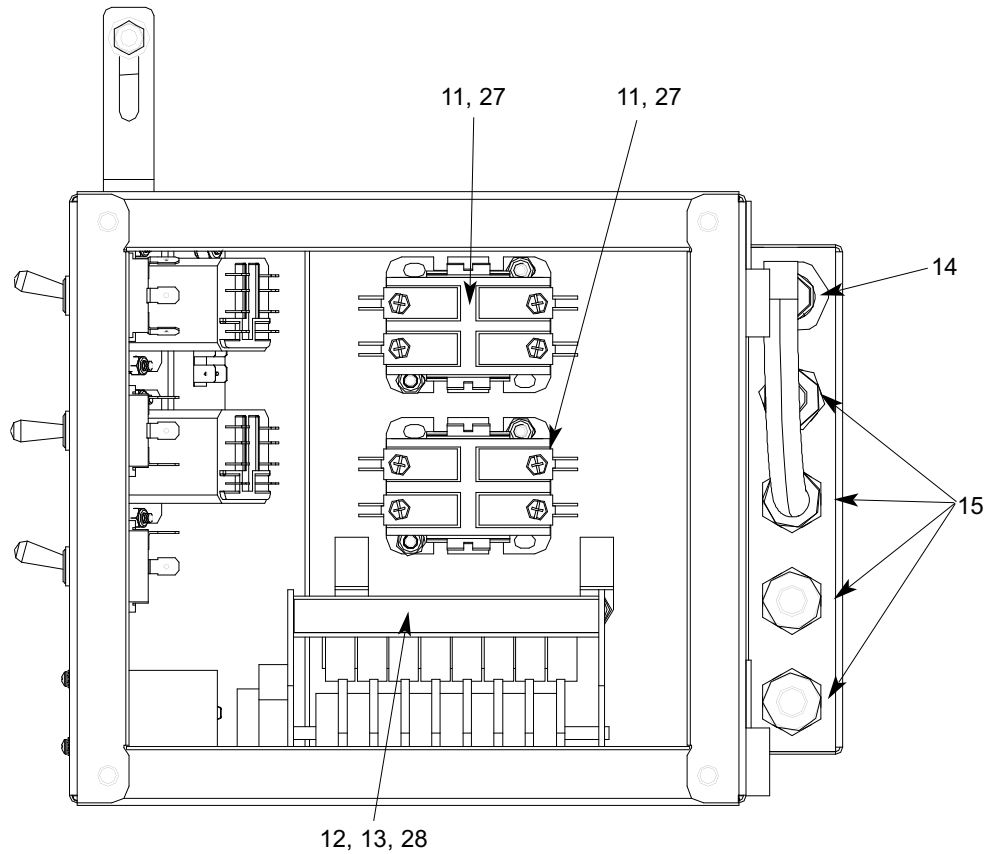
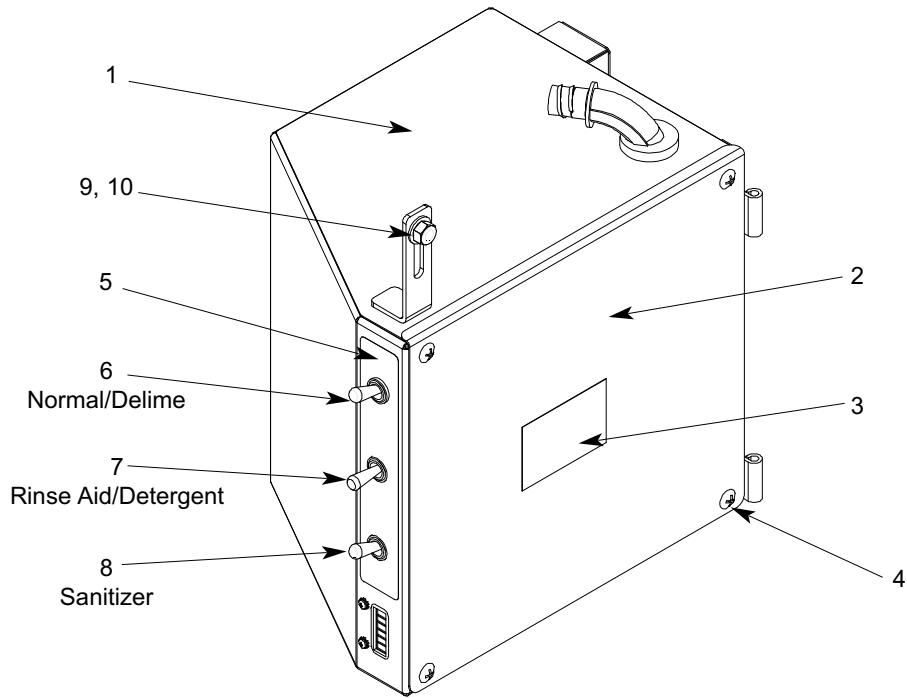

SECTION 5: PARTS SECTION
CONTROL BOX ASSEMBLY

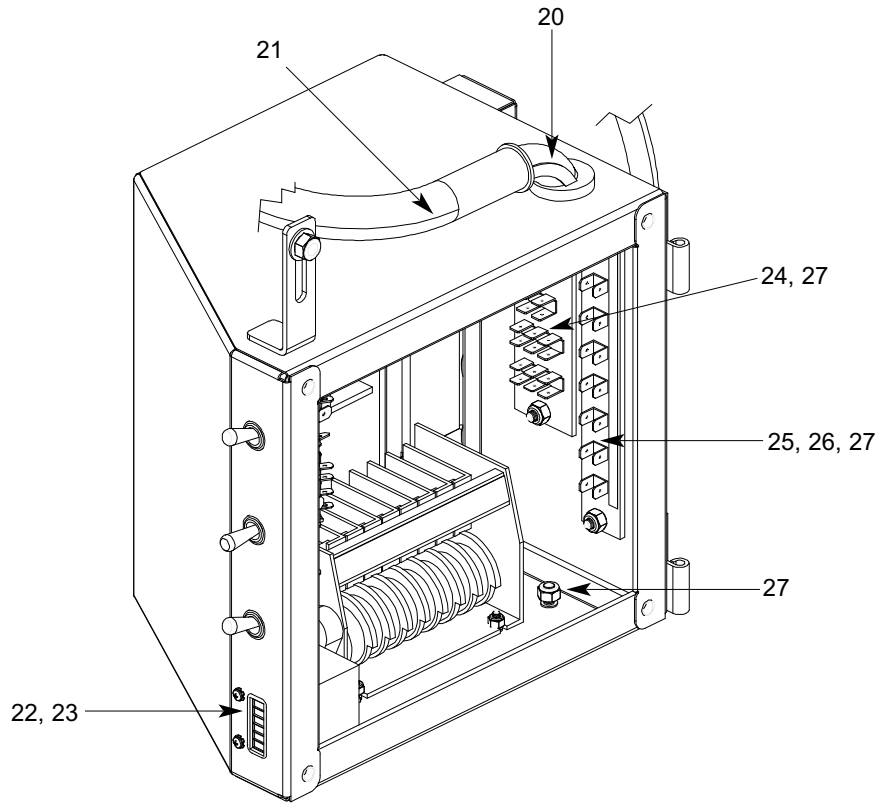
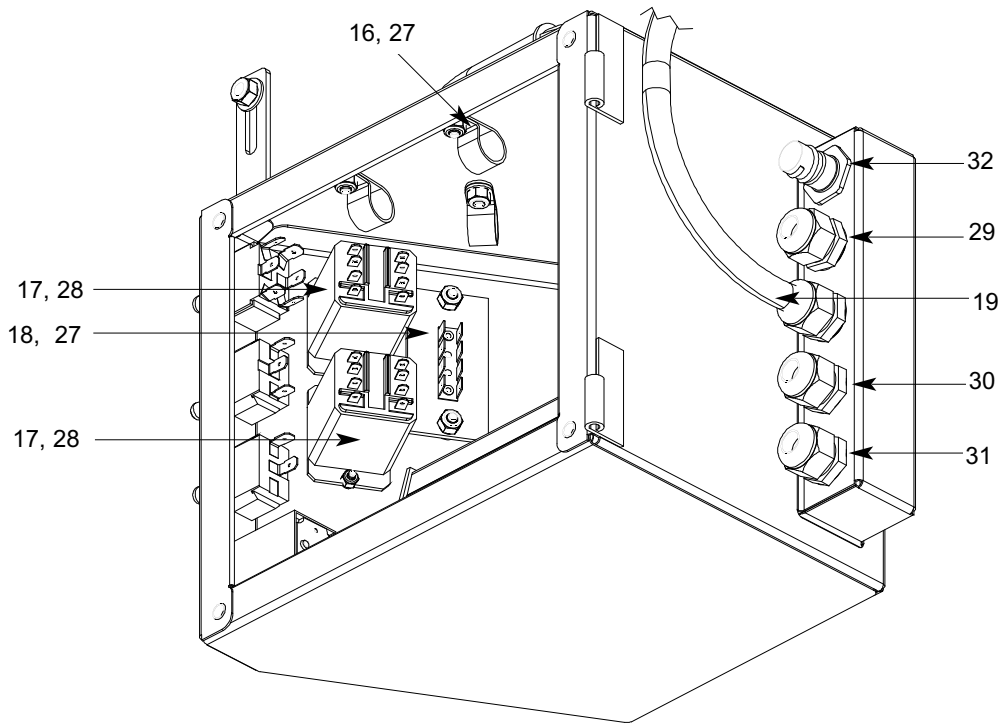

SECTION 5: PARTS SECTION
CONTROL BOX ASSEMBLY (CONTINUED)

ITEM	QTY	DESCRIPTION	Mfg. No.
1	1	Control Box Weldment	05700-003-09-42
2	1	Control Box Cover	05700-003-30-54
3	1	Decal, Warning - Disconnect Power	09905-100-75-93
4	4	Screw, 10-32 x 1/2" Long, Phillips Tusshead	05305-011-39-36
5	1	Decal, Peri-pump Prime	09905-003-32-56
6	1	Switch, Delime/Normal	05930-301-21-18
7	1	Detergent/Rinse Aid Pump Prime Switch	05930-011-35-27
8	1	Sanitizer Pump Prime Switch	05930-111-38-21
9	1	Locknut, 1/4"-20 S/S Hex with Nylon Insert	05310-374-01-00
10	1	Washer, 1/4"-20 S/S	05311-174-01-00
11	2	Contactora	05945-109-05-69
12	1	Timer, 8 Cam	05945-111-35-32
13	1	Decal, Cam Timer	09905-011-37-21
14	4	Fitting, Conduit, Heyco 1/2"	05975-011-49-03
15	1	Fitting, 1/2" Straight Snap In	05975-003-33-27
16	5	Clamp, 5/8" Nylon	04730-011-39-01
17	2	Relay, 2 Pole	05945-111-35-19
18	1	Terminal Board	05940-021-94-85
19	1	Harness, Switch Panel	05700-003-35-37
20	1	Fitting, 1/2" 90 Deg. Snap In	05975-003-33-28
21	1	Conduit, 1/2" x 40"	05700-003-35-48
22	1	Cycle Counter, 115V	05990-111-35-38
23	2	Screw, 4-40 x 1/4" Phillips Pan Head	05305-002-32-38
24	1	Terminal Board	05940-002-78-97
25	1	Terminal Board	05940-001-97-91
26	1	Decal, Terminal Board 8 Position	09905-003-09-30
27	16	Locknut, 10-24 S/S Hex with Nylon Insert	05310-373-01-00
28	6	Locknut, 6-32 S/S Hex with Nylon Insert	05310-373-03-00
29	1	Harness, Wash Pump	05700-003-35-34
30	1	Harness, Drain Solenoid	05700-003-35-36
31	1	Harness, Peri-pump	05700-003-35-35
32	1	Conduit, 1/2" x 17"	05700-003-35-49

SECTION 5: PARTS SECTION

PERI-PUMP BOX ASSEMBLY

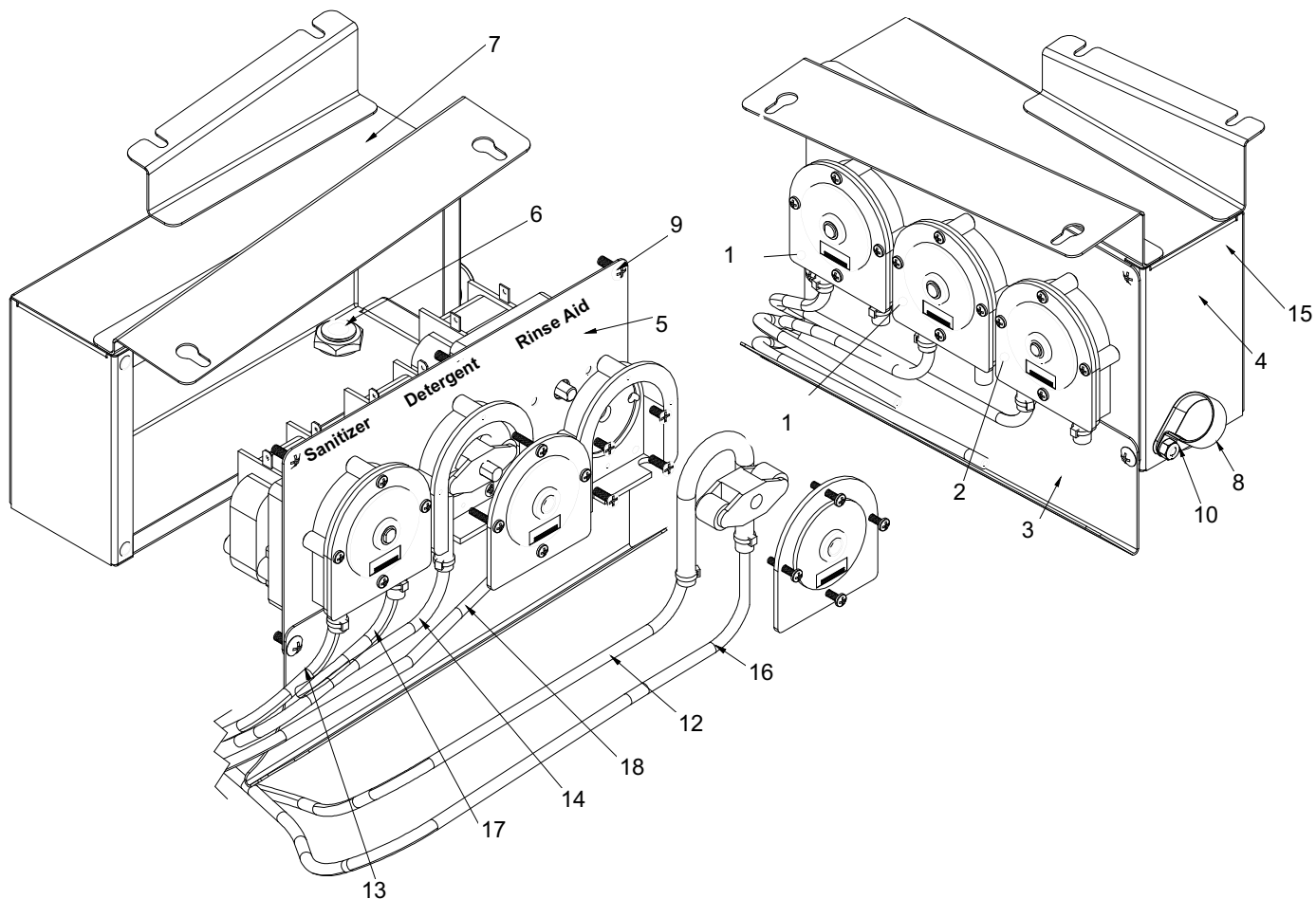

ITEM	QTY	DESCRIPTION	Mfg. No.
1	2	Peri-pump Assembly, 36 RPM	05700-002-96-08
2	1	Peri-pump Assembly, 14 RPM	05700-002-96-09
3	1	Drip Channel	05700-003-32-89
4	1	Weldment, Peri-pump Box	05700-003-32-00
5	1	Weldment, Peri-pump Box Cover	05700-003-33-80
6	1	Fitting, Conduit, Heyco 1/2"	05975-011-65-51
7	1	Clamp, 5/8" Nylon (Located inside of box)	04730-011-39-01
8	1	Clamp, 1" Nylon	04730-002-41-88
9	5	Screw, 10-32 x 1/2" Long, Phillips Tusshead	05305-011-39-36
10	3	Locknut, 10-24 S/S Hex with Nylon Insert	05310-373-01-00
11	3	Tube Stiffener (Not Shown)	05700-002-66-49
12	1	Tubing, 1/4" OD x 60" Long, Blue	05700-002-52-34
13	1	Tubing, 1/4" OD x 60" Long, White	05700-002-52-33
14	1	Tubing, 1/4" OD x 60" Long, Red	05700-011-63-18
15	1	Terminal Board (Not Shown)	05940-001-97-91
16	1	Tubing, 1/4 OD x 120 Long Blue	05700-011-37-17
17	1	Tubing, 1/4 OD x 120 Long Write	05700-011-37-13
18	1	Tubing, 1/4 OD x 120 Long Red	05700-011-37-15

SECTION 5: PARTS SECTION
ELECTRICAL CONNECTION BOX ASSEMBLY

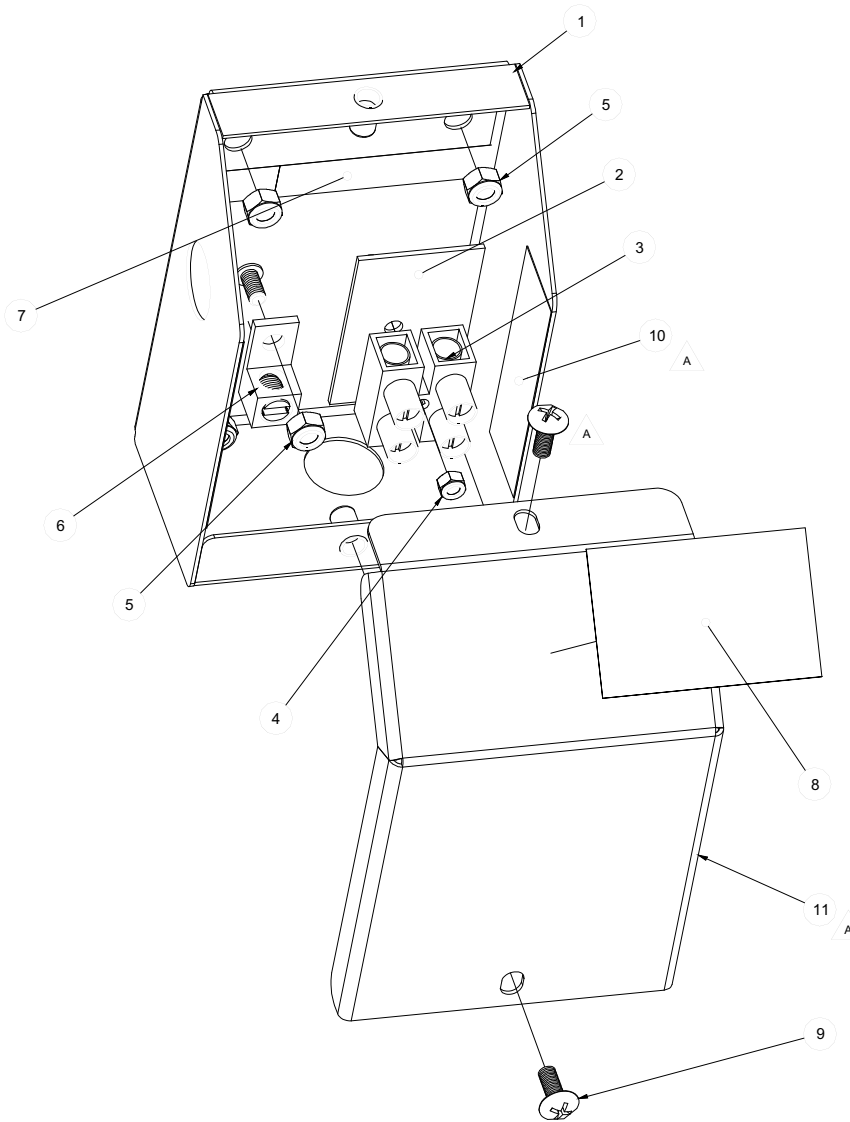

ITEM	QTY	DESCRIPTION	Mfg. No.
1	1	Box, Power Junction Weldment	05700-003-30-58
2	1	Terminal Block Spacer	05700-011-40-05
3	1	Terminal Block	05940-500-09-61
4	1	Locknut, 6-32 with Nylon Insert	05310-373-03-00
5	5	Locknut, 10-24 with Nylon Insert	05310-373-01-00
6	1	Lug, Ground	05940-200-76-00
7	1	Decal, Power Connection	09905-011-47-64
8	1	Decal, Warning to Disconnect Power	09905-100-75-93
9	1	Screw, 10-32 x 1/2" Long, Phillips Trusshead	05305-011-39-36
10	2	Decal, Copper Conductors Only	09905-011-47-35
11	1	Cover, Solenoid Box	05700-003-46-72

SECTION 5: PARTS SECTION
FRAME ASSEMBLY

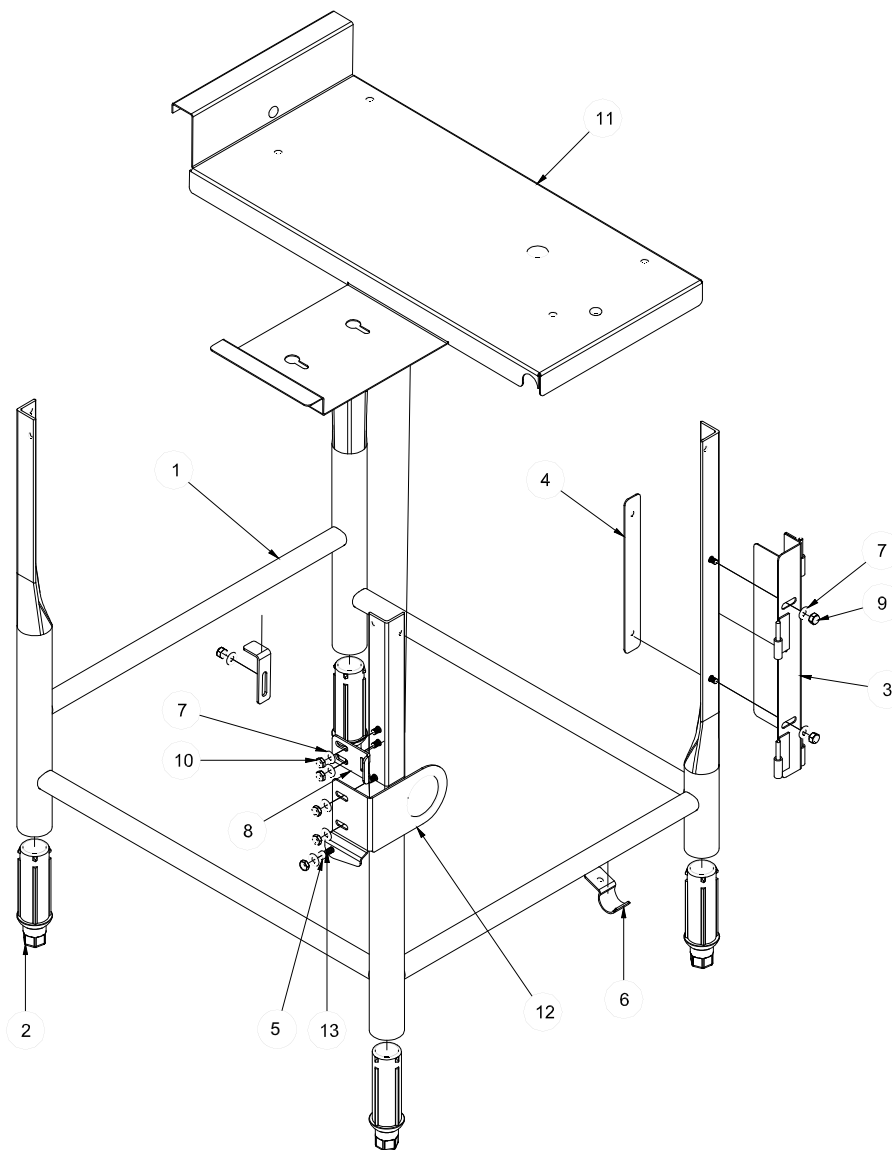

ITEM	QTY	DESCRIPTION	Mfg. No.
1	1	Frame Weldment	05700-003-09-40
2	1	Frame Weldment Double Door	05700-003-28-12
3	4	Foot, 3" Adjustable	05340-002-14-55
4	1	Plate, Hinge Weldment	05700-003-10-11
5	1	Washer, Hinge Weldment	05700-002-54-62
6	1	Spacer, PB Bolt	05700-000-29-40
7	1	Clamp, Pipe	05700-000-35-05
8	8	Washer, 1/4"-20 S/S	05311-174-01-00
9	1	Keeper, Door Panel Latch	05700-003-09-31
10	4	Locknut, 1/4"-20 S/S Hex with Nylon Insert	05310-374-01-00
11	5	Nut, Hex 1/4"-20	05310-274-01-00
12	1	Booster Mounting Plate Weldment	05700-002-51-93
13	1	Bracket, Temperature Gauge	05700-003-14-53
14	1	Bolt, 1/4"-20 x 1/2" Long	05305-274-02-00

SECTION 5: PARTS SECTION
HOOD ASSEMBLY

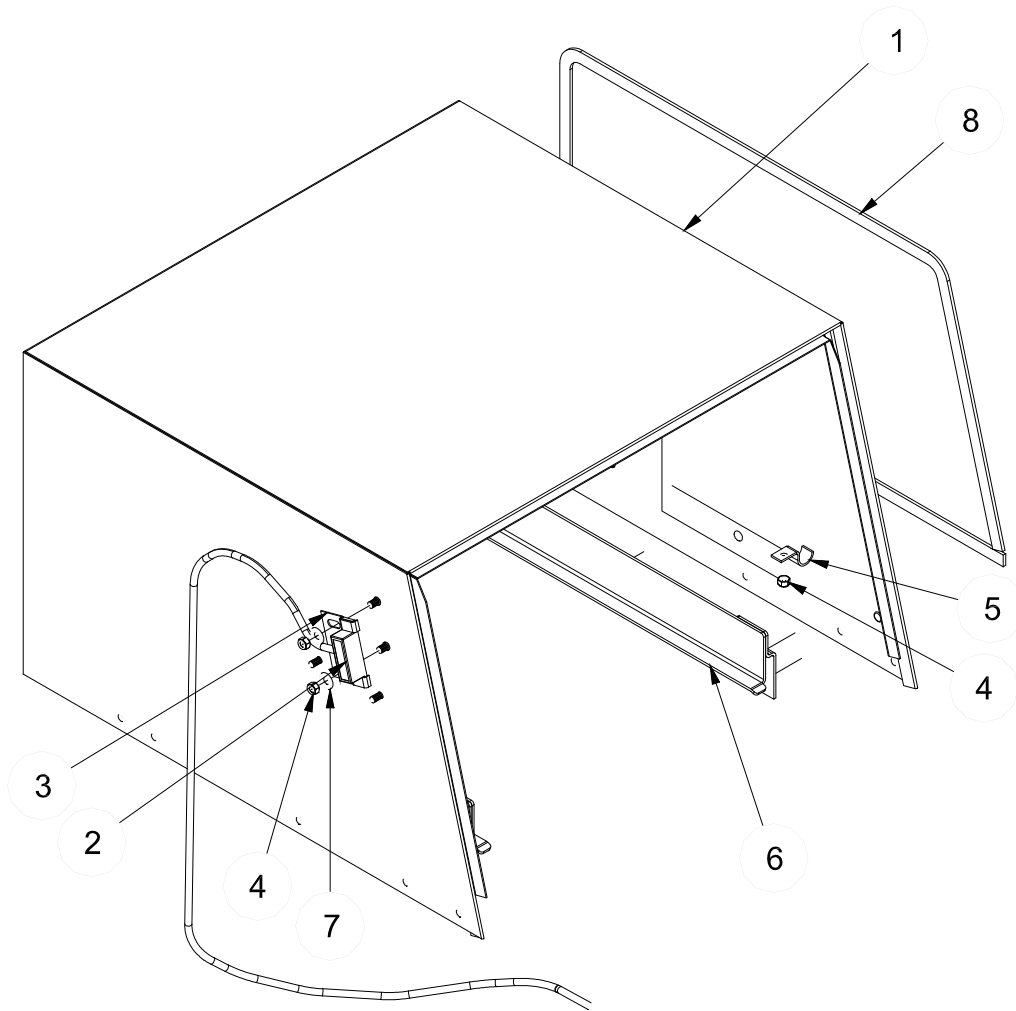

ITEM	QTY	DESCRIPTION	Mfg. No.
1	1	Hood Weldment	05700-003-09-56
1a	1	Hood Weldment Double Door	05700-003-28-17
2	1	Switch, 115V Reed	05930-002-36-80
3	1	Bracket, Limit Switch	05700-021-71-18
4	4	Locknut, 10-24 with Nylon Insert	05310-373-01-00
5	2	Clamp, Pipe 5/8"	05700-000-35-06
6	2	Rack Rail Weldment	05700-002-45-67
7	2	Washer, 1/4"-20 I.D.	05311-174-01-00
8	1	Gasket, Side Panel (5.3 Feet)	05700-003-35-51

SECTION 5: PARTS SECTION
SWITCH PANEL ASSEMBLY

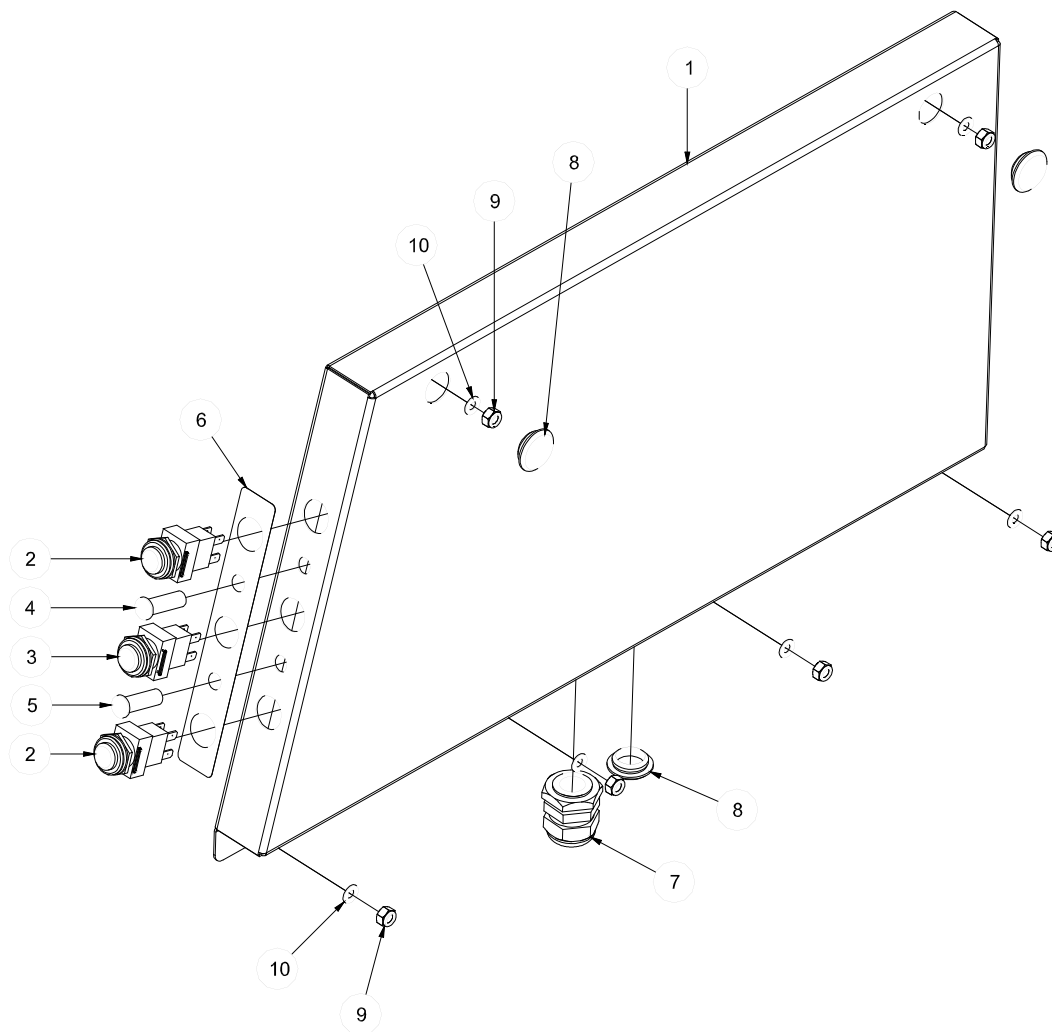

ITEM	QTY	DESCRIPTION	Mfg. No.
		Complete Side Panel Assembly	05700-003-24-38
		Complete Side Panel Assembly (Double Door)	05700-003-24-40
1	1	Side Panel Weldment	05700-003-24-36
1a	1	Side Panel Weldment (Double Door)	05700-003-24-37
2	2 (3)	Switch, Prime Assembly	05700-003-14-91
3	1	Switch, On/Off Assembly	05700-003-14-92
4	1 (2)	Light, Amber	05945-504-06-18
5	1 (2)	Light, Red	05945-504-07-18
6	1	Decal, Switch Panel	09905-003-08-63
7	1	Fitting, .25-.546	05975-011-65-51
8	3 (2)	Plug, 3/4" hole	04730-011-60-21
9	6	Locknut, 10-24 with Nylon Insert	05310-373-01-00
10	6	Washer, #10	05311-173-02-00
11	1	Decal Switch Panel (Double Door Only)	09905-003-38-95
12	1	Fitting (Double Door Only)	05975-011-49-03
13	1	switch (Double Door Only)	05930-002-36-80
14	1	bracket (Double Door Only)	05700-021-71-18
15	1	Terminal Board	05940-001-97-91

ALL NUMBERS THAT ARE IN PARENTHESES ARE FOR THE DOUBLE DOOR

SECTION 5: PARTS SECTION
TUB ASSEMBLY

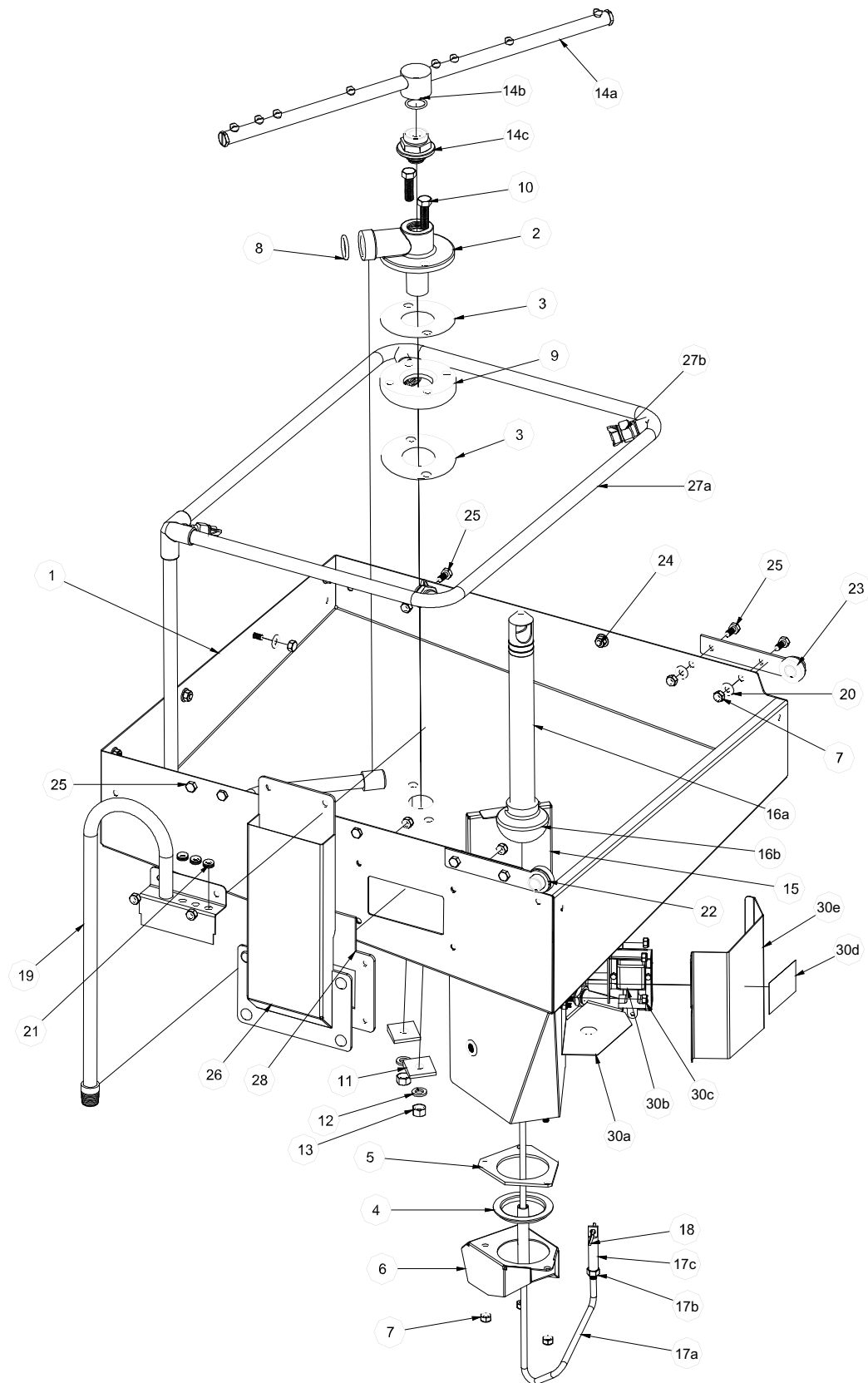

SECTION 5: PARTS SECTION**TUB ASSEMBLY CONTINUED**

ITEM	QTY	DESCRIPTION	Mfg. No.
1	1	Tub Weldment	05700-003-09-51
1a	1	Tub Weldment (Double Door)	05700-003-28-15
2	1	Lower Manifold Weldment	05700-002-45-51
3	2	Manifold Gasket	05700-111-35-03
4	1	Drain Seat Insert	05700-021-34-38
5	1	Spillway Gasket	05700-111-34-52
6	1	Spillway Weldment	05700-031-37-86
7	23	Locknut, 1/4"-20 S/S Hex with Nylon Insert	05310-374-01-00
8	1	Manifold O-Ring	05330-111-35-15
9	1	Modified Casting Wedge	09515-011-46-61
10	2	Bolt, 3/8"-16 x 1 1/4" S/S	05305-276-10-00
11	2	Washer, 3/8" Bevel-Square Iron	05311-011-35-36
12	2	Lockwasher, 3/8"	05311-276-01-00
13	2	Nut, 3/8"-16 S/S Hex	05310-276-01-00
14	1	Complete Wash Arm Assembly	05700-003-31-60
14a	1	Wash Arm Weldment w/ End Plugs	05700-003-31-61
	1	Wash Arm End Plugs	05700-003-31-59
14b	1	Wash Arm O-ring	05330-002-60-69
14c	1	Wash Arm Bearing Assembly	05700-021-35-97
15	1	Sump Strainer	05700-002-60-50
16a	1	Stand Pipe Weldment	05700-021-33-29
16b	1	Stopper, Stand Pipe	05700-121-35-54
17	1	Drain Link Assembly	05700-002-45-52
17a	1	Drain Link	05700-002-40-83
17b	1	Nut, Hex, 5/16"-18	05310-275-01-00
17c	1	Drain Link Connector	05700-002-38-10
18	1	Hair Pin, 1/8" to 1"	05315-011-60-09
19	1	Fill Tube Weldment	05700-002-45-61
20	18	Washer, 1/4"-20 I.D.	05311-174-01-00
21	3	Chemical Tube Grommet	05325-002-42-65
22	1 (2)	Pivot Plate, Left Door Complete Assembly	05700-002-45-62
22a	1	Door Pivot Plate Left Weldment	05700-002-45-63
22b	1	Door Pivot Plate Bearing	03110-002-45-09
23	1 (2)	Pivot Plate, Right Door Complete Assembly	05700-002-52-95
23a	1	Door Pivot Plate Right Weldment	05700-002-52-94
23b	1	Door Pivot Plate Bearing	03110-002-45-09
24	3	Bolt, 1/4"-20 x 1/2" Long	05305-274-02-00
25	6	Screw, 1/4"-20 x 5/8" Long	05305-274-24-00
26	1	Air Gap Weldment	05700-003-23-48
27	1	Halo Assembly	05700-003-23-49
27a	1	Halo Weldment	05700-003-16-65
27b	4	Spray Nozzle and Receptacle	04730-002-55-61
28	1	Gasket, Air Gap	05330-003-24-17
29	2	Clamp, 1" Nylon (Not Shown, located on bottom of tub.)	04730-002-41-88
30	1	Drain Solenoid Box Assembly	05700-003-09-61
30a	1	Solenoid Box Weldment	05700-003-35-88
30b	1	Drain Solenoid, 115V	04810-200-11-00
30c	4	Locknut, 10-24 with Nylon Insert	05310-373-01-00
30d	1	Decal, Warning	09905-100-75-93
30e	1	Solenoid Box Cover	05700-003-30-25

ALL NUMBERS THAT ARE IN PARENTHESES ARE FOR THE DOUBLE DOOR

SECTION 5: PARTS SECTION
FRAME AND MOTOR ASSEMBLY

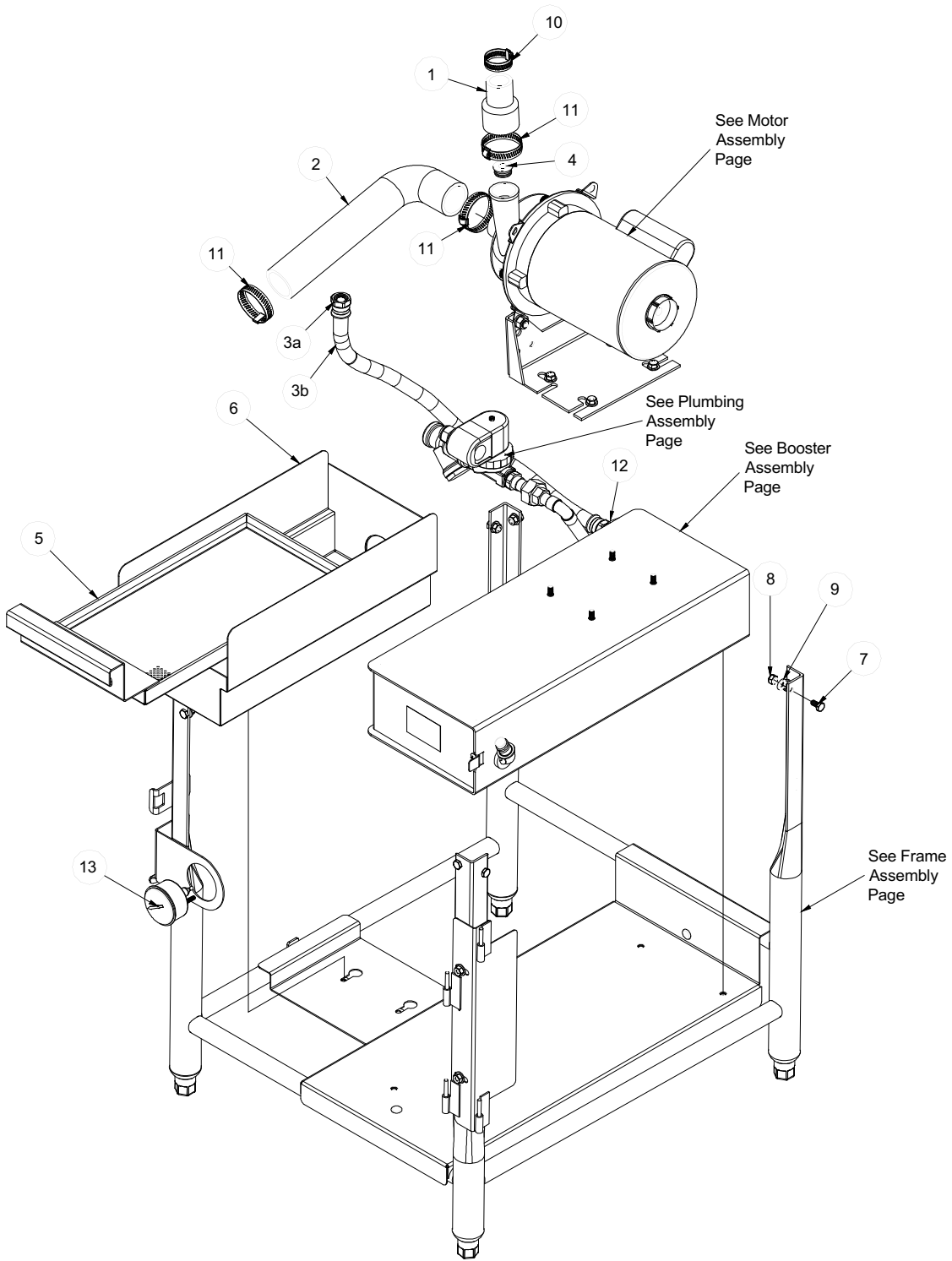

SECTION 5: PARTS SECTION
FRAME AND MOTOR ASSEMBLY (CONTINUED)

ITEM	QTY	DESCRIPTION	Mfg. No.
1	1	Discharge Tube Connector	05700-011-70-34
2	1	Pump Suction Hose	05700-002-40-82
3	1	Discharge Hose Assembly	05700-002-45-58
3a	2	Fitting, 1/2" Pushlock, Female, Brass	04730-011-93-99
3b	1	Hose, 1/2" x 22 1/2" Long	05700-002-45-59
4	1	Wash Restrictor	05700-002-84-69
5	1	Accumulator Strainer Weldment	05700-003-33-25
6	1	Accumulator Weldment	05700-002-51-95
7	8	Bolt, 1/4"-20 x 1/2" Long	05305-274-02-00
8	18	Locknut, 1/4"-20 S/S Hex with Nylon Insert	05310-374-01-00
9	18	Washer, 1/4"-20 S/S	05311-174-01-00
10	1	Hose Clamp, 13/16 TO 1 1/2"	04730-719-06-09
11	3	Hose Clamp, 1 1/16" to 2 1/4"	04730-719-18-00
12	1	Close Nipple, 1/2" Brass	04730-207-15-00
13	1	Gauge, Thermometer	06685-111-68-48

SECTION 5: PARTS SECTION
MOTOR & PUMP ASSEMBLY

Complete Pump & Motor Assembly
Mfg. No.: 06105-002-16-29

Pump Only Assembly
Mfg. No.: 05700-002-79-49

Motor Only
Mfg. No.: 06105-002-79-61

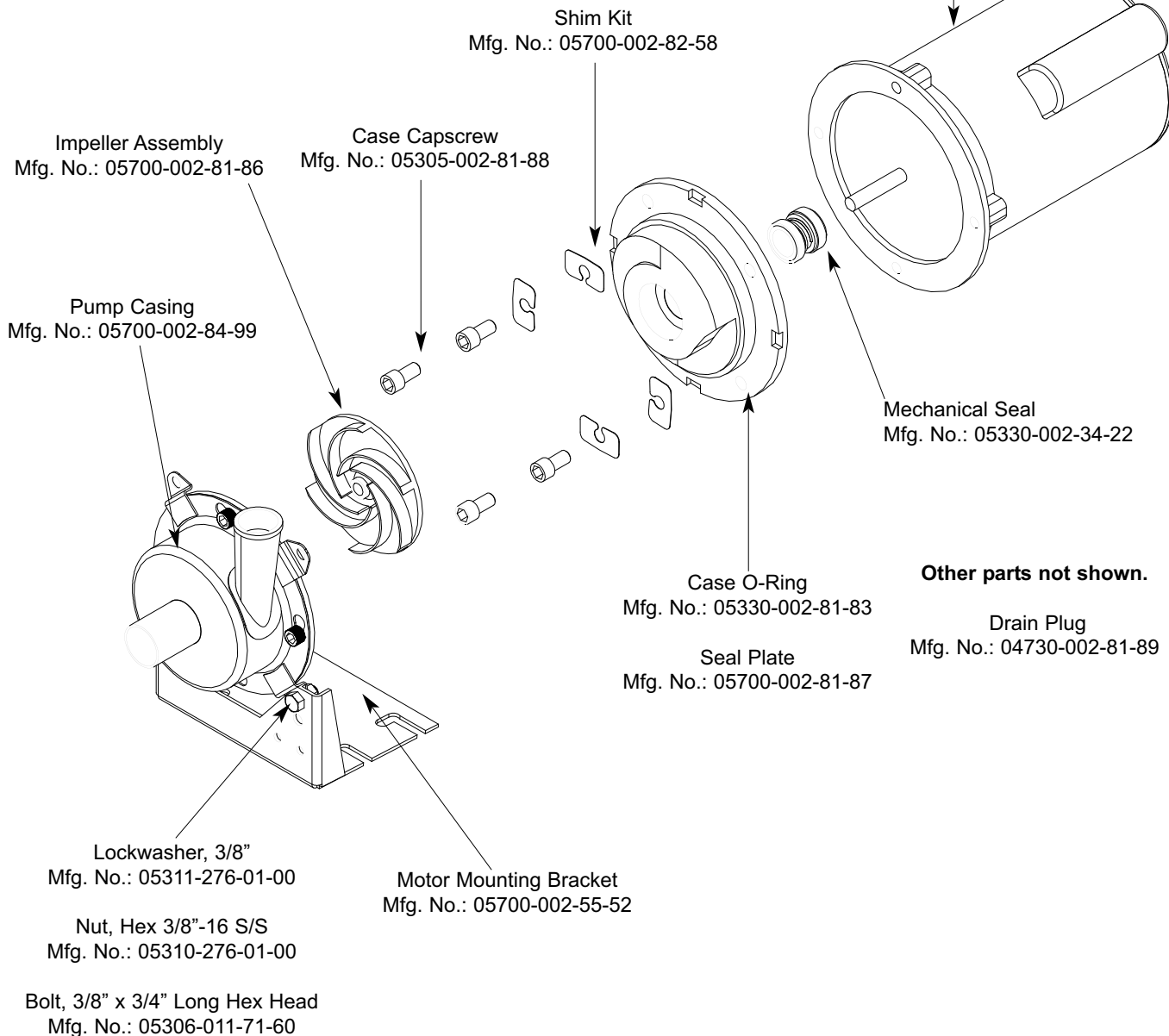

SECTION 5: PARTS SECTION
BOOSTER TANK ASSEMBLY

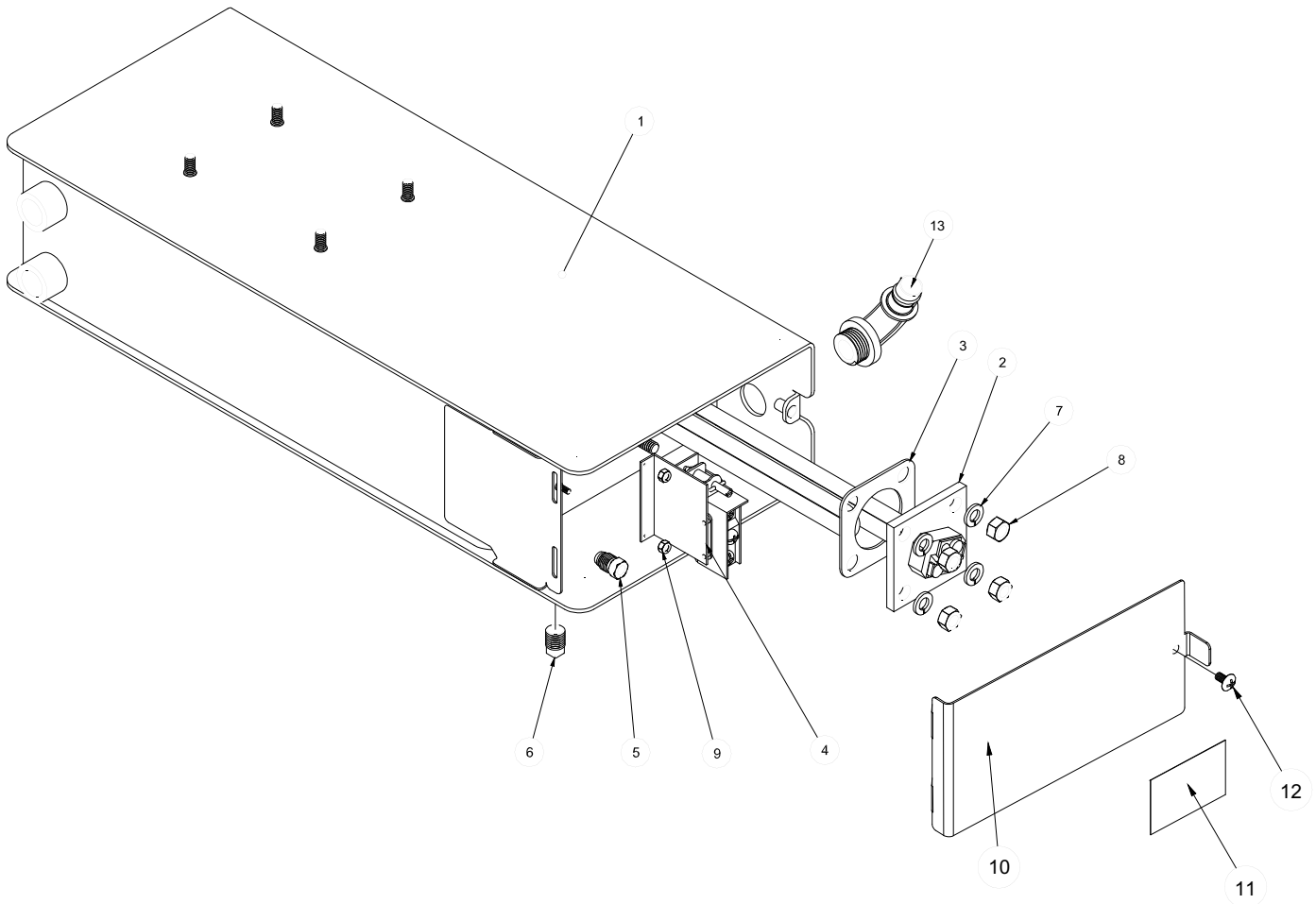

ITEM	QTY	DESCRIPTION	Mfg. No.
1	1	Booster Tank Weldment	05700-002-45-56
2	1	Heater, 120V, 2000 Watts	04540-002-45-13
3	1	Heater Gasket	05330-100-01-10
4	1	Thermostat	05930-003-13-65
5	1	Fitting, Imperial Brass	05310-924-02-05
6	1	Plug, 1/4" Brass	04730-209-01-00
7	4	Lockwasher, 5/16"	05311-275-01-00
8	4	Nut, 5/16"-18 S/S Hex	05310-275-01-00
9	2	Locknut, 6-32 S/S Hex w/ Nylon Insert	05310-373-03-00
10	1	Booster Tank Cover	05700-002-39-07
11	1	Decal, Warning, Disconnect Power	09905-100-75-93
12	1	Screw, 10-32 x 3/8"	05305-173-12-00
13	1	Fitting, 1/2" NPT x 90 Deg. Elbow	05975-003-35-32
13a	1	Nut, 1/2" NPT Nylon	05975-003-35-33

SECTION 5: PARTS SECTION
INCOMING PLUMBING ASSEMBLY

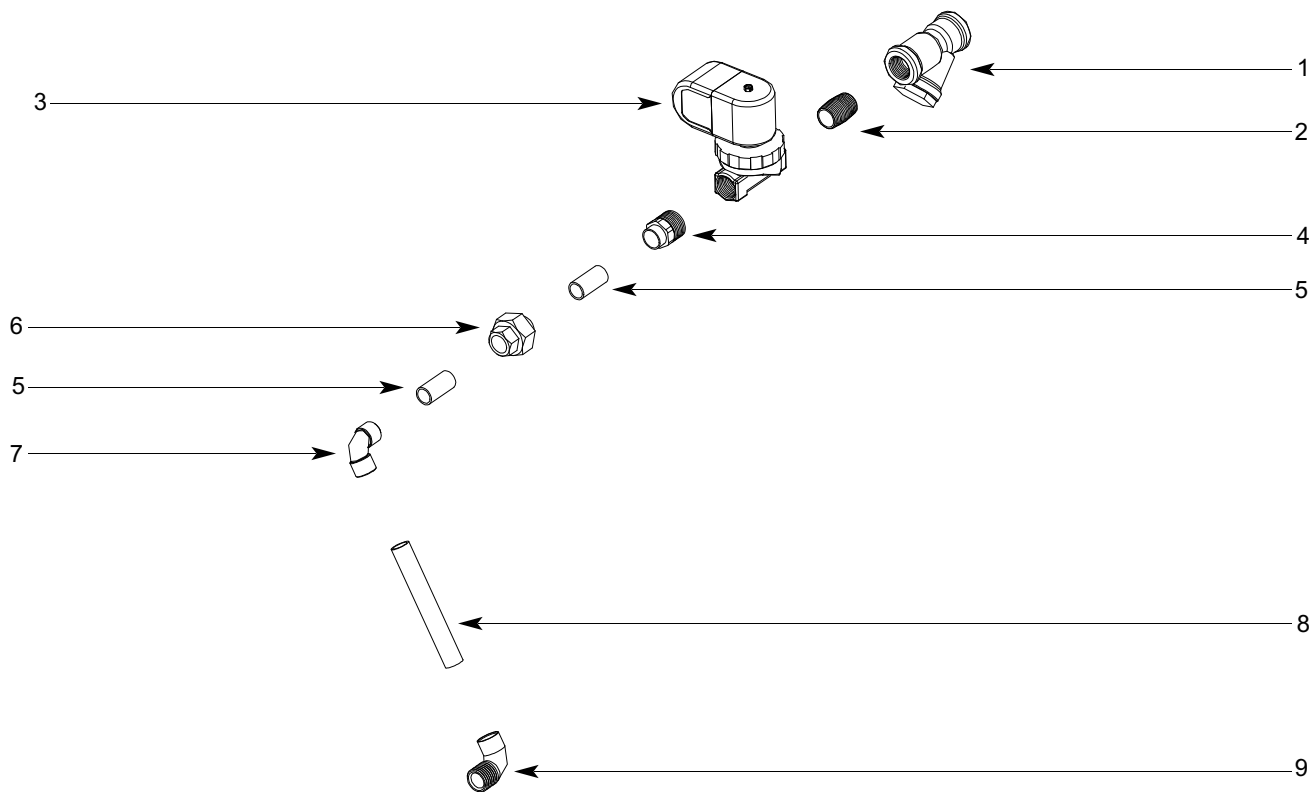

ITEM	QTY	DESCRIPTION	Mfg. No.
1	1	Y-Strainer	04730-217-01-10
2	1	Nipple, Close, 1/2" NPT, Brass	04730-207-15-00
3	1	Valve, Solenoid, 1/2" NPT, 115V	04810-100-12-18
4	1	Adapter, 1/2" Fitting (CU to Male)	04730-401-03-01
5	2	Tube, Copper, 1/2" x 1 1/4" Long	05700-001-08-28
6	1	Union, 1/2", Copper to Copper	04730-412-05-01
7	1	Elbow, 607, 1/2" Copper to Copper	04730-406-01-01
8	1	Tube, Copper, 1/2" x 4 1/4" Long	05700-001-01-60
9	1	Elbow, 90° (CU to MSPS)	04730-406-32-01

SECTION 5: PARTS SECTION
DOOR ASSEMBLY

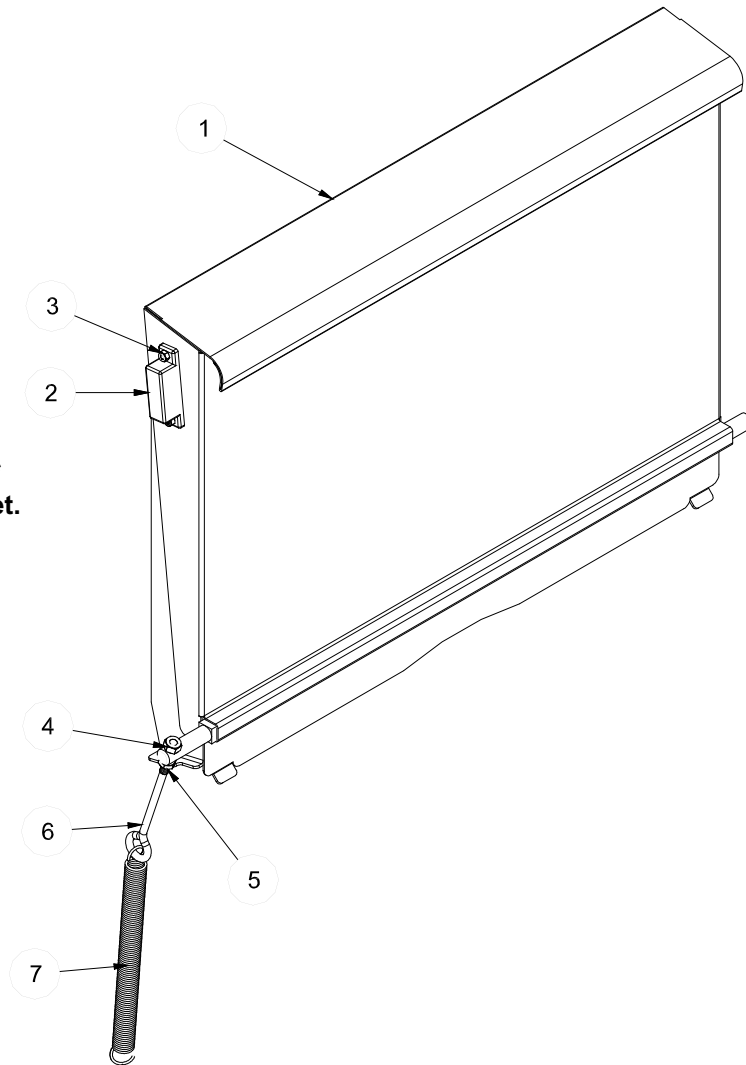

Order kit #***_***_**_**
when replacing magnet.**

ITEM	QTY	DESCRIPTION	Mfg. No.
1	2 (2)	Complete Door Assembly	05700-003-35-30
2	1 (2)	Door Weldment	05700-003-35-29
3	1 (2)	Magnet, Reed Switch	05930-002-68-53
4	1 (2)	Magnet Cover (not shown)	05700-004-07-38
5	2 (2)	Locknut, 6-32 S/S Hex with Nylon Insert	05310-373-03-00
6	1 (4)	Locknut, 1/4\"-20 S/S Hex with Nylon Insert	05310-374-01-00
7	1 (2)	Nut, Hex 1/4\"-20 S/S	05310-274-01-00
8	1 (2)	Bolt, 1/4\"-20 Eye, S/S	05306-002-55-59
9	1 (2)	Spring, Door	05340-011-44-58

ALL NUMBERS THAT ARE IN PARENTHESES ARE FOR THE DOUBLE DOOR

SECTION 5: PARTS SECTION
FRONT PANEL ASSEMBLY

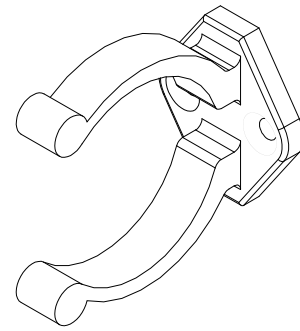
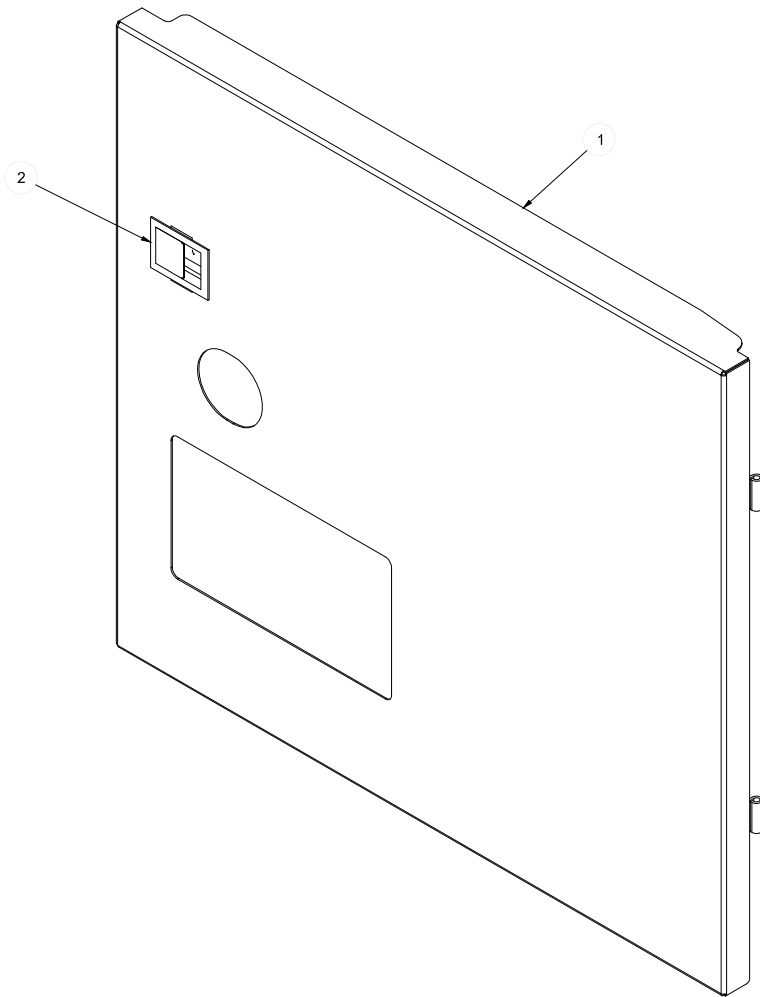

Double Door Only
Panel Clips
2 per machine
05340-003-22-95

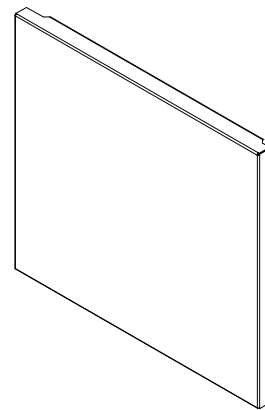

(Double Door Only)
Back Panel Weldment
1 per machine
05700-003-24-42

ITEM	QTY	DESCRIPTION
1	1	Complete Panel Assembly
2	1	Panel Weldment
3	1	Handle
4	1	Back panel weldment
	2	Panel clip

Mfg. No.
05700-003-09-53
05700-003-09-54
05340-001-96-30
05700-002-24-42
05700-033-22-95

SECTION 6: ELECTRICAL SCHEMATICS

SECTION 6: ELECTRICAL SCHEMATICS

DELTA 5 115V, 50/60 HERTZ, SINGLE PHASE (PRIOR TO SERIAL # 14A288762)

DELTA 5 ELECTRICAL DIAGRAM

115 VOLT 50/60 HERTZ 1 PHASE

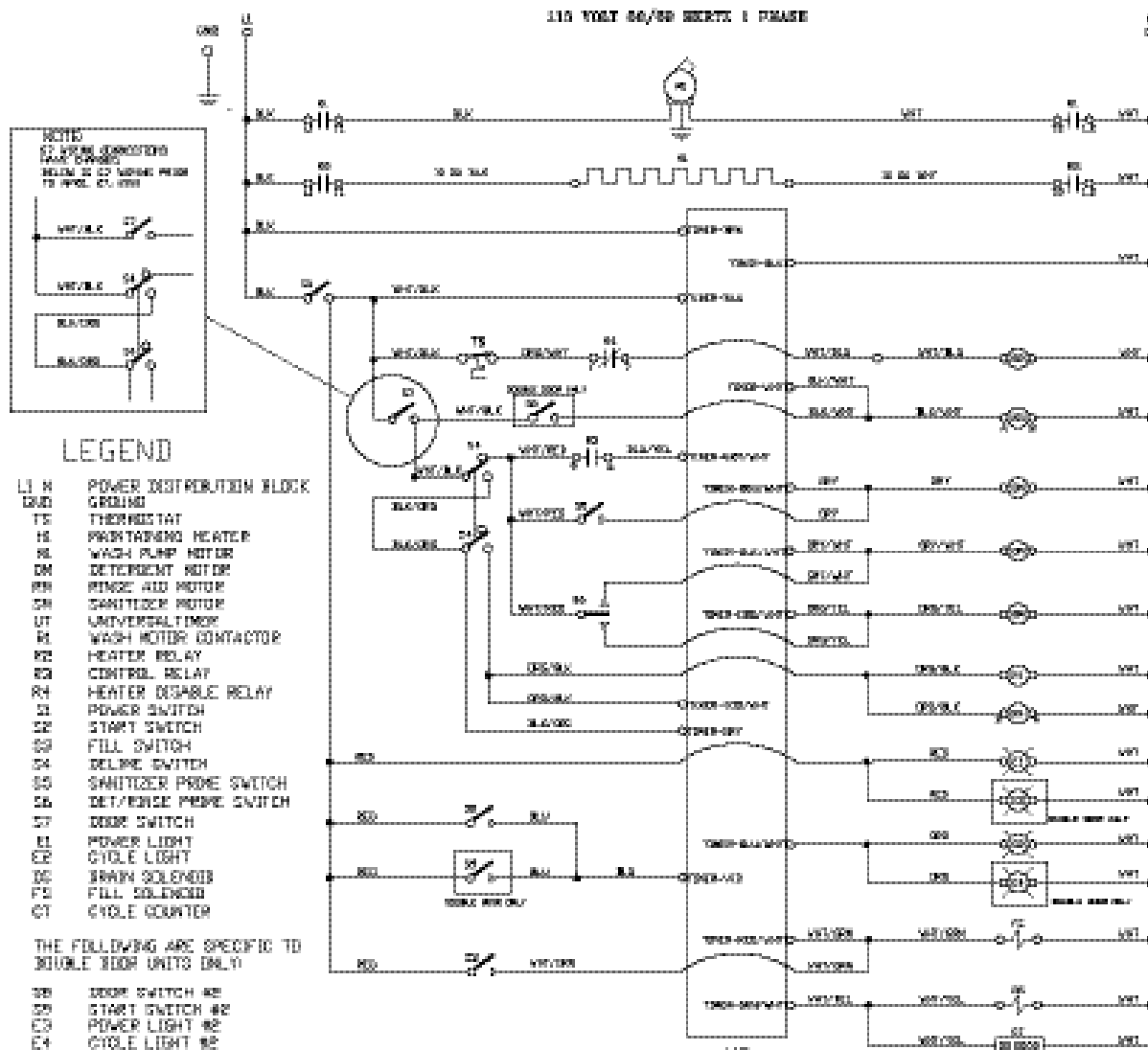

UNIVERSAL TIMER PROGRAM #22
DP SWITCH SETTINGS



TIMING CHART

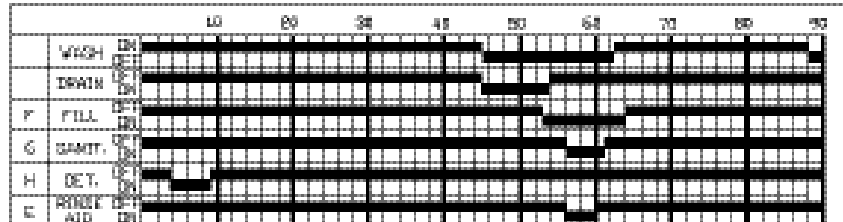

9600-000-36-940

SECTION 6: ELECTRICAL SCHEMATICS

DELTA 5 115V, 50/60 HERTZ, SINGLE PHASE (AFTER SERIAL # 14A288762)

DELTA 5 ELECTRICAL DIAGRAM

115 VOLT 50/60 HERTZ 1 PHASE

NOTE:
S7 WIRING CONNECTIONS
HAVE CHANGED
BELOW IS S7 WIRING PRIOR
TO APRIL 27, 2012

- LEGEND**
- LI N POWER DISTRIBUTION BLOCK
 - GND GROUND
 - TS THERMOSTAT
 - HJ MAINTAINING HEATER
 - M1 WASH PUMP MOTOR
 - DM DETERGENT MOTOR
 - RM RINSE AID MOTOR
 - SM SANITIZER MOTOR
 - UT UNIVERSAL TIMER
 - R1 WASH MOTOR CONTACTOR
 - R2 HEATER RELAY
 - R3 CONTROL RELAY
 - R4 HEATER DISABLE RELAY
 - S1 POWER SWITCH
 - S2 START SWITCH
 - S3 FILL SWITCH
 - S4 DELIME SWITCH
 - S5 SANITIZER PRIME SWITCH
 - S6 DET/RINSE PRIME SWITCH
 - S7 DOOR SWITCH
 - E1 POWER LIGHT
 - E2 CYCLE LIGHT
 - DS DRAIN SOLENOID
 - FS FILL SOLENOID
 - CT CYCLE COUNTER
- THE FOLLOWING ARE SPECIFIC TO
DOUBLE DOOR UNITS ONLY:
- S8 DOOR SWITCH #2
 - S9 START SWITCH #2
 - E3 POWER LIGHT #2
 - E4 CYCLE LIGHT #2

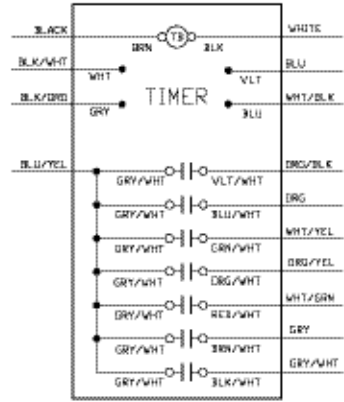
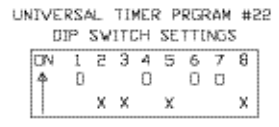
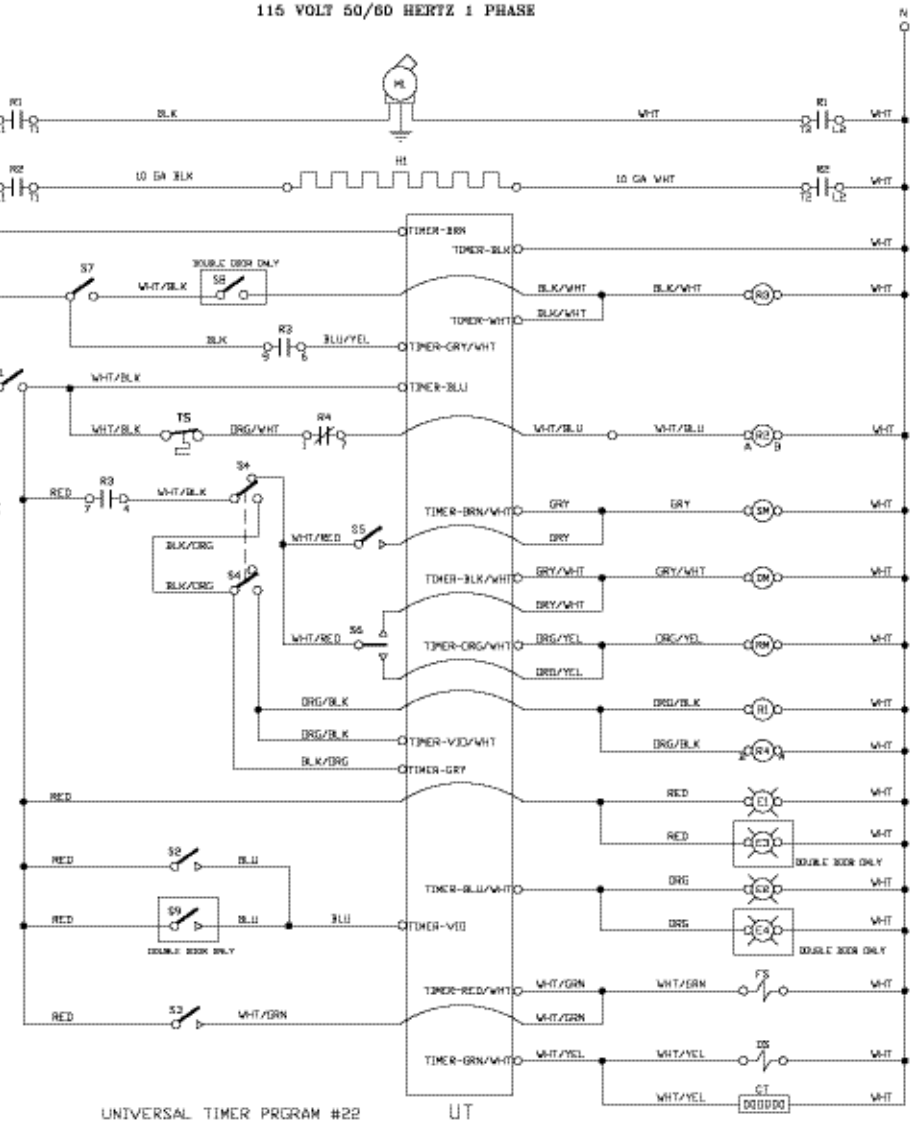

TIMING CHART

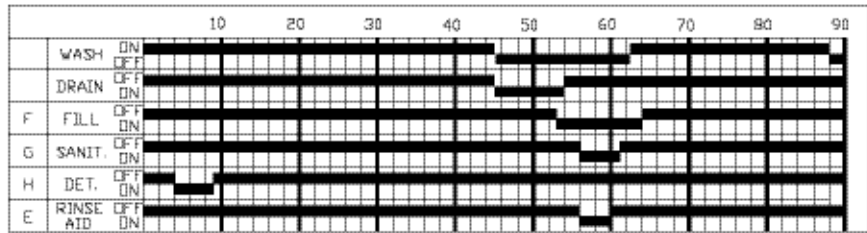

9905-003-36-56C

SECTION 6: ELECTRICAL SCHEMATICS

DELTA 5 115V, 50/60 HERTZ, SINGLE PHASE

DELTA-5 ELECTRICAL DIAGRAM

115 VOLT 50/60 HERTZ 1 PHASE

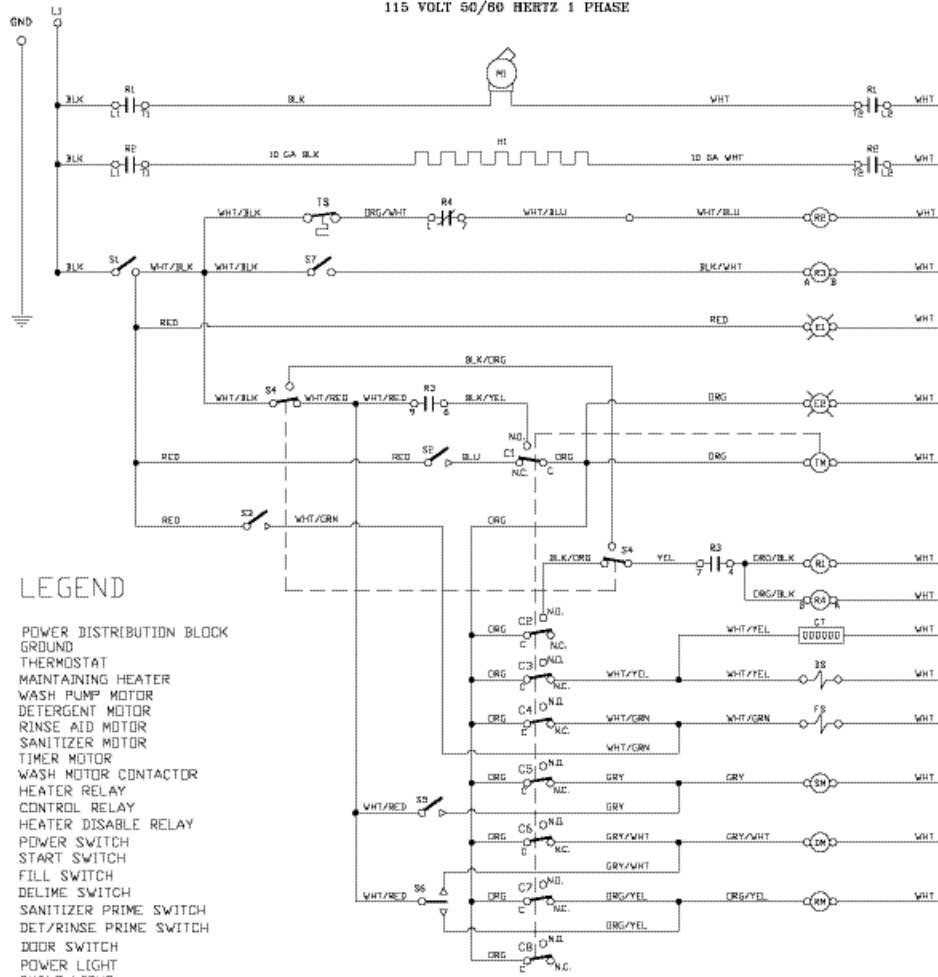

LEGEND

- LI N POWER DISTRIBUTION BLOCK
- GND GROUND
- TS THERMOSTAT
- H1 MAINTAINING HEATER
- M1 WASH PUMP MOTOR
- DM DETERGENT MOTOR
- RM RINSE AID MOTOR
- SM SANITIZER MOTOR
- TM TIMER MOTOR
- R1 WASH MOTOR CONTACTOR
- R2 HEATER RELAY
- R3 CONTROL RELAY
- R4 HEATER DISABLE RELAY
- S1 POWER SWITCH
- S2 START SWITCH
- S3 FILL SWITCH
- S4 DELIME SWITCH
- S5 SANITIZER PRIME SWITCH
- S6 DET/RINSE PRIME SWITCH
- S7 DOOR SWITCH
- E1 POWER LIGHT
- E2 CYCLE LIGHT
- DS DRAIN SOLENOID
- FS FILL SOLENOID
- CT CYCLE COUNTER
- C1 CYCLE/RESET MICROSWITCH
- C2 WASH MICROSWITCH
- C3 DRAIN MICROSWITCH
- C4 FILL MICROSWITCH
- C5 SANITIZER MICROSWITCH
- C6 DETERGENT MICROSWITCH
- C7 RINSE AID MICROSWITCH
- C8 SPARE MICROSWITH

TIMING CHART

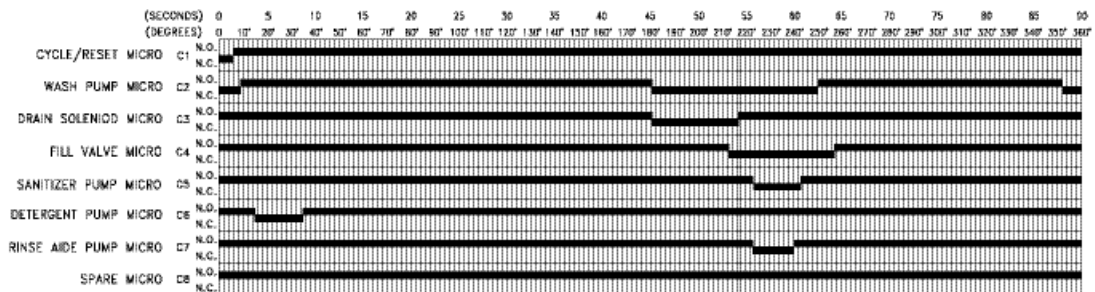

9905-003-36-36D

SECTION 6: ELECTRICAL SCHEMATICS

DELTA 5 HARNESS CONNECTIONS

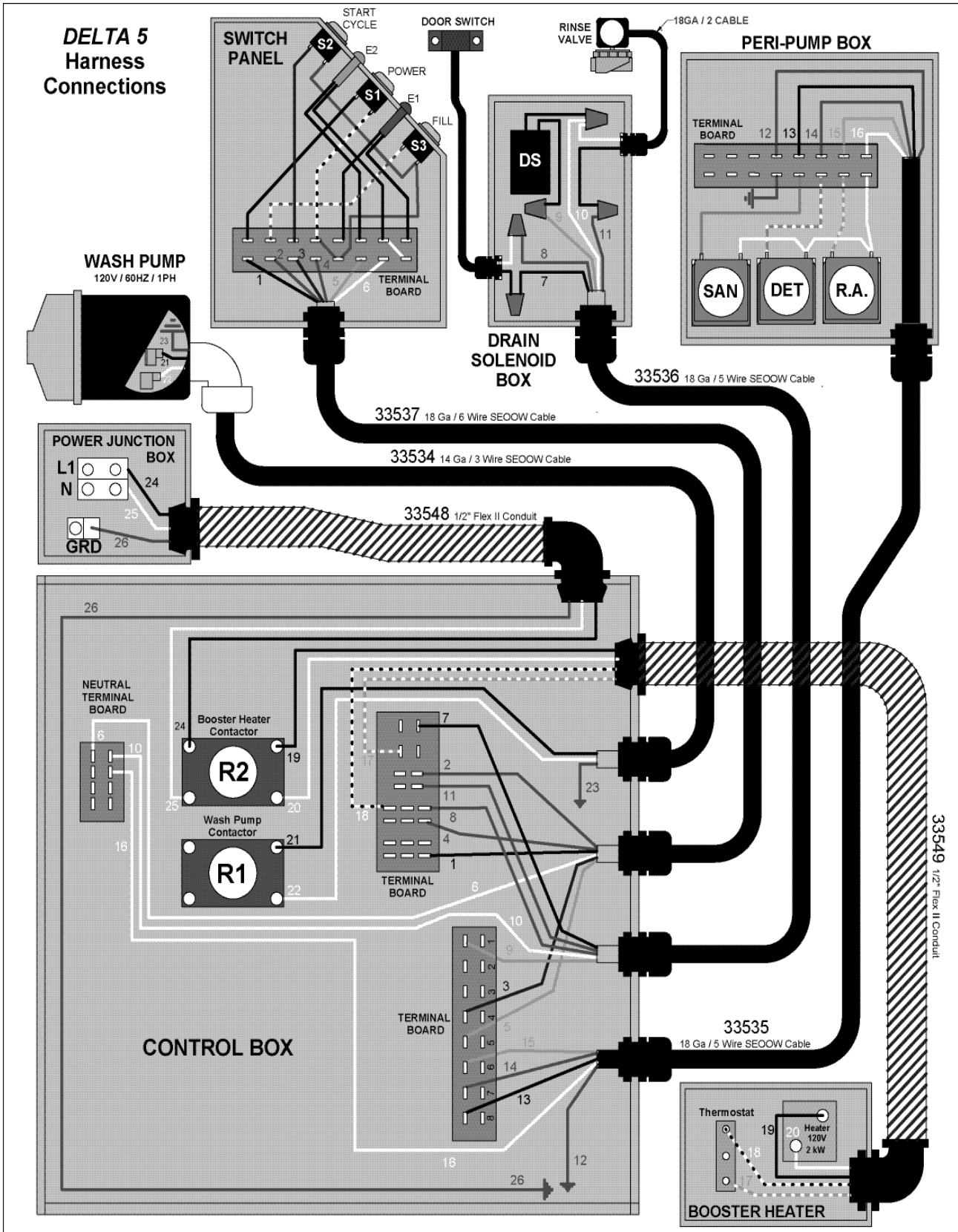

**SECTION 7:
JACKSON MAINTENANCE &
REPAIR CENTERS**

SECTION 7: JACKSON MAINTENANCE & REPAIR CENTERS

ALABAMA TO FLORIDA**ALABAMA**

JONES-McLEOD APPLIANCE SVC
1616 7TH AVE. NORTH
BIRMINGHAM, AL 35203
(205) 251-0159
800-821-1150
FAX: (205) 322-1440
service@jones-mcleod.com

JONES-McLEOD APPLIANCE SVC
854 LAKESIDE DRIVE
MOBILE, AL 36693
(251) 666-7278
800-237-9859
FAX: (251) 661-0223

ALASKA

RESTAURANT APPLIANCE SERVICE
7219 ROOSEVELT WAY NE
SEATTLE, WA 98115
(206) 524-8200
800-433-9390
FAX: (206) 525-2890
info@restappl.com

ARIZONA

AUTHORIZED COMMERCIAL FOOD EQMT. SVC
4832 SOUTH 35TH STREET
PHOENIX, AZ 85040
(602) 234-2443
800-824-8875
FAX: (602) 232-5862
acsboss@aol.com

GCS SERVICE INC.
PHOENIX, AZ
(602) 474-4510
800-510-3497
FAX: (602) 470-4511

ARKANSAS

BROMLEY PARTS & SVC
10TH AND RINGO
P.O. BOX 1688
LITTLE ROCK, AR 72202
(501) 374-0281
800-482-9269
FAX: (501) 374-8352
service@bromleyparts.com
parts@bromleyparts.com

GCS SERVICE, INC.
3717 CHERRY ROAD
MEMPHIS, TN 38118
(901) 366-4587
800-262-9155
FAX: (901) 366-4588

CALIFORNIA

BARKERS FOOD MACHINERY SERVICES
5367 SECOND STREET
IRVINDALE, CA 91706
(626) 960-9390
800-258-6999
FAX: (626) 337-4541
service@barkers.com

GCS SERVICE INC.
LOS ANGELES, CA
(213) 683-2090
800-327-1433
FAX: (213) 683-2099

GCS SERVICE INC.
SANTA ANA, CA
(714) 542-1798
800-540-0719
FAX: (714) 542-4787

GCS SERVICE INC.
S. SAN FRANCISCO, CA
(650) 635-0720
800-969-4427
FAX: (650) 871-4019

COMMERCIAL APPLIANCE SERVICE, INC.
6507 PACIFIC AVENUE, SUITE 102
STOCKTON, CA 95207
(916) 567-0203
(800) 464-2222
(916) 567-0266 FAX

GCS SERVICE INC.
SAN DIEGO, CA
(858) 549-8411
800-422-7278
FAX: (858) 549-2323

INDUSTRIAL ELECTRIC SVC.
5662 ENGINEER DRIVE
HUNTINGTON BEACH, CA 92649
(714) 379-7100
(800-457-3783
FAX: (714) 379-7109

P & D APPLIANCE SVC
100 SOUTH LINDEN AVE.
S. SAN FRANCISCO, CA 94080
(650) 635-1900
800-424-1414
FAX: (650) 635-1919
pndappl@aol.com

P & D APPLIANCE
4220-C ROSEVILLE ROAD
NORTH HIGHLANDS, CA 95660
(916) 974-2772
800-824-7219
FAX:(916) 974-2774

COMMERCIAL APPLIANCE SERVICE, INC.
281 LATHROP WAY, #100
SACRAMENTO, CA 95815
(916) 567-0203
(800) 464-2222
(916) 567-0324 FAX

COLORADO

GCS SERVICE INC.
SHERIDAN, CO
(303) 371-9054
800-972-5314
FAX: (303) 371-4754

HAWKINS COMMERCIAL APPLIANCE SERVICE
3000 S. WYANDOT ST.
ENGLEWOOD, CO 80110
(303) 781-5548
(800) 624-2117
FAX: (303) 761-5561
johns@hawkinscommercial.com

METRO APPLIANCE SERVICE
1640 S BROADWAY
DENVER, CO 80210
(303) 778-1126
800-525-3532
FAX: (303) 778-0268
metroappls@aol.com

CONNECTICUT

GCS SERVICE INC.
HARTFORD, CT
(860) 549-5575
800-423-1562
FAX: (860) 527-6355

SUPERIOR KITCHEN SERVICE INC.
22 THOMPSON ROAD
WINDSOR, CT 06088
(888) 590-1899
(888) 590-1996 FAX

DELAWARE

FOOD SERVICE EQMT.
2101 PARKWAY SOUTH
BROOMALL, PA 19008
(610) 356-6900
FAX: (610) 356-2038
dancerule@aol.com

GCS SERVICE INC.
PHILADELPHIA, PA
(215)925-6217
800-441-9115
FAX: (215) 925-6208

ELMER SCHULTZ SERVICE
36 BELMONT AVE.
WILLMINGTON, DE 19804
(302) 655-8900
800-225-0599
FAX: (302) 656-3673
elmer2@erols.com

EMR SERVICE DIVISION
106 WILLIAMSPORT CIRCLE
SALISBURY, MD 21804
(410) 543-8197
FAX: (410) 548-4038

FLORIDA

COMMERCIAL APPLIANCE SERVICE
8416 LAUREL FAIR CIRCLE
BLDG 6, SUITE 114
TAMPA, FL 33610
(813) 663-0313
800-282-4718
FAX: (813) 663-0212
commercialappliance@worldnet.att.net

GCS SERVICE INC
MIAMI, FL
(305) 621-6666
800-766-8966
FAX: (305) 621-6656

GCS SERVICE INC
ORLANDO, FL
(407) 841-2551
800-338-7322
FAX: (407) 423-8425

NASS PARTS AND SERVICE, INC.
1144 BELVILLE ROAD, UNIT 359
DAYTONA BEACH, FL 32114
(386) 226-2642
(800) 432-2795
(386) 736-7695 FAX

GCS SERVICE INC
TAMPA, FL
(813) 626-6044
800-282-3008
FAX: (813) 621-1174

SECTION 7: JACKSON MAINTENANCE & REPAIR CENTERS

FLORIDA TO MARYLAND

JONES-McLEOD APPLIANCE SVC

854 LAKESIDE DRIVE
MOBILE, AL 36693
(251) 666-7278
800-237-9859
FAX: (251) 661-0223
service@jones-mcleod.com

NASS PARTS AND SERVICE, INC.

1108 SOUTH WOODS AVENUE
ORLANDO, FL 32805
(407) 425-2681
(800) 432-2795
(407) 425-3463 FAX

NASS PARTS AND SERVICE, INC.

1376 HEIDE AVENUE
PALM BAY, FL 32907
(321) 952-2012
(800) 432-2795
(321) 953-0266 FAX

GEORGIA

GCS SERVICE INC

ATLANTA, GA
(770) 452-7322
800-334-3599
FAX: (770) 452-7473

HERITAGE FOODSERVICE GROUP OF ATLANTA

2100 NORCROSS PKWY. SUITE
130
NORCROSS, GA 30071
(770) 368-1465
866-388-9837
FAX: (866) 388-9838

WHALEY FOODSERVICE REPAIRS

109-A OWENS INDUSTRIAL
DRIVE
SAVANNAH, GA 31405
(912) 447-0827
888-765-0036
FAX: (912) 447-0826

PIERCE PARTS & SERVICE

2422 ALLEN ROAD
MACON, GA 31216
(478) 781-6003
800-368-2512
FAX: (478) 781-7186

HAWAII

FOOD EQMT. PARTS & SERVICE CO.

300 PUUHALE RD.
HONOLULU, HI 96819
(808) 847-4871
FAX: (808) 842-1560
fepsco@hula.net

IDAHO

RESTAURANT APPLIANCE SVC.

7219 ROOSEVELT WAY NE
SEATTLE, WA 98115
(206) 524-8200
800-433-9390
FAX: (206) 525-2890
info@restappl.com

RON'S SERVICE

703 E 44TH STREET STE 10
GARDEN CITY, ID 83714
(208) 375-4073
FAX: (208) 375-4402

ILLINOIS

CONES REPAIR SVC.

2408 40TH AVE.
MOLINE, IL 61265
(309) 797-5323
800-716-7070
FAX: (309)797-3631
jackb@cones.com

EICHENAUER SERVICES INC.

130 S OAKLAND ST.
DECATUR, IL 62522
(217) 429-4229
800-252-5892
FAX: (217) 429-0226
esi@esiequality.com

GCS SERVICE INC.

ELMHURST, IL
(630) 941-7800
800-942-9689
FAX: (630) 941-6048

GCS SERVICE INC.

ST. LOUIS, MO
(314) 683-7444
800-284-4427
FAX: (314) 638-0135

GENERAL PARTS, INC.

248 JAMES STREET
BENSONVILLE, IL 60106
(630) 595-3300
(800) 880-3604
FAX: (630)595-0006

INDIANA

GCS SERVICE INC.

INDIANAPOLIS, IN
(317) 545-9655
800-727-8710
FAX: (317) 549-6286

B622 LA PAS TRAIL
INDIANAPOLIS, IN 46268
(317) 290-8060
(800) 410-9794
(317) 290-8085 FAX

IOWA

GOODWIN TUCKER GROUP

2900 DELAWARE AVENUE

DES MOINES, IA 50317
(515) 262-9308
800-372-6066
FAX: (515) 262-2936
parts@goodwintucker.com

CONES REPAIR SVC.

1056 27TH AVENUE SW
CEDAR RAPIDS, IA 52404
(319) 365-3325
800-747-3326
FAX: (319) 365-0885

KANSAS

GCS SERVICE INC.

KANSAS CITY, MO
(816) 920-5999
800-229-6477
FAX: (816) 920-7387

GENERAL PARTS, INC.

1101 E. 13TH STREET
KANSAS CITY, MO 64106
(816) 421-5400
(800) 279-9967
(816) 421-1270 FAX

KENTUCKY

CERTIFIED SERVICE CENTER

127 DISHMAN LANE
BOWLING GREEN, KY 42101
(270) 783-0012
(877) 907-0012
FAX: (270) 783-0058

CERTIFIED SERVICE CENTER

RAMCO BUSINESS PARK

4283 PRODUCE ROAD
LOUISVILLE, KY 40218
(502) 964-7007
800-637-6350
FAX: (502) 964-7202
cwalker@certifiedsc.com
droenigk@certifiedsc.com

CERTIFIED SERVICE CENTER

1051 GOODWIN DRIVE
LEXINGTON, KY 40505
(606) 254-8854
800-432-9269
FAX: (606) 231-7781
jatkins@certifiedsc.com

GCS SERVICE INC.

LOUISVILLE, KY
(502) 367-1788
800-752-6160
FAX: (502) 367-0400

GCS SERVICE INC.

LEXINGTON, KY
(606) 255-0746
800-432-9260
FAX: (606) 255-0748

LOUISIANA

HERITAGE SERVICE GROUP

1532 RIVER OAKS WEST
NEW ORLEANS, LA 70123
(504) 734-8864
(800) 499-2351
(504) 733-2559 FAX

MAINE

GCS SERVICE INC.

CHELSEA, MA
(617) 889-9393
800-225-1155
FAX: (617) 889-1222

MASSACHUSETTS RESTAU- RANT SUPPLY

34 SOUTH STREET
SOMERVILLE, MA 02143
(617) 868-1930
800-338-6737
FAX: (617) 686-5331

PINE TREE FOOD EQUIPMENT

175 LEWISTON ROAD
GRAY, ME 04039
(207) 657-6400
(800) 540-5427
(207) 657-5464 FAX

MARYLAND

EMR SERVICE DIVISION

700 EAST 25TH STREET
BALTIMORE, MD 21218
(410) 467-8080
800-879-4994
FAX: (410) 467-4191
baltparts@emrco.com

SECTION 7: JACKSON MAINTENANCE & REPAIR CENTERS

MARYLAND TO NEW YORK

EMR SERVICE DIVISION
106 WILLIAMSPORT CIRCLE
SALISBURY, MD 21804
(410) 543-8197
888-687-8080
FAX: (410) 548-4038
baltparts@emrco.com

EMR SERVICE DIVISION
5316 Sunnyside Ave.
Beltsville, MD 20715
(301) 931-7000
800-348-2365
FAX: (301) 931-3060
baltparts@emrco.com

GCS SERVICE INC.
SILVER SPRING, MD
(301) 585-7550 (DC)
(410) 792-0338 (BALT)
(800) 638-7278
FAX: (301) 495-4410

MASSACHUSETTS

ACE SERVICE CO.
95 HAMPTON AVE.
NEEDHAM, MA 02494
(781) 449-4220
800-225-4510 MA & NH
FAX: (781) 444-4789
taceservice@aol.com

MASSACHUSETTS RESTAURANT SUPPLY
34 SOUTH STREET
SOMERVILLE, MA 02143
(617) 868-1930
800-338-6737
FAX: (617) 868-5331

GCS SERVICE INC.
CHELSEA, MA
(617) 889-9393
800-225-1155
FAX: (617) 889-1222

GCS SERVICE INC.
HARTFORD, CT
(860) 549-5575
800-723-1562
FAX: (860) 527-6355

SUPERIOR KITCHEN SERVICE INC.
399 FERRY STREET
EVERETT, MA 02149
(617) 389-1899
(888) 590-1899
(617) 389-1996 FAX

MICHIGAN
GCS SERVICE INC.
LIVONIA, MI
(248) 426-9500
800-772-2936
FAX: (248) 426-7555

JACKSON SERVICE COMPANY
3980 BENSTEIN RD.
COMMERCE TWSHP, MI 48382
(248) 363-4159
800-332-4053
FAX: (248) 363-5448

GCS SERVICE INC.
GRAND RAPIDS, MI
(616) 241-0200
800-823-4866
FAX: (616) 241-0541

MINNESOTA

GCS SERVICE INC.
MINNEAPOLIS, MN
(612) 546-4221
800-345-4221
FAX: (612) 546-4286

GENERAL PARTS, INC.
11311 HAMPSHIRE AVENUE
SOUTH
BLOOMINGTON, MN 55438-2456
(952) 944-5800
(800) 279-9980
(800) 279-9980 FAX

MISSISSIPPI

GCS SERVICE INC.
JACKSON, MS
(601) 956-7800
800-274-5954
FAX: (601) 956-1200

GCS SERVICE INC.
MEMPHIS, TN
(901) 366-4587
800-262-9155
FAX: (901) 366-4588

MISSOURI

GCS SERVICE INC.
KANSAS CITY, MO
(816) 920-5999
800-229-6477
FAX: (816) 920-7387

GCS SERVICE INC.
ST. LOUIS, MO
(314) 638-7444
800-284-4427
FAX: (314) 638-0135

KAEMMERLIN PARTS & SVC.
2728 LOCUST STREET
ST. LOUIS, MO 63103
(314) 535-2222
FAX: (314) 535-6205
petek@kps.stl.com

GENERAL PARTS, INC.
1101 EAST 13TH STREET
KANSAS CITY, MO 64106
(816) 421-5400
(800) 279-9967
(816) 421-1270 FAX

MONTANA

RESTAURANT APPLIANCE SVC.
7219 ROOSEVELT WAY NE
SEATTLE, WA 98115
(206) 524-8200
800-433-9390
FAX: (206) 525-2890
info@restappl.com

NEBRASKA

GOODWIN - TUCKER GROUP
7535 D STREET
OMAHA, NE 68124
(402) 397-2880
800-228-0342
FAX: (402) 397-2881
askme@goodwintucker.com

NEVADA

HI TECH COMMERCIAL SERVICE
1840 STELLA LAKE STREET
NORTH LAS VEGAS, NV 89106
(702) 649-4616
(877) 924-4832
FAX: (702) 649-4607
larry@hitechnv.com

5454 LOUIE LANE
RENO, NV 89511
(775) 852-9696
FAX: (775) 852-5104

GCS SERVICE INC.
LAS VEGAS, NV
(702) 450-3495
800-500-9060
FAX: (702) 450-3491

NEW HAMPSHIRE
GCS SERVICE INC.
CHELSEA, MA
(617)889-9393
800-225-1155
FAX: (617) 889-1222

ACE SERVICE CO.
95 HAMPTON AVE.
NEEDHAM, MA 02494
(781) 449-4220
800-225-4510 MA & NH
FAX: (781) 444-4789
taceservice@aol.com

MASSACHUSETTS RESTAURANT SUPPLY
34 SOUTH STREET
SOMERVILLE, MA 02143
(617) 868-1930
800-338-6737
FAX: (617) 868-5331

NEW JERSEY

JAY HILL REPAIRS
90 CLINTON RD.
FAIRFIELD, NJ 07004
(973) 575-9145
800-836-0643
FAX: (973) 575-5890
jhrepair@aol.com

GCS SERVICE INC.
EAST RUTHERFORD, NJ
(973) 614-0003
800-399-8294
FAX: (973) 614-0230

GCS SERVICE INC.
PHILADELPHIA, PA
(215) 925-6217
800-441-9115
FAX: (215) 925-6208

ELMER SCHULTZ SERVICES
201 W. WASHINGTON AVE.
PLEASANTVILLE, NJ 08232
(609) 641-0317
800-378-1641
FAX:(609) 641-8703
elmer2@erols.com

NEW YORK

APPLIANCE INSTALLATION AND SERVICE CORP.
1336 MAIN STREET
BUFFALO, NY 14209
(716) 884-7425
800-722-1252
FAX: (716) 884-0410
ais@worldnet.att.net

SECTION 7: JACKSON MAINTENANCE & REPAIR CENTER

NEW YORK TO PENNSYLVANIA

B.E.S.T. INC.

3003 GENESEE STREET
BUFFALO, NY 14225
(716) 893-6464
800-338-5011
FAX: (716) 893-6466
bestserv@aol.com

DUFFY'S EQUIPMENT SVC.

3138 ONEIDA STREET
SAUQUOIT, NY 13456
(315) 737-9401
800-443-8339
FAX: (315) 737-7132
duffyequip@aol.com

NORTHERN PARTS & SVC.

21 NORTHERN AVENUE
PLATTSBURGH, NY 12903
(518) 563-3200
800-634-5005
FAX: (800) 782-5424
info@northernparts.com

GCS SERVICE INC.

BROOKLYN, NY
(718) 486-5220
800-969-4271
FAX: (718) 486-6772

ALL SERVICE KITCHEN

EQUIPMENT REPAIR
10 CHARLES ST.
NEW HYDE PARK, NY 11040
(516) 378-1176
FAX: (516) 378-1735

ALL ISLAND REPAIRS

40-9 BURT DRIVE
DEER PARK, NY 11729
(631) 242-5588
FAX: (631) 242-6102

NORTH CAROLINA

AUTHORIZED APPLIANCE SERVICECENTER

1020 TUCKASEEGEE RD.
CHARLOTTE, NC 28208
(704) 377-4501
(800) 532-6127
FAX:(704) 377-4504

AUTHORIZED APPLIANCE SERVICECENTER

800 N. PERSON ST.
RALEIGH, NC 27604
(919) 834-3476
FAX:(919) 834-3477

AUTHORIZED APPLIANCE SERVICECENTER

904 S. MARSHALL ST.
WINSTON-SALEM, NC 27403
(336) 725-5396
FAX:(336) 721-1289

AUTHORIZED APPLIANCE SERVICECENTER

104 HINTON AVE.
WILMINGTON, NC 28403
(910) 313-1250
FAX:(910) 313-6130

WHALEY FOODSERVICE

8334-K ARROWRIDGE BLVD
CHARLOTTE, NC 28273
(704) 529-6242
FAX: (704) 529-1558
info@whaleyfoodservice.com

WHALEY FOODSERVICE REPAIRS

203-D CREEK RIDGE RD.
GREENSBORO, NC 27406
(336) 333-2333
FAX: (336) 333-2533
info@whaleyfoodservice.com

WHALEY FOODSERVICE REPAIRS

335-105 SHERWEE DRIVE
RALEIGH, NC 27603
(919) 779-2266
FAX: (919) 779-2224
info@whaleyfoodservice.com

WHALEY FOODSERVICE REPAIRS

6418-101 AMSTERDAM WAY
WILMINGTON, NC 28405
(910) 791-0000
FAX: (910) 791-6662
info@whaleyfoodservice.com

NORTH DAKOTA

GCS SERVICE INC.

MINNEAPOLIS, MN
(612) 546-4221
800-345-4221
FAX: (612) 546-4286

GENERAL PARTS, INC.

10 SOUTH 18TH STREET
FARGO, ND 58103
(701) 235-4161
(800) 279-9987
(701) 235-0539 FAX

OHIO

CERTIFIED SERVICE CENTER

890 REDNA TERRACE
CINCINNATI, OH 45215
(513) 772-6600
800-543-2060
FAX: (513) 612-6600
sbarasch@certifiedsc.com

CERTIFIED SERVICE CENTER

171J-K NORTH HAMILTON RD.
COLUMBUS, OH 43213
(614) 751-3769
(866) 862-1252
FAX: (614) 751-5792
jadkins@certifiedsc.com

CERTIFIED SERVICE CENTER

6025 N. DIXIE DRIVE
DAYTON, OH 45414
(937) 898-4040
(800) 257-2611
FAX: (937) 898-4177
dharvey@certifiedsc.com

COMMERCIAL PARTS & SVC. OF COLUMBUS

5033 TRANSAMERICA DRIVE
COLUMBUS, OH 43228
(614) 221-0057
800-837-8327
FAX: (614) 221-3622

GCS SERVICE INC.

COLUMBUS, OH
(614) 476-3225
800-282-5406
FAX: (614) 476-1196

ELECTRICAL APPLIANCE REPAIR SVC.

5805 VALLEY BELT ROAD
CLEVELAND, OH 44131
(216) 459-8700
800-621-8259
FAX: (216) 459-8707
tomr@electapprep.com

OKLAHOMA

HAGAR RESTAURANT EQMT.

1229 W MAIN STREET
OKLAHOMA CITY, OK 73106
(405) 235-2184
800-445-1791
FAX: (405) 236-5592

OREGON

RON'S SERVICE

16364 SW 72ND AVE
PORTLAND, OR 97224
(503) 624-0890
800-851-4118
FAX: (503) 684-6107
lrobinson@ronsservice.com

PENNSYLVANIA

A.I.S. COMMERCIAL PARTS & SERVICE

1816 WEST 26TH STREET
ERIE, PA 16508
(814) 456-3732
800-332-3732
FAX: (814) 452-4843
aiserie@aol.com

ELMER SCHULTZ SVC.

540 NORTH 3RD STREET
PHILADELPHIA, PA 19123
(215) 627-5400
FAX: (215) 627-5408
elmer2@erols.com

GCS SERVICE INC.

PHILADELPHIA, PA
(215) 925-6217
800-441-9115
FAX: (215) 925-6208

GCS SERVICE INC.

HARRISBURG, PA
(717) 564-3282
800-367-3225
FAX: (717) 564-9286

GCS SERVICE INC.

PITTSBURGH, PA
(412) 787-1970
800-738-1221
FAX: (412) 787-5005

K & D PARTS AND SERVICE CO.

1833-41 N CAMERON STREET
HARRISBURG, PA 17103
(717) 236-9039
800-932-0503
FAX: (717) 238-4367
kdparts-service@paonline.com

CLARK SERVICE & PARTS

306 AIRPORT DRIVE
BOX 10
SMOKETOWN, PA 17576
(717) 392-5590
(717) 392-5735

SECTION 7: JACKSON MAINTENANCE & REPAIR CENTERS

RHODE ISLAND TO WISCONSIN

RHODE ISLAND

GCS SERVICE INC.
EAST PROVIDENCE, RI
(401) 434-6803
800-462-6012
FAX: (401) 438-9400

SUPERIOR KITCHEN SERVICE INC.

669 ELMWOOD AVENUE
PROVIDENCE, RI 02907
(888) 590-1899
(401) 781-1996 FAX

SOUTH CAROLINA

AUTHORIZED APPLIANCE SERVICECENTER

1811 TAYLOR ST.
COLUMBIA, SC 29202
(803) 254-8414
FAX: (803) 254-5146

AUTHORIZED APPLIANCE SERVICECENTER

2249 AUGUSTA RD.
GREENVILLE, SC 29605
(864) 235-9616
FAX: (864) 235-9623

WHALEY FOODSERVICE REPAIRS

I 26&US1
P.O. BOX 4023
WEST COLUMBIA, SC 29170
(803) 791-4420
800-877-2662
FAX: (803) 794-4630
info@whaleyfoodservice.com

WHALEY FOODSERVICE REPAIRS

748 CONGAREE ROAD
GREENVILLE, SC 29607
(864) 234-7011
800-494-2539
FAX: (864) 234-6662
info@whaleyfoodservice.com

WHALEY FOODSERVICE REPAIRS

1406-C COMMERCE PL.
MYRTLE BEACH, SC 29577
(843) 626-1866
FAX: (843) 626-2632
info@whaleyfoodservice.com

WHALEY FOODSERVICE REPAIRS

4740-A FRANCHISE STREET
N. CHARLESTON, SC 29418
(843) 760-2110
FAX: (843) 760-2255
info@whaleyfoodservice.com

SOUTH DAKOTA

GCS SERVICE INC.
MINNEAPOLIS, MN
(612) 546-4221
800-345-4221
FAX: (612) 546-4286

GENERAL PARTS, INC.

10 SOUTH 18TH STREET
FARGO, ND 58103
(701) 235-4161
(800) 279-9987
(701) 235-0539 FAX

TENNESSEE

GCS SERVICE INC.
MEMPHIS, TN
(901) 366-4587
800-262-9155
FAX: (901) 366-4588

GCS SERVICE INC.
NASHVILLE, TN
(615) 244-8050
800-831-7174
FAX: (615) 244-8885

TEXAS

ARMSTRONG REPAIR CENTER
5110 GLENMOUNT DRIVE
HOUSTON, TX 77081
(713) 666-7100
800-392-5325
FAX: (713) 661-0520
gm@armstrongrepair.com

COMMERCIAL KITCHEN REPAIR CO.

1377 N BRAZOS
P.O. BOX 831128
SAN ANTONIO, TX 78207
(210) 735-2811
800-292-2120
FAX: (210) 735-7421
brock@commercialkitchen.com

GCS SERVICE INC.
DALLAS, TX
(972) 484-2954
800-442-5026
FAX: (972) 484-2531

GCS SERVICE INC.
HOUSTON, TX
(713)785-9187
800-868-6957
FAX: (713) 785-3979

GCS/STOVE PARTS

2120 SOLANA STREET
FORT WORTH, TX 76117
(817) 831-0381
800-433-1804
FAX: (817) 834-7754
bud@stoveparts.com

UTAH

LA MONICA'S RESTAURANT

EQMT. SVC.
6182 SOUTH STRATLER AVENUE
MURRAY, UT 84107
(801) 263-3221
800-527-2561
FAX: (801) 263-3229
lamonica81@aol.com

VERMONT

NORTHERN PARTS & SVC.
4874 S. CATHERINE STREET
PLATTSBURGH, NY 12901
(518) 563-3200
800-634-5005
FAX: (800) 782-5424
info@northernparts.com

GCS SERVICE INC.
CHELSEA, MA
(617)889-9393
800-225-1155
FAX: (617) 889-1222

VIRGINIA

DAUBERS, INC.
7645 DYNATECH COURT
SPINGFIELD, VA 22153
(703) 866-3600
800-554-7788
FAX: (703) 866-4071
daubers@aol.com

GCS SERVICE INC.
SILVER SPRING, MD
(301) 585-7550(DC)
(410) 792-0388(BALT)
800-638-7278
FAX: (301)495-4410

GCS SERVICE INC.
RICHMOND, VA
(804) 672-1700
800-899-5949
FAX: (804) 672-2888

GCS SERVICE INC.
VIRGINIA BEACH, VA
(757) 464-3500
800-476-4278
FAX: (757) 464-4106

WASHINGTON

GCS SERVICE INC.
SEATTLE, WA
(206) 763-0353
800-211-4274
FAX: (206) 763-5943

RESTAURANT APPLIANCE SERVICE

7219 ROOSEVELT WAY, NE
SEATTLE, WA 98115
(206) 524-8200
800-433-9390
FAX: (206) 525-2890
info@restappl.com

WEST VIRGINIA

STATEWIDE SERVICE, INC.
603 MAIN AVE.
NITRO, WV 25143
(304) 755-1811
(800) 441-9739
FAX: (304) 755-4001
sws3182@aol.com

WISCONSIN

APPLIANCE SERVICE CENTER, INC.
2439 ATWOOD AVE
MADISON, WI 53704
(608) 246-3160
800-236-7440
FAX: (608) 246-2721
ascmad@execpc.com

APPLIANCE SERVICE CENTER, INC.
6843 W. BELOIT RD.
WEST ALLIS, WI 53219
(414) 543-6460
800-236-6460
FAX: (414) 543-6480
ascmil@execpc.com

APPLIANCE SERVICE CENTER
786 MORRIS AVE
GREEN BAY, WI 54304
(920) 496-9993
800-236-0871
FAX: (920) 496-9927
ascfox@execpc.com

SECTION 7: JACKSON MAINTENANCE & REPAIR CENTERS

WISCONSIN TO WYOMING/INTERNATIONAL

GENERAL PARTS, INC.

W223 N735 SARATOGA DRIVE
WAUKESHA, WI 53186
(262) 650-6666
(800) 279-9946
(262) 650-6660 FAX

WYOMING

HAWKINS COMMERCIAL APPLI- ANCE SERVICE

3000 S. WYANDOT ST.
ENGLEWOOD, CO 80110
(303) 781-5548
(800) 624-2117
FAX: (303) 761-5561
johns@hawkinscommercial.com

METRO APPLIANCE SERVICE

1640 S BROADWAY
DENVER, CO 80210
(303) 778-1126
800-525-3532
FAX: (303) 778-0268
metroappls@aol.com

INTERNATIONAL

GLOBAL PARTS AND SUPPLY

7758 NW 72ND ST
MIAMI, FL 33166
(305) 885-6353

H.D. SHELDON AND CO

19 UNION SQUARE, WEST
NEW YORK, NY 10003
(212) 627-1759
(212) 924-6920

CANADA

THE GARLAND GROUP

1177 KAMATO ROAD
MISSISSAUGA, ONTARIO L4W
1X4
(905) 206-8380
SALES
(905) 624-1419
FAX: (905) 624-1851
SERVICE
800-427-6668
FAX: 800-361-7745

