

# **TECHNICAL MANUAL**

**INSTALLATION MANUAL FOR DOMESTIC UNITS  
INSTALLATION MANUAL FOR EXPORT UNITS  
SERVICE MANUAL FOR DOMESTIC UNITS**

**FOR JACKSON MODELS:**

**HT-1**

**HT-2**

**LT-1**

**LT-3**









## LT-3

- HT-1 = Detergent dispensing unit for high temp dishmachines.
- HT-2 = Detergent and rinse aid dispensing unit for high temp dishmachines.
- LT-1 = Sanitizer dispensing unit for low temp dishmachines.
- LT-3 = Detergent, rinse aid, and sanitizer dispensing unit for low temp dishmachines.

**Model:** \_\_\_\_\_

**Serial No.:** \_\_\_\_\_

**Installation Date:** \_\_\_\_\_

**Service Rep. Name:** \_\_\_\_\_

**Phone No.:** \_\_\_\_\_

Jackson MSC Inc. provides technical support for all of the dishmachines detailed in this manual. We strongly recommend that you refer to this manual before making a call to our technical support staff. Please have this manual with you when you call so that our staff can refer you, if necessary, to the proper page. Technical support is available from 8:00 a.m. to 5:00 p.m. (EST), Monday through Friday. Technical support is not available on holidays. Contact technical support toll free at 1-888-800-5672. Please remember that technical support is available for service personnel only.

SECTION	DESCRIPTION	PAGE
I.	<b>SPECIFICATION INFORMATION</b> Dimensions	2
II.	<b>INSTALLATION/OPERATION INSTRUCTIONS</b> Installation & Operation Instructions, HT-1 & HT-2 Installation & Operation Instructions, LT-1 & LT-3 Installation Instructions & Diagrams, HT-1 & HT-2 Installation Instructions & Diagrams, LT-1 & LT-3 Chemical Dispensing Equipment, HT-1 & HT-2 Chemical Dispensing Equipment, LT-1 & LT-3 Cam Timer Operation HT-1 Cam Timer Operation HT-2 Cam Timer Operation LT-1 Cam Timer Operation LT-3	4 5 7 8 9 10 11 13 15 17
III.	<b>PARTS</b> HT-1 Assembly HT-2 Assembly Inner Panel Assembly LT-1 Assembly LT-3 Assembly Peristaltic Pump Assembly	20 22 24 25 27 29
IV.	<b>ELECTRICAL SCHEMATICS</b> HT-1 208-240V, 60HZ, 1 PHASE HT-2 115V, 60HZ, 1 PHASE HT-2 208-240V, 60HZ, 1 PHASE LT-1 115V, 60HZ, 1 PHASE LT-3 115V, 60HZ, 1 PHASE LT-3 208-240V, 60HZ, 1 PHASE	31 32 33 34 35 36
V.	<b>JACKSON MAINTENANCE &amp; REPAIR CENTERS</b>	38

---

# **SECTION 1: SPECIFICATION INFORMATION**

DIMENSIONS

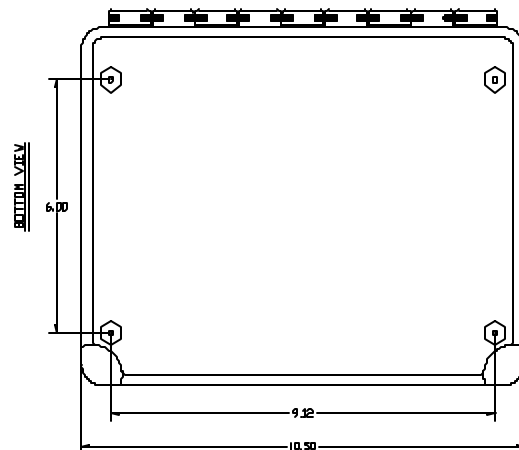
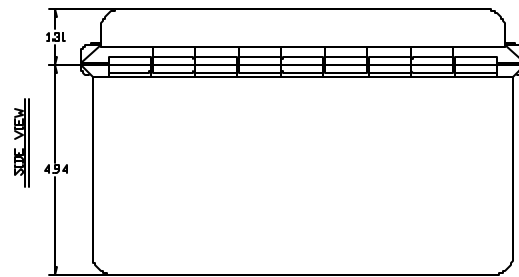
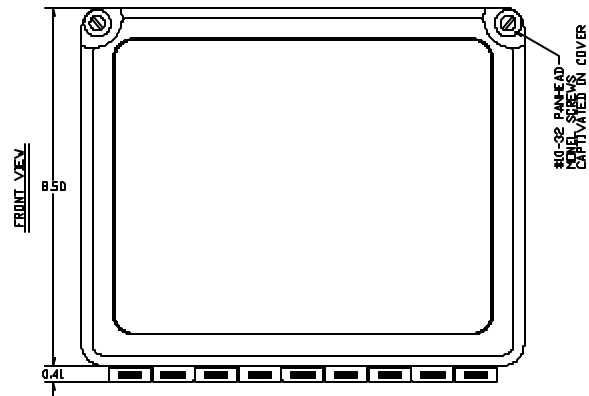

---

**SECTION 2:  
INSTALLATION/OPERATION  
INSTRUCTIONS**



### INSTALLATION/OPERATION INSTRUCTIONS HT-1 & HT-2 DISPENSERS

Mount the chemical dispenser unit in a convenient location on the wall.



**VERY IMPORTANT:** Do not use a domestic type detergent in this machine at any time. This type of detergent may damage and/or obstruct pump operation or cause corrosion in the tank.

**HT-1 DISPENSING EQUIPMENT- ELECTRICAL CONNECTION:** Power and signal source for the detergent and rinse aid are provided as follows:

1. **DETERGENT SIGNAL**-White/red wire, signal (line voltage) for detergent dispensing. Connected between the normally closed contact (N.C.) of C6 cam and the Detergent Pump Motor (SM) also connecting to the Detergent Prime Switch (S4). Detergent will be dispensed during the rinse cycle.

2. **DISPENSER POWER**-White wire (line voltage). Connected between Detergent Primer Switch (S4) and the On/Fill-Off/Drain Switch (S1).

All conduit and wiring for the interconnections is shipped pre-mounted to the HT-1 Chemical Dispensing Equipment. For connections to the dishmachine the wires terminate with butt splice connectors. When installing the chemical dispensing wiring match the correct wire colors then crimp the connectors.

**HT-2 DISPENSING EQUIPMENT- ELECTRICAL CONNECTION:** Power and signal source for the detergent and rinse aid are provided as follows:

1. **DETERGENT SIGNAL**-White/red wire, signal (line voltage) for detergent dispensing. Connected between the normally closed contact (N.C.) of C6 cam and the detergent terminal of the Speed Control Circuit Board (SC). Detergent will be dispensed during the rinse cycle.

2. **DISPENSER POWER**-Red wire, (line voltage) Connected between "L2" and the "C" terminal on the step-down transformer in the HT-2 box.

3. **DISPENSER POWER**-White wire (line voltage). Connected between "L1" and the appropriate line voltage terminal on the step-down transformer in the HT-2 box.

4. **RINSE AID SIGNAL**-Blue wire, (line voltage). Signal for dispensing the rinse aid. Connected between the normally closed contact (N.C.) of the C5 cam and the rinse aid terminal of the Speed Control Circuit Board (SC). Rinse aid will be injected into the final rinse line during the rinse cycle.

All conduit and wiring for the interconnections is shipped pre-mounted to the HT-2 Chemical Dispensing Panel. For connections to the dishmachine the wires terminate with butt splice connectors. When installing the chemical dispensing wiring match the correct wire colors then crimp the connectors.

**DETERGENT RECOMMENDATIONS:** We suggest that you contact your local detergent specialist for the correct detergent for your area.

**LIQUID DETERGENT DISPENSING POINT:** Liquid detergent will be dispensed into machine from factory supplied hole at back of the tub above the basket strainer. Remove factory installed plug and install injector fitting for the detergent.

**RINSE ADDITIVE INJECTION-FINAL RINSE LINE (HT-2 ONLY):** Rinse Aid will be injected into the final rinse line at the rear of the machine. Remove one of the 1/4" plugs from the line and install the rinse aid injector fitting.

**TIMER ADJUSTMENT FOR DETERGENT CONCENTRATION:** The amount of detergent may need to be increased or decreased depending on water quality and type of detergent. It is factory set to dispense 15 ml of detergent into the wash water during the rinse cycle. Consult your detergent representative for adjustment.

**VOLTAGE CHECK:** Ensure that the power switch is in the OFF position and apply power to the dishmachine. Check the incoming power at the terminal block and ensure it corresponds to the voltage listed on the data plate of the dishmachine. If not, contact a qualified service agency to examine the problem. Do not run the dishmachine if the voltage is too high or too low. Shut off the service breaker and mark it as being for the dishmachine. Advise all proper personnel of any problems and of the location of the service breaker. Replace the front kick panel and tighten down the screws.

## SECTION 2: INSTALLATION/OPERATION INSTRUCTIONS

### INSTALLATION / OPERATION INSTRUCTIONS LT-1 & LT-3 DISPENSERS

The dishmachine is a "DUMP AND FILL" type unit that dumps (drains) the wash water after each washing cycle. Water added from the fresh water final rinse is used for the next washing cycle.

Mount the chemical dispenser unit in a convenient location on the wall.



**VERY IMPORTANT:** Do Not use a domestic type detergent in this machine at any time. This type of detergent may damage and/or obstruct pump operation or cause corrosion in the tank.

**LT-1 DISPENSING EQUIPMENT- ELECTRICAL CONNECTION:** Power and signal source for the sanitizer are provided as follows:

1. **SANITIZER SIGNAL**-White/red wire, signal (line voltage) for sanitizer dispensing. Connected between the normally closed contact (N.C.) of C6 cam and the Sanitizer Pump Motor (SM) also connecting to the Sanitizer Prime Switch (S4). Sanitizer will be dispensed during the rinse cycle.

2. **DISPENSER POWER**-White wire (line voltage). Connected between Sanitizer Primer Switch (S4) and the On/Fill-Off/Drain Switch (S1).

All conduit and wiring for the interconnections is shipped pre-mounted to the LT-1 chemical dispensing equipment. For connections to the dishmachine the wires terminate with butt splice connectors. When installing the chemical dispensing wiring match the correct wire colors then crimp the connectors.

**LT-3 DISPENSING EQUIPMENT- ELECTRICAL CONNECTION:** Power and signal source for the detergent and rinse aid are provided as follows:

1. **SANITIZER SIGNAL**-White/red wire, signal (line voltage) for sanitizer dispensing. Connected between the normally closed contact (N.C.) of C6 cam and the Sanitizer Pump Motor (SM) also connecting to the Sanitizer Prime Switch (S4). Sanitizer will be dispensed during the rinse cycle.

2. **DISPENSER POWER**-White wire (line voltage). Connected between Sanitizer Primer Switch (S4) and the On/Fill-Off/Drain Switch (S1).

3. **DETERGENT SIGNAL**-White/red wire, signal (line voltage) for detergent dispensing. Connected between the normally closed contact (N.C.) of C7 cam and the Detergent Pump Motor (DM) also connecting to the Detergent Prime Switch (S5). Detergent will be dispensed during the rinse cycle.

4. **DISPENSER POWER**-White wire (line voltage). Connected between Detergent Primer Switch (S5) and the On/Fill-Off/Drain Switch (S1).

5. **RINSE ADDITIVE SIGNAL**-White/red wire, signal (line voltage) for rinse additive dispensing. Connected between the normally closed contact (N.C.) of C8 cam and the Rinse Aid Pump Motor (RM) also connecting to the Rinse Aid Prime Switch (S6). Rinse Aid will be dispensed during the rinse cycle.

6. **DISPENSER POWER**-White wire (line voltage). Connected between Rinse Aid Primer Switch (S6) and the On/Fill-Off/Drain Switch (S1).

All conduit and wiring for the interconnections is shipped pre-mounted to the LT-3 chemical dispensing panel. For connections to the dishmachine the wires terminate with butt splice connectors. When installing the chemical dispensing wiring match the correct wire colors then crimp the connectors.

**SANITIZER RECOMMENDATIONS:** We suggest that you contact your local chemical specialist for the correct sanitizer for your application.

**DETERGENT RECOMMENDATIONS AND RINSE ADDITIVES (LT-3 Only):** We suggest that you contact your local detergent specialist for the correct detergent and rinse additives for your area.

## SECTION 2: INSTALLATION/OPERATION INSTRUCTIONS

---

### INSTALLATION / OPERATION INSTRUCTIONS LT-1 & LT-3 DISPENSERS (CONTINUED)

**LIQUID DETERGENT DISPENSING POINT (LT-3 Only):** Liquid detergent will be dispensed into machine from factory supplied hole at back of the tub above the basket strainer. Remove factory installed plug and install injector fitting for the detergent.

**TIMER ADJUSTMENT FOR DETERGENT CONCENTRATION (LT-3 Only):** The amount of detergent may need to be increased or decreased depending on water quality and type of detergent. It is factory set to dispense 15 ml of detergent into the wash water during the rinse cycle. Consult your detergent representative for adjustment.

**RINSE ADDITIVE INJECTION-FINAL RINSE LINE (LT-3 ONLY):** Rinse Aid will be injected into the final rinse line at the rear of the machine. Remove one of the 1/4" plugs from the line and install the rinse aid injector fitting.

**SANITIZER INJECTION-FINAL RINSE LINE:** Sanitizer will be injected into the final rinse line at the rear of the machine. Remove one of the 1/4" plugs from the line and install the sanitizer injector fitting.

**TIMER ADJUSTMENT FOR SANITIZER CONCENTRATION:** The amount of sanitizer may need to be increased or decreased depending on concentration and type of sanitizer used. The dispenser needs to be able to provide 2.271 ml of a 10% Chlorine sanitizer for every machine cycle.

**VOLTAGE CHECK:** Ensure that the power switch is in the OFF position and apply power to the dishmachine. Check the incoming power at the terminal block and ensure it corresponds to the voltage listed on the data plate of the dishmachine. If not, contact a qualified service agency to examine the problem. Do not run the dishmachine if the voltage is too high or too low. Shut off the service breaker and mark it as being for the dishmachine. Advise all proper personnel of any problems and of the location of the service breaker. Replace the front kick panel and tighten down the screws.

## SECTION 2: INSTALLATION/OPERATION INSTRUCTIONS

### INSTALLATION INSTRUCTIONS & DIAGRAMS for the HT-1 & HT-2

#### Installation Instructions:

1. Identify the appropriate location for the box.
2. Make sure the electrical supply to the dishmachine has been turned off at the supply circuit breaker.
3. Loosen the two screws in the upper corners of the box and open. (See photo #1)
4. Loosen and remove the four screws to the component mounting plate inside. (Removing the ground screw will give additional slack.) (See photo #2)
5. Hold the box up to the wall and mark four mounting holes. (See photo #3)
6. Install appropriate wall anchors for the type of wall.
7. Mount the box to the wall.
8. Replace the component mounting plate. Reinstall the ground screw.
9. Close the box and retighten screws.
10. Run flexible conduit to rear of dishmachine and attach with fitting provided.
11. Remove the front kick panel from the dishmachine by loosening the screws under the front two corners and lifting upward and out.
12. Locate the wire bundle above the thermostat. (See photo #4) There will be four wires (white, red, blue and white with a red stripe) all with red crimp-type butt splices.
13. Run the five wires from the conduit to the front of the unit and match up color to color with the wire bundle. Cut wires from the conduit to proper length, if needed.
14. Crimp all wires to matching color on dishmachine. Attach green and yellow wire to grounding lug. Use wire ties to route wires out of the way of moving parts.
15. Reinstall the kick panel on the dishmachine.
16. Locate and remove the white bulkhead plug on the rear of the dishmachine.
17. Install the bulkhead fitting from the kit (bulkhead with a hole through the center) in its place. (See photo #5) Install one of the compression elbows into the bulkhead fitting. Route the red chemical tube into the compression elbow and hand tighten only.
18. Locate the rinse injector on the rear of the dishmachine. Remove one of the square headed plugs. Wrap the compression elbow threads with plumber's teflon tape and install the elbow into the hole.
19. Insert a short piece of clear tubing from the kit into the other compression elbow. Route the white tubing from the dispenser to the compression elbow. Insert white tube through clear tube in compression elbow and hand tighten only. (See photo #6)
20. Power up the unit and run a cycle and check for leaks.
21. Put the unit back in place.
22. Place the gray stiffeners in the appropriate chemicals. (red for detergent, and white for rinse aid)
23. Prime each pump until chemical is seen flowing through tube going into the unit.
24. Installation is complete.



Photo #1

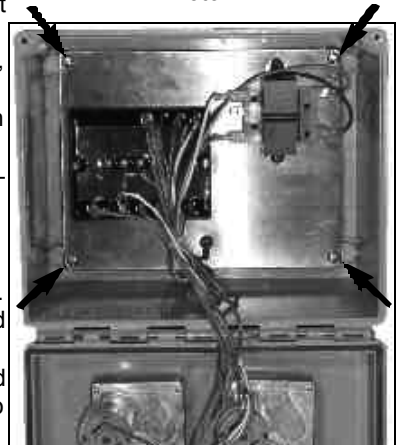

Photo #2

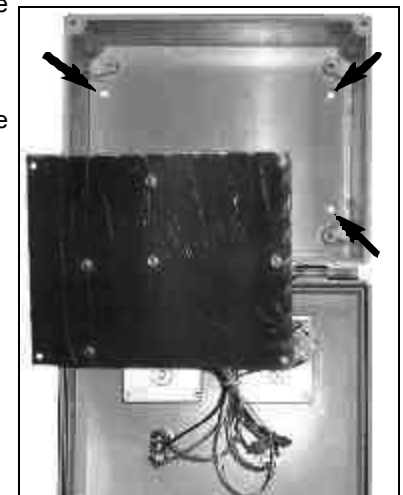

Photo #3



Photo #4



Photo #5

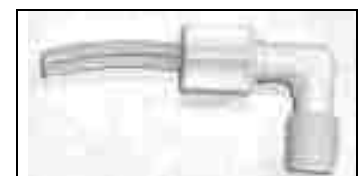

Photo #6

## SECTION 2: INSTALLATION/OPERATION INSTRUCTIONS

### INSTALLATION INSTRUCTIONS & DIAGRAMS for the LT-1 & LT-3

1. Identify the appropriate location for the box.
2. Make sure the electrical supply to the dishmachine has been turned off at the supply circuit breaker.
3. Loosen the two screws in the upper corners of the box and open. (See diagram #1)
4. Hold the box up to the wall and mark four mounting holes. (See diagram #2)
5. Install appropriate wall anchors for the type of wall.
6. Mount the box to the wall.
7. Close the box and retighten screws.
8. Run flexible conduit to rear of dishmachine and attach with fitting provided.
9. Remove the front kick panel from the dishmachine by loosening the screws under the front two corners and lifting upward and out.
10. Locate the wire bundle above the thermostat. There will be four wires (white, red, blue and white with a red stripe) all with red crimp-type butt splices.
11. Run the five wires from the conduit to the front of the unit and match up color to color with the wire bundle. Cut wires from the conduit to proper length, if needed.
12. Crimp all wires to matching color on dishmachine. Attach green and yellow wire to grounding lug. Use wire ties to route wires out of the way of moving parts.
13. Reinstall the kick panel on the dishmachine.
14. Locate and remove the white bulkhead plug on the rear of the dishmachine.
15. Install the bulkhead fitting from the kit (bulkhead with a hole through the center) in its place. (See diagram #3) Install one of the compression elbows into the bulkhead fitting. Route the red chemical tube into the compression elbow and hand tighten only.
16. Locate the rinse injector on the rear of the dishmachine. Remove one of the square headed plugs. Wrap the compression elbow threads with plumber's teflon tape and install the elbow into the hole.
17. Insert a short piece of clear tubing from the kit into the other compression elbow. Route the white tubing from the dispenser to the compression elbow. Insert white tube through clear tube in compression elbow and hand tighten only. (See diagram #4)
18. Power up the unit and run a cycle and check for leaks.
19. Put the unit back in place.
20. Place the gray stiffeners in the appropriate chemicals. (red for detergent, and white for sanitizer, and blue for rinse aid)
21. Prime each pump until chemical is seen flowing through tube going into the unit.
22. Installation is complete.

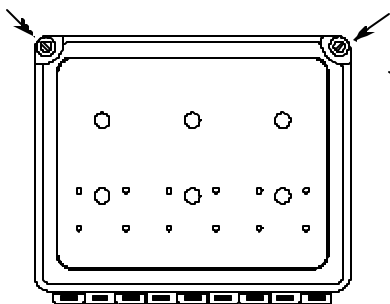

Diagram #1

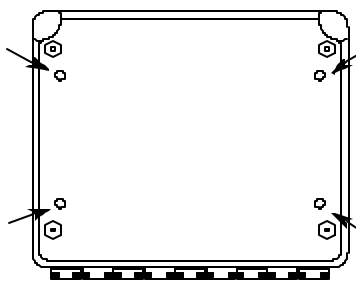

Diagram #2



Diagram #3

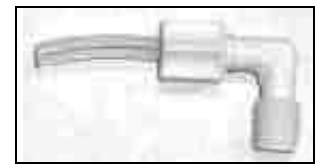

Diagram #4

## SECTION 2: INSTALLATION/OPERATION INSTRUCTIONS

### CHEMICAL DISPENSING EQUIPMENT HT-1 & HT-2

#### TO PREPARE PUMPS FOR OPERATION

The HT-1 is a chemical dispensing unit supplied with a detergent pump. Locate the open end of the chemical tube with the tube stiffener and place in the appropriate container.

The HT-2 is a chemical dispensing unit supplied with detergent and rinse additive pumps. Locate the open ends of the chemical tubes with the tube stiffeners and place each one in the appropriate container.

- A. Red Tubing = Detergent
- B. Blue Tubing (HT-2 Only) = Rinse Aid

#### PRIMING CHEMICAL FEEDER PUMPS

Chemical feeder pumps need priming when the machine is first installed or if for some reason the chemical lines have been removed and air has been allowed to enter.

**CAUTION: Water must be in the sump and wash tank prior to the dispensing of the chemical.**

1. Verify that the chemical tube stiffener inlet is in the detergent container.
2. Use the toggle switches on the front of the dispenser box to prime each pump. There is one (1) switch mounted above each peristaltic pump. One will prime the detergent pump, and the second will prime the rinse aid pump (HT-2 Only).
3. To prime the pump, hold the switch in the momentary position until chemical can be observed entering the tub.
4. Detergent is dispensed as required during the wash cycle by the cam timer. The amount of detergent may need to be increased or decreased depending on water quality and type of detergent. It is adjusted by changing Cam 6 on the cam timer.
5. Rinse additive is dispensed as required into the final rinse. The amount of rinse aid may need to be adjusted depending on water hardness and results. It can be changed by changing Cam 5 on the cam timer.



**WARNING: Some of the chemicals used in dishwashing may cause chemical burns if they come on contact with your skin. Wear appropriate protective gear when handling these chemicals. If you do come in contact with these chemicals flush the area with fresh water.**

---

**CHEMICAL DISPENSING EQUIPMENT LT-1 & LT-3**

**TO PREPARE PUMPS FOR OPERATION**

The LT-1 is a chemical dispensing unit supplied with a sanitizer chemical pump. Locate the open end of the chemical tube with the tube stiffener and place in the appropriate container.

The LT-3 is a chemical dispensing unit supplied with detergent, rinse additive, and sanitizer chemical pumps. Locate the open ends of the chemical tubes with the tube stiffeners and place each one in the appropriate container.

- A. Red Tubing = Detergent
- B. Blue Tubing (LT-3 Only) = Rinse Aid
- C. White Tubing (LT-3 Only) = Sanitizer

**PRIMING CHEMICAL FEEDER PUMPS**

Chemical feeder pumps need priming when the machine is first installed or if for some reason the chemical lines have been removed and air has been allowed to enter.

**CAUTION: Water must be in the sump and wash tank prior to the dispensing of the chemical.**

1. Verify that the proper chemical tube stiffener inlet is in the proper container.
2. Use the toggle switches on the front of the dispenser box to prime each pump. There is one (1) switch mounted above each peristaltic pump. One will prime the detergent pump, and the second will prime either the rinse aid pump.
3. To prime the pumps, hold the switch in the momentary position until chemical can be observed entering the tub.
4. Sanitizer, either chlorine or iodine, is dispensed into the final rinse. The amount of sanitizer may need to be adjusted depending on the concentration and type of sanitizer used. It is adjusted by changing Cam 6 on the cam timer.
5. Detergent is dispensed as required during the wash cycle by the cam timer. The amount of detergent may need to be increased or decreased depending on water quality and type of detergent. It is adjusted by changing Cam 7 on the cam timer.
6. Rinse additive is dispensed as required into the final rinse. The amount of rinse aid may need to be adjusted depending on water hardness and results. It can be changed by changing Cam 8 on the cam timer.



**WARNING: Some of the chemicals used in dishwashing may cause chemical burns if they come on contact with your skin. Wear appropriate protective gear when handling these chemicals. If you do come in contact with these chemicals flush the area with fresh water.**

## SECTION 2: INSTALLATION/OPERATION INSTRUCTIONS

### CAM TIMER OPERATION FOR HT-1

The cam timer is a 2 minute 6 cam timer with an OFF-DRAIN function.

The following is a description of set points for each cam and function for each switch.

**CAM 1:** Cam 1 is a cut cam with a single notch and serves as the Cycle/Reset.

**FUNCTION:** When the machine is in the operation mode the notch is the home position. The machine will set idle until the door is opened, then cam 1 moves to the start position and holds until the door is closed. The closing of the door will start the next cycle. The cam will rotate a complete cycle and back to the home position and hold.

**CAM 2:** Cam 2 is a cut cam and provides the off/drain function.

**FUNCTION:** The function of the off/drain cam is controlled by the power switch. When the power switch is in the ON position the off/drain function is disabled. To use the off/drain, start a cycle and place the power switch in the OFF position. The machine will run a wash cycle, drain and stop. The machine will hold this state of operation until the power switch is turned on, when turned on the machine will fill, run a rinse cycle and stop at the home position.

The off/drain cam works off the normally open contacts of cam 2. This requires the switch to be held closed by the cam. The off/drain cam switch will pick up just after the cycle cam switch and drop back down just after the wash cycle cam switch.

**CAM 3:** Cam 3 is a cut cam and controls the wash and rinse cycles.

**FUNCTION:** The wash and rinse cam works off the normally open contacts of cam 3. This requires the switch to be held closed by the cam. The wash/rinse cam switch will pick up just after the cycle cam switch and drop back down just before the off/drain cycle cam switch. Wash pump will run approximately 58 seconds. The machine will drain and fill. The rinse cycle will start after the fill, approximately at the 82 second mark and will last 35 seconds. The machine will then return to the home position.

**NOTE:** The last 3 cams are adjustable. The following instructions will require that the timer position have the cams to the front and the motor to the left.

**CAM 4:** Cam 4 is an adjustable cam and controls the drain valve.

**FUNCTION:** The drain valve cam works off the normally closed contacts of cam 4. This requires the switch to be held open by the cam and allowed to drop into the notch to operate the drain valve. The pumped drain and fill cams require adjustment due to varying water pressure. The drain must be adjusted to remove whatever water the fill brings into the machine.

**SETTINGS:** The right side of cam 4 must be set to pick up the switch arm just before the wash cycle cam switch drops. If the drain valve does not close first the water in the drain hose will back up into the pump housing and wash tank.

Any adjustment made to the drain should be made with the left side of cam 4. The adjustment must be moved back into the wash time until all water is drained from the wash tank.

**CAM 5:** Cam 5 is an adjustable cam and controls the fill valve.

**FUNCTION:** The fill valve cam works off the normally closed contacts of cam 5. This requires the switch to be held open by the cam and allowed to drop into the notch to operate the fill valve. The pumped drain and fill cams require adjustment due to varying water pressure. Cam 5 must be adjusted to fill the wash tank to the proper operating water level. (Remember, the drain cycle must remove what the fill cycle brings in.)

**SETTINGS:** The left side of cam 5 must be set to drop in just past the stop point of the off/drain cam. There must be a dwell between the off/drain and the fill, so that the fill will not run while the machine is in the off state.

Any adjustment made to the fill should be made with the right side of cam 5. Proper water level will be achieved when the water touches the bottom of the strainer pan.



**CAM TIMER OPERATION FOR HT-1 (CONTINUED)**

CAM 6: Cam 6 is an adjustable cam and controls the detergent pump.

FUNCTION: The detergent pump cam works off the normally closed contacts of cam 6. This requires the switch to be held open by the cam and allowed to drop into the notch to operate the pump.

SETTINGS: The left side of cam 6 must be set to drop in just past the starting point of the wash cam. The adjustment for detergent volume must be made with the right side of the cam.

## SECTION 2: INSTALLATION/OPERATION INSTRUCTIONS

### CAM TIMER OPERATION FOR HT-2

The cam timer is a 2 minute 6 cam timer with an OFF-DRAIN function.

The following is a description of set points for each cam and function for each switch.

**CAM 1:** Cam 1 is a cut cam with a single notch and serves as the Cycle/Reset.

**FUNCTION:** When the machine is in the operation mode the notch is the home position. The machine will set idle until the door is opened, then cam 1 moves to the start position and holds until the door is closed. The closing of the door will start the next cycle. The cam will rotate a complete cycle and back to the home position and hold.

**CAM 2:** Cam 2 is a cut cam and provides the off/drain function.

**FUNCTION:** The function of the off/drain cam is controlled by the power switch. When the power switch is in the ON position the off/drain function is disabled. To use the off/drain, start a cycle and place the power switch in the OFF position. The machine will run a wash cycle, drain and stop. The machine will hold this state of operation until the power switch is turned on, when turned on the machine will fill, run a rinse cycle and stop at the home position.

The off/drain cam works off the normally open contacts of cam 2. This requires the switch to be held closed by the cam. The off/drain cam switch will pick up just after the cycle cam switch and drop back down just after the wash cycle cam switch.

**CAM 3:** Cam 3 is a cut cam and controls the wash and rinse cycles.

**FUNCTION:** The wash and rinse cam works off the normally open contacts of cam 3. This requires the switch to be held closed by the cam. The wash/rinse cam switch will pick up just after the cycle cam switch and drop back down just before the off/drain cycle cam switch. Wash pump will run approximately 58 seconds. The machine will drain and fill. The rinse cycle will start after the fill, approximately at the 82 second mark and will last 35 seconds. The machine will then return to the home position.

**NOTE:** The last 3 cams are adjustable. The following instructions will require that the timer position have the cams to the front and the motor to the left.

**CAM 4:** Cam 4 is an adjustable cam and controls the drain valve.

**FUNCTION:** The drain valve cam works off the normally closed contacts of cam 4. This requires the switch to be held open by the cam and allowed to drop into the notch to operate the drain valve. The pumped drain and fill cams require adjustment due to varying water pressure. The drain must be adjusted to remove whatever water the fill brings into the machine.

**SETTINGS:** The right side of cam 4 must be set to pick up the switch arm just before the wash cycle cam switch drops. If the drain valve does not close first the water in the drain hose will back up into the pump housing and wash tank.

Any adjustment made to the drain should be made with the left side of cam 4. The adjustment must be moved back into the wash time until all water is drained from the wash tank.

**CAM 5:** Cam 5 is an adjustable cam and controls the fill valve.

**FUNCTION:** The fill valve cam works off the normally closed contacts of cam 5. This requires the switch to be held open by the cam and allowed to drop into the notch to operate the fill valve. The pumped drain and fill cams require adjustment due to varying water pressure. Cam 5 must be adjusted to fill the wash tank to the proper operating water level. (Remember, the drain cycle must remove what the fill cycle brings in.)

**SETTINGS:** The left side of cam 5 must be set to drop in just past the stop point of the off/drain cam. There must be a dwell between the off/drain and the fill, so that the fill will not run while the machine is in the off state.

Any adjustment made to the fill should be made with the right side of cam 5. Proper water level will be achieved when the water touches the bottom of the strainer pan.

**CAM 5:** Cam 5 is an adjustable cam and also controls the rinse aid pump.

## SECTION 2: INSTALLATION/OPERATION INSTRUCTIONS

---

### CAM TIMER OPERATION FOR HT-2 (CONTINUED)

**FUNCTION:** The rinse aid pump cam works off the normally closed contacts of cam 5. This requires the switch to be held open by the cam and allowed to drop into the notch to operate the pump.

**SETTINGS:** The left side of cam 5 must be set to drop in just past the starting point of the fill cam. The adjustment for rinse aid volume must be made with the right side of the cam.

**CAM 6:** Cam 6 is an adjustable cam and controls the detergent pump.

**FUNCTION:** The detergent pump cam works off the normally closed contacts of cam 6. This requires the switch to be held open by the cam and allowed to drop into the notch to operate the pump.

**SETTINGS:** The left side of cam 6 must be set to drop in just past the starting point of the wash cam. The adjustment for detergent volume must be made with the right side of the cam.

## SECTION 2: INSTALLATION/OPERATION INSTRUCTIONS

### CAM TIMER OPERATION FOR LT-1

The cam timer is a 2 minute 8 cam timer with an OFF-DRAIN function.

The following is a description of set points for each cam and function for each switch.

**CAM 1:** Cam 1 is a cut cam with a single notch and serves as the Cycle/Reset.

**FUNCTION:** When the machine is in the operation mode the notch is the home position. The machine will set idle until the door is opened, then cam 1 moves to the start position and holds until the door is closed. The closing of the door will start the next cycle. The cam will rotate a complete cycle and back to the home position and hold.

**CAM 2:** Cam 2 is a cut cam and provides the off/drain function.

**FUNCTION:** The function of the off/drain cam is controlled by the power switch. When the power switch is in the ON position the off/drain function is disabled. To use the off/drain, start a cycle and place the power switch in the OFF position. The machine will run a wash cycle, drain and stop. The machine will hold this state of operation until the power switch is turned on, when turned on the machine will fill, run a rinse cycle and stop at the home position.

The off/drain cam works off the normally open contacts of cam 2. This requires the switch to be held closed by the cam. The off/drain cam switch will pick up just after the cycle cam switch and drop back down just after the wash cycle cam switch.

**CAM 3:** Cam 3 is a cut cam and controls the wash and rinse cycles.

**FUNCTION:** The wash and rinse cam works off the normally open contacts of cam 3. This requires the switch to be held closed by the cam. The wash/rinse cam switch will pick up just after the cycle cam switch and drop back down just before the off/drain cycle cam switch. Wash pump will run approximately 58 seconds. The machine will drain and fill. The rinse cycle will start after the fill, approximately at the 82 second mark and will last 35 seconds. The machine will then return to the home position.

**NOTE:** The last 3 cams are adjustable. The following instructions will require that the timer position have the cams to the front and the motor to the left.

**CAM 4:** Cam 4 is an adjustable cam and controls the drain valve.

**FUNCTION:** The drain valve cam works off the normally closed contacts of cam 4. This requires the switch to be held open by the cam and allowed to drop into the notch to operate the drain valve. The pumped drain and fill cams require adjustment due to varying water pressure. The drain must be adjusted to remove whatever water the fill brings into the machine.

**SETTINGS:** The right side of cam 4 must be set to pick up the switch arm just before the wash cycle cam switch drops. If the drain valve does not close first the water in the drain hose will back up into the pump housing and wash tank.

Any adjustment made to the drain should be made with the left side of cam 4. The adjustment must be moved back into the wash time until all water is drained from the wash tank.

**CAM 5:** Cam 5 is an adjustable cam and controls the fill valve.

**FUNCTION:** The fill valve cam works off the normally closed contacts of cam 5. This requires the switch to be held open by the cam and allowed to drop into the notch to operate the fill valve. The pumped drain and fill cams require adjustment due to varying water pressure. Cam 5 must be adjusted to fill the wash tank to the proper operating water level. (Remember, the drain cycle must remove what the fill cycle brings in.)

**SETTINGS:** The left side of cam 5 must be set to drop in just past the stop point of the off/drain cam. There must be a dwell between the off/drain and the fill, so that the fill will not run while the machine is in the off state.

Any adjustment made to the fill should be made with the right side of cam 5. Proper water level will be achieved when the water touches the bottom of the strainer pan.

**CAM TIMER OPERATION FOR LT-1 (CONTINUED)**

**CAM 6:** Cam 6 is an adjustable cam and controls the sanitizer pump.

**FUNCTION:** The sanitizer pump cam works off the normally closed contacts of cam 6. This requires the switch to be held open by the cam and allowed to drop into the notch to operate the pump.

**SETTINGS:** The left side of cam 6 must be set to drop in just past the starting point of the wash cam. The adjustment for sanitizer volume must be made with the right side of the cam.

**CAM 7:** Cam 7 is an adjustable cam and controls the detergent pump.

**FUNCTION:** The detergent pump cam works off the normally closed contacts of cam 7. This requires the switch to be held open by the cam and allowed to drop into the notch to operate the pump.

**SETTINGS:** The left side of cam 7 must be set to drop in just past the starting point of the wash cam. The adjustment for detergent volume must be made with the right side of the cam.

**CAM 8:** Cam 8 is an adjustable cam and controls the rinse aid pump.

**FUNCTION:** The rinse aid pump cam works off the normally closed contacts of cam 8. This requires the switch to be held open by the cam and allowed to drop into the notch to operate the pump.

**SETTINGS:** The left side of cam 8 must be set to drop in just past the starting point of the wash cam. The adjustment for rinse aid volume must be made with the right side of the cam.

## SECTION 2: INSTALLATION/OPERATION INSTRUCTIONS

### CAM TIMER OPERATION FOR LT-3

The cam timer is a 2 minute 6 cam timer with an OFF-DRAIN function.

The following is a description of set points for each cam and function for each switch.

**CAM 1:** Cam 1 is a cut cam with a single notch and serves as the Cycle/Reset.

**FUNCTION:** When the machine is in the operation mode the notch is the home position. The machine will set idle until the door is opened, then cam 1 moves to the start position and holds until the door is closed. The closing of the door will start the next cycle. The cam will rotate a complete cycle and back to the home position and hold.

**CAM 2:** Cam 2 is a cut cam and provides the off/drain function.

**FUNCTION:** The function of the off/drain cam is controlled by the power switch. When the power switch is in the ON position the off/drain function is disabled. To use the off/drain, start a cycle and place the power switch in the OFF position. The machine will run a wash cycle, drain and stop. The machine will hold this state of operation until the power switch is turned on, when turned on the machine will fill, run a rinse cycle and stop at the home position.

The off/drain cam works off the normally open contacts of cam 2. This requires the switch to be held closed by the cam. The off/drain cam switch will pick up just after the cycle cam switch and drop back down just after the wash cycle cam switch.

**CAM 3:** Cam 3 is a cut cam and controls the wash and rinse cycles.

**FUNCTION:** The wash and rinse cam works off the normally open contacts of cam 3. This requires the switch to be held closed by the cam. The wash/rinse cam switch will pick up just after the cycle cam switch and drop back down just before the off/drain cycle cam switch. Wash pump will run approximately 58 seconds. The machine will drain and fill. The rinse cycle will start after the fill, approximately at the 82 second mark and will last 35 seconds. The machine will then return to the home position.

**NOTE:** The last 3 cams are adjustable. The following instructions will require that the timer position have the cams to the front and the motor to the left.

**CAM 4:** Cam 4 is an adjustable cam and controls the drain valve.

**FUNCTION:** The drain valve cam works off the normally closed contacts of cam 4. This requires the switch to be held open by the cam and allowed to drop into the notch to operate the drain valve. The pumped drain and fill cams require adjustment due to varying water pressure. The drain must be adjusted to remove whatever water the fill brings into the machine.

**SETTINGS:** The right side of cam 4 must be set to pick up the switch arm just before the wash cycle cam switch drops. If the drain valve does not close first the water in the drain hose will back up into the pump housing and wash tank.

Any adjustment made to the drain should be made with the left side of cam 4. The adjustment must be moved back into the wash time until all water is drained from the wash tank.

**CAM 5:** Cam 5 is an adjustable cam and controls the fill valve.

**FUNCTION:** The fill valve cam works off the normally closed contacts of cam 5. This requires the switch to be held open by the cam and allowed to drop into the notch to operate the fill valve. The pumped drain and fill cams require adjustment due to varying water pressure. Cam 5 must be adjusted to fill the wash tank to the proper operating water level. (Remember, the drain cycle must remove what the fill cycle brings in.)

**SETTINGS:** The left side of cam 5 must be set to drop in just past the stop point of the off/drain cam. There must be a dwell between the off/drain and the fill, so that the fill will not run while the machine is in the off state.

Any adjustment made to the fill should be made with the right side of cam 5. Proper water level will be achieved when the water touches the bottom of the strainer pan.

**CAM TIMER OPERATION FOR LT-3 (CONTINUED)**

**CAM 6:** Cam 6 is an adjustable cam and controls the sanitizer pump.

**FUNCTION:** The sanitizer pump cam works off the normally closed contacts of cam 6. This requires the switch to be held open by the cam and allowed to drop into the notch to operate the pump.

**SETTINGS:** The left side of cam 6 must be set to drop in just past the starting point of the wash cam. The adjustment for sanitizer volume must be made with the right side of the cam.

**CAM 7:** Cam 7 is an adjustable cam and controls the detergent pump.

**FUNCTION:** The detergent pump cam works off the normally closed contacts of cam 7. This requires the switch to be held open by the cam and allowed to drop into the notch to operate the pump.

**SETTINGS:** The left side of cam 7 must be set to drop in just past the starting point of the wash cam. The adjustment for detergent volume must be made with the right side of the cam.

**CAM 8:** Cam 8 is an adjustable cam and controls the rinse aid pump.

**FUNCTION:** The rinse aid pump cam works off the normally closed contacts of cam 8. This requires the switch to be held open by the cam and allowed to drop into the notch to operate the pump.

**SETTINGS:** The left side of cam 8 must be set to drop in just past the starting point of the wash cam. The adjustment for rinse aid volume must be made with the right side of the cam.

---

## **SECTION 3: PARTS SECTION**



HT-1 ASSEMBLY

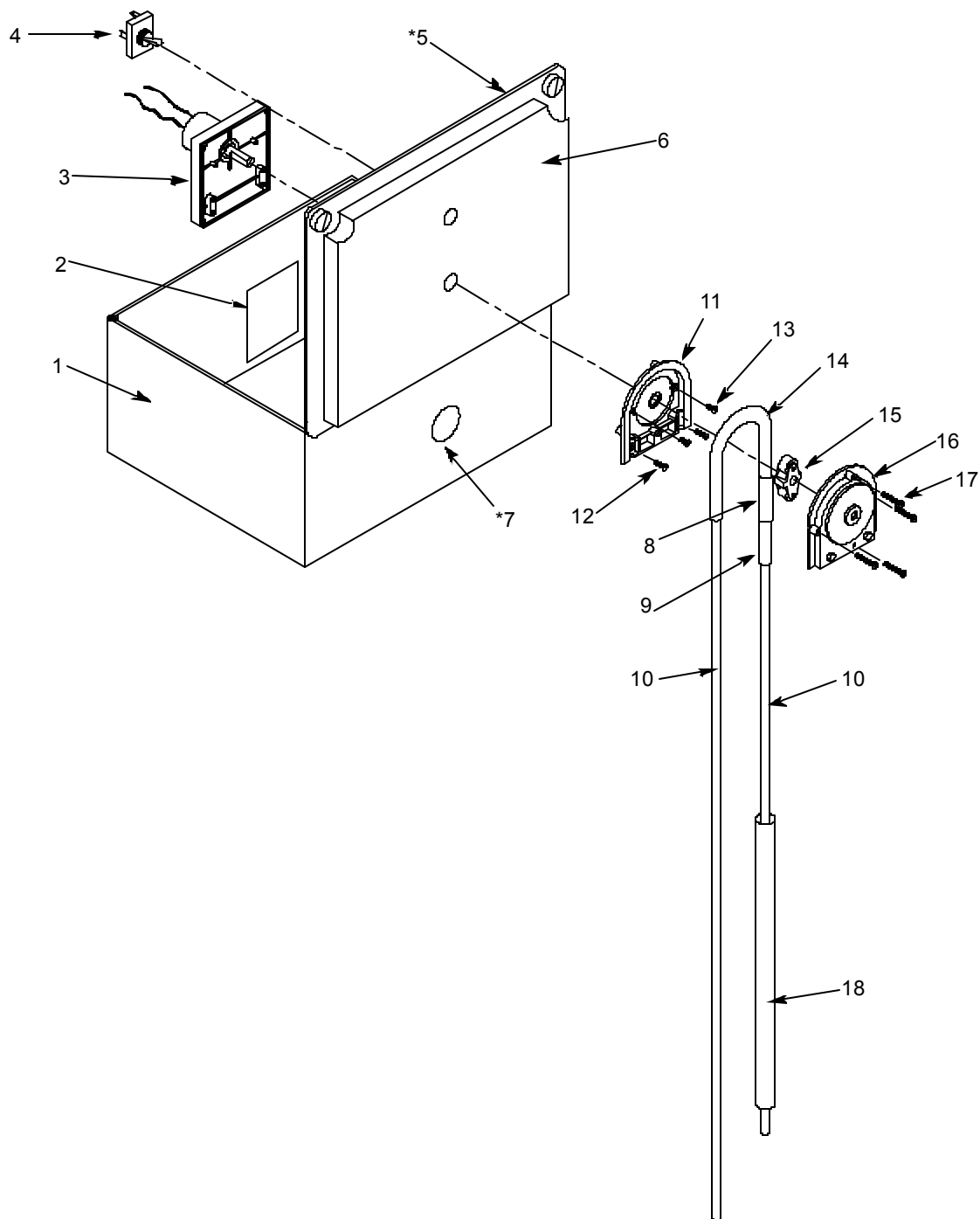

**SECTION 3: PARTS SECTION****HT-1 ASSEMBLY (CONTINUED)**

<b>ITEM</b>	<b>QTY</b>	<b>DESCRIPTION</b>	<b>Mfg. No.</b>
	1	Complete HT-1 Assembly	5700-002-51-98
1	1	Box, Fiberglass Single Chemical Feeder Pump	5700-031-73-03
2	1	Decal, Warning - Disconnect Power	9905-100-75-93
3	1	Chemical Feeder Pump Motor, 240V, 36 RPM	4320-111-47-47
4	1	Switch, SPST OFF/ON	5930-111-38-21
5	1	Decal, Electrical Schematic	9905-002-51-94
6	1	Decal, HT-1	9905-002-51-97
7	1	Conduit Fitting, 1/2" 90° Plastic	5975-011-45-14
8	1	Tubing, 5/16" ID x 7/16" OD Clear	4720-111-35-34
9	1	Tubing, 3/16" ID x 3/8" OD x 1.6" Long	5700-111-35-33
10	2	Tubing, Plastic 1/4" OD Red	4720-601-12-00
	1	Chemical Feeder Pump Assembly, 36 RPM	4320-121-37-10
11	1	Housing, Rear Assy	4320-111-37-09
12	2	Screw, 8-32 x 1/2" Phillips Flat Head	5305-011-37-06
13	2	Screw, 8-32 x 3/8" Phillips Flat Head	5305-011-37-07
14	1	Squeeze Tube	5700-111-35-29
15	1	Anko Roller	4320-111-36-70
16	1	Housing, Front	4320-111-37-08
17	4	Screw, 6-32 x 3/4" Phillips Pan Head	5305-011-37-05
18	2	Stiffener, Tube	5700-002-66-49

HT-2 ASSEMBLY

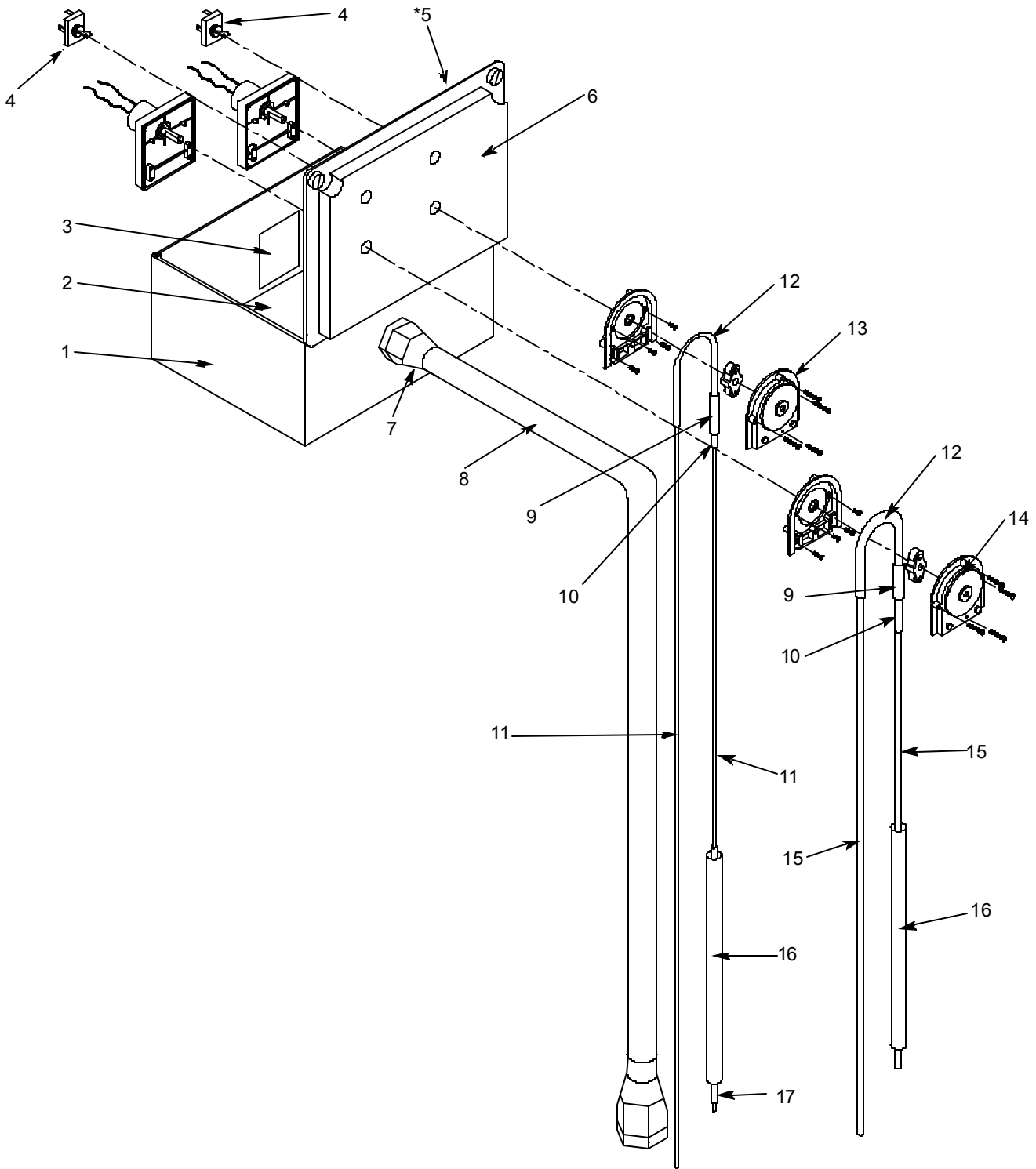

**SECTION 3: PARTS SECTION****HT-2 ASSEMBLY (CONTINUED)**

<b>ITEM</b>	<b>QTY</b>	<b>DESCRIPTION</b>	<b>Mfg. No.</b>
	1	Complete HT-2 Assembly, 240V	5700-031-75-62
	1	Complete HT-2 Assembly, 115V	5700-002-84-70
1	1	Box, Fiberglass Double Chemical Feeder Pump	5700-031-73-02
2	1	Inner Panel Assembly, 240V	5700-002-10-21
2	1	Inner Panel Assembly, 115V	5700-002-84-71
3	1	Decal, Warning	9905-100-75-93
4	2	Switch, OFF/ON Toggle	5930-111-20-18
5	1	Decal, Electrical Schematic	9905-011-74-58
6	1	Decal, HT-2	9905-021-76-59
7	2	Conduit Fitting, 1/2" Straight	5975-011-45-13
8	1	Conduit, 1/2" x 6' Long	5700-002-92-41
9	2	Tubing, Santoprene 3/8" OD x 3" Long	5700-011-85-73
10	2	Tubing, Santoprene 3/8" OD x 8" Long	5700-111-35-29
11	2	Tubing, Polyethylene, White 1/8" x 120" Long	5700-002-76-14
12	2	Tubing, Tygon Clear 7/16" OD x 1.93" Long	5700-011-85-72
13	1	Chemical Feeder Pump Assembly, 240V, 14 RPM	5700-031-63-34
14	1	Chemical Feeder Pump Assembly, 240V, 14 RPM	5700-031-65-20
15	2	Tubing, Polyethylene, Red 1/4" x 120" Long	5700-011-85-68
16	2	Stiffener, Tube	5700-002-66-49
17	1	Tubing, Polyethylene, Blue 1/4" x 22" Long	5700-011-86-78
*18	1	Bulk Head Plug, Modified	5700-011-61-37

\* Represents an item not shown.

## HT-2 INNER PANEL ASSEMBLY

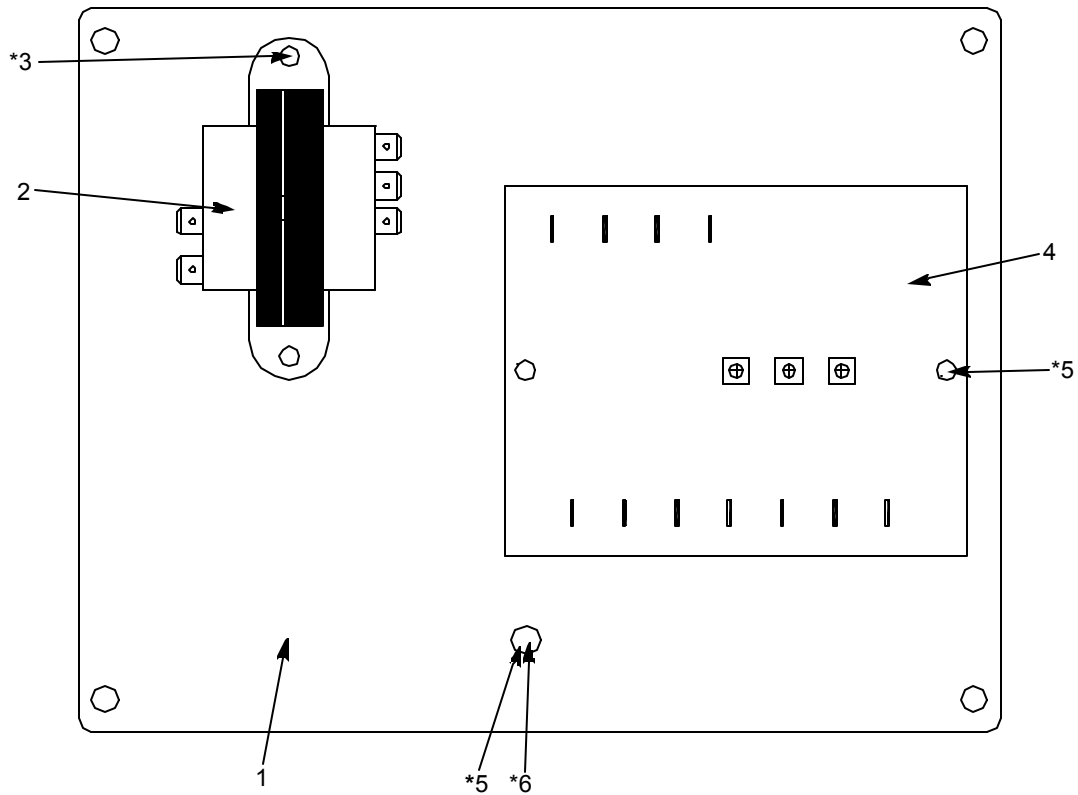

ITEM	QTY	DESCRIPTION	Mfg. No.
	1	Inner Panel Assembly, 240V	5700-002-10-21
	1	Inner Panel Assembly, 115V	5700-002-84-71
1	1	Panel	5700-021-74-54
2	1	Transformer, 20VA 208/240V - 24V	5950-011-61-67
2	1	Transformer, 115V - 24V	5950-002-16-78
3	3	Screw, 10-24 x 3/8" Phillips Truss Head	5305-173-03-00
4	1	Board, Speed Control	5945-011-46-24
5	2	Screw, 10-32 x 7/8" Fillister Head	5305-973-04-00
6	1	Star Washer, External Tooth #10	5311-273-02-00

\* Represents an item not shown.

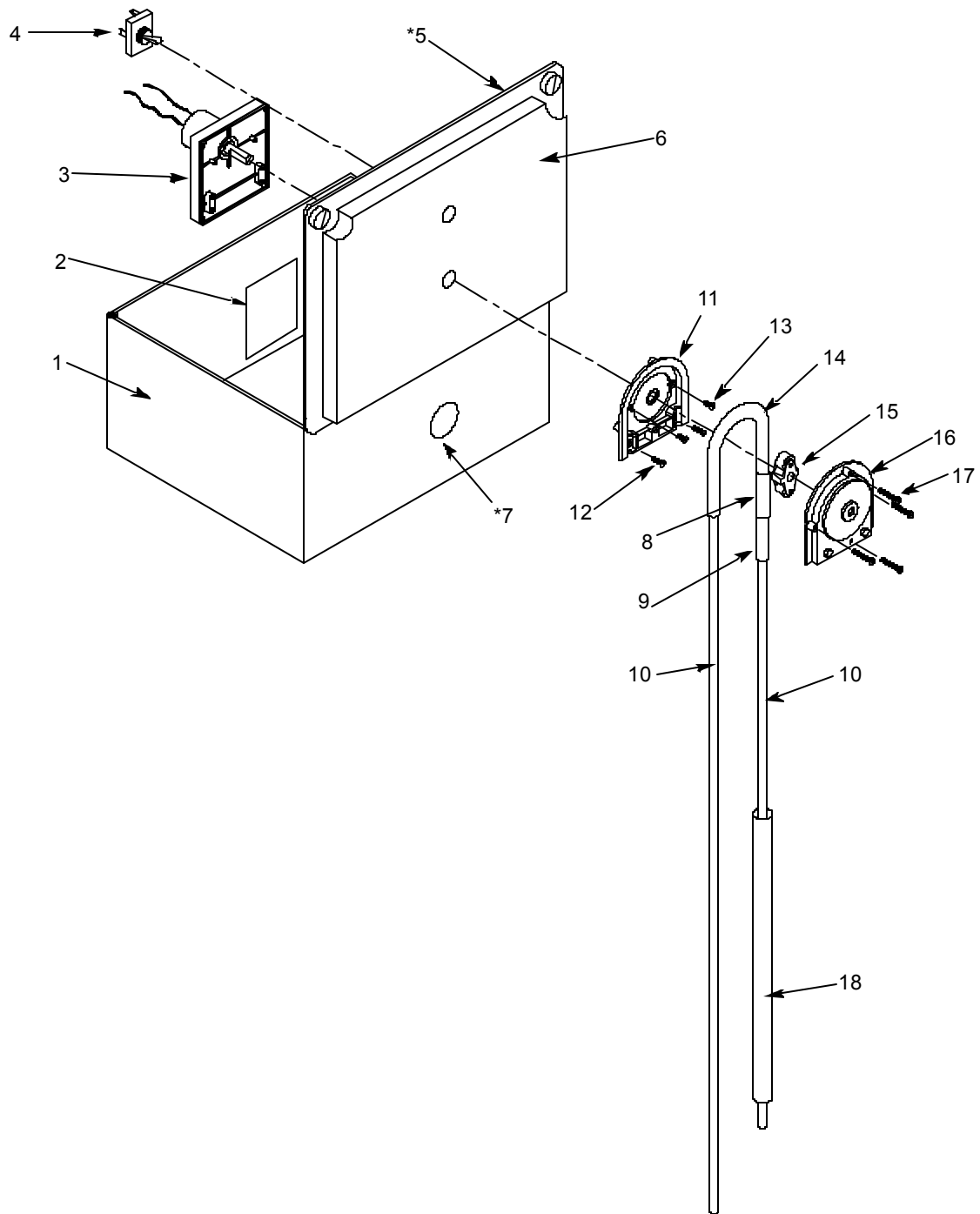

## LT-1 ASSEMBLY (CONTINUED)

ITEM	QTY	DESCRIPTION	Mfg. No.
	1	Complete LT-1 Assembly	5700-031-75-60
1	1	Box, Fiberglass Single Chemical Feeder Pump	5700-031-73-03
2	1	Decal, Warning - Disconnect Power	9905-100-75-93
3	1	Chemical Feeder Pump Motor, 115V, 36 RPM	4320-111-35-14
4	1	Switch, SPST OFF/ON	5930-111-38-21
5	1	Decal, Electrical Schematic	9905-011-74-22
6	1	Decal, LT-1	9905-021-76-57
7*	1	Conduit Fitting, 1/2" 90° Plastic	5975-011-45-14
8	.17 FT	Tubing, 5/16" ID x 7/16" OD Clear	4720-111-35-34
9	1	Tubing, 3/16" ID x 3/8" OD x 1.6" Long	5700-111-35-33
10	12 FT	Tubing, 1/4" OD Paraflex	4720-111-51-70
	1	Chemical Feeder Pump Assembly	4320-121-37-10
11	1	Housing, Rear Assy	4320-111-37-09
12	2	Screw, 8-32 x 1/2" Phillips Flat Head	5305-011-37-06
13	2	Screw, 8-32 x 3/8" Phillips Flat Head	5305-011-37-07
14	1	Chemical Feeder Pump Squeeze Tube	5700-111-35-29
15	1	Anko Roller	4320-111-36-70
16	1	Housing, Front	4320-111-37-08
17	4	Screw, 6-32 x 3/4" Phillips Pan Head	5305-011-37-05
18	1	Stiffener, Tube	5700-002-66-49





## LT-3 ASSEMBLY (CONTINUED)

ITEM	QTY	DESCRIPTION	Mfg. No.
	1	Complete LT-3 Assembly, 115V	5700-031-75-61
	1	Complete LT-3 Assembly, 240V	5700-002-37-80
1	1	Box, Fiberglass Triple Chemical Feeder Pump	5700-031-73-00
2	1	Decal, Warning	9905-100-75-93
3	3	Switch, OFF/ON Toggle	5930-111-38-21
4	1	Chemical Feeder Pump Motor, 115V, 14 RPM	4320-111-35-13
4	1	Chemical Feeder Pump Motor, 240V, 14 RPM	4320-111-47-46
5	2	Chemical Feeder Pump Motor, 115V, 36 RPM	4320-111-35-14
5	2	Chemical Feeder Pump Motor, 240V, 36 RPM	4320-111-47-47
6*	1	Decal, Electrical Schematic	9905-011-74-23
7	1	Decal, LT-3	9905-021-76-58
8	3	Chemical Feeder Pump Assembly,	4320-121-37-10
9	1	Housing, Rear Assy	4320-111-37-09
10	2	Screw, 8-32 x 1/2" Phillips Flat Head	5305-011-37-06
11	2	Screw, 8-32 x 3/8" Phillips Flat Head	5305-011-37-07
12	1	Squeeze Tube	5700-111-35-29
13	1	Anko Roller	4320-111-36-70
14	1	Housing, Front	4320-111-37-08
15	4	Screw, 6-32 x 3/4" Phillips Pan Head	5305-011-37-05
16	3	Tubing, Tygon Clear 5/16" ID x 7/16" OD x 1.93" Long	5700-011-85-72
17	2	Tubing, Santoprene 3/8" OD x 3" Long	5700-011-85-73
18	12 FT	Tubing, Plastic, 1/4" Blue	4720-601-11-00
19	3	Stiffener, Tube	5700-002-66-49
20	12 FT	Tubing, Parflex 1/4"	4720-111-51-70
21	1	Conduit, 1/2" x 6' Long	5700-011-85-71
22	2	Conduit Fitting, 1/2" Straight	5975-011-45-13
23	12 FT	Tubing, Plastic, 1/4" Red	4720-601-12-00
24*	1	Tube, 3/16" ID x 3/8" OD x 1.6" Long	5700-111-35-33
25*	1	Bulk Head Plug, Modified	5700-011-61-37

\* Represents an item not shown.

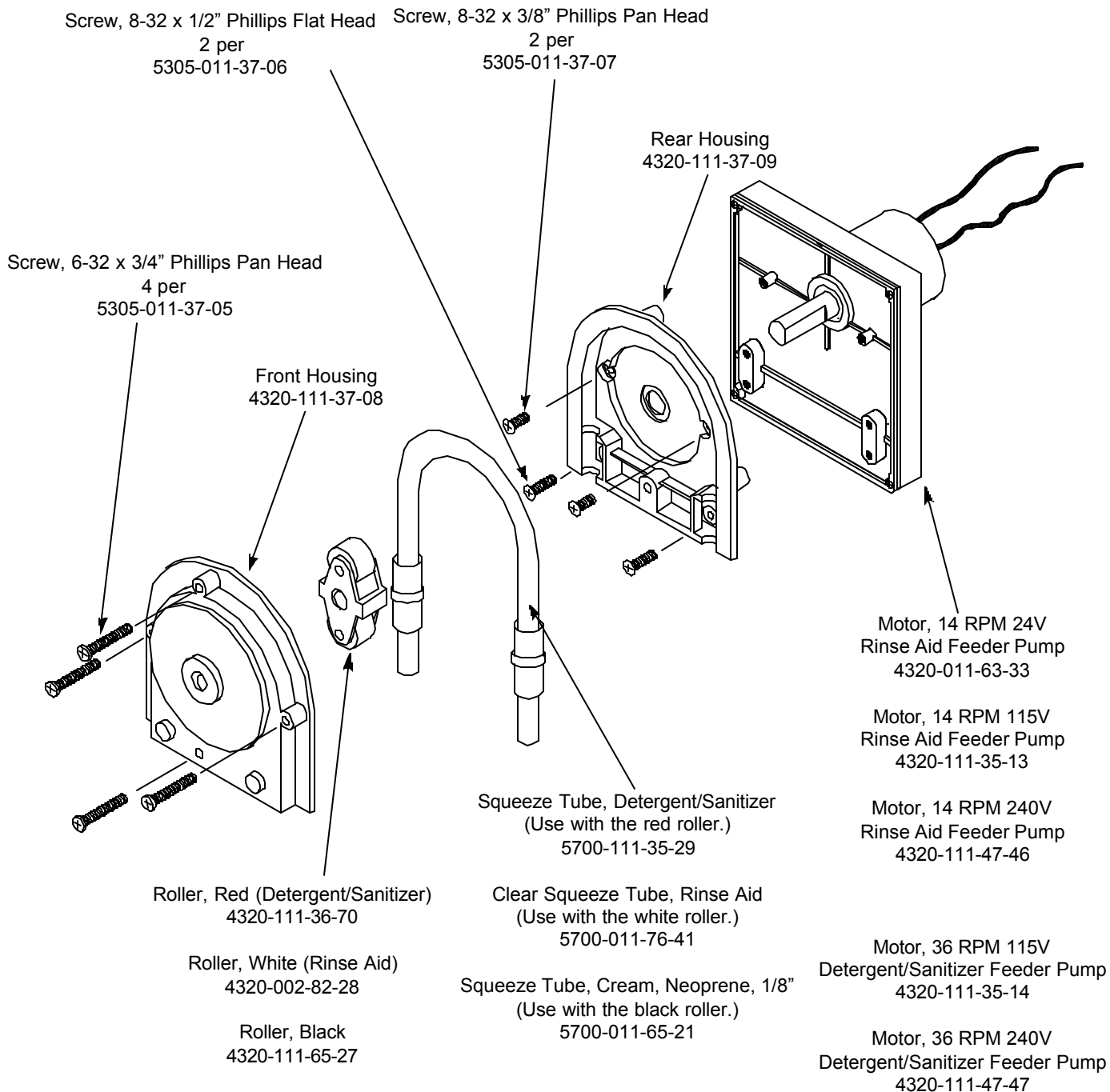

---

# **SECTION 4: ELECTRICAL SCHEMATICS**

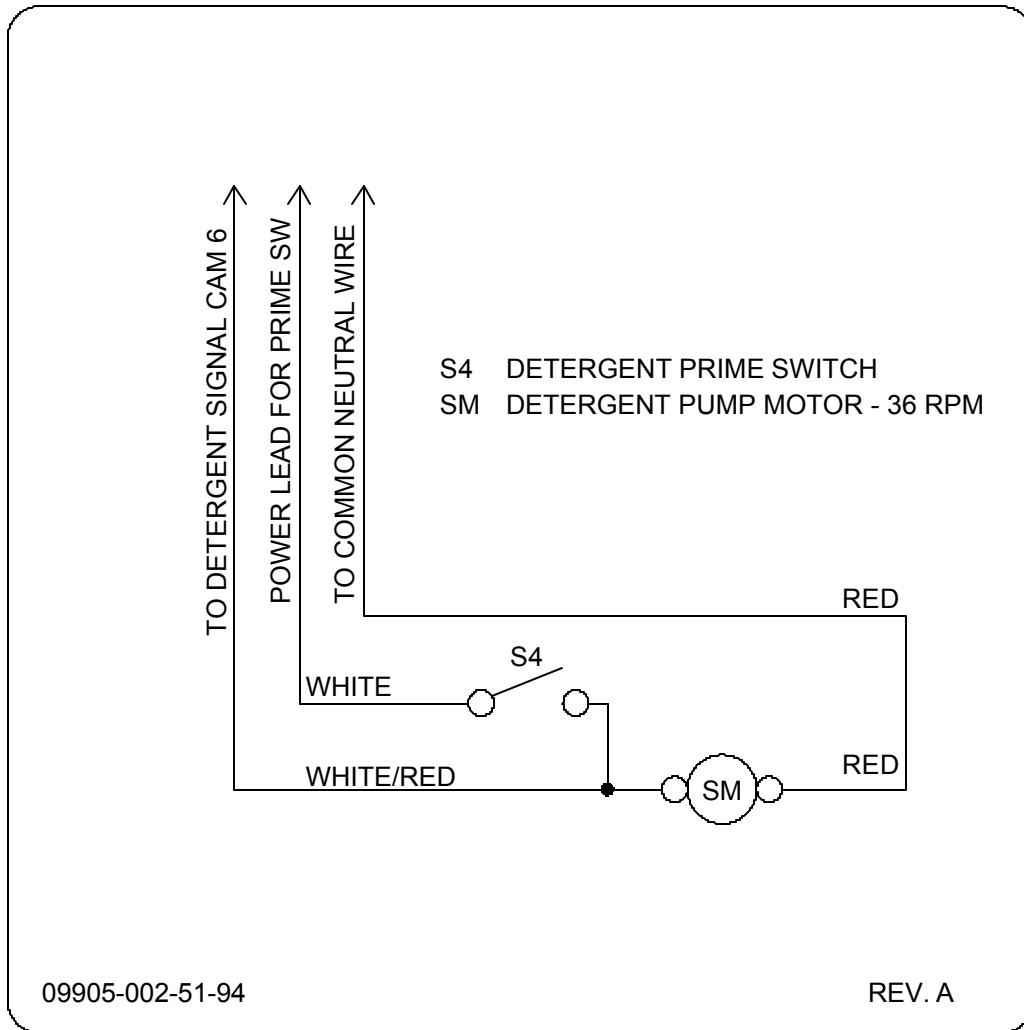

HT-2 115 VOLT, 60 HERTZ, SINGLE PHASE

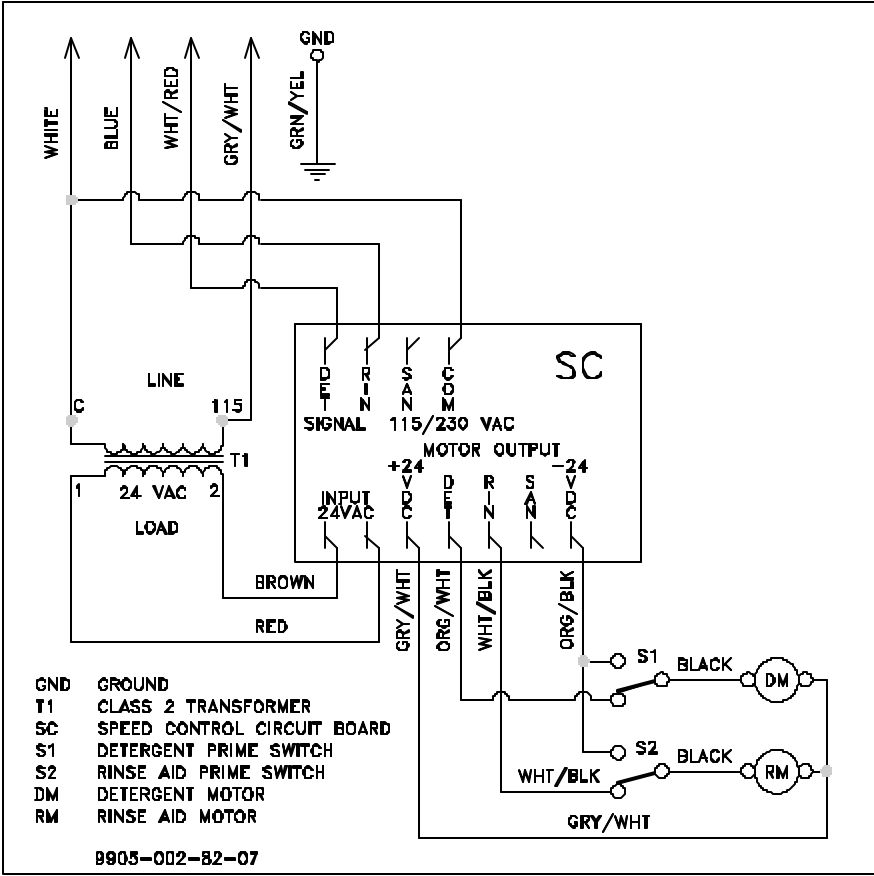

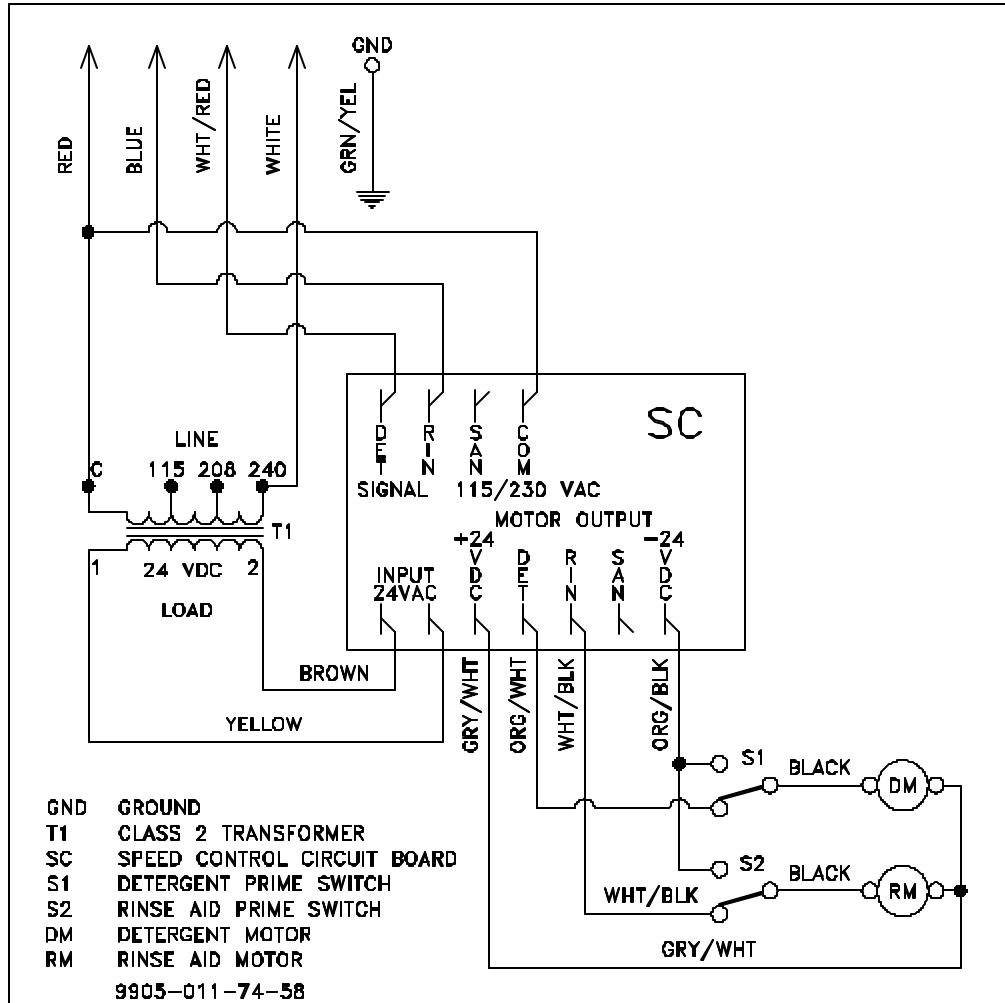

LT-1 115 VOLT, 60 HERTZ, SINGLE PHASE

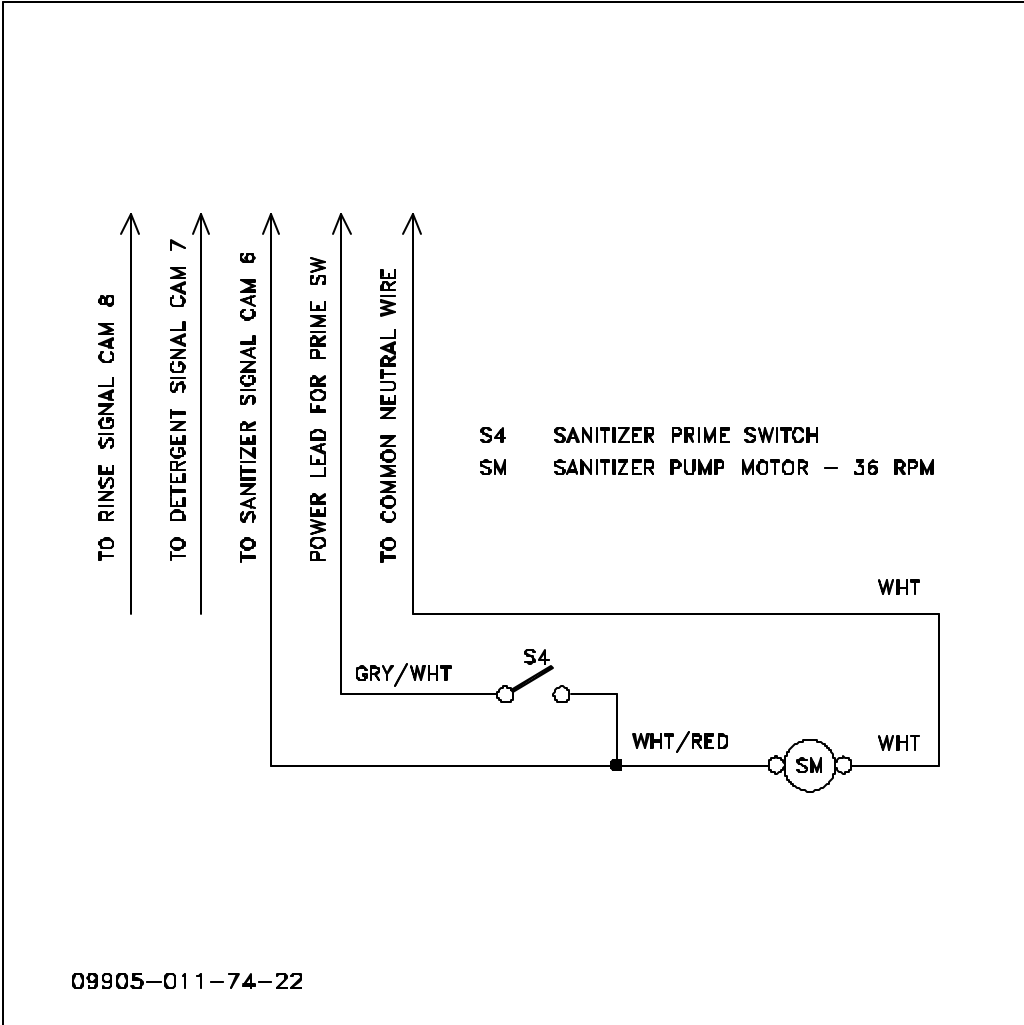

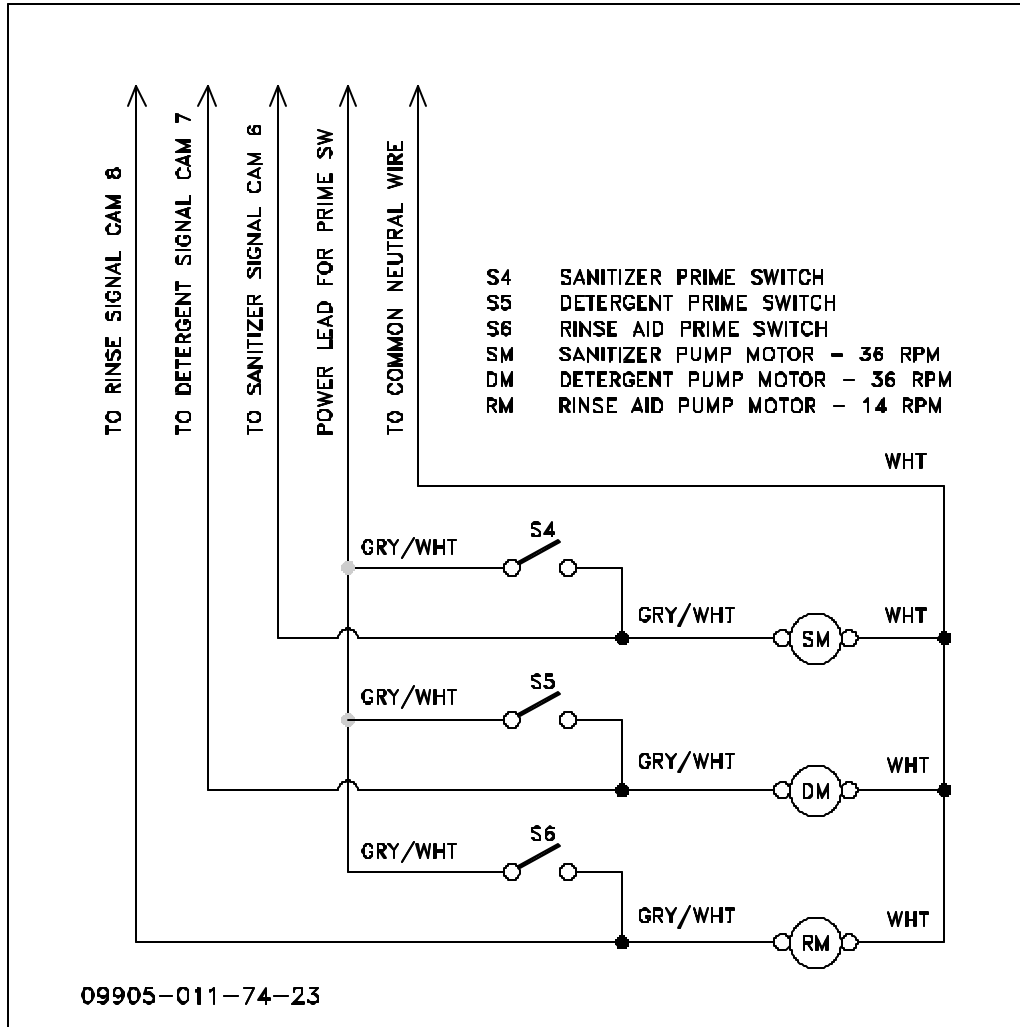



LT-3 240 VOLT, 60 HERTZ, SINGLE PHASE

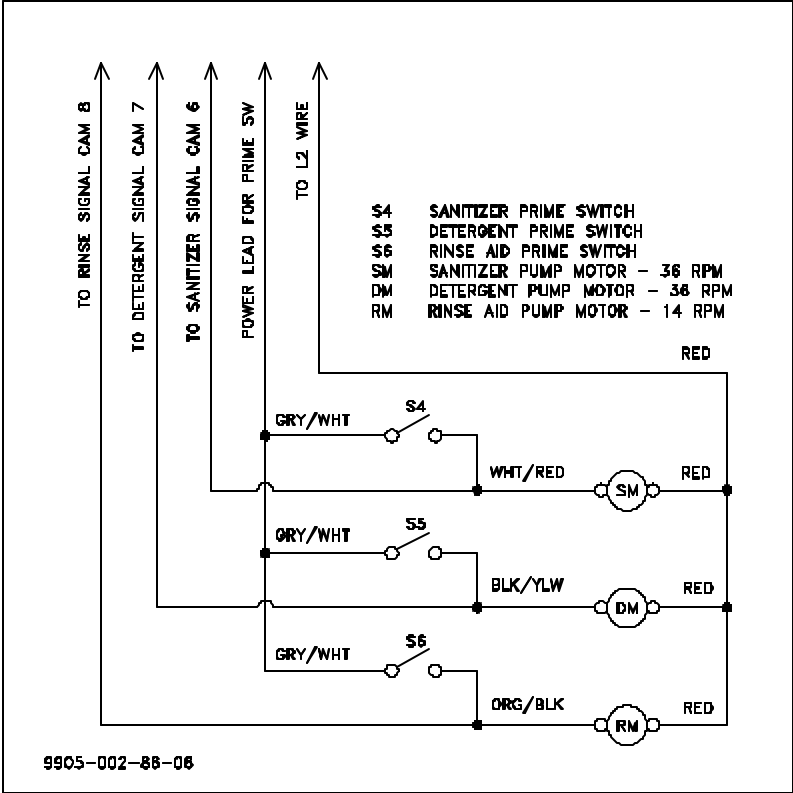

---

**SECTION 5:  
JACKSON MAINTENANCE &  
REPAIR CENTERS**

**SECTION 5: JACKSON MAINTENANCE & REPAIR CENTERS****ALABAMA TO HAWAII****ALABAMA:**

**JONES-McLEOD  
APPLIANCE SVC**  
1616 7TH AVE. NORTH  
BIRMINGHAM, AL 35203  
(205) 251-0159  
800-821-1150  
FAX: (205) 322-1440  
service@jones-mcleod.com

**JONES-McLEOD  
APPLIANCE SVC**  
854 LAKESIDE DRIVE  
MOBILE, AL 36693  
(334) 666-7278  
800-237-9859  
FAX: (334) 661-0223

**ALASKA:**

**RESTAURANT  
APPLIANCE SVC**  
7219 ROOSEVELT WAY NE  
SEATTLE, WA 98115  
(206) 524-8200  
800-433-9390  
FAX: (206) 525-2890  
info@restappl.com

**ARIZONA:**

**AUTHORIZED COMMERCIAL  
FOOD EQMT. SVC**  
4832 SOUTH 35TH STREET  
PHOENIX, AZ 85040  
(602) 234-2443  
800-824-8875  
FAX: (602) 232-5862  
acsboss@aol.com

**GCS SERVICE INC.**  
PHOENIX, AZ  
800-822-2303

**ARKANSAS:**

**BROMLEY PARTS & SVC**  
10TH AND RINGO  
P.O. BOX 1688  
LITTLE ROCK, AR 72202  
(501) 374-0281  
800-482-9269  
FAX: (501) 374-8352  
service@bromleyparts.com  
parts@bromleyparts.com

**COMMERCIAL PARTS & SVC.**  
3717 CHERRY ROAD  
MEMPHIS, TN 38118  
(901) 366-4587  
800-262-9155  
FAX: (901) 366-4588

**CALIFORNIA:**

**BARKERS FOOD  
MACHINERY SERVICES**  
5367 SECOND STREET  
IRWINDALE, CA 91706  
(626) 960-9390  
800-258-6999  
FAX: (626) 337-4541  
service@barkers.com

**GCS SERVICE INC.**  
LOS ANGELES, CA  
800-822-2303

**P & D APPLIANCE**  
4220-C ROSEVILLE ROAD  
NORTH HIGHLANDS, CA 95660  
(916) 974-2772  
800-824-7219  
FAX: (916) 974-2774

**INDUSTRIAL ELECTRIC SVC**  
5662 ENGINEER DRIVE  
HUNTINGON BEACH, CA 92649  
(714) 379-7100  
800-4573783  
FAX: (714) 379-7109

**GCS SERVICE INC.**  
360 LITTLEFIELD AVE  
S. SAN FRANCISCO, CA 94080  
(650) 635-0720  
800-969-4427  
FAX: (650) 871-4019

**BARKERS FOOD  
MACHINERY SERVICES**  
9373 ACTIVITY ROAD #G  
SAN DIEGO, CA 92126  
(858) 695-1091  
800-995-7955  
FAX: (858) 995-7955

**GCS SERVICE INC.**  
9030 KENMAR DR. SUITE 313  
SAN DIEGO, CA 92121  
(858) 549-8411  
800-422-7278  
FAX: (858) 549-2323

**P & D APPLIANCE SVC**  
100 SOUTH LINDEN AVE.  
S. SAN FRANCISCO, CA 94080  
(650) 635-1900  
800-424-1414  
FAX: (650) 635-1919  
pndappl@aol.com

**COLORADO:**

**HAWKINS COMMERCIAL  
APPLIANCE SERVICE**  
3000 S. WYANDOT ST.  
ENGLEWOOD, CO 80110  
(303) 781-5548  
(800) 624-2117  
FAX: (303) 761-8861

**COLORADO (cont.):**

**METRO APPLIANCE SERVICE**  
1640 S BROADWAY  
DENVER, CO 80210  
(303) 778-1126  
800-525-3532  
FAX: (303) 778-0268  
metroappls@aol.com

**CONNECTICUT:**

**GCS SERVICE INC.**  
302 MURPHY ROAD  
HARTFORD, CT 06114  
(860) 549-5575  
800-423-1562  
FAX: (860) 527-6355

**DELAWARE:**

**AMERICAN KITCHEN MACHIN-  
ERY & REPAIR**  
204 QUARRY STREET  
PHILADELPHIA, PA 19106  
(215) 627-7760  
800-848-7760  
FAX: (215) 627-1604

**GCS SERVICE INC.**  
817 N. THIRD STREET  
PHILADELPHIA, PA  
(215)925-6217  
800-441-9115  
FAX: (215) 925-6208

**ELMER SCHULTZ SERVICE**  
36 BELMONT AVE.  
WILLMINGTON, DE 19804  
(302) 655-8900  
800-225-0599  
FAX: (302) 656-3673  
elmer2@erols.com

**EMR SERVICE DIVISION**  
106 WILLIAMSPORT CIRCLE  
SALISBURY, MD 21804  
(410) 543-8197  
FAX: (410) 548-4038

**FLORIDA:**

**COMMERCIAL APPLIANCE SVC**  
8416 LAUREL FAIR CIRCLE  
BLDG 6, SUITE 114  
TAMPA, FL 33610  
(813) 663-0313  
800-282-4718  
FAX: (813) 663-0212  
commercialappliance@worldnet.at  
t.net

**FLORIDA (cont.):**

**GCS SERVICE INC**  
3373 N. W. 168TH STREET  
MIAMI, FL 33056  
(305) 621-6666  
800-766-8966  
FAX: (305) 621-6656

**GCS SERVICE INC**  
3902 CORPORES PARK DR.  
SUITE 350  
TAMPA, FL 33619  
(813) 626-6044  
800-282-3008  
FAX: (813) 621-1174

**JONES-McLEOD  
APPLIANCE SVC**  
854 LAKESIDE DRIVE  
MOBILE, AL 36693  
(334) 666-7278  
800-237-9859  
FAX: (334) 661-0223  
service@jones-mcleod.com

**GEORGIA:**

**GCS SERVICE INC**  
3127 PRESIDENTIAL DRIVE  
ATLANTA, GA 30340  
(770) 452-7322  
800-334-3599  
FAX: (770) 452-7473

**SOUTHEASTERN  
RESTAURANT SVC.**  
2200 NORCROSS PKWY.  
SUITE 210  
NORCROSS, GA 30071  
(770) 446-6177  
800-235-6516  
FAX: (770) 446-3157  
info@srs-atl.com

**WHALEY FOODSERVICE  
REPAIRS**  
109-A OWENS INDUSTRIAL  
DRIVE  
SAVANNAH, GA 31405  
(912) 447-0827  
888-765-0036  
FAX: (912) 447-0826

**HAWAII:**

**FOOD EQMT. PARTS & SER-  
VICE CO.**  
300 PUUHALE RD.  
HONOLULU, HI 96819  
(808) 847-4871  
FAX: (808) 842-1560  
fepsco@hula.net

**SECTION 5: JACKSON MAINTENANCE & REPAIR CENTERS****IDAHO TO MISSISSIPPI****IDAHO:**

**RON'S SERVICE**  
703 E 44TH STREET STE 10  
GARDEN CITY, ID 83714  
(208) 375-4073  
FAX: (208) 375-4402

**RESTAURANT APPLIANCE SVC.**  
7219 ROOSEVELT WAY NE  
SEATTLE, WA 98115  
(206) 524-8200  
800-433-9390  
FAX: (206) 525-2890  
info@restappl.com

**ILLINOIS:**

**CONES REPAIR SVC.**  
2408 40TH AVE.  
MOLINE, IL 61265  
(309) 797-5323  
800-716-7070  
FAX: (309)797-3631  
jackb@cones.com

**EICHENAUER SERVICES INC.**  
130 S OAKLAND ST.  
DECATUR, IL 62522  
(217) 429-4229  
800-252-5892  
FAX: (217) 429-0226  
esi@esiquality.com

**GCS SERVICE INC.**  
696 LARCH AVENUE  
ELMHURST, IL 60126  
(630) 941-7800  
800-942-9689  
FAX: (630) 941-6048

**GCS SERVICE INC.**  
9722 REAVIS PARK DRIVE  
ST. LOUIS, MO 63123  
(314) 683-7444  
800-284-4427  
FAX: (314) 638-0135

**INDIANA:**

**GCS SERVICE INC.**  
5310 E. 25TH STREET  
INDIANAPOLIS, IN 46218  
(317) 545-9655  
800-727-8710  
FAX: (317) 549-6286

**IOWA:**

**GOODWIN-TUCKER GROUP**  
3509 DELAWARE AVENUE  
DES MOINES, IA 50313  
(515) 262-9308  
800-372-6066  
FAX: (515) 262-2936  
goodwintuc@aol.com

**IOWA (cont.):**

**CONES REPAIR SVC.**  
1056 27TH AVENUE SW  
CEDAR RAPIDS, IA 52404  
(319) 365-3325  
800-747-3326  
FAX: (319) 365-0885

**KANSAS:**

**GCS SERVICE INC.**  
6107 CONNECTICUT  
KANSAS CITY, MO 64210  
(816) 920-5999  
800-229-6477  
FAX: (816) 920-7387

**KENTUCKY:**

**CERTIFIED SERVICE CENTER**  
127 DISHMAN LANE  
BOWLING GREEN, KY 42101  
(270) 783-0012  
(877) 907-0012  
FAX: (270) 783-0058

**CERTIFIED SERVICE CENTER**  
1051 GOODWIN DRIVE  
LEXINGTON, KY 40505  
(606) 254-8854  
800-432-9269  
FAX: (606) 231-7781  
jatkings@certifiedsc.com

**GCS SERVICE INC.**  
1002 NANDINO BLVD.  
LEXINGTON, KY 40511  
(606) 255-0746  
800-432-9260  
FAX: (606) 255-0748

**CERTIFIED SERVICE CENTER**  
RAMCO BUSINESS PARK  
4283 PRODUCE ROAD  
LOUISVILLE, KY 40218  
(502) 964-7007  
800-637-6350  
FAX: (502) 964-7202  
cwalker@certifiedsc.com  
droenigk@certifiedsc.com

**GCS SERVICE INC.**  
4204 SOUTH BROOK STREET  
LOUISVILLE, KY 40214  
(502) 367-1788  
800-752-6160  
FAX: (502) 367-0400

**LOUISIANA:**

**BANA PARTS INC.**  
1501 KUEBLE STREET  
HARAHAN, LA 70123  
(504) 734-0076  
800-325-7543  
FAX: (504) 734-8456

**LOUISIANA (cont.):**

**BANA PARTS INC.**  
4028 GREENWOOD ROAD  
SHREVEPORT, LA 71109  
(318) 631-6550  
800-832-6550  
FAX: (318) 636-5675

**MAINE:**

**MRE, INC.**  
170 JOHN ROBERTS RD UNIT #3  
PROTLAND, ME 04106  
(207) 772-1152  
800-823-9700  
FAX: (207) 772-1445

**NORTHERN CROWN SERVICES, INC.**  
225 INDUSTRIAL WAY  
PORTLAND, ME 04103  
(207) 797-7333  
(800) 696-7560  
FAX: (207) 696-1128  
steve@northerncrownservices.com  
richard@northerncrownservices.com

**MARYLAND:**

**EMR SERVICE DIVISION**  
700 EAST 25TH STREET  
BALTIMORE, MD 21218  
(410) 467-8080  
800-879-4994  
FAX: (410) 467-4191  
baltparts@emrco.com

**EMR SERVICE DIVISION**  
106 WILLIAMSPORT CIRCLE  
SALISBURY, MD 21804  
(410) 543-8197  
888-687-8080  
FAX: (410) 548-4038  
baltparts@emrco.com

**EMR SERVICE DIVISION**  
2626 PITTMAN DRIVE  
SILVER SPRING, MD 20910  
(301) 588-8080  
800-348-2365  
FAX: (301) 588-6985  
baltparts@emrco.com

**GCS SERVICE INC.**  
2660 PITTMAN DRIVE  
SILVER SPRING, MD 20910  
(301) 585-7550 (DC)  
(410) 792-0338 (BALT)  
(800) 638-7278  
FAX: (301) 495-4410

**MASSACHUSETTS:**

**ACE SERVICE CO.**  
95 HAMPTON AVE.  
NEEDHAM, MA 02494  
(781) 449-4220  
800-225-4510 MA & NH  
FAX: (781) 444-4789  
taceservice@aol.com

**MASSACHUSETTS RESTAURANT SUPPLY**  
34 SOUTH STREET  
SOMERVILLE, MA 02143  
(617) 868-1930  
800-338-6737  
FAX: (617) 868-5331

**GCS SERVICE INC.**  
180 SECOND STREET  
CHELSEA, MA 02150  
(617) 889-9393  
800-225-1155  
FAX: (617) 889-1222

**GCS SERVICE INC.**  
302 MURPHY ROAD  
HARTFORD, CT 06114  
(860) 549-5575  
800-723-1562  
FAX: (860) 527-6355

**MICHIGAN:**

**GCS SERVICE INC.**  
31829 WEST EIGHT MILE ROAD  
LIVONIA, MI 48152  
(248) 426-9500  
800-772-2936  
FAX: (248) 426-7555

**JACKSON SERVICE COMPANY**  
3980 BENSTEIN RD.  
COMMERCE TOWNSHIP, MI 48382  
(248) 363-4159  
800-332-4053  
FAX: (248) 363-5448

**MINNESOTA:**

**GCS SERVICE INC.**  
2857 LOUISIANA AVENUE N.  
MINNEAPOLIS, MN 55427  
(612) 546-4221  
800-345-4221  
FAX: (612) 546-4286

**MISSISSIPPI:**

**GCS SERVICE INC.**  
2815 19TH ANENUE, UNIT A  
GULFPORT, MS 39501  
(228) 864-2722  
877-964-2722  
FAX: (228) 822-9412

**SECTION 5: JACKSON MAINTENANCE & REPAIR CENTERS****MISSISSIPPI TO NORTH CAROLINA****MISSISSIPPI (cont.):**

**GCS SERVICE INC.**  
5755 GALLANT DRIVE.  
JACKSON, MS 39206  
(601) 956-7800  
800-274-5954  
FAX: (601) 956-1200

**GCS SERVICE INC.**  
3717 CHERRY ROAD  
MEMPHIS, TN 38118  
(901) 366-4587  
800-262-9155  
FAX: (901) 366-4588

**MISSOURI:**

**GCS SERVICE INC.**  
6107 CONNECTICUT  
KANSAS CITY, MO 64120  
(816) 920-5999  
800-229-6477  
FAX: (816) 920-7387

**GCS SERVICE INC.**  
9722 REAVIS PARK DRIVE  
ST. LOUIS, MO 63123  
(314) 638-7444  
800-284-4427  
FAX: (314) 638-0135

**KAMMERLIN PARTS & SVC.**  
1359 SOUTH KINGSHIGHWAY  
ST. LOUIS, MO 63110  
(314) 535-2222  
FAX: (314) 535-6205  
petek@kps.stl.com

**MONTANA:**

**RESTAURANT  
APPLIANCE SVC.**  
7219 ROOSEVELT WAY NE  
SEATTLE, WA 98115  
(206) 524-8200  
800-433-9390  
FAX: (206) 525-2890  
info@restappl.com

**NEBRASKA:**

**GOODWIN - TUCKER GROUP**  
7535 D STREET  
OMAHA, NE 68124  
(402) 397-2880  
800-228-0372  
FAX: (402) 397-2881  
goodwintuc@aol.com

**NEVADA:**

**HI TECH COMMERCIAL SVC**  
400 E. MEAD BLVD.  
LAS VEGAS, NV 89030  
(702) 649-4616  
(877) 924-4832  
FAX: (702) 649-4607

**GCS SERVICE INC.**  
LAS VEGAS, NV  
800-822-2303

**NEW HAMPSHIRE:**

**GCS SERVICE INC.**  
180 SECOND STREET  
CHELSEA, MA 02150  
(617)889-9393  
800-225-1155  
FAX: (617) 889-1222

**ACE SERVICE CO.**  
500 HARVEY RD.  
MANCHESTER, NH 03103  
(603) 668-5070  
800-225-4510  
FAX: (603) 626-6067  
taceservice@aol.com

**MASSACHUSETTS  
RESTAURANT SUPPLY**  
34 SOUTH STREET  
SOMERVILLE, MA 02143  
(617) 868-1930  
800-338-6737  
FAX: (617) 868-5331

**NEW JERSEY:**

**JACKSON FASPRAY SVC.**  
155 SARGEANT AVE.  
CLIFTON, NJ 07013  
(973) 471-8000  
800-356-6740  
FAX: (973) 471-1289  
jfs155@aol.com

**AMERICAN KITCHEN  
MACHINERY & REPAIR**  
204 QUARRY STREET  
PHILADELPHIA, PA 19106  
(215) 627-7760  
800-848-7760  
FAX: (215) 627-1604

**GCS SERVICE INC.**  
817 N. THIRD STREET  
PHILADELPHIA, PA 19123  
(215) 925-6217  
800-441-9115  
FAX: (215) 925-6208

**NEW JERSEY (cont.):**

**ELMER SCHULTZ SERVICES**  
201 WASHINGTON AVE.  
PLEASANTVILLE, NJ 08232  
(609) 641-0317  
800-378-1641  
FAX: (609) 641-8703  
elmer2@erols.com

**NEW MEXICO:**

**STOVE PARTS SUPPLY CO.**  
2120 SOLANA STREET  
FORT WORTH, TX 76117  
(817) 831-0381  
800-433-1804  
FAX: (817) 834-7754  
bud@stoveparts.com

**HAWKINS COMMERCIAL APPLI-  
ANCE SERVICE**  
300 S. WYANDOT STREET  
ENGLEWOOD, CA 80110  
(303) 781-5548  
800-624-2117  
FAX: (303) 761-8861

**NEW YORK:**

**GCS SERVICE INC.**  
BROOKLYN, NY 11211  
800-822-2303

**APPLIANCE INSTALLATION  
AND SERVICE CORP.**  
1336 MAIN STREET  
BUFFALO, NY 14209  
(716) 884-7425  
800-722-1252  
FAX: (716) 884-0410  
ais@worldnet.att.net

**B.E.S.T. INC.**  
3003 GENESEE STREET  
BUFFALO, NY 14225  
(716) 893-6464  
800-338-5011  
FAX: (716) 893-6466  
bestserv@aol.com

**DUFFY'S EQUIPMENT SVC.**  
3138 ONEIDA STREET  
SAUQUOIT, NY 13456  
(315) 737-9401  
800-443-8339  
FAX: (315) 737-7132  
duffyequip@aol.com

**NORTHERN PARTS & SVC.**  
21 NORTHERN AVENUE  
PLATTSBURGH, NY 12903  
(518) 563-3200  
800-634-5005  
FAX: (800) 782-5424  
info@northernparts.com

**NEW YORK (cont.):**

**JACKSON FASPRAY SVC.**  
155 SARGEANT AVE.  
CLIFTON, NJ 07013  
(973) 471-8000  
800-356-6740  
FAX: (973) 471-1289  
jfs155@aol.com

**ALL ISLAND REPAIR**  
40-9 BURT DRIVE  
DEER PARK, NY 11729  
(631) 242-5588  
800-323-9411  
FAX: (631) 242-6102

**A. I. S. COMMERCIAL  
PARTS & SVC**  
1900 COLLEGE AVENUE  
ELMIRA HEIGHTS, NY 14901  
(607) 734-6072  
888-724-7377  
FAX: (607) 734-9294

**A. I. S. COMMERCIAL  
PARTS & SVC**  
13 WESTR MAIN STREET  
FALCONER, NY 14733  
(716) 665-6556  
800-552-6556  
FAX: (716) 665-4227

**A. I. S. COMMERCIAL  
PARTS & SVC**  
200 SALINA ST. SUITE 114  
LIVERPOOL, NY 13088  
(315) 435-0709  
800-371-5921  
FAX: (315) 453-1412

**A. I. S. COMMERCIAL  
PARTS & SVC**  
7387 PITTSFORD VICTOR RD.  
ROCHESTER, NY 14610  
(716) 461-2370  
800-458-4198  
FAX: (716) 461-5545

**NORTH CAROLINA:**

**AUTHORIZED APPLIANCE  
SERVICE CENTER**  
1020 TUCKASEEGEE RD.  
CHARLOTTE, NC 28208  
(704) 377-4501  
(800) 532-6127  
FAX: (704) 377-4504

**WHALEY FOODSERVICE**  
203-D CREEK RIDGE RD.  
GREENSBORO, NC 27604  
(336) 333-2333  
FAX: (336) 333-2533

**SECTION 5: JACKSON MAINTENANCE & REPAIR CENTERS****NORTH CAROLINA TO TEXAS****NORTH CAROLINA (cont.):****AUTHORIZED APPLIANCE SERVICE CENTER**

109 HINTON AVE.  
WILMINGTON, NC 28403  
(910) 313-1250  
FAX: (910) 313-6130

**WHALEY FOODSERVICE**

8334-K ARROWRIDGE BLVD  
CHARLOTTE, NC 28273  
(704) 529-6242  
FAX: (704) 529-1558  
info@whaleyfoodservice.com

**WHALEY FOODSERVICE REPAIRS**

335-105 SHERWEE DRIVE  
RALEIGH, NC 27603  
(919) 779-2266  
FAX: (919) 779-2224  
info@whaleyfoodservice.com

**WHALEY FOODSERVICE REPAIRS**

6418-101 AMSTERDAM WAY  
WILMINGTON, NC 28405  
(910) 791-0000  
FAX: (910) 791-6662  
info@whaleyfoodservice.com

**NORTH DAKOTA:****GCS SERVICE INC.**

2857 LOUISIANA AVENUE N.  
MINNEAPOLIS, MN 55427  
(612) 546-4221  
800-345-4221  
FAX: (612) 546-4286

**OHIO:****CERTIFIED SERVICE CENTER**

890 REDNA TERRACE  
CINCINNATI, OH 45215  
(513) 772-6600  
800-543-2060  
FAX: (513) 612-6600  
sbarasch@certifiedsc.com

**CERTIFIED SERVICE CENTER**

6025 N. DIXIE DRIVE  
DAYTON, OH 45414  
(937) 898-4040  
(800) 257-2611  
FAX: (937) 898-4177  
dharvey@certifiedsc.com

**COMMERCIAL PARTS & SVC. OF COLUMBUS**

1150 WEST MOUND STREET  
COLUMBUS, OH 43223  
(614) 221-0057  
800-837-8327  
FAX: (614) 221-3622

**OHIO (cont.):****GCS SERVICE INC.**

2830 JOHNSTON RD.  
COLUMBUS, OH 43219  
(614) 476-3225  
800-282-5406  
FAX: (614) 476-1196

**ELECTRICAL APPLIANCE REPAIR SVC.**

5805 VALLEY BELT ROAD  
CLEVELAND, OH 44131  
(216) 459-8700  
800-621-8259  
FAX: (216) 459-8707  
tomr@electapplrep.com

**OKLAHOMA:****HAGAR RESTAURANT EQMT.**

1229 W MAIN STREET  
OKLAHOMA CITY, OK 73106  
(405) 235-2184  
800-445-1791  
FAX: (405) 236-5592

**OREGON:****RON'S SERVICE**

16364 SW 72ND AVE  
PORTLAND, OR 97224  
(503) 624-0890  
800-851-4118  
FAX: (503) 684-6107  
lrobinson@ronsservice.com

**PENNSYLVANIA:****A.I.S. COMMERCIAL PARTS & SERVICE**

1816 WEST 26TH STREET  
ERIE, PA 16508  
(814) 456-3732  
800-332-3732  
FAX: (814) 452-4843  
aiserie@aol.com

**ELMER SCHULTZ SVC.**

540 NORTH 3RD STREET  
PHILADELPHIA, PA 19123  
(215) 627-5400  
FAX: (215) 627-5408  
elmer2@erols.com

**K & D PARTS & SERVICE**

1833-41 N. CAMERON STREET  
HARRISBURG, PA 17103  
(717) 236-9039  
800-932-0503  
FAX: (717) 238-4367

**PENNSYLVANIA (cont.):****AMERICAN KITCHEN MACHINERY & REPAIR**

204 QUARRY STREET  
PHILADELPHIA, PA 19106  
(215) 627-7760  
800-848-7760  
FAX: (215) 627-1604

**GCS SERVICE INC.**

817 N. THIRD STREET  
P.O. BOX 3564  
PHILADELPHIA, PA 19123  
(215) 925-6217  
800-441-9115  
FAX: (215) 925-6208

**GCS SERVICE INC.**

210 VISTA PARK DRIVE  
PITTSBURGH, PA 15205  
(412) 787-1970  
800-738-1221  
FAX: (412) 787-5005

**RHODE ISLAND:****GCS SERVICE INC.**

180 SECOND STREET  
CHELSEA, MA 02150  
(617)889-9393  
800-225-1155  
FAX: (617) 889-1222

**SOUTH CAROLINA:****AUTHORIZED APPLIANCE SERVICECENTER**

1811 TAYLOR ST.  
COLUMBIA, SC 29202  
(803) 254-8414  
FAX: (803) 254-5146

**AUTHORIZED APPLIANCE SERVICECENTER**

2249 AUGUSTA RD.  
GREENVILLE, SC 29605  
(864) 235-9616  
FAX: (864) 235-9623

**WHALEY FOODSERVICE REPAIRS**

I 26 & US1  
P.O. BOX 4023  
WEST COLUMBIA, SC 29170  
(803) 791-4420  
800-877-2662  
FAX: (803) 794-4630  
info@whaleyfoodservice.com

**WHALEY FOODSERVICE REPAIRS**

748 CONGAREE ROAD  
GREENVILLE, SC 29607  
(864) 234-7011  
800-494-2539  
FAX: (864) 234-6662  
info@whaleyfoodservice.com

**SOUTH CAROLINA (cont.):****WHALEY FOODSERVICE REPAIRS**

1406-C COMMERCE PL.  
MYRTLE BEACH, SC 29577  
(843) 626-1866  
FAX: (843) 626-2632  
info@whaleyfoodservice.com

**WHALEY FOODSERVICE REPAIRS**

4740-A FRANCHISE STREET  
N. CHARLESTON, SC 29418  
(843) 760-2110  
FAX: (843) 760-2255  
info@whaleyfoodservice.com

**SOUTH DAKOTA:****GCS SERVICE INC.**

2857 LOUISIANA AVENUE N.  
MINNEAPOLIS, MN 55247  
(612) 546-4221  
800-345-4221  
FAX: (612) 546-4286

**TENNESSEE:****GCS SERVICE INC.**

3717 CHERRY ROAD  
MEMPHIS, TN 38118  
(901) 366-4587  
800-262-9155  
FAX: (901) 366-4588

**GCS SERVICE INC.**

748 FESSLERS LANE  
NASHVILLE, TN 37210  
(615) 244-8050  
800-831-7174  
FAX: (615) 244-8885

**TEXAS:****GCS SERVICE INC.**

AUSTIN, TX  
800-822-2303

**ARMSTRONG REPAIR CENTER**

1700 S LAMAR BLVD #327  
AUSTIN, TX 78704  
(512) 416-1101  
800-392-5322  
FAX: (512) 416-6912

**ARMSTRONG REPAIR CENTER**

5110 GLENMONT DRIVE  
HOUSTON, TX 77081  
(713) 666-7100  
800-392-5325  
FAX: (713) 661-0520  
gm@armstrongrepair.com

## SECTION 5: JACKSON MAINTENANCE & REPAIR CENTERS

### TEXAS TO WYOMING/CANADA

#### TEXAS (cont.):

**COMMERCIAL KITCHEN REPAIR CO.**  
1377 N BRASOS  
P.O BOX 831128  
SAN ANTONIO, TX 78207  
(210) 735-2811  
800-292-2120  
FAX: (210) 735-7421  
brock@commercialkitchen.com

**GCS SERVICE INC.**  
440 WRANGLER DRIVE #100  
COPPELL, TX 75019  
(972) 906-0307  
800-442-5026  
FAX: (972) 906-9886

**GCS SERVICE INC.**  
HOUSTON, TX  
800-822-2303

**GCS/STOVE PARTS**  
2120 SOLANA STREET  
FORT WORTH, TX 76117  
(817) 831-0381  
800-433-1804  
FAX: (817) 834-7754  
bud@stoveparts.com

#### UTAH:

**LA MONICA'S RESTAURANT EQMT. SVC.**  
6182 SOUTH STRATLER AVENUE  
MURRAY, UT 84107  
(801) 263-3221  
800-527-2561  
FAX: (801) 263-3229  
lamonica81@aol.com

**GCS SERVICE INC.**  
1366 S. 400 WEST  
SALT LAKE CITY, UT 84115  
(801) 487-3653  
800-955-9201  
FAX: (801) 487-2253

#### VERMONT:

**NORTHERN PARTS & SVC.**  
4874 S. CATHERINE STREET  
PLATTSBURGH, NY 12901  
(518) 563-3200  
800-634-5005  
FAX: (800) 782-5424  
info@northernparts.com

**GCS SERVICE INC.**  
180 SECOND STREET  
CHELSEA, MA 02150  
(617)889-9393  
800-225-1155  
FAX: (617) 889-1222

#### VIRGINIA:

**DAUBERS, INC.**  
7645 DYNATECH COURT  
SPINGFIELD, VA 22153  
(703) 866-3600  
800-554-7788  
FAX: (703) 866-4071  
daubers@aol.com

**GCS SERVICE INC.**  
2660 PITTMAN DRIVE  
SILVER SPRING, MD 20910  
(301) 585-7550(DC)  
(410) 792-0388(BALT)  
800-638-7278  
FAX: (301)495-4410

**GCS SERVICE INC.**  
RICHMOND, VA  
800-822-2303

#### WASHINGTON:

**RESTAURANT APPLIANCE SVC**  
7219 ROOSEVELT WAY, NE  
SEATTLE, WA 98115  
(206) 524-8200  
800-433-9390  
FAX: (206) 525-2890  
info@restappl.com

#### WEST VIRGINIA:

**STATEWIDE SERVICE, INC.**  
603 MAIN AVE.  
NITRO, WV 25143  
(304) 755-1811  
(800) 441-9739  
FAX: (304) 755-4001  
sws3182@aol.com

#### WISCONSIN:

**APPLIANCE SERVICE CENTER, INC.**  
2439 ATWOOD AVE  
MADISON, WI 53704  
(608) 246-3160  
800-236-7440  
FAX: (608) 246-2721  
ascmad@execpc.com

**APPLIANCE SERVICE CENTER, INC.**  
6843 W. BELLOIT RD.  
WEST ALLIS, WI 53219  
(414) 543-6460  
800-236-6460  
FAX: (414) 543-6480  
ascmil@execpc.com

#### WISCONSIN (cont.):

**APPLIANCE SERVICE CENTER**  
786 MORRIS AVE  
GREEN BAY, WI 54304  
(920) 496-9993  
800-236-0871  
FAX: (920) 496-9927  
ascfox@execpc.com

**METROPOLITAN SERVICE**  
3210 LONDON RD.  
EAU CLAIRE, WI 54701  
(715) 832-0555  
800-848-3945  
FAX: (715) 832-7813

#### WYOMING:

**HAWKINS COMMERCIAL APPLIANCE SERVICE**  
300 S. WYANDOT ST.  
ENGLEWOOD, CO 80110  
(303) 781-5548  
(800) 624-2117  
FAX: (303) 761-5561  
johns@hawkinscommercial.com

**METRO APPLIANCE SERVICE**  
1640 S BROADWAY  
DENVER, CO 80210  
(303) 778-1126  
800-525-3532  
FAX: (303) 778-0268  
metroappls@aol.com

#### CANADA

**Garland Commercial Ranges, Ltd.**  
1177 KAMATO ROAD  
MISSISSAUGA, ONTARIO L4W 1X4  
(905) 624-0260  
800-427-6668  
FAX: (905) 624-0623