

# INSTALLATION, OPERATION & SERVICE MANUAL

INSTALLATION MANUAL FOR EXPORT UNITS  
SERVICE MANUAL FOR DOMESTIC UNITS

## ***ELECTRICALLY HEATED MODELS:***

TEMPSTAR HH  
TEMPSTAR HH NB  
TEMPSTAR HH LT  
TEMPSTAR HH VENTLESS

## ***STEAM HEATED MODELS:***

TEMPSTAR HH S



## ***Warewashing Systems***



# **MANUFACTURERS WARRANTY**

## **ONE YEAR LIMITED PARTS & LABOR WARRANTY**

**ALL NEW JACKSON DISHWASHERS ARE WARRANTED TO THE ORIGINAL PURCHASER TO BE FREE FROM DEFECTS IN MATERIAL OR WORKMANSHIP, UNDER NORMAL USE AND OPERATION FOR A PERIOD OF (1) ONE YEAR FROM DATE OF PURCHASE, BUT IN NO EVENT TO EXCEED (18) EIGHTEEN MONTHS FROM DATE OF SHIPMENT FROM THE FACTORY.**

Jackson WWS agrees under this warranty to repair or replace, at its discretion, any original part which fails under normal use due to faulty material or workmanship during the warranty period, providing the equipment has been unaltered, and has been properly installed, maintained and operated in accordance with applicable factory instruction manual furnished with the machine and failure is reported to the authorized service agency within the warranty period. This includes the use of factory specified genuine replacement parts, purchased directly from a Jackson authorized parts distributor or service agency. Use of generic replacement parts may create a hazard and void warranty certification.

The labor to repair or replace such failed part will be paid by Jackson WWS, within the continental United States, Hawaii and Canada, during the warranty period provided a Jackson WWS authorized service agency, or those having prior authorization from the factory, performs the service. Any repair work by persons other than Jackson WWS authorized service agency is the sole responsibility of the customer. Labor coverage is limited to regular hourly rates; overtime premiums and emergency service charges will not be paid by Jackson WWS.

Accessory components not installed by the factory carry a (1) one year parts warranty only. Accessory components such as table limit switches, pressure regulators, pre-rinse units, etc. that are shipped with the unit and installed at the site are included. Labor to repair or replace these components is not covered by Jackson WWS.

This warranty is void if failure is a direct result from shipping, handling, fire, water, accident, misuse, acts of God, attempted repair by authorized persons, improper installation, if serial number has been removed or altered, or if unit is used for purpose other than originally intended.

### **TRAVEL LIMITATIONS**

Jackson WWS limits warranty travel time to (2) two hours and mileage to (100) one hundred miles. Jackson WWS will not pay for travel time and mileage that exceeds this, or any fees such as those for air or boat travel without prior authorization.

### **WARRANTY REGISTRATION**

To register your product go to [www.jacksonwws.com](http://www.jacksonwws.com) or call 1-888-800-5672. Failure to register your product will void the warranty.

### **REPLACEMENT PARTS WARRANTY**

Jackson replacement parts are warranted for a period of 90 days from date of installation or 180 days from the date of shipment from the factory, whichever occurs first.

### **PRODUCT CHANGES AND UPDATES**

Jackson WWS reserves the right to make changes in design and specification of any equipment as engineering or necessity requires.

**THIS IS THE ENTIRE AND ONLY WARRANTY OF JACKSON WWS. JACKSON'S LIABILITY ON ANY CLAIM OF ANY KIND, INCLUDING NEGLIGENCE, WITH RESPECT TO THE GOODS OR SERVICES COVERED HEREUNDER, SHALL IN NO CASE EXCEED THE PRICE OF THE GOODS OR SERVICES OR PART THEREOF WHICH GIVES RISE TO THE CLAIM.**

**THERE ARE NO WARRANTIES, EXPRESSED OR IMPLIED, INCLUDING FOR FITNESS OR MERCHANTABILITY, THAT ARE NOT SET FORTH HEREIN, OR THAT EXTEND BEYOND THE DURATION HEREOF. UNDER NO CIRCUMSTANCES WILL JACKSON WWS BE LIABLE FOR ANY LOSS OR DAMAGE, DIRECT OR CONSEQUENTIAL, OR FOR THE DAMAGES IN THE NATURE OF PENALTIES, ARISING OUT OF THE USE OR INABILITY TO USE ANY OF ITS PRODUCTS.**

### **ITEMS NOT COVERED**

**THIS WARRANTY DOES NOT COVER CLEANING OR DELIMING OF THE UNIT OR ANY COMPONENT SUCH AS, BUT NOT LIMITED TO, WASH ARMS, RINSE ARMS OR STRAINERS AT ANYTIME. NOR DOES IT COVER ADJUSTMENTS SUCH AS, BUT NOT LIMITED TO TIMER CAMS, THERMOSTATS OR DOORS, BEYOND 30 DAYS FROM THE DATE OF INSTALLATION. IN ADDITION, THE WARRANTY WILL ONLY COVER REPLACEMENT WEAR ITEMS SUCH AS CURTAINS, DRAIN BALLS, DOOR GUIDES OR GASKETS DURING THE FIRST 30 DAYS AFTER INSTALLATION. ALSO, NOT COVERED ARE CONDITIONS CAUSED BY THE USE OF INCORRECT (NON-COMMERICAL) GRADE DETERGENTS, INCORRECT WATER TEMPERATURE OR PRES-SURE, OR HARD WATER CONDITIONS.**

## REVISION HISTORY

Revision Letter	Revision Date	Made By	Applicable ECNs	Details
F	06-01-04	MAW	N/A	Change to new layout.
G	01-05-05	MAW	N/A	Corrected amerate ratings, changed to thermostat bracket 05700-011-81-64, changed thermostat 05930-121-71-29 to thermostat kit 06401-140-00-32, updated drawing for false panel installation, and added SDI override instructions.
H	01-17-06	MAW	7609	Added universal timer, parts & schematics.
I	07-06-06	MAW	7713, 7571, 7493, 7553, 7411, 7422, 7231	Updated specification & dimension pages. Updated drain quench assembly. Replaced door switch 05930-003-02-20 with 05930-003-05-84. Added false panel kit numbers, door component kits. Replace ball stop components. Replace thermostat 05930-121-71-29 with 05930-510-03-79. Added the wash & rinse thermometer decals.
J	09-14-07	MAW		Obsoleting I/O manual, added warranty & repair centers. Listed minimum cycle times. Added Top Mount Control Box: dimensions, hood weldment, control box & schematics. Corrected the rinse tank cover number, updated the cantilever support bracket & reed switch numbers.
K	10-08-08	ARL	7990	Added hi-limit thermostat set point instructions.
L	01-10-13	RLC	8252	Updated schematic and control box to reflect rotary switch.
M	03-07-13	RLC	QOF NDB-219	Updated Jackson logo and company name.
N	03-24-14	MHH		Updated warranty page. Removed "Stop" page. Converted manual from Quark to InDesign.
O	04-16-14	MHH	8291	Changed pages 22, 25, 28 & 31
P	06-04-14	MHH	8287	New part & # for bearing on rinse arm assy, pg. 41.
Q	10-28-14	KAP	8298	Updated pg's. 4, 5, & 23 to accommodate new door's and new Cantilever Arm.
R	12-01-14	KAP	N/A	Updated assembly numbers on pg. 31
S	04-06-15	KAP	N/A	Inserted note pertaining to corner installation pg. 6
T	04-07-15	KAP	ECR 8329	Added Tempstar HH, NB 208V-230V, 60HZ, Single phase pg. 54
U	06-05-15	KAP	N/A	Added Tempstar HH LT & Tempstar HH Ventless components Updated solid state schematics on pg 60 & 61 Added NB/LT Schematic on page 69. Updated 208-230V, 60HZ on page 65.



**TEMPSTAR HH**

Electrically heated, high temp, hot water sanitizing, with booster heater, door-type dishmachine

**TEMPSTAR HH NB**

Electrically heated, high temp, hot water sanitizing, no rinse booster, door-type dishmachine

**TEMPSTAR HH LT**

Electrically heated, low temp, chemical sanitizing, door-type dishmachine

**TEMPSTAR HH VENTLESS**

Electrically heated high temp, hot water sanitizing, with booster heater and ventless heat recovery system

**TEMPSTAR HH S**

Steam heated, high temp, hot water sanitizing, door-type dishmachine

**Model:** \_\_\_\_\_

**Serial No.:** \_\_\_\_\_

**Installation Date:** \_\_\_\_\_

**Service Rep. Name:** \_\_\_\_\_

**Phone Number:** \_\_\_\_\_

Jackson WWS, INC provides technical support for all of the dishmachines detailed in this manual. We strongly recommend that you refer to this manual before making a call to our technical support staff. Please have this manual with you when you call so that our staff can refer you, if necessary, to the proper page. Technical support is not available on holidays. Contact technical support from 8:00 a.m. to 5:00 p.m. (EST), Monday through Friday, toll free at 1-888-800-5672. Please remember that technical support is available for service personnel only.

# TABLE OF CONTENTS

---

## SPECIFICATIONS

Operating Capacities .....	2
Electrical Requirements .....	3
Dimensions Tempstar/Tempstar LT/Tempstar NB (Top Mounted Control Box) .....	4
Table Dimensions .....	7

## INSTALLATION & OPERATION

Installation Instructions .....	8
Electrical Installation Instructions .....	9
Ventless Heat Recovery Mounting .....	11
Operating Instructions .....	15
False Panel Installation .....	18

## PREVENTATIVE MAINTENANCE..... 19

## TROUBLESHOOTING ..... 20

## PARTS

Top Mounted Control Box Assembly (Universal Timer) .....	22
Side Mounted Control Box Assembly (Universal Timer).....	26
Side Mounted Control Box Assembly (Mechanical Timer) .....	29
Hood Assembly (Bolted Single Support Design) .....	30
Cantilever Arm/Door Assemblies .....	32
Tub Assembly .....	34
Steam Tub Assembly.....	37
Frame Assembly.....	39
Rinse Tank Assembly .....	40
Coil Assembly.....	41
Incoming Steam Plumbing Assembly .....	42
Wash Motor.....	43
Incoming Plumbing/Outlet Plumbing Assemblies .....	44
Ventless Heat Recovery Plumbing Assemblies .....	48
Drain Quench Assembly.....	50
1/2" Solenoid Valve & 1/2" NPT Vacuum Breaker Repair Parts Kits .....	51
Wash & Rinse Arm/Manifold Assemblies.....	52
Transformer Mounting Box Components.....	54
Exhaust Fan Control.....	55
Ventless Heat Recovery Assembly.....	56
Door Interlock.....	58

**SCHEMATICS**

Solid State (Top Mount Control Box) 208-230V, 50/60Hz, Single/Three Phase.....	60
Tempstar HH (Universal Timer) 208-230V, 50/60Hz, Single/Three Phase.....	61
Solid State (Top Mount Control Box) 460V, 60Hz, Three Phase.....	62
Tempstar HH (Universal Timer) 460V, 60Hz, Three Phase.....	63
Tempstar HH S (Universal Timer) 208-230V, 50/60Hz, Single/Three Phase.....	64
Tempstar HH 208-230V, 50/60Hz, Single/Three Phase.....	65
Tempstar HH 460V, 60Hz, Three Phase.....	66
Tempstar HH S 208V-230V, 60HZ, Single/Three Phase.....	67
Tempstar HH, NB 208/230V, 50/60Hz, Single Phase.....	68
Solid State Tempstar HH, NB/LT 208-230V, 50/60Hz Single Phase.....	69
SDI Option.....	70
Exhaust Fan Hookup/Drain Quench Options.....	71

# SPECIFICATIONS

## OPERATING CAPACITIES

### OPERATING CAPACITY:

#### **Selection A**

Racks per Hour	53
Dishes per Hour	1325
Glasses per Hour	1325

#### **Selection B**

Racks per Hour	29
Dishes per Hour	725
Glasses per Hour	725

#### **Selection C**

Racks per Hour	20
Dishes per Hour	500
Glasses per Hour	500

### OPERATING CYCLE (SECONDS):

#### **Minimum (other cycle times are available)**

	<b>LT</b>	<b>HT</b>
Wash Time	45	45
Rinse Time	14	15
Total Cycle Time	59	60

#### High Temperature Ventless

Wash Time	45
Rinse Time	15
Dwell Time	2
Condensate Removal	30
Total Cycle Time	92

#### **Tank Capacity:**

Rinse Tank (gallons)	N/A	3.0
Rinse Tank (liters)	N/A	11.4
Wash Tank (gallons)	14	8.0
Wash Tank (liters)	30.3	30.3

### ELECTRICAL REQUIREMENTS:

Wash Motor HP	2.0
---------------	-----

**NOTE: Always refer to the machine data plate for specific electrical and water requirements. The material provided on this page is for reference only and is subject to change without notice.**

### WATER REQUIREMENTS:

#### **Tempstar HH & Tempstar HH Ventless:**

Wash Temperature (minimum) (°F)	150
Wash Temperature (minimum) (°C)	66
Rinse Temperature (minimum) (°F)	180
Rinse Temperature (minimum) (°C)	83
Inlet Water Temperature:	
12kW Rinse Heater (°F)	140
12kW Rinse Heater (°C)	60
14kW Rinse Heater (°F)	110
14kW Rinse Heater (°C)	44
14KW Ventless (°F)	40-70
14KW Ventless (°C)	4.4-21
Flow Pressure (PSI)	20±5
Water Line Size (NPT)	3/4"
Drain Line Size (NPT)	1 1/2"

#### **Tempstar HH NB/Tempstar HH S:**

Wash Temperature (minimum) (°F)	150
Wash Temperature (minimum) (°C)	66
Rinse Temperature (minimum) (°F)	180
Rinse Temperature (minimum) (°C)	83
Inlet Water Temperature (°F)	180
Inlet Water Temperature (°C)	83
Flow Pressure (PSI)	20±5
Water Line Size (NPT)	3/4"
Drain Line Size (NPT)	1 1/2"

#### **Tempstar HH LT:**

Wash Temperature (minimum) (°F)	120
Wash Temperature (minimum) (°C)	49
Rinse Temperature (minimum) (°F)	120
Rinse Temperature (minimum) (°C)	49
Inlet Water Temperature (°F)	120
Inlet Water Temperature (°C)	49
Flow Pressure (PSI)	20±5
Water Line Size (NPT)	1/2"
Drain Line Size (NPT)	1 1/2"

### STEAM REQUIREMENTS:

Coil Size	3/4"
Steam Flow Pressure (PSI)	10-20
Consumption @ 15 PSI (lbs./hr.)	45



# SPECIFICATIONS

## ELECTRICAL REQUIREMENTS

**NOTE: Typical Electrical Circuit is based upon (1) 125% of the full amperage load of the machine and (2) typical fixedtrip circuit breaker sizes as listed in the NEC 2002 Edition. Local codes may require more stringent protection than what is displayed here. Always verify with your electrical service contractor that your circuit protection is adequate and meets all applicable national and local codes. These numbers are provided in this manual simply for reference and may change without notice at any given time.**

**TEMPSTAR HH:**

Volts	Phase	Freq	Rinse Heater Ratings	Total Amps	Typical Electrical Circuit
415	3	60	12kW	28A	35AMP
415	3	60	14kW	30A	40AMP
208	1	60	12kW@240V	75A	100AMP
208	1	60	12kW@240V	82A	110AMP
230	1	60	12kW@240V	81A	110AMP
230	1	60	14kW@240V	90A	125AMP
208	3	60	12kW@240V	48A	60AMP
208	3	60	14kW@240V	52A	70AMP
230	3	60	12kW@240V	52A	70AMP
230	3	60	14kW@240V	57A	80AMP
460	3	60	12kW@480V	24A	30AMP
460	3	60	14kW@480V	26A	35AMP

**TEMPSTAR HH NB & TEMPSTAR HH LT:**

Volts	Phase	Freq	Rinse Heater Ratings	Total Amps	Typical Electrical Circuit
208	1	60	N/A	31A	35AMP
230	1	60	N/A	33A	35AMP
208	3	60	N/A	23A	25AMP
230	3	60	N/A	24A	35AMP
460	3	60	N/A	10A	15AMP

**TEMPSTAR HH S:**

Volts	Phase	Freq	Rinse Heater Ratings	Total Amps	Typical Electrical Circuit
208	1	60	N/A	12A	15AMP
230	1	60	N/A	12A	15AMP
208	3	60	N/A	12A	15AMP
230	3	60	N/A	12A	15AMP

# SPECIFICATIONS

## DIMENSIONS (TOP MOUNT CONTROL BOX)

### LEGEND

A - Drain 1 1/2" IPS

B - Water Inlet 3/4" IPS

C - Electrical Connection

All vertical dimensions are +/- 1/2" due to adjustable bullet feet.

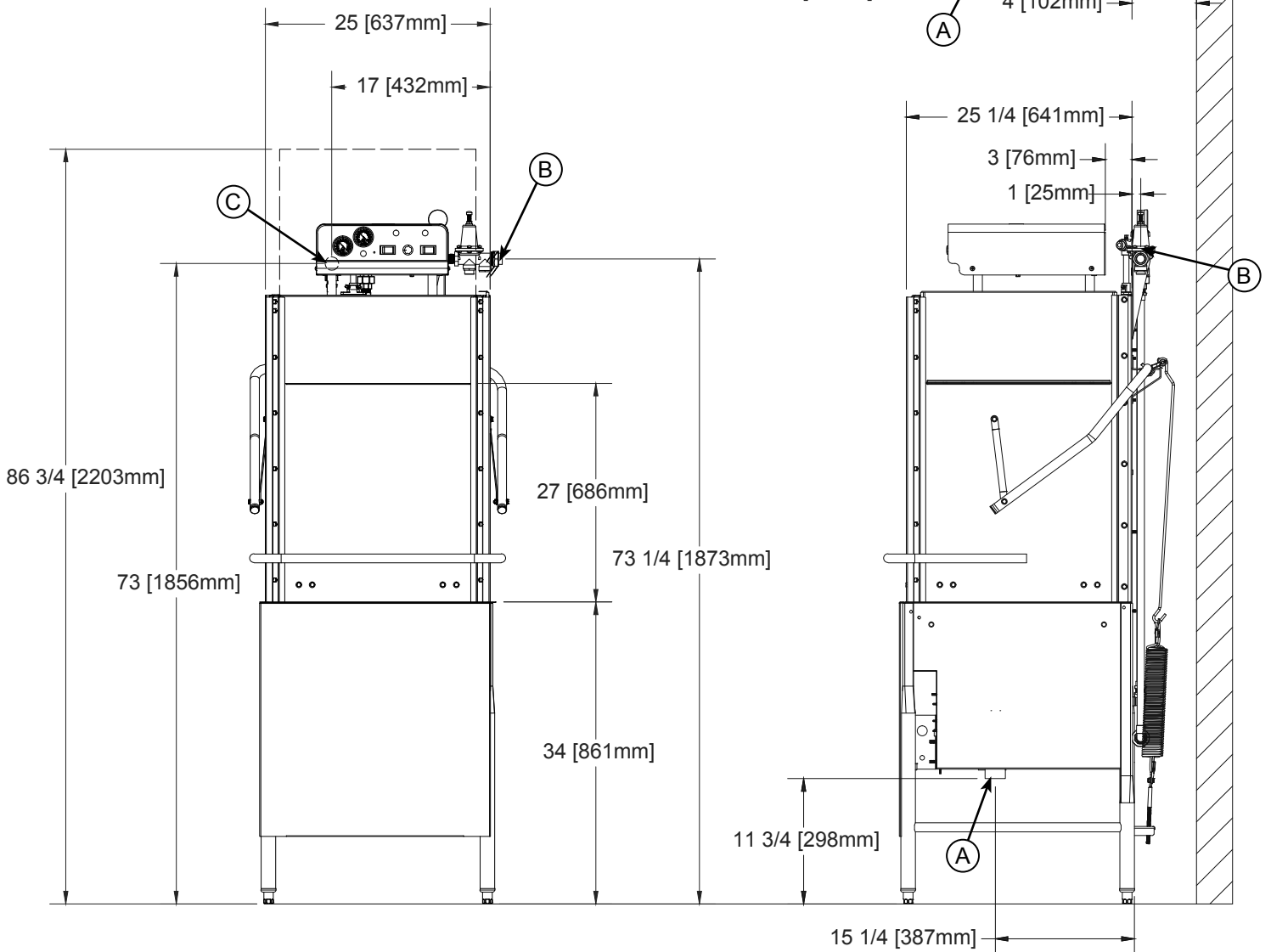

# SPECIFICATIONS

## DIMENSIONS (SIDE MOUNT CONTROL BOX)

### LEGEND

- A - DRAIN 1 1/2" IPS
- B - WATER INLET 3/4" IPS
- C - ELECTRICAL CONNECTION

All dimensions are in inches. All vertical dimensions are +/- 1/2" due to adjustable bullet feet.

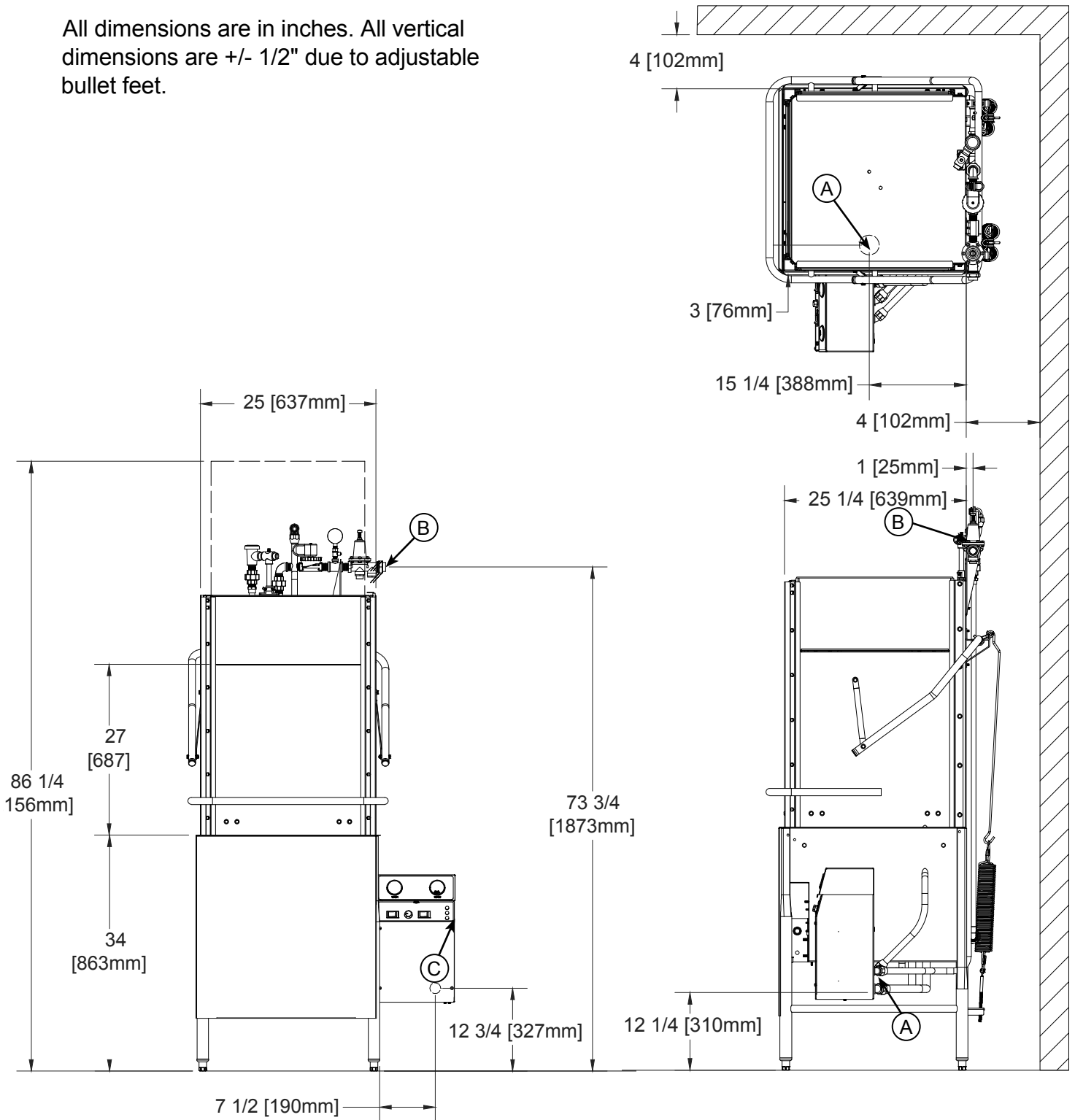

# SPECIFICATIONS

## DIMENSIONS (LEFT SIDE CONTROL BOX)

### LEGEND

- A - Drain 1 1/2"
- B - Water Inlet 3/4"
- C - Electrical Connection

All vertical dimensions are +/- 1/2" due to adjustable bullet feet.

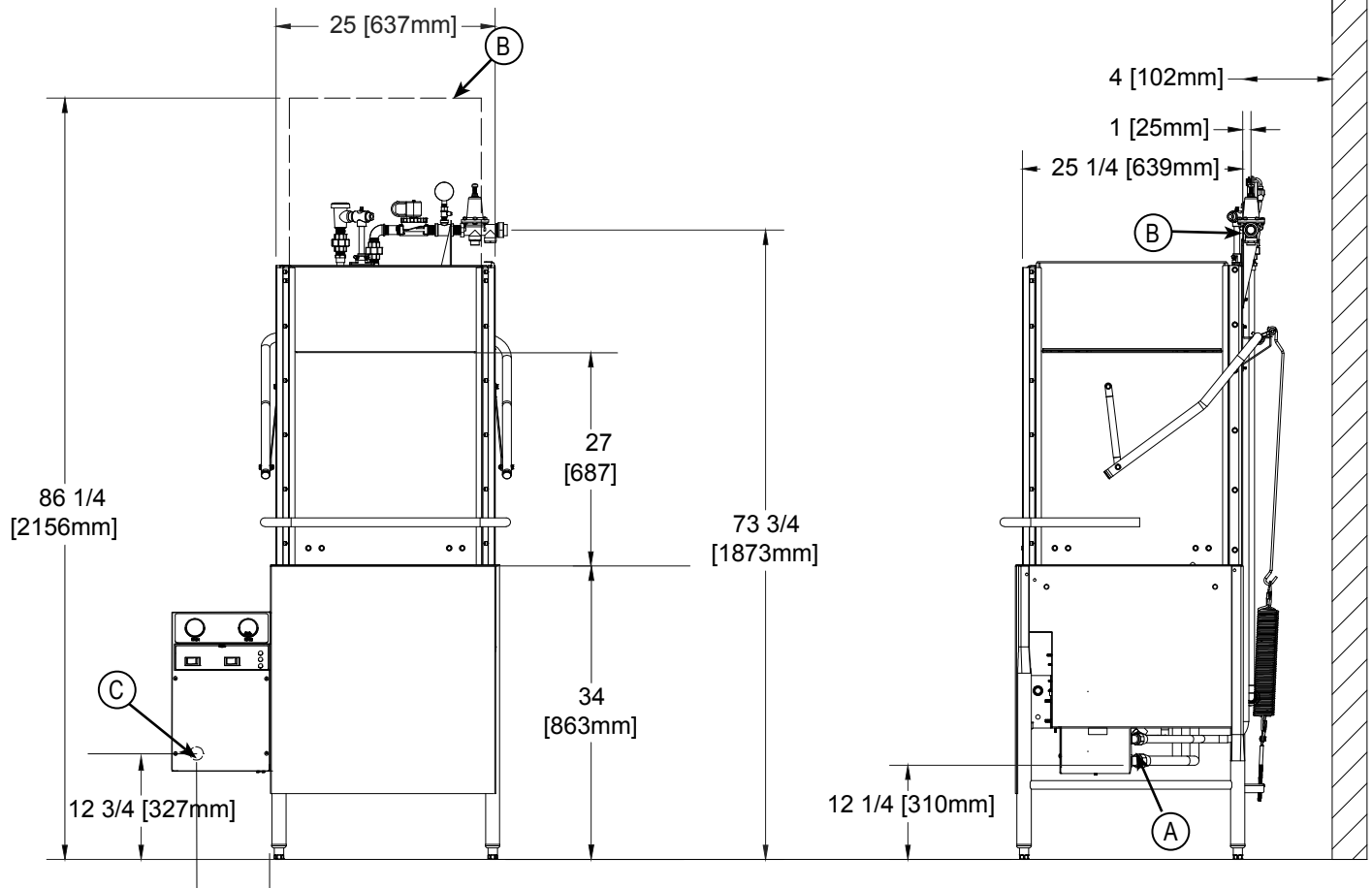
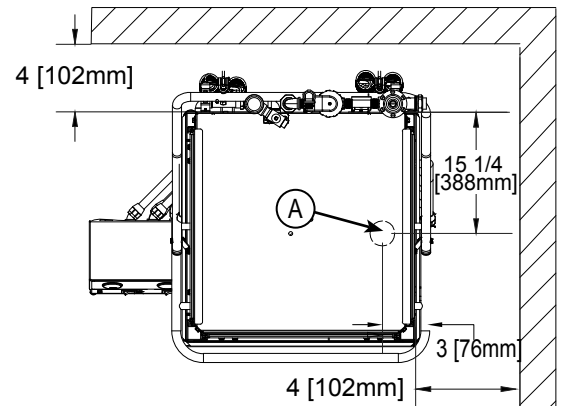

# SPECIFICATIONS

## DIMENSIONS (VENTLESS HEAT RECOVERY)

### LEGEND

- A) DRAIN  $\frac{1}{2}$  IPS
- B) WATER INLET  $\frac{3}{4}$  MIP
- C) ELECTRICAL CONNECTIONS

All vertical dimensions are  $\pm 1/2"$  due to adjustable bullet feet

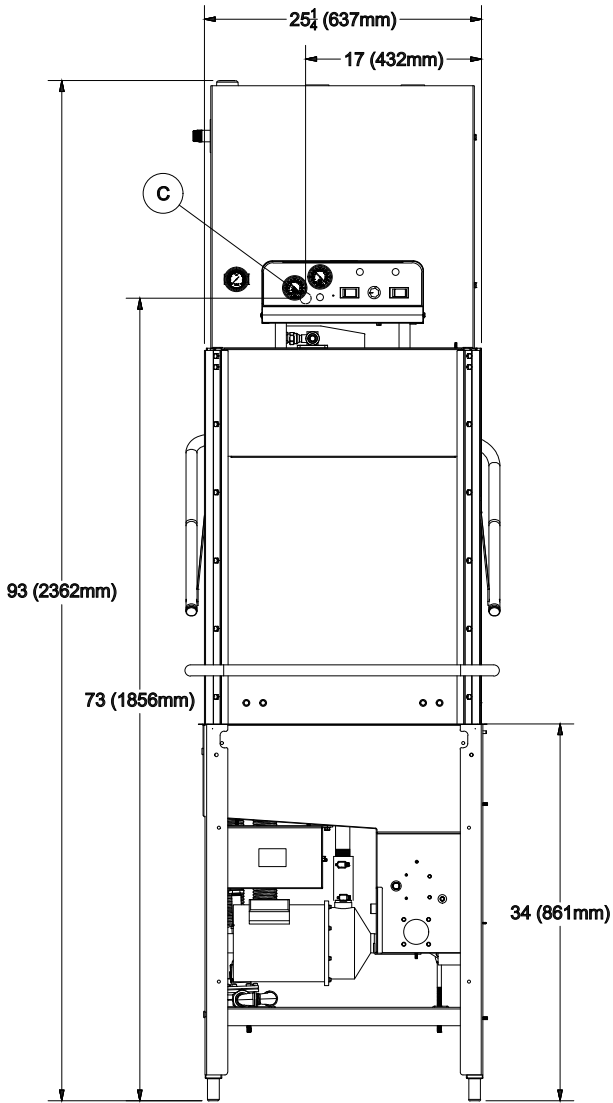
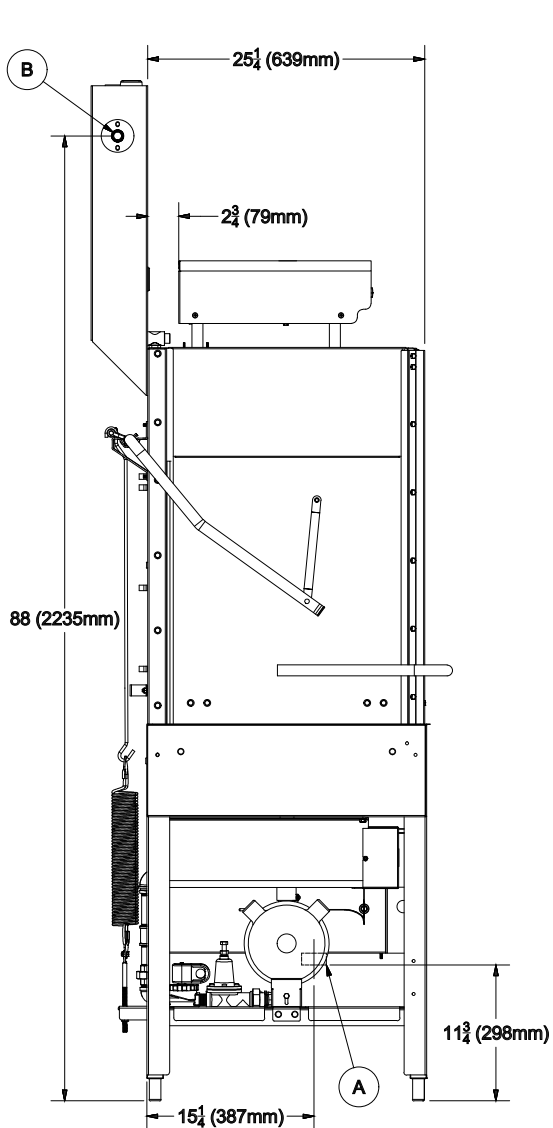
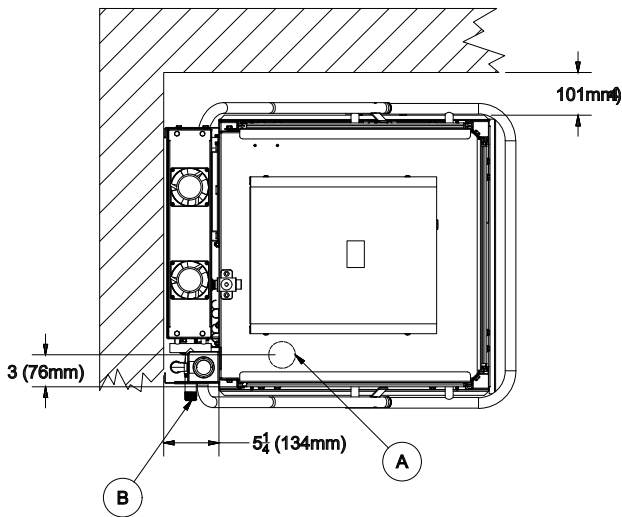

# SPECIFICATIONS

## TABLE DIMENSIONS

**NOTE:** Please remove the front dress panel from the dishmachine if mounting dishmachine for a corner installation and attaching side tables. Corner installation will trap panel making it difficult to remove.

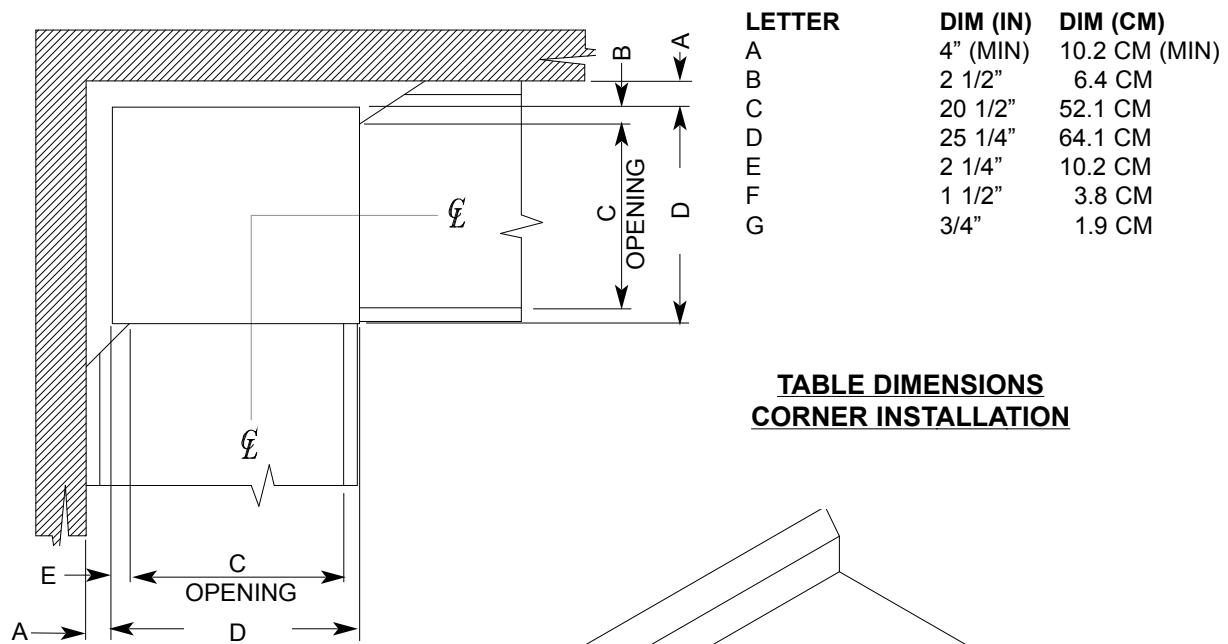

**TABLE DIMENSIONS  
CORNER INSTALLATION**

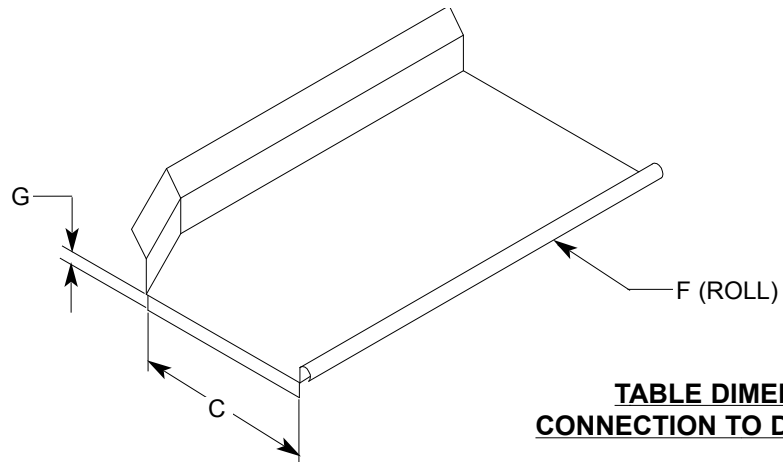

**TABLE DIMENSIONS  
CONNECTION TO DISHWASHER**

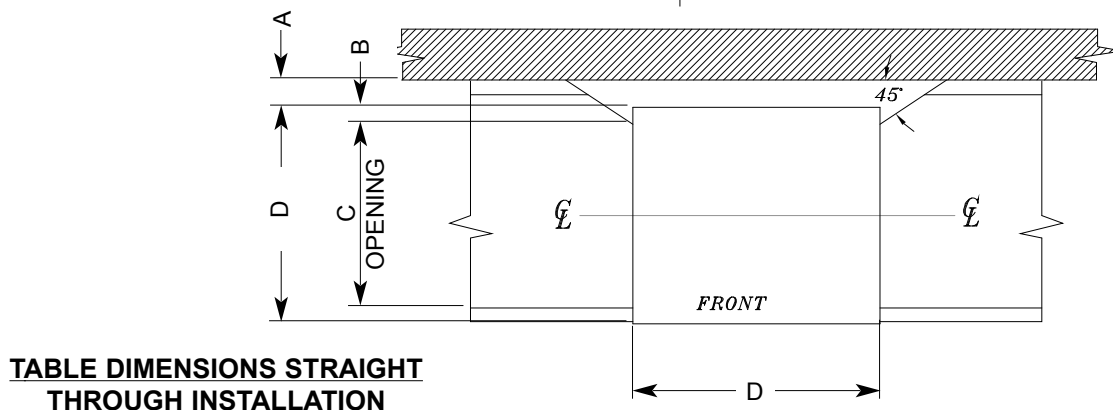

**TABLE DIMENSIONS STRAIGHT  
THROUGH INSTALLATION**

---

# INSTALLATION & OPERATION

## INSTALLATION INSTRUCTIONS

Jackson WWS Inc. provides technical support for all of the dishmachines detailed in this manual and recommends that service personnel have this manual on hand when calling technical support staff. Technical support is available from 8:00 a.m. to 5:00 p.m. (EST), Monday through Friday. Technical support is not available on holidays. Contact technical support toll free at 1-888-800-5672. Please remember that technical support is available for service personnel only.

**VISUAL INSPECTION:** Before installing unit check container and machine for damage. A damaged container may be an indication of damage to the machine. If there is any type of damage to both container and unit, do not throw away the container. The dishmachine has been inspected at the factory prior to shipping and is expected to arrive in new, undamaged condition. However, rough handling by carriers or others may result in damage to the unit while it is in transit. If such a situation occurs, do not return the unit to the manufacturer. Instead, contact the carrier and ask them to send a representative to the site to inspect the damage, and request that an inspection report be completed.

Contact the carrier within 48 hours of receiving the machine (to report possible freight damage) and the dealer from whom the unit was purchased.

**UNPACKING THE DISHMACHINE:** The machine should be unboxed and removed from the pallet prior to installing. Open the front door and remove all of the materials from the inside. Once unpacked, verify there are no missing parts. If a part is missing, contact manufacturer immediately.

**LEVEL THE DISHMACHINE:** The dishmachine is designed to operate while level. This is important to prevent any damage to the machine during operation and to ensure the best results possible. The unit comes equipped with adjustable bullet feet which can be turned using a pair of pliers. Verify the unit is level from front to back and side to side before making any electrical or plumbing connections.

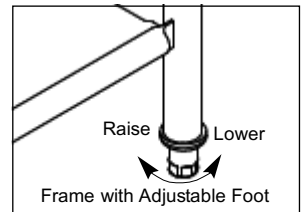

**PLUMBING THE DISHMACHINE:** All plumbing connections must be made to adhere to local, state, territorial and national codes. The installing plumber is responsible for ensuring the incoming water lines are flushed of debris prior to connecting to the machine. Note that chips and materials from cutting processes can become lodged in the solenoid valves and prevent them from opening or closing. Any valves that are found to be fouled or defective because of foreign matter left in the water line, and any subsequent water damage, are not the responsibility of the manufacturer.

A water hardness test must be performed to determine if the HTS-11 (scale prevention & corrosion control) needs to be installed. A hardness test kit can be found on the warning tag that is attached to the incoming plumbing connection on the back of the machine. If water hardness is higher than 5 GPG, the HTS-11 will need to be installed. Please contact manufacturer to purchase the HTS-11.

**CONNECTING THE DRAIN LINE:** The dishmachine's drain is a gravity discharge drain. All piping from the 1 1/2" FNPT connection on the wash tank must be pitched (1/4" per foot) to the floor or sink drain. All piping from the machine to the drain must be a minimum 1 1/2" I.P.S. and shall not be reduced. There must also be an air gap between the machine drain line and the floor sink or drain. If a grease trap is required by code, it should have a flow capacity of 5 gallons per minute.

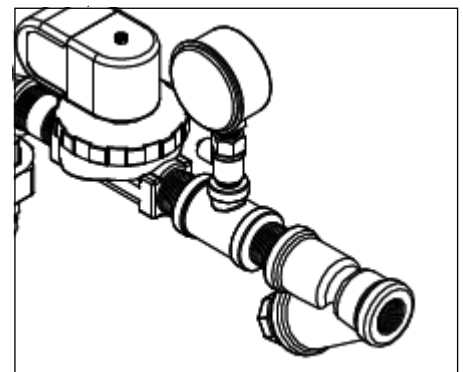

Incoming Plumbing Y-strainer Connection

# INSTALLATION & OPERATION

## INSTALLATION INSTRUCTIONS

**WATER SUPPLY CONNECTION:** Read the section entitled “PLUMBING THE DISHMACHINE” before proceeding. Install the water supply line (3/4” pipe size minimum, 1/2” pipe size minimum for LT) to the dishmachine line strainer using copper pipe. It is recommended that a water shut-off valve be installed in the water line between the main supply and the machine to allow access for service. The water supply line is to be capable of 20±5 PSI “flow” pressure at the recommended temperature indicated on the data plate. Take care not to confuse static pressure with flow pressure: Static pressure is line pressure in a “no flow” condition (all valves and services are closed); flow pressure is the pressure in the fill line when the valve is opened during the cycle. It is suggested that a shock absorber (not supplied) be installed on the incoming water line. This prevents water hammer (hydraulic shock)—induced by the solenoid valve as it operates—from causing damage to the equipment.

**PLUMBING CHECK:** Slowly turn on the water supply to the machine after the incoming fill line and the drain line have been installed. Check for any leaks and repair as required. All leaks must be repaired prior to placing the machine in operation.

**STEAM LINE CONNECTION:** The steam machines come with lines by which the source steam needs to be connected. Connect all steam lines to the machine as all applicable codes provide. See machine data plate for information concerning steam flow pressure.

**ELECTRICAL POWER CONNECTION:** Electrical and grounding connections must comply with the applicable portions of the National Electrical Code ANSI/NFPA 70 (latest edition) and/or other electrical codes. Disconnect electrical power supply and place a tag at the disconnect switch to indicate that you are working on the circuit. The dishmachine data plate is located on the right side and to the front of the machine. Refer to the data plate for machine operating requirements, machine voltage, total amperage load and serial number. To install the incoming power lines, open the control box. This will require taking a Phillips head screwdriver and removing the four (4) screws on the front cover of the control box. Install 3/4” conduit into the pre-punched holes in the back of the control box. Route power wires and connect to power block and grounding lug. Install the service wires (L1, L2, & L3 (three phase only)) to the appropriate terminals as they are marked on the terminal block. Install the grounding wire into the lug provided. Tighten the connections. It is recommended that “DE-OX” or another similar anti-oxidation agent be used on all power connections.

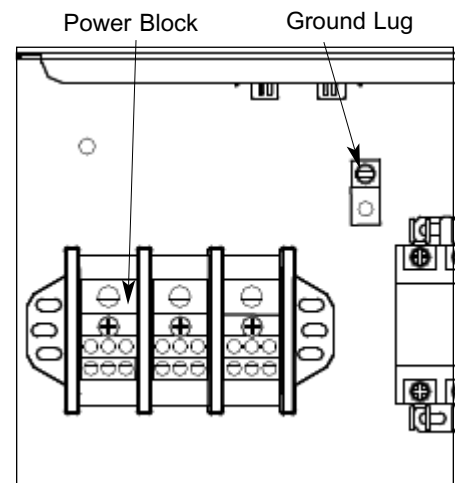

**VOLTAGE CHECK:** Ensure that the power switch is in the OFF position and apply power to the dishmachine. Check the incoming power at the terminal block and ensure it corresponds to the voltage listed on the data plate. If not, contact a qualified service agency to examine the problem. Do not run the dishmachine if the voltage is too high or too low. Shut off the service breaker and mark it as being for the dishmachine. Advise all proper personnel of any problems and of the location of the service breaker. Replace the control box cover and tighten down the screws.



---

# INSTALLATION & OPERATION

## VENTLESS HEAT RECOVERY MOUNTING INSTRUCTIONS

Due to shipping constraints the Tempstar High Hood is shipped disassembled, you should receive two pieces.

**1** Heat Recovery Unit

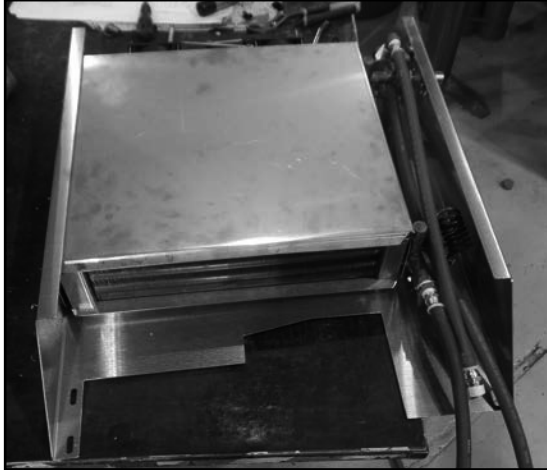

**2** Base Unit



*The heat recovery unit box is located inside the dishmachine shipping box.*

Fully Assembled Unit



# INSTALLATION & OPERATION

## VENTLESS HEAT RECOVERY MOUNTING INSTRUCTIONS

- 1 Locate and remove the four 1/4-20 bolts using a 7/16 wrench. These are located in top left and right corner of the unit.

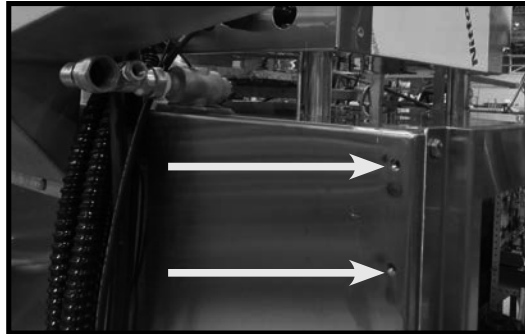

- 2 Lift the heat recovery unit up and over the lower air inlet, then align and slide unit onto the lower air inlet. Upper unit should slide inside the lower air inlet at the seam.



Lower Air Inlet Seam      Heat Recovery Unit



- 3 Reinstall the four 1/4-20 bolts that were removed in step 1 with a 7/16 wrench. They insert into the machine on the right and left corners.

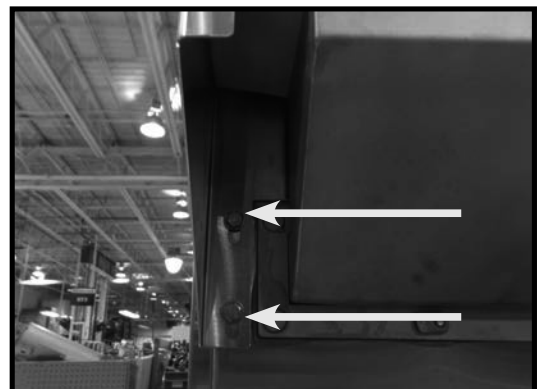
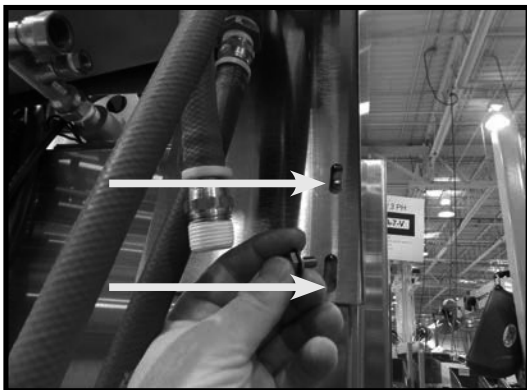

---

## INSTALLATION & OPERATION

### VENTLESS HEAT RECOVERY MOUNTING INSTRUCTIONS

- 4** Connect pressure gauge with a 9/16 wrench. Connect the two hoses using an adjustable wrench. The hoses are cut to length and will only reach their intended connection point.

A. Connect the Gauge



B. Final Rinse Inlet

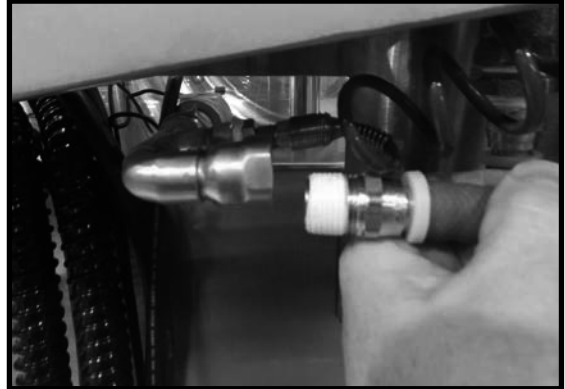

C. PRV Inlet from Coil



D. Booster Outlet

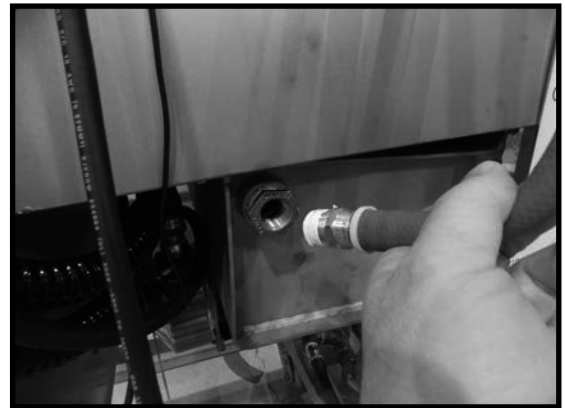

Before moving to the next step, tidy up the hoses by sliding them under the clamps. You may need to loosen the nut to accomplish this.



# INSTALLATION & OPERATION

## VENTLESS HEAT RECOVERY MOUNTING INSTRUCTIONS

- 5 Locate the wire connectors at the top of the unit and connect the white and black wires from the base unit.

Slide wire into the hole and push the lever down

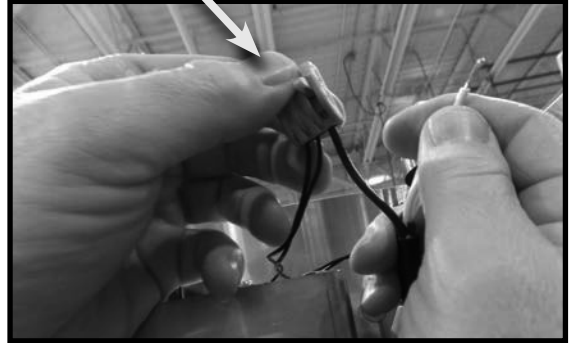

Tidy up the wires and lock them in place with the P-Clamp on the top of the unit.

P-Clamp

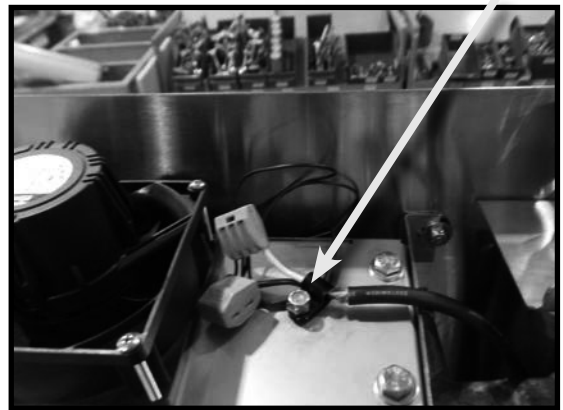
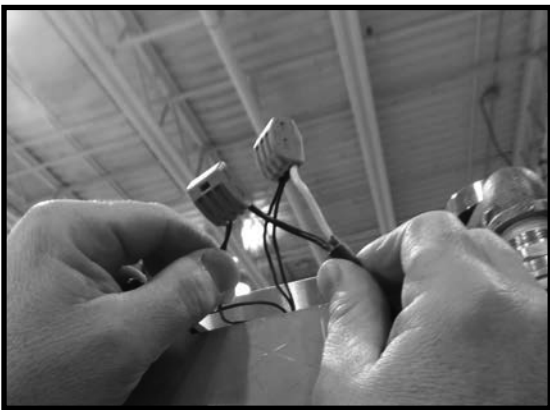

Now you have a fully assembled unit.



**PREPARATION:** Before proceeding with the start-up of the unit, verify the following:

- The pan strainer and pump suction strainer are clean and in place.
- The overflow tube and o-ring are installed.
- The wash and rinse arms are screwed securely into place, rotate freely and that their endcaps are tight.

**POWER UP:** To energize the unit, turn on the power at the service breaker. The voltage should have been previously verified as being correct. If not, the voltage must be verified before proceeding.

**FILLING THE WASH TUB:** For the initial fill, ensure that the cycle selection switch is in the “AUTO” (automatic) position, and place the power switch in the “ON” position. The unit will fill automatically and run through a rinse cycle. Open the door and verify that the water level is correct. Hereafter, the water level is controlled by the overflow tube. Verify that the drain stopper is preventing the wash tub water from draining excessively. There may be some slight leakage from the drain hole. Verify that there are no other leaks on the unit before proceeding any further. The wash tub must be completely filled before operating the wash pump to prevent damage to the component. Once the wash tub is filled, the unit is ready for operation.

**WARE PREPARATION:** Proper preparation of ware is essential for the smooth, efficient operation of your dishmachine. If done properly, you can expect to have fewer re-washes and use substantially less detergent. Any ware placed inside the machine should have all solid food waste and scraps removed. Pre-rinsing and pre-soaking are required, especially for silverware and casserole dishes. Place cups and glasses upside down in racks so that they do not hold water during the cycle. Load plates and saucers in the same direction, with the food surface facing the unload end of the machine.

**DAILY MACHINE PREPARATION:** Refer to the section entitled “PREPARATION” at the top of this page and follow the instructions there. Afterwards, check that all of the chemical levels are correct and/or that there is plenty of detergent available for the expected workload.

**WARM-UP CYCLES:** For a typical daily start-up, it is recommended to run the machine through 3 cycles to ensure that all of the cold water is out of the system and to verify that the unit is operating correctly. To cycle the machine, ensure that the power is on and the tub has filled to the correct level. Lift the door and the cycle light will illuminate. When the light goes out, close the door. The unit will start, run through a cycle and shut off automatically. Repeat this two more times. The unit is now ready to proceed with the washing of ware.

**WASHING A RACK OF WARE:** To wash a rack, open the door completely (beware of hot water dripping from the door) and slide the rack into the unit. Close the door and the unit will start automatically. Once the cycle is completed, open the door (again careful of the dripping hot water) and remove the rack of clean ware. Replace with a rack of soiled ware and close the door. The process will then repeat itself.

**OPERATIONAL INSPECTION:** Based upon usage, the pan strainer may become clogged with soil and debris as the workday progresses. Operators should regularly inspect the pan strainer to ensure it has not become clogged. If the strainer becomes clogged, it will reduce the washing capability of the machine. Instruct operators to clean out the pan strainer at regular intervals or as required by work load.

# INSTALLATION & OPERATION

---

## OPERATING INSTRUCTIONS

**STEAM FLOW:** Secure steam flow to the machine in accordance with applicable codes and procedures. Steam flow must be secured prior to cleaning the inside of the machine.

**SHUTDOWN AND CLEANING:** At the end of the workday, close the doors. When the unit completes the cycle, turn the power switch to the OFF position and open the door. Remove and clean the pan strainer. Remove the drain stopper from the tub and allow the tub to drain (NOTE: The wash tank water will be hot so caution is advised). Once the wash tub is drained, remove the pump suction strainer. Dispose of any soil and debris found in the strainer. Unscrew the wash and rinse arms from their manifolds. Remove the endcaps and flush the arms with water. Use a brush to clean out the inside of the arms. If the nozzles appear to be clogged, use a toothpick to remove the obstruction. Wipe the inside of the unit, removing all soil and scraps. Reassemble the wash and rinse arms and replace them in the unit. The arms only need to be hand tight, do not use tools to tighten them down. Reinstall the drain stopper and strainers and close the door.

**WATER CONSUMPTION ISSUES AND EFFICIENCY:** The models covered in this manual provide the customer with the ability to control the hourly rack capacity of the machine. Extending the wash cycle to wash severely soiled ware, such as mixing bowls, does not increase the machine's water consumption. However, selecting a longer time cycle does lower the amount of dishes the machine will be able to wash per hour. It is important for operators to select the correct wash cycle depending on the amount of washing required. Not every rack of dishes requires the machine to be set on the longest wash cycle.

**DETERGENT CONTROL:** Detergent usage and water hardness are two factors that contribute greatly to how efficiently this dishmachine will operate. Using detergent in the proper amount can become a source of substantial savings. A qualified water treatment specialist can relate what is needed for maximum efficiency from the detergent.

1. Hard water greatly affects the performance of the dishmachine, causing the amount of detergent required for washing to increase. If the machine is installed in an area with hard water, the manufacturer recommends the installation of water treatment equipment.
2. Deposited solids from hard water can cause spotting that will not be removed with a drying agent. Treated water will reduce this occurrence.
3. Treated water may not be suitable for use in other areas of operation and it may be necessary to install a water treatment unit for the water going to the dishmachine only. Discuss this option with a qualified water treatment specialist.
4. Dishmachine operators should be properly trained in how much detergent is to be used per cycle. Meet with a water treatment specialist and detergent vendor to discuss a complete training program for operators.
5. Certain dishmachine models require that chemicals be provided for proper operation and sanitization. Some models may require the installation of third-party chemical feeders to introduce those chemicals to the machine. The manufacturer does not recommend or endorse any brand name of chemicals or chemical dispensing equipment. Contact a chemical distributor for questions.
6. Some dishmachines come equipped with integral solid detergent dispensers. These dispensers are designed to accommodate detergents in a certain-sized container. If applicable, relate this to a chemical distributor upon first contacting them.
7. Water temperature is an important factor in ensuring that the dishmachine functions properly, and the machine's data plate details what the minimum temperatures must be for the incoming water supply, the wash tank and the rinse tank. If minimum requirements are not met, there is a possibility that dishes will not be clean or sanitized.
8. Instruct dishmachine operators to observe the required temperatures and to report when they fall below the minimum allowed. A loss of temperature can indicate a larger problem—such as a failed heater—or could indicate that the hot water heater for the operation is not up to capacity and a larger one may need to be installed.

# INSTALLATION & OPERATION

## FALSE PANEL INSTRUCTIONS

False Panel  
05700-002-52-54

Kit, False Panel with  
Mounting Hardware  
05700-002-52-89

Rack rail removed and  
repositioned for a  
corner operation.

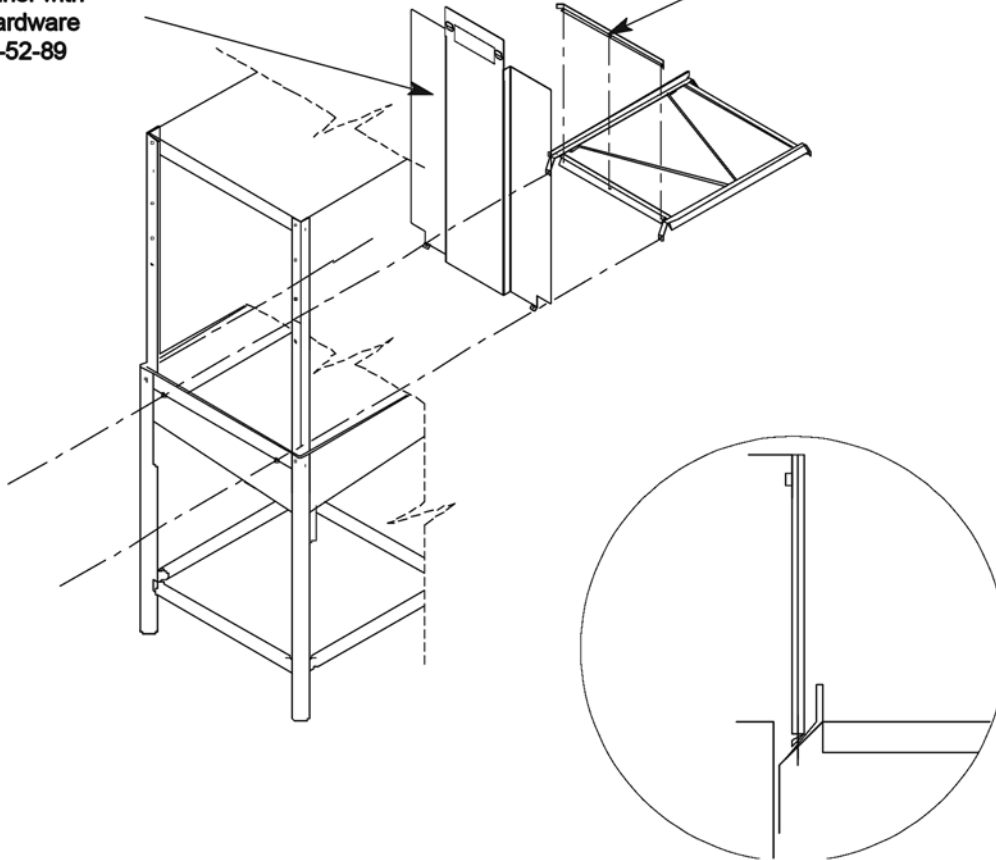

False panel positioned in unit

Insert this  
side first.

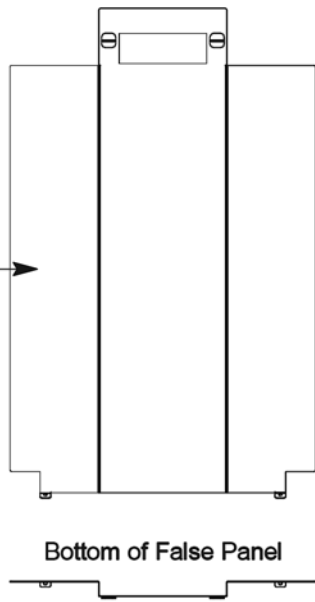

Bottom of False Panel

1. Remove the rack assembly from the dishmachine.
2. The false panel will mount inside of the dishmachine.
3. Position the panel in the dishmachine on the side to be closed.
4. Hold the panel against the side of the dishmachine and push upward.
5. The panel will clip in at the top, inside of the unit.
6. The holes in the false panel will line up with the rack assembly holes.
7. Reinstall the screws for the rack assembly which will secure the false panel to the unit.
8. Reassemble the rack track in an "L" shape for a corner operation.



Jackson highly recommends that any maintenance and repairs not specifically discussed in this manual should be performed by QUALIFIED SERVICE PERSONNEL ONLY (see qualified service agencies in the back of this manual). Performing maintenance on your dishmachine may void your warranty if it is still in effect. By following the operating and cleaning instructions in this manual, users should get the most efficient results from the dishmachine.

Steps to ensure that the dishmachine is used properly:

1. Ensure that the water temperatures match those listed on the machine data plate (on the front left of machine).
2. Remove as much soil as possible from dishes before loading into racks.
3. Ensure that all strainers are in place, laying flat in tub and free of soil and debris before operating the machine. To clean strainers, wipe them out with a rag and rinse under a faucet. For stubborn debris, a toothpick can be used to dislodge any obstructions from the perforations. Do not beat strainers on waste cans; once bent they will not work properly.
4. If hard water is present, install an HTS-11 into the water line connecting to the dishmachine (see section "Plumbing the Dishmachine").
5. Ensure that all wash and/or rinse arms are secure in the machine before operating.
6. Ensure that drains are closed/sealed before operating.
7. Do not overfill racks.
8. Ensure that glasses are placed upside down in the rack.
9. Ensure that all chemicals being injected into machine have been verified as being at the correct concentrations.
9. Clean out the machine at the end of every workday as per the instructions in the manual (see section on "Shutdown & Cleaning").
10. Always contact a qualified service agency whenever a serious problem arises.
11. Follow all safety procedures, whether listed in this manual or put forth by local, state or national codes/regulations.

## TROUBLESHOOTING

PROBLEM	POSSIBLE CAUSE	REMEDY
Dishmachine runs continuously in the wash cycle.	<p>Machine is in delime mode.</p> <p>Wash cycle delay timer is faulty.</p> <p>Wash cycle delay timer settings are not correctly adjusted.</p> <p>Cam timer is faulty.</p>	<p>Change operation mode from DELIME to NORMAL position.</p> <p>During the wash cycle, the cam timer will move for the first 30 seconds of the wash cycle. The cycle delay timer will then cause the cam timer to stop, in order to increase the length of the wash cycle. The red light on the delay timer is in control of the cam timer. If the red light is not turning on (only during cycles B, C or D), replace the cycle timer.</p> <p>If the wash cycle delay timer and rotating cam timer are working correctly, the time cycles on the delay timer may be incorrectly adjusted. Adjust the delay potentiometer corresponding to the B, C or D cycle. Rerun the appropriate cycle and see if the adjustment has made any change in the length of the cycle. If not, replace the cycle delay timer.</p> <p>Confirm that the wash cycle delay timer is functioning correctly (see above). Confirm that the timer motor is receiving power. If it is, replace the motor and/or timer assembly. Make sure there are no obstructions which limit the rotation of the cam timer.</p>
Dishmachine will not fill after the door is closed. <u>Power "ON" light is illuminated.</u>	<p>Faulty rinse solenoid valve.</p> <p>Faulty door switch.</p> <p>Fouled/faulty high level probe.</p>	<p>Repair or replace valve as required.</p> <p>Verify the wiring of the switch; if correct, replace the switch.</p> <p>Clean probe if fouled. If clean and not working, replace.</p>
Dishmachine will not fill after the door is closed. <u>Power "ON" light is not illuminated.</u>	<p>Service breaker tripped.</p> <p>Machine not connected to power source.</p> <p>Faulty power source.</p>	<p>Reset. If the breaker trips again, contact an electrician to verify the amp draw of the machine.</p> <p>Verify that the machine has been properly connected to the power source.</p> <p>Verify the wiring of the switch; if correct, replace switch.</p>
Dishmachine will not fill after the door is closed. <u>Power "ON" light is not illuminated.</u>	<p>Service breaker tripped.</p> <p>Machine not connected to power source.</p> <p>Faulty power source.</p>	<p>Reset. If the breaker trips again, contact an electrician to verify the amp draw of the machine.</p> <p>Verify that the machine has been properly connected to the power source.</p> <p>Verify the wiring of the switch; if correct, replace switch.</p>
Wash or rinse heater does not work.	<p>Faulty heater element.</p> <p>Faulty heater contactor.</p> <p>Misadjusted/faulty thermostat(s).</p>	<p>Check element for continuity; if open, replace the heater.</p> <p>Replace the contactor.</p> <p>Verify the operation and setting of thermostats; replace if necessary.</p>
Dishmachine fills slowly and/or rinse is weak.	<p>Clogged or obstructed rinse arms.</p> <p>Low incoming water pressure.</p> <p>Y-strainer is clogged.</p>	<p>Remove and clean the rinse arms.</p> <p>Adjust the water pressure regulator to ensure that there is 20±5 PSI flow.</p> <p>Clean out the Y-strainer.</p>
Rinse water is not reaching required temperature.	<p>Faulty rinse heater.</p> <p>Misadjusted/faulty thermostat(s).</p> <p>Rinse thermometer is defective.</p>	<p>Check element for continuity; if open, replace heater.</p> <p>Verify operation and setting of thermostats; replace if necessary.</p> <p>Replace thermometer.</p>

PROBLEM	POSSIBLE CAUSE	REMEDY
Wash water is not reaching required temperature.	Faulty wash heater.	Check element for continuity; if open, replace heater.
	Misadjusted/faulty thermostat(s).	Verify operation and setting of thermostats; replace if necessary.
	Wash thermometer is defective.	Replace thermometer.
Doors will not close completely.	Improper spring tension.	Adjust spring tension as required by loosening (not removing) spring bolt nuts and adjusting the tension. Tighten nuts back when done.
	Obstruction in door channel.	Remove the obstruction.
	Doors are not square with frame.	Adjust the frame to accommodate the doors.
Water leaks at the wash pump.	Wash pump seal defective.	Replace the seal.
	Petcock or pump drain (if equipped) not shut/tight.	Close or tighten.
	Loose hoses (hose clamps) on the wash pump.	Tighten the hose clamps.
Will not rinse during autcycle.	Defective rinse solenoid.	Repair or replace the rinse solenoid as required.
	Faulty fill microswitch.	Replace microswitch.
	No water to the machine.	Verify that there is water at 20±5 PSI connected to the machine.
Dishes are not coming clean.	Machine temperatures are not up to the minimum requirements.	Verify that incoming water, rinse water and wash water match the required temperatures as listed on the machine data plate.
	No detergent/too much detergent.	Adjust detergent concentration as required for the amount of water held by the machine.
	Solid dispenser canister is empty.	Replace the canister.

# PARTS

## TOP MOUNTED CONTROL BOX ASSEMBLY

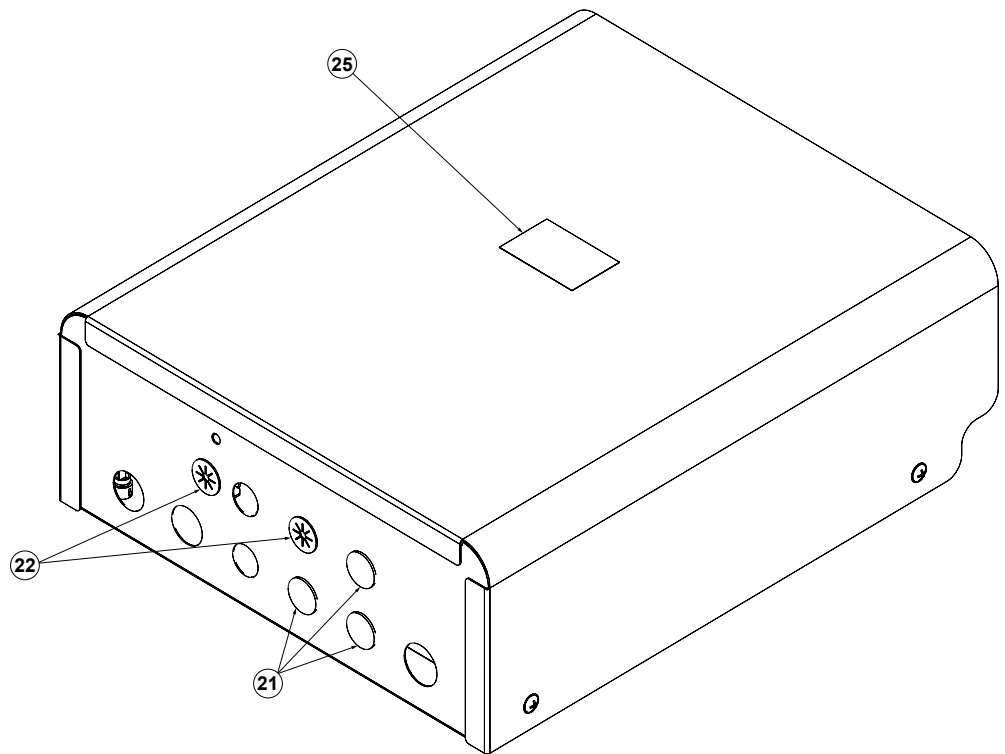
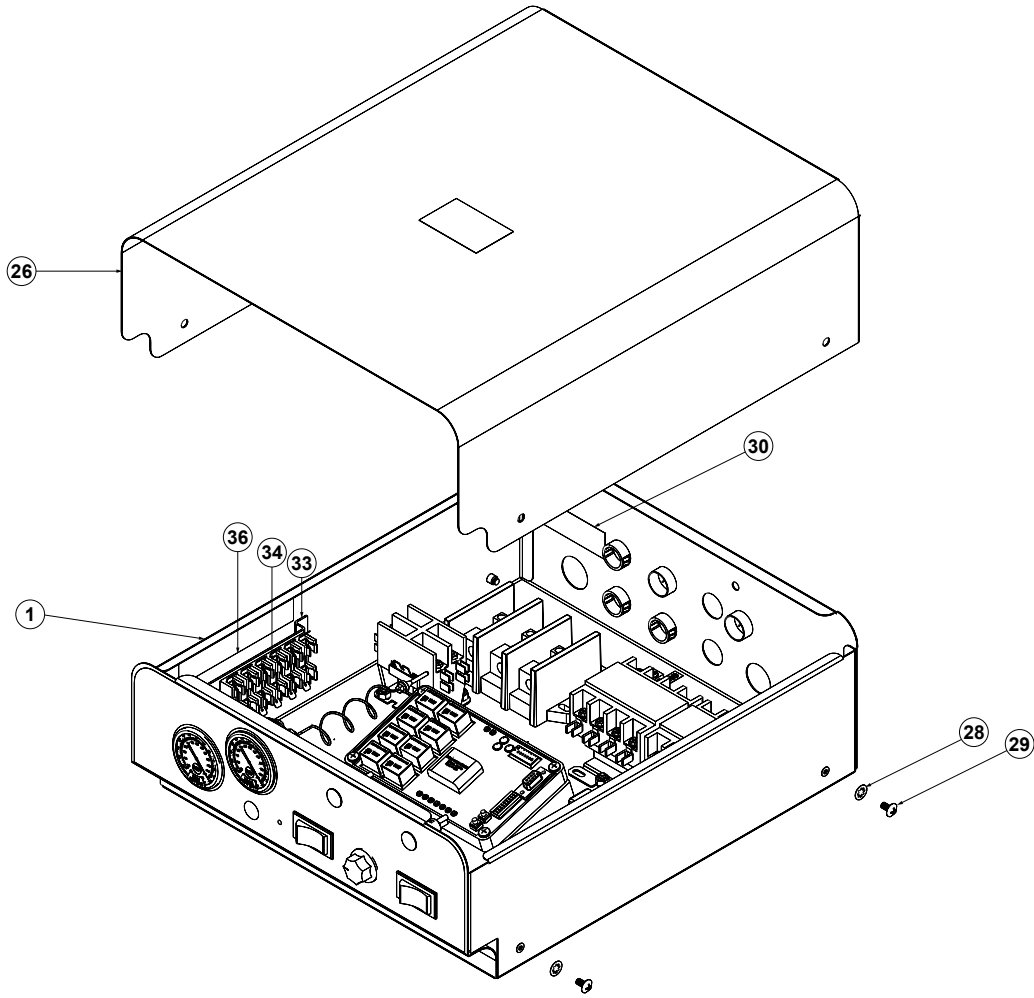

*TOP MOUNTED CONTROL BOX ASSEMBLY (CONTINUED)*

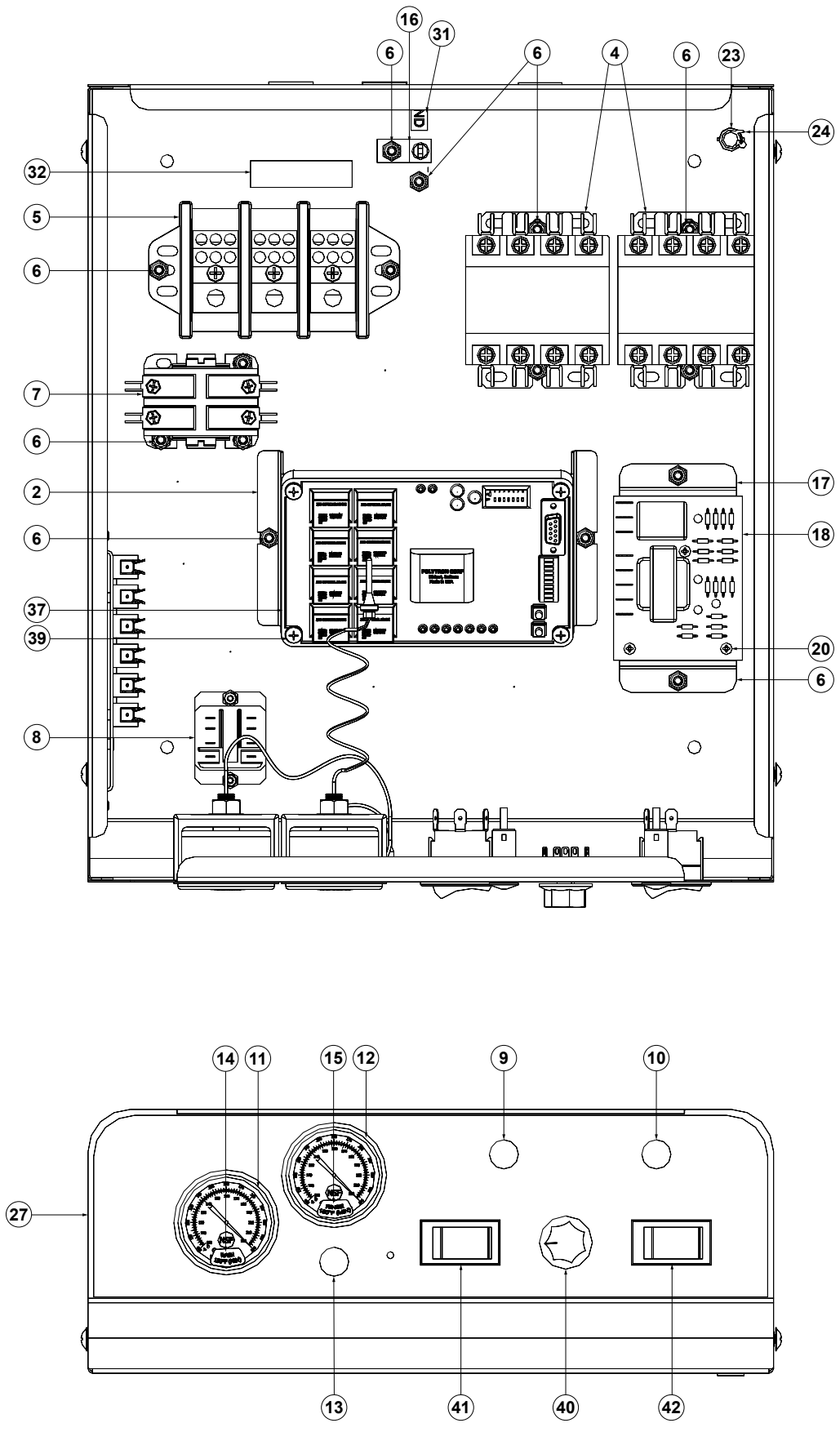

**PARTS****TOP MOUNTED CONTROL BOX ASSEMBLY (CONTINUED)**

ITEM	QTY	DESCRIPTION	PART NUMBER
1	1	Control Box Weldment	05700-003-30-14
2	1	Timer Bracket	05700-003-02-08
3	2	Lock Nut 6-32	05310-373-03-00
4*	2	Heater Contactor	05945-109-01-69
5	1	Terminal Block	05940-011-48-27
6	17	Lock Nut 10-24	05310-373-01-00
7	1	Contactora, Wash Motor	05945-002-74-20
8	1	Relay	05945-111-47-51
	1	Relay (415V, 3PH, 5 Wire Only)	05945-111-89-75
9	1	Light, Green	05945-111-44-43
10	1	Light, Red	05945-111-44-45
11	1	Temperature Gauge, Wash 96" Lead	06685-111-68-49
12	1	Temperature Gauge, Rinse 48" Lead	06685-111-68-48
13	1	Light, Yellow	05945-111-44-44
14	1	Decal, Wash 150°F Min	09905-002-97-61
15	1	Decal, Rinse 180°F Min	09905-002-97-62
16	1	Ground Lug	05940-200-76-00
17	1	Bracket, Liquid Level Control Board	05700-002-13-22
18	1	Liquid Level Control Board	06680-200-08-21
19	6	Tricnut, 6-32	05340-118-04-00
20	3	Screw, 6-32 x 5/8"	05305-011-39-85
21	3	Plug, 1/2"	05975-011-47-81
22	2	Grommet, 7/8" Split	05975-200-40-00
23	1	Bushing Snap	05975-210-02-00
24	1	Clamp, Hose .25-.312	05975-002-61-43
25	1	Decal, Warning-Disconnect Power	09905-100-75-93
26	1	Cover, Top Mount Control Box	05700-002-23-03
27	1	Decal, Control Box	09905-003-97-38
28	4	Lockwasher, Int. Tooth #10	05311-273-03-00
29	4	Screw, 10-32 x 3/8" Phillips Truss Head	05305-173-12-00
30	1	Decal, Copper Conductors	09905-011-47-35
31	1	Decal, Ground	09905-011-86-86
32	1	Decal, L1, L2	09905-002-78-67
33	1	Bracket, Fuse Strip	05700-002-42-03

**TOP MOUNTED CONTROL BOX ASSEMBLY (CONTINUED)**

<b>ITEM</b>	<b>QTY</b>	<b>DESCRIPTION</b>	<b>PART NUMBER</b>
34	1	Fuse Holder, 6 Pole	05920-002-42-13
35	2	Screw, 6-32 x 3/8" with Ext. Tooth Washer	05305-002-25-91
36	1	Decal, Dispenser Connection	09905-003-34-09
37	1	Timer, Universal	05945-003-33-09
		Timer, Universal Fused (Alternate)	05945-003-75-23
38	4	Locknut, 10-32	05310-373-02-00
39	4	Screw 10-32 x 1"	05305-002-19-42
40	1	Switch, Rotary Selector	05930-003-97-61
41	1	Switch, Operation	05930-301-53-00
42	1	Switch, Power	05930-011-49-55
43*	1	Overload, TK-ONLY (460 Volt Unit Only)	05945-002-65-02
44*	1	Motor Contactor, SC-03Y (460 Volt Unit Only)	05945-002-65-00
45*	1	Din Rail 2-3/4" (460 Volt Unit Only)	05700-001-84-65

**\*For a 460V Unit, replace item 4 with items 43, 44 & 45.**

# PARTS

## SIDE MOUNT UNIVERSAL TIMER CONTROL BOX ASSEMBLY

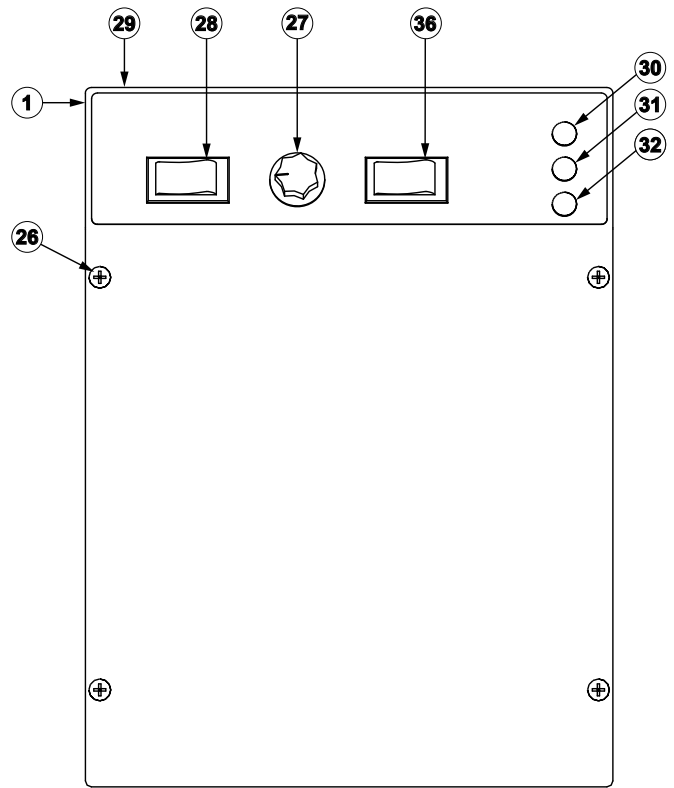
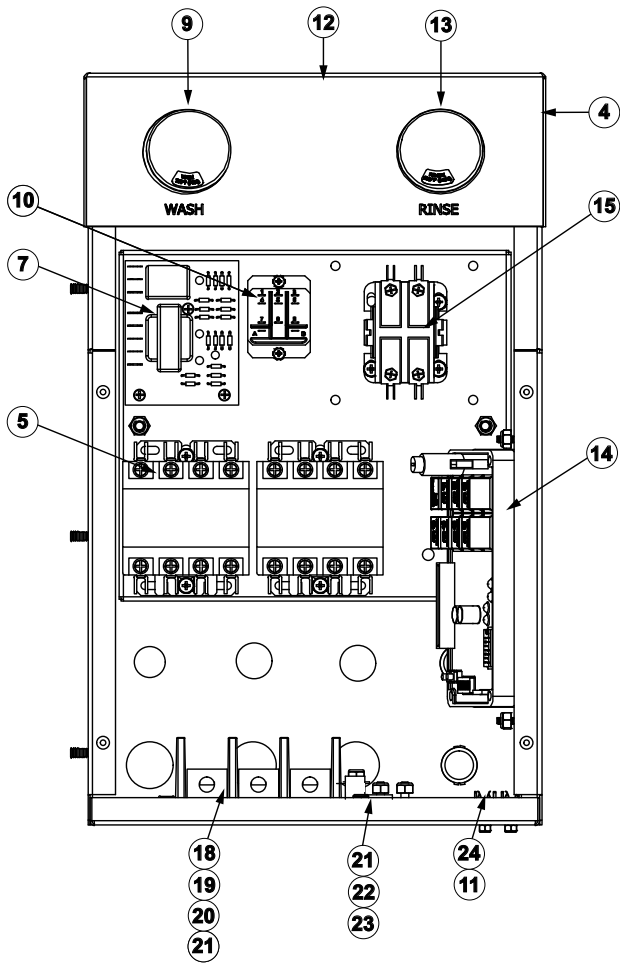
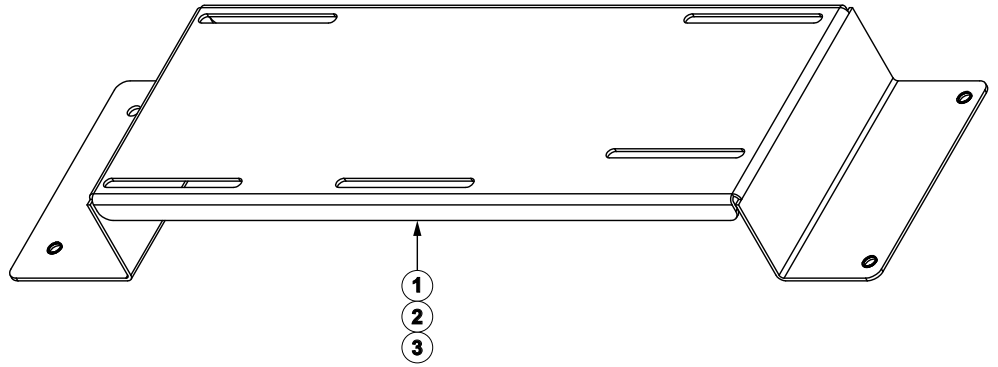



**SIDE MOUNT UNIVERSAL TIMER CONTROL BOX ASSEMBLY (CONTINUED)**

<b>ITEM</b>	<b>QTY</b>	<b>DESCRIPTION</b>	<b>PART NUMBER</b>
1	1	Bracket, Electrical Box Mounting	05700-002-18-48
2	9	Locknut, 1/4"-20 S/S Hex with Nylon Insert	05310-374-01-00
3	9	Washer, 1/4"-20 I.D. S/S	05311-174-01-00
4	1	Control Box Weldment, Right Hand	05700-002-06-48
	1	Control Box Weldment, Left Hand	05700-002-23-08
5	2 1	Contactora, 4 Pole, 220V, 1 Phase No Booster, Steam Models and LT	05945-109-01-69
6	4	Screw, 10-32 x 1/2" Phillips Pan Head with Washer	05305-002-32-37
7	1	Liquid Level Control	06680-200-08-21
8	3	Screw, 6-32 x 5/8"	05305-011-39-85
9	1	Thermometer, 48 Lead, Wash	06685-111-68-48
	1	Decal, Wash 150°F	09905-002-97-61
	1	Decal, 120°F Wash/Rinse (not shown) (LT only)	09905-002-82-46
10	1	Relay, 240V, 50/60Hz, Top Mount	05945-002-47-74
11	8	Screw, 6-32 x 3/8" SEMS with External Tooth Washer	05305-002-25-91
12	1	Decal, Control Box Gauge	09905-002-10-69
13	1	Thermometer, 96 Lead Rinse	06685-111-68-49
	1	Decal, Rinse 180°F	09905-002-97-62
	1	Decal, 120°F Wash/Rinse (not shown) (LT only)	09905-002-82-46
14	1	Timer, Universal	05945-003-75-23
15	1	Timer, Bracket	05700-003-02-08
	6	Holder, Keystone	05940-002-21-87
	1	Keying Plug	05940-003-11-66
	2	Connector	05940-003-11-65
16	1	Contactora, 2 Pole, 220V, 20 Amp (208-230V Unit only)	05945-002-74-20
17	1	Timer, Cycle Delay (not used with Universal Timer or LT) (not shown)	05945-002-13-78
18	1	Terminal Block, 3 Pole	05940-011-48-27
19	1	Decal, L1, L2, L3	09905-101-12-66
20	1	Decal, Copper Conductors	09905-011-47-35
21	4	Locknut, 10-24 S/S Hex with Nylon Insert	05310-373-01-00
22	1	Wire Lug	05740-200-76-00
23	1	Decal, Ground	09905-011-86-86
24	1	Holder, Fuse	05920-401-03-14

**PARTS****SIDE MOUNT CONTROL BOX ASSEMBLY (CONTINUED)**

<b>ITEM</b>	<b>QTY</b>	<b>DESCRIPTION</b>	<b>PART NUMBER</b>
25	1	Cover, Control Box Weldment	05700-002-06-52
		Cover, Control Box Weldment (not shown) (LT)	05700-004-22-50
26	4	Bolt, 10-32 x 1/2" Slotted Truss	05305-173-04-00
27	1	Switch, Rotary Selector - Not on LT	05930-003-97-61
28	1	Switch, Operation	05930-301-53-00
29	1	Decal, Control Box Cover	09905-003-97-39
	1	Decal, Control Box Cover (LT ONLY) (not shown)	09905-004-22-33
30	1	Light, Red	05945-504-07-18
31	1	Light, Green Indicator	05945-504-08-18
32	1	Light, Amber	05945-504-06-18
33	1	Cover, Dielectric Control Panel (not shown)	05700-021-50-89
34	1	Contactora, 2 Pole, 220V, 20 Amp (460V Unit Only)	05945-002-65-00
35	1	Overload (460V Unit Only)	05945-002-65-01
36	1	Switch, Power	05930-011-49-55

**SIDE MOUNT MECHANICAL TIMER CONTROL BOX**

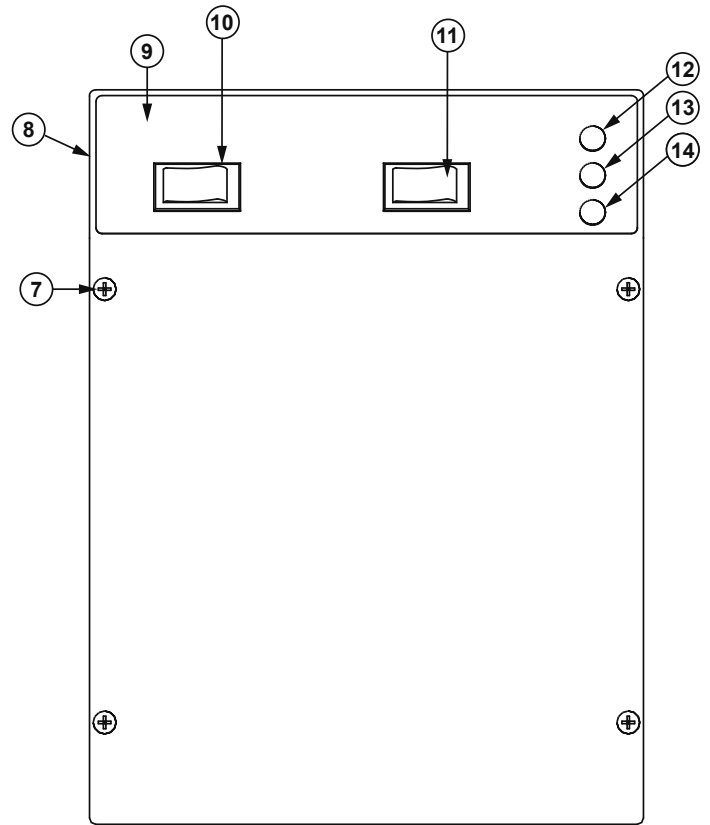
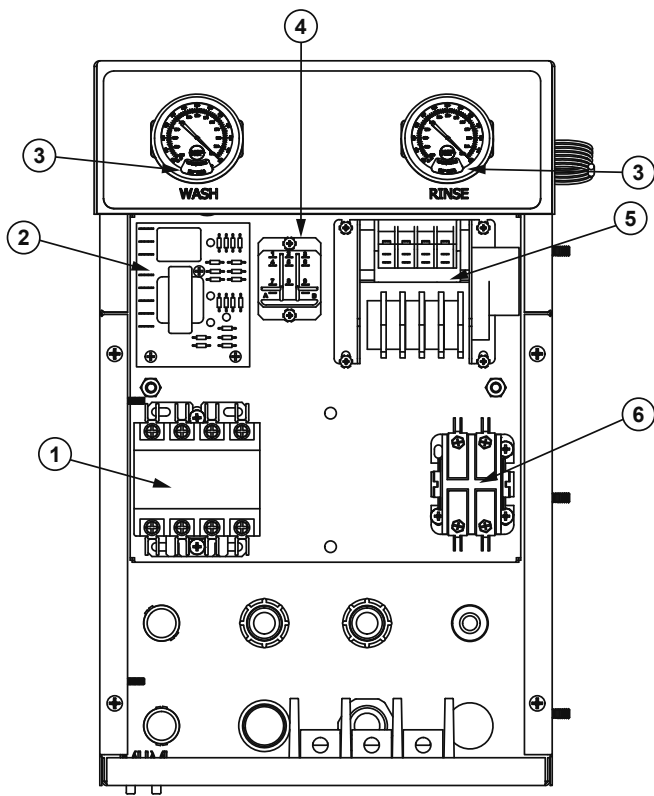

ITEM	QTY	DESCRIPTION	PART NUMBER
1	2 1	Contactors, 4 Pole, 220V, 1 Phase No Booster, Steam Models and LT	05945-109-01-69
2	1	Liquid Level Control	06680-200-08-21
3	1	Decal, 120°F Wash/Rinse (not shown) (LT only)	09905-002-82-46
4	1	Relay, 240V, 50/60Hz, Top Mount	05945-002-47-74
5	1	Timer, Cam/Mechanical	05945-303-31-00
6	1	Contactors, 2 Pole, 220V, 20 Amp (208-230V Unit only)	05945-002-74-20
7	4	Bolt, 10-32 x 1/2" Slotted Truss	05305-173-04-00
8	1	Bracket, Electrical Box Mounting	05700-002-18-48
9	1	Decal, Control Box Cover	09905-003-97-39
10	1	Switch, Operation	05930-301-53-00
11	1	Switch, Power	05930-011-49-55
12	1	Light, Red	05945-504-07-18
13	1	Light, Green Indicator	05945-504-08-18
14	1	Light, Amber	05945-504-06-18

**PARTS**  
HOOD ASSEMBLY

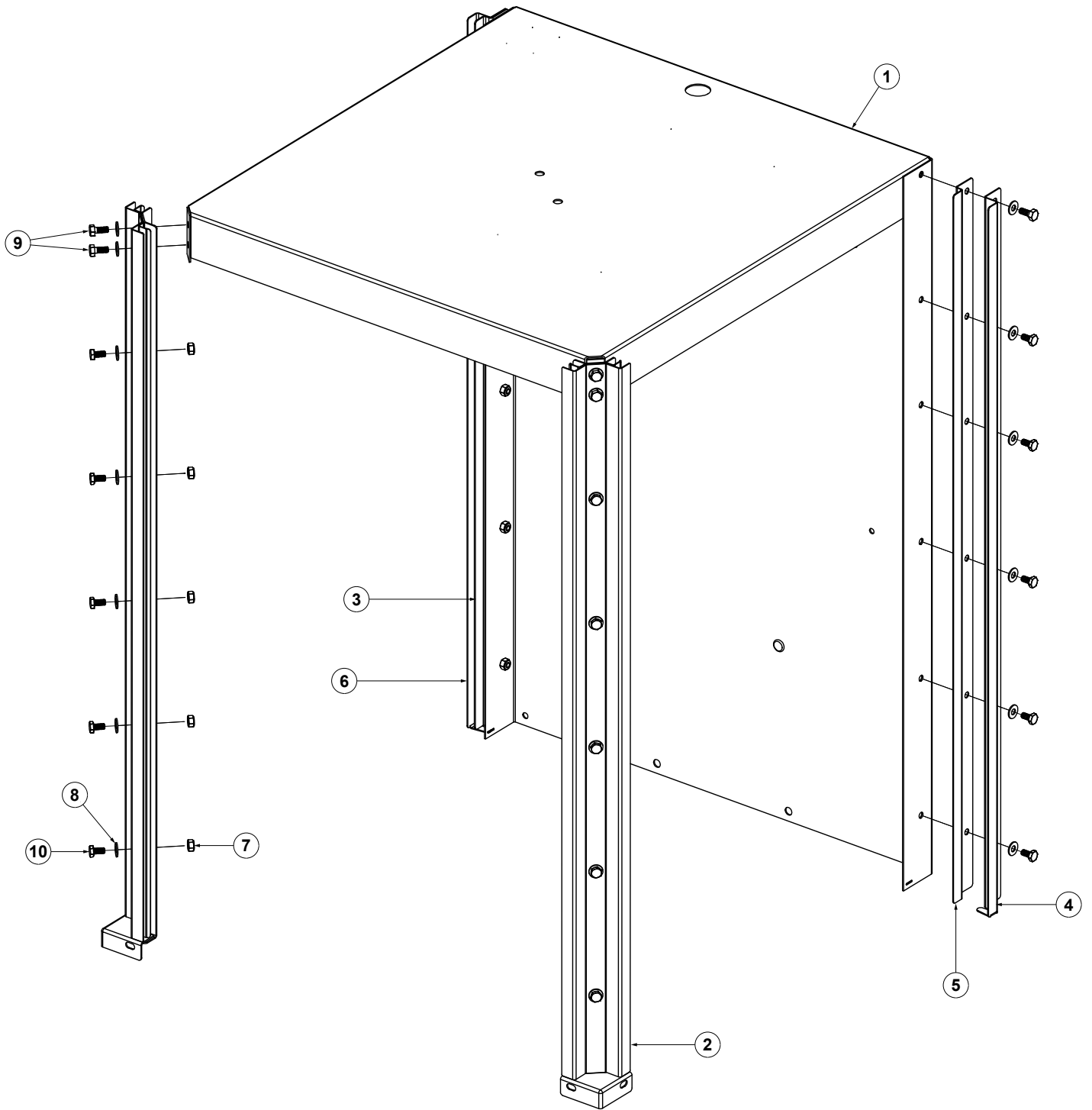

<b>ITEM</b>	<b>QTY</b>	<b>DESCRIPTION</b>	<b>PART NUMBER</b>
1	1	Hood Weldment	05700-003-05-67
2	2	Hood Support Assembly	05700-004-13-45
3	1	Left Back Inner Door Guide	05700-031-76-34
4	1	Right Back Outer Door Guide	05700-031-76-32
5	1	Right Back Inner Door Guide	05700-031-76-35
6	1	Left Back Outer Door Guide	05700-031-76-33
7	34	Locknut, 1/4-20 Hex w/Nylon Insert	05310-374-01-00
8	26	Washer, S/S 1/4-20 I.D.	05311-174-01-00
9	6	Screw, 1/4-20 x 5/8 S/S Hex Head	05305-274-24-00
10	20	Bolt, 1/4-20 x 1/2 Long	05305-274-02-00

# PARTS

## CANTILEVER ARM/DOOR ASSEMBLIES

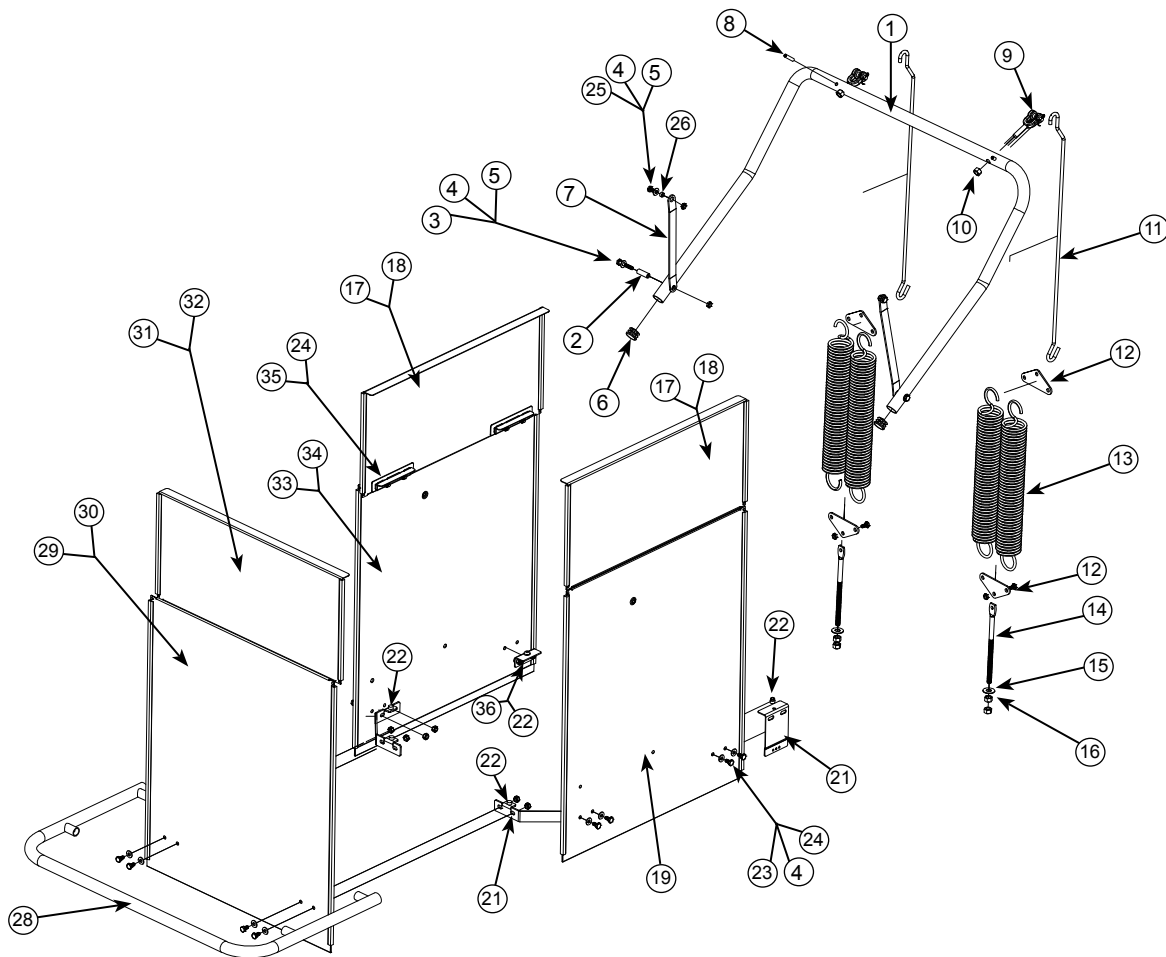

ITEM	QTY	DESCRIPTION	PART NUMBER
1	1	Cantilever Arm	05700-004-14-29
2	2	Sleeve, Cantilever Arm	05700-000-85-69
3	2	Screw, 1/4"-20 x 1 1/2" Long Hex Head	05305-274-23-00
4	4	Washer, 1/4" I.D. S/S	05311-174-01-00
5	4	Locknut, 1/4"-20 S/S Low Profile with Nylon Insert	05310-374-02-00
6	4	Plug, Cantilever	05340-011-35-00
7	2	Connecting Link	05700-021-92-45
8	2	Spring Pin, 1/4" x 1 1/8" Long	05315-407-06-00
9	2	Yoke Assembly	05700-000-75-77
10	2	Nut, 3/8"-16 S/S Hex Locking	05310-256-04-00
11	2	Rod, Spring Connecting	05700-002-00-91
12	4	Plate, Spring Multiplier	05700-002-00-88
13	4	Spring, Cantilever Door	05340-111-35-22

**CANTILEVER ARM/DOOR ASSEMBLIES**

<b>ITEM</b>	<b>QTY</b>	<b>DESCRIPTION</b>	<b>PART NUMBER</b>
14	4	Bolt, Cantilever Hanger Eye 3/8"-16	05306-956-05-00
15	4	Washer, Impeller	05311-176-02-00
16	8	Nut, 3/8"-16 S/S Hex	05310-276-01-00
	2	Door, Upper, Left & Right Assemblies (not shown)	05700-002-01-30
17	2	Door, Upper, Left & Right Weldment	05700-002-29-59
18	4	Glide, Upper Door	05700-002-00-83
	1	Door, Lower, Right Assembly (not shown)	05700-002-01-33
19	1	Door, Lower, Right	05700-004-14-18
20	2	Glide, Lower Door	05700-002-23-64
21	1	Door Stop Magnet Assembly	06401-003-08-68
	1	Door Stop Magnet Weldment (not shown)	05700-002-01-27
	1	Magnet (not shown)	05930-111-69-25
	2	End Cap (not shown)	05700-011-60-92
22	6	Bumper, Tempstar HH Door	05700-004-14-25
23	12	Screw, 1/4"-20 x 5/8"	05305-274-24-00
24	12	Locknut, 1/4"-20 S/S Hex with Nylon Insert	05310-374-01-00
25	2	Screw, 1/4"-20 x 1/2" Long Hex Head	05305-274-02-00
26	2	Spacer, PB Bolt	05700-000-29-40
27	2	Bracket, Door Connector	05700-004-14-24
28	1	Handle, Front Door Weldment	05700-004-14-30
	1	Door, Lower, Front Assembly (not shown)	05700-002-01-31
29	1	Door, Lower, Front	05700-004-14-22
30	2	Glide, Upper Door	05700-002-23-64
	1	Door, Upper Front Assembly (not shown)	05700-002-24-92
31	1	Door, Upper, Front Weldment	05700-002-29-57
32	2	Glide, Upper Door	05700-002-00-83
	1	Door, Lower, Left Assembly (not shown)	05700-002-01-32
	1	Door, Lower, Left Assembly (Door Lock) (not shown)	05700-004-24-21
33	1	Door, Lower, Left	05700-004-14-20
	1	Door, Lower, Left (Door Lock) (not shown)	05700-004-24-22
	1	Door Interlock Bracket (not shown)	05700-004-23-17
34	2	Glide, Lower Door	05700-002-23-64
35	6	Door Stop Weldment	05700-002-29-60
36	1	Door Stop	06401-003-08-69

# PARTS

## TUB ASSEMBLY

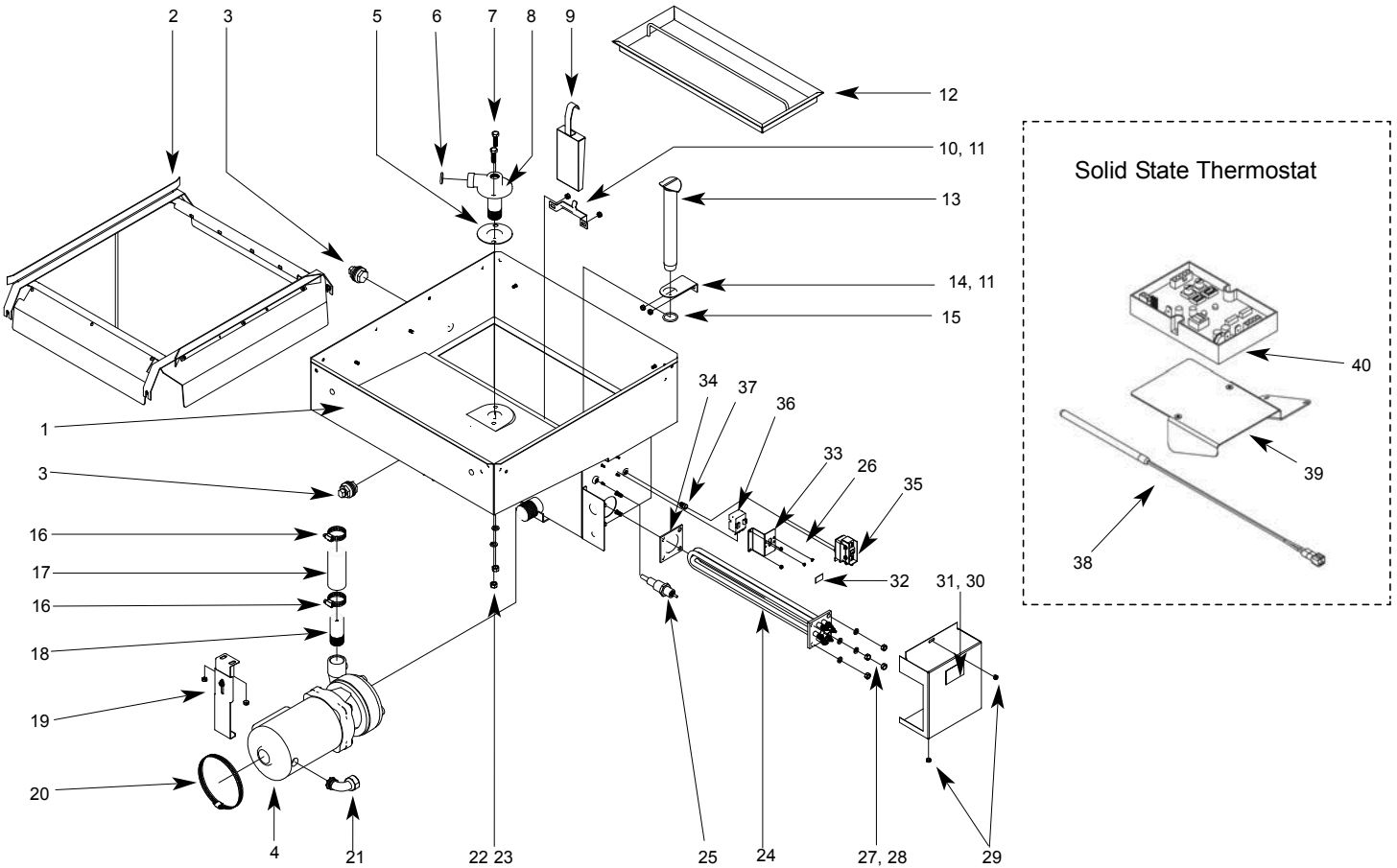

W-BRACKET, MOTOR MOUNT INNER  
05700-004-13-09

F-BRACKET, MOTOR MOUNT OUTER  
05700-004-13-08

BOLT, 1/4-20 X 1/2"  
05305-274-02-00

WASHER, 1/4" I.D. X 3/4" O.D.  
05311-011-76-30

LOCKNUT, 1/4-20  
05310-374-01-00

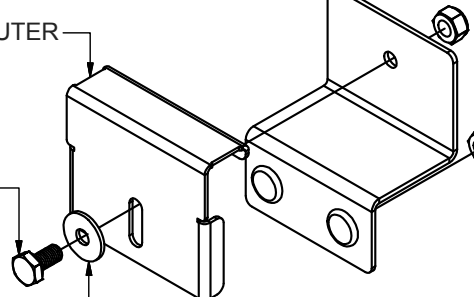



**PARTS****TUB ASSEMBLY (CONTINUED)**

<b>ITEM</b>	<b>QTY</b>	<b>DESCRIPTION</b>	<b>PART NUMBER</b>
1	1	Tub Weldment	05700-002-12-59
2	1	Rack Assembly	05700-002-01-00
3	2	Bulk Head Plug	04730-609-05-00
4	1	See Page Entitled "Wash Motors"	N/A
5	1	Gasket	05700-111-35-03
6	1	O-ring	05330-400-05-00
7	4	Bolt, Hex 3/8"-16 x 1 1/4" Long	05305-276-10-00
8	1	Lower Wash Manifold Weldment	05700-031-46-00
9	1	Suction Strain Weldment	05700-001-22-23
10	1	Suction Strain Bracket	05700-001-22-24
11	8	Locknut, 1/4"-20 with Nylon Insert	05310-374-02-00
12	1	Strainer Weldment	05700-021-50-07
13	1	Wash Overflow Weldment	05700-001-25-69
*	1	Support, Ball Stop Lift	05700-002-91-55
*	1	Ball Stop Lift	05700-002-91-54
*	1	Shim, Overflow Support	05700-002-96-48
14	1	Overflow Support Bracket	05700-001-27-55
15	1	O-Ring	05330-400-05-00
16	2	Clamp, Hose 1 5/16" to 2 1/4"	04730-719-01-37
17	1	Discharge Hose	05700-011-88-24
18	1	Nipple	05700-021-34-84
19	1	Pump Support Bracket Assembly	05700-002-00-46
20	1	Clamp, Hose 5 5/8" to 6"	04730-011-34-90
21	1	Connector, 1/2" 90B	05975-111-01-00
22	4	Nut, 3/8"-16 S/S Hex	05310-276-01-00
23	4	Lockwasher 3/8"	05311-276-01-00
24	1	See Page Entitled "Wash Heaters/Rinse Heaters" See page 27 to order phase conversion kits for the heater.	N/A
25	1	Probe, High Water	06680-200-02-68
26	5	Locknut, 6-32 with Nylon Insert	05310-373-03-00
27	4	Lockwasher, 5/16", S/S, Split	05311-275-01-00
28	4	Nut, Hex, 5/16"-18, S/S	05310-275-01-00
29	4	Locknut, 10-24 with Nylon Insert	05310-373-01-00

# PARTS

## TUB ASSEMBLY (CONTINUED)

ITEM	QTY	DESCRIPTION	PART NUMBER
30	1	Cover, Wash Heater	05700-031-47-57
31	1	Decal, Warning-Disconnect Power	09905-100-75-93
32	1	Decal, High Limit	09905-011-84-32
33	1	Thermostat Bracket	05700-011-81-64
34	1	Wash Heater Gasket	05330-011-47-79
35	1	Thermostat, Regulating	05930-510-02-79
	1	Kit, Wash Thermostat Replacement (Includes: thermostat, brass fitting, 2 jumper wires & instructions)	06401-003-18-22
36	1	Thermostat, High Limit	05930-011-49-43
37	1	Fitting, 1/4" Imperial Brass	05310-924-02-05
38	1	Probe, Thermister 4" LG	06685-004-17-26
39	1	Thermostat Mounting Bracket	05700-004-22-17
40	1	Thermostat, Elan Electric Dual	05585-004-17-27

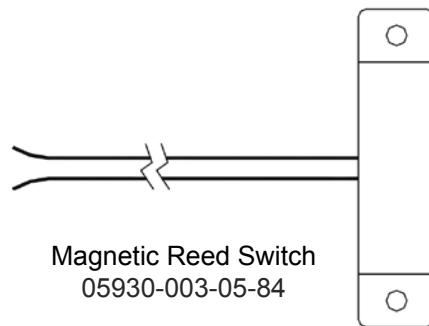

### Associated Hardware:

Lockwasher, #8 Internal Tooth	05311-272-03-00
Locknut, 1/4"-20 S/S Hex with Nylon Insert	05310-374-01-00
Screw, 8-32 x 3/4" Round Head	05305-172-06-00

# PARTS

## STEAM TUB ASSEMBLY

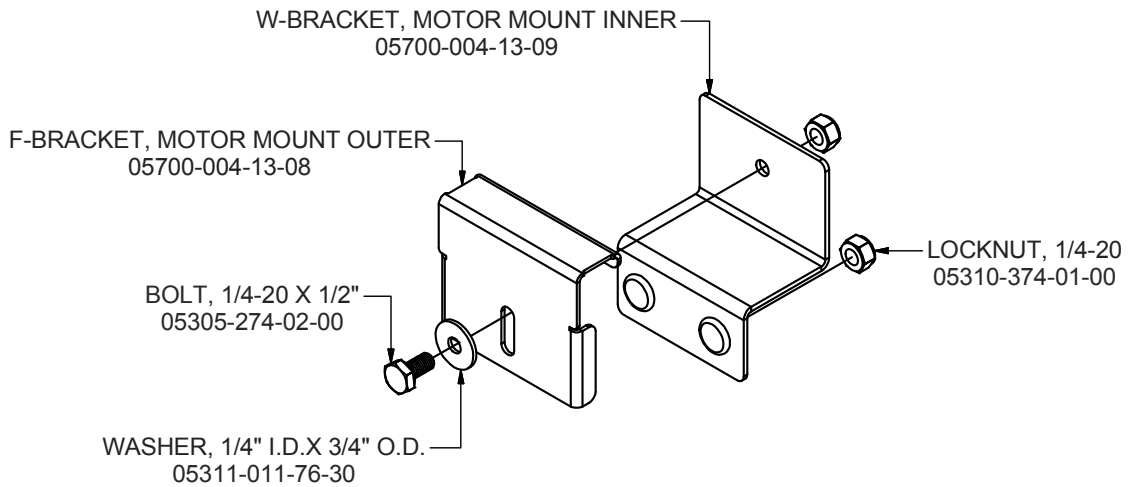
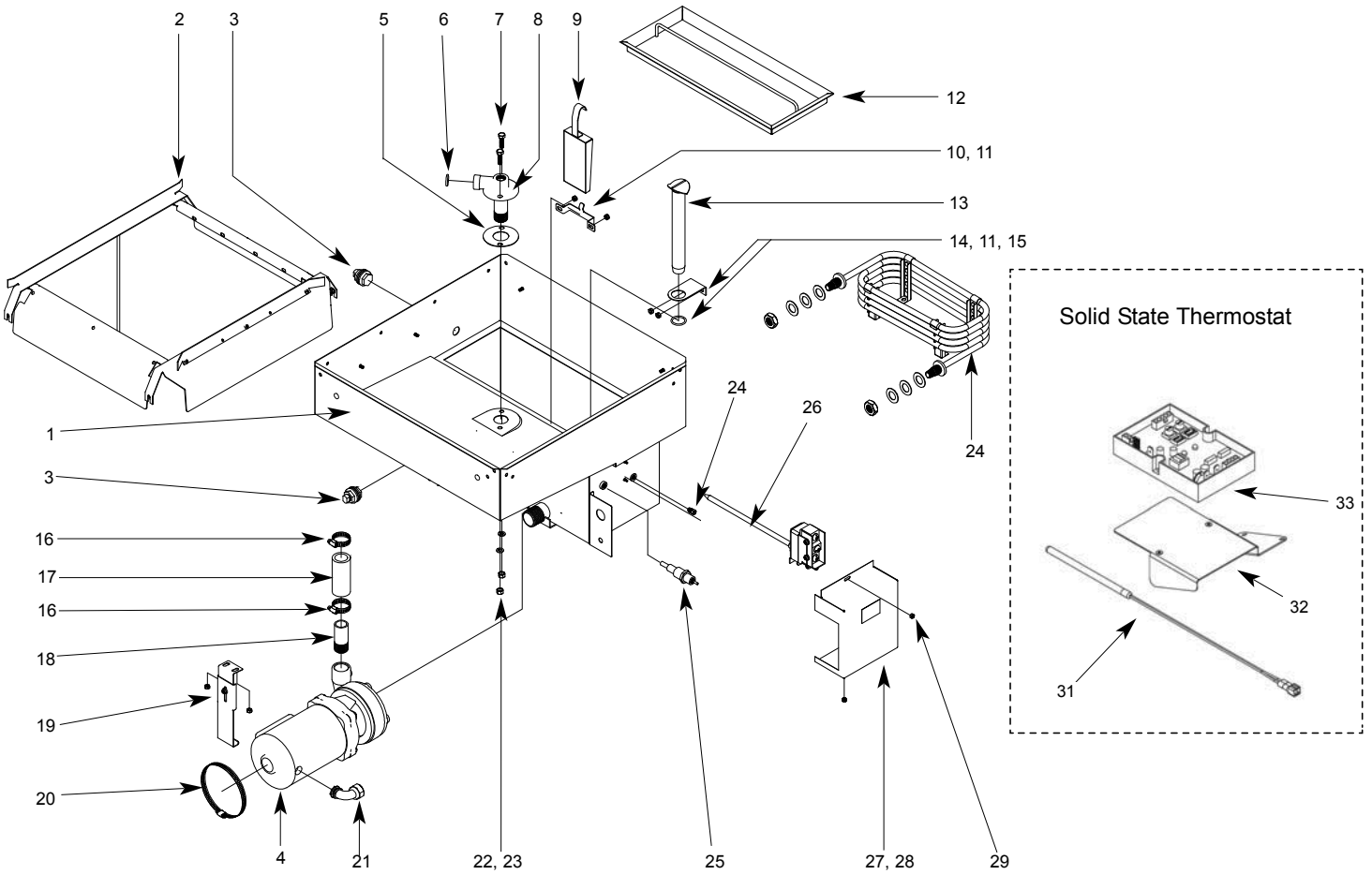

ITEM	QTY	DESCRIPTION	PART NUMBER
1	1	Tub Weldment	05700-002-09-26
2	1	Rack Assembly	05700-002-01-00
3	2	Bulk Head Plug	04730-609-05-00

**PARTS****STEAM TUB ASSEMBLY (CONTINUED)**

4	1	See page entitled "Wash Motors"	N/A
5	1	Gasket	05700-111-35-03
6	1	O-ring	05330-400-05-00
7	4	Bolt, Hex 3/8"-16 x 1 1/4" Long	05305-276-10-00
8	1	Lower Wash Manifold Weldment	05700-031-46-00
9	1	Suction Strain Weldment	05700-001-22-23
10	1	Suction Strain Bracket	05700-001-22-24
11	8	Locknut, 1/4"-20 with Nylon Insert	05310-374-02-00
12	1	Strainer Weldment	05700-021-50-07
13	1	Wash Overflow Weldment	05700-001-25-69
*	1	Support, Ball Stop Lift	05700-002-91-55
*	1	Ball Stop Lift	05700-002-91-54
*	1	Shim, Overflow Support	05700-002-96-48
14	1	Overflow Support Bracket	05700-001-27-55
15	1	O-Ring	05330-400-05-00
16	2	Clamp, Hose 1 5/16" to 2 1/4"	04730-719-01-37
17	1	Discharge Hose	05700-011-88-24
18	1	Nipple	05700-021-34-84
19	1	Pump Support Bracket Assembly	05700-002-00-46
20	1	Clamp, Hose 5 5/8" to 6"	04730-011-34-90
21	1	Connector, 1/2" 90 Deg.	05975-111-01-00
22	4	Nut, 3/8"-16 S/S Hex	05310-276-01-00
23	4	Lockwasher 3/8"	05311-276-01-00
24	1	Fitting, 1/4" Imperial Brass	05310-924-02-05
25	1	Probe, High Water	06680-200-02-68
26	1	Thermostat, Regulating	05930-510-02-79
	1	Kit, Wash Thermostat Replacement (Includes: thermostat, brass fitting, 2 jumper wires & instructions)	06401-003-18-67
27	1	Cover, Wash Heater	05700-031-47-57
28	1	Decal, Warning-Disconnect Power	09905-100-75-93
29	2	Locknut, 10-24 with Nylon Insert	05310-373-01-00
30	3	Locknut, 6-32 with Nylon Insert	05310-373-03-00
31	1	Probe, Thermister 4" LG	06685-004-17-26
32	1	Thermostat Mounting Bracket	05700-004-22-17
33	1	Thermostat, Elan	Electric Dual

---

**PARTS**  
*FRAME ASSEMBLY*

Cover, Front Panel  
05700-002-01-42

Frame Weldment  
05700-002-03-49

Frame Weldment, 415V  
05700-002-62-41

Frame Weldment  
05700-004-22-56

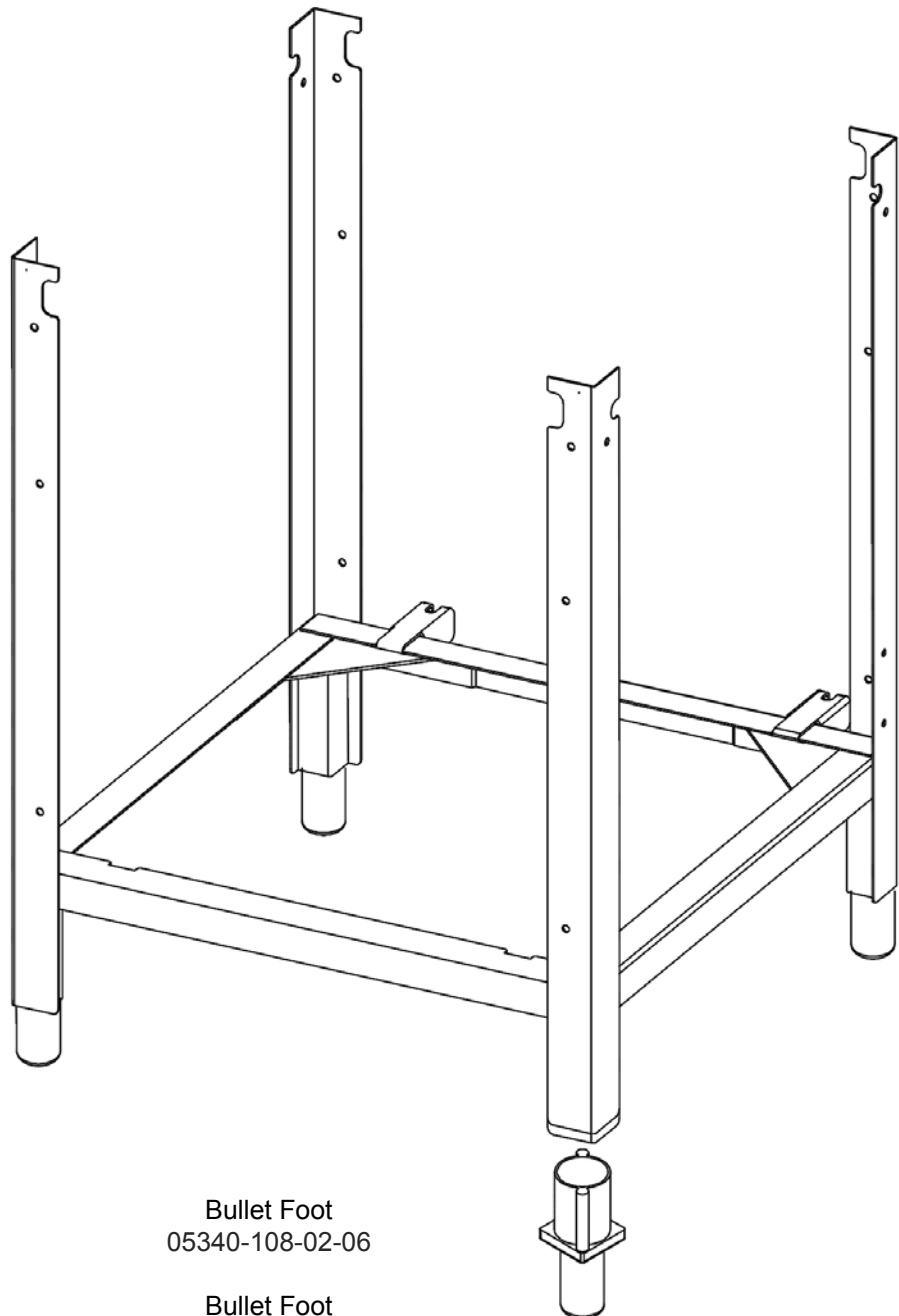

Bullet Foot  
05340-108-02-06

Bullet Foot  
05340-002-14-55

Flange Feet  
05340-002-01-15

# PARTS

## RINSE TANK ASSEMBLY

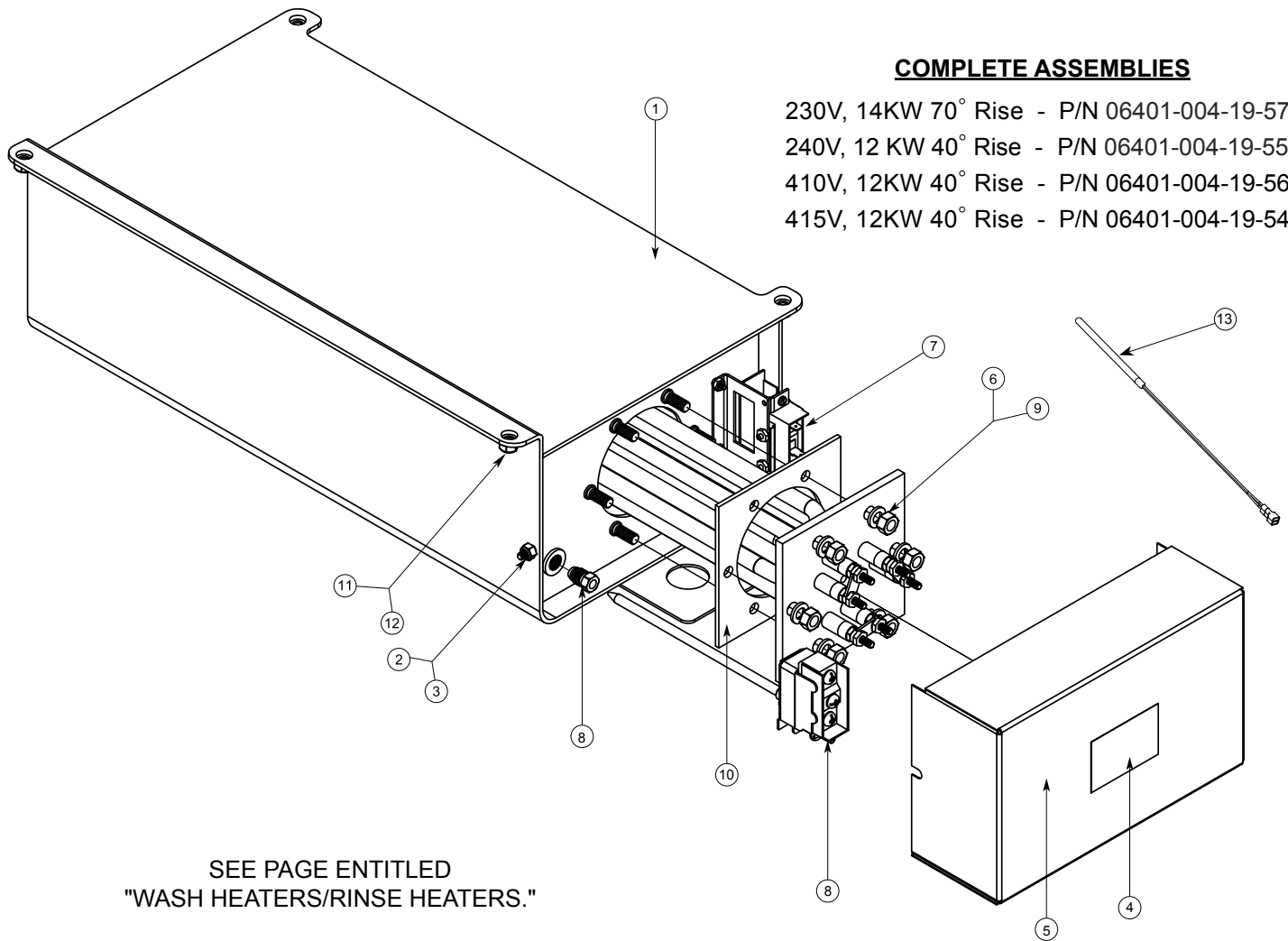

SEE PAGE ENTITLED  
"WASH HEATERS/RINSE HEATERS."

ITEM	QTY	DESCRIPTION	PART NUMBER
1	1	Booster Tank Weldment	05700-002-10-19
2	2	Locknut, 10-24 with Nylon Insert	05310-373-01-00
3	2	Washer, #10 S/S Flat	05311-173-01-00
4	1	Decal, Warning-Disconnect Power	09905-100-75-93
5	1	Booster Tank Cover Weldment	05700-002-16-51
6	6	Nut, Hex, 5/16"-18	05310-275-01-00
7	1	Thermostat, High Limit	05930-011-49-43
8	1	Thermostat, Regulating with Imperial Brass Fitting	06401-011-66-55
9	6	Lockwasher, 5/16" Split	05311-275-01-00
10	1	Gasket, Rinse Heater	05330-200-02-70
11	4	Locknut, 1/4"-20 with Nylon Insert	05310-374-01-00
12	4	Washer, 1/4" S/S Flat	05311-174-01-00
13	1	Probe, Thermistor 4" LG	06685-004-17-26

Complete Steam Coil Assembly  
05700-002-08-62

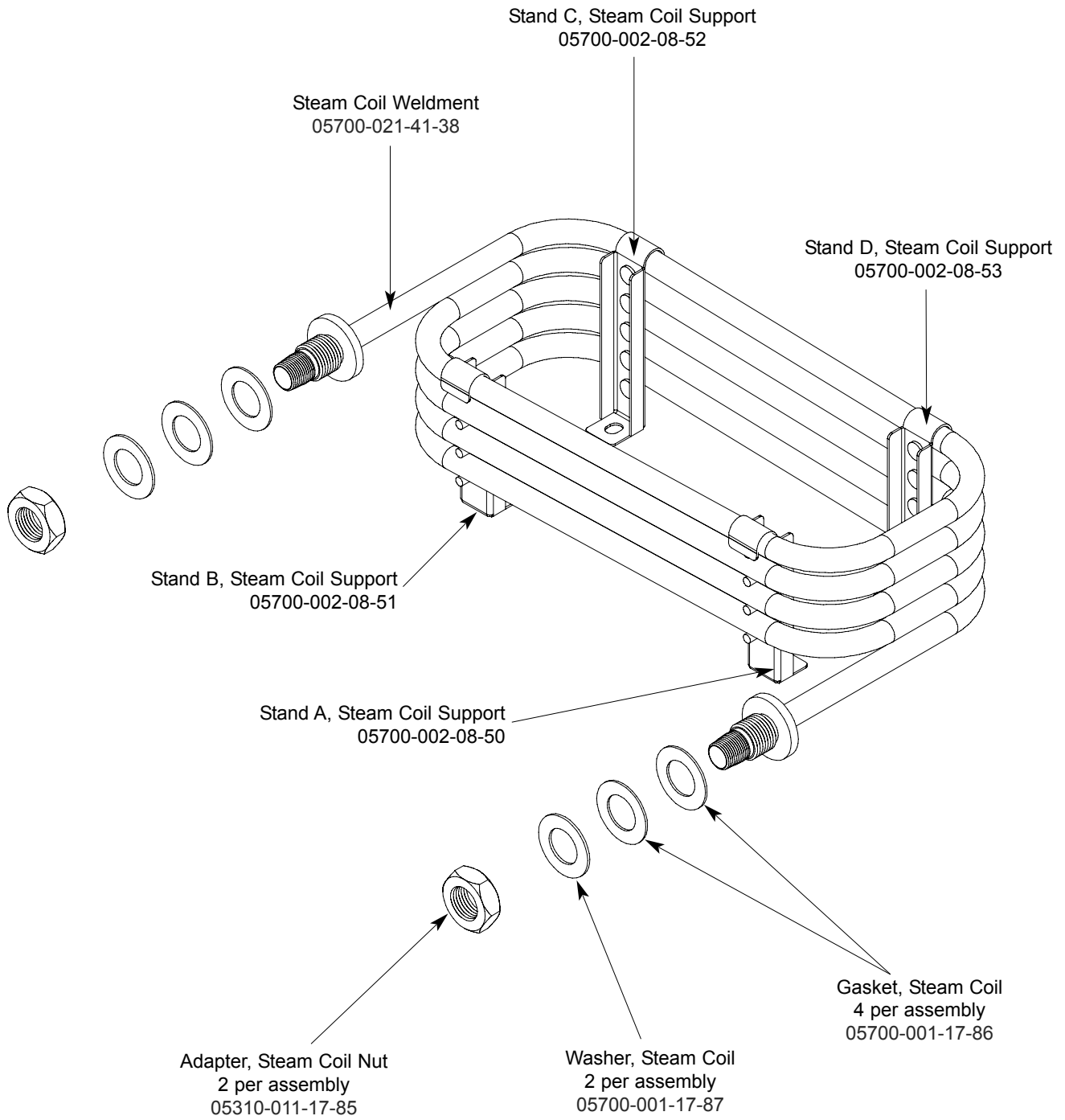

# PARTS

## INCOMING STEAM PLUMBING ASSEMBLIES

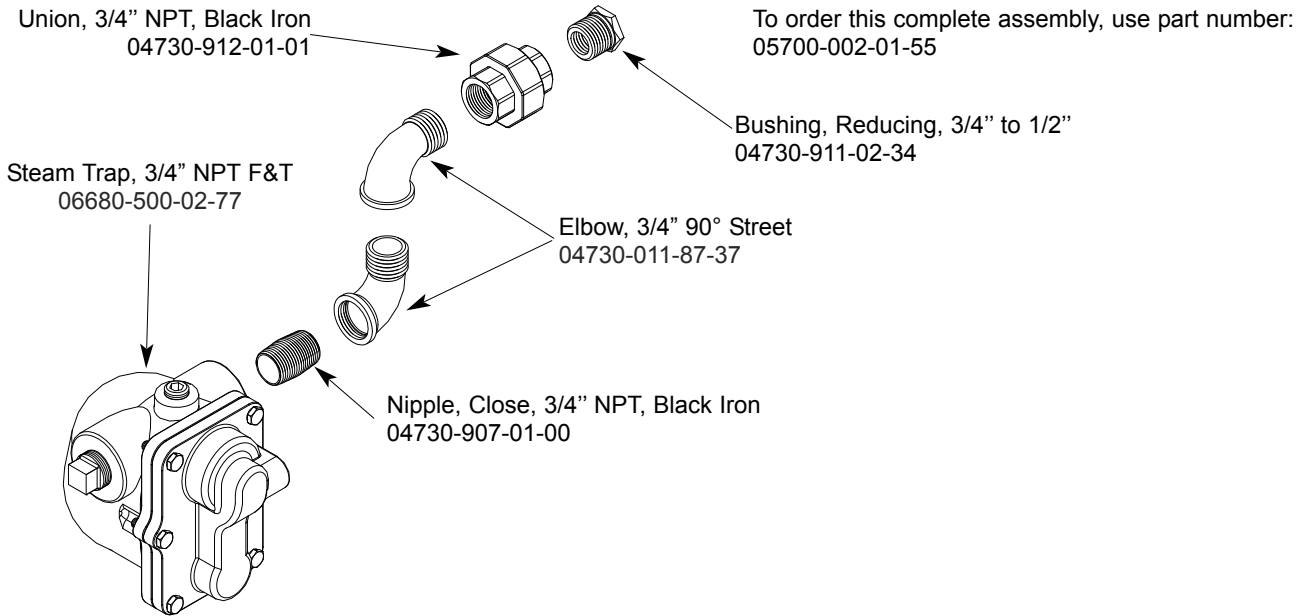

To order this complete assembly, use part number:  
05700-002-01-60

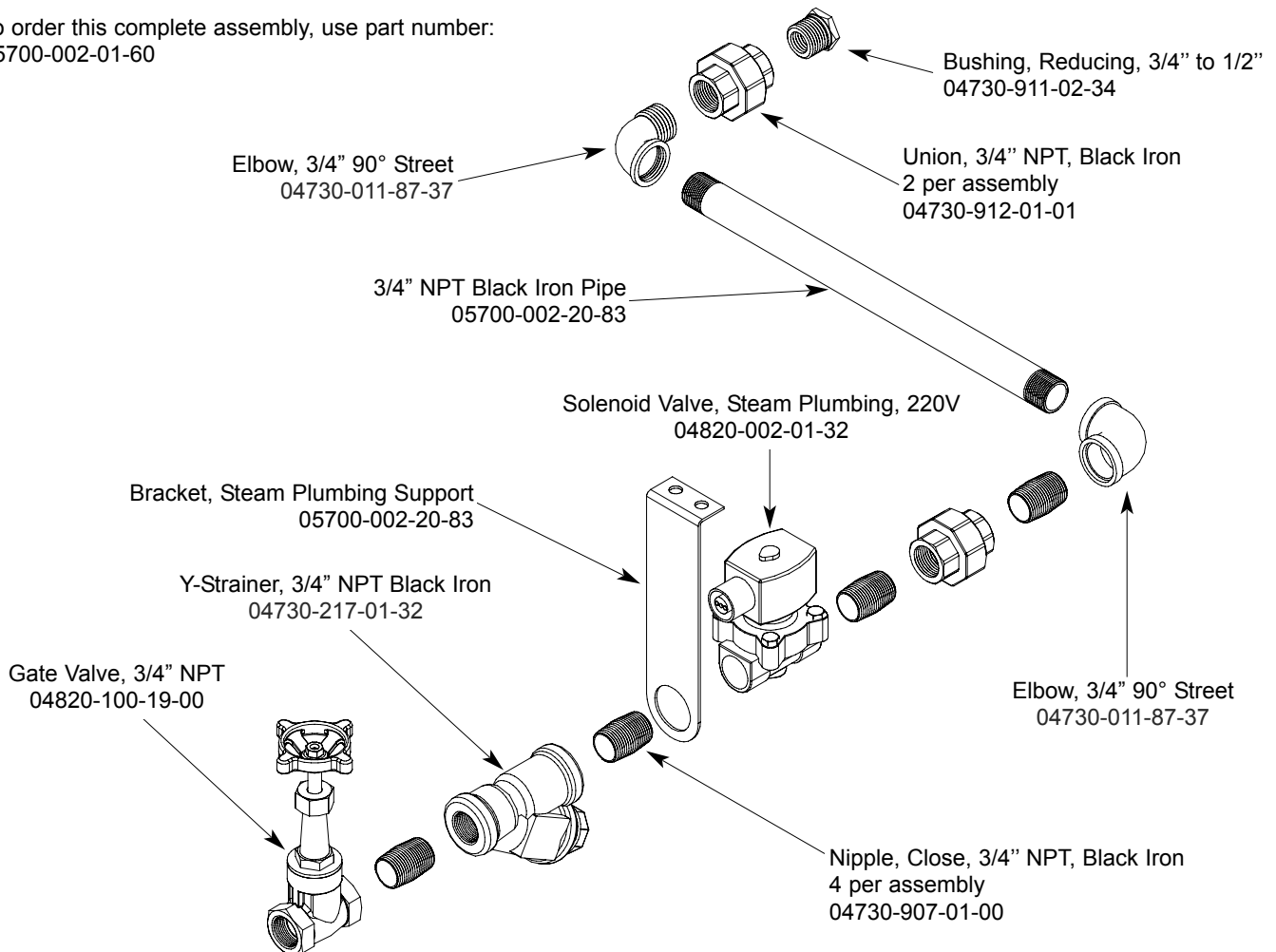



**MOTORS — WASH HEATERS — RINSE HEATERS**

The models covered in this manual come supplied with various wash motor assemblies (a wash motor assembly includes the wash motor and the pump end), depending on the characteristics of the machine. To ensure that the correct wash motor assembly is ordered for the model being serviced, refer to the following table:

MODEL	VOLTS	Hz	PHASE	WASH MOTOR ASSEMBLY
Tempstar HH	415	50	3	06105-002-45-07
Tempstar HH, HH NB, HH S, HH LT	208	60	1	06105-002-01-29
Tempstar HH, HH NB, HH S, HH LT	230	60	1	06105-002-01-29
Tempstar HH, HH NB, HH S, HH LT	208	60	3	06105-002-01-29
Tempstar HH, HH NB, HH S, HH LT	230	60	3	06105-002-01-29
Tempstar HH, HH NB, HH S, HH LT	460	60	3	06105-002-09-30

**NOTE:** When servicing a wash motor please refer to the wiring schematic found on the motor to ensure that it is wired correctly. Different manufacturers use different wire color codes and your new motor may not connect using the same wires. Always refer to the diagrams on the motor you are installing. If the schematics have been removed from the motor you are installing, contact Jackson technical support immediately.

The Tempstar models covered in this manual come supplied with various heaters, depending on the characteristics of the machine. To ensure that the correct heater is ordered for the model being serviced, refer to the following table:

MODEL	V	Hz	PH	WASH HEATER ASSEMBLY	40°F RISE RINSE HEATER (12KW)	70°F RISE RINSE HEATER (14KW)
Tempstar HH	415	50	3	04540-002-43-09	04540-002-43-10	N/A
Tempstar HH	208	60	1	04540-121-47-39	04540-121-47-40	04540-121-63-38
Tempstar HH	230	60	1	04540-121-47-39	04540-121-47-40	04540-121-63-38
Tempstar HH	208	60	3	04540-121-47-39	04540-121-47-40	04540-121-63-38
Tempstar HH	230	60	3	04540-121-47-39	04540-121-47-40	04540-121-63-38
Tempstar HH	460	60	3	04540-121-65-99	04540-100-01-15	04540-121-63-39
Tempstar HH NB, HH LT	208	60	1	04540-121-47-39		
Tempstar HH NB, HH LT	230	60	1	04540-121-47-39		
Tempstar HH NB, HH LT	208	60	3	04540-121-47-39		
Tempstar HH NB, HH LT	230	60	3	04540-121-47-39		
Tempstar HH NB, HH LT	460	60	3	04540-121-65-99		
Tempstar HH S	208	60	1	04540-121-47-39		
Tempstar HH S	230	60	1	04540-121-47-39		
Tempstar HH S	208	60	3	04540-121-47-39		
Tempstar HH S	230	60	3	04540-121-47-39		
Tempstar HH S	460	60	3	04540-121-65-99		

# PARTS

## INCOMING & OUTLET PLUMBING ASSEMBLIES

INCOMING PLUMBING

OUTLET PLUMBING

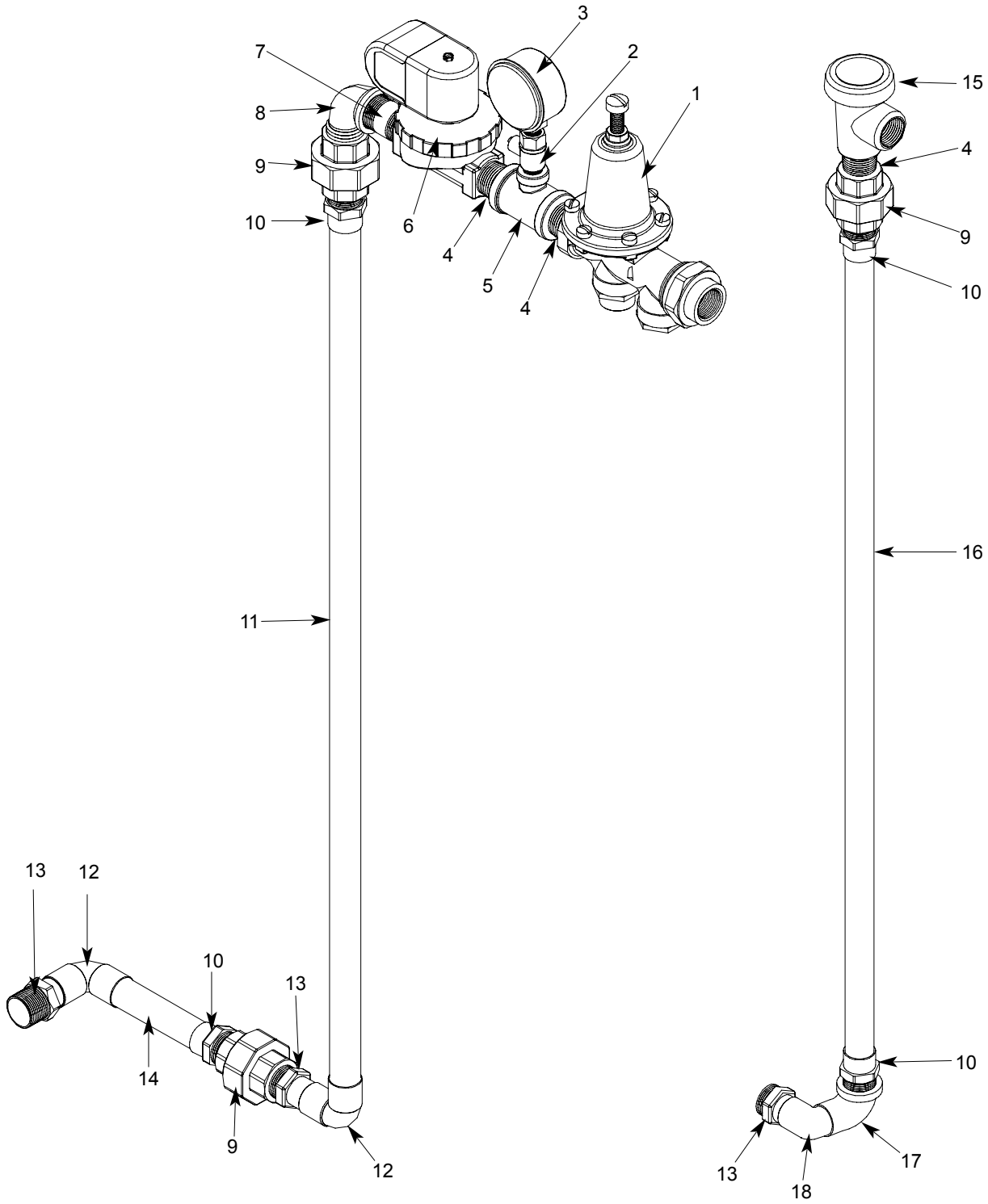

*INCOMING & OUTLET PLUMBING ASSEMBLIES (CONTINUED)*

ITEM	QTY	DESCRIPTION	PART NUMBER
1	1	Water Pressure Regulator, 3/4" NPT	06685-011-58-22
2	1	Valve, Ball, 1/4" NPT	04810-011-72-67
3	1	Gauge, Pressure, 0-100 PSI	06685-111-88-34
4	2	Nipple, Close 3/4" NPT	04730-207-34-00
5	1	Tee, Brass, 3/4" NPT x 3/4" NPT x 1/4" NPT	04730-211-04-00
6	1	Valve, Solenoid, 3/4" NPT	04810-100-03-18
7	1	Nipple, Brass, 3/4" NPT x 2" Long	04730-207-46-00
8	1	Elbow, 3/4" NPT, Brass, Street	04730-206-04-34
9	3	Union, 3/4" NPT, Brass with O-Ring	05700-002-63-79
10	4	Adapter, 3/4" Male	04730-401-11-01
11	1	Tube, Copper, 3/4" x 48" Long	05700-011-87-89
12	2	Elbow, 3/4" 90°, #707 Copper	04730-406-16-01
13	3	Adapter, 3/4", 604-2	04730-401-10-01
14	1	Tube, Copper, 3/4" x 3 3/4" Long	05700-011-58-28
15	1	Vacuum Breaker, 3/4" NPT	04820-002-53-77
16	1	Tube, Copper, 3/4" x 44 3/8" Long	05700-002-25-05
17	1	Elbow, 3/4" 90° Copper to FSPS Brass	04730-406-41-01
18	1	Elbow, 3/4" 90° Copper to Copper Street	04730-406-40-01
	2	Double Pipe Clamp (not shown)	05700-002-23-89
	1	Bracket, Incoming Plumbing Support	05700-021-34-02

When servicing plumbing components, take care not to damage the threads of each individual item. Damaged threads can cause leaks and loss of pressure, which could adversely affect the performance of the dishwasher. It is strongly recommended that teflon thread tape be applied conservatively to threads when joining components together. It is not advised to use thread sealing compounds, or "pipe dope," as they can be ejected from the threads during the tightening process and become lodged in key components.

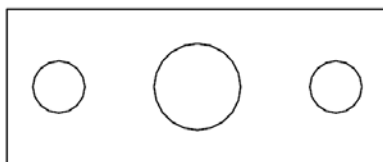

**Rinse Injector Gasket**  
 2 per machine  
 05330-111-42-81

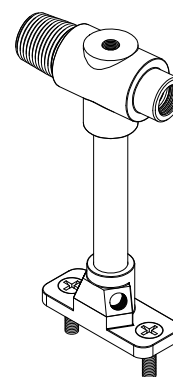

**Rinse Injector Weldment**  
 1 per machine  
 05700-021-47-65  
**Plug, 1/8" NPT, Brass**  
 3 per Rinse Injector  
 04730-209-07-37

# PARTS

## INCOMING PLUMBING (TEMPSTAR HH NB)

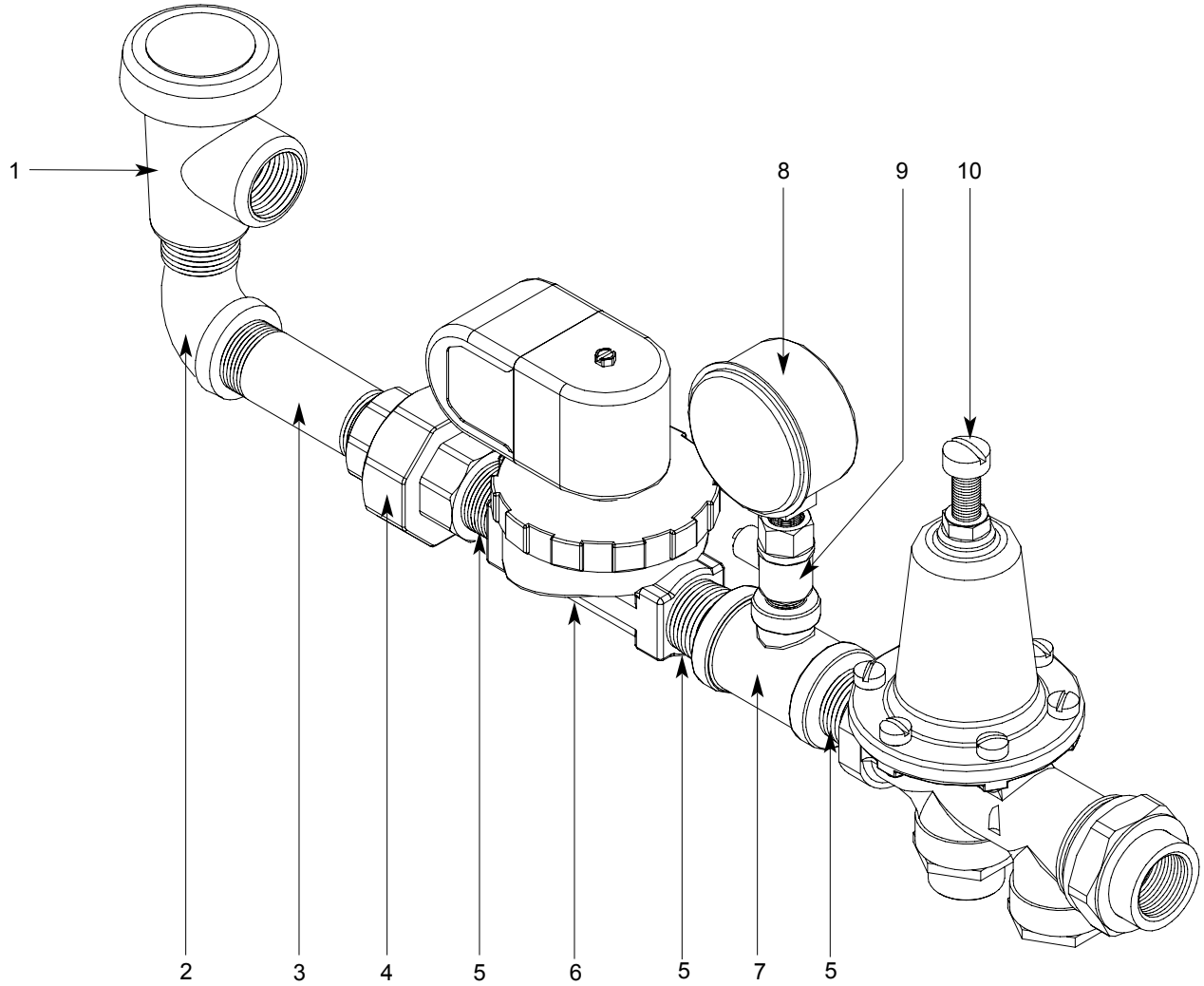

ITEM	QTY	DESCRIPTION	PART NUMBER
1	1	Vacuum Breaker, 3/4" NPT	04820-002-53-77
2	1	Elbow, Brass, Street, 3/4" NPT	04730-206-04-34
3	1	Nipple, Brass, 3/4" NPT x 3" Long	04730-011-38-29
4	1	Union, 3/4" NPT, Brass with O-Ring	05700-002-63-79
5	3	Nipple, Close, Brass, 3/4" NPT	04730-207-34-00
6	1	Valve, Solenoid, 3/4" NPT	04810-100-03-18
7	1	Tee, Brass, 3/4" NPT x 3/4" NPT x 1/4" NPT	04730-211-04-00
8	1	Pressure Gauge, 0-100 PSI	06685-111-59-66
9	1	Valve, Ball, Bronze, 1/4" NPT	04810-011-72-67
10	1	Water Pressure Regulator	06685-011-58-22

# PARTS

## INCOMING PLUMBING (TEMPSTAR HH LT)

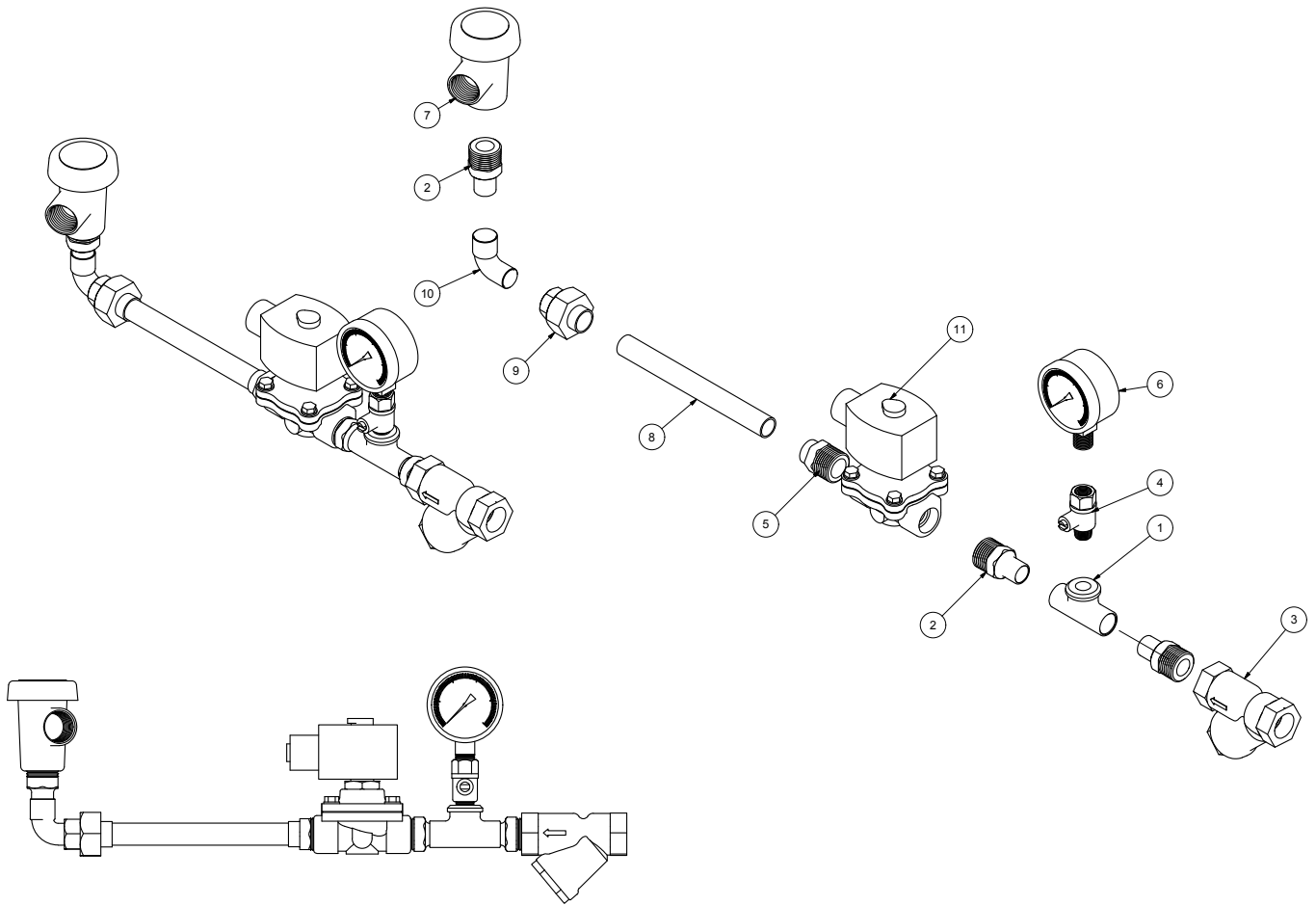

ITEM	QTY	DESCRIPTION	PART NUMBER
1	1	Fittin, Tee, 1/2C X 1/2C x 1/4 Female	04730-411-25-01
2	3	Adapter, 1/2 MNPT X CU Male	04730-011-59-53
3	1	Strainer, Y 1/2	04730-217-01-10
4	1	Vale, Ball Test Cock 1/4" Bronze	04810-011-72-67
5	1	Adapter, Male	04730-401-03-01
6	1	Gauge, 0-100# Pressure	06685-111-88-34
7		Vacuum Breaker 1/2"	04820-003-06-13
8	1	F-Copper Pipe, 5.75 Long	05700-002-91-03
9	1	Union, 1/2"	04730-412-05-01
10	1	Elbow, 1/2"	04730-406-31-01
11	1	Valve, 1/2" 208/60	04810-003-71-56

# PARTS

## INCOMING PLUMBING (TEMPSTAR HH VENTLESS)

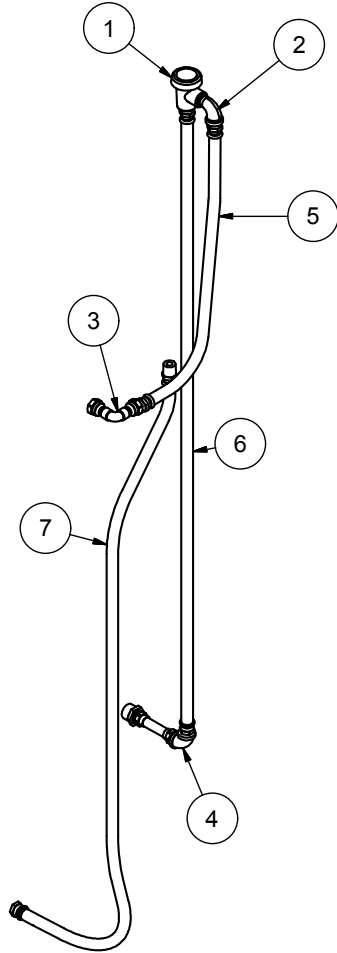

**RINSE INJECTOR**  
09515-004-22-73



ITEM	QTY	DESCRIPTION	PART NUMBER
1	1	Vac Breaker 1/2 Brass	04820-003-06-13
2	1	Elbow, 90 Degree 1/2 Street Brass	04730-206-08-00
3	1	W-Plumbing, Rinse Injector	05700-004-19-83
4	1	A-Plumbing, Outlet w/ Heat Exc.	05700-004-19-12
5	1	Hose, 1/2" ID X 24" LG Red	05700-004-19-89
6	1	Hose, 1/2" ID X 67" LG Red	05700-004-19-99
7	1	Hose, 1/2" ID X 69" LG Blue	05700-004-20-00

*INCOMING PLUMBING (TEMPSTAR HH VENTLESS)*

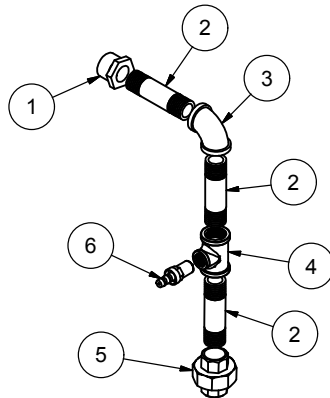

ITEM	QTY	DESCRIPTION	PART NUMBER
1	1	Bushing, Hex 3/4"M to 1/2" Brass	04730-002-56-27
2	3	Nipple, Brass 1/2" X 3" NPT	04730-004-20-10
3	1	Elbow, 1/2 NPT 90 Brass	04730-011-42-96
4	1	Tee, 1/2 FNPT X 1/2 FNPT 1/4 FNPT	04730-002-22-56
5	1	Union, 1/2" X 1/2" Brass	04730-003-62-44
6	1	Fitting, 1/4 Barb 1/4 MNPT Swivel	04730-011-95-41

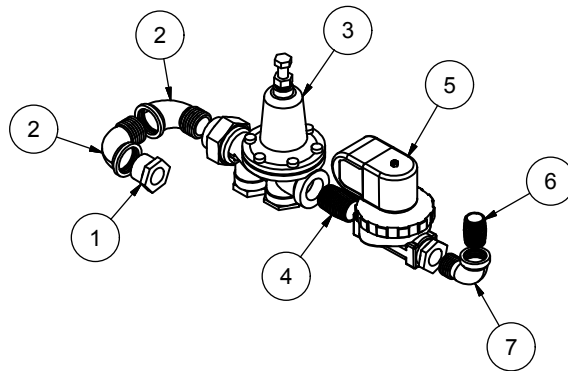

ITEM	QTY	DESCRIPTION	PART NUMBER
1	1	Bushing, Hex 3/4"M to 1/2" Brass	04730-002-56-27
2	3	Elbow, 3/4 Street Brass 90 Degree	04730-206-04-34
3	1	Regulator, Pressure 3/4	06685-011-58-22
4	1	Nipple, 3/4 NPT X 1-3/8 Closed Brass	04730-207-34-00
5	1	Valve, 3/4" - 220V Solenoid	04810-100-03-18
6	1	Nipple, 1/2 Closed Brass	04730-207-15-00
7		Elbow, 90 Degree 1/2 Street Brass	04730-206-08-00

# PARTS

## DRAIN QUENCH ASSEMBLY

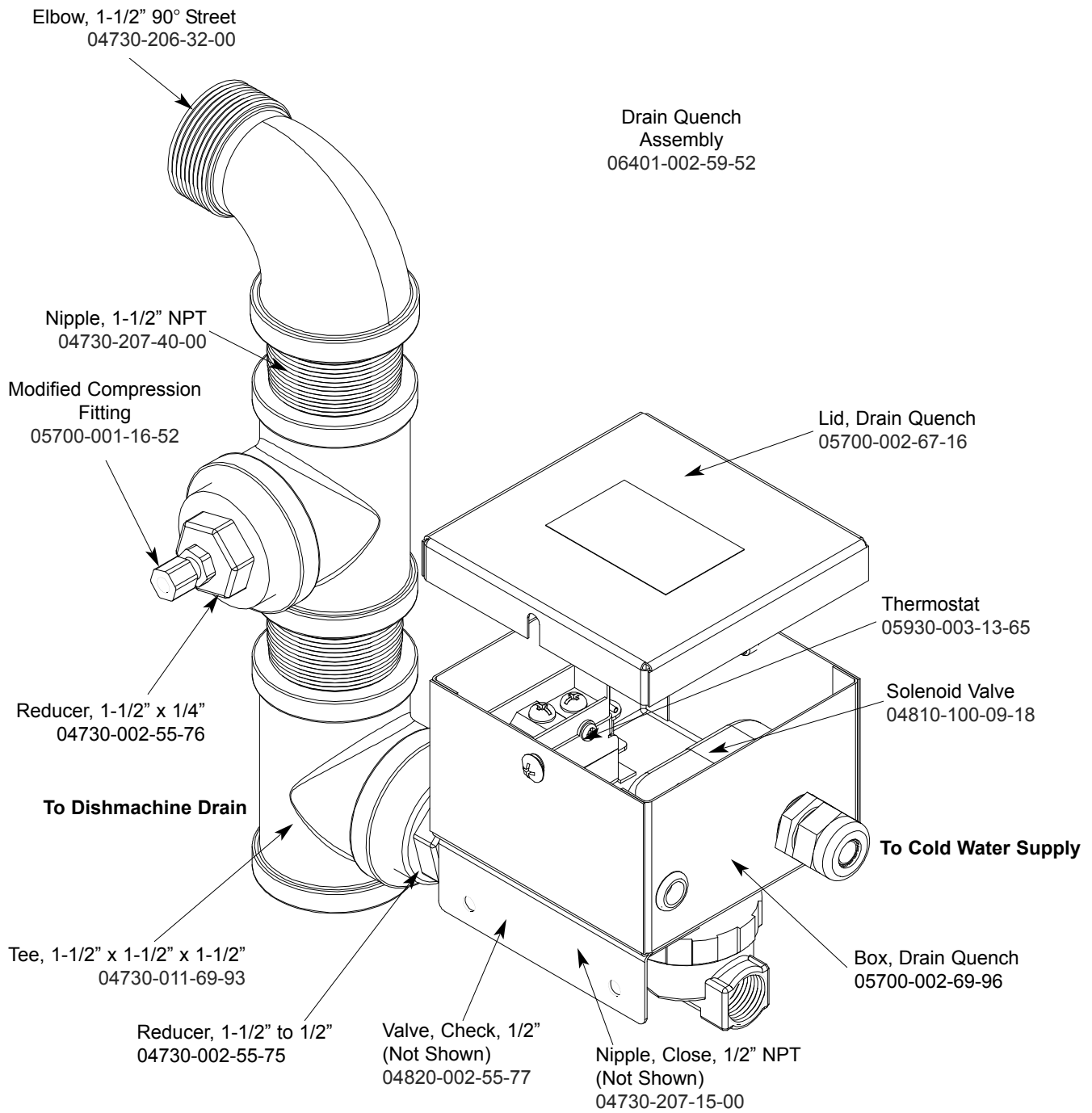

From the existing drain, attach two additional Tees using the 1-1/2" NPT Close Nipples. Tighten the Reducers into the Tees as shown above. Attach the Modified Compression Fitting into the 1-1/2" to 1/4" Reducer. Position the bulb of the thermostat so that it rests approximately 1/4" from the bottom of the Tee. Tighten the Modified Compression Fitting as required. Attach to the incoming cold water line. Use thread tape as required to prevent any leaks.



**3/4" SOLENOID VALVE & 3/4" VACUUM BREAKER REPAIR PARTS KITS**

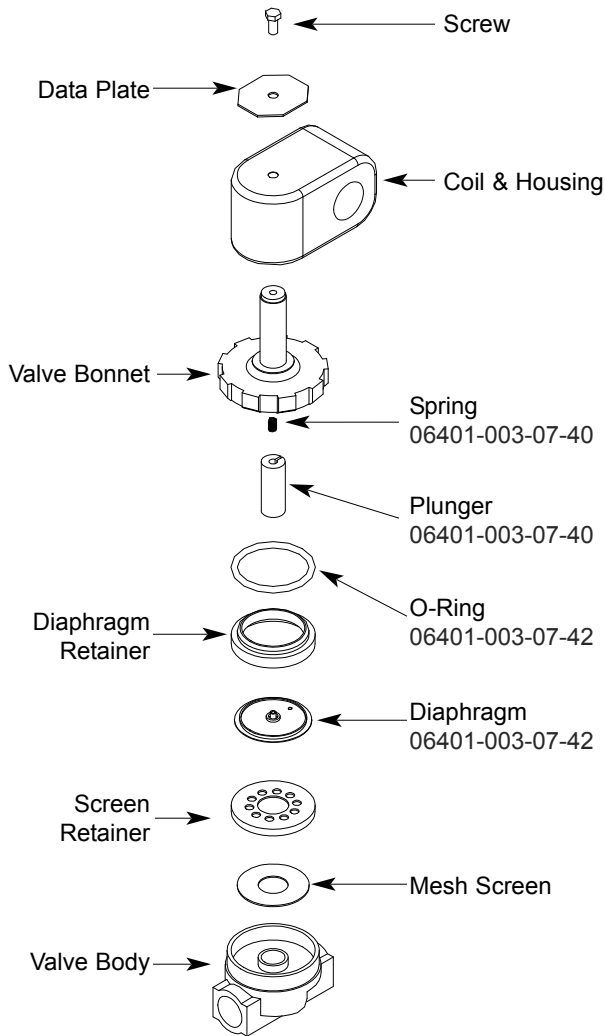

**Complete 240 Volt Solenoid Valve Assembly**  
04810-100-03-18

**Coil & Housing only**  
06401-003-07-44

**1/2" Complete 240 Volt Solenoid Valve Assembly  
(LT ONLY)**  
04810-003-71-56

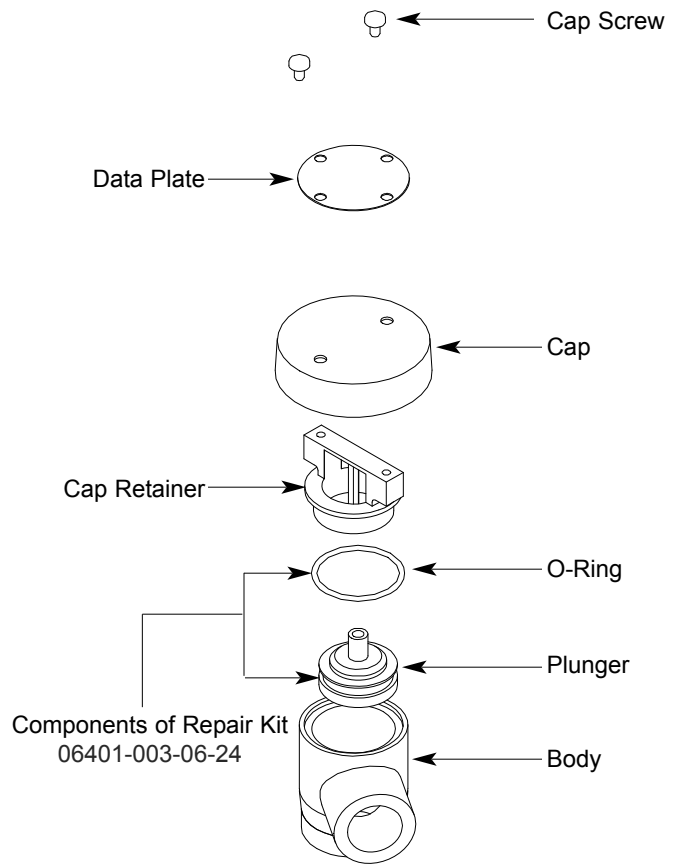

**Complete Vacuum Breaker Assembly**  
04820-002-53-77

# PARTS

## WASH & RINSE ARM/MANIFOLD ASSEMBLIES

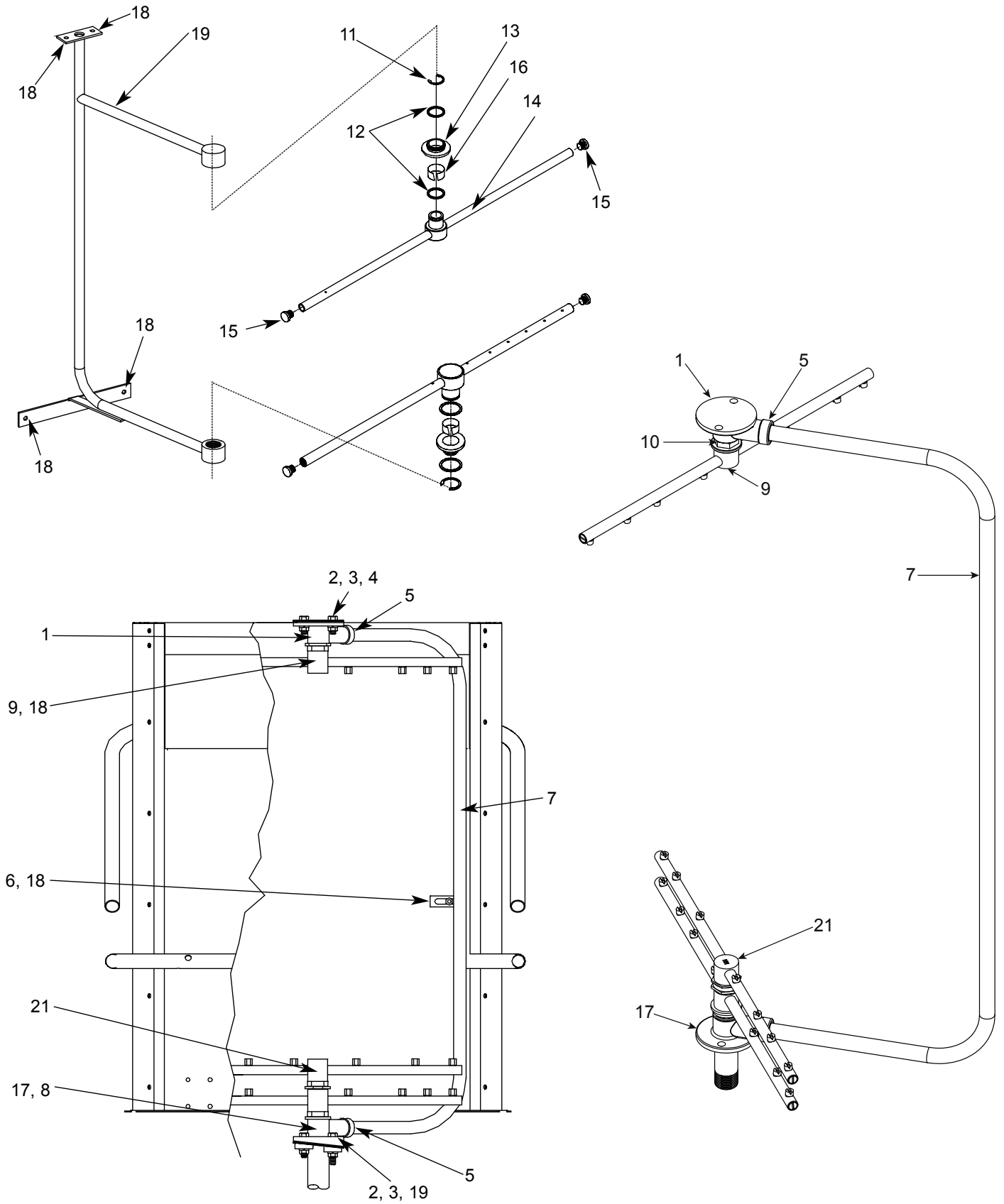

## WASH &amp; RINSE ARM/MANIFOLD ASSEMBLIES (CONTINUED)

ITEM	QTY	DESCRIPTION	PART NUMBER
1	1	Upper Manifold	05700-031-34-82
2	4	Nut, 3/8"-16 S/S Hex	05310-276-01-00
3	4	Lockwasher, 3/8"	05311-276-01-00
4	2	Bolt, Hex 3/8"-16 x 7/8" Long	05306-011-36-95
5	2	O-Ring	05330-111-35-15
6	1	Positioning Bracket, Manifold Tube	05700-011-34-63
7	1	Tube, Wash Manifold	05700-031-92-58
8	2	Gasket, Manifold	05700-111-35-03
9	1	Wash Arm Assembly	05700-004-13-13
10	1	Bearing Assembly	05700-021-35-97
	1	Wash Arm Assembly, 415V (not shown)	05700-021-63-81
	1	Wash Arm Weldment, 415V	05700-021-63-42
	1	Bearing Assembly, 415V	05700-021-63-80
	2	Rinse Arm Assembly	05700-002-58-09
11	2	Clip, Retaining, Rinse Head Bushing	05340-112-01-11
12	4	Washer	05330-011-42-10
13	2	Bushing, Rinse Head	05700-021-33-84
14	2	Rinse Arm	05700-031-49-58
15	4	Plug	04730-609-04-00
16	2	Bearing	03120-004-12-13
17	1	Lower Wash Manifold Weldment	05700-002-21-70
18	5	Locknut, 1/4"-20 S/S Hex with Nylon Insert	05310-374-01-00
19	1	Rinse Manifold Weldment	05700-002-01-19
20	2	Bolt, Hex 3/8"-16 x 1 1/4" Long	05305-276-10-00
21	1	Wash Arm, Double Assembly	05700-031-92-49
	1	Wash Arm, Double Assembly, 415V (not shown)	05700-002-46-86

# PARTS

## 460 VOLT MACHINE TRANSFORMER MOUNTING BOX

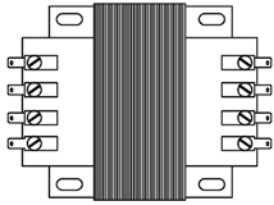

**460V Transformer**  
05950-111-65-93

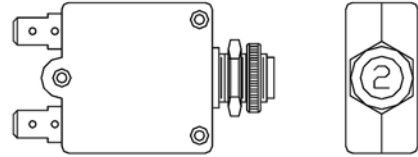
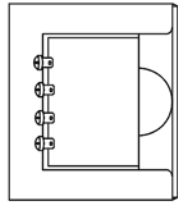

**2 Amp Circuit Breaker**  
05925-111-64-18

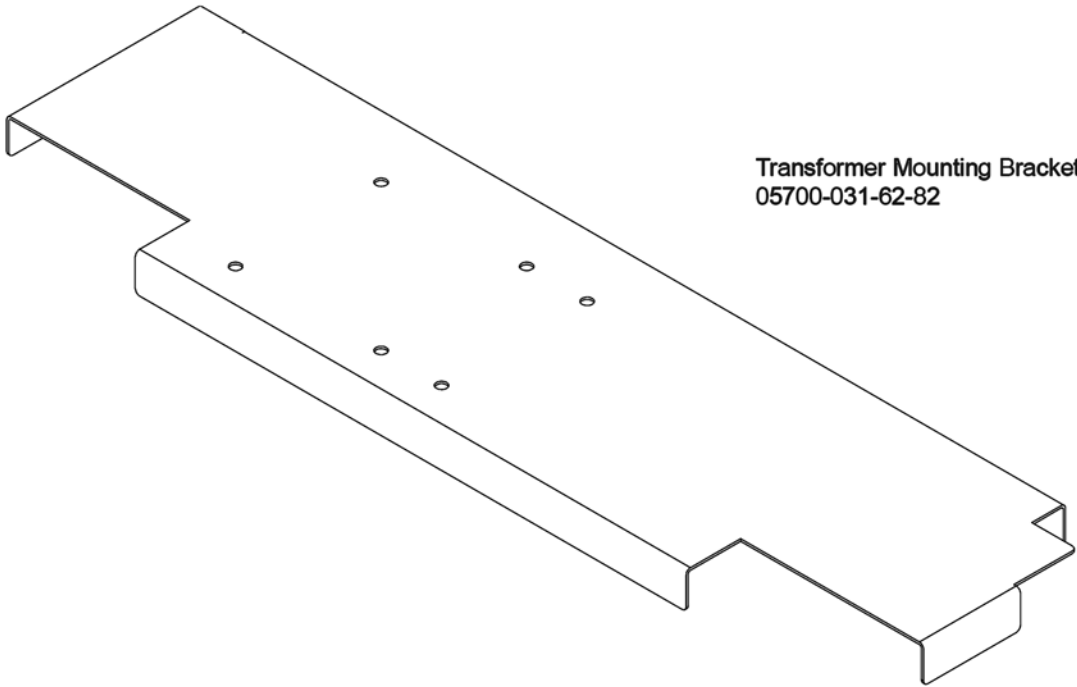

**Transformer Mounting Bracket**  
05700-031-62-82

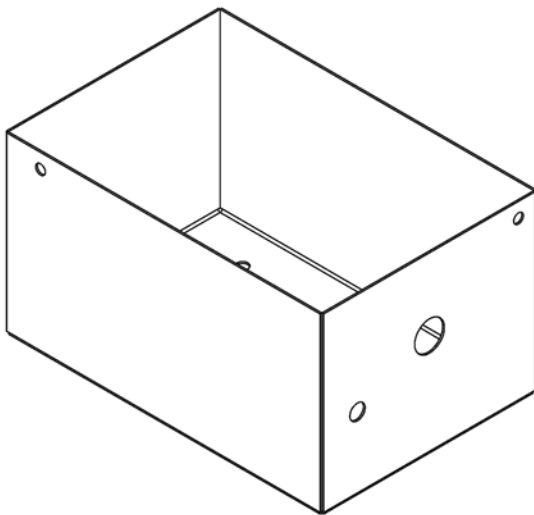

**Transformer Mounting Box**  
05700-002-10-01

**Transformer Mounting Box Top (not shown)**  
05700-000-78-53

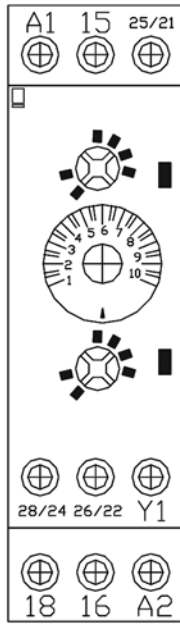

**Delay Timer**  
05945-011-65-44

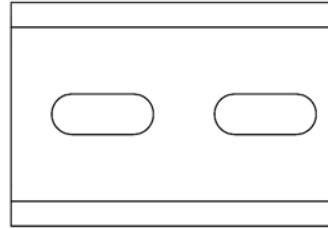

**2" Din Rail**  
05700-002-36-09

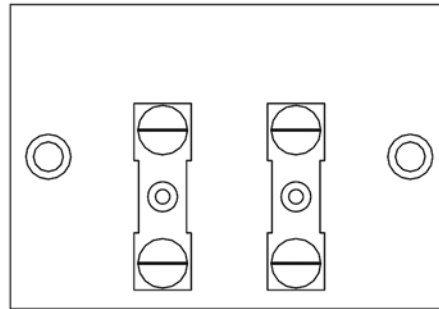

**Terminal Board**  
05940-011-84-41

## TEMPSTAR EXHAUST FAN HOOKUP

### LEGEND

T     TIMER  
TB    TERMINAL BOARD

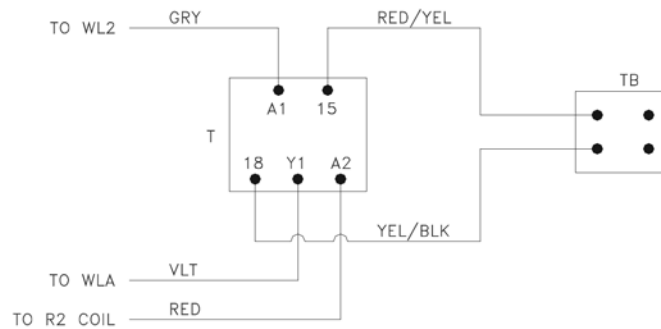

9905-002-54-41

# PARTS

## TEMPSTAR HH VENTLESS HEAT RECOVERY SYSTEM ASSEMBLY

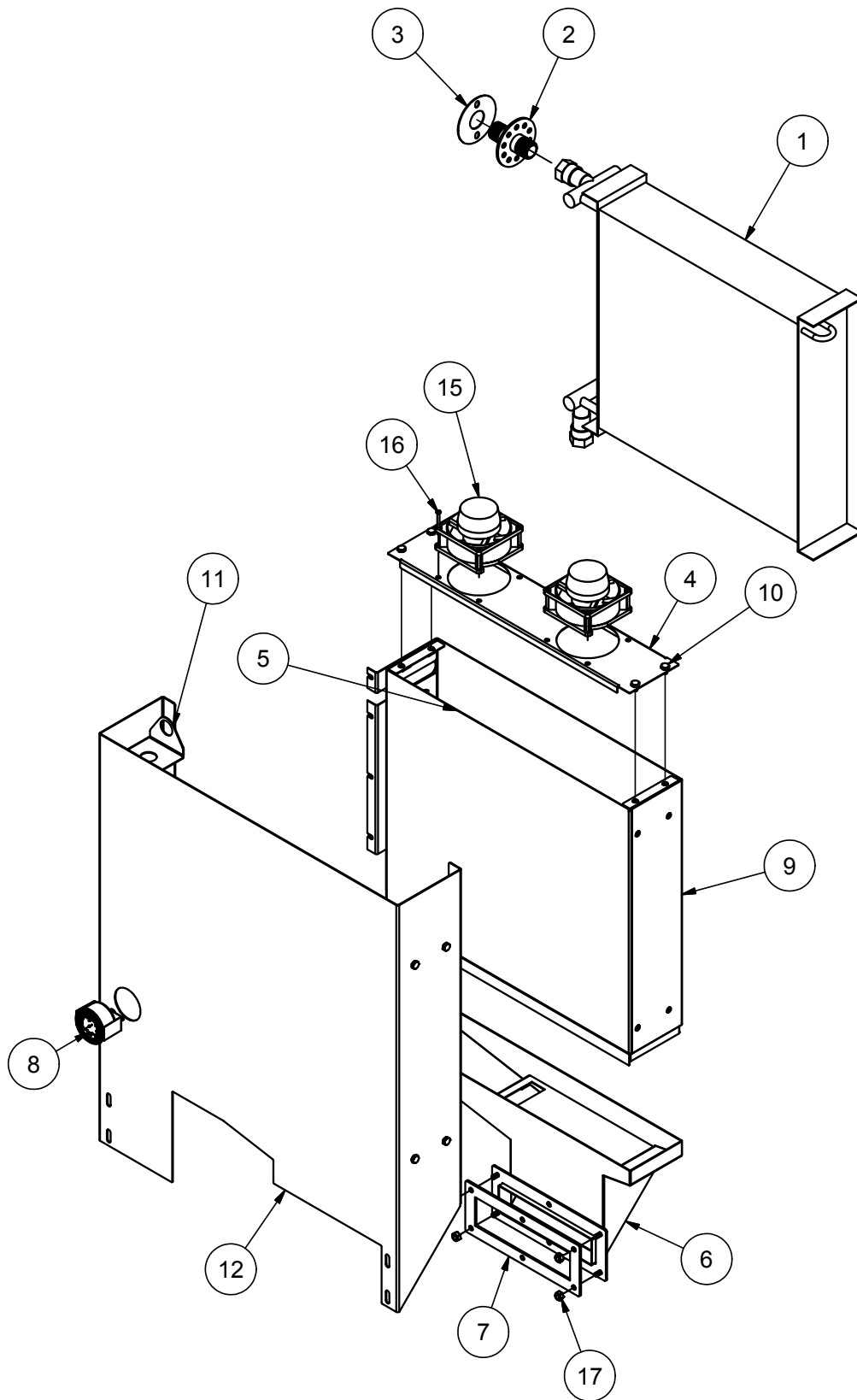

**PARTS***TEMPSTAR HH VENTLESS HEAT RECOVERY SYSTEM ASSEMBLY*

<b>ITEM</b>	<b>QTY</b>	<b>WasherDESCRIPTION</b>	<b>PART NUMBER</b>
1	1	Coil, Heat Exchanger	04420-004-19-61
2	1	Inlet, Cold Water	05700-004-19-01
3	1	Ring, Water Inlet	05700-004-19-24
4	1	Plate, Fan Mounting	05700-004-18-07
5	1	Upper Shroud	05700-004-18-06
6	1	Exhaust Box	05700-004-18-04
7	1	Gasket, Heat Exchanger	05330-004-18-22
8	1	Gauge	06680-011-86-42
9	1	Coil Box Back	05700-004-18-03
10	12	Bolt, 1/4-20 X 3/8 Hex	05305-274-20-00
11	1	Bracket, Vacuum Breaker	05700-004-18-91
12	1	Shroud, Hear Exchanger	05700-004-18-92
13	6	Nut, Lock 10-24 S/S Hex w/ Nylon	05310-373-01-00
14	6	Washer, Flat	05311-173-02-00
15	2	Fan, 3.62 Square, 85-236V AC Corrosion Resistant	05999-004-19-46
16	8	Screw, 6-32 X 1 1/2 Long	05305-003-11-33
17	4	Nut, Lock 1/4-20 Hex Nylon Insert	05310-374-01-00

# PARTS

## TEMPSTAR HH VENTLESS DOOR INTERLOCK

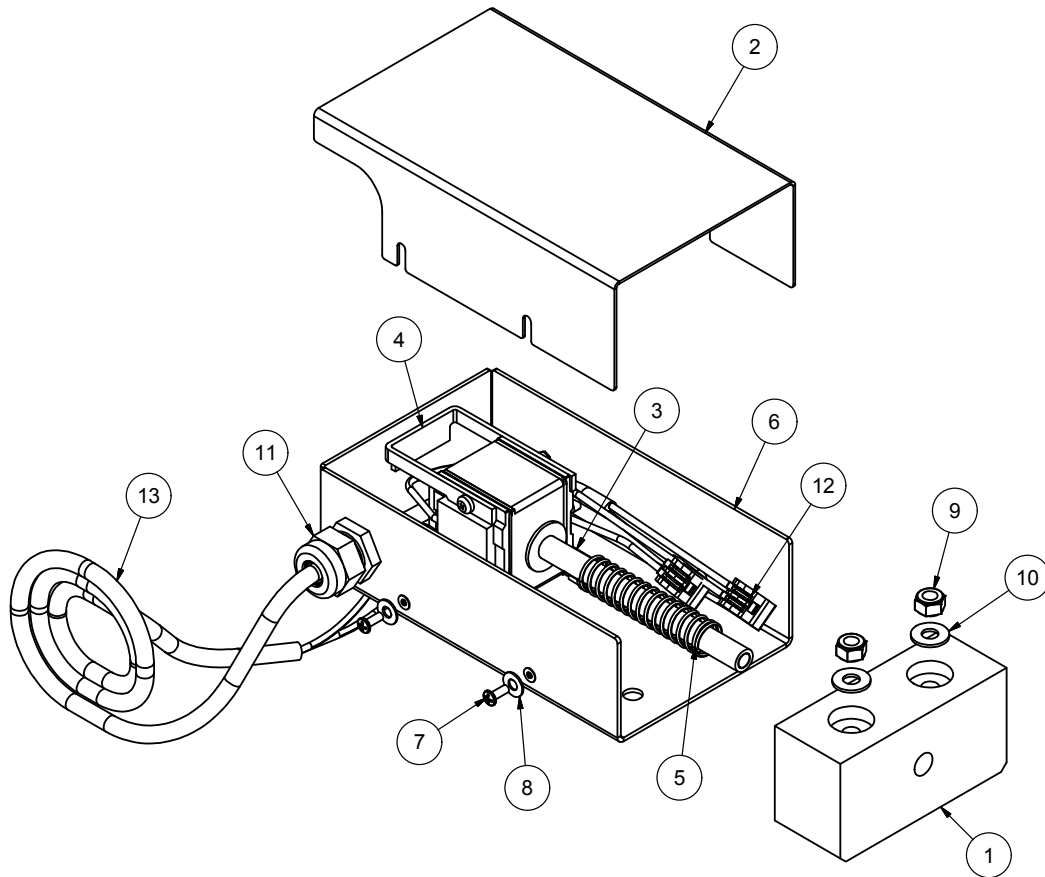

ITEM	QTY	DESCRIPTION	PART NUMBER
1	1	Guide Block, Door Lock	09330-004-22-72
2	1	F-Cover, Door Lock Mounting	05700-004-22-80
3	1	W-Rod, Interlock Weldment	05700-004-23-15
4	1	Soleniod, Horizontal 1" Push	04820-004-24-11
5	1	Spring, Comp.	05935-004-24-10
6	1	W-Base, Door Interlock Box	05700-004-24-25
7	8	Screw 3/8 Pan Head	05305-171-02-00
8	8	Washer, Flat #10	05311-173-02-00
9	2	Locknut, 1/4-20	05310-374-01-00
10	2	Washer, S/S 1/4-20 I.D.	05311-174-01-00
11	1	Fitg, 3216 Liqtite Blk	05975-011-59-50
12	2	Connector, 2-Conductor	05935-004-03-49
13	1	Cord, SJ 55" LG	05700-004-24-31



**SAFETY DOOR INTERLOCK/DOOR OVERRIDE INSTRUCTIONS**

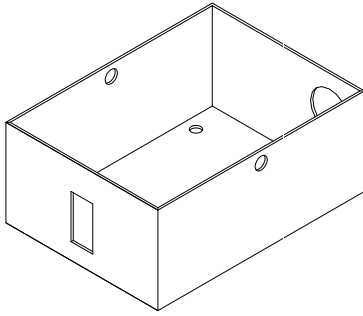

Safety Door Interlock Box Bottom  
05700-001-21-26

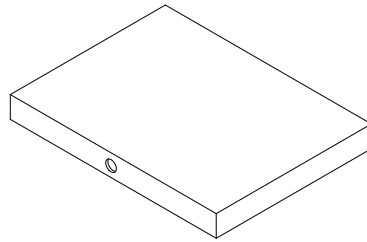

Safety Door Interlock Box Cover  
05700-001-21-27

Other Safety Door Interlock (SDI)  
components (not shown):

Pipe Clamp (found on the side of the machine)  
05700-000-35-05

Solenoid, Electrical Interlock Option  
04810-100-61-33

Relay  
05945-111-47-51

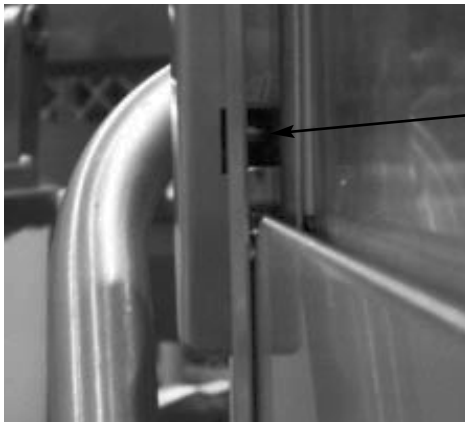

Latch access hole



The following instructions are for Tempstar HH models equipped with the Safety Door Interlock option. These instructions should only be used if the door interlock fails to unlatch and the doors are unable to be opened.

1. To manually disengage, find the latch access hole.
2. Gently insert the tip of a screwdriver or other metal utensil into the access hole, making contact with the latching arm.
3. Disengage the interlock by pushing the latching arm back with a minimal amount of force.
4. The doors should now open.

**TEMPSTAR SDI OPTION**

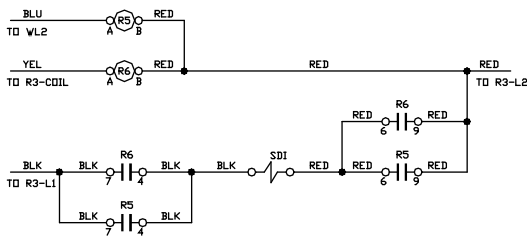

**LEGEND**

R5 RINSE RELAY  
R6 WASH RELAY  
SDI SAFETY DOOR INTERLOCK SOLENOID

09905-002-35-85a

**TEMPSTAR 460V SDI OPTION**

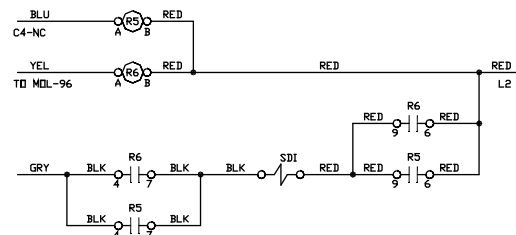

**LEGEND**

R5 RINSE RELAY  
R6 WASH RELAY  
SDI SAFETY DOOR INTERLOCK SOLENOID

# ELECTRICAL SCHEMATICS

SOLID STATE TEMPSTAR HH (TOP MOUNT CONTROLS), 208-230V, 60HZ, 1 & 3 PHASE

## LEGEND

- L1 L2 L3 POWER DISTRIBUTION BLOCK
- GND GROUND
- H1 RINSE HEATER
- H2 WASH HEATER
- M1 WASH MOTOR
- R1 RINSE HEATER CONTACTOR
- R2 WASH HEATER CONTACTOR
- R3 WASH MOTOR CONTACTOR
- R4 CONTROL RELAY
- F1 CONSTANT VOLTAGE CONNECTION
- F2 DETERGENT DISPENSER FUSE BLOCK
- F3 RINSE DISPENSER FUSE BLOCK
- F4 EXHAUST FAN FUSE BLOCK
- S1 POWER SWITCH
- S2 DOOR SWITCH
- S3 AUTO/MANUAL (DELIME) SWITCH
- S4 CYCLE SELECTOR
- E1 POWER LIGHT
- E2 HEATER OVERLOAD LIGHT
- E3 CYCLE LIGHT
- HLTS WASH HEATER HIGH LIMIT
- TS1 RINSE HEATER THERMOSTAT
- TS2 WASH HEATER THERMOSTAT
- HP HIGH WATER LEVEL PROBE
- WL WATER LEVEL CONTROL
- FS RINSE/FILL SOLENOID
- TB TIMER BOARD
- TM EXHAUST FAN TIMER
- PB1 RINSE TEMP PROBE
- PB2 WASH TEMP PROBE
- RF RECOVERY FANS
- DI DOOR INTERLOCK

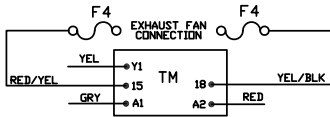
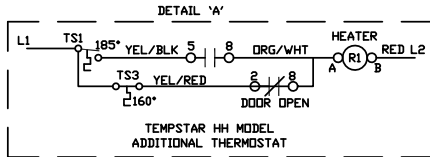
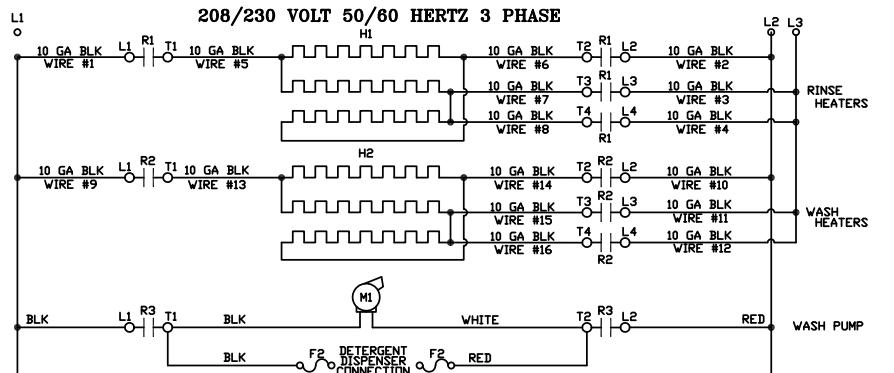
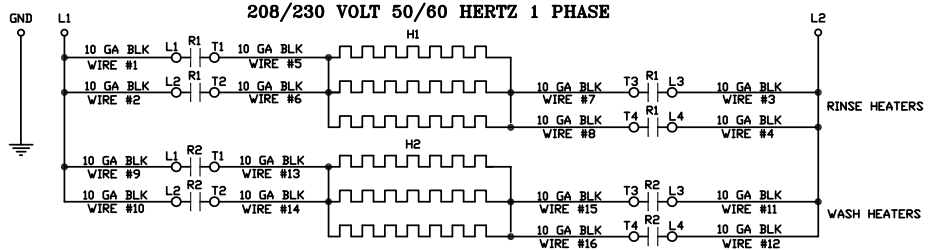

### CONTROL BOX LAYOUT

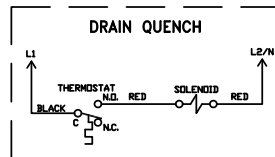
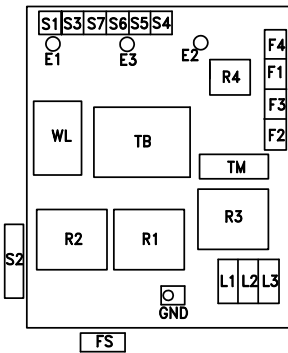

### DIP SWITCH SETTINGS

TEMPSTAR							
ON	1	2	3	4	5	6	7
↑	0	0	0	0	0	X	X

TEMPSTAR HH							
ON	1	2	3	4	5	6	7
↑	0	X	X	X	0	0	0

WITH HEAT RECOVERY							
ON	1	2	3	4	5	6	7
↑	X	0	0	0	0	X	X

HH WITH HEAT RECOVERY							
ON	1	2	3	4	5	6	7
↑	X	0	0	0	X	X	X

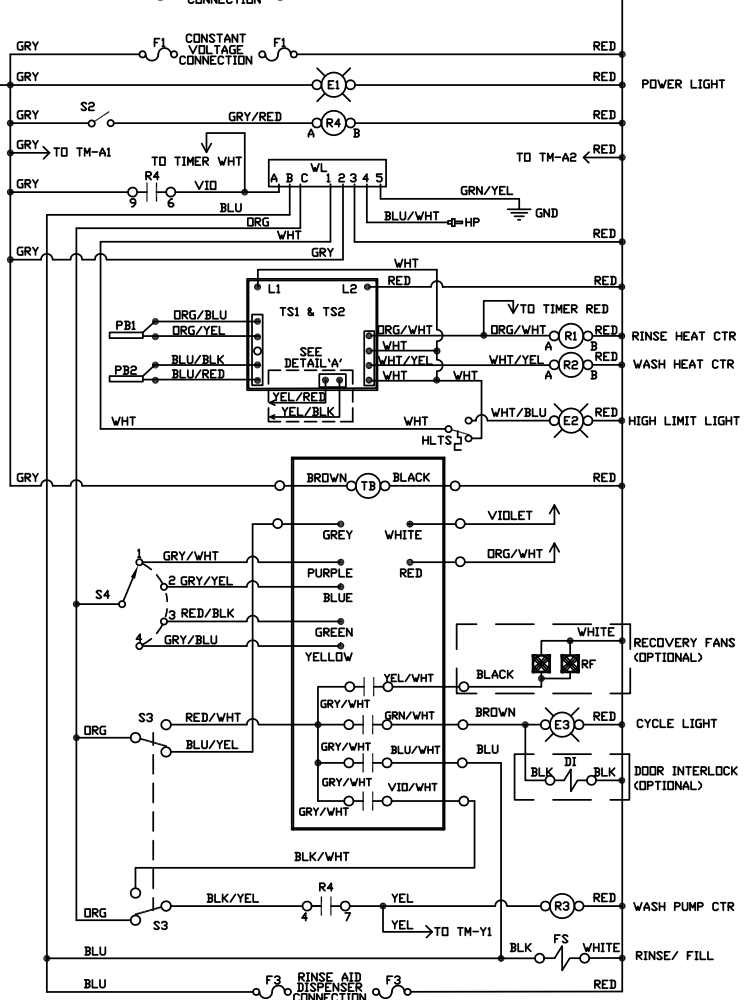

# ELECTRICAL SCHEMATICS

TEMPSTAR HH (UNIVERSAL TIMER), 208-230V, 60HZ, 1 & 3 PHASE

## LEGEND

L1	L2	L3	RINSE HEATER
GND			GROUND
H1			RINSE HEATER
H2			WASH HEATER
M1			WASH MOTOR
R1			RINSE HEATER CONTACTOR
R2			WASH HEATER CONTACTOR
R3			WASH MOTOR CONTACTOR
R4			CONTROL RELAY
F1			DISPENSER FUSE BLOCK
S1			POWER SWITCH
S2			DOOR SWITCH
S3			AUTO/MANUAL (DELIME) SWITCH
S4			CYCLE SELECTOR
E1			POWER LIGHT
E2			HEATER OVERLOAD LIGHT
E3			CYCLE LIGHT
HLTS			WASH HEATER HIGH LIMIT THERMOSTAT
TS1			RINSE HEATER THERMOSTAT 1
TS2			WASH HEATER THERMOSTAT
TS3			RINSE HEATER THERMOSTAT 2
HP			HIGH WATER LEVEL PROBE
WL			WATER LEVEL CONTROL
FS			RINSE/FILL SOLENOID
TB			TIMER BOARD

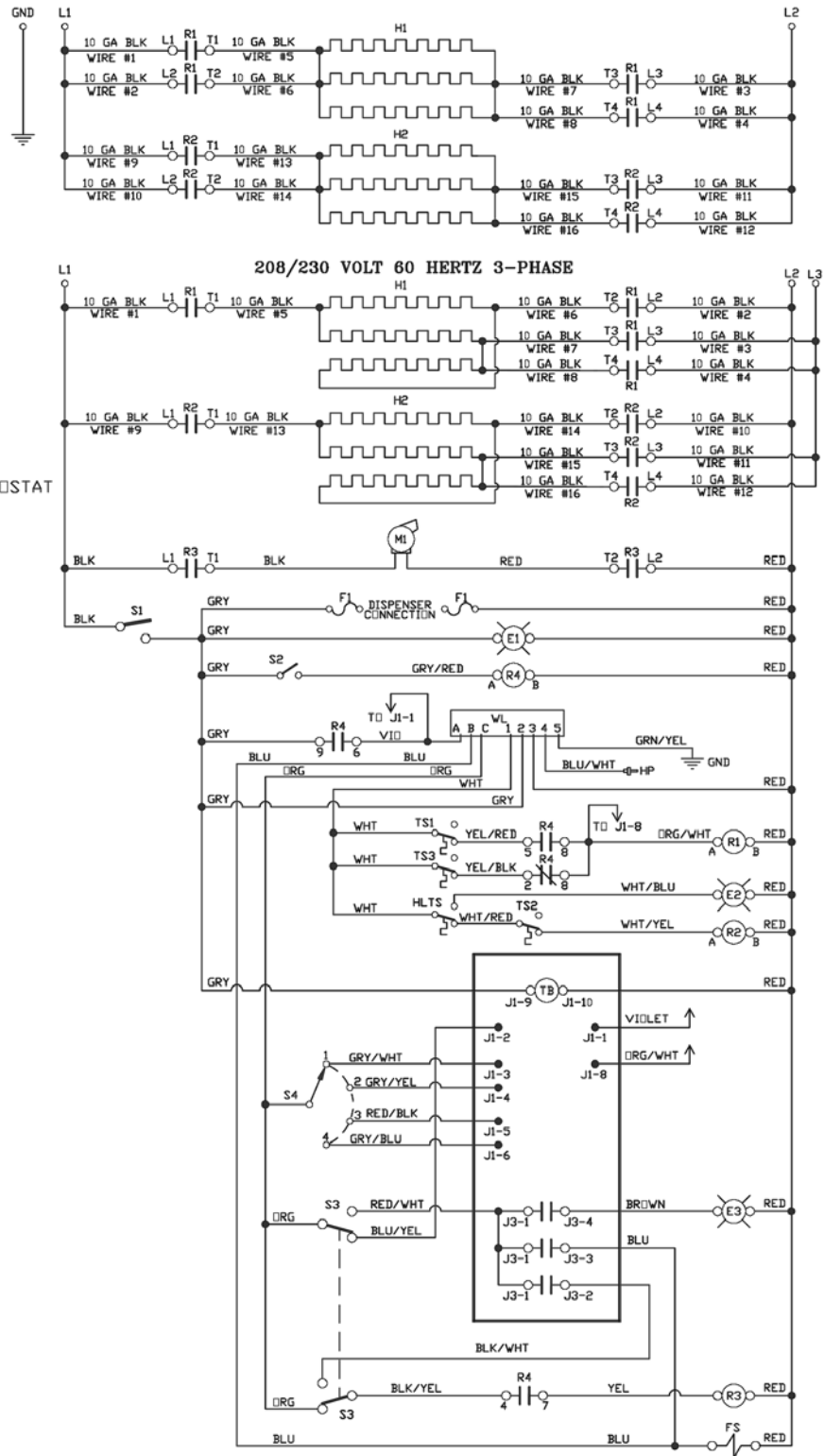

# ELECTRICAL SCHEMATICS

SOLID STATE TEMPSTAR HH (TOP MOUNT W/CYCLE SWITCHES), 460V, 60HZ, 3 PHASE

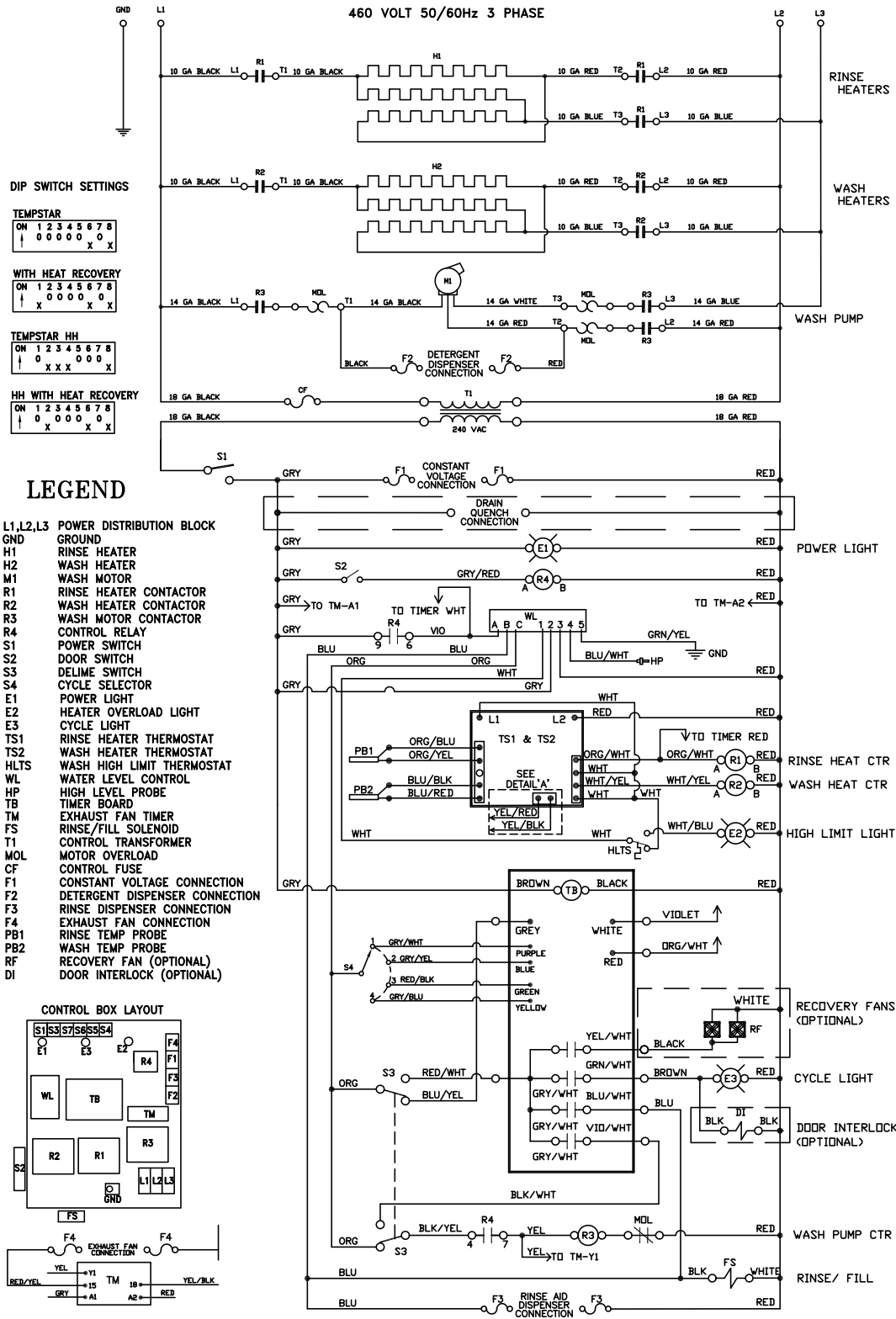

09905-003-30-67G

# ELECTRICAL SCHEMATICS

TEMPSTAR HH (UNIVERSAL TIMER), 460V, 60HZ, 3 PHASE

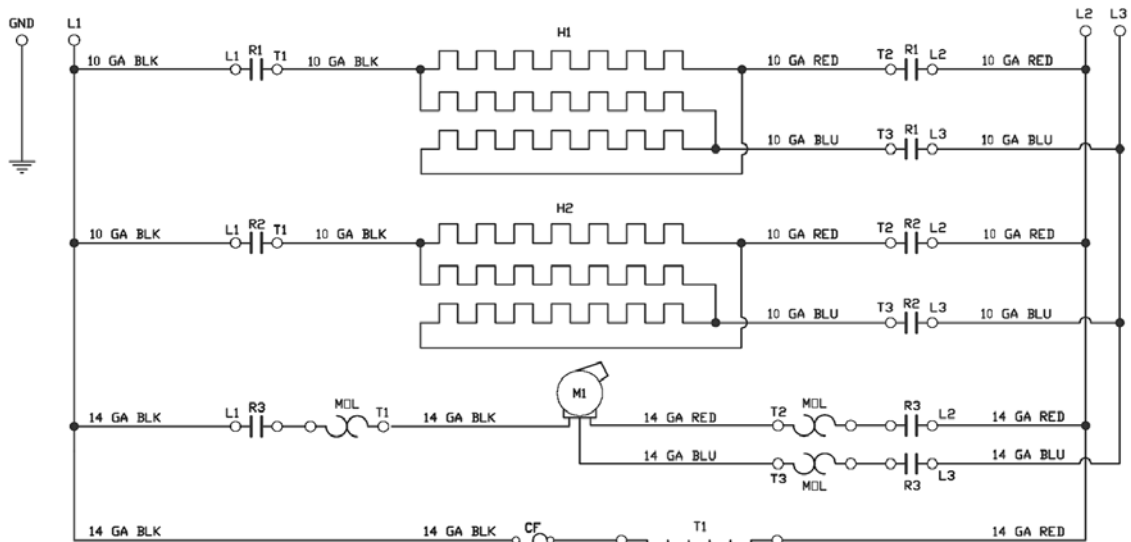

## LEGEND

- H1 RINSE HEATER
- H2 WASH HEATER
- M1 WASH MOTOR
- R1 RINSE HEATER CONTACTOR
- R2 WASH HEATER CONTACTOR
- R3 WASH MOTOR CONTACTOR
- R4 CONTROL RELAY
- F1 DISPENSER FUSE BLOCK
- S1 POWER SWITCH
- S2 DOOR SWITCH
- S3 AUTO/MANUAL (DELIME) SWITCH
- S4 CYCLE SELECTOR
- E1 POWER LIGHT
- E2 HEATER OVERLOAD LIGHT
- E3 CYCLE LIGHT
- HLTS WASH HEATER HIGH LIMIT THERMOSTAT
- TS1 RINSE HEATER THERMOSTAT 1
- TS2 WASH HEATER THERMOSTAT
- TS3 RINSE HEATER THERMOSTAT 2
- GND GROUND
- HP HIGH WATER LEVEL PROBE
- WL WATER LEVEL CONTROL
- FS RINSE/FILL SOLENOID
- CF CONTROL FUSE
- T1 CONTROL TRANSFORMER
- MOL MOTOR OVERLOAD
- TB TIMER BOARD

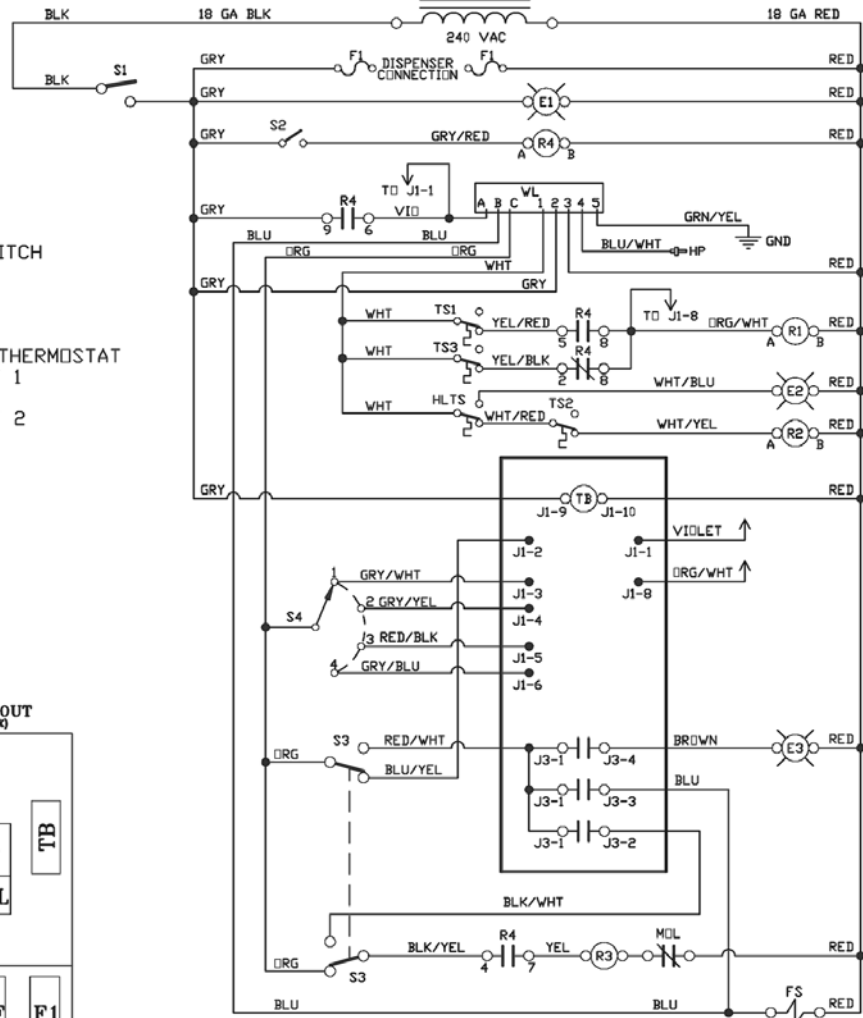

COMPONENT LAYOUT  
(TOP OF CONTROL BOX)

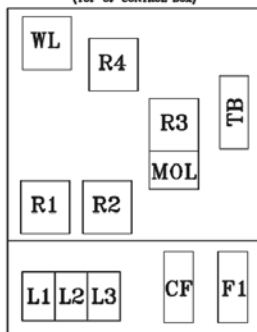

# ELECTRICAL SCHEMATICS

TEMPSTAR HH S (UNIVERSAL TIMER), 208-230V, 60HZ, 1 & 3 PHASE

## LEGEND

- L1 L2 L3 POWER DISTRIBUTION BLOCK
- M1 WASH MOTOR
- R3 WASH MOTOR CONTACTOR
- R4 CONTROL RELAY
- F1 DISPENSER FUSE BLOCK
- S1 POWER SWITCH
- S2 DOOR SWITCH
- S3 AUTO/MANUAL (DELIME) SWITCH
- S4 CYCLE SELECTOR
- E1 POWER LIGHT
- E3 CYCLE LIGHT
- TS1 STEAM THERMOSTAT
- GND GROUND
- HP HIGH WATER LEVEL PROBE
- WL WATER LEVEL CONTROL
- TB TIMER BOARD
- FS RINSE/FILL SOLENOID
- SS STEAM SOLENOID

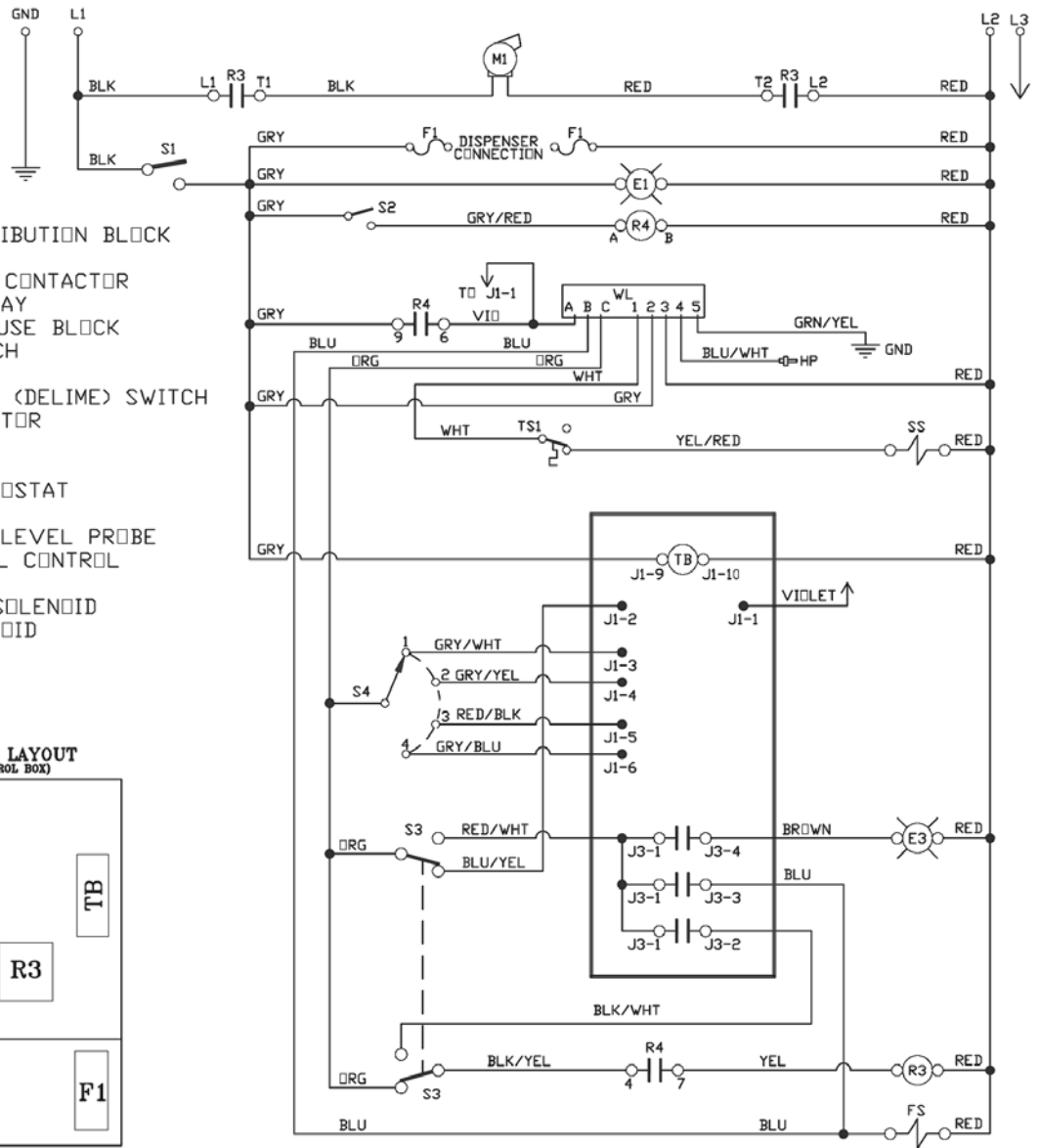
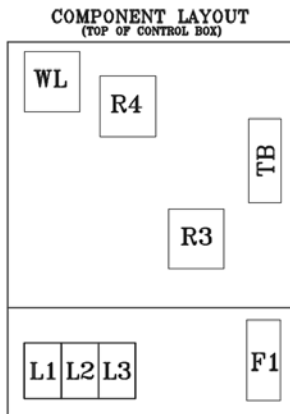

# ELECTRICAL SCHEMATICS

TEMPSTAR HH 208-230V, 60HZ, 1 & 3 PHASE

## LEGEND

- H1 RINSE HEATER
- H2 WASH HEATER
- M1 WASH MOTOR
- R1 RINSE HEATER CONTACTOR
- R2 WASH HEATER CONTACTOR
- R3 WASH MOTOR CONTACTOR
- R4 CONTROL RELAY
- F1 DISPENSER FUSE BLOCK
- S1 POWER SWITCH
- S2 DOOR SWITCH
- S3 AUTO/MANUAL (DELIME) SWITCH
- S4 CYCLE SELECTOR SWITCH
- C1 CYCLE SWITCH
- C2 AUTO START RESET SWITCH
- C3 WASH CYCLE SWITCH
- C4 RINSE/FILL SWITCH
- E1 POWER LIGHT
- E2 HEATER OVERLOAD LIGHT
- E3 CYCLE LIGHT
- HLTS WASH HEATER HIGH LIMIT THERMOSTAT
- TS1 RINSE HEATER THERMOSTAT
- TS2 WASH HEATER THERMOSTAT
- GND GROUND
- HP HIGH WATER LEVEL PROBE
- WL WATER LEVEL CONTROL
- TM TIMER MOTOR
- FS RINSE/FILL SOLENOID
- WCT WASH CYCLE TIMER
- PB1 RINSE THERMOSTAT PROBE
- PB2 WASH THERMOSTAT PROBE

208/230 VOLT 60 HERTZ 1 PHASE

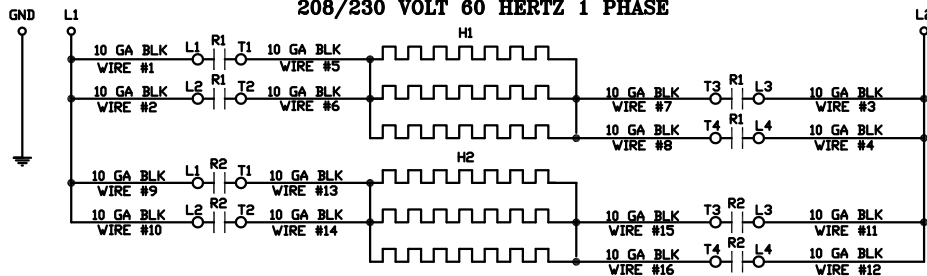

208/230 VOLT 60 HERTZ 3-PHASE

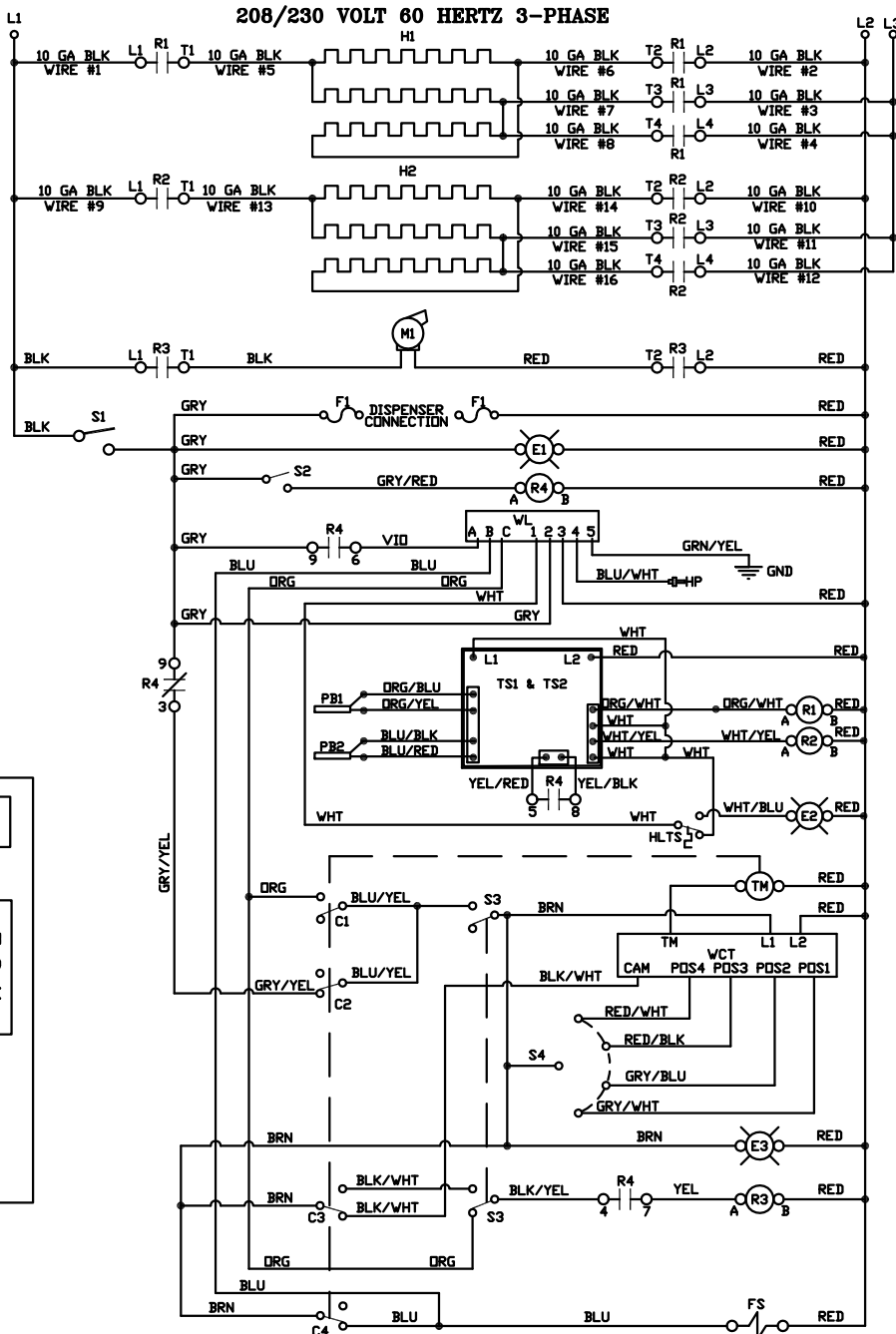

COMPONENT LAYOUT  
(TOP OF CONTROL BOX)

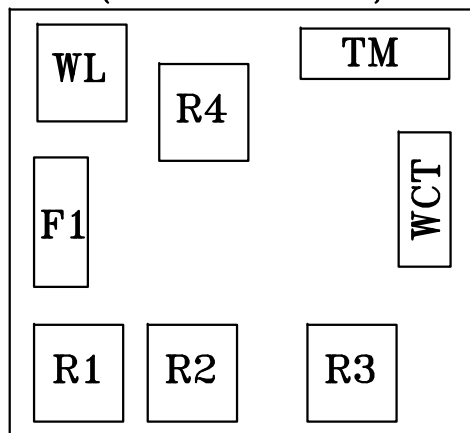

# ELECTRICAL SCHEMATICS

TEMPSTAR HH, 460V, 60HZ, 3 PHASE

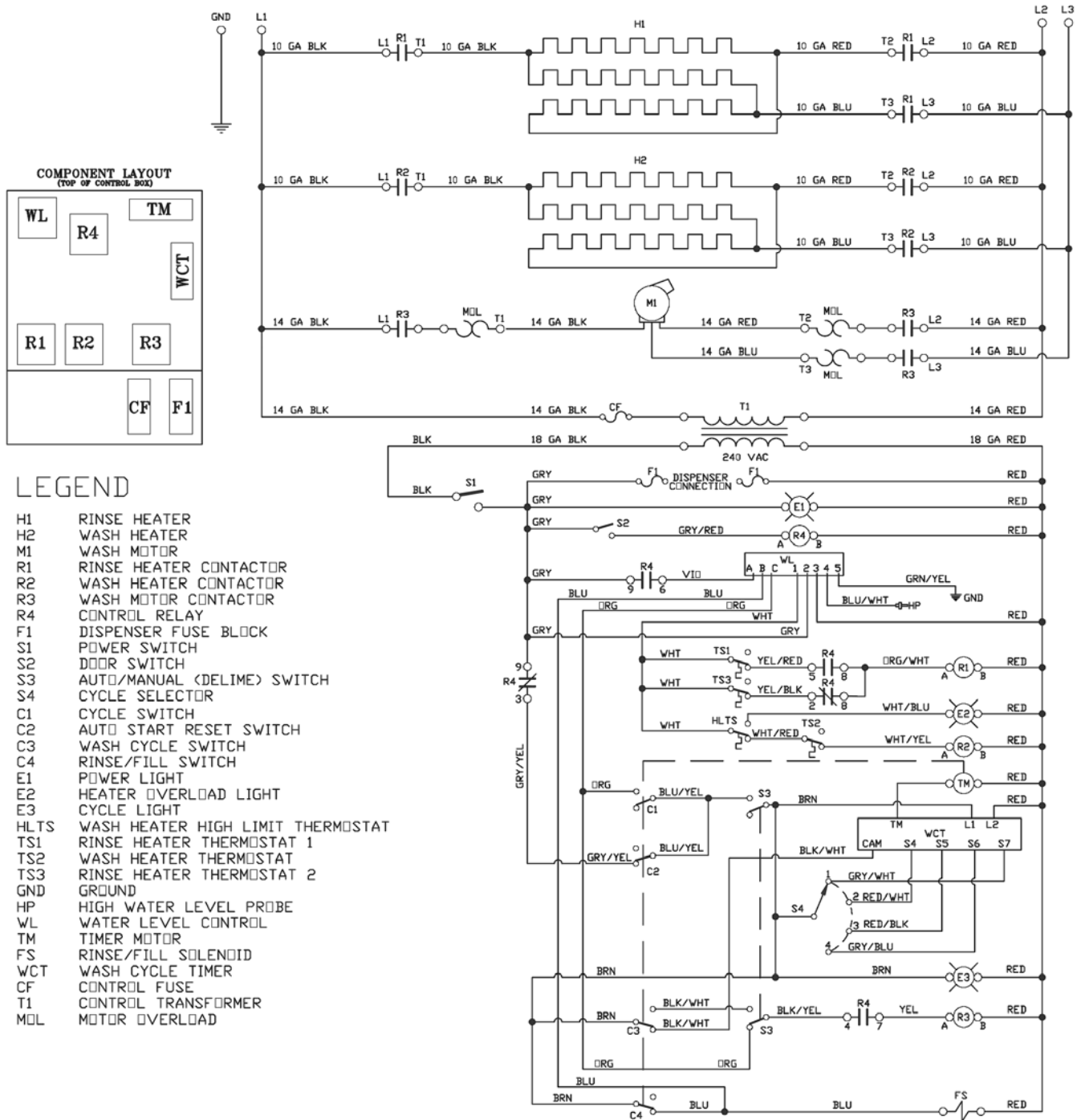



# ELECTRICAL SCHEMATICS

TEMPSTAR HH S, 208-230V, 60HZ, 1 & 3 PHASE

## LEGEND

L1 L2 L3	POWER DISTRIBUTION BLOCK
M1	WASH MOTOR
R3	WASH MOTOR CONTACTOR
R4	CONTROL RELAY
F1	DISPENSER FUSE BLOCK
S1	POWER SWITCH
S2	DOOR SWITCH
S3	AUTO/MANUAL (DELIME) SWITCH
S4	CYCLE SELECTOR
C1	CYCLE SWITCH
C2	AUTO START RESET SWITCH
C3	WASH CYCLE SWITCH
C4	RINSE/FILL SWITCH
E1	POWER LIGHT
E3	CYCLE LIGHT
TS1	STEAM THERMOSTAT
GND	GROUND
HP	HIGH WATER LEVEL PROBE
WL	WATER LEVEL CONTROL
TM	TIMER MOTOR
FS	RINSE/FILL SOLENOID
SS	STEAM SOLENOID
WCT	WASH CYCLE TIMER

## COMPONENT LAYOUT (TOP OF CONTROL BOX)

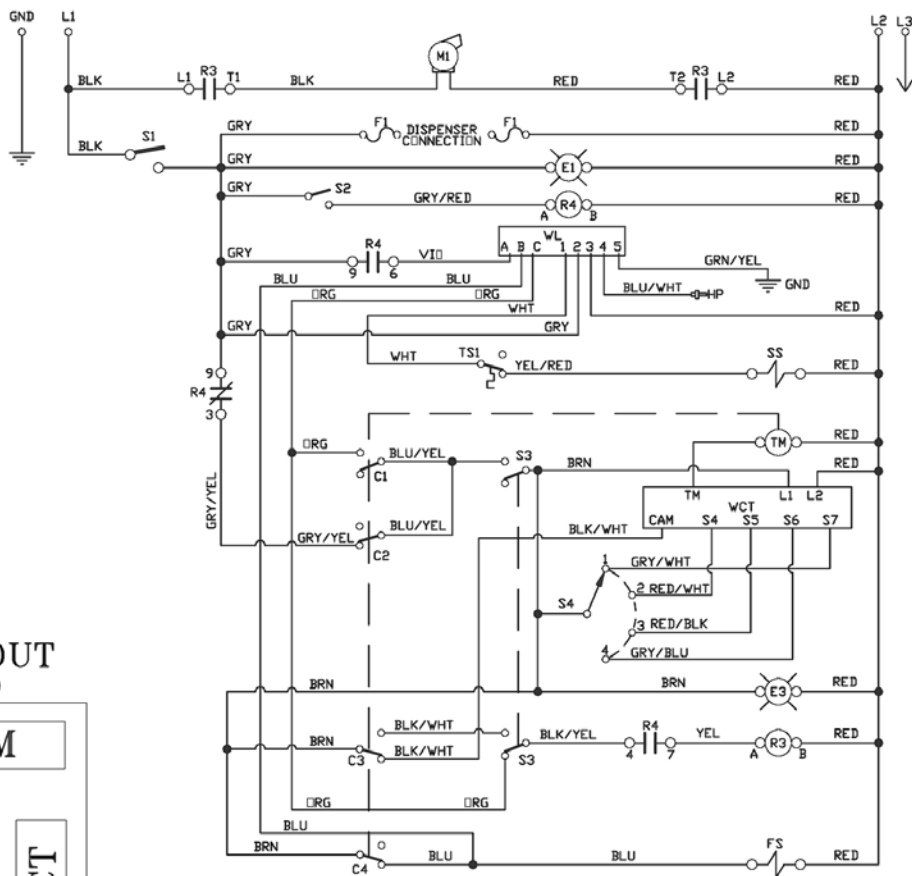
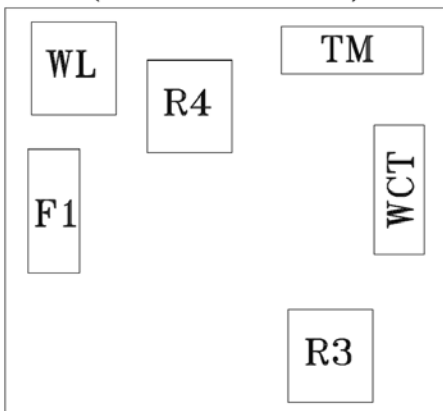

# ELECTRICAL SCHEMATICS

TEMPSTAR HH, NB 208V-230V, 50/60HZ, 1 PHASE

## TEMPSTAR HH NB SINGLE CYCLE ELECTRICAL DIAGRAM

208/230 VOLT 50/60 HERTZ SINGLE PHASE

### LEGEND

- L1 L2 L3 POWER DISTRIBUTION BLOCK
- GND GROUND
- H1 WASH HEATER
- M1 WASH MOTOR
- R1 WASH HEATER CONTACTOR
- R2 WASH MOTOR CONTACTOR
- R3 CONTROL RELAY
- S1 POWER SWITCH
- S2 DOOR SWITCH
- S3 DELIME SWITCH
- E1 POWER LIGHT
- E2 HEATER OVERLOAD LIGHT
- E3 CYCLE LIGHT
- TS1 WASH HEATER THERMOSTAT
- HLTS WASH HIGH LIMIT THERMOSTAT
- WL WATER LEVEL CONTROL
- HP HIGH LEVEL PROBE
- TM TIMER MOTOR
- C1 CYCLE SWITCH
- C2 AUTO START RESET SWITCH
- C3 WASH CYCLE SWITCH
- C4 RINSE/FILL SWITCH
- RS RINSE FILL SOLENOID
- FS DISPENSER FUSE BLOCK
- PB2 WASH TEMP PROBE

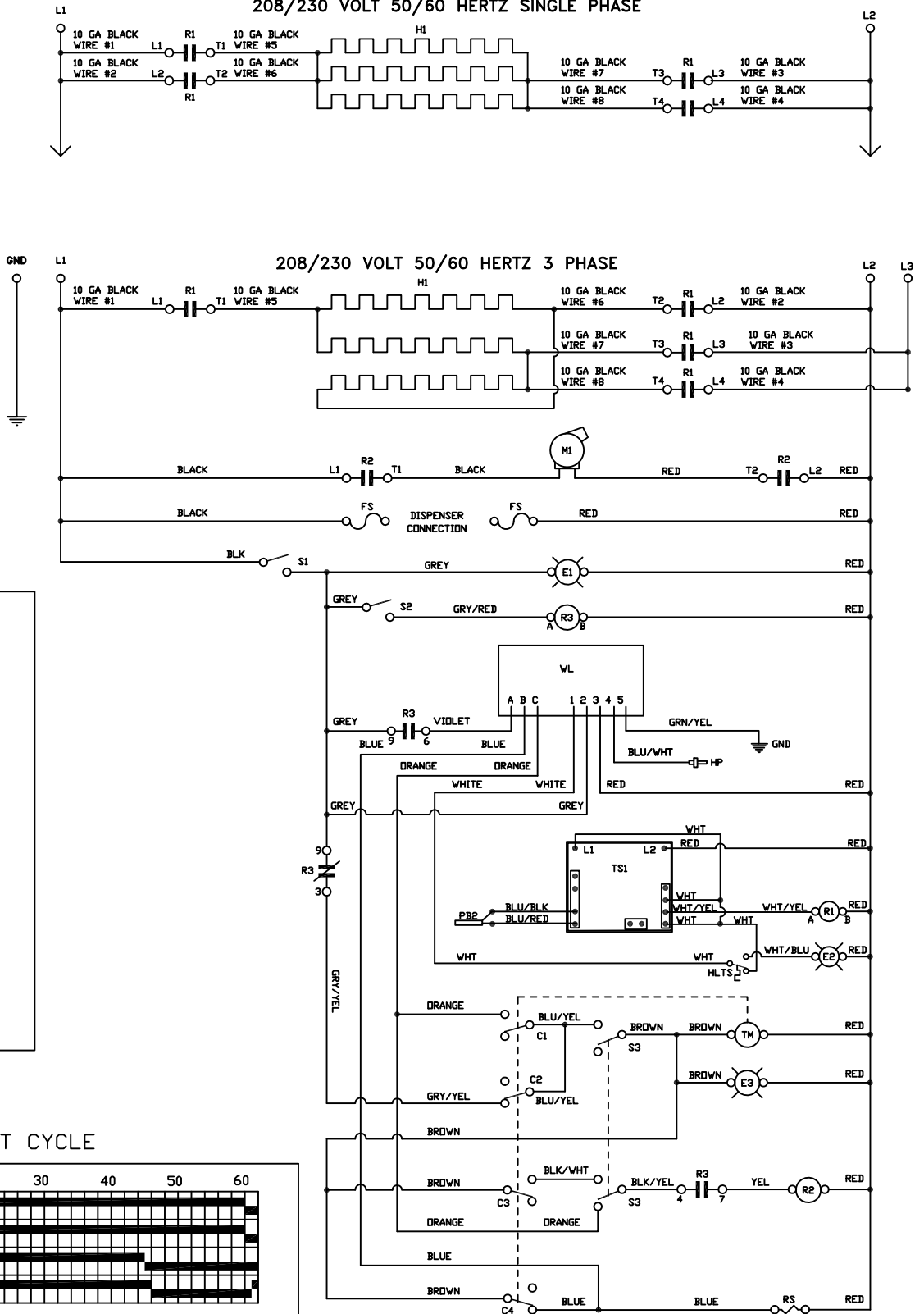

### CONTROL BOX LAYOUT

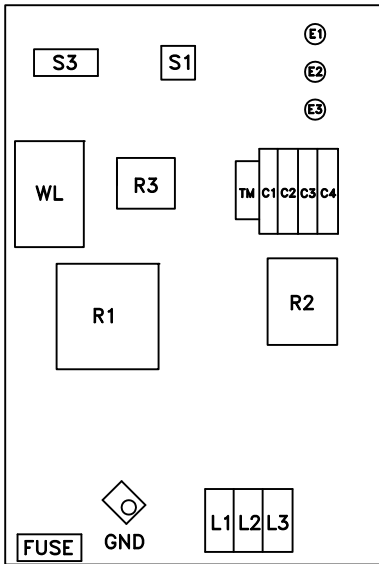

### TIMING CHART CYCLE

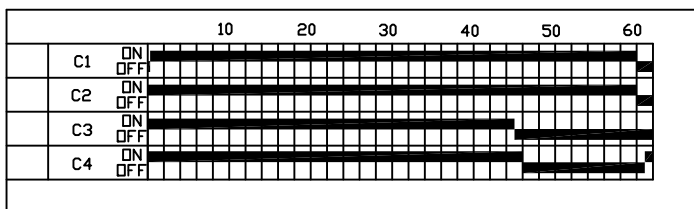

### TEMPSTAR NB/LT & TEMPSTAR HH NB/LT ELECTRICAL DIAGRAM

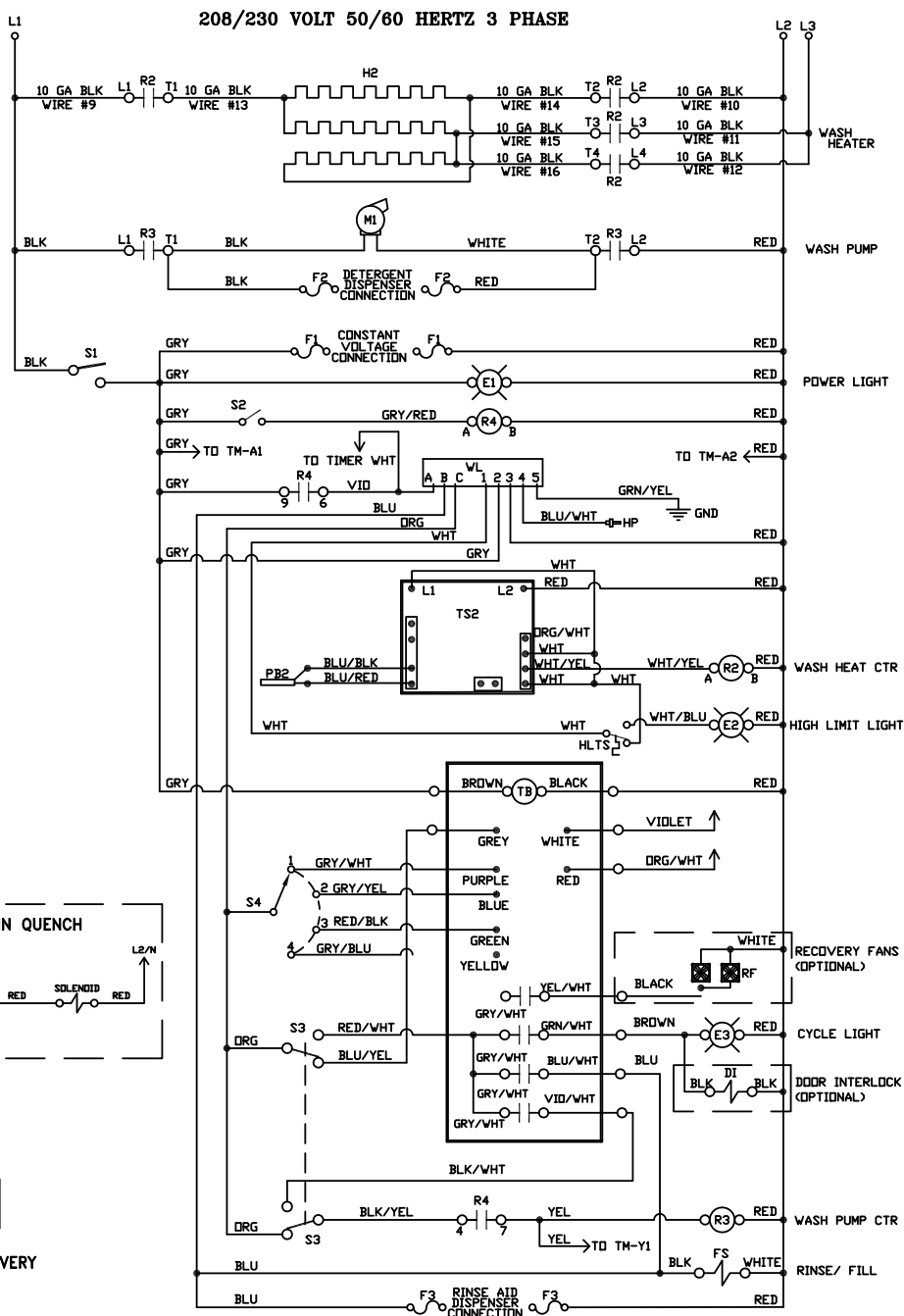
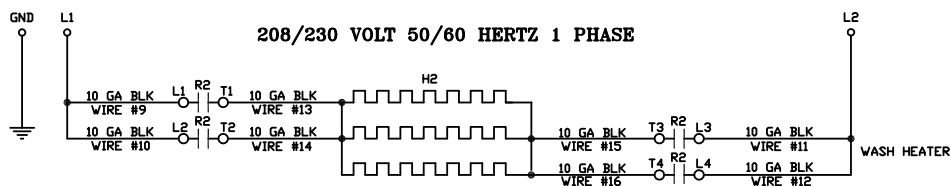

#### LEGEND

- L1 L2 L3 POWER DISTRIBUTION BLOCK
- GND GROUND
- H2 WASH HEATER
- M1 WASH MOTOR
- R2 WASH HEATER CONTACTOR
- R3 WASH MOTOR CONTACTOR
- R4 CONTROL RELAY
- F1 CONSTANT VOLTAGE CONNECTION
- F2 DETERGENT DISPENSER FUSE BLOCK
- F3 RINSE DISPENSER FUSE BLOCK
- F4 EXHAUST FAN FUSE BLOCK
- S1 POWER SWITCH
- S2 DOOR SWITCH
- S3 AUTO/MANUAL (DELIME) SWITCH
- S4 CYCLE SELECTOR
- E1 POWER LIGHT
- E2 HEATER OVERLOAD LIGHT
- E3 CYCLE LIGHT
- HLTS WASH HEATER HIGH LIMIT
- TS2 WASH HEATER THERMSTAT
- HP HIGH WATER LEVEL PROBE
- WL WATER LEVEL CONTROL
- FS RINSE/FILL SOLENOID
- TB TIMER BOARD
- TM EXHAUST FAN TIMER
- PB2 WASH TEMP PROBE
- RF RECOVERY FANS
- DI DOOR INTERLOCK

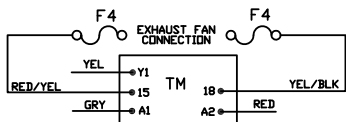

#### CONTROL BOX LAYOUT

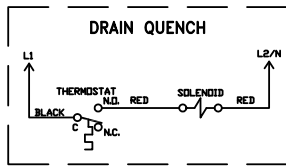
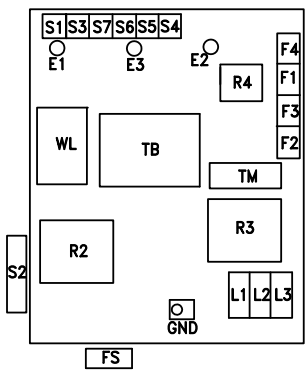

#### DIP SWITCH SETTINGS

TEMPSTAR	ON	1	2	3	4	5	6	7	8
	↑	0	0	0	0	0	0	X	X

TEMPSTAR HH	ON	1	2	3	4	5	6	7	8
	↑	0	X	X	X	0	0	0	0

WITH HEAT RECOVERY	ON	1	2	3	4	5	6	7	8
	↑	X	0	0	0	0	0	X	X

HH WITH HEAT RECOVERY	ON	1	2	3	4	5	6	7	8
	↑	0	X	0	0	0	0	X	X

# ELECTRICAL SCHEMATICS: OPTIONS

## SDI OPTION

### TEMPSTAR SDI OPTION

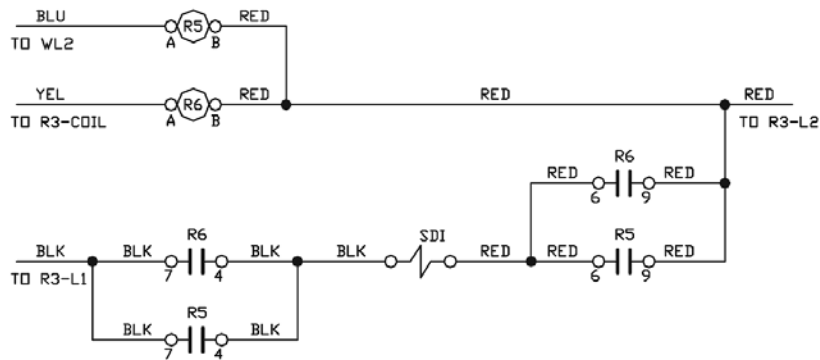

### LEGEND

- R5 RINSE RELAY
- R6 WASH RELAY
- SDI SAFETY DOOR INTERLOCK SOLENOID

09905-002-35-85a

### TEMPSTAR SDI OPTION

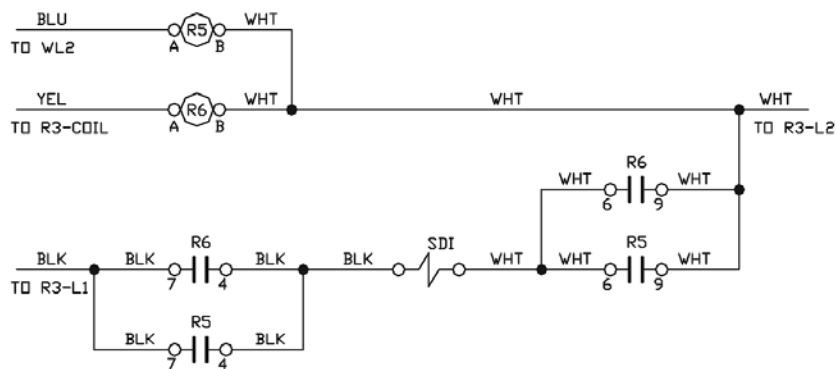

### LEGEND

- R5 RINSE RELAY
- R6 WASH RELAY
- SDI SAFETY DOOR INTERLOCK SOLENOID

09905-002-55-78a

## DRAIN QUENCH SYSTEM

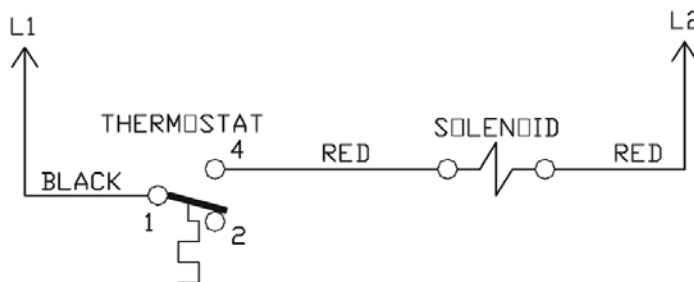

CONNECT BLACK WIRE TO MOTOR CONTACTOR - L1 WITH PIGGYBACK TERMINAL PROVIDED

CONNECT WHITE WIRE TO MOTOR CONTACTOR - L2 WITH PIGGYBACK TERMINAL PROVIDED

