

INSTALLATION/OPERATION & TECHNICAL MANUAL

ELECTRICALLY HEATED MODELS:

TEMPSTAR

TEMPSTAR LT

TEMPSTAR NB

TEMPSTAR SDS

STEAM HEATED MODELS:

TEMPSTAR S



MANUFACTURERS WARRANTY

ONE YEAR LIMITED PARTS & LABOR WARRANTY

ALL NEW JACKSON DISHWASHERS ARE WARRANTED TO THE ORIGINAL PURCHASER TO BE FREE FROM DEFECTS IN MATERIAL OR WORKMANSHIP, UNDER NORMAL USE AND OPERATION FOR A PERIOD OF (1) ONE YEAR FROM THE DATE OF PURCHASE, BUT IN NO EVENT TO EXCEED (18) EIGHTEEN MONTHS FROM THE DATE OF SHIPMENT FROM THE FACTORY.

Jackson MSC agrees under this warranty to repair or replace , at its discretion, any original part which fails under normal use due to faulty material or workmanship during the warranty period, providing the equipment has been unaltered, and has been properly installed, maintained and operated in accordance with the applicable factory instruction manual furnished with the machine and the failure is reported to the authorized service agency within the warranty period. This includes the use of factory specified genuine replacement parts, purchased directly from a Jackson authorized parts distributor or service agency. Use of generic replacement parts may create a hazard and void warranty certification.

The labor to repair or replace such failed part will be paid by Jackson MSC, within the continental United States, Hawaii and Canada, during the warranty period provided a Jackson MSC authorized service agency, or those having prior authorization from the factory, performs the service. Any repair work by persons other than a Jackson MSC authorized service agency is the sole responsibility of the customer. Labor coverage is limited to regular hourly rates, overtime premiums and emergency service charges will not be paid by Jackson MSC.

Accessory components not installed by the factory carry a (1) one year parts warranty only. Accessory components such as table limit switches, pressure regulators, pre rinse units, etc. that are shipped with the unit and installed at the site are included. Labor to repair or replace these components is not covered by Jackson MSC.

This warranty is void if failure is a direct result from shipping, handling, fire, water, accident, misuse, acts of god, attempted repair by unauthorized persons, improper installation, if serial number has been removed or altered, or if unit is used for purpose other than it was originally intended.

TRAVEL LIMITATIONS

Jackson MSC limits warranty travel time to (2) two hours and mileage to (100) one hundred miles. Jackson MSC will not pay for travel time and mileage that exceeds this, or any fees such as those for air or boat travel without prior authorization.

WARRANTY REGISTRATION CARD

The warranty registration card supplied with the machine must be returned to Jackson MSC within 30 days to validate the warranty.

REPLACEMENT PARTS WARRANTY

Jackson replacement parts are warranted for a period of 90 days from the date of installation or 180 days from the date of shipment from the factory, which ever occurs first.

PRODUCT CHANGES AND UPDATES

Jackson MSC reserves the right to make changes in design and specification of any equipment as engineering or necessity requires.

THIS IS THE ENTIRE AND ONLY WARRANTY OF JACKSON MSC. JACKSON'S LIABILITY ON ANY CLAIM OF ANY KIND, INCLUDING NEGLIGENCE, WITH RESPECT TO THE GOODS OR SERVICES COVERED HEREUNDER, SHALL IN NO CASE EXCEED THE PRICE OF THE GOODS OR SERVICES OR PART THEREOF WHICH GIVES RISE TO THE CLAIM.

THERE ARE NO WARRANTIES, EXPRESSED OR IMPLIED, INCLUDING FOR FITNESS OR MERCHANTABILITY, THAT ARE NOT SET FORTH HEREIN, OR THAT EXTEND BEYOND THE DURATION HEREOF. UNDER NO CIRCUMSTANCES WILL JACKSON MSC BE LIABLE FOR ANY LOSS OR DAMAGE, DIRECT OR CONSEQUENTIAL, OR FOR THE DAMAGES IN THE NATURE OF PENALTIES, ARISING OUT OF THE USE OR INABILITY TO USE ANY OF ITS PRODUCTS.

ITEMS NOT COVERED

This warranty does not cover cleaning or deliming of the unit or any component such as, but not limited to, wash arms, rinse arms or strainers at anytime. Nor does it cover adjustments such as, but not limited to timer cams, thermostats or doors, beyond 30 days from the date of installation. In addition, the warranty will only cover the replacement of wear items such as curtains, drain balls, door guides or gaskets during the first 30 days after installation. Also, not covered are conditions caused by the use of incorrect (non-Commercial) grade detergents, incorrect water temperature or pressure, or hard water conditions.



**CALL 1-888-800-5672 TO REGISTER THIS PRODUCT!
FAILURE TO DO SO WILL VOID THE WARRANTY!**

**LLAME AL 1-888-800-5672 PARA REGISTRAR ESTE PRODUCTO!
AL NO HACERLO LA GARANTIA SERA ANULADA!**

**S.V.P. APPELER 1-888-800-5672 POUR ENREGISTRER CE PRODUIT,
LA GARANTIE SERA ANNULEE POUR TOUT PRODUIT NON- ENREGISTREE**

REVISION	REVISION DATE	MADE BY	APPLICABLE ECN	DETAILS
F	05-14-04	MAW	6964 7006	Changed thermostat. Changed thermostat mounting bracket. Change to new layout. Added note for "wye configuration".
G	01-05-05	MAW	7084 6690 7180	Added Overflow Lift Brackets. Added Right False Panel Weldment used with overflow tube lifter. Added universal False Panel Weldment for Tempstars. Update Tempstar Top Mount 460V Schematic to revision D. Added "GO*BOX" Kit.
H	01-17-06	MAW	7609	Added schematics and parts for Universal Timers to be used in Top Mount Control Boxes Only.
I	02-07-06	MAW	7231	Added thermostat replacement kit 06401-011-66-55. Replaced rinse thermostat 05930-121-71-29 with 05930-510-03-79.
J	06-26-06	MAW	7687, 7540 7738, 7789 7571	Update to current layout. Added phase conversion instructions and service kits. Changed hood supports and added hood block spacers. Added numbers for plumbing assemblies. Updated drain quench assembly drawing. Replaced 05930-121-67-72 with 05930-510-02-79.
K	12-07-07	MAW	Process	Combined I/O & Technical manuals. Updated schematics to include exhaust fan/dispenser connections. Updated control boxes with multicycle switches. Corrected number for reed switch and cantilever support brackets.



TEMPSTAR NB

TEMPSTAR = Electrically heated, high temp, hot water sanitizing, with booster heater, door-type dish-machine

TEMPSTAR LT = Electrically heated, low temp, chemical sanitizing, no rinse booster, door-type dish-machine

TEMPSTAR NB = Electrically heated, high temp, hot water sanitizing, no rinse booster, door-type dish-machine

TEMPSTAR S = Steam heated, high temp, hot water sanitizing, door-type dishmachine

TEMPSTAR SDS = Electrically heated, high temp, with solid chemical dispenser, with booster heater, door-type dishmachine

Model: _____

Serial No.: _____

Installation Date: _____

Service Rep. Name: _____

Phone No.: _____

Jackson MSC LLC. provides technical support for all of the dishmachines detailed in this manual. We strongly recommend that you refer to this manual before making a call to our technical support staff. Please have this manual with you when you call so that our staff can refer you, if necessary, to the proper page. Technical support is available from 8:00 a.m. to 5:00 p.m. (EST), Monday through Friday. Technical support is not available on holidays. Contact technical support toll free at 1-888-800-5672. Please remember that technical support is available for service personnel only.

TABLE OF CONTENTS

<u>Section</u>	<u>Description</u>	<u>Page</u>
I.	Specifications	
	Operating Capacities	2
	Electrical Requirements	3
	Dimensions Tempstar/Tempstar LT/Tempstar NB (Side Mounted Control Box)	4
	Dimensions Tempstar/Tempstar LT/Tempstar NB (Top Mounted Control Box)	5
	Dimensions Tempstar SDS	6
	Table Dimensions	7
II.	Installation/Operation Instructions	
	Installation Instructions	9
	Electrical Installation Instructions	10
	Operation Instructions	11
	Detergent Control	12
	False Panel Installation	13
III.	Preventative Maintenance	15
IV.	Troubleshooting Section	17
V.	Drawing/Parts Section	
	Top Mounted Control Box Assembly (Universal Timer)	20
	Top Mounted Control Box Assembly (Mechanical Timer)	22
	Side Mounted Control Box Assembly	24
	SDS Control Box Assembly	26
	Hood Assembly	28
	Hood Assembly (Bolted Single Support Design)	29
	Cantilever Arm/Door Assemblies	30
	Tub Assembly	32
	Steam Tub Assembly	34
	Frame Assembly	36
	Rinse Tank Assembly	37
	Coil Assembly	38
	Incoming Steam Plumbing Assembly	39
	Wash Motors	40
	Motor & Pump Assembly	41
	Wash Heaters/Rinse Heaters	42
	Incoming Plumbing/Outlet Plumbing Assembly	43
	WPRK Kit Option	44
	Tempstar LT & Tempstar NB Incoming Plumbing Assembly	45
	Tempstar SDS Incoming Plumbing Assembly	46
	3/4" Solenoid Valve & 3/4" NPT Vacuum Breaker Repair Parts Kits	47
	Wash and Rinse Arm/Manifold Assemblies	48
	Tempstar SDS Dispenser Assembly	50
	Safety Door Interlock (SDI)/Exhaust Fan Control/Transformer Mounting Box Components	55
	False Panel Installation	56
	GO*BOX Kit	57
	Drain Quench Assembly	58

TABLE OF CONTENTS

VI.A	Electrical Diagrams - Top Mounted Control Boxes	
	Tempstar (UT w/Cycle Switches) 208 - 230V, 50/60 Hz, single/three phase	60
	Tempstar (UT w/Cycle Switches) 460V, 60 Hz, three phase	61
	Tempstar LT & NB (UT w/Cycle Switches) 208 - 230V, 50/60 Hz, single/three phase	62
	Tempstar LT & NB (UT w/Cycle Switches) 460V, 60 Hz, three phase	63
	Tempstar (Universal Timer) 208 - 230V, 50/60 Hz, single/three phase	64
	Tempstar (Universal Timer) 380/440/460V, 50/60 Hz, three phase	65
	Tempstar LT & NB (Universal Timer) 208 - 230V, 50/60 Hz, single/three phase	66
	Tempstar LT & NB (Universal Timer) 380/415/440/460V, 50/60 Hz, three phase	67
	Tempstar (Mechanical Timer) 208 - 230V, 50/60 Hz, single/three phase	68
	Tempstar (Mechanical Timer) 380/440/460V, 50/60 Hz, three phase	69
	Tempstar (Mechanical Timer) 415V, 50/60 Hz, three phase, five wire	70
	Tempstar LT & NB (Mechanical Timer) 208 - 230V, 50/60 Hz, single/three phase	71
	Tempstar LT & NB (Mechanical Timer) 380/415/440/460V, 50/60 Hz, three phase	72
	Tempstar S (Mechanical Timer) 208 - 230V, 60 Hz, single/three phase	73
	Tempstar S (Universal Timer) 208 - 230V, 60 Hz, single/three phase	74
VI.B	Electrical Diagrams - Side Mounted Control Boxes	
	Tempstar (Side Mount) 208 - 230V, 50/60 Hz, single/three phase	76
	Tempstar (Side Mount) 380V, 50 Hz, three phase	77
	Tempstar (Side Mount) 440/460V, 50/60 Hz, three phase	78
	Tempstar LT & Tempstar NB (Side Mount) 208 - 230V, 50/60 Hz, single/three phase	79
	Tempstar LT & Tempstar NB (Side Mount) 380/440/460V, 50/60 Hz, three phase	80
	Tempstar SDS 208 - 230V, 60 Hz, single/three phase	81
	Tempstar SDS 380/440/460V, 50/60 Hz, three phase	82
	Tempstar SDS 380/415V, 50 Hz, three phase, 5 wire	83
	Tempstar SDS Dispenser	85
VI.C	Electrical Diagram Options	
	Safety Door Interlock (SDI)	86
	Drain Quench	87
	Exhaust Fan Control	87
VII.	Jackson Maintenance & Repair Centers	89

SECTION 1: SPECIFICATION INFORMATION

SECTION 1: SPECIFICATION INFORMATION

OPERATING CAPACITIES

PERFORMANCE/CAPABILITIES

OPERATING CAPACITY:

RACKS PER HOUR	57
DISHES PER HOUR	1425
GLASSES PER HOUR	1425

OPERATING CYCLE (SECONDS):

MINIMUM (OTHER CYCLE TIMES ARE AVAILABLE)

WASH TIME	45
RINSE TIME	11
DWELL TIME	2
TOTAL CYCLE TIME	60

TANK CAPACITY:

WASH TANK (GAL)	8.0
WASH TANK (L)	30.3
RINSE TANK (TEMPSTAR/TEMPSTAR SDS) (GAL)	3.0
RINSE TANK (TEMPSTAR/TEMPSTAR SDS) (L)	11.4

STEAM REQUIREMENTS:

COIL SIZE	3/4"
STEAM FLOW PRESSURE (P.S.I.)	10-20
CONSUMPTION @ 15 P.S.I. (LBS/HR)	45

ELECTRICAL REQUIREMENTS

WASH MOTOR HP	3/4
---------------	-----

NOTE: Always refer to the machine data plate for specific electrical and water requirements. The material provided on this page is for reference only and may be subject to change without notice.

WATER REQUIREMENTS

TEMPSTAR/TEMPSTAR SDS:

WASH TEMPERATURE (MINIMUM)(°F)	150
WASH TEMPERATURE (MINIMUM)(°C)	66
RINSE TEMPERATURE (MINIMUM)(°F)	180
RINSE TEMPERATURE (MINIMUM)(°C)	83
INLET WATER TEMPERATURE:	
12KW RINSE HEATER (°F)	140
12KW RINSE HEATER (°C)	60
14KW RINSE HEATER (°F)	110
14KW RINSE HEATER (°C)	44
FLOW PRESSURE (PSI)	20 ± 5
WATER LINE SIZE (NPT)	3/4"
DRAIN LINE SIZE (NPT)	1 1/2"

TEMPSTAR LT:

WASH TEMPERATURE (MINIMUM)(°F)	130
WASH TEMPERATURE (MINIMUM)(°C)	55
RINSE TEMPERATURE (MINIMUM)(°F)	130
RINSE TEMPERATURE (MINIMUM)(°C)	55
INLET WATER TEMPERATURE (°F)	130
INLET WATER TEMPERATURE (°C)	55
FLOW PRESSURE (PSI)	20 ± 5
WATER LINE SIZE (NPT)	3/4"
DRAIN LINE SIZE (NPT)	1 1/2"
MINIMUM CHLORINE REQUIRED (PPM)	50

TEMPSTAR NB/TEMPSTAR S:

WASH TEMPERATURE (MINIMUM)(°F)	150
WASH TEMPERATURE (MINIMUM)(°C)	66
RINSE TEMPERATURE (MINIMUM)(°F)	180
RINSE TEMPERATURE (MINIMUM)(°C)	83
INLET WATER TEMPERATURE (°F)	180
INLET WATER TEMPERATURE (°C)	83
FLOW PRESSURE (PSI)	20 ± 5
WATER LINE SIZE (NPT)	3/4"
DRAIN LINE SIZE (NPT)	1 1/2"

SECTION 1: SPECIFICATION INFORMATION

ELECTRICAL REQUIREMENTS

NOTE: Typical Electrical Circuit is based upon (1) 125% of the full amperage load of the machine and (2) typical fixed-trip circuit breaker sizes as listed in the NEC 2002 Edition. Local codes may require more stringent protection than what is displayed here. Always verify with your electrical service contractor that your circuit protection is adequate and meets all applicable national and local codes. These numbers are provided in this manual simply for reference and may change without notice at any given time.

TEMPSTAR/TEMPSTAR SDS:

<u>VOLTS</u>	<u>PH</u>	<u>HZ</u>	<u>RINSE HEATER RATINGS</u>	<u>TOTAL AMPS</u>	<u>TYPICAL ELECTRICAL CIRCUIT</u>
208	1	50	12KW@240V	71 A	90 AMP
208	1	50	14KW@240V	78 A	100 AMP
230	1	50	12KW@240V	78 A	100 AMP
230	1	50	14KW@240V	86 A	110 AMP
208	3	50	12KW@240V	45 A	60 AMP
208	3	50	14KW@240V	49 A	70 AMP
230	3	50	12KW@240V	48 A	60 AMP
230	3	50	14KW@240V	53 A	70 AMP
380	3	50	12KW@380V	29 A	40 AMP
380*	3	50	14KW@208V	34 A	45 AMP
415	3	50	12KW@415V	26 A	35 AMP
415	3	50	14KW@415V	29 A	40 AMP
440	3	50	12KW@460V	21 A	30 AMP
440	3	50	14KW@460V	25 A	35 AMP
208	1	60	12KW@240V	69 A	90 AMP
208	1	60	14KW@240V	76 A	100 AMP
230	1	60	12KW@240V	76 A	100AMP
230	1	60	14KW@240V	84 A	110 AMP
208	3	60	12KW@240V	43 A	60 AMP
208	3	60	14KW@240V	47 A	60 AMP
230	3	60	12KW@240V	46 A	60 AMP
230	3	60	14KW@240V	51 A	70 AMP
460	3	60	12KW@480V	22 A	30 AMP
460	3	60	14KW@480V	25 A	35 AMP

TEMPSTAR LT/TEMPSTAR NB:

<u>VOLTS</u>	<u>PH</u>	<u>HZ</u>	<u>RINSE HEATER RATINGS</u>	<u>TOTAL AMPS</u>	<u>TYPICAL ELECTRICAL CIRCUIT</u>
208	1	50	N/A	28 A	35 AMP
230	1	50	N/A	30 A	40 AMP
208	3	50	N/A	20 A	25 AMP
230	3	50	N/A	21 A	30 AMP
380	3	50	N/A	10 A	15 AMP
415	3	50	N/A	10 A	15 AMP
440	3	50	N/A	8 A	15 AMP
208	1	60	N/A	26 A	35 AMP
230	1	60	N/A	28 A	35 AMP
208	3	60	N/A	18 A	25 AMP
230	3	60	N/A	28 A	35 AMP
460	3	60	N/A	8 A	15 AMP

TEMPSTAR S:

<u>VOLTS</u>	<u>PH</u>	<u>HZ</u>	<u>RINSE HEATER RATINGS</u>	<u>TOTAL AMPS</u>	<u>TYPICAL ELECTRICAL CIRCUIT</u>
208	1	60	N/A	6 A	15 AMP
230	1	60	N/A	6 A	15 AMP
208	3	60	N/A	6 A	15 AMP
230	3	60	N/A	6 A	15 AMP

* This model is wired in a wye configuration for the heaters.

SECTION 1: SPECIFICATION INFORMATION
DIMENSIONS TEMPSTAR/TEMPSTAR LT/NB (SIDE MOUNTED CONTROL BOX)

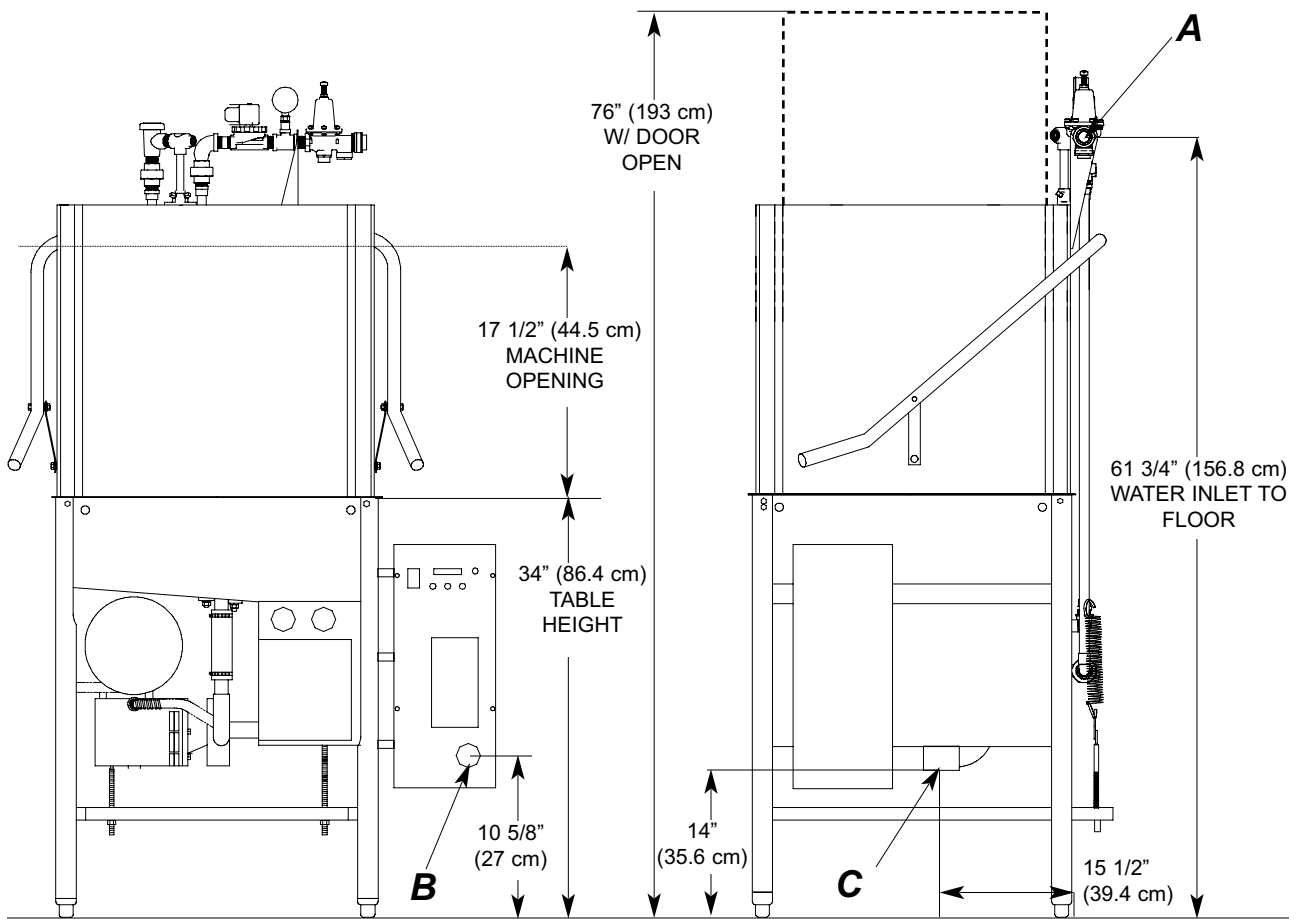
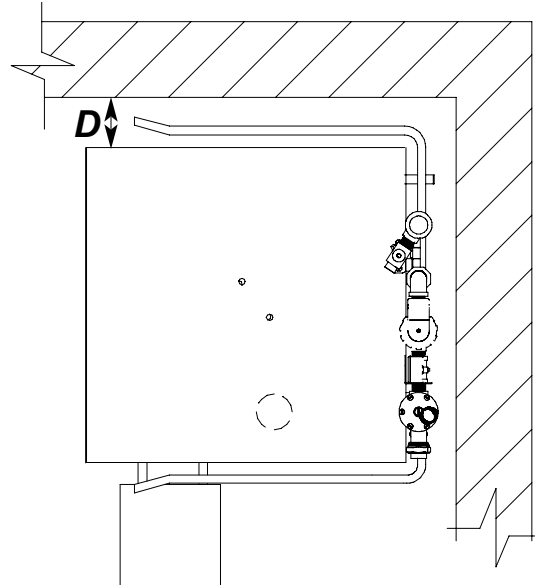
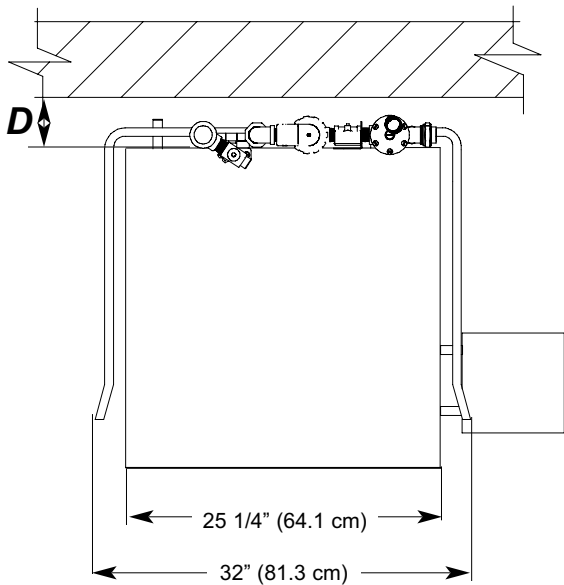

LEGEND:

A- WATER INLET (3/4" NPT)
B- ELECTRICAL CONNECTION POINT

C- DRAIN (1 1/2" NPT)
D- STANDARD CLEARANCE BETWEEN MACHINE AND WALL (WITH DISHTABLE) IS 4" (10.2 cm).

SECTION 1: SPECIFICATION INFORMATION

DIMENSIONS TEMPSTAR/NB/LT/S (TOP MOUNTED CONTROL BOX)

A- WATER INLET (3/4" NPT)
B- ELECTRICAL CONNECTION POINT
C- DRAIN (1 1/2" NPT)

LEGEND

D- STANDARD CLEARANCE BETWEEN MACHINE AND WALL (WITH DISHTABLE) IS 4" (10.2 cm).

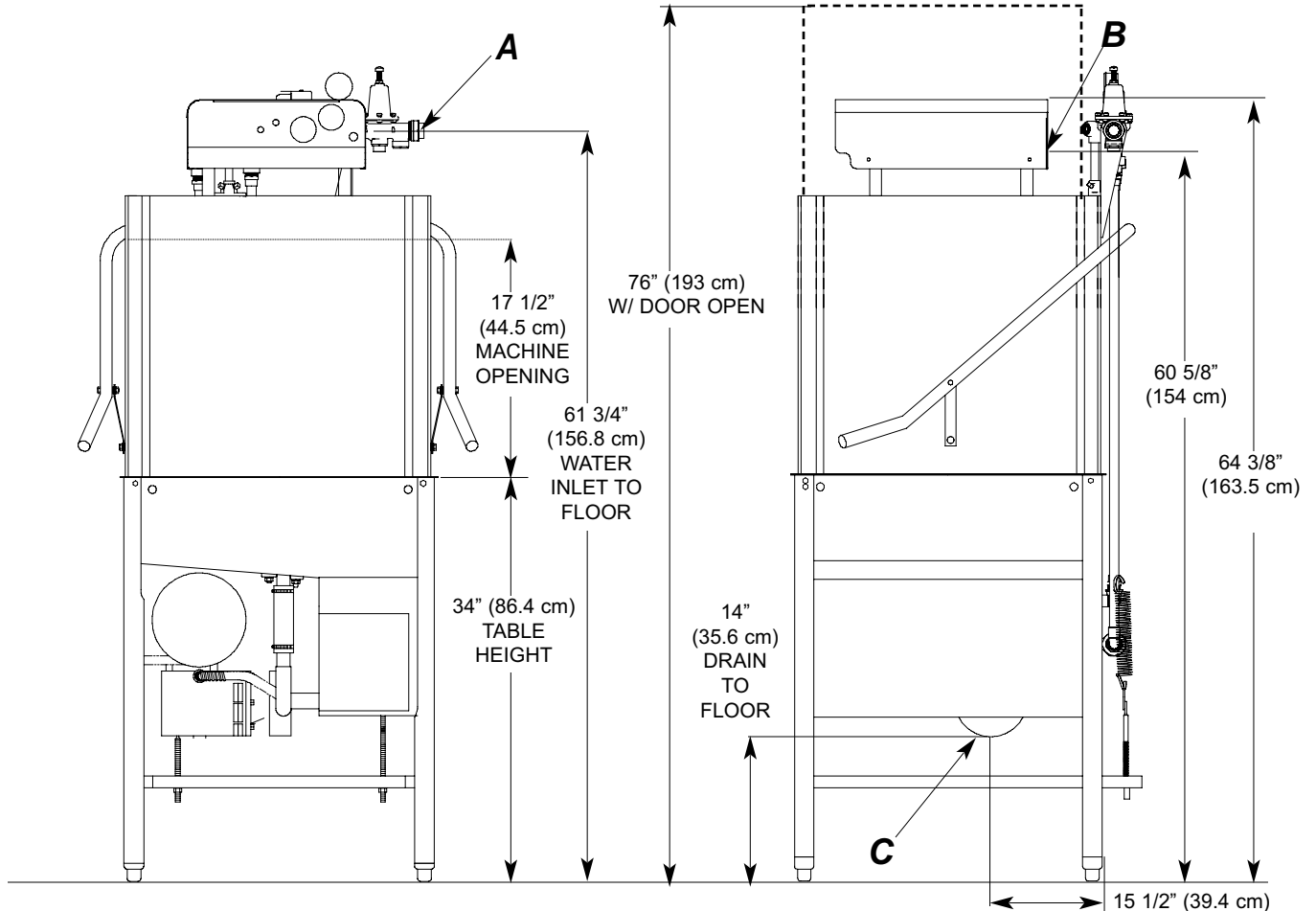
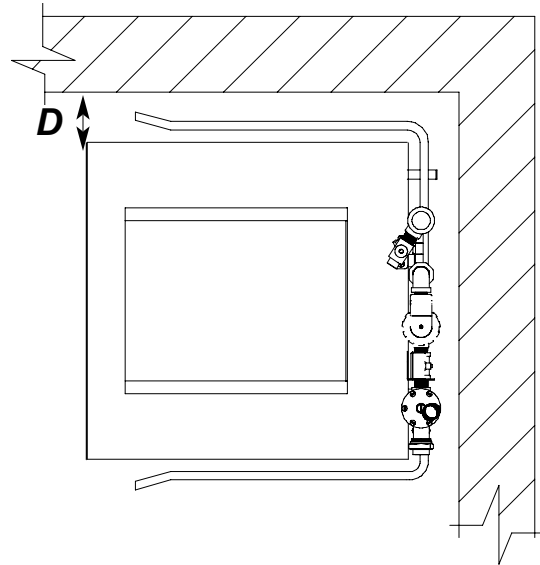
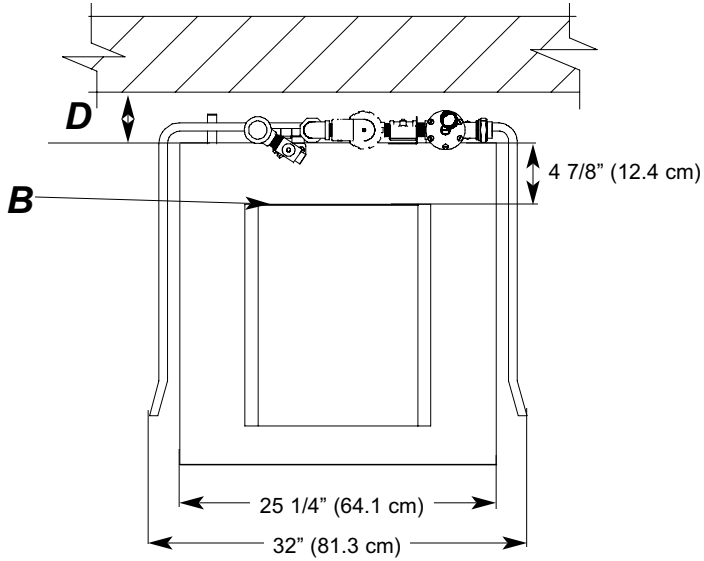

SECTION 1: SPECIFICATION INFORMATION

DIMENSIONS TEMPSTAR SDS

- A- WATER INLET (3/4" NPT)
- B- ELECTRICAL CONNECTION POINT
- C- DRAIN (1 1/2" NPT)

- D- STANDARD CLEARANCE BETWEEN MACHINE AND WALL (WITH DISHTABLE) IS 4" (10.2 cm).
- E- CHEMICAL DISPENSING SYSTEM

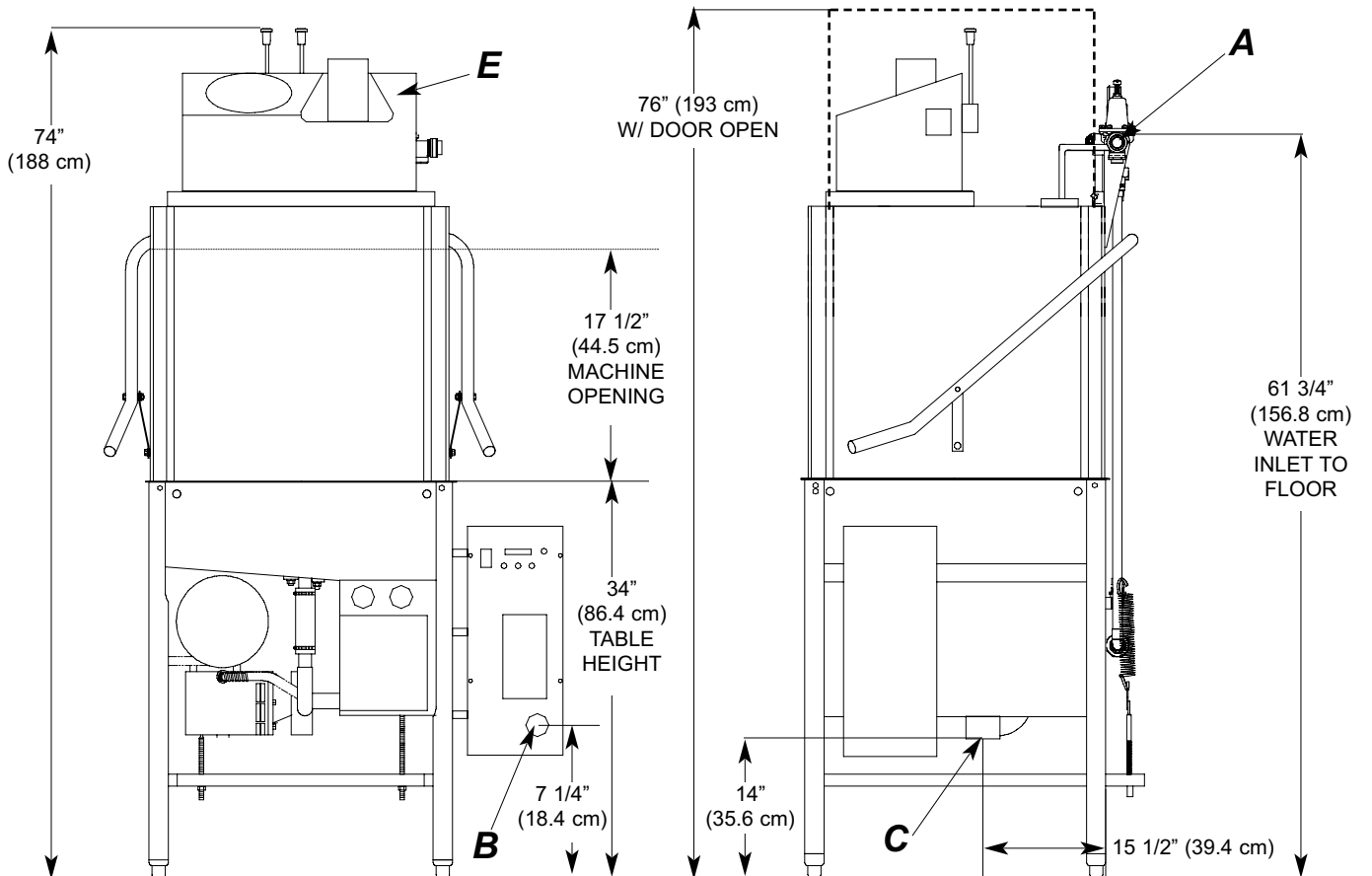
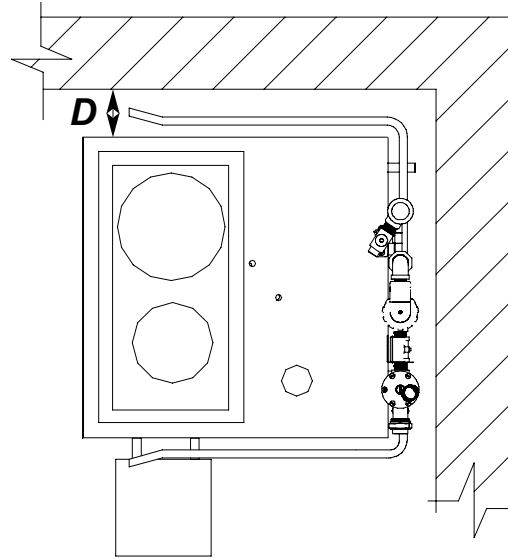
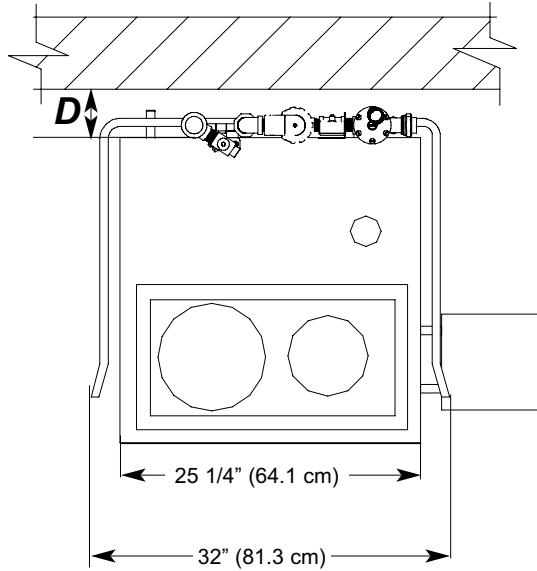

SECTION 1: SPECIFICATION INFORMATION

TABLE DIMENSIONS

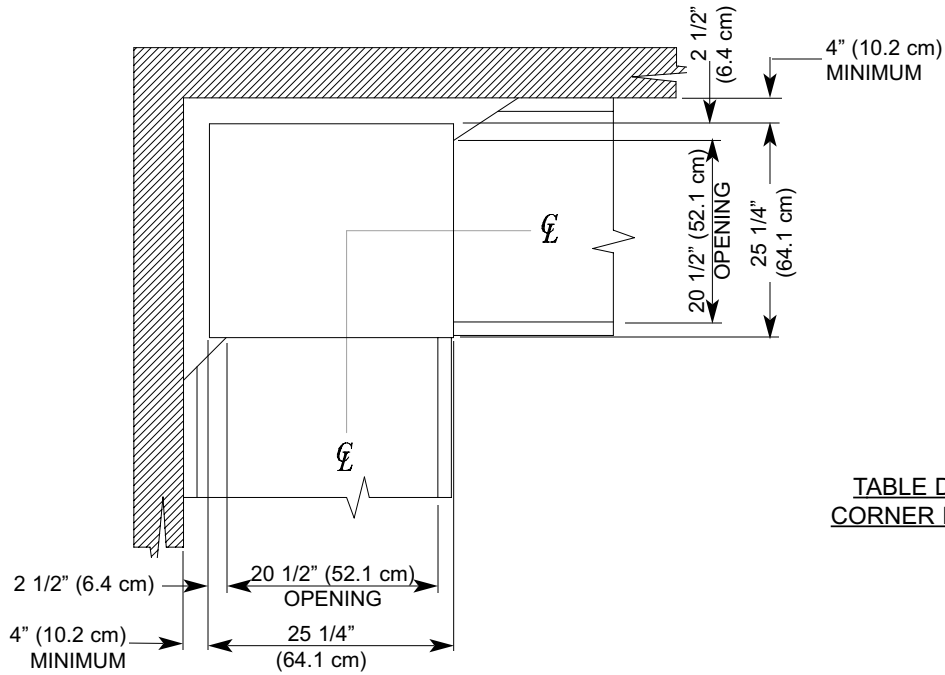

**TABLE DIMENSIONS
CORNER INSTALLATION**

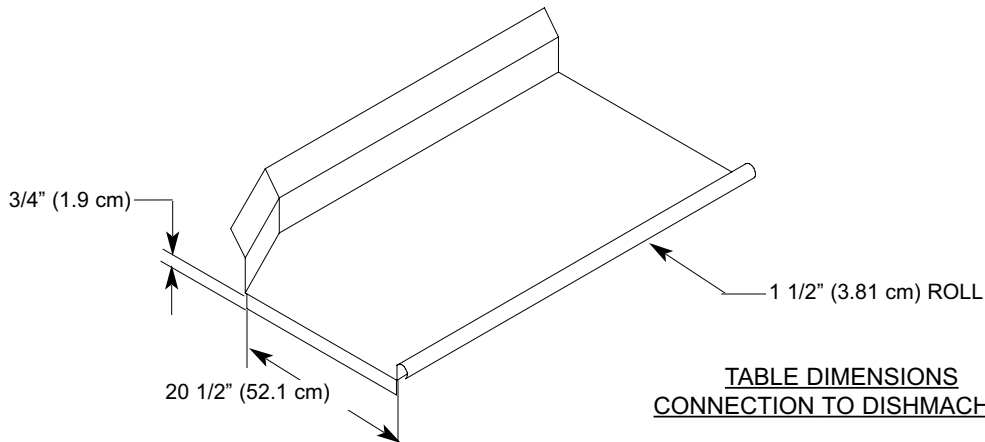

**TABLE DIMENSIONS
CONNECTION TO DISHWASHER**

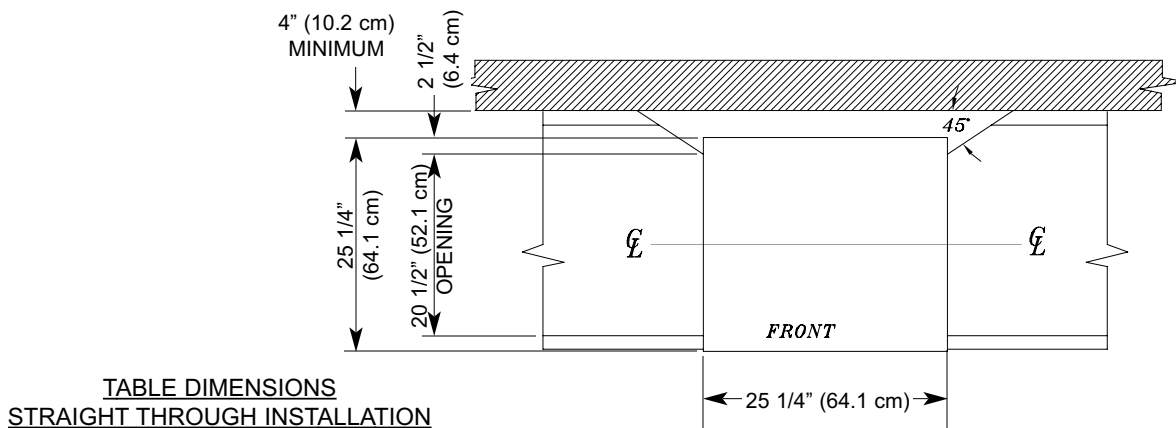

**TABLE DIMENSIONS
STRAIGHT THROUGH INSTALLATION**

**SECTION 2:
INSTALLATION/OPERATION
INSTRUCTIONS**

SECTION 2: INSTALLATION/OPERATION INSTRUCTIONS

INSTALLATION INSTRUCTIONS

VISUAL INSPECTION: Before installing the unit, check the container and machine for damage. A damaged container is an indicator that there may be some damage to the machine. If there is damage to both the container and machine, do not throw away the container. The dishmachine has been inspected and packed at the factory and is expected to arrive to you in new, undamaged condition. However, rough handling by carriers or others may result in there being damage to the unit while in transit. If such a situation occurs, do not return the unit to Jackson; instead, contact the carrier and ask them to send a representative to the site to inspect the damage to the unit and to complete an inspection report. You must contact the carrier within 48 hours of receiving the machine. Also, contact the dealer through which you purchased the unit.

UNPACKING THE DISHMACHINE: Once the machine has been removed from the container, ensure that there are no missing parts from the machine. This may not be obvious at first. If it is discovered that an item is missing, contact Jackson immediately to have the missing item shipped to you.

LEVEL THE DISHMACHINE: The dishmachine is designed to operate while being level. This is important to prevent any damage to the machine during operation and to ensure the best results when washing ware. The unit comes with adjustable bullet feet, which can be turned using a pair of channel locks or by hand if the unit can be raised safely. Ensure that the unit is level from side to side and from front to back before making any connections.

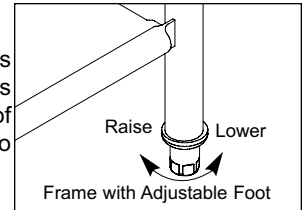

PLUMBING THE DISHMACHINE: All plumbing connections must comply with all applicable local, state, and national plumbing codes. The plumber is responsible for ensuring that the incoming water line is thoroughly flushed prior to connecting it to any component of the dishmachine. It is necessary to remove all foreign debris from the water line that may potentially get trapped in the valves or cause an obstruction. Any valves that are fouled as a result of foreign matter left in the water line, and any expenses resulting from this fouling, are not the responsibility of the manufacturer.

CONNECTING THE DRAIN LINE: The drain for the Tempstar models covered in this manual are gravity discharge drains. All piping from the 1 1/2" FNPT connection on the wash tank must be pitched (1/4" per foot) to the floor or sink drain. All piping from the machine to the drain must be a minimum 1 1/2" I.P.S. and shall not be reduced. There must also be an air gap between the machine drain line and the floor sink or drain. If a grease trap is required by code, it should have a flow capacity of 5 gallons per minute.

WATER SUPPLY CONNECTION: Ensure that you have read the section entitled "PLUMBING THE DISHMACHINE" above before proceeding. Install the water supply line (3/4" pipe size minimum) to the dishmachine line strainer using copper pipe. It is recommended that a water shut-off valve be installed in the water line between the main supply and the machine to allow access for service.

The water supply line is to be capable of 20 ±5 PSI "flow" pressure at the recommended temperature indicated on the data plate.

In areas where the water pressure fluctuates or is greater than the recommended pressure, it is suggested that a water pressure regulator be installed. The Tempstar models covered in this manual come with water pressure regulators as standard equipment. Please notify Jackson immediately if this component is not present on your machine.

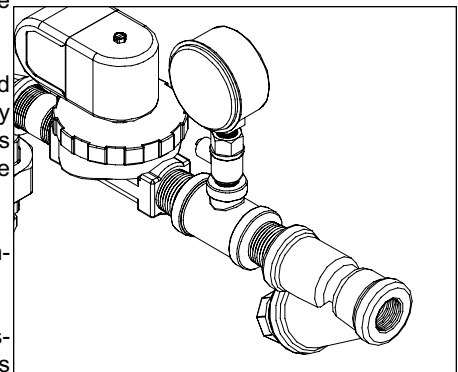

Incoming Plumbing Y-strainer Connection

Do not confuse static pressure with flow pressure. Static pressure is the line pressure in a "no flow" condition (all valves and services are closed). Flow pressure is the pressure in the fill line when the fill valve is opened during the cycle.

It is also recommended that a shock absorber (not supplied with the Tempstar model) be installed in the incoming water line. This prevents line hammer (hydraulic shock), induced by the solenoid valve as it operates, from causing damage to the equipment.

STEAM LINE CONNECTION: The steam machines come with lines by which the source steam needs to be connected. Connect all steam lines to the machine as all applicable codes provide. See machine data plate for information concerning steam flow pressure.

CHEMICAL DISPENSING EQUIPMENT: The Tempstar LT machine requires that a separate chemical feeder be connected to it to provide the required detergent and sanitizer. This feeder needs to be able to operate against a head of 25 PSI and provide 1.79 ml of a 10% Chlorine sanitizer per minute.

SECTION 2: INSTALLATION/OPERATION INSTRUCTIONS

INSTALLATION INSTRUCTIONS (CONTINUED)

PLUMBING CHECK: Slowly turn on the water supply to the machine after the incoming fill line and the drain line have been installed. Check for any leaks and repair as required. All leaks must be repaired prior to placing the machine in operation.

ELECTRICAL POWER CONNECTION: Electrical and grounding connections must comply with the applicable portions of the National Electrical Code ANSI/NFPA 70 (latest edition) and/or other electrical codes.

Disconnect electrical power supply and place a tag at the disconnect switch to indicate that you are working on the circuit.

The dishmachine data plate is located on the right side and to the front of the machine. Refer to the data plate for machine operating requirements, machine voltage, total amperage load and serial number.

To install the incoming power lines, open the control box. This will require taking a phillipshead screwdriver and removing the four (4) screws on the front cover of the control box. Install 3/4" conduit into the pre-punched holes in the back of the control box. Route power wires and connect to power block and grounding lug. Install the service wires (L1, L2, and L3 (3 phase only)) to the appropriate terminals as they are marked on the terminal block. Install the grounding wire into the lug provided. Tighten the connections. It is recommended that "DE-OX" or another similar anti-oxidation agent be used on all power connections.

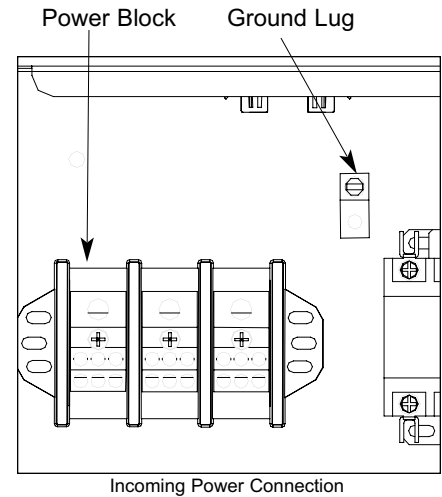

VOLTAGE CHECK: Ensure that the power switch is in the OFF position and apply power to the dishmachine. Check the incoming power at the terminal block and ensure it corresponds to the voltage listed on the data plate. If not, contact a qualified service agency to examine the problem. Do not run the dishmachine if the voltage is too high or too low. Shut off the service breaker and mark it as being for the dishmachine. Advise all proper personnel of any problems and of the location of the service breaker. Replace the control box cover and tighten down the screws.

SECTION 2: INSTALLATION/OPERATION INSTRUCTIONS

OPERATION INSTRUCTIONS

PREPARATION: Before proceeding with the start-up of the unit, verify the following:

1. The pan strainer and pump suction strainer are in place and are clean.
2. The overflow tube and o-ring are installed.
3. That the wash and rinse arms are screwed securely into place and that their endcaps are tight. The wash and rinse arms should rotate freely.

POWER UP: To energize the unit, turn on the power at the service breaker. The voltage should have been previously verified as being correct. If not, the voltage will have to be verified.

FILLING THE WASH TUB: Ensure that the delime switch is in the NORMAL position, and place the power switch into the ON position. The Tempstar should fill automatically and shut off when the appropriate level is reached (just below the pan strainer). Verify that the drain stopper is preventing the wash tub water from leaking excessively. There may be some slight leakage from the drain hole. Verify that there are no other leaks on the unit before proceeding any further. The wash tub must be completely filled before operating the wash pump to prevent damage to the component. Once the wash tub is filled, the unit is ready for operation.

WARE PREPARATION: Proper preparation of ware will help ensure good results and less re-washes. If not done properly, ware may not come out clean and the efficiency of the dishmachine will be reduced. It is important to remember that a dishmachine is not a garbage disposal and that simply throwing unscrapped dishes into the machine simply defeats the purpose altogether of washing the ware. Scraps should be removed from ware prior to being loaded into a rack. Pre-rinsing and pre-soaking are good ideas, especially for silverware and casserole dishes. Place cups and glasses upside down in racks so that they do not hold water during the cycle. The dishmachine is meant not only to clean, but to sanitize as well, to destroy all of the bacteria that could be harmful to human beings. In order to do this, ware must be properly prepared prior to being placed in the machine.

DAILY MACHINE PREPARATION: Refer to the section entitled "PREPARATION" at the top of this page and follow the instructions there. Afterwards, check that all of the chemical levels are correct and/or that there is plenty of detergent available for the expected workload.

WARM-UP CYCLES: For a typical daily start-up, it may be necessary to run the machine through 3 cycles to ensure that all of the cold water is out of the system and to verify that the unit is operating correctly. To cycle the machine, ensure that the power is on and that the tub has filled to the correct level. Lift the doors and the cycle light will illuminate. When the light goes out, close the doors, the unit will start, run through the cycle, and shut off automatically. Repeat this two more times. The unit should now be ready to proceed with the washing of ware.

WASHING A RACK OF WARE: To wash a rack, open the doors completely (being careful for hot water that may drip from the doors) and slide the rack into the unit.

Close the doors and the unit will start automatically. Once the cycle is completed, open the door (again watching for the dripping hot water) and remove the rack of clean ware. Replace with a rack of soiled ware and close the doors. The process will then repeat itself.

OPERATIONAL INSPECTION: Based upon usage, the pan strainer may become clogged with soil and debris as the workday progresses. Operators should regularly inspect the pan strainer to ensure it has not become clogged. If the strainer does, it will reduce the washing capability of the machine. Instruct operators to clean out the pan strainer at regular intervals or as required by work load.

SHUTDOWN AND CLEANING: At the end of the workday, close the doors. When the unit completes the cycle, turn the power switch to the OFF position and open the doors. Remove and clean the pan strainer. Remove the drain stopper from the tub and allow the tub to drain (NOTE: the wash tank water will be hot so caution is advised). Once the wash tub is drained, remove the pump suction strainer. Remove soil and debris from the strainer and set to the side. Unscrew the wash and rinse arms from their manifolds. Remove the endcaps and flush the arms with water. Use a brush to clean out the inside of the arms. If the nozzles appear to be clogged, use a toothpick to remove the obstruction. Wipe the inside of the unit out, removing all soil and scraps. Reassembly the wash and rinse arms and replace them in the unit. The arms only need to be hand tight, do not use tools to tighten them down. Reinstall the drain stopper and strainers and close the doors.

SECTION 2: INSTALLATION/OPERATION INSTRUCTIONS

DETERGENT CONTROL

Detergent usage and water hardness are two factors that contribute greatly to how efficiently your dishmachine will operate. Using detergent in the proper amount can become, in time, a source of substantial savings. A qualified water treatment specialist can tell you what is needed for maximum efficiency from your detergent, but you should still know some basics so you'll understand what they are talking about.

First, you must understand that hard water greatly effects the performance of the dishmachine. Water hardness is the amount of dissolved calcium and magnesium in the water supply. The more dissolved solids in the water, the greater the water hardness. Hard water works against detergent, thereby causing the amount of detergent required for washing to increase. As you use more detergent, your costs for operating the dishmachine will increase and the results will decrease. The solids in hard water also may build-up as a scale on wash and rinse heaters, decreasing their ability to heat water. Water temperature is important in removing soil and sanitizing dishes. If the water cannot get hot enough, your results may not be satisfactory. This is why Jackson recommends that if you have installed the machine in an area with hard water, that you also install some type of water treatment equipment to help remove the dissolved solids from the water before it gets to the dishmachine.

Second, hard water may have you adding drying agents to your operating cycle to prevent spotting, when the real problem is deposited solids on your ware. As the water evaporates off of the ware, the solids will be left behind to form the spotting and no amount of drying agent will prevent this. Again, using treated water will undoubtedly reduce the occurrences of this problem.

Third, treated water may not be suitable for use in other areas of your operation. For instance, coffee made with soft water may have an acid or bitter flavor. It may only be feasible to install a small treatment unit for the water going into the dishmachine itself. Discuss this option with your qualified water treatment specialist.

Even after the water hardness problems have been solved, there still must be proper training of dishmachine operators in how much detergent is to be used per cycle. Talk with your water treatment specialist and detergent vendor and come up with a complete training program for operators. Using too much detergent has as detrimental effects as using too little. The proper amount of detergent must be used for job. It is important to remember that certain menu items may require extra detergent by their nature and personnel need to be made aware of this. Experience in using the dishmachine under a variety of conditions, along with good training in the operation of the machine, can go a long way in ensuring your dishmachine operates as efficiently as possible.

Certain dishmachine models require that chemicals be provided for proper operation and sanitization. Some models even require the installation of third-party chemical feeders to introduce those chemicals to the machine. Jackson does not recommend or endorse any brand name of chemicals or chemical dispensing equipment. Contact your local chemical distributor for questions concerning these subjects.

Some dishmachines come equipped with integral solid detergent dispensers. These dispensers are designed to accommodate detergents in a certain sized container. If you have such a unit, remember to explain this to your chemical distributor upon first contacting them.

As explained before, water temperature is an important factor in ensuring that your dishmachine functions properly. The data plate located on each unit details what the minimum temperatures must be for either the incoming water supply, the wash tank and the rinse tank, depending on what model of dishmachine you have installed. These temperatures may also be followed by temperatures that Jackson recommends to ensure the highest performance from you dishmachine. However, if the minimum requirements are not met, the chances are your dishes will not be clean or sanitized. Remember, a dish can look clean, but it may not be sanitized. Instruct your dishmachine operators to observe the required temperatures and to report when they fall below the minimum allowed. A loss of temperature can indicate a much larger problem such as a failed heater or it could also indicate that the hot water heater for your operation is not up to capacity and a larger one may need to be installed.

There are several factors to consider when installing your dishmachine to ensure that you get the best possible results from it and that it operates at peak efficiency for many years. Discuss your concerns with your local chemical distributor and water treatment specialist before there is a problem.

SECTION 2: INSTALLATION/OPERATION INSTRUCTIONS

FALSE PANEL INSTALLATION

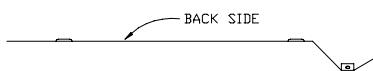
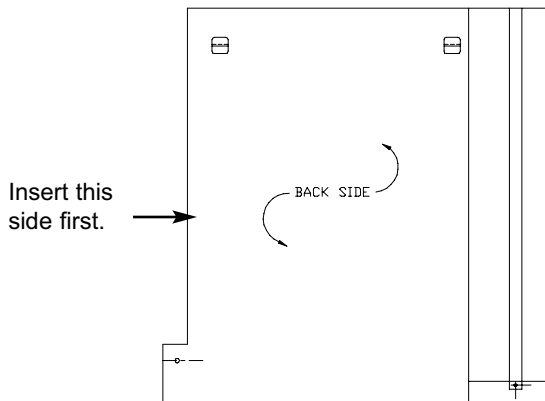
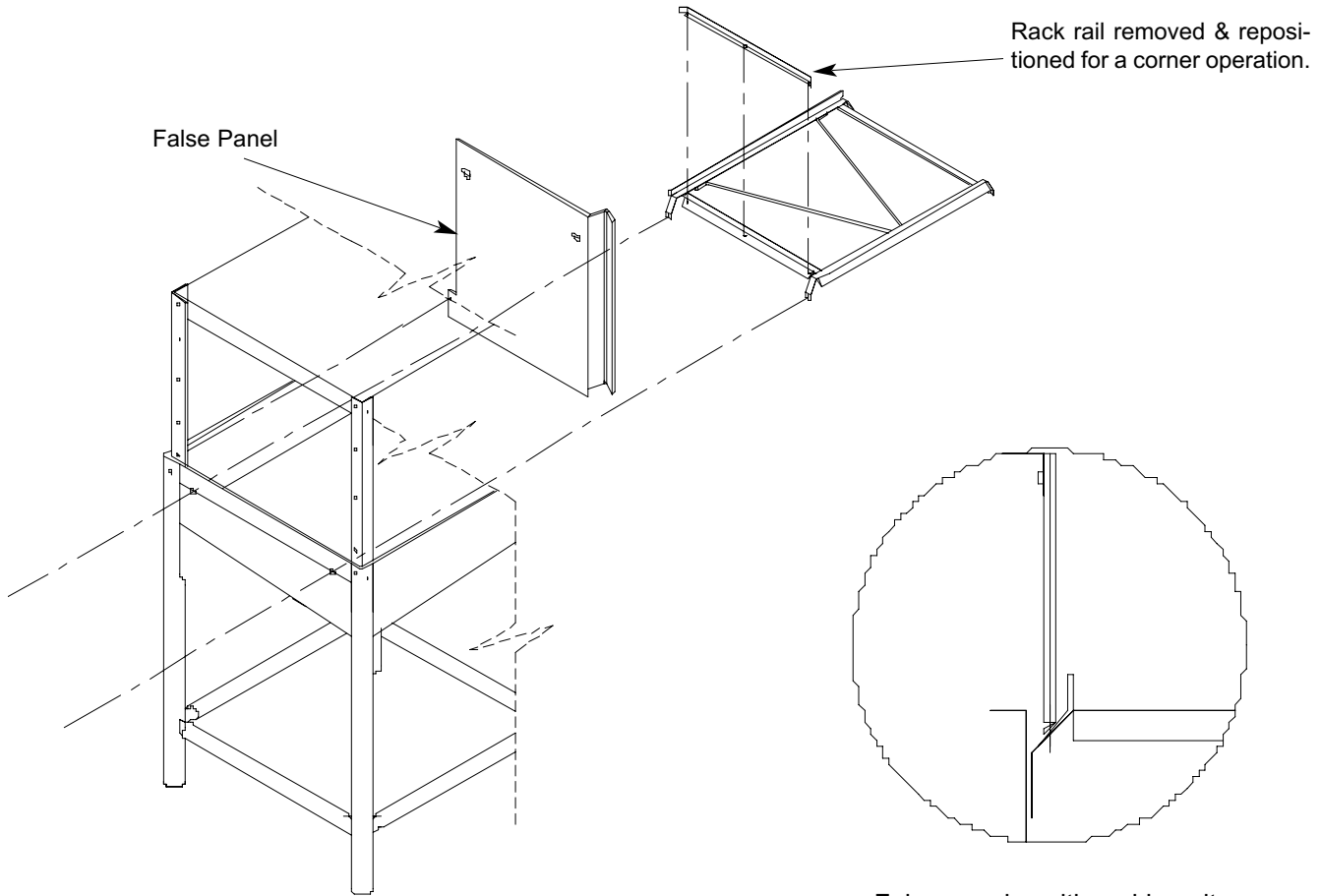

Bottom of side panel.

1. Remove the rack assembly from the unit.
2. False panel will mount inside the dishmachine.
3. Position panel in unit on side to be closed.
4. Hold panel against side of dishmachine and push up.
5. Panel will clip in at the top, inside unit.
6. Holes in false panel will line up with rack assembly holes.
7. Re-install screws for rack assembly which will secure false panel to unit.
8. Re-assemble the rack track in an "L" shape for a corner operation.

SECTION 3: PREVENTATIVE MAINTENANCE

SECTION 3: PREVENTATIVE MAINTENANCE

PREVENTATIVE MAINTENANCE

The dishmachines covered in this manual are designed to operate with a minimum of interaction with the operator. However, this does not mean that some items will not wear out in time. Jackson highly recommends that any maintenance and repairs not specifically discussed in this manual should be performed by **QUALIFIED SERVICE PERSONNEL ONLY**. Performing maintenance on your dishmachine may void your warranty if it is still in effect, so if you have a question or concern, do not hesitate to contact one of the **QUALIFIED SERVICE AGENCIES** listed in the back of this manual.

There are many things that operators can do to prevent catastrophic damage to the dishmachine. One of the major causes of component failure has to do with prescraping procedures. A dishmachine is not a garbage disposal; any large pieces of material that are put into the machine shall remain in the machine until they are either broken up (after spreading out on your ware!) or physically removed. Strainers are installed to help catch debris, but they do no good if they are clogged. Have operators regularly inspect the pan strainers to ensure (1) that they are free of soil and debris and (2) they are laying flat in the tub.

When cleaning out strainers, do **NOT** beat them on waste cans. The strainers are made of metal and can be forgiving; but once severe damage is done, it is next to impossible for the strainer to work in the way it was designed to. Wipe out strainers with a rag and rinse under a faucet if necessary. For stubborn debris, a toothpick should be able to dislodge any obstructions from the perforations. Always ensure that strainers are placed back in the machine before operation and that they lay flat in the tub.

You may wish to learn more about how your water hardness will effect the performance of your machine. Hard water makes dishmachines work harder and decreases efficiency.

Again, it is important to remind operators that trying to perform corrective maintenance on the dishmachine could lead to larger problems or even cause harm to the operator. If a problem is discovered; secure the dishmachine using proper shut down procedures as listed in this manual and contact a **QUALIFIED SERVICE AGENCY**.

Some problems, however, may have nothing to do with the machine itself and no amount of preventative maintenance is going to help. A common problem has to do with temperatures being too low. Verify that the water temperatures coming to your dishmachine match the requirements listed on the machine data plate. There can be a variety of reasons why your water temperature could be too low and you should discuss it with a **QUALIFIED SERVICE AGENCY** to determine what can be done.

By following the operating and cleaning instructions in this manual, you should get the most efficient results from your machine. As a reminder, here are some steps to take to ensure that you are using the dishmachine the way it was designed to work:

1. Ensure that the water temperatures match those listed on the machine data plate.
2. Ensure that all strainers are in place before operating the machine.
3. Ensure that all wash and/or rinse arms are secure in the machine before operating.
4. Ensure that drains are closed/sealed before operating.
5. Remove as much soil from dishes by hand as possible before loading into racks.
6. Do not overfill racks.
7. Ensure that glasses are placed upside down in the rack.
8. Ensure that all chemicals being injected to machine have been verified as being at the correct concentrations.
9. Clean out the machine at the end of every workday as per the instructions in the manual.
10. Always contact a **QUALIFIED SERVICE AGENCY** whenever a serious problem arises.
11. Follow all safety procedures, whether listed in this manual or put forth by local, state or national codes/regulations.

SECTION 4: TROUBLESHOOTING SECTION

SECTION 4: TROUBLESHOOTING

COMMON PROBLEMS



WARNING: Inspection, testing and repair of electrical equipment should only be performed by a qualified service technician. Many of the tests require that the unit have power to it and live electrical components be exposed. USE EXTREME CAUTION WHEN TESTING THE MACHINE.

Problem: Dishmachine will not fill after the door is close. Power “ON” light is illuminated.

1. Faulty rinse solenoid valve. Repair or replace valve as required.
2. Faulty door switch. Verify the wiring of the switch; if correct, replace the switch.
3. Fouled/faulty high level probe. Clean probe if fouled. If clean, and still not working, replace.

Problem: Dishmachine will not fill after the door is closed. Power “ON” light is not illuminated.

1. Service breaker tripped. Reset. If the breaker trips again, contact an electrician to verify the amp draw of the machine.
2. Machine not connected to power source. Verify that the machine has been properly connected to the power source.
3. Faulty power source. Verify the wiring of the switch; if correct, replace switch.

Problem: Dishmachine will not run after the door is closed. Power “ON” light is illuminated and the unit is filling.

1. Timer motor is faulty. Verify that the timer is rotating. If not, check to see that the motor is receiving power. If so, replace the motor and/or timer assembly.
2. Wash motor faulty/damaged. Verify that the wash motor is getting power. If so, replace the motor.
3. Wash motor contactor faulty. Check for continuity; if contacts are open, replace the contactor.

Problem: Dishmachine runs continuously in the wash cycle.

1. Machine is in Delime mode. Flip NORMAL/DELIME switch to NORMAL mode.
2. Timer motor is faulty. Verify that the timer is rotating. If not, check to see that the motor is receiving power. If so, replace the motor and/or timer assembly.
3. Cam timer jammed by obstruction. Remove obstruction.

Problem: Wash or rinse heater does not work.

1. Faulty heater element. Check element for continuity; if open, replace the heater.
2. Faulty heater contactor. Replace the contactor.
3. Misadjusted/faulty thermostat(s). Verify operation and setting of thermostats, replace if necessary.

Problem: Dishmachine fill slowly and/or the rinse is weak.

1. Clogged or obstructed rinse arms. Remove and clean the rinse arms.
2. Low incoming water pressure. Adjust the water pressure regulator to ensure that there is 20 ± 5 PSI flow.
3. Y-strainer is clogged. Clean out the Y-strainer.

Problem: Rinse water not reaching required temperature.

1. Faulty rinse heater. Check element for continuity; if open, replace heater.
2. Misadjusted/faulty thermostat(s). Verify operation and setting of thermostats, replace if necessary.
3. Rinse thermometer is defective. Replace thermometer.

Problem: Wash water is not reaching required temperature.

1. Faulty wash heater. Check element for continuity; if open, relace the heater.
2. Misadjusted/faulty thermostat(s). Verify operation and setting of thermostats, replace if necessary.
3. Wash thermometer is defective. Replace thermometer.

SECTION 4: TROUBLESHOOTING

COMMON PROBLEMS



WARNING: Inspection, testing and repair of electrical equipment should only be performed by a qualified service technician. Many of the tests require that the unit have power to it and live electrical components be exposed. **USE EXTREME CAUTION WHEN TESTING THE MACHINE.**

Problem: Doors will not close completely.

1. Improper spring tension. Adjust spring tension as required by loosening (not removing) spring bolt nuts and adjusting the tension. Tighten nuts back when done.
2. Obstruction in door channel. Remove the obstruction.
3. Doors are not square with frame. Adjust the frame to accommodate the doors.

Problem: Water leaks at the wash pump.

1. Wash pump seal defective. Replace the seal.
2. Petcock or pump drain (if equipped) not shut/tight. Close or tighten.
3. Loose hoses (hose clamps) on the wash pump. Tighten the hose clamps.

Problem: Will not rinse during autcycle.

1. Defective rinse solenoid. Repair or replace the rinse solenoid as required.
2. Faulty fill microswitch. Replace microswitch.
3. No water to the machine. Verify that there is water a 20 ± 5 PSI connected to the machine.

Problem: Dishes are not coming clean.

1. Machine temperatures are not up to the minimum requirements. Verify that incoming water, rinse water, and wash water match the required temperatures as listed on the machine data plate.
2. No detergent/too much detergent. Adjust detergent concentration as required for the amount of water held by the machine.
3. Solid dispenser canister is empty. Replace the canister.

SECTION 5: PARTS SECTION

SECTION 5: PARTS SECTION

TOP MOUNTED CONTROL BOX ASSEMBLY WITH UNIVERSAL TIMER

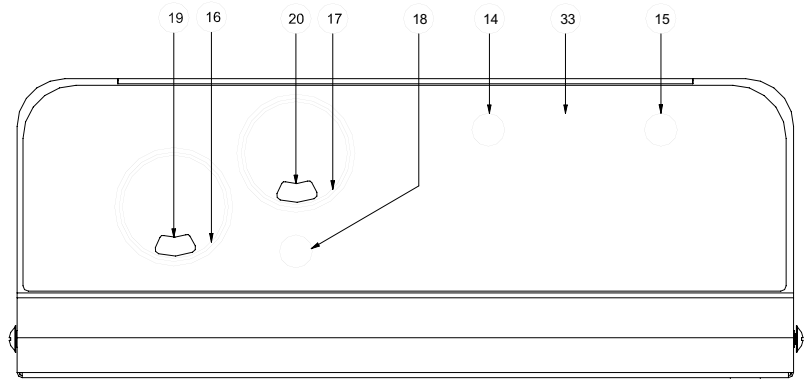
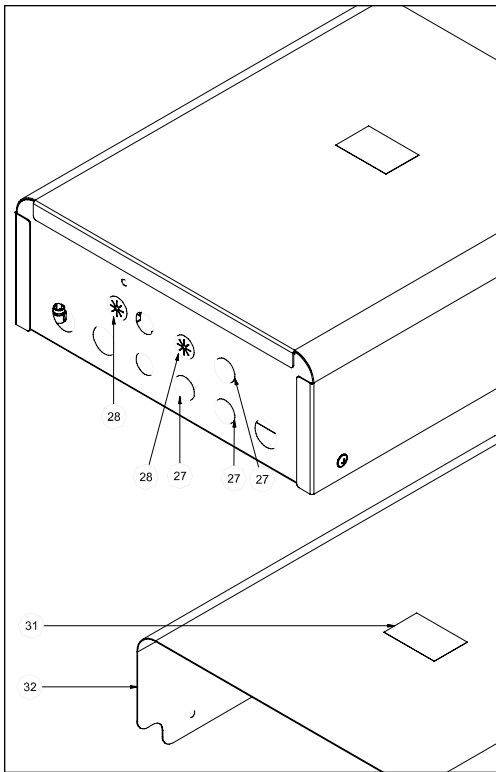
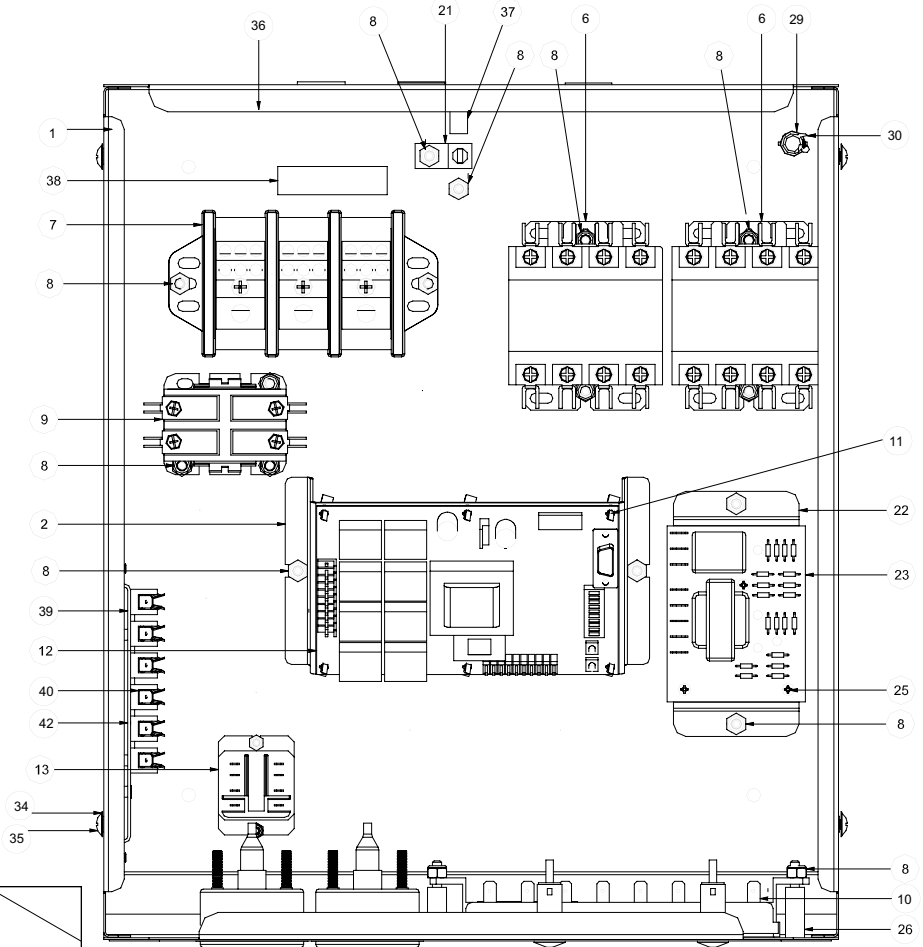

SECTION 5: PARTS SECTION

TOP MOUNTED CONTROL BOX ASSEMBLY WITH UNIVERSAL TIMER (CONTINUED)

ITEM	QTY	DESCRIPTION	Mfg. No.
1	1	Control Box Weldment	05700-003-30-14
2	1	Timer Bracket	05700-003-02-08
5	2	Locknut, 6-32 S/S Hex w/Nylon Insert	05310-373-03-00
6	2	Contactora, 4 Pole	05945-109-01-69
7	1	Terminal Block	05940-011-48-27
8	19	Locknut, 10-24 S/S Hex w/Nylon Insert	05310-373-01-00
9	1	Contactora, Wash Motor 208-230, 30Amp	05945-002-74-20
10	1	Switch, 8 Button	05930-001-99-51
11	6	Holder, Keystone	05940-002-21-87
12	1	Timer, Universal	05945-003-07-48
13	1	Relay, All Voltages	05945-111-47-51
	1	Relay, (415V, 3PH, 5 Wire Only)	05945-111-89-75
14	1	Light, Green	05945-111-44-43
15	1	Light, Red	05945-111-44-45
16	1	Temperature Gauge, Wash 96" Lead	06685-111-68-48
17	1	Temperature Gauge, Rinse 48" Lead	06685-111-68-49
18	1	Light, Yellow	05945-111-44-44
19	1	Decal Wash 150F. Deg. Min.	09905-002-97-61
20	1	Decal Wash 180F. Deg. Min.	09905-002-97-62
21	1	Ground Lug	05940-200-76-00
22	1	Bracket, Liquid Level Control Board	05700-002-13-22
23	1	Liquid Level Control Board	06680-200-08-21
24	6	Tricnut, 6-32	N/A
25	3	Screw, 6-32 x 5/8"	05305-011-39-85
26	1	Spacer, Switch Panel Temp	05700-002-50-02
27	3	Plug, 1/2"	05975-011-47-81
28	2	Grommet, 7/8" Split	05975-200-40-00
29	1	Bushing, Snap	05975-210-05-00
30	1	Clamp, Hose, .25-.312	05975-002-61-43
31	1	Decal, Warning-Disconnect Power	09905-100-75-93
32		Cover, Top Mount Control Box	05700-002-23-03
33	1	Decal, Control Box	09905-003-21-90
34	4	Lockwasher, Int. Tooth #10	05311-273-03-00
35	4	Screw, 10-32 x 3/8" Phillips Truss Head	05305-173-12-00
36	1	Decal, Copper Conductors	09905-011-47-35
37	1	Decal, Ground	09905-011-86-86
38	1	Decal, L1, L2	09905-002-78-67
39	1	Bracket, Fuse Strip	05700-002-42-03
40	1	Fuse Holder, 6 Pole	05920-002-42-13
41	2	Screw, 6-32 x 3/8" W/ Ext. Tooth Washer	05305-002-25-91
42	1	Decal, Dispenser Connection	09905-003-34-09

SECTION 5: PARTS SECTION
TOP MOUNTED CONTROL BOX ASSEMBLY (MECHANICAL TIMER)

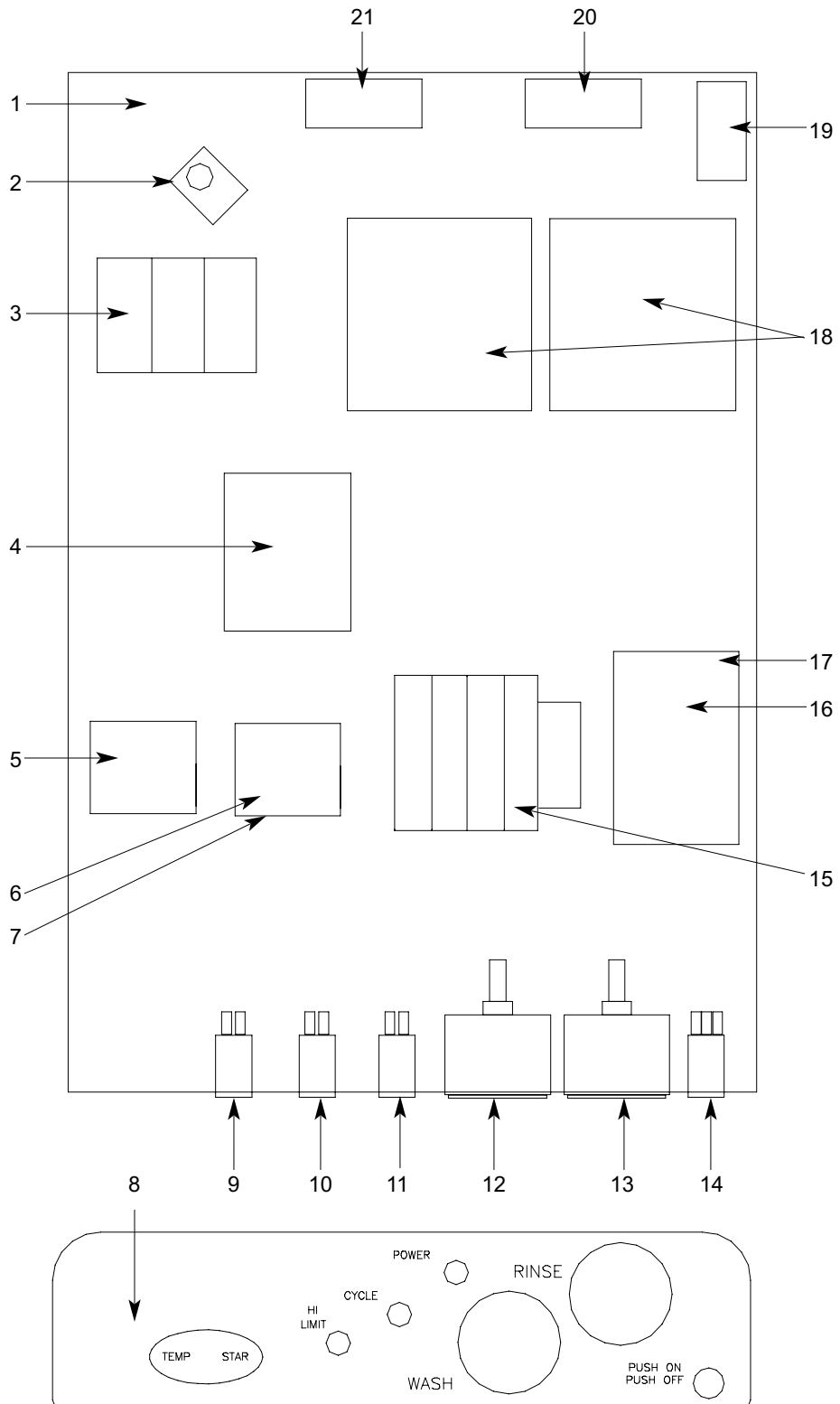

SECTION 5: PARTS SECTION

TOP MOUNTED CONTROL BOX ASSEMBLY (MECHANICAL TIMER) (CONTINUED)

ITEM	QTY	DESCRIPTION	Mfg. No.
1	1	Control Box Weldment	05700-002-29-76
2	1	Ground Lug	05940-200-76-00
3	1	Terminal Block	05940-011-48-27
3	1	Terminal Block (415V, 3PH, 5 Wire Only)	05940-002-42-24
4	1	Contact, Wash Motor 208-230	05945-002-74-20
4	1	Contact, Wash Motor (380, 415, 440, 460 Volt Units)	05945-002-65-00
4	1	Overload, 1.7-2.6 (380, 415, 440, 460 Volt Units)	05945-002-65-02
5	1	Relay, All Voltages	05945-111-47-51
5	1	Relay, (415V, 3PH, 5 Wire Only)	05945-111-89-75
6	1	Counter	05990-111-47-42
7	1	Plate, Counter Mounting	05700-002-37-71
8	1	Decal, Control Box	09905-002-31-85
9	1	Light, Yellow	05945-111-44-44
10	1	Light, Green	05945-111-44-43
11	1	Light, Red	05945-111-44-45
12	1	Temperature Gauge, Wash 96" Lead	06685-111-68-48
13	1	Temperature Gauge, Rinse 48" Lead	06685-111-68-49
14	1	Switch, Power	05930-002-29-13
15	1	Timer, 60 Hz All Voltages	05945-303-31-00
15	1	Timer, 50 Hz All Voltages	05945-306-14-00
16	1	Liquid Level Control Board	06680-200-08-21
17	1	Bracket, Liquid Level Control Board	05700-002-13-22
18	2	Heater Contactor (All Voltages) (Not used on Tempstar S)	05945-109-01-69
18	2	Heater Contactor (415V, 3PH, 5 Wire Only)	05945-002-64-96
19	1	Magnetic Reed Switch	05930-011-47-50
20	1	Normal Delime Switch	05930-301-21-18
21	1	Fuse Holder	05920-401-03-14

Other components not shown:

Cover, Top Mount Control Box	05700-002-23-03
Decal, Warning-Disconnect Power	09905-100-75-93
Screw, 10-32 x 3/8" Phillips Truss Head	05305-173-12-00
Leg, Control Box	05700-002-33-05
Screw, 1/4"-20 x 2 3/4" Hex Head Cap	05305-274-13-00
Washer, 1/4"-20 ID S/S	05311-174-01-00
Locknut, 1/4"-20 S/S Hex w/Nylon Insert	05310-374-01-00
Connector, 1/2", 90° Plastic	05975-011-45-14
Connector, 3/4", 45° Plastic	05975-011-47-74
Connector, 1/2", 45° Plastic	05975-011-45-23
Connector, 1/2", 90° Metal	05975-111-01-00
Grommet, 1/2" OD x 3/8" ID	05325-011-46-73
Grommet, 7/8" Split	05975-200-40-00
Plug, 1/2"	05975-011-47-81
Decal, Delime/Normal	09905-011-34-96
Decal, L1, L2, L3	09905-101-12-66
Decal, Copper Conductors	09905-011-47-35
Decal, Ground	09905-011-86-86

Associated Hardware:

Locknut, 6-32 S/S Hex w/Nylon Insert	05310-373-03-00
Locknut, 10-24 S/S Hex w/Nylon Insert	05310-373-01-00
Screw, 6-32 x 5/8"	05305-011-39-85
Screw, 6-32 x 3/8" Phillips Round Head	05305-171-02-00

SECTION 5: PARTS SECTION
SIDE MOUNTED CONTROL BOX ASSEMBLY

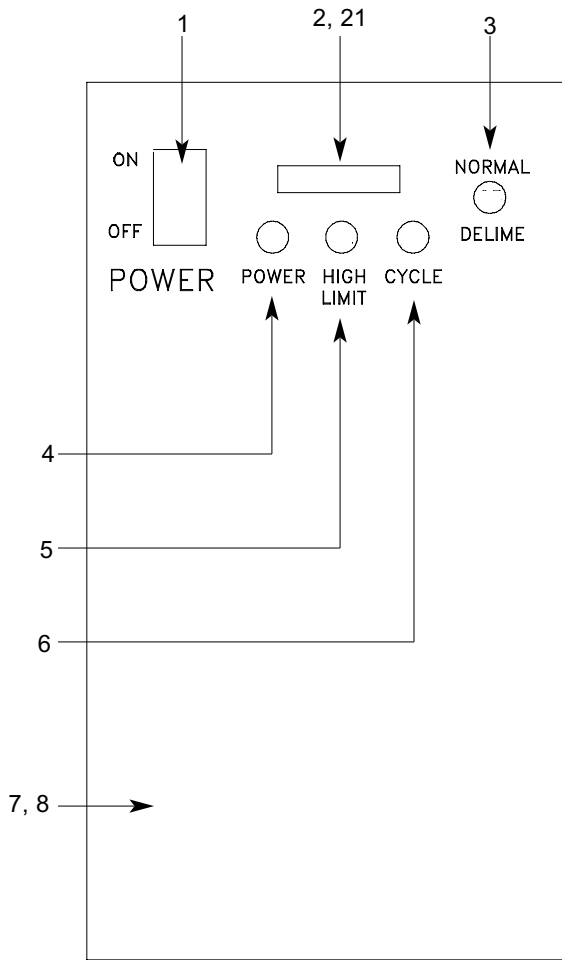

CONTROL BOX FRONT COVER

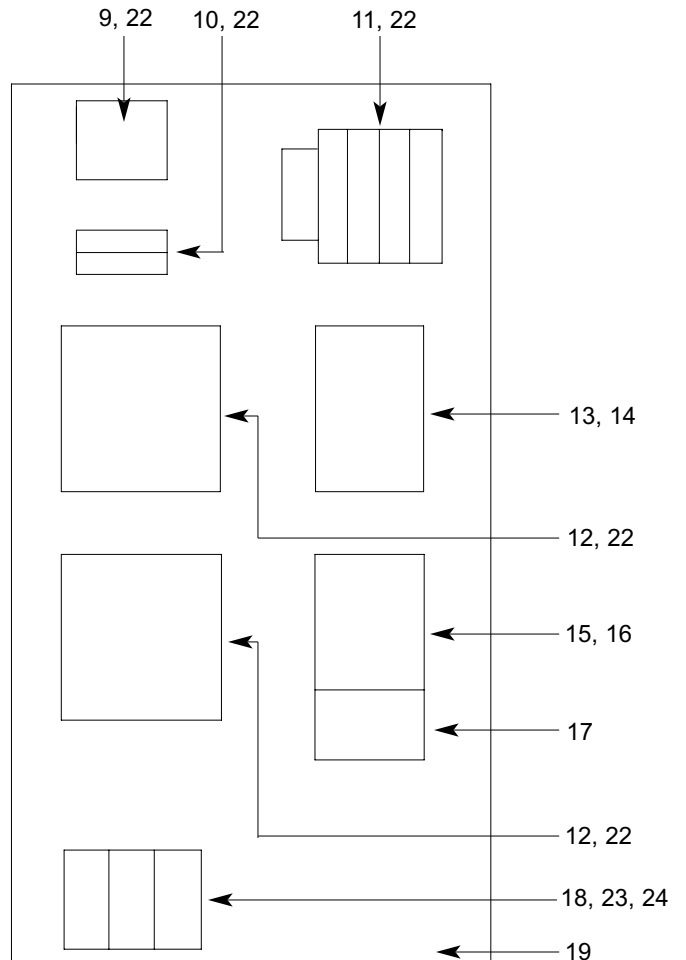

INNER CONTROL BOX LAYOUT

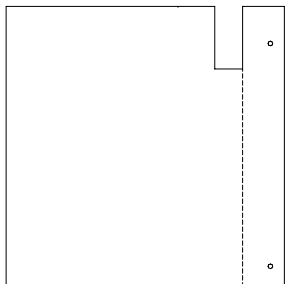

Cover, Dielectric Control Panel
 05700-021-50-89

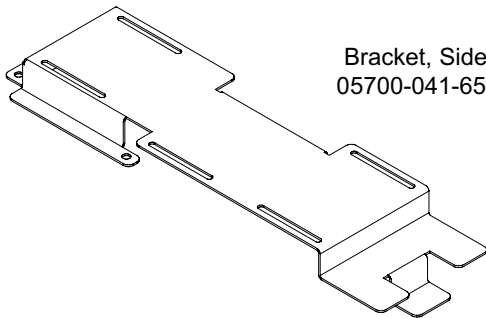

Bracket, Side Mount Electrical Box
 05700-041-65-68

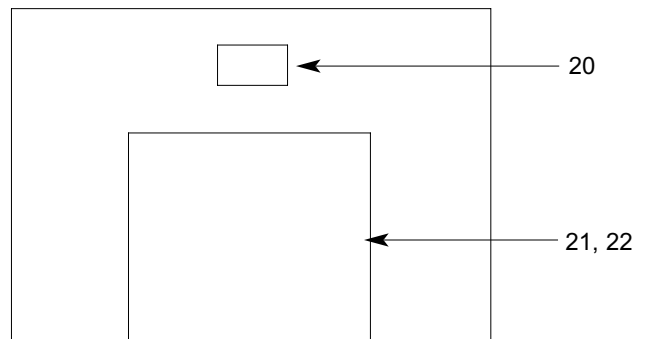

CONTROL BOX BOTTOM LAYOUT

The mounting screws for the control box front cover (10-32 X 1/2" Slotted Truss Head Screws) may be ordered using Mfg. No.: 05305-011-39-85.

SECTION 5: PARTS SECTION

SIDE MOUNTED CONTROL BOX ASSEMBLY (CONTINUED)

ITEM	QTY	DESCRIPTION	Mfg. No.
1	1	Power Switch	05930-301-21-18
2	1	Cycle Counter	05990-111-47-42
3	1	Normal/Delime Switch	05930-301-46-00
4	1	Power Light	05945-504-06-18
5	1	High Limit Light	05945-504-07-18
6	1	Cycle Light	05945-504-08-18
7	1	Decal, Control Box Cover	09905-021-64-41
8	1	Control Box Cover	05700-031-91-45
9	1	Relay, Top Mount, Control	05945-111-47-51
10	1	Fuse Holder	05920-401-03-14
11	1	Timer, 60 Hz	05945-303-31-00
11	1	Timer, 50 Hz	05945-306-14-00
12	2	Contactor, 220V, 4 Pole (1 for Tempstar NB models)	05945-109-01-69
13	1	Liquid Level Control Board	06680-200-08-21
14	2	Screw, 6-32 x 5/8" Long	05305-011-39-85
15	1	Wash Motor Contactor	05945-109-03-69
15	1	Wash Motor Contactor	05945-002-14-78
16	3	Screw, 10-32 x 3/8" Panhead	05305-173-26-00
17	1	Overload (460 Volt Unit)	05945-002-65-01
18	1	3 Pole Terminal Block	05940-011-48-27
19	1	Control Box Weldment	05700-041-47-55
20	1	Circuit Breaker, 2 AMP (460 Volt Unit)	05925-111-64-18
21	1	Transformer, (460-440 Volt Unit)	05950-111-65-93
21	1	Transformer, (380 Volt Unit)	05950-111-64-17
22	9	Screw, 6-32 x 3/8" Long	05305-171-02-00
23	3	Locknut, 10-24 w/Nylon Insert	05310-373-01-00
24	1	Ground Lug	05940-200-76-00
Other components not shown:			
		Connector, 1/2", 90° Plastic	05975-011-45-14
		Connector, 3/4", 45° Plastic	05975-011-47-74
		Connector, 1/2", 45° Plastic	05975-011-45-23
		Connector, 1/2", 90° Metal	05975-111-01-00
		Grommet, 1/2" OD x 3/8" ID	05325-011-46-73
		Grommet, 7/8" Split	05975-200-40-00
		Plug	05975-011-47-81
		Decal, Delime/Normal	09905-011-34-96
		Decal, L1, L2, L3	09905-101-12-66
		Decal, Copper Conductors	09905-011-47-35
		Decal, Ground	09905-011-86-86

SECTION 5: PARTS SECTION

SDS SIDE MOUNTED CONTROL BOX ASSEMBLY

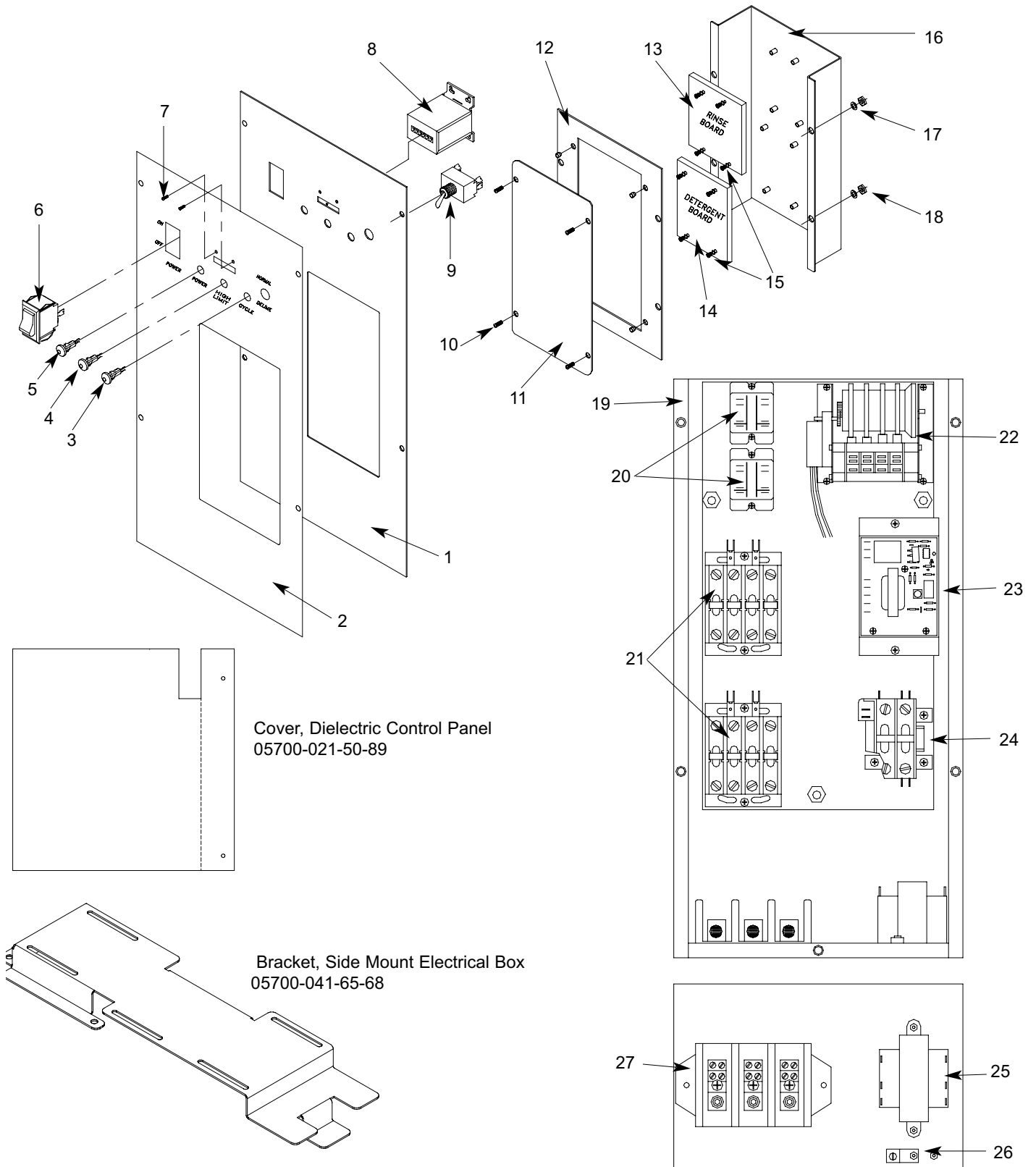

Cover, Dielectric Control Panel
05700-021-50-89

Bracket, Side Mount Electrical Box
05700-041-65-68

SECTION 5: PARTS SECTION

SDS SIDE MOUNTED CONTROL BOX ASSEMBLY (CONTINUED)

ITEM	QTY	DESCRIPTION	Mfg. No.
1	1	Control Box Cover Weldment	05700-021-60-43
2	1	Decal, Control Box Cover	09905-021-50-13
3	1	Light, Amber	05945-504-06-18
4	1	Light, Green	05945-504-08-18
5	1	Light, Red	05945-504-07-18
6	1	Manual Wash Switch	05930-301-46-00
7	2	Screw, 4-40 x 1/4" Phillips Panhead	05305-011-36-92
8	1	Cycle Counter	05990-111-47-42
9	1	Wash Switch	05930-301-21-18
10	4	Screw, 10-32 x 3/8" Phillips Panhead	05305-173-04-00
11	1	Cover, Electrical Box Panel	05700-011-49-23
12	1	Frame, Electrical Box Cover Panel	05700-011-49-22
13	1	Board, PC Rinse	06680-111-50-55
14	1	Board, PC Detergent	06680-111-50-54
15	8	Screw, 6-32 x 3/8" Long	05305-171-02-00
16	1	Bracket, PC Board	05700-011-49-24
17	4	Lockwasher, #10 Internal Tooth	05311-011-59-51
18	4	Locknut, 10-24 w/Nylon Insert	05310-373-01-00
19	1	Control Box Weldment	05700-041-47-55
20	2	Relay, Top Mount, Control	05945-111-47-51
21	2	Contact, 220V, 4 Pole	05945-109-01-69
22	1	Timer, 60 HZ	05945-303-31-00
23	1	Liquid Level Control Board	06680-200-08-21
24	1	Contact, 220V, 2 Pole	05945-109-03-69
24	1	Wash Motor Contactor (460 Volt Unit)	05945-002-14-78
24	1	Overload (460 Volt Unit)	05945-002-33-42
25	1	Transformer	05950-400-01-35
25	1	Transformer (380 Volt Unit)	05950-111-64-17
25	1	Transformer (460 Volt Unit)	05950-111-65-93
26	1	Ground Lug	05940-200-76-00
27	1	3 Pole Terminal Block	05940-011-48-27
28*	1	Fuse Holder (460 Volt Unit)	05940-401-03-14
29*	1	Circuit Breaker, 2 AMP (460 Volt Unit)	05925-111-64-18
Other components not shown:			
		Connector, 1/2", 90° Plastic	05975-011-45-14
		Connector, 3/4", 45° Plastic	05975-011-47-74
		Connector, 1/2", 45° Plastic	05975-011-45-23
		Connector, 1/2", 90° Metal	05975-111-01-00
		Grommet, 1/2" OD x 3/8" ID	05325-011-46-73
		Grommet, 7/8" Split	05975-200-40-00
		Plug, 1/2"	05975-011-47-81
		Decal, Delime/Normal	09905-011-34-96
		Decal, L1, L2, L3	09905-101-12-66
		Decal, Copper Conductors	09905-011-47-35
		Decal, Ground	09905-011-86-86

SECTION 5: PARTS SECTION
HOOD ASSEMBLY

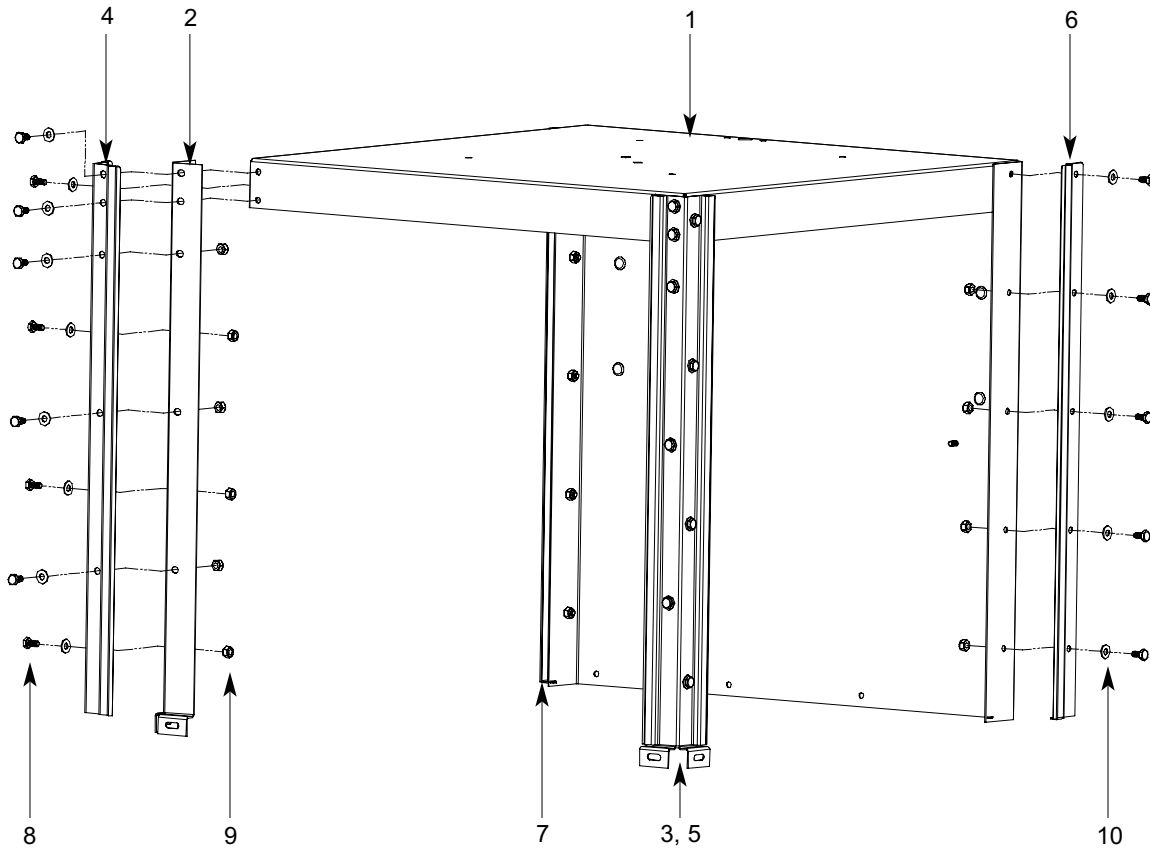

Switch Box Weldment
05700-002-14-34

SDS Switch Box Weldment
05700-002-30-98

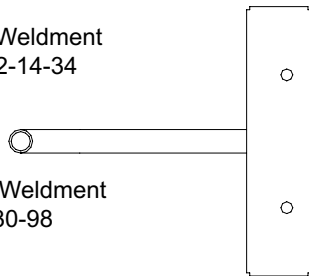

Magnetic Reed Switch
05930-003-05-84

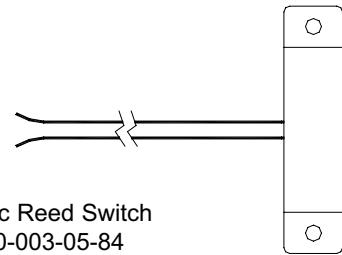

ITEM	QTY	DESCRIPTION	Mfg. No.
1	1	Hood Weldment (Tempstar/Tempstar LT/Tempstar NB)	05700-041-94-39
1	1	Hood Weldment (Tempstar SDS)	05700-041-47-87
2	1	Left Front Hood Support	05700-021-33-18
3	1	Right Front Hood Support	05700-021-33-17
4	1	Double Door Guide, Front Left	05700-021-33-20
5	1	Double Door Guide, Front Right	05700-021-33-19
6	1	Guide, Right Rear	05700-021-84-70
7	1	Guide, Left Rear	05700-021-84-71
8	28	Screw, 1/4"-20 x 1/2" Long	05305-274-02-00
9	28	Locknut, 1/4"-20 with Nylon Insert	05310-374-01-00
10	28	Washer, 1/4"-20 ID, S/S, Flat	05311-174-01-00

SECTION 5: PARTS SECTION
HOOD ASSEMBLY (BOLTED SINGLE SUPPORT DESIGN)

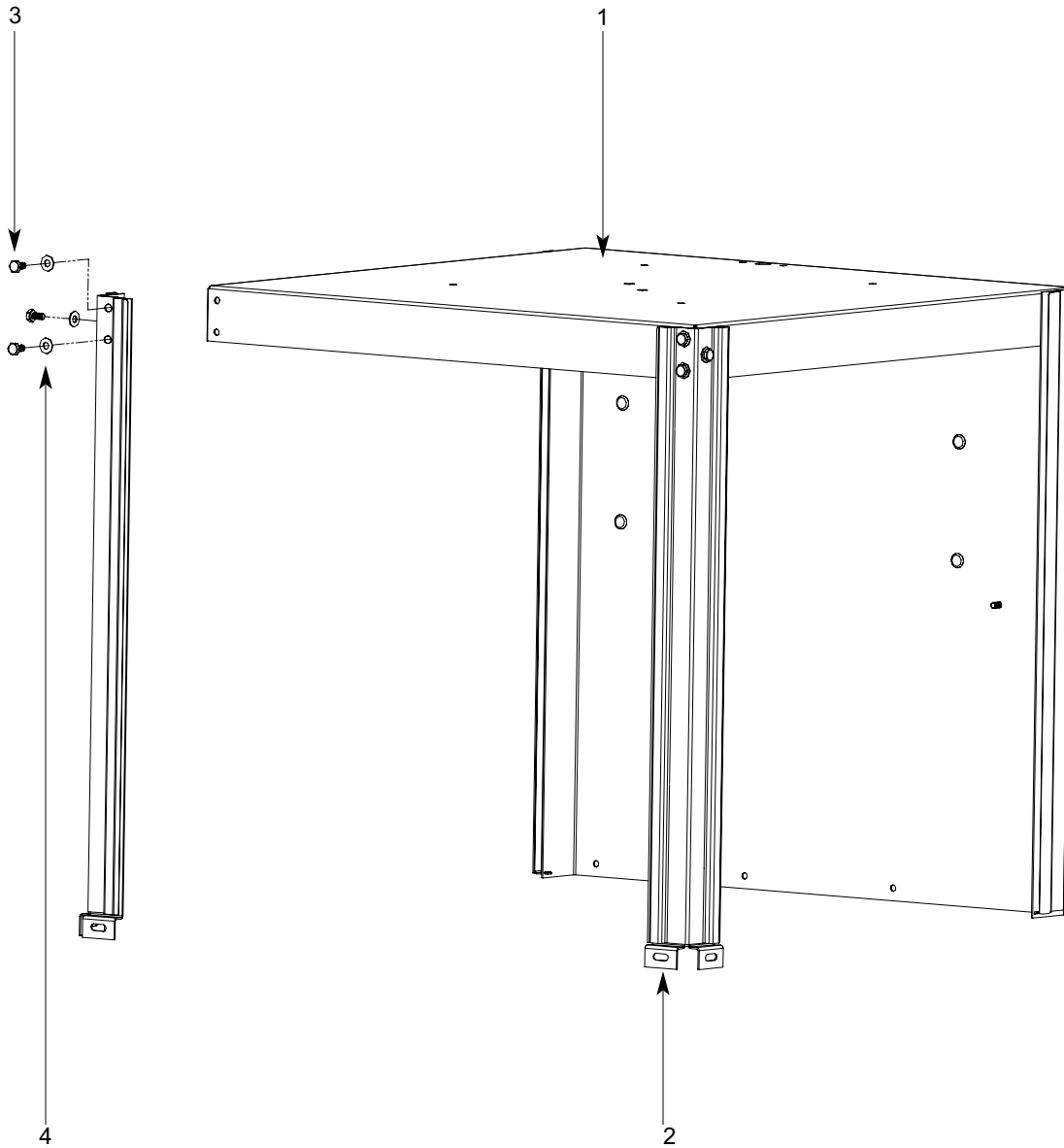

ITEM	QTY	DESCRIPTION	Mfg. No.
1	1	Hood Weldment (Tempstar/Tempstar LT/Tempstar NB)	05700-002-29-79
1	1	Hood Weldment (Tempstar SDS)	05700-002-36-91
2	2	Hood Support	05700-002-78-99
3	6	Bolt, 1/4"-20 x 1/2" Long	05305-274-21-00
4	6	Washer, Flat, SS, 1/4"-20 ID	05311-174-01-00
5	6	Locknut, 1/4"-20 with Nylon Insert (Not Shown)	05310-374-01-00
6	4	Block Spacer	05700-002-81-02

SECTION 5: PARTS SECTION
CANTILEVER ARM/DOOR ASSEMBLIES

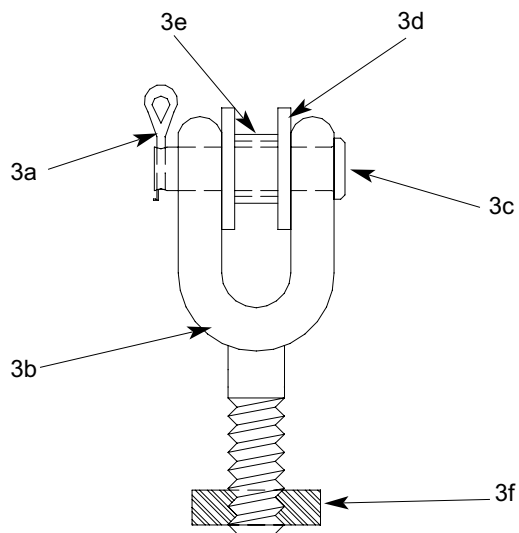
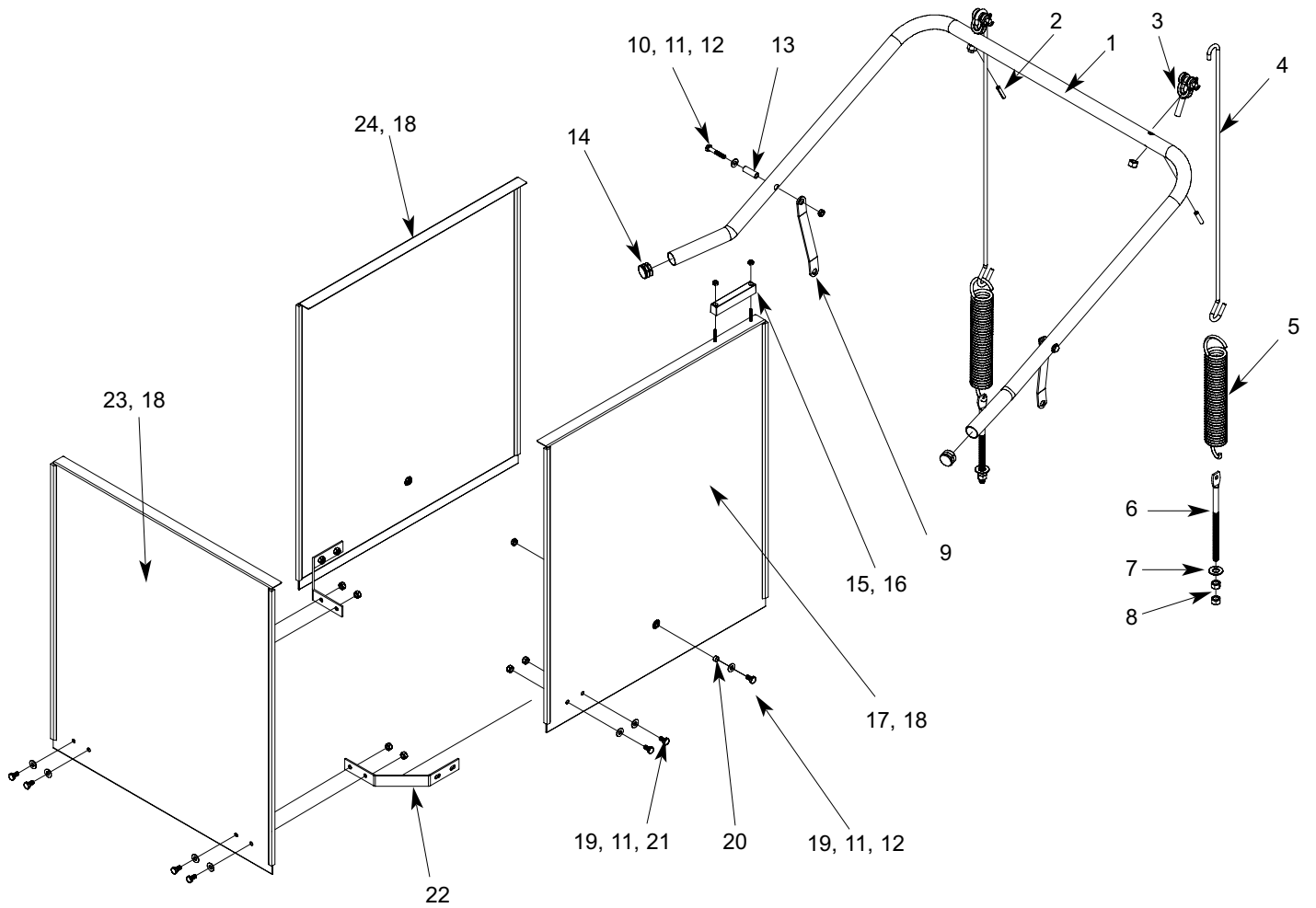

SECTION 5: PARTS SECTION
CANTILEVER ARM/DOOR ASSEMBLIES (CONTINUED)

ITEM	QTY	DESCRIPTION	Mfg. No.
1	1	Cantilever Arm	05700-031-50-67
2	2	Spring Pin, 1/4" x 1 1/8"	05315-407-06-00
3	2	Yoke Assembly	05700-000-75-77
3a	1	Cotter Pin	05315-207-01-00
3b	1	Yoke	05700-000-75-78
3c	1	Clevis Pin, 5/16" x 1 3/8"	05315-700-01-00
3d	2	Nylon Washer	05311-369-03-00
3e	1	Bushing	03120-100-03-00
3f	2	Locknut, 3/8"-16 S/S Hex Center	05310-256-04-00
4	2	Rod, Spring	05700-002-29-38
5	2	Spring	005340-109-02-
00			
6	2	Bolt, Cantilever Hanger Eye 3/8"-16	05306-956-05-00
7	2	Washer, 3/8" ID x 7/8" OD S/S	05311-176-02-00
8	4	Nut, 3/8"-16 S/S Hex	05310-276-01-00
9	2	Connector, Cantilever Arm	05700-011-90-99
10	2	Screw, 1/4"-20 x 1 1/2" Long S/S	05305-274-23-00
11	4	Washer, 1/4" S/S	05311-174-01-00
12	4	Locknut, 1/4"-20 S/S Hex with Nylon Insert Low Profile	05310-374-02-00
13	2	Sleeve, Cantilever Arm	05700-000-85-69
14	2	Plug, Cantilever Arm	05340-011-35-00
15	1	Magnet, Reed Switch	05930-111-51-68
16	2	Locknut, 8-32 S/S Hex with Nylon Insert	05310-272-02-00
17	1	Door, Right Side (Complete Assembly)	05700-002-30-88
17A	1	Right Door Weldment with Studs	05700-002-29-85
18	6	Door, Guides	05700-111-33-59
19	2	Screw, 1/4"-20 x 1/2" Long S/S	05305-274-02-00
20	2	Spacer, PB Bolt	05700-000-29-40
21	4	Locknut, 1/4"-20 S/S Hex with Nylon Insert	05310-374-01-00
22	2	Door Connector Bracket	05700-021-33-39
23	1	Door, Front (Complete Assembly)	05700-002-30-89
23A	1	Door Only, Front	05700-002-29-83
24	1	Door, Left Side (Complete Assembly)	05700-002-30-87
24A	1	Door Only, Left Side	05700-002-29-86
25	4	Door Connecting Plate	05700-002-20-78
26*	2	Bracket, Cantilever Arm Support	05700-031-88-00
27*	6	Wear Button, 1/2" Dia. UHMW	05700-011-88-01

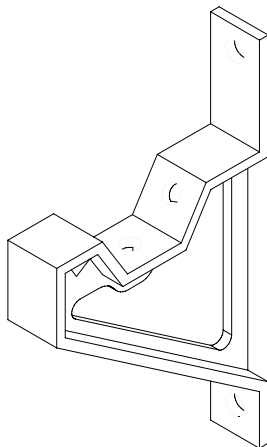

Bracket, Cantilever Arm Support
09515-003-15-64

Wear Button, 1/2" Dia. UHMW
05700-011-88-01

SECTION 5: PARTS SECTION

TUB ASSEMBLY

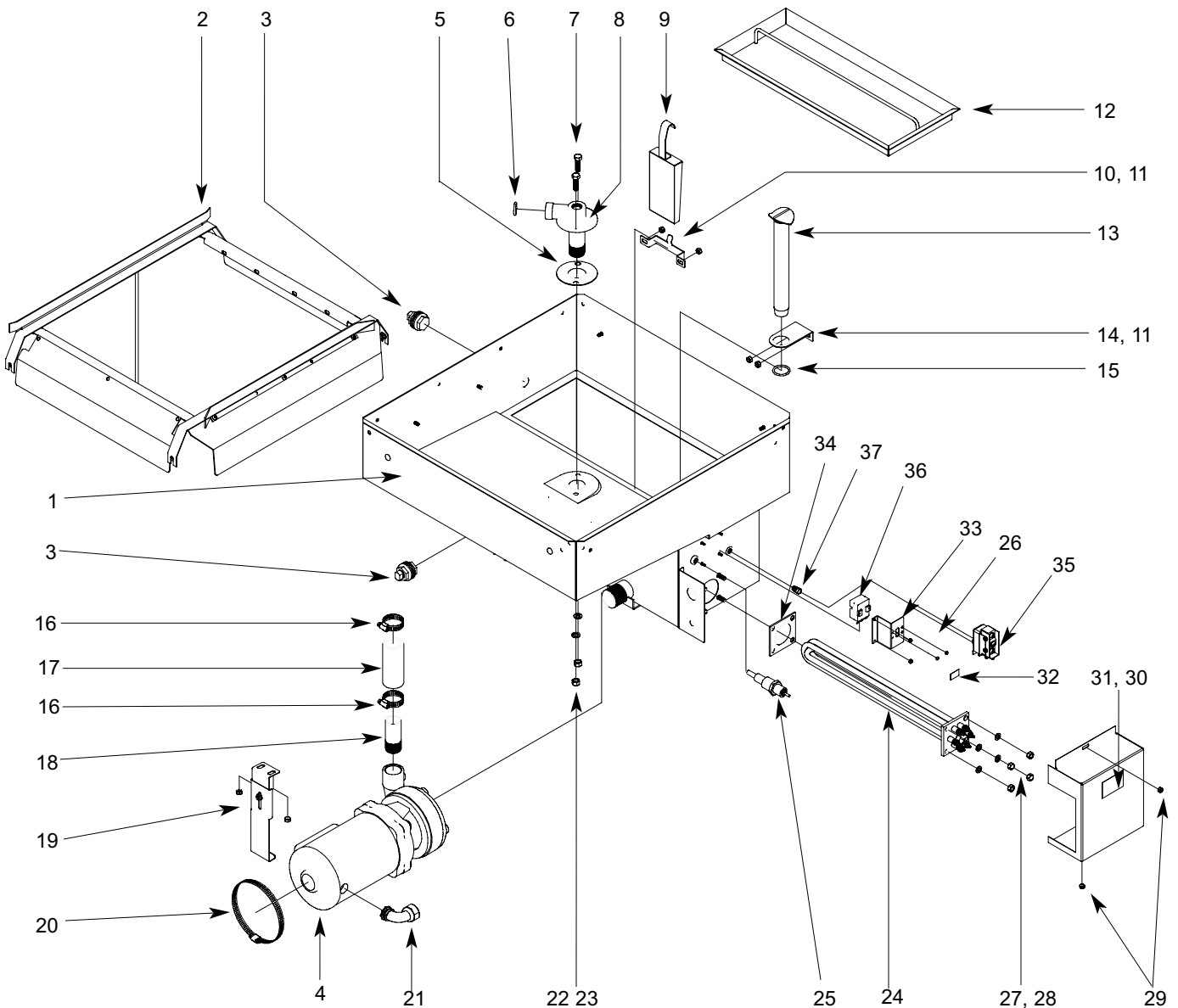

* Represents an item not shown.

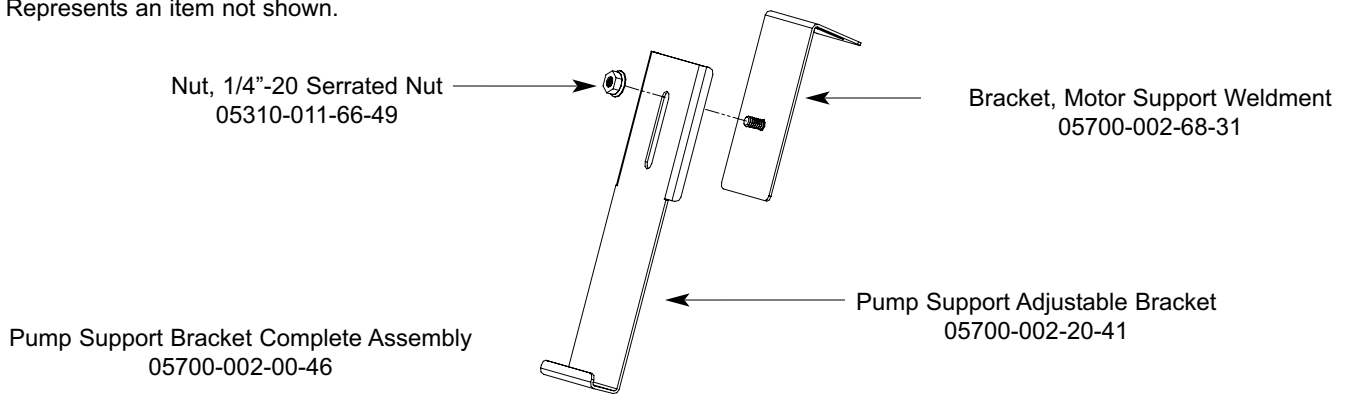

SECTION 5: PARTS SECTION**TUB ASSEMBLY (CONTINUED)**

ITEM	QTY	DESCRIPTION	Mfg. No.
1	1	Tub Weldment	05700-002-12-59
2	1	Rack Assembly	05700-002-01-00
3	2	Bulk Head Plug	04730-609-05-00
4	1	See Page Entitled "Wash Motors"	N/A
5	1	Gasket	05700-111-35-03
6	1	O-ring	05330-400-05-00
7	4	Bolt, Hex 3/8"-16 x 1 1/4" Long	05305-276-10-00
8	1	Lower Wash Manifold Weldment	05700-031-46-00
9	1	Suction Strain Weldment	05700-001-22-23
10	1	Suction Strain Bracket	05700-001-22-24
11	8	Locknut, 1/4"-20 with Nylon Insert	05310-374-02-00
12	1	Strainer Weldment	05700-021-50-07
13	1	Wash Overflow Weldment	05700-001-25-69
*	1	Support, Ball Stop Lift	05700-002-91-55
*	1	Ball Stop Lift	05700-002-91-54
*	1	Shim, Overflow Support	05700-002-96-48
14	1	Overflow Support Bracket	05700-001-27-55
15	1	O-Ring	05330-400-05-00
16	2	Clamp, Hose 1 5/16" to 2 1/4"	04730-719-01-37
17	1	Discharge Hose	05700-011-88-24
18	1	Nipple	05700-021-34-84
19	1	Pump Support Bracket Assembly	05700-002-00-46
20	1	Clamp, Hose 5 5/8" to 6"	04730-011-34-90
21	1	Connector, 1/2" 90°	05975-111-01-00
22	4	Nut, 3/8"-16 S/S Hex	05310-276-01-00
23	4	Lockwasher 3/8"	05311-276-01-00
24	1	See Page Entitled "Wash Heaters/Rinse Heaters" See page 27 to order phase conversion kits for the heater.	N/A
25	1	Probe, High Water	06680-200-02-68
26	5	Locknut, 6-32 with Nylon Insert	05310-373-03-00
27	4	Lockwasher, 5/16", S/S, Split	05311-275-01-00
28	4	Nut, Hex, 5/16"-18, S/S	05310-275-01-00
29	4	Locknut, 10-24 with Nylon Insert	05310-373-01-00
30	1	Cover, Wash Heater	05700-031-47-57
31	1	Decal, Warning-Disconnect Power	09905-100-75-93
32	1	Decal, High Limit	09905-011-84-32
33	1	Thermostat Bracket	05700-011-81-64
34	1	Wash Heater Gasket	05330-011-47-79
35	1	Thermostat, Regulating	05930-510-02-79
	1	Kit, Wash Thermostat Replacement (Includes: thermostat, brass fitting, 2 jumper wires & instructions)	06401-003-18-22
36	1	Thermostat, High Limit	05930-011-49-43
37	1	Fitting, 1/4" Imperial Brass	05310-924-02-05
Items for side-mounted control box not shown:			
*	1	Gauge Bracket (Side Mount Control Box Only)	05700-011-48-08
*	1	Thermometer, Wash (Side Mount Control Box Only)	06685-111-40-38
*	1	Thermometer, Rinse (Side Mount Control Box Only)	06685-111-40-39

SECTION 5: PARTS SECTION

STEAM TUB ASSEMBLY

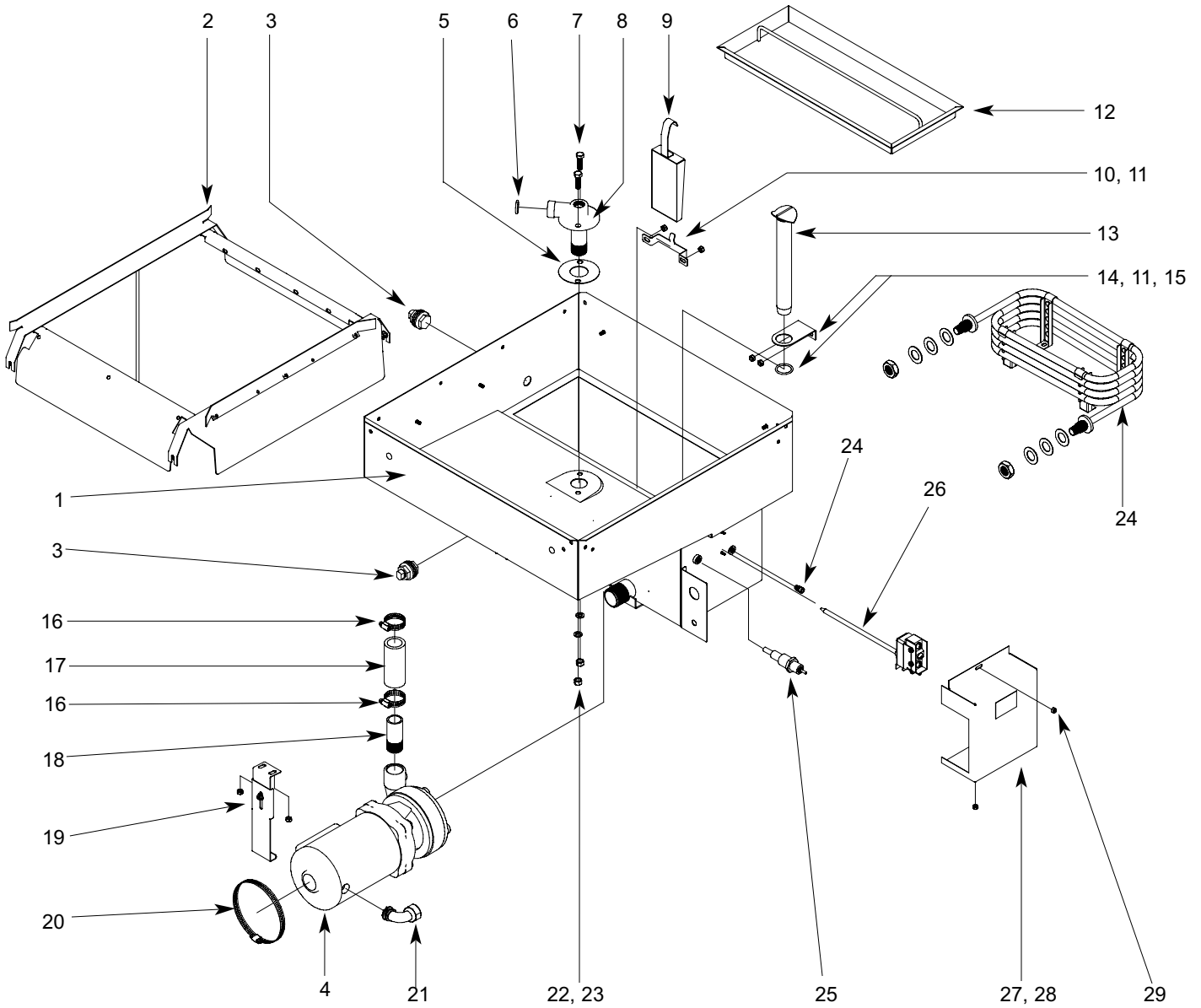

* Represents an item not shown.

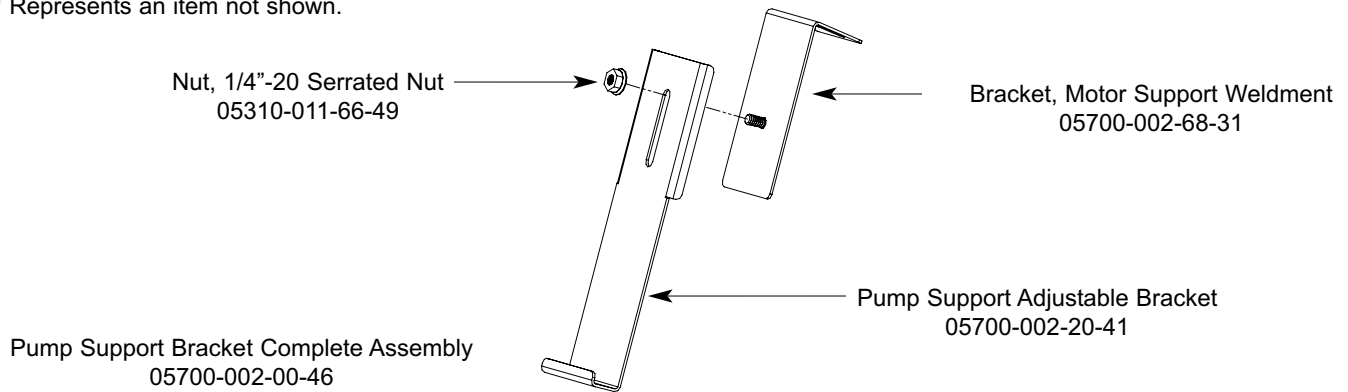

SECTION 5: PARTS SECTION
STEAM TUB ASSEMBLY (CONTINUED)

ITEM	QTY	DESCRIPTION	Mfg. No.
1	1	Tub Weldment	05700-002-09-26
2	1	Rack Assembly	05700-002-01-00
3	2	Bulk Head Plug	04730-609-05-00
4	1	See page entitled "Wash Motors"	N/A
5	1	Gasket	05700-111-35-03
6	1	O-ring	05330-400-05-00
7	4	Bolt, Hex 3/8"-16 x 1 1/4" Long	05305-276-10-00
8	1	Lower Wash Manifold Weldment	05700-031-46-00
9	1	Suction Strain Weldment	05700-001-22-23
10	1	Suction Strain Bracket	05700-001-22-24
11	8	Locknut, 1/4"-20 with Nylon Insert	05310-374-02-00
12	1	Strainer Weldment	05700-021-50-07
13	1	Wash Overflow Weldment	05700-001-25-69
*	1	Support, Ball Stop Lift	05700-002-91-55
*	1	Ball Stop Lift	05700-002-91-54
*	1	Shim, Overflow Support	05700-002-96-48
14	1	Overflow Support Bracket	05700-001-27-55
15	1	O-Ring	05330-400-05-00
16	2	Clamp, Hose 1 5/16" to 2 1/4"	04730-719-01-37
17	1	Discharge Hose	05700-011-88-24
18	1	Nipple	05700-021-34-84
19	1	Pump Support Bracket Assembly	05700-002-00-46
20	1	Clamp, Hose 5 5/8" to 6"	04730-011-34-90
21	1	Connector, 1/2" 90 Deg.	05975-111-01-00
22	4	Nut, 3/8"-16 S/S Hex	05310-276-01-00
23	4	Lockwasher 3/8"	05311-276-01-00
24	1	Fitting, 1/4" Imperial Brass	05310-924-02-05
25	1	Probe, High Water	06680-200-02-68
26	1	Thermostat, Regulating	05930-510-02-79
	1	Kit, Wash Thermostat Replacement (Includes: thermostat, brass fitting, 2 jumper wires & instructions)	06401-003-18-67
27	1	Cover, Wash Heater	05700-031-47-57
28	1	Decal, Warning-Disconnect Power	09905-100-75-93
29	2	Locknut, 10-24 with Nylon Insert	05310-373-01-00
30	3	Locknut, 6-32 with Nylon Insert	05310-373-03-00

SECTION 5: PARTS SECTION

FRAME ASSEMBLY

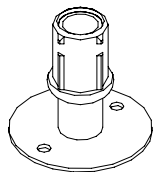
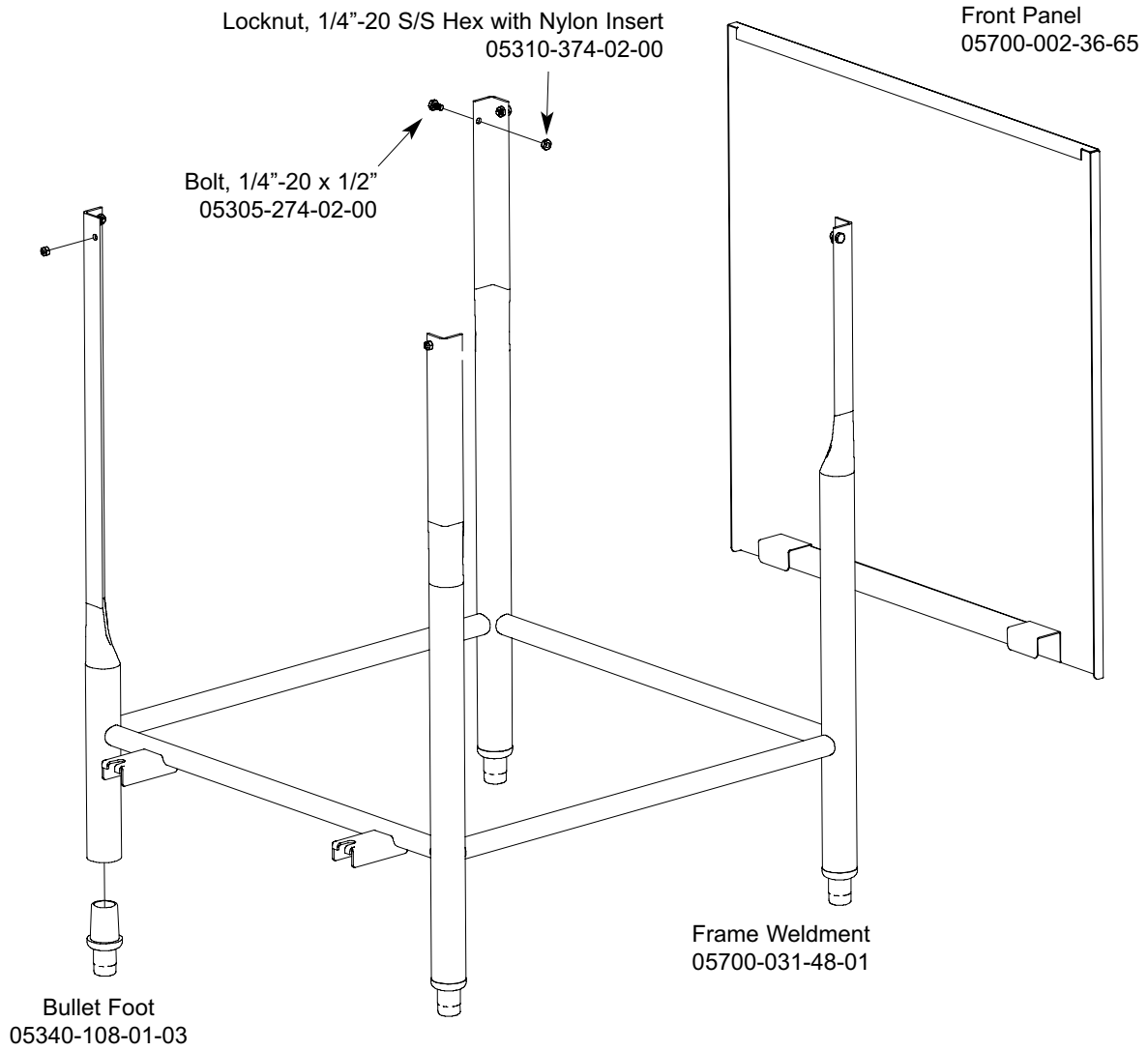

Flanged Bullet Foot
05340-002-34-86

SECTION 5: PARTS SECTION

RINSE TANK ASSEMBLY

See page 27 to order phase conversion kits for the heater.

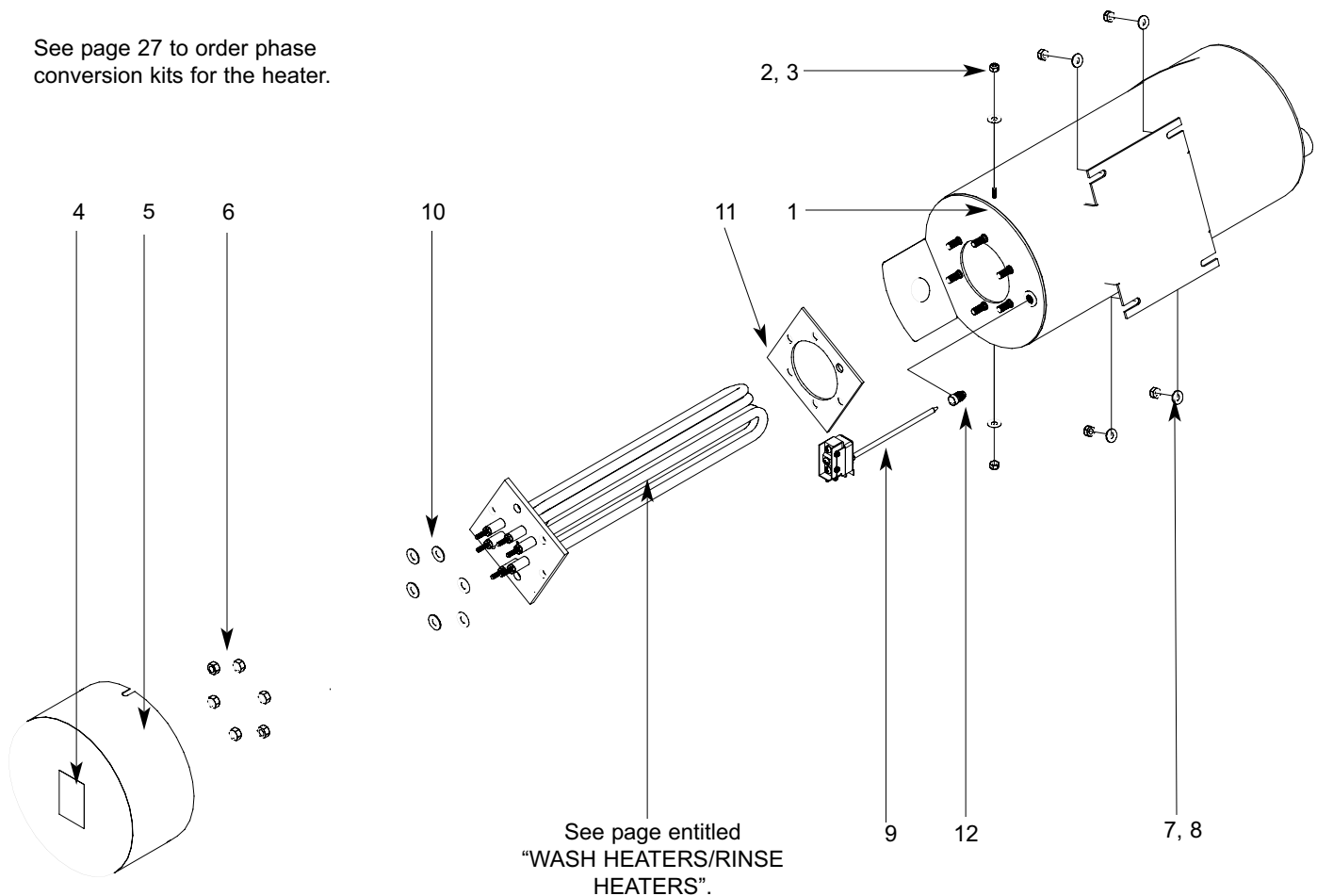

ITEM	QTY	DESCRIPTION	Mfg. No.
1	1	Booster Tank Weldment	05700-001-22-02
2	2	Locknut, 10-24 with Nylon Insert	05310-373-01-00
3	2	Washer, #10 S/S Flat	05311-173-01-00
4	1	Decal, Warning - Disconnect Power	09905-100-75-93
5	1	Booster Tank Cover Weldment	05700-001-29-30
6	6	Nut, Hex, 5/16"-18	05310-275-01-00
7	4	Locknut, 1/4"-20 with Nylon Insert	05310-374-01-00
8	4	Washer, 1/4" ID, S/S, Flat	05311-174-01-00
9	1	Thermostat, Rinse	05930-510-03-79
	1	Kit, Rinse Thermostat Replacement (Includes: thermostat, brass fitting, 2 jumper wires & instructions)	06401-011-66-55
10	6	Washer, 5/16" I.D.	05311-175-01-00
11	1	Gasket, Rinse Heater	05330-200-02-70
12	1	Fitting, 1/4" Imperial Brass	05310-924-02-05

SECTION 5: PARTS SECTION
COIL ASSEMBLY

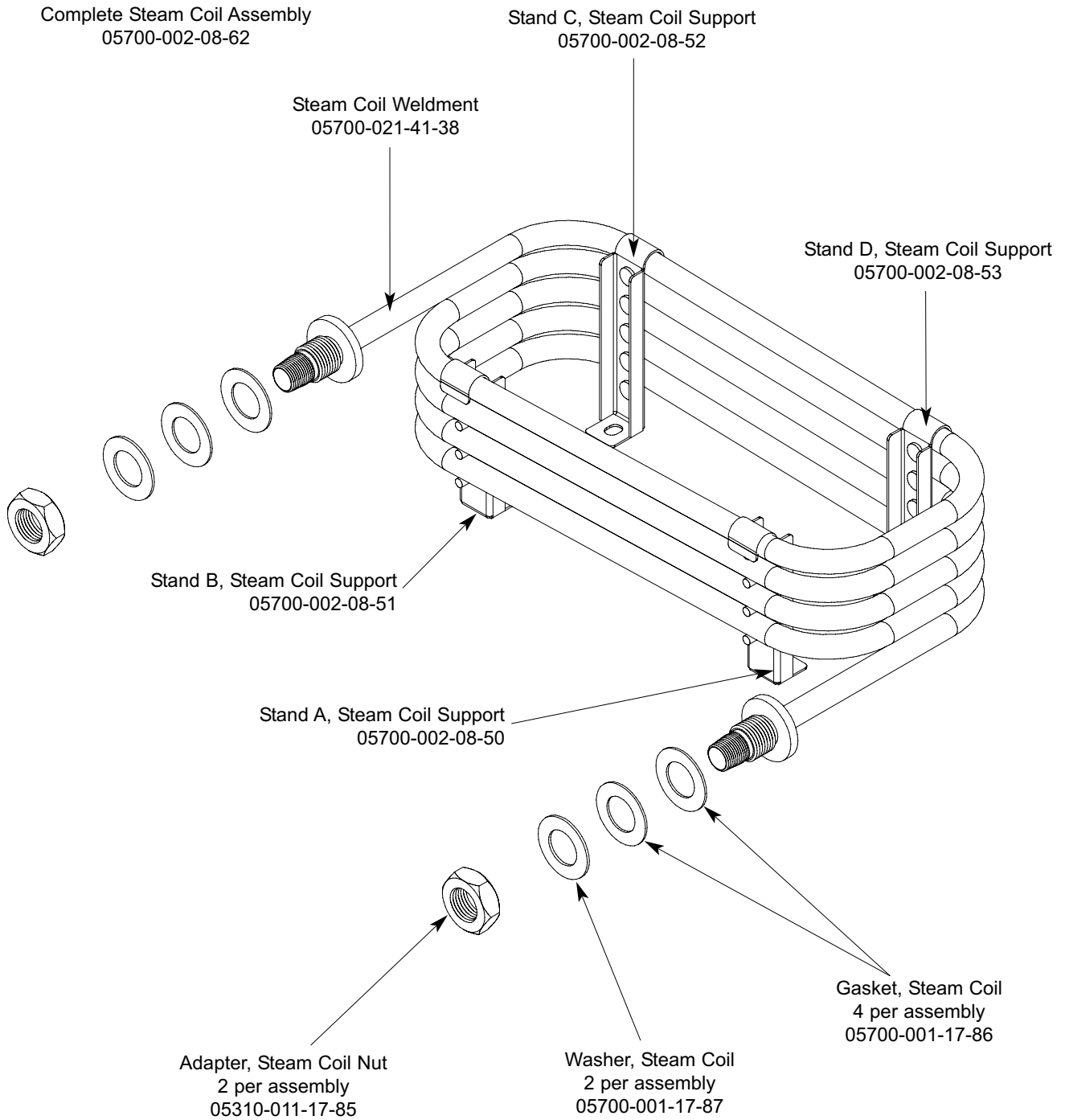

SECTION 5: PARTS SECTION

INCOMING STEAM PLUMBING ASSEMBLIES

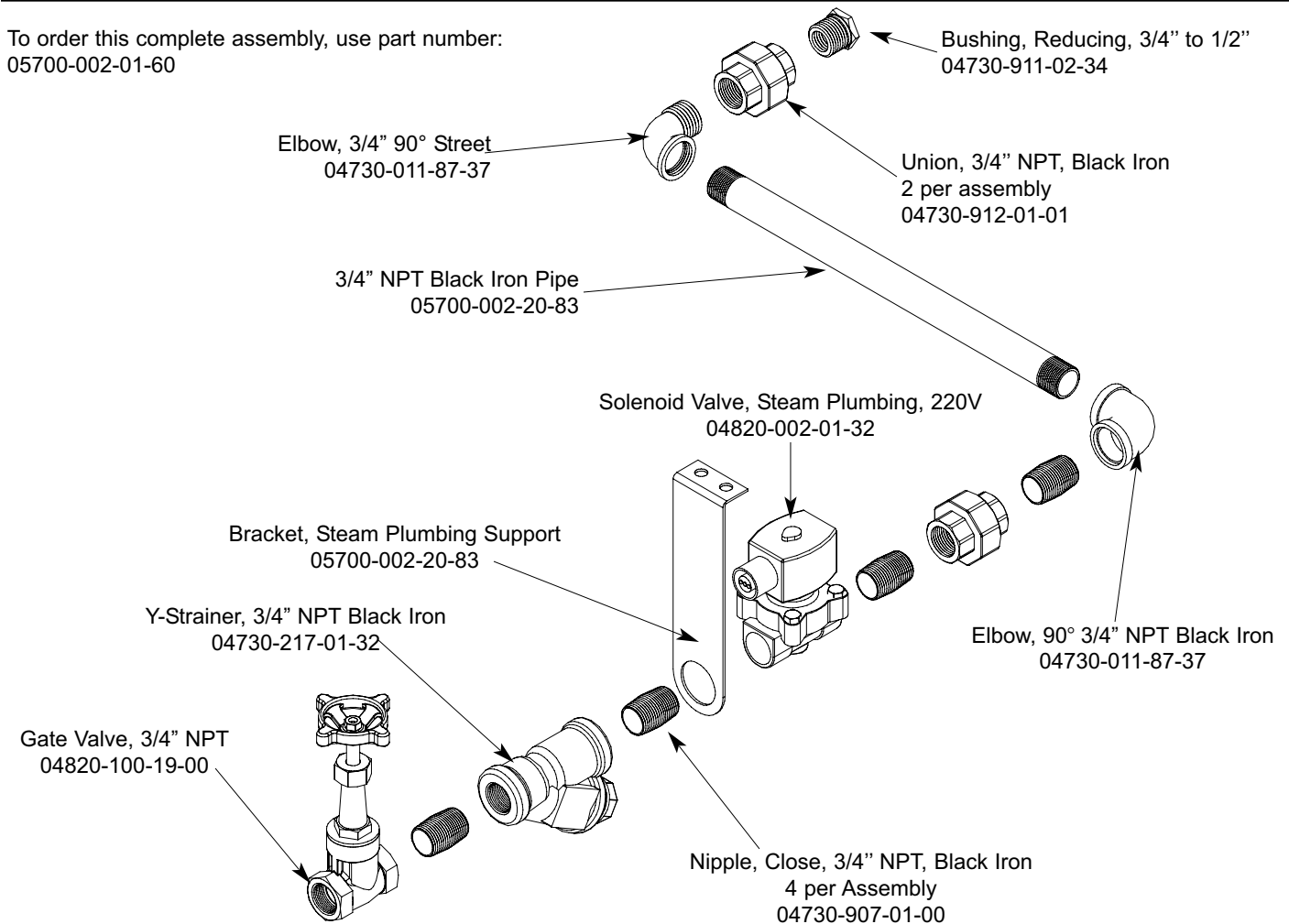
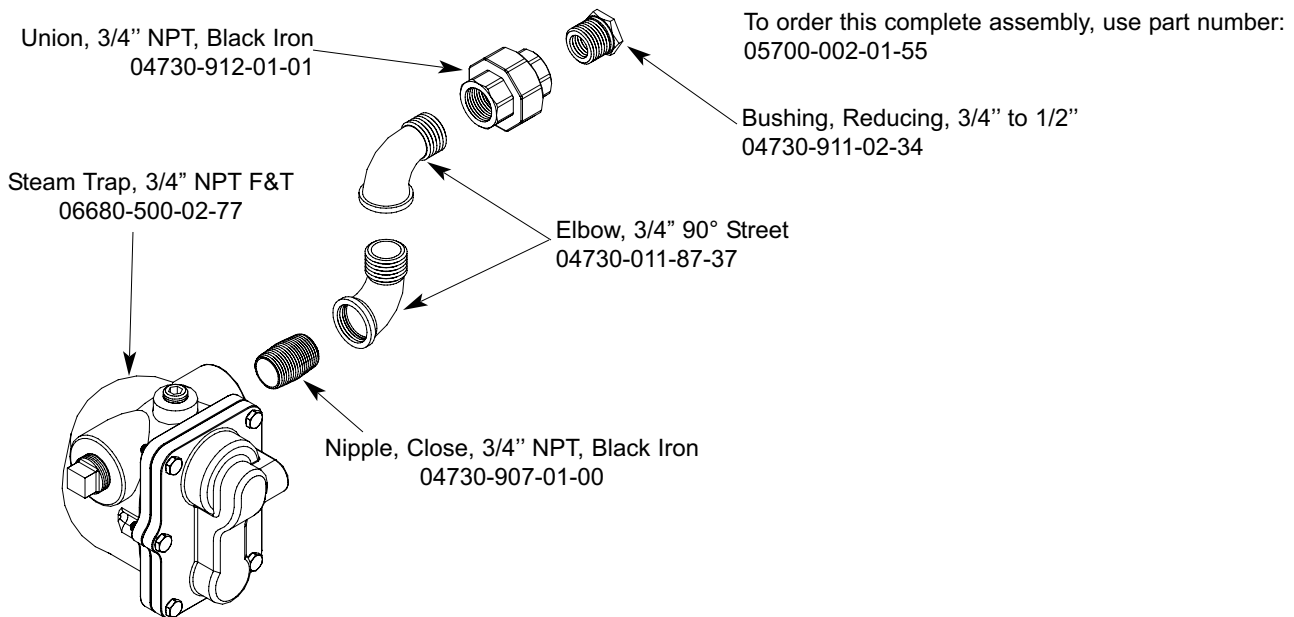

SECTION 5: PARTS SECTION

WASH MOTORS

The Tempstar models covered in this manual come supplied with various wash motor assemblies (a wash motor assembly includes the wash motor and the pump end), depending on the characteristics of the machine. To ensure that you order the correct wash motor assembly for the model you are servicing, please refer to the following table:

<u>Model</u>	<u>Volts</u>	<u>Hz</u>	<u>Phase</u>	<u>Wash Motor Assembly</u>
Tempstar/Tempstar NB	208	50	1	06105-002-19-87
Tempstar/Tempstar NB	208	50	3	06105-002-19-87
Tempstar/Tempstar NB	208	60	1	06105-002-69-78
Tempstar/Tempstar NB	208	60	3	06105-002-69-78
Tempstar/Tempstar NB	230	50	1	06105-002-19-87
Tempstar/Tempstar NB	230	50	3	06105-002-19-87
Tempstar/Tempstar NB	230	60	1	06105-002-69-78
Tempstar/Tempstar NB	230	60	3	06105-002-69-78
Tempstar/Tempstar NB	380	50	3	06105-002-41-24
Tempstar/Tempstar NB	415	50	3	06105-002-41-24
Tempstar/Tempstar NB	440	50	3	06105-002-41-24
Tempstar/Tempstar NB	460	60	3	06105-121-64-21
Tempstar LT	208	50	1	06105-002-19-87
Tempstar LT	208	50	3	06105-002-19-87
Tempstar LT	208	60	1	06105-002-69-78
Tempstar LT	208	60	3	06105-002-69-78
Tempstar LT	230	50	1	06105-002-19-87
Tempstar LT	230	50	3	06105-002-19-87
Tempstar LT	230	60	1	06105-002-69-78
Tempstar LT	230	60	3	06105-002-69-78
Tempstar LT	380	50	3	06105-002-41-24
Tempstar LT	415	50	3	06105-002-41-24
Tempstar LT	440	50	3	06105-002-41-24
Tempstar LT	460	60	3	06105-121-64-21
Tempstar SDS	208	50	1	06105-002-19-87
Tempstar SDS	208	50	3	06105-002-19-87
Tempstar SDS	208	60	1	06105-002-69-78
Tempstar SDS	208	60	3	06105-002-69-78
Tempstar SDS	230	50	1	06105-002-19-87
Tempstar SDS	230	50	3	06105-002-19-87
Tempstar SDS	230	60	1	06105-002-69-78
Tempstar SDS	230	60	3	06105-002-69-78
Tempstar SDS	380	50	3	06105-002-41-24
Tempstar SDS	415	50	3	06105-002-41-24
Tempstar SDS	440	50	3	06105-002-41-24
Tempstar SDS	460	60	3	06105-121-64-21
Tempstar S	208	60	1	06105-002-69-78
Tempstar S	208	60	3	06105-002-69-78
Tempstar S	230	60	1	06105-002-69-78
Tempstar S	230	60	3	06105-002-69-78

Important note: When servicing a wash motor, it is important to refer to the wiring schematic found on the motor, to ensure that the motor is wired correctly. Different manufacturers of motors may not use the same wire color codes and therefore, your new motor, which may have been built by someone different than who built your original motor, may not connect using the same wires. Always refer to the wiring diagrams on the motor you are installing. If the motor you are installing has had the schematic removed, contact Jackson MSC immediately for technical support.

SECTION 5: PARTS SECTION

MOTOR & PUMP ASSEMBLY

Complete Pump & Motor Assembly, 60HZ
06105-002-69-78

Complete Pump & Motor Assembly, 50HZ
06105-002-19-87

Motor Only, 60HZ
06105-002-79-61

Pump Only Assembly, 60HZ
(Area indicated within box, Casing is included)
05700-002-79-51

Pump Only Assembly, 50HZ
(Area indicated within box, Casing is included)
05700-002-85-38

Motor Only, 50HZ
06105-002-85-36

Pump Casing (Not shown), 50HZ
05700-002-41-50

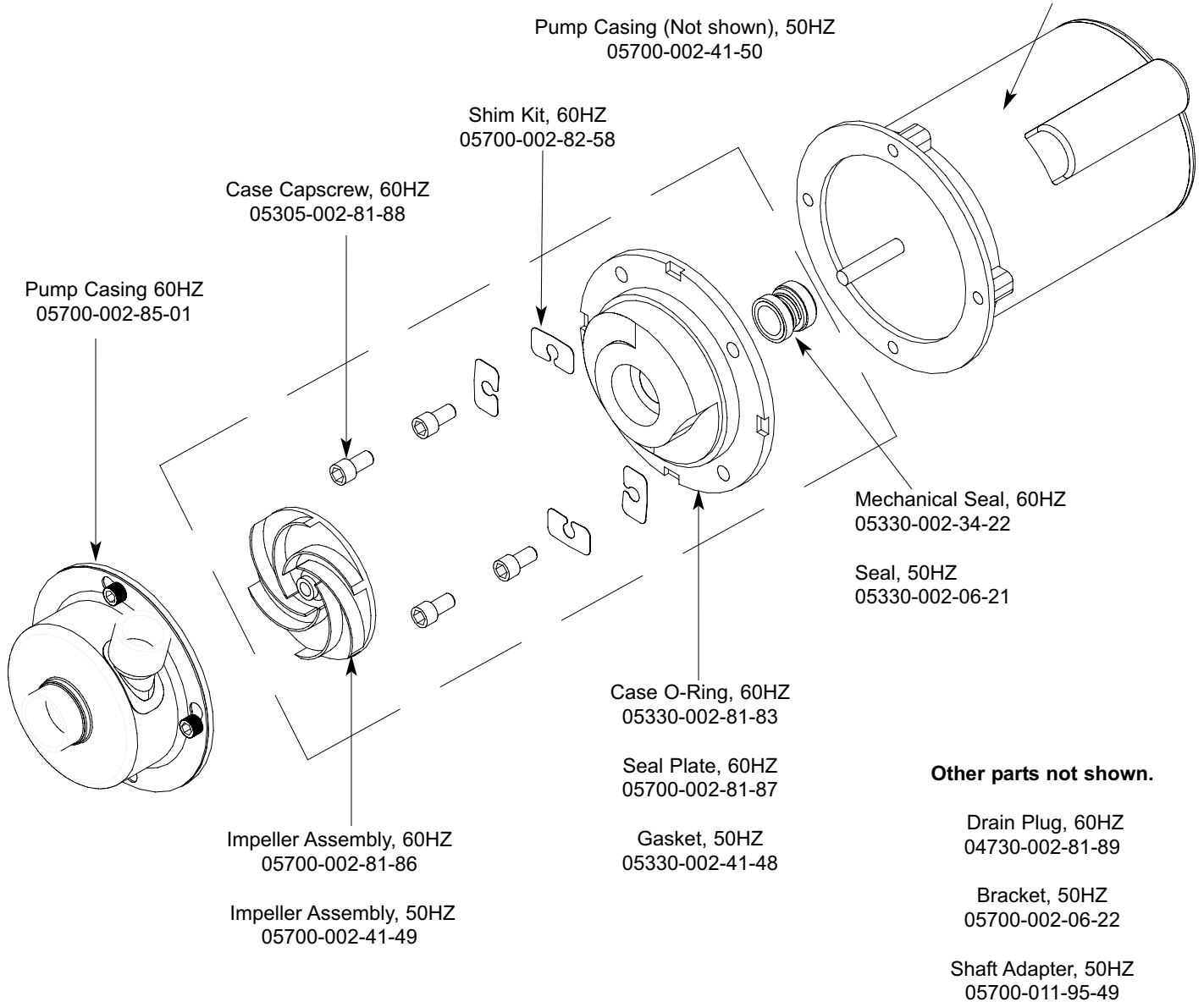

SECTION 5: PARTS SECTION

WASH HEATERS/RINSE HEATERS

The Tempstar models covered in this manual come supplied with various heaters, depending on the characteristics of the machine. To ensure that you order the correct heater for the model you are servicing, please refer to the following table:

Model	Volts	Hz	Phase	Wash Heater	Rinse Heater (12 KW)	Rinse Heater (14 KW)
Tempstar	208	50	1	04540-121-47-39	04540-121-47-40	04540-121-63-38
Tempstar	208	50	3	04540-121-47-39	04540-121-47-40	04540-121-63-38
Tempstar	208	60	1	04540-121-47-39	04540-121-47-40	04540-121-63-38
Tempstar	208	60	3	04540-121-47-39	04540-121-47-40	04540-121-63-38
Tempstar	230	50	1	04540-121-47-39	04540-121-47-40	04540-121-63-38
Tempstar	230	50	3	04540-121-47-39	04540-121-47-40	04540-121-63-38
Tempstar	230	60	1	04540-121-47-39	04540-121-47-40	04540-121-63-38
Tempstar	230	60	3	04540-121-47-39	04540-121-47-40	04540-121-63-38
Tempstar	380	50	3	04540-002-44-31	04540-002-44-32	04540-121-63-38
Tempstar	415	50	3	04540-002-43-09	04540-002-43-10	04540-002-77-24
Tempstar	440	50	3	04540-121-65-99	04540-100-01-15	04540-121-63-39
Tempstar	460	60	3	04540-121-65-99	04540-100-01-15	04540-121-63-39
Tempstar LT	208	50	1	04540-121-47-39		
Tempstar LT	208	50	3	04540-121-47-39		
Tempstar LT	208	60	1	04540-121-47-39		
Tempstar LT	208	60	3	04540-121-47-39		
Tempstar LT	230	50	1	04540-121-47-39		
Tempstar LT	230	50	3	04540-121-47-39		
Tempstar LT	230	60	1	04540-121-47-39		
Tempstar LT	230	60	3	04540-121-47-39		
Tempstar LT	380	50	3	04540-002-44-31		
Tempstar LT	440	50	3	04540-121-65-99		
Tempstar LT	460	60	3	04540-121-65-99		
Tempstar NB	208	50	1	04540-121-47-39		
Tempstar NB	208	50	3	04540-121-47-39		
Tempstar NB	208	60	1	04540-121-47-39		
Tempstar NB	208	60	3	04540-121-47-39		
Tempstar NB	230	50	1	04540-121-47-39		
Tempstar NB	230	50	3	04540-121-47-39		
Tempstar NB	230	60	1	04540-121-47-39		
Tempstar NB	230	60	3	04540-121-47-39		
Tempstar NB	380	50	3	04540-002-44-31		
Tempstar NB	415	50	3	04540-002-43-09		
Tempstar NB	440	50	3	04540-121-65-99		
Tempstar NB	460	60	3	04540-121-65-99		
Tempstar SDS	208	50	1	04540-121-47-39	04540-121-47-40	04540-121-63-38
Tempstar SDS	208	50	3	04540-121-47-39	04540-121-47-40	04540-121-63-38
Tempstar SDS	208	60	1	04540-121-47-39	04540-121-47-40	04540-121-63-38
Tempstar SDS	208	60	3	04540-121-47-39	04540-121-47-40	04540-121-63-38
Tempstar SDS	230	50	1	04540-121-47-39	04540-121-47-40	04540-121-63-38
Tempstar SDS	230	50	3	04540-121-47-39	04540-121-47-40	04540-121-63-38
Tempstar SDS	230	60	1	04540-121-47-39	04540-121-47-40	04540-121-63-38
Tempstar SDS	230	60	3	04540-121-47-39	04540-121-47-40	04540-121-63-38
Tempstar SDS	380	50	3	04540-002-44-31	04540-002-44-32	04540-121-63-38
Tempstar SDS	415	50	3	04540-002-43-09	04540-002-43-10	04540-002-77-24
Tempstar SDS	440	50	3	04540-121-65-99	04540-100-01-15	04540-121-63-39
Tempstar SDS	460	60	3	04540-121-65-99	04540-100-01-15	04540-121-63-39

SECTION 5: PARTS SECTION

TEMPSTAR INCOMING PLUMBING/OUTLET PLUMBING ASSEMBLY

TEMPSTAR INCOMING PLUMBING

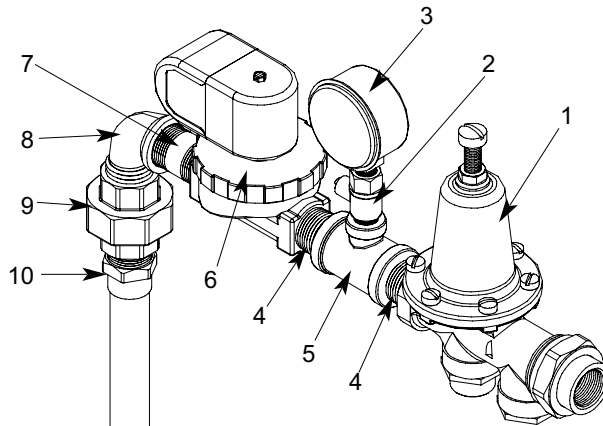

TEMPSTAR/TEMPSTAR SDS
OUTLET PLUMBING

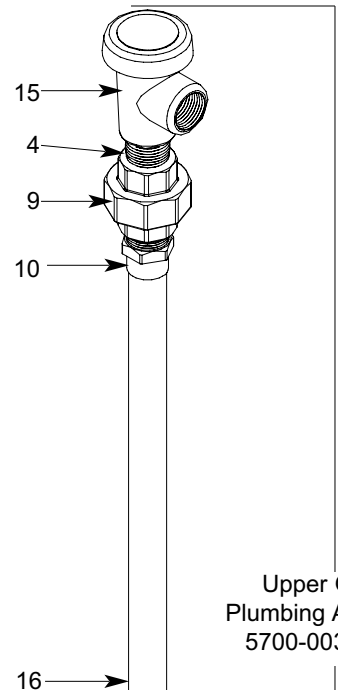

Tube Length Chart

Item #	Length (Inches)
11	3/4" x 36 1/4" Long
14	3/4" x 3 3/4" Long
16	3/4" x 30 3/4" Long
18	3/4" x 2 7/8" Long

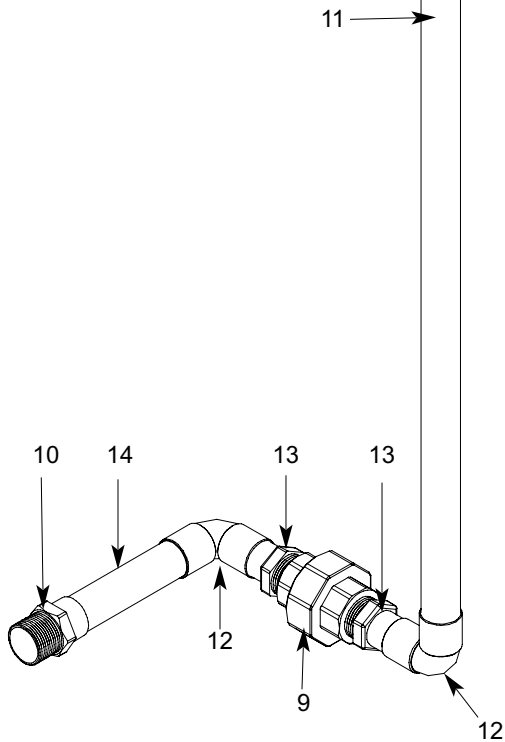

Lower Outlet
Plumbing Assembly
5700-003-20-36

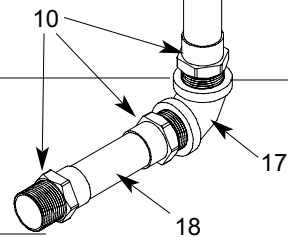

Upper Outlet
Plumbing Assembly
5700-003-20-37

SECTION 5: PARTS SECTION

TEMPSTAR INCOMING PLUMBING/OUTLET PLUMBING ASSEMBLY/WPRK KIT OPTION

ITEM	QTY	DESCRIPTION	Mfg. No.
1	1	Water Pressure Regulator, 3/4" NPT	06685-011-58-22
2	1	Valve, Ball, 1/4" NPT	04810-011-72-67
3	1	Gauge, Pressure, 0-100 PSI	06685-111-88-34
4	2	Nipple, Close, 3/4" NPT	04730-207-34-00
5	1	Tee, Brass, 3/4" NPT x 3/4" NPT x 1/4" NPT	04730-211-04-00
6	1	Valve, Solenoid, 3/4" NPT	04810-100-03-18
7	1	Nipple, Brass, 3/4" NPT x 2" Long	04730-207-46-00
8	1	Elbow, 3/4" NPT, Brass, Street	04730-206-04-34
9	3	Union, 3/4" NPT, Brass	04730-212-05-00
		O-ring	05330-003-
10	6	Adapter, 3/4" Male	04730-401-11-01
11	1	Tube, Copper	See Chart
12	2	Elbow, 3/4" CU x CU, 90°	04730-406-16-01
13	2	Adapter, 3/4", 604-2	04730-401-10-01
14	1	Tube, Copper	See Chart
15	1	Vacuum Breaker, 3/4" NPT	04820-002-53-77
16	1	Tube, Copper	See Chart
17	1	Elbow, 3/4" NPT, 90°, Brass	04730-206-13-00
18	1	Tube, Copper	See Chart

When servicing plumbing components, take care not to damage the threads of each individual item. Damaged threads can cause leaks and loss of pressure, which could adversely effect the performance of the Tempstar dishmachine. It is strongly recommended that teflon thread tape, used in conservative amounts, be applied to threads when joining components together. It is not advised to use thread sealing compounds, sometimes referred to as "pipe dope". Compounds can be ejected from the threads during the tightening process and become lodged in key components, thereby rendering them useless. Some of the components include the solenoid valve and the pressure gauge isolation ball valve.

WPRK KIT OPTION

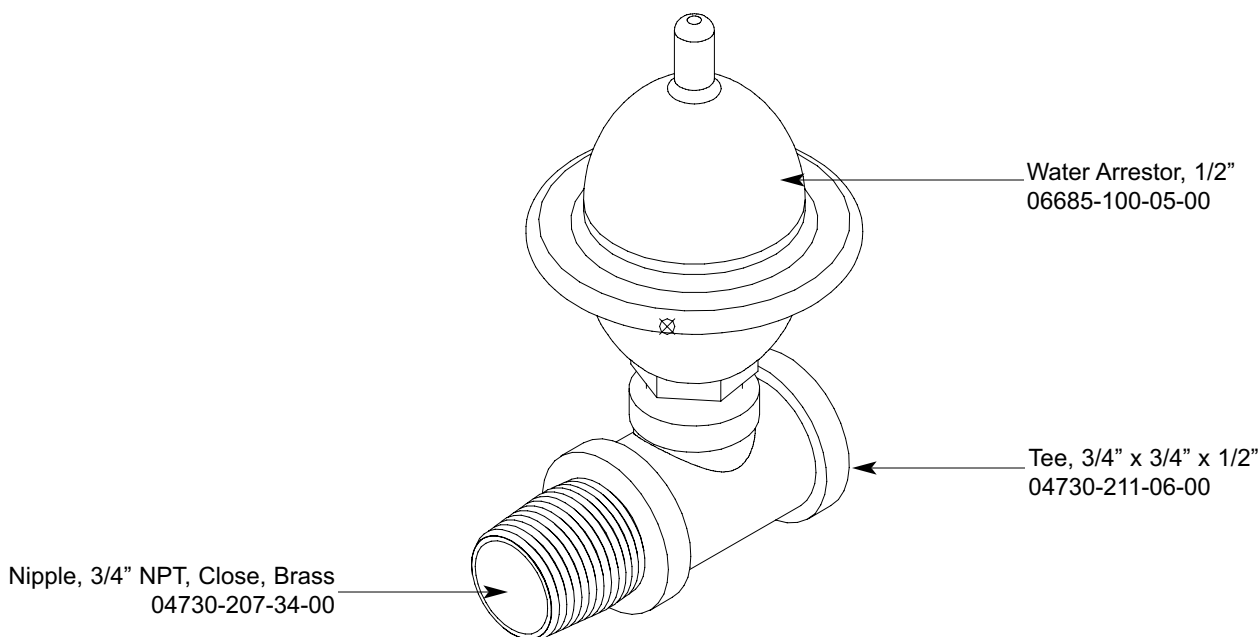

SECTION 5: PARTS SECTION
TEMPSTAR LT & TEMPSTAR NB INCOMING PLUMBING ASSEMBLY

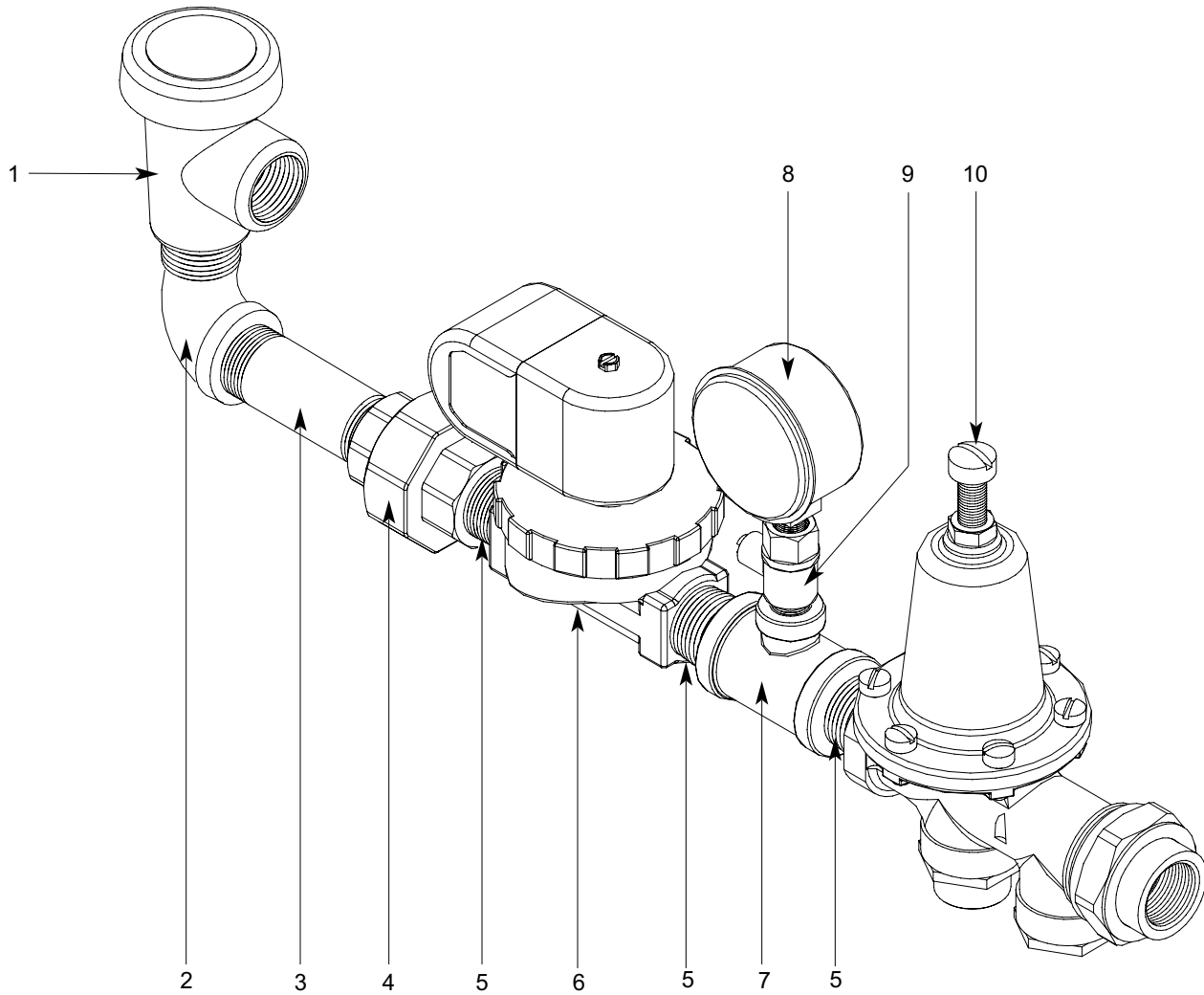

ITEM	QTY	DESCRIPTION	Mfg. No.
1	1	Vacuum Breaker, 3/4" NPT	04820-002-53-77
2	1	Elbow, Brass, Street, 3/4" NPT	04730-206-04-34
3	1	Nipple, Brass, 3/4" NPT x 3" Long	04730-011-38-29
4	1	Union, Brass, 3/4" NPT	04730-212-05-00
5	3	Nipple, Close, Brass, 3/4" NPT	04730-207-34-00
6	1	Valve, Solenoid, 3/4" NPT	04810-100-03-18
7	1	Tee, Brass, 3/4" NPT x 3/4" NPT x 1/4" NPT	04730-211-04-00
8	1	Pressure Gauge, 0-100 PSI	06685-111-59-66
9	1	Valve, Ball, Bronze, 1/4" NPT	04810-011-72-67
10	1	Water Pressure Regulator, 3/4" NPT	06685-011-58-22

SECTION 5: PARTS SECTION
TEMPSTAR SDS INCOMING PLUMBING ASSEMBLY

Please refer to page 41, for component numbers 7 through 14 to connect to the Booster Tank. Refer to page 43 for the Outlet Plumbing Assembly.

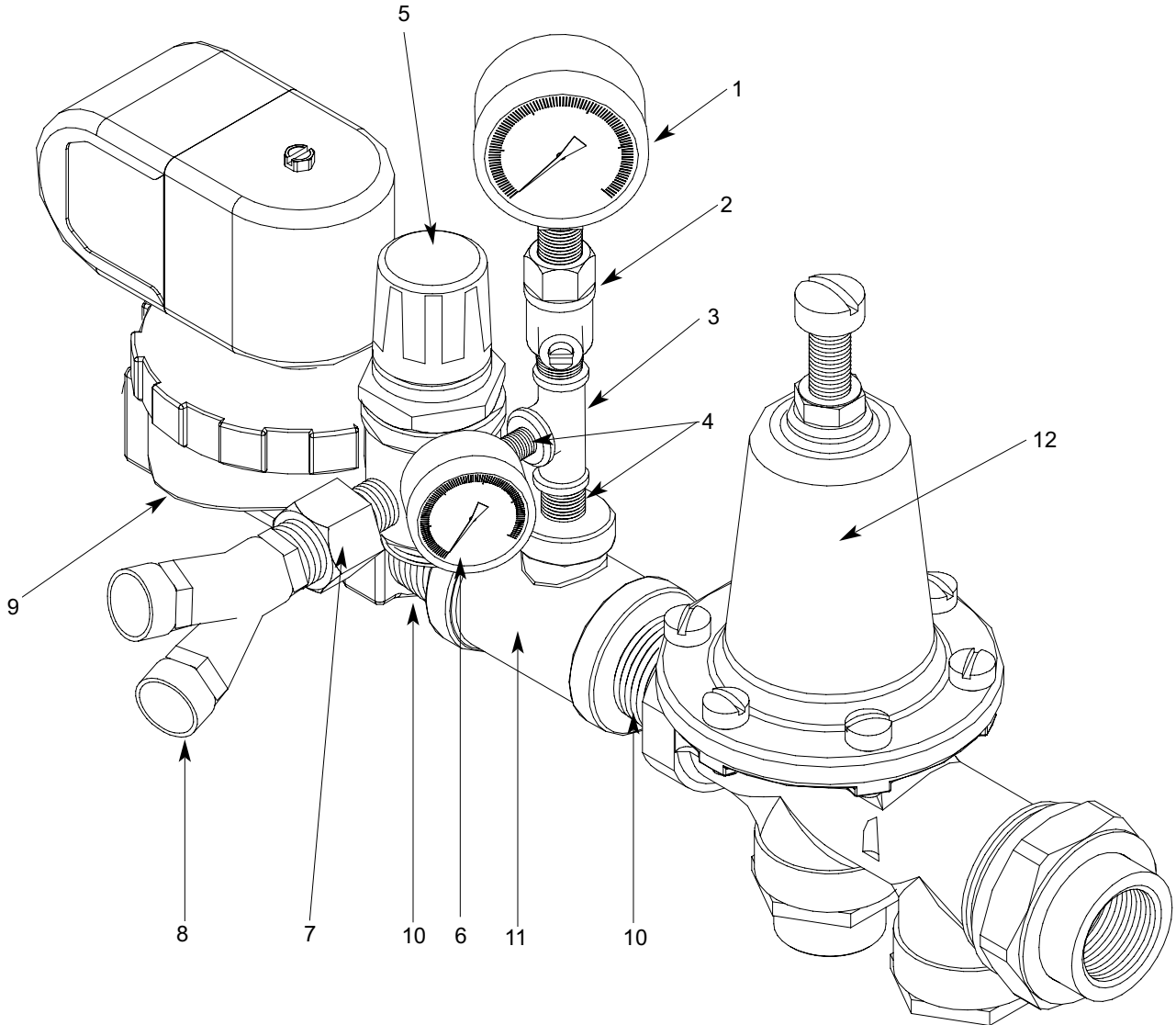

ITEM	QTY	DESCRIPTION	Mfg. No.
1	1	Gauge, Pressure, 0-100 PSI	06685-111-88-34
2	1	Valve, Ball, 1/4" NPT	04810-011-72-67
3	1	Tee, 1/4" x 1/4" x 1/4" Brass	04730-011-51-20
4	2	Nipple, 1/4" Close Brass	04730-207-02-00
5	1	Regulator, Pressure	06685-111-48-54
6	1	Gauge, Pressure, 0-100 PSI 1/8"	06685-011-48-32
7	1	Reducer, 1/4" Male x 3/8" Female Brass	04730-011-59-40
8	1	Fitting, 3/8" Y-Branch	04730-111-58-21
9	1	Valve, Solenoid, 3/4" NPT	04810-100-03-18
10	2	Nipple, Close, 3/4" NPT	04730-207-34-00
11	1	Tee, Brass, 3/4" NPT x 3/4" NPT x 1/4" NPT	04730-211-04-00
12	1	Water Pressure Regulator, 3/4" NPT	06685-011-58-22

SECTION 5: PARTS SECTION

3/4" SOLENOID VALVE & 3/4" NPT VACUUM BREAKER REPAIR PARTS KITS

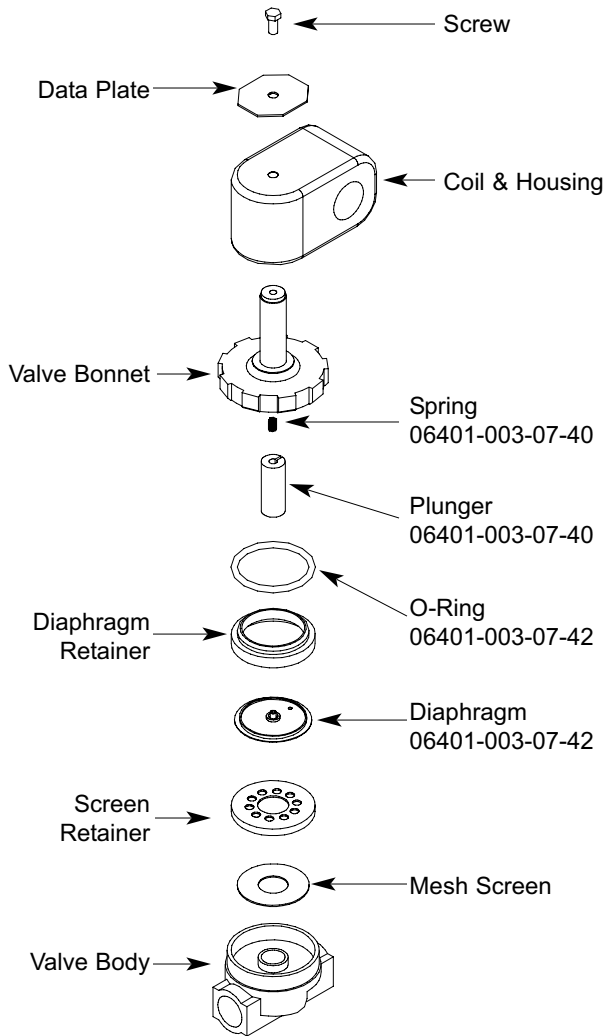

Complete 110 Volt Solenoid Valve Assembly

04810-100-53-00

Coil & Housing only

06401-003-07-43

Complete 240 Volt Solenoid Valve Assembly

04810-100-03-18

Coil & Housing only

06401-003-07-44

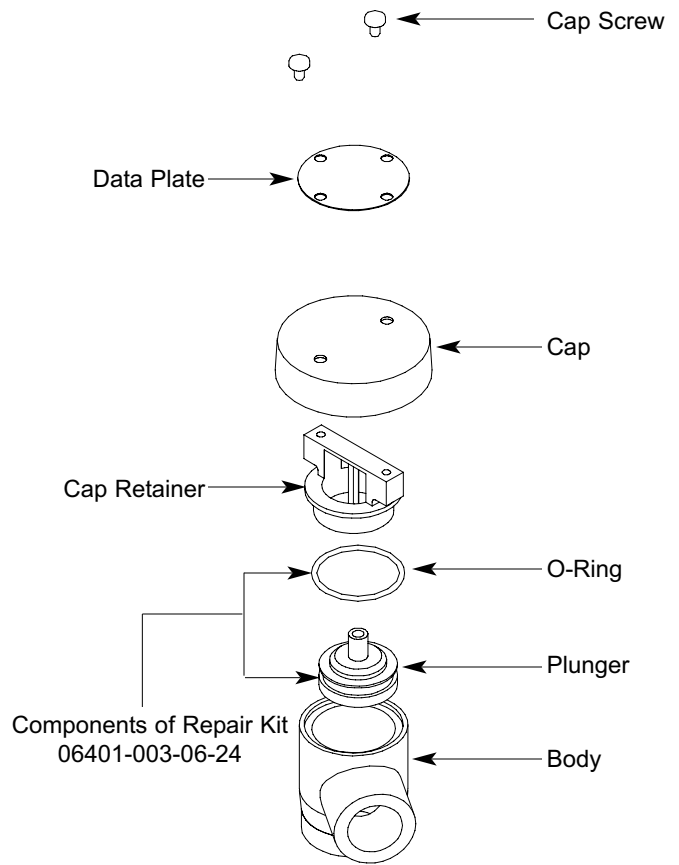

Complete Vacuum Breaker Assembly

04820-002-53-77

SECTION 5: PARTS SECTION
WASH & RINSE ARM/MANIFOLD ASSEMBLIES

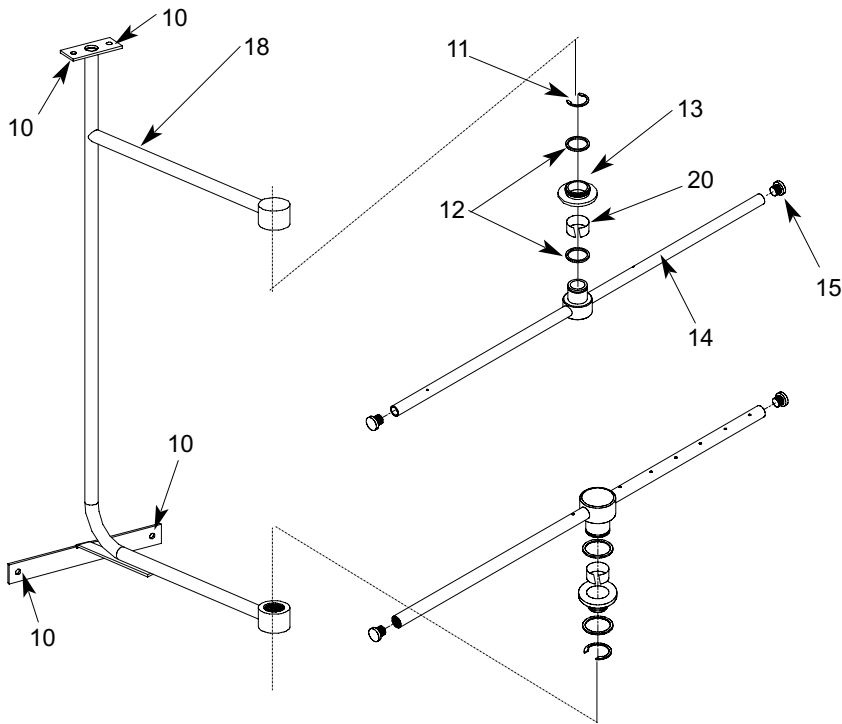

DETAIL "A"
FINAL RINSE ARMS & MANIFOLD

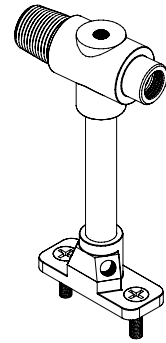

Rinse Injector Weldment
 1 per machine
 05700-021-47-65

Plug, 1/8" NPT, Brass
 3 per Rinse Injector
 04730-209-07-37

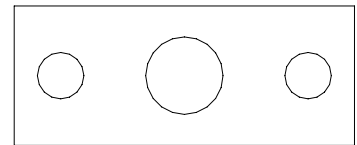

Rinse Injector Gasket
 2 per machine
 05330-111-42-81

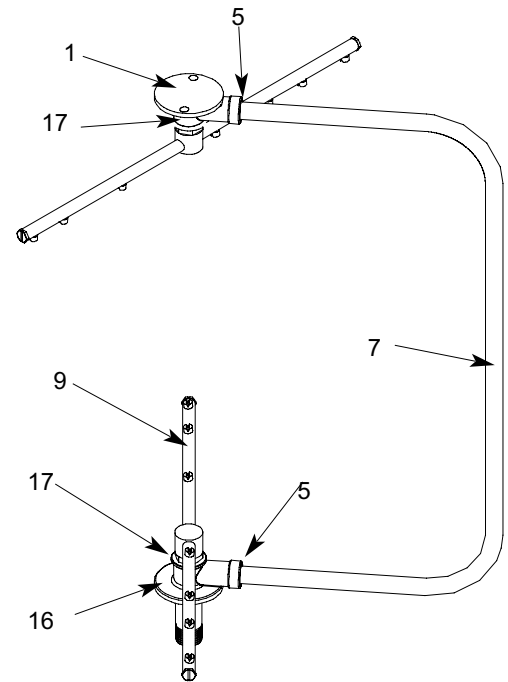
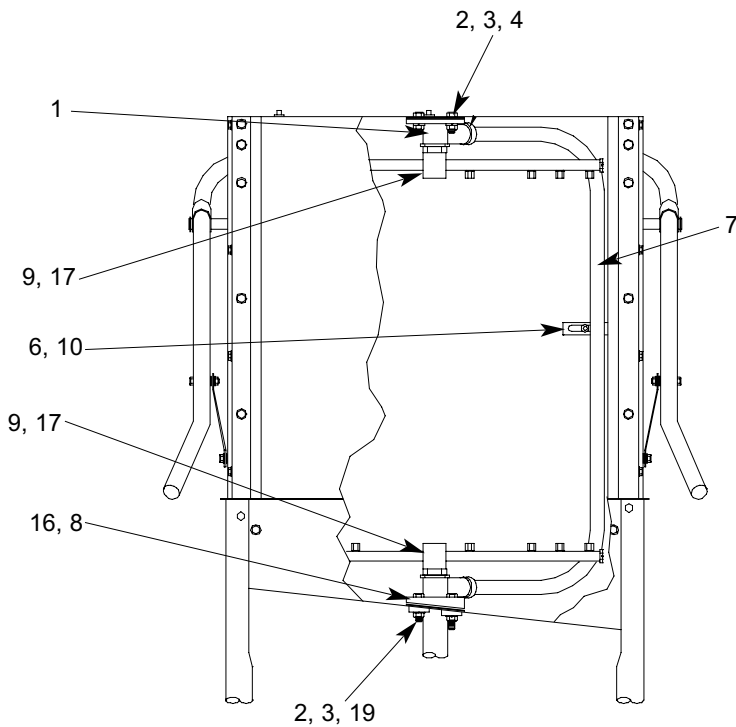

DETAIL "B"
WASH ARMS & MANIFOLD

SECTION 5: PARTS SECTION

WASH & RINSE ARM/MANIFOLD ASSEMBLIES (CONTINUED)

ITEM	QTY	DESCRIPTION	Mfg. No.
1	1	Upper Manifold	05700-031-34-82
2	4	Nut, 3/8"-16 S/S Hex	05310-276-01-00
3	4	Lockwasher, 3/8	05311-276-01-00
4	2	Bolt, Hex 3/8"-16 x 7/8" Long	05306-011-36-95
5	2	O Ring	05330-111-35-15
6	1	Positioning Bracket, Manifold Tube	05700-011-34-63
7	1	Tube, Wash Manifold	05700-131-15-07
8	2	Gasket, Manifold	05700-111-35-03
9	2	Wash Arm	05700-021-35-93
10	5	Locknut, 1/4"-20 S/S Hex with Nylon Insert	05310-374-01-00
11	2	Clip, Retaining, Rinse Head Bushing	05340-112-01-11
12	4	Rinse Arm Washer	05330-011-42-10
13	2	Bushing, Rinse Head	05700-021-33-84
14	2	Rinse Arm	05700-031-49-58
15	4	Plug, Rinse Arm	04730-609-04-00
16	1	Lower Wash Manifold	05700-031-46-00
17	2	Bearing Assembly	05700-021-35-97
17a	1	Hub Nut	05700-011-35-94
17b	1	Hub Bushing	05700-011-35-96
17c	1	Hub Spindle	05700-011-35-95
17d	1	Ring, Retainer	05340-011-37-81
17e	15	3/16" Stainless Steel Ball	03120-100-02-00
17f	20	1/8" Stainless Steel Ball	03120-011-37-82
18	1	Rinse Manifold Assembly	05700-021-47-61
19	2	Bolt, Hex 3/8"-16 x 1 1/4" Long	05305-276-10-00
20	2	Bearing, Rinse Head	03120-002-72-24

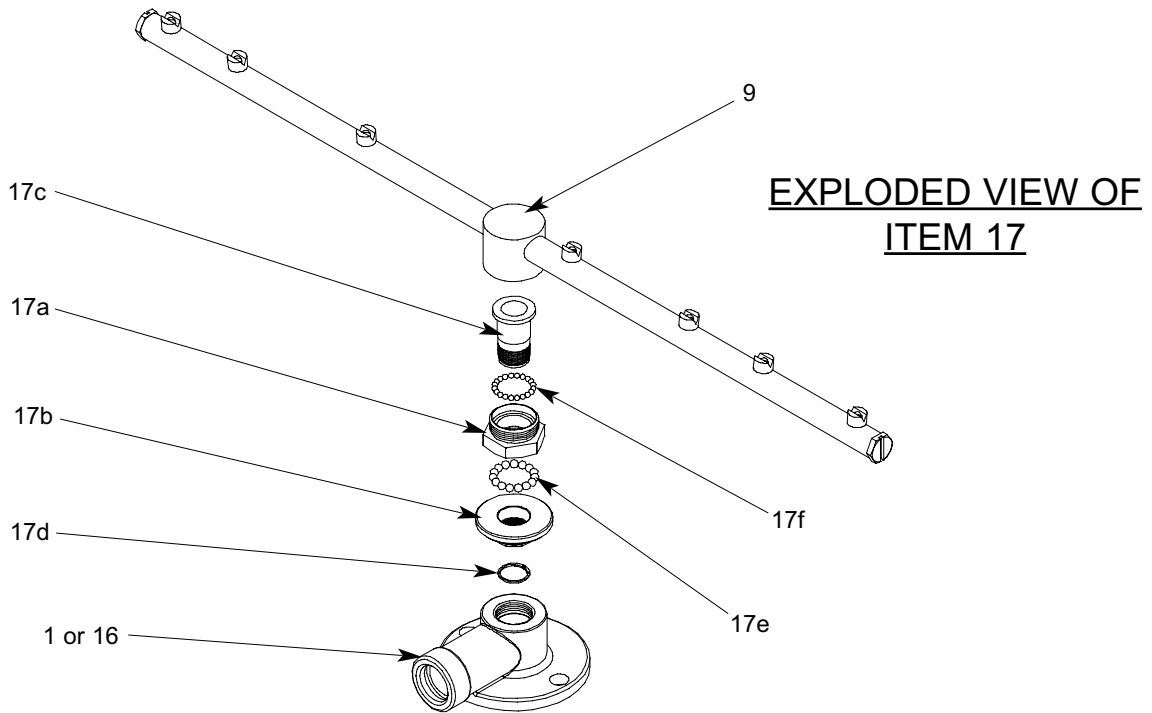

SECTION 5: PARTS SECTION
TEMPSTAR SDS DISPENSER ASSEMBLY

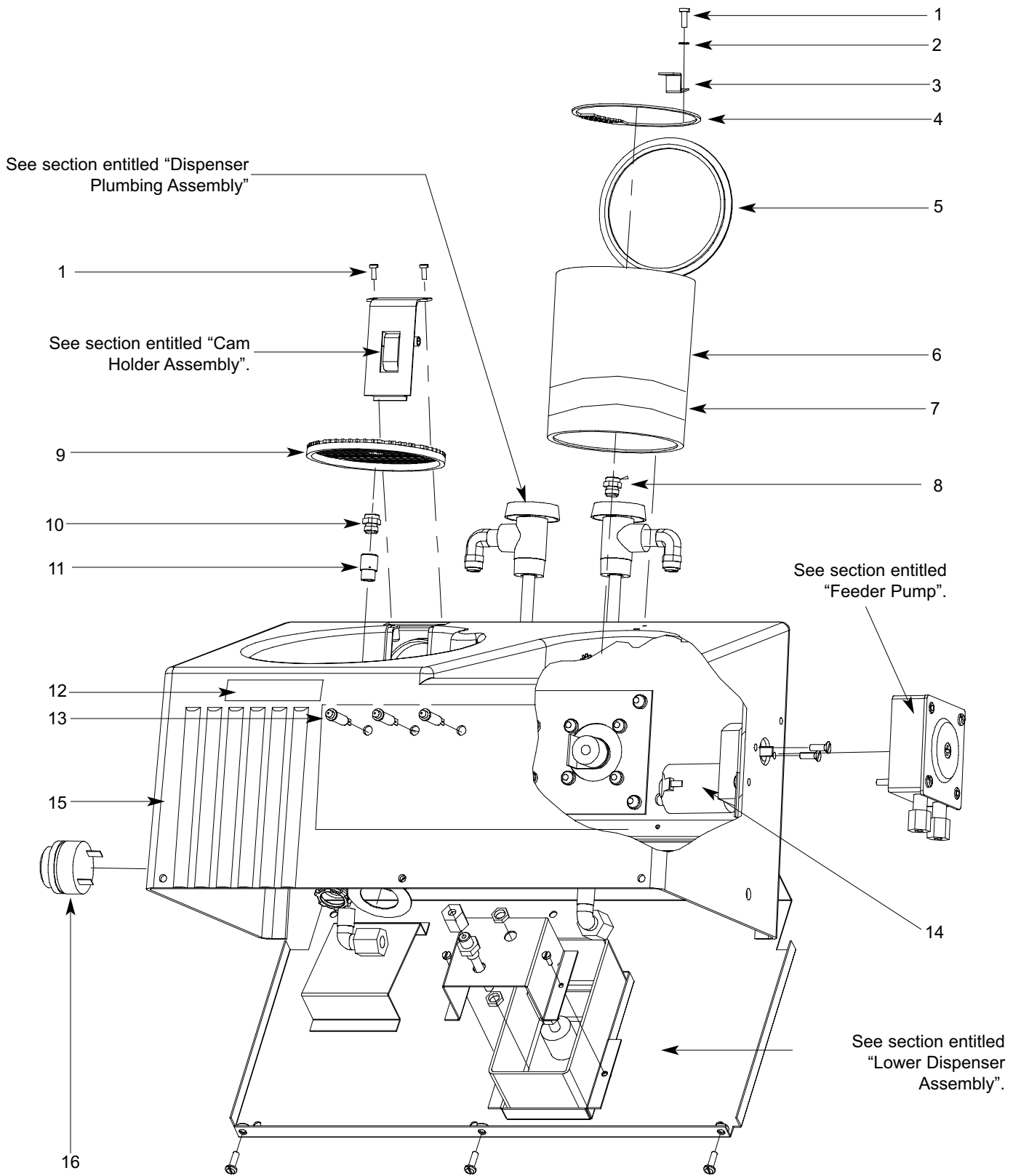

SECTION 5: PARTS SECTION
TEMPSTAR SDS DISPENSER ASSEMBLY (CONTINUED)

ITEM	QTY	DESCRIPTION	Mfg. No.
1	3	Screw, 6-32 x 3/4" Long	05305-171-07-00
2	1	Lockwasher, #6, External Tooth	05311-271-02-00
3	1	Rinse Cylinder Bracket	05700-011-59-72
4	1	Rinse Additive Screen	05930-011-48-66
5	1	Rinse Cylinder Cover	09515-011-49-01
6	1	Rinse Additive Cylinder	09515-031-49-00
7	1	Decal, Rinse Additive	09905-011-59-80
8	1	Rinse Aid Nozzle	04730-011-50-03
9	1	Detergent Screen	05335-011-48-65
10	1	Detergent Spray Nozzle	04730-011-50-04
11	1	Detergent Flush Pipe	05700-011-51-52
12	1	Decal, Detergent Additive	09905-011-59-79
13	3	Light, Red	05945-011-48-96
14	1	Motor, Feeder Pump	06105-111-51-02
15	1	Dispenser Molding	09515-031-48-62
16	1	Sonaalert	05945-011-48-97

CAM HOLDER ASSEMBLY

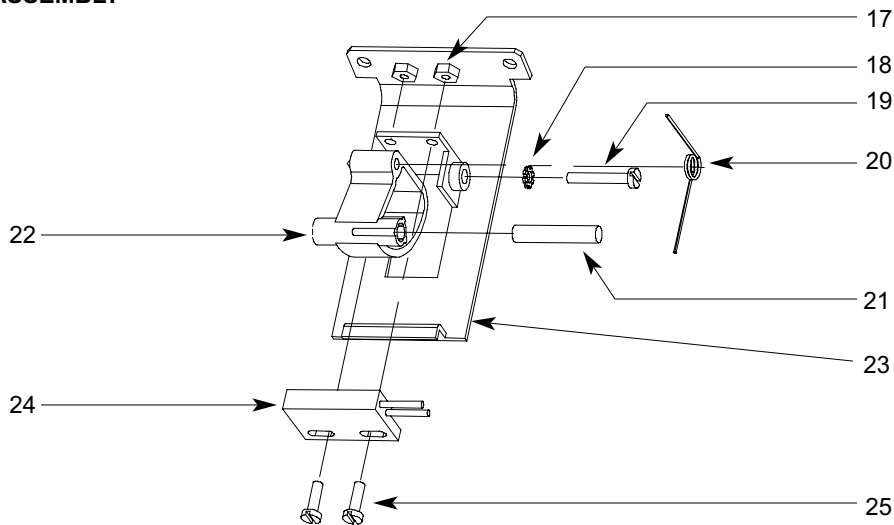

ITEM	QTY	DESCRIPTION	Mfg. No.
17	2	Locknut, 4-40	05310-279-06-00
18	1	Lockwasher, 4-40	05311-011-59-71
19	1	Screw, 4-40 x 3/4" Long	05305-011-59-64
20	1	Spring, .023 Wire	05340-111-58-02
21	1	Magnet, 3/16" x 1" Long Bar	05930-011-48-81
22	1	Holder, Cam Magnet	05340-011-48-80
23	1	Cam Holder	05340-011-59-62
24	1	Switch, 5A	05930-011-48-83
25	2	Screw, 4-40 x 3/8" Long	05305-011-59-70

SECTION 5: PARTS SECTION
TEMPSTAR SDS DISPENSER ASSEMBLY (CONTINUED)

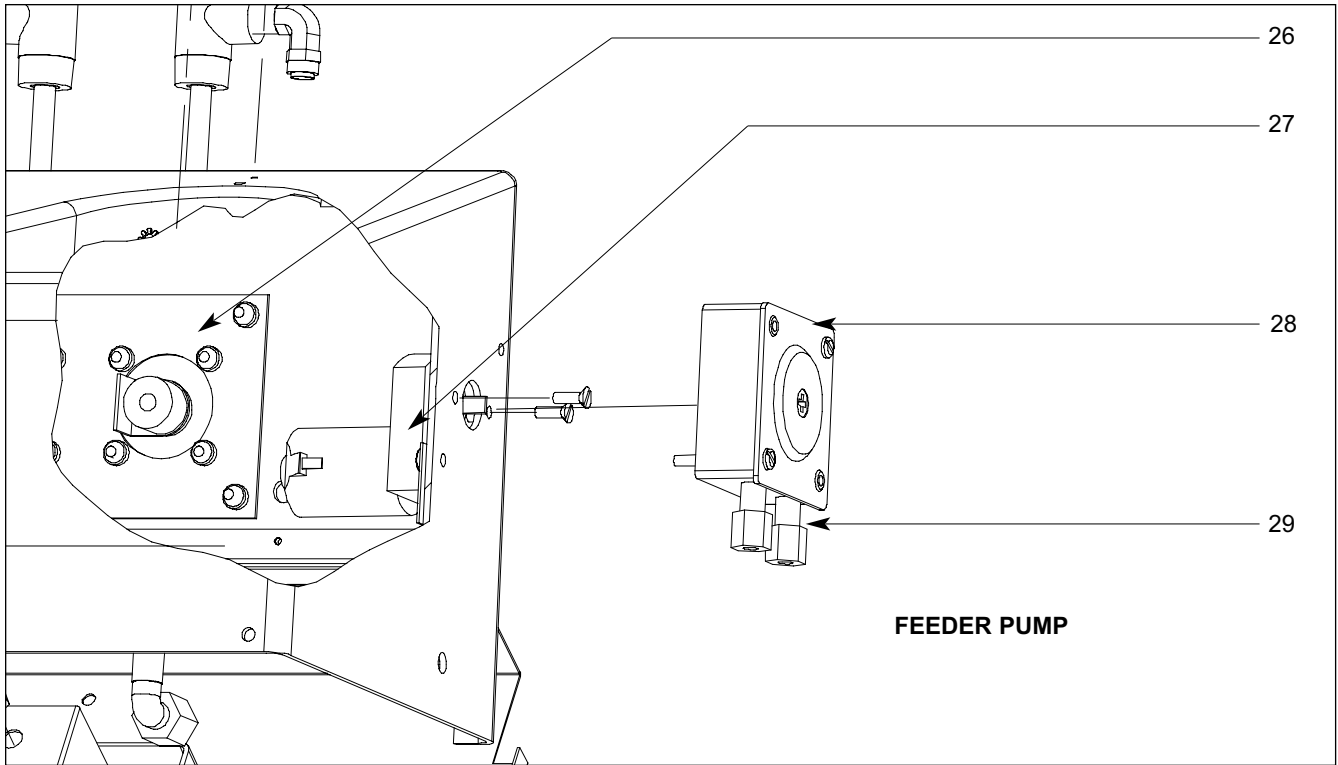

ITEM	QTY	DESCRIPTION	Mfg. No.
26	1	Plate, Solenoid Valve Mounting	05700-031-58-16
27	1	Plate, Pump Mounting	05700-011-57-88
28	1	Peristaltic Pump	04320-111-51-03
29	2	Ferrule Nut, Chemical Tube Connector	04730-609-16-00

DISPENSER PLUMBING ASSEMBLY

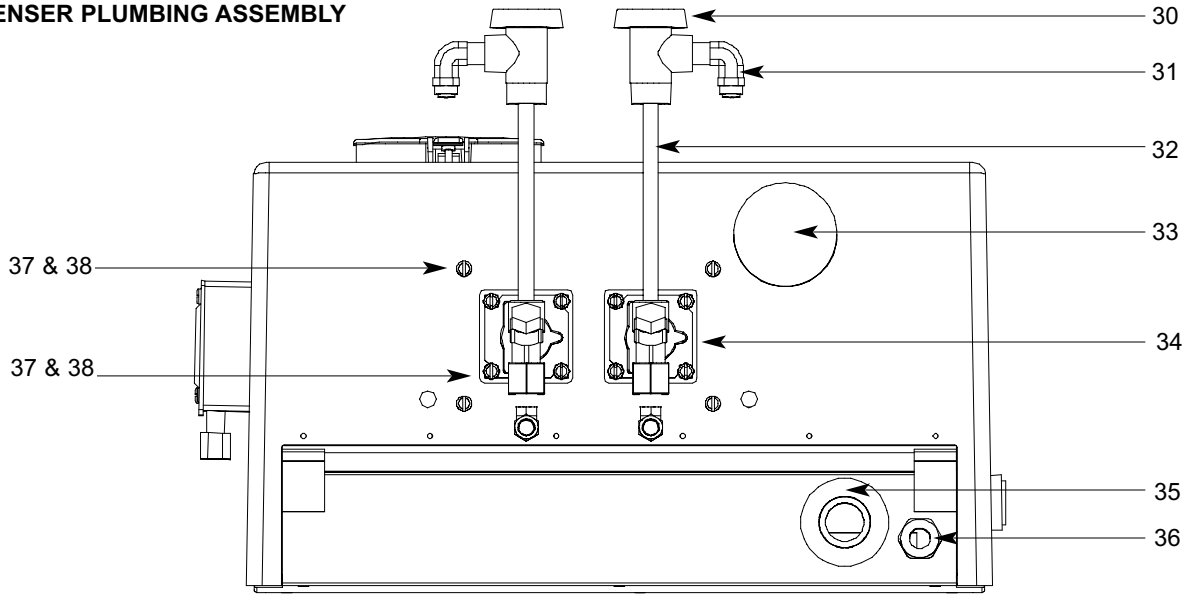

SECTION 5: PARTS SECTION

TEMPSTAR SDS DISPENSER ASSEMBLY (CONTINUED)

ITEM	QTY	DESCRIPTION	Mfg. No.
30	2	1/4" NPT Vacuum Breaker	04810-011-51-62
31	2	Elbow, 3/8" Comp. X 1/4" NPT, 90°, Brass	04730-111-58-18
32	2	Nipple, 1/4" x 6" Brass	04730-011-79-29
33	1	Plug, Hunky	05975-011-59-49
34	2	Valve, Solenoid	04810-011-48-99
35	1	Grommet, 1.25" O.D. x 1.00" I.D.	05975-111-58-01
36	1	Fitting, Liquid Tight	05975-011-49-03
37	12	Screw, 10-32 x 1/2" Long	05305-011-39-36
38	12	Lockwasher, #10 External Tooth	05311-273-03-00

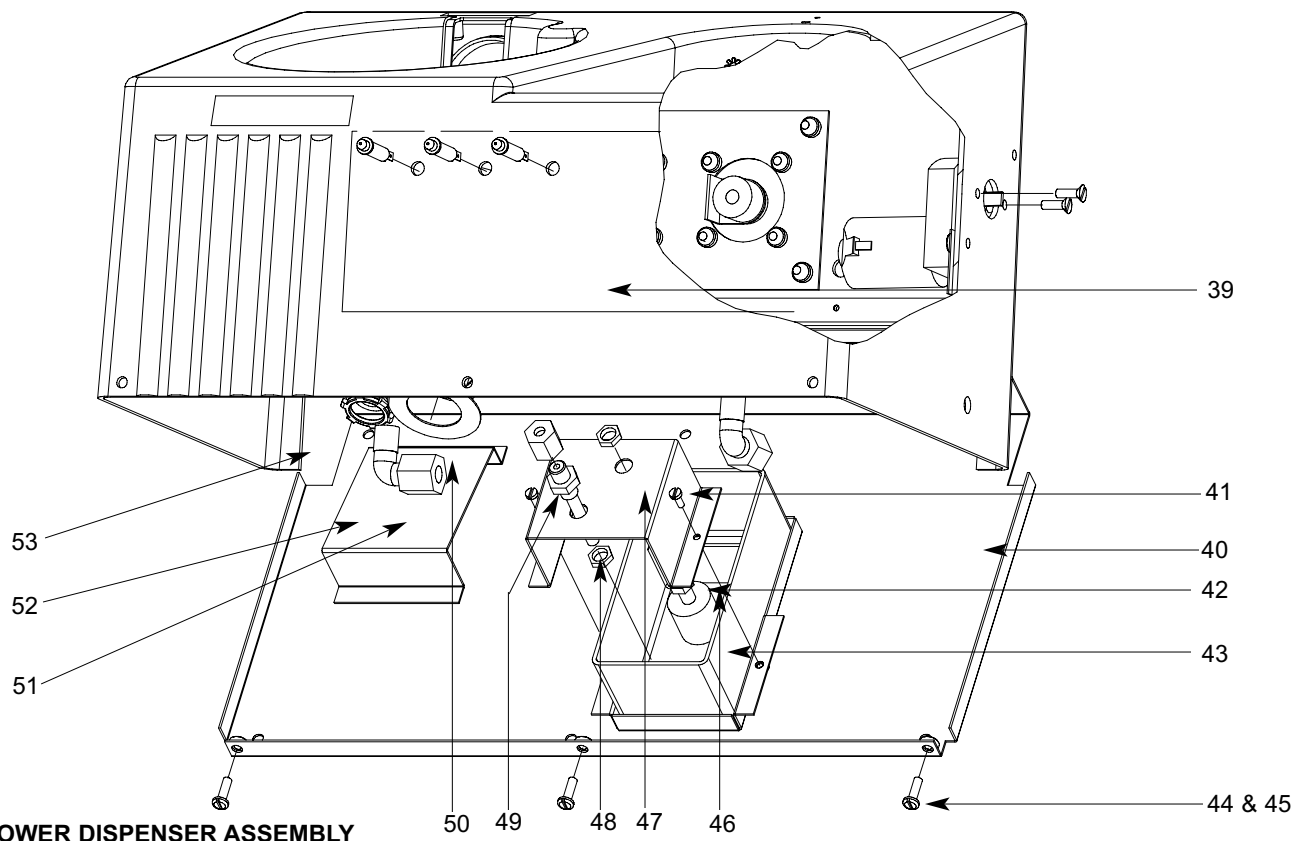

ITEM	QTY	DESCRIPTION	Mfg. No.
39	1	Decal, Dispenser Front	09905-021-50-18
40	1	Dispenser Mounting Plate	05700-031-50-12
41	2	Screw, 6-32 x 3/8" Long	05305-171-07-00
42	1	Switch, Float	05930-011-48-98
43	1	Reservoir	09515-031-48-63
44	3	Screw, 10-32 x 1/2" Long	05305-011-39-36
45	3	Lockwasher, #10 External Tooth	05311-273-03-00
46	1	Reservoir Clip	05700-021-49-26
47	1	Jam Nut, 1/8"-27	05310-011-58-00
48	1	Rinse Additive Pickup Tube	05700-011-50-14
49	1	Ferrule Nut, Chemical Tube Connector	04730-609-16-00
50	1	Panel, Dispenser Sliding Cover	05700-011-51-19
51	1	Fitting, Liquid Tight	05975-011-49-03
52	1	Elbow, 1/4" NPT x 3/8" Compression	04730-111-59-34
53	1	Insert, 3/8" Tubing P/P	04730-111-59-35

SECTION 5: PARTS SECTION
TEMPSTAR SDS DISPENSER ASSEMBLY (CONTINUED)

ITEM	QTY	DESCRIPTION	Mfg. No.
54	1	Thermal Barrier Box Assembly	05700-021-48-14
55	1	Thermal Box Top Weldment	05700-021-50-64
56	1	Thermal Box Bottom Weldment	05700-021-50-65
57	1	Foam, 1" Thick	05640-011-49-07
58	3	Screw, 10-32 x 3/8" Phillips Pan Head	05305-173-26-00
59	3	Lockwasher, #10 Internal Tooth	05311-273-03-00
60	1	Valve, Check	04820-111-51-14
61	1	Fitting, Outlet Elbow	04820-111-51-18
62	1	Nut, P/P For 1/8" Tubing	04730-011-59-45

Other components not shown:

-	-	Sensor, Detergent	06680-011-49-83
-	-	Kit, Detergent Sensor Mounting	04730-111-51-17
-	-	Gasket, 1/8" Thick	05330-021-51-08

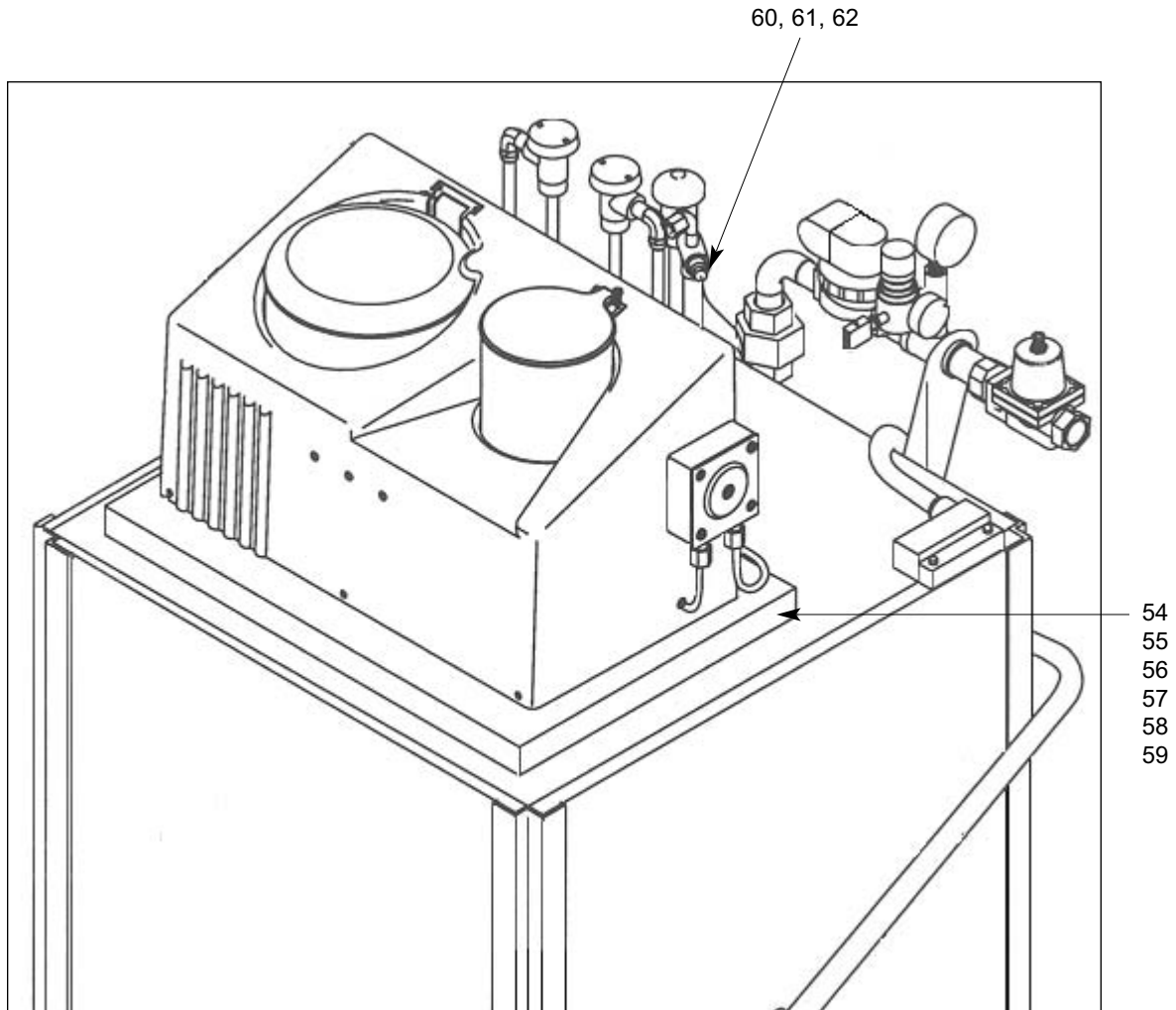

SECTION 5: PARTS SECTION

SAFETY DOOR INTERLOCK (SDI) /EXHAUST FAN CONTROL/TRANSFORMER MOUNTING BOX

Safety Door Interlock Box Bottom
05700-001-21-26

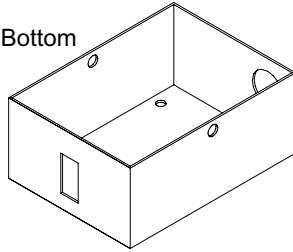

Safety Door Interlock Box Cover
05700-001-21-27

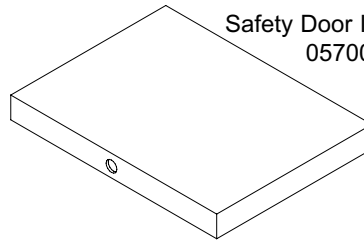

Other Safety Door Interlock (SDI) components (not shown):
DESCRIPTION

Pipe Clamp (found on the side of the machine)
Solenoid, Electrical Interlock Option
Relay

Mfg. No.

05700-000-35-05
04810-100-61-33
05945-111-47-51

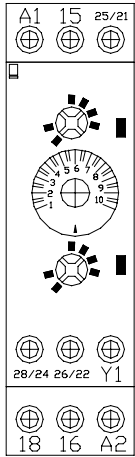

Exhaust Fan Control Delay Timer
05945-011-65-44

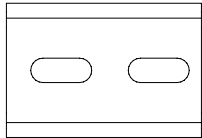

Exhaust Fan Control 2" Din Rail
05700-002-36-09

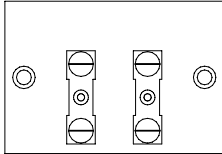

Exhaust Fan Control Terminal Board
05940-011-84-41

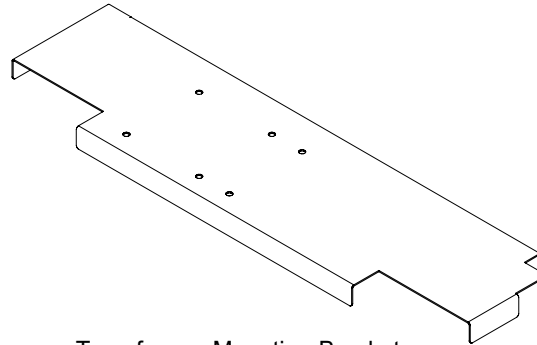

Transformer Mounting Bracket
05700-031-62-82

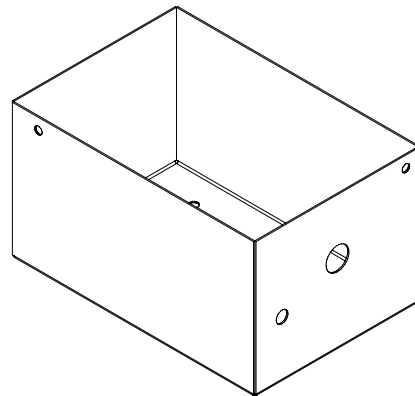

Transformer Mounting Box
05700-002-10-01

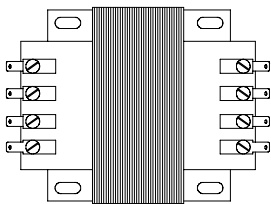

415/440/460V Transformer
05950-111-65-93

380V Transformer
05950-111-64-17

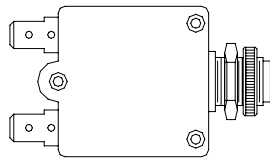

2 Amp Circuit Breaker
05925-111-64-18



Transformer Mounting Box Top (not shown)
05700-000-78-53

SECTION 5: PARTS SECTION

FALSE PANEL INSTALLATION

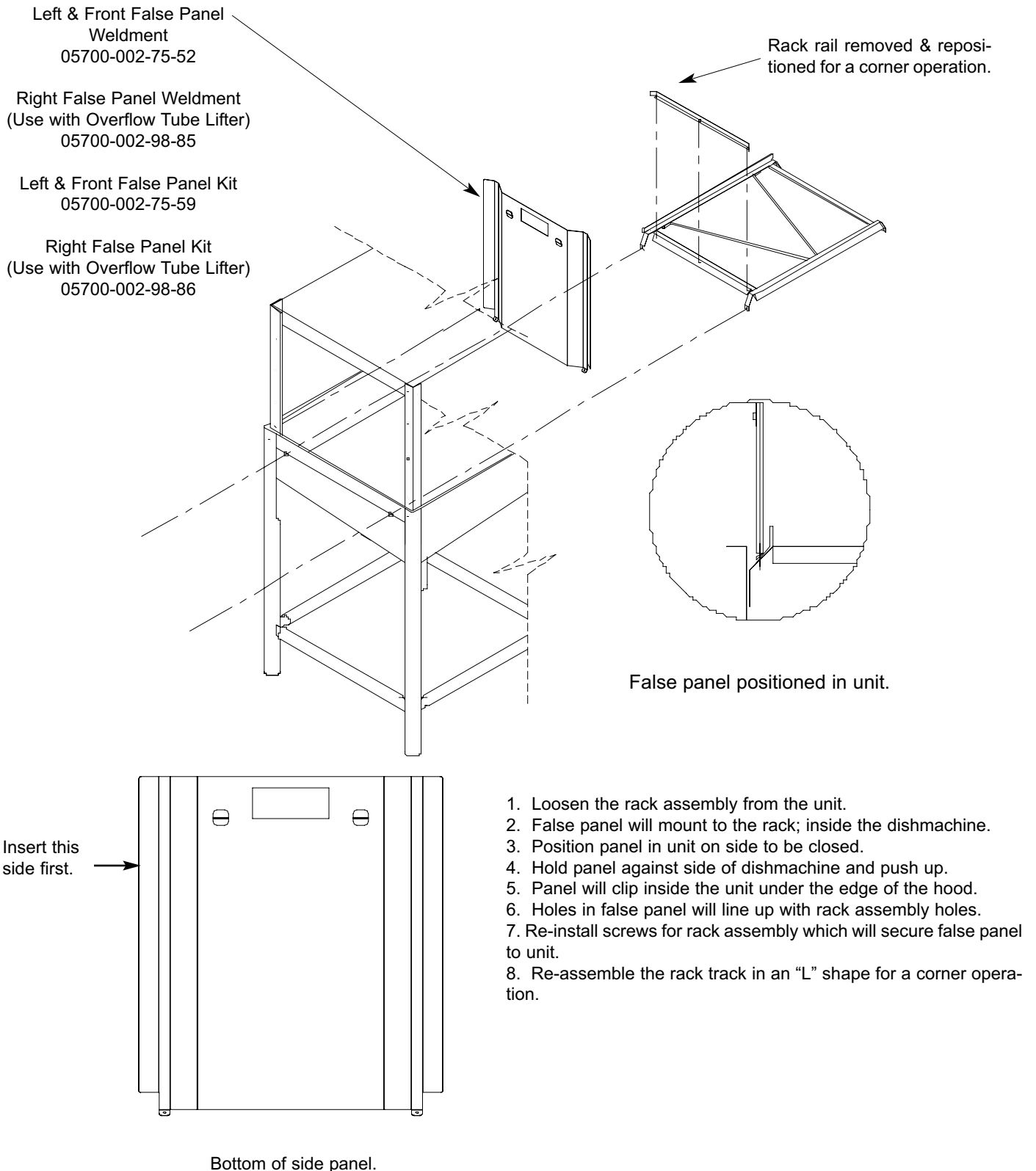

SECTION 5: PARTS SECTION

GO*BOX COMPONENTS

A GO*BOX is a kit of the most needed parts for a particular model or model family to successfully effect a repair in the first call 90% or more of the time.

The following components may be ordered together using the following Mfg. No.: 06401-002-15-00.

ITEM	QTY	DESCRIPTION	Mfg. No.
1	1	Contactora, Rinse/Wash Heater	05945-109-01-69
2	1	Contactora, Wash Motor	05945-002-74-20
3	1	Gauge, Pressure, 0-100 PSI	06685-111-88-34
4	1	Thermometer, 96" Capillary	06685-111-68-49
5	1	Thermometer, 48" Capillary	06685-111-68-48
6	1	Thermostat, Rinse Operating	06401-140-00-33
7	1	Thermostat, Wash Operating	06401-140-00-32
8	1	Thermostat, Hi-Limit	05930-011-49-43
9	1	Liquid Level Control	06680-200-08-21
10	1	Probe, water level sensing	06680-200-02-68
11	1	Magnet, Door	05930-111-51-68
12	6	Glide, Door Edge	05700-111-33-59
13	2	O-Ring Wash Manifold	05330-111-35-15
14	1	Relay, Control 240V 50/60Hz	05945-111-47-51
15	1	Seal, Mechanical Pump (S/S Pumps)	05330-002-34-22
16	1	O-Ring, Wash Pump Gasket	05330-002-81-83
17	1	Switch, Door, Magnetic Reed	05930-111-51-69
18	2	Snap Ring, Retaining, Rinse Arm	05340-112-01-11
19	1	Bearing Assembly, Wash Arm	05700-021-35-97
20	1	Switch, Power Push Button	05930-002-29-13
21	1	Timer, Universal	05945-003-33-10
22	4	Washer, Rinse Arm Nylatron	05330-011-42-10
23	1	Vacuum Breaker 3/4" Brass	04820-002-53-77
24	1	Valve, Solenoid, 3/4", 220V	04810-100-03-18
*	1	Pump & Motor Assembly, S/S Special pricing available when purchased with above GO*BOX. Call for details.	06105-002-69-78

SECTION 5: PARTS SECTION

DRAIN QUENCH ASSEMBLY

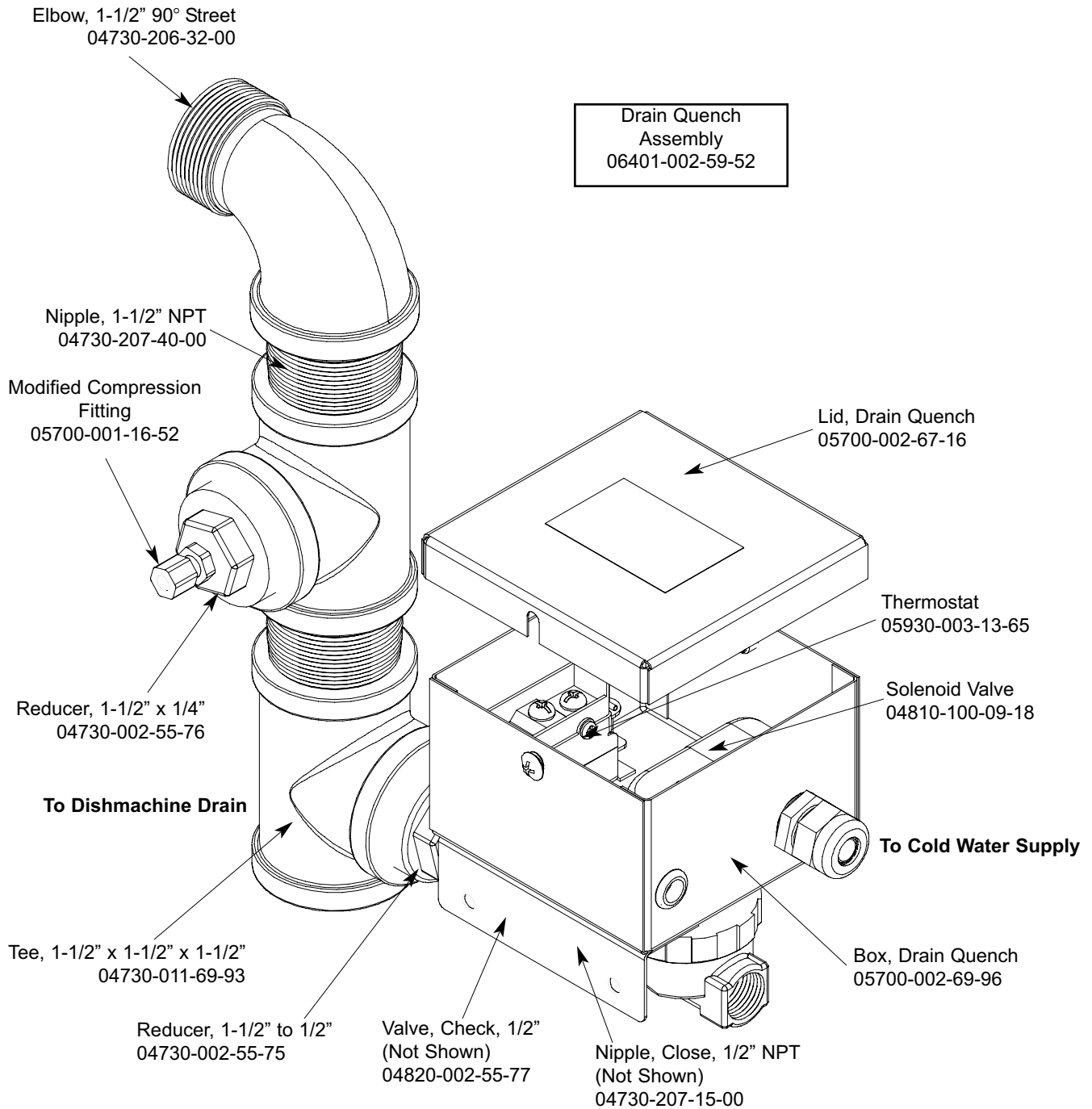

From the existing drain, attach the two additional Tees using the 1-1/2" NPT Close Nipples. Tighten the Reducers into the Tees as shown above. Attach the Modified Compression Fitting into the 1-1/2" to 1/4" Reducer. Position the bulb of the thermostat so that it rests approximately 1/4" from the bottom of the Tee. Tighten the Modified Compression Fitting as required. Attach to the incoming cold water line. Use pipe dope or thread tape as required to prevent any leaks.

**SECTION 6A:
ELECTRICAL SCHEMATICS
FOR TOP MOUNT UNITS**

SECTION 6: ELECTRICAL SCHEMATICS

TEMPSTAR (TOP MOUNT W/ CYCLE SWITCHES) 208-230 VOLT - 50/60 HERTZ - SINGLE & THREE PHASE

LEGEND

L1 L2 L3	RINSE HEATER
GND	GR'UND
H1	RINSE HEATER
H2	WASH HEATER
M1	WASH MOTOR
R1	RINSE HEATER CONTACTOR
R2	WASH HEATER CONTACTOR
R3	WASH MOTOR CONTACTOR
R4	CNTR'L RELAY
F1	CNSTANT VLTAGE C'NNECTI'N
F2	DETERGENT DISPENSER FUSE BL'CK
F3	RINSE DISPENSER FUSE BL'CK
S1	P'WER SWITCH
S2	D'IR SWITCH
S3	AUT/MANUAL (DELIME) SWITCH
S4	CYCLE SELECT'R SWITCH A
S5	CYCLE SELECT'R SWITCH B
S6	CYCLE SELECT'R SWITCH C
S7	CYCLE SELECT'R SWITCH D
E1	P'WER LIGHT
E2	HEATER OVERLOAD LIGHT
E3	CYCLE LIGHT
HLTS	WASH HEATER HIGH LIMIT THERM'STAT
TS1	RINSE HEATER THERM'STAT 1
TS2	WASH HEATER THERM'STAT
HP	HIGH WATER LEVEL PR'BE
WL	WATER LEVEL C'NTR'L
FS	RINSE/FILL S'LEN'TID
TB	TIMER BOARD

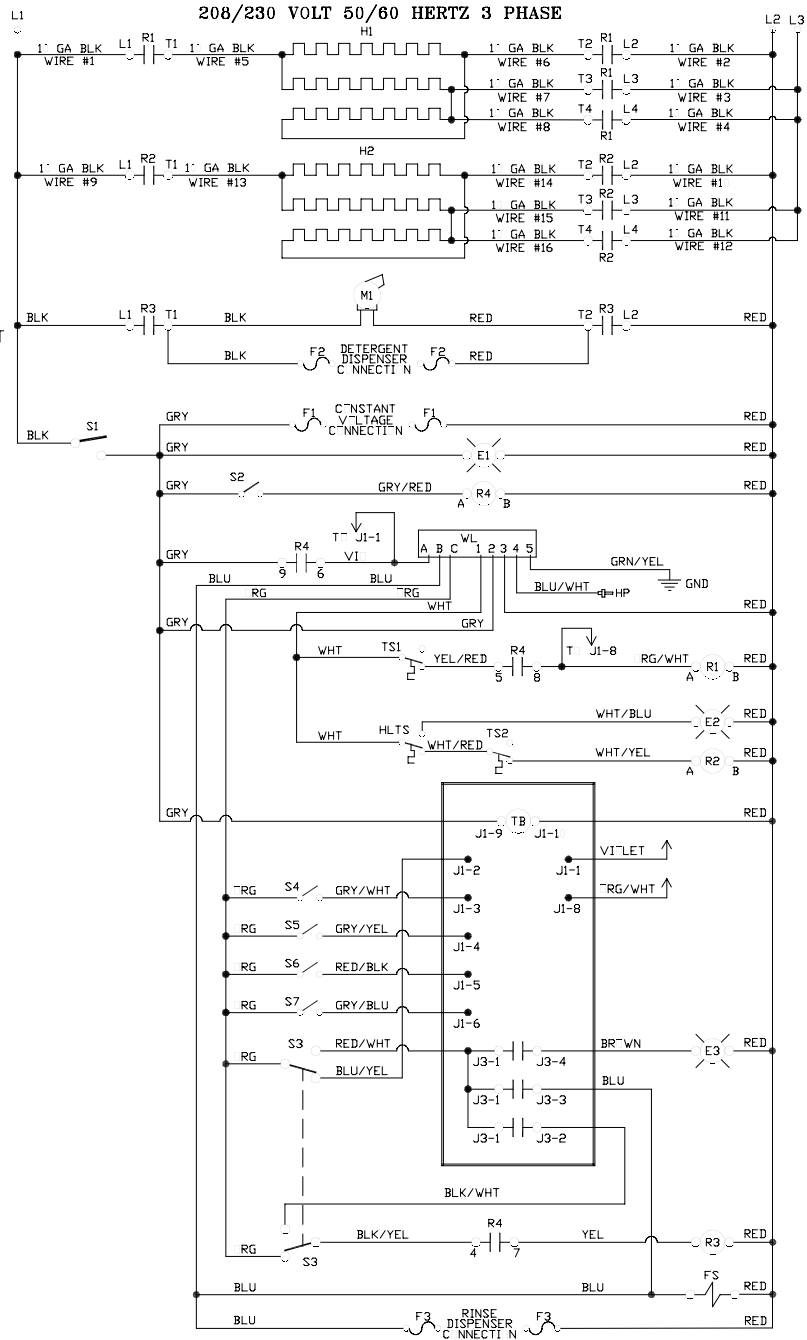
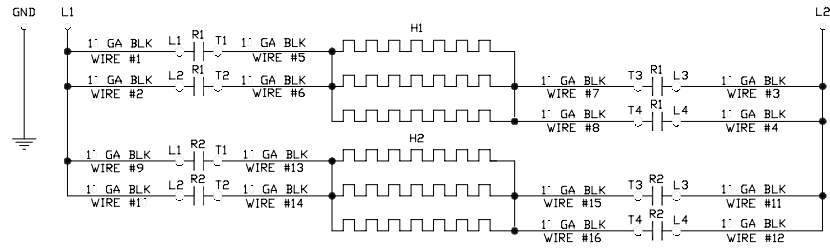

199-5-13-31-39C

SECTION 6: ELECTRICAL SCHEMATICS

TEMPSTAR (TOP MOUNT W/ CYCLE SWITCHES) 460 VOLT - 60 HERTZ -THREE PHASE

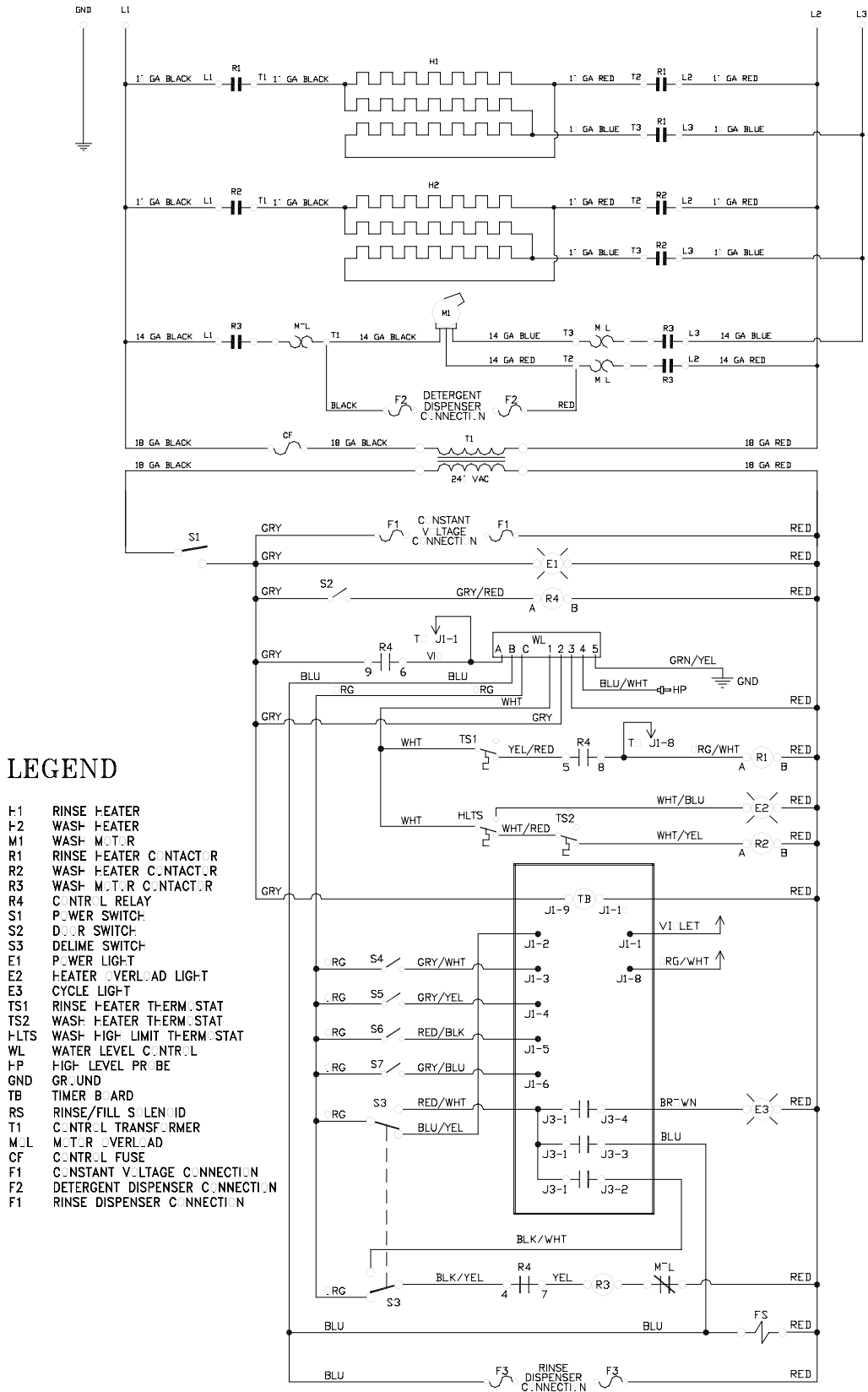

SECTION 6: ELECTRICAL SCHEMATICS

TEMPSTAR LT & NB (TOP MOUNT W/ CYCLE SWITCHES) 208-230 VOLT - 50/60 HERTZ - SINGLE & THREE PHASE

208/230 VOLT 50/60 HERTZ SINGLE PHASE

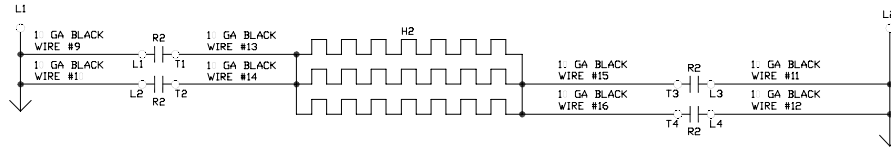

208/230 VOLT 50/60 HERTZ 3 PHASE

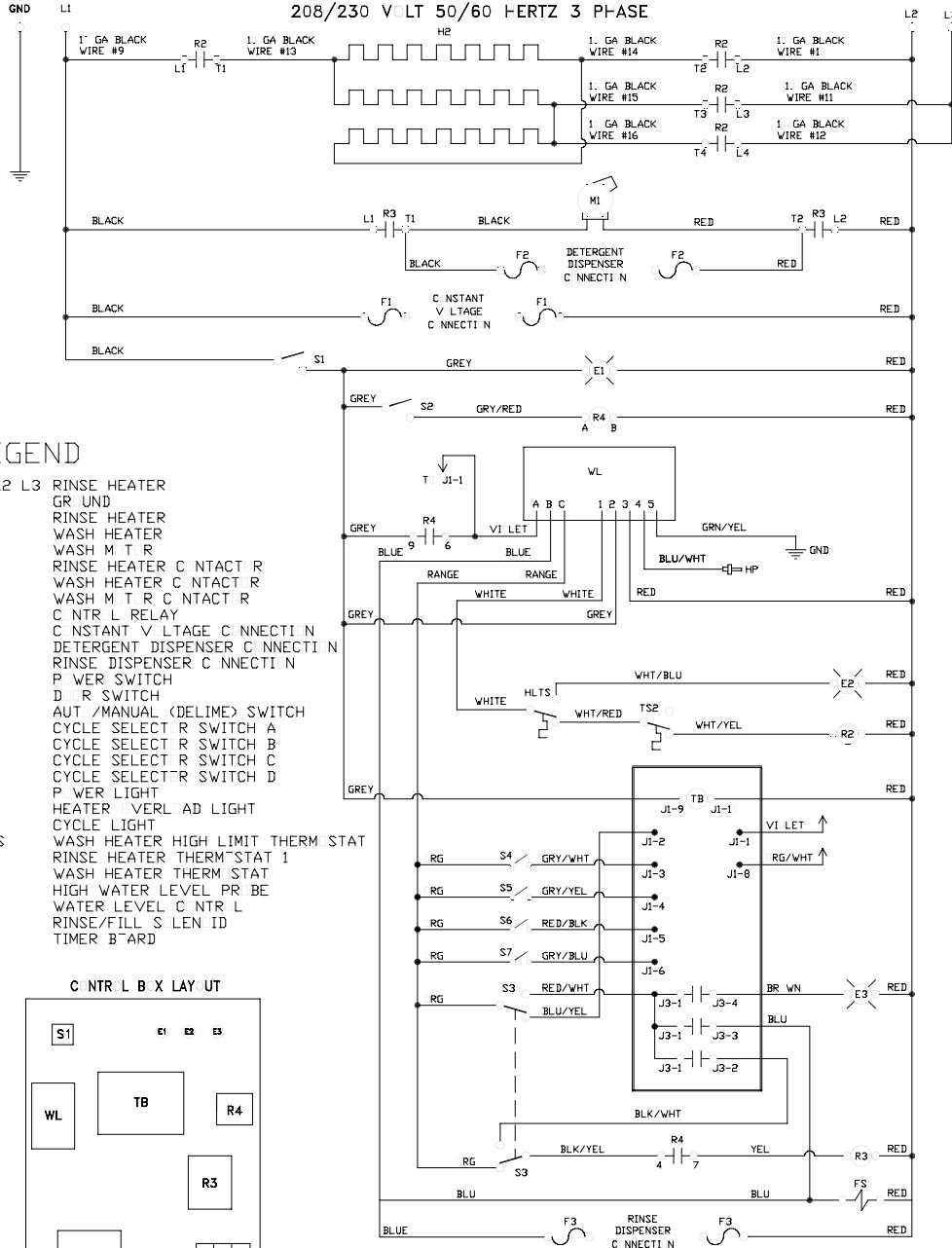

LEGEND

- L1 L2 L3 RINSE HEATER
- GND GR UND
- H1 RINSE HEATER
- H2 WASH HEATER
- M1 WASH M T R
- R1 RINSE HEATER C NTRACT R
- R2 WASH HEATER C NTRACT R
- R3 WASH M T R C NTRACT R
- R4 C NTR L RELAY
- F1 C NSTANT V LTAGE C NNECTI N
- F2 DETERGENT DISPENSER C NNECTI N
- F3 RINSE DISPENSER C NNECTI N
- S1 P WER SWITCH
- S2 D I R SWITCH
- S3 AUT /MANUAL (DELIME) SWITCH
- S4 CYCLE SELECT R SWITCH A
- S5 CYCLE SELECT R SWITCH B
- S6 CYCLE SELECT R SWITCH C
- S7 CYCLE SELECT R SWITCH D
- E1 P WER LIGHT
- E2 HEATER VERL AD LIGHT
- E3 CYCLE LIGHT
- HLTS WASH HEATER HIGH LIMIT THERM STAT
- TS1 RINSE HEATER THERM STAT 1
- TS2 WASH HEATER THERM STAT
- HP HIGH WATER LEVEL PR BE
- WL WATER LEVEL C NTR L
- FS RINSE/FILL S LEN ID
- TB TIMER B ARD

C NTR L B X LAY UT

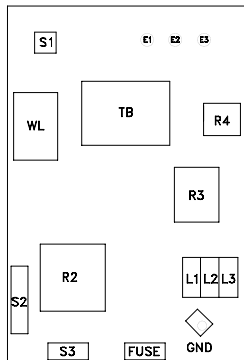

SECTION 6: ELECTRICAL SCHEMATICS

TEMPSTAR LT & NB (TOP MOUNT W/ CYCLE SWITCHES) 460 VOLT - 50/60 HERTZ - SINGLE & THREE PHASE

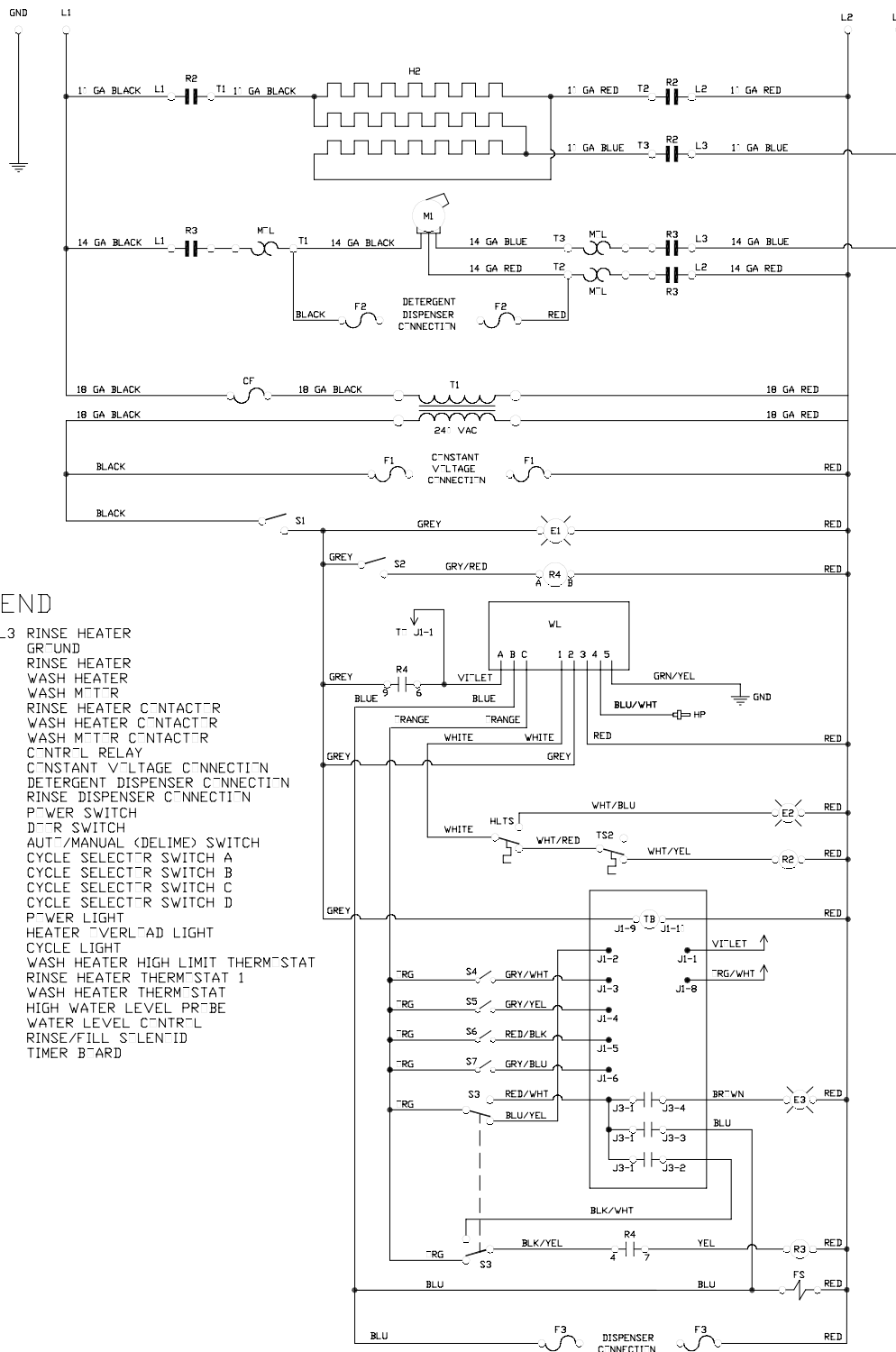

LEGEND

- L1 L2 L3 RINSE HEATER
- GND GR'UND
- H1 RINSE HEATER
- H2 WASH HEATER
- M1 WASH M'TTR
- R1 RINSE HEATER C'NTACT'R
- R2 WASH HEATER C'NTACT'R
- R3 WASH M'TTR C'NTACT'R
- R4 C'NTRL RELAY
- F1 C'NSTANT V'LTAQE C'NNECTI'N
- F2 DETERGENT DISPENSER C'NNECTI'N
- F3 RINSE DISPENSER C'NNECTI'N
- S1 P'WER SWITCH
- S2 D'OR SWITCH
- S3 AUTO/MANUAL (DELIME) SWITCH
- S4 CYCLE SELECT'R SWITCH A
- S5 CYCLE SELECT'R SWITCH B
- S6 CYCLE SELECT'R SWITCH C
- S7 CYCLE SELECT'R SWITCH D
- E1 P'WER LIGHT
- E2 HEATER 'VERLOAD LIGHT
- E3 CYCLE LIGHT
- HLTS WASH HEATER HIGH LIMIT THERM'STAT
- TS1 RINSE HEATER THERM'STAT 1
- TS2 WASH HEATER THERM'STAT
- HP HIGH WATER LEVEL PR'BE
- WL WATER LEVEL C'NTRL
- F3 RINSE/FILL SOLENOID
- TB TIMER B'ARD

SECTION 6: ELECTRICAL SCHEMATICS

TEMPSTAR (TOP MOUNT UNIVERSAL TIMER) 208-230 VOLT - 50/60 HERTZ - SINGLE & THREE PHASE

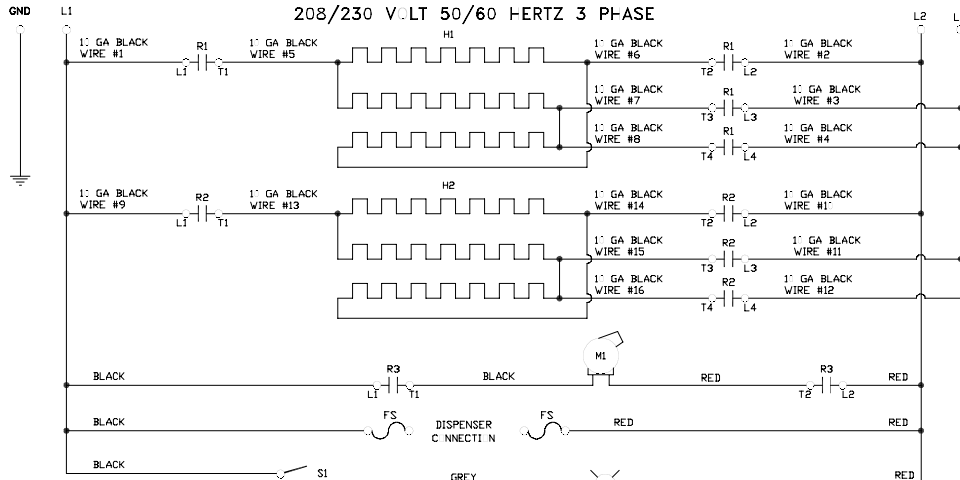
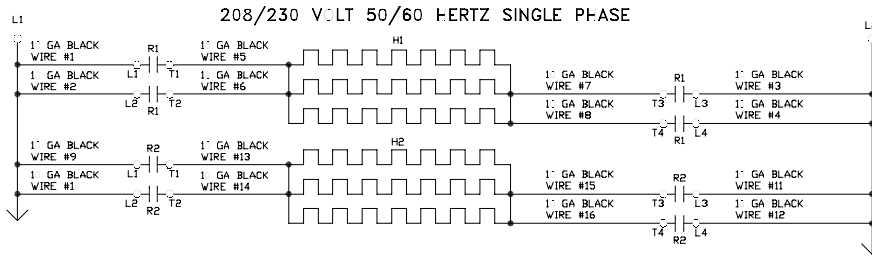

LEGEND

- | | |
|----------|-----------------------------|
| L1 L2 L3 | POWER DISTRIBUTION BLOCK |
| GND | GROUND |
| H1 | RINSE HEATER |
| H2 | WASH HEATER |
| M1 | WASH MOTOR |
| R1 | RINSE HEATER CONTACTOR |
| R2 | WASH HEATER CONTACTOR |
| R3 | WASH MOTOR CONTACTOR |
| R4 | CONTROL RELAY |
| S1 | POWER SWITCH |
| S2 | DOOR SWITCH |
| S3 | DELIME SWITCH |
| E1 | POWER LIGHT |
| E2 | HEATER OVERLOAD LIGHT |
| E3 | CYCLE LIGHT |
| TS1 | RINSE HEATER THERM. STAT |
| TS2 | WASH HEATER THERM. STAT |
| HLTS | WASH HIGH LIMIT THERM. STAT |
| WL | WATER LEVEL CONTROL |
| HP | HIGH LEVEL PROBE |
| TB | TIMER BOARD |
| RS | RINSE FILL SILEN. ID |
| FS | DISPENSER FUSE BLOCK |

CONTROL BOX LAYOUT

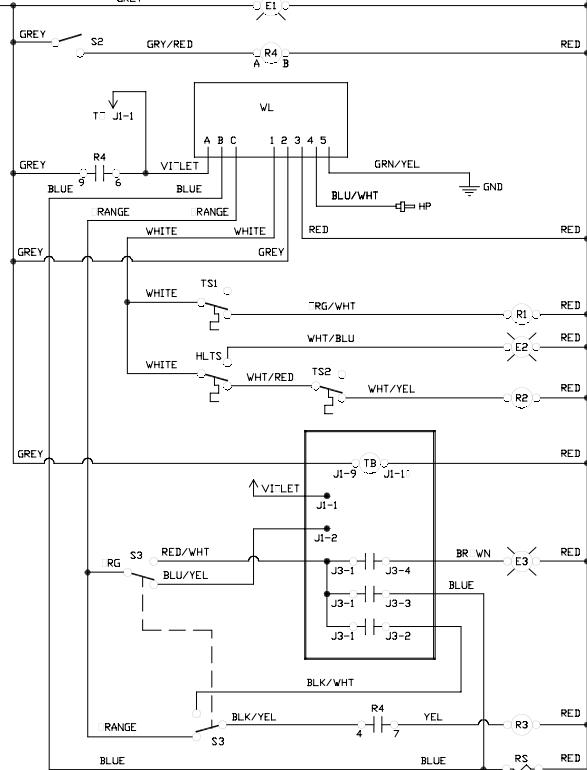
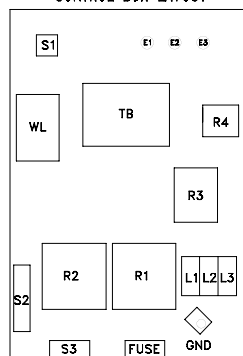

99 5- 3-14-95.

SECTION 6: ELECTRICAL SCHEMATICS

TEMPSTAR (TOP MOUNT UNIVERSAL TIMER) 380-440-460 VOLT - 50/60 HERTZ - THREE PHASE

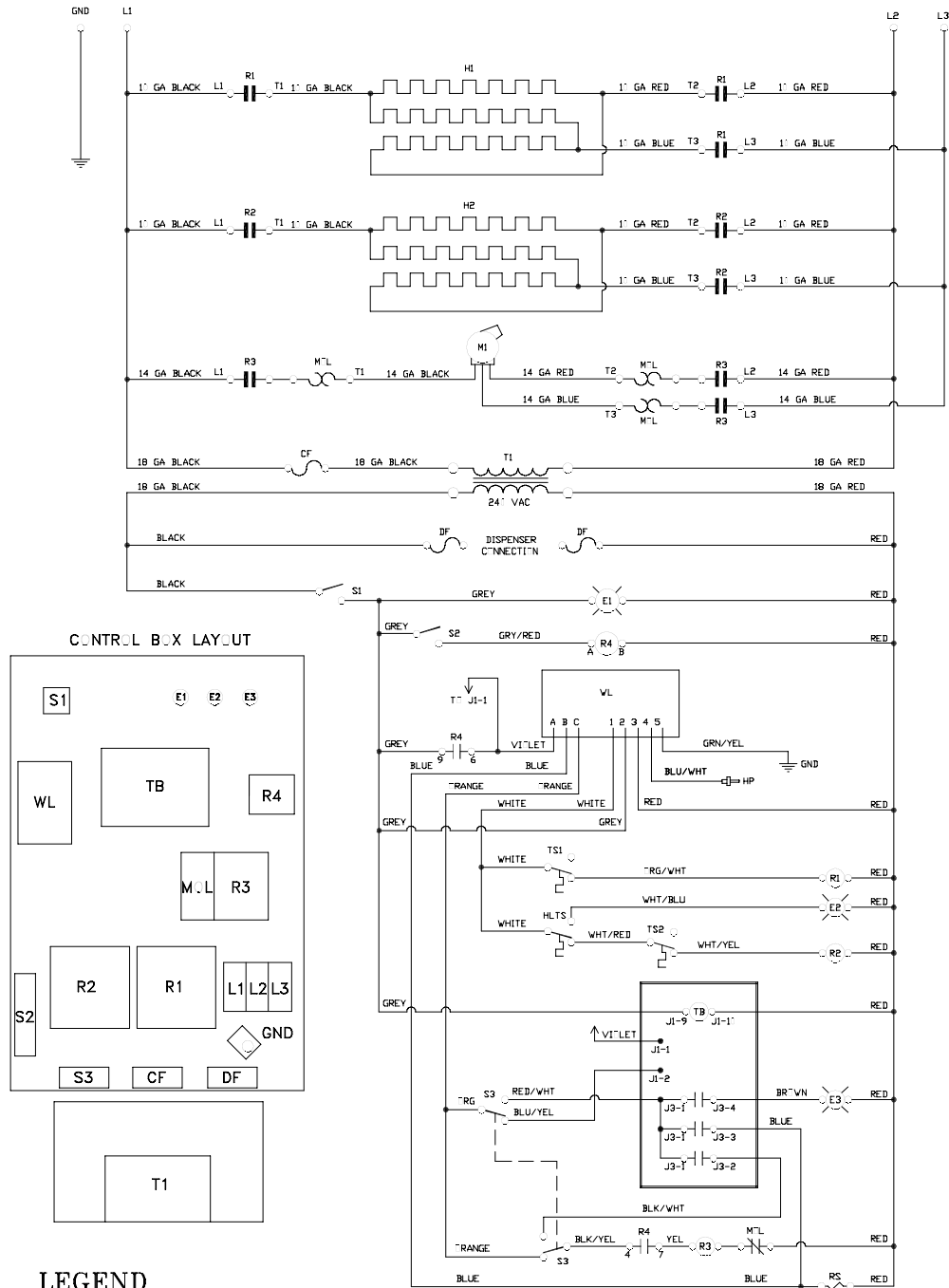

LEGEND

H-1 RINSE HEATER
 H-2 WASH. HEATER
 M1 WASH. M.T.R
 R1 RINSE HEATER C.NTACT.R
 R2 WASH. HEATER C.NTACT.R
 R3 WASH. M.T.R C.NTACT.R
 R4 C.NTR.L RELAY
 S1 P.WER SWITCH
 S2 D.R SWITCH
 S3 DELIME SWITCH

E1 P.WER LIGHT
 E2 HEATER .VERL.AD LIGHT
 E3 CYCLE LIGHT
 TS1 RINSE HEATER THERM.STAT
 TS2 WASH. HEATER THERM.STAT
 H-LTS WASH. HIGH LIMIT THERM.STAT
 WL WATER LEVEL C.NTR.L
 H-P HIGH LEVEL PR.BE
 GND GR.UND
 TB TIMER B.ARD

RS RINSE/FILL S.LEN.ID
 T1 C.NTR.L TRANSF.RMER
 M.L M.T.R .VERL.AD
 CF C.NTR.L FUSE
 DF DISPENSER FUSE BL.CK

99*5-113-14-96

SECTION 6: ELECTRICAL SCHEMATICS

TEMPSTAR LT & TEMPSTAR NB (TOP MOUNT UNIVERSAL TIMER) 208-230 VOLT - 50/60 HERTZ - SINGLE & THREE PHASE

208/230 VOLT 50/60 HERTZ SINGLE PHASE

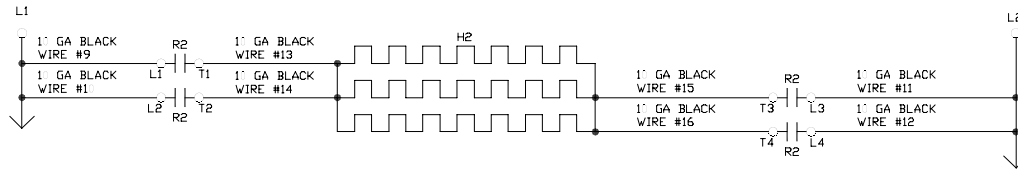

208/230 VOLT 50/60 HERTZ 3 PHASE

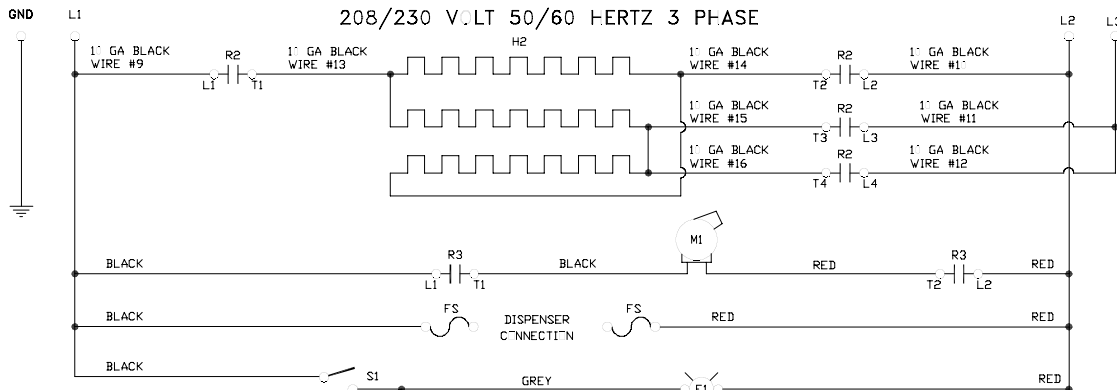

LEGEND

- | | |
|----------|-----------------------------|
| L1 L2 L3 | POWER DISTRIBUTION BLACK |
| GND | GROUND |
| H-2 | WASH HEATER |
| M1 | WASH MOTOR |
| R2 | WASH HEATER CONTACTOR |
| R3 | WASH MOTOR CONTACTOR |
| R4 | CONTROL RELAY |
| S1 | POWER SWITCH |
| S2 | DOOR SWITCH |
| S3 | DELIME SWITCH |
| E1 | POWER LIGHT |
| E2 | HEATER OVERLOAD LIGHT |
| E3 | CYCLE LIGHT |
| TS2 | WASH HEATER THERM. STAT |
| HLTS | WASH HIGH LIMIT THERM. STAT |
| WL | WATER LEVEL CONTROL |
| HP | HIGH LEVEL PROBE |
| TB | TIMER BOARD |
| RS | RINSE FILL SOLENOID |
| FS | DISPENSER FUSE BLOCK |

CONTROL BOX LAYOUT

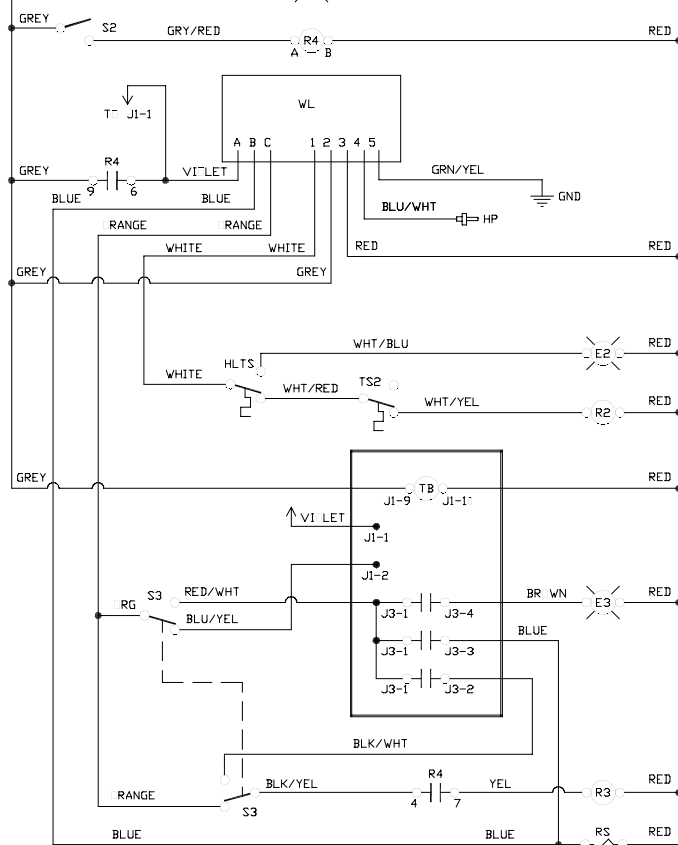
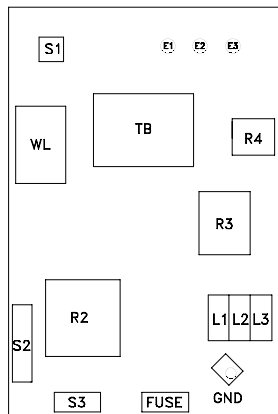

99-5-113-14-97:

SECTION 6: ELECTRICAL SCHEMATICS

TEMPSTAR LT & TEMPSTAR NB (TOP MOUNT UNIVERSAL TIMER) 380-415-440-460 VOLT - 50/60 HERTZ - THREE PHASE

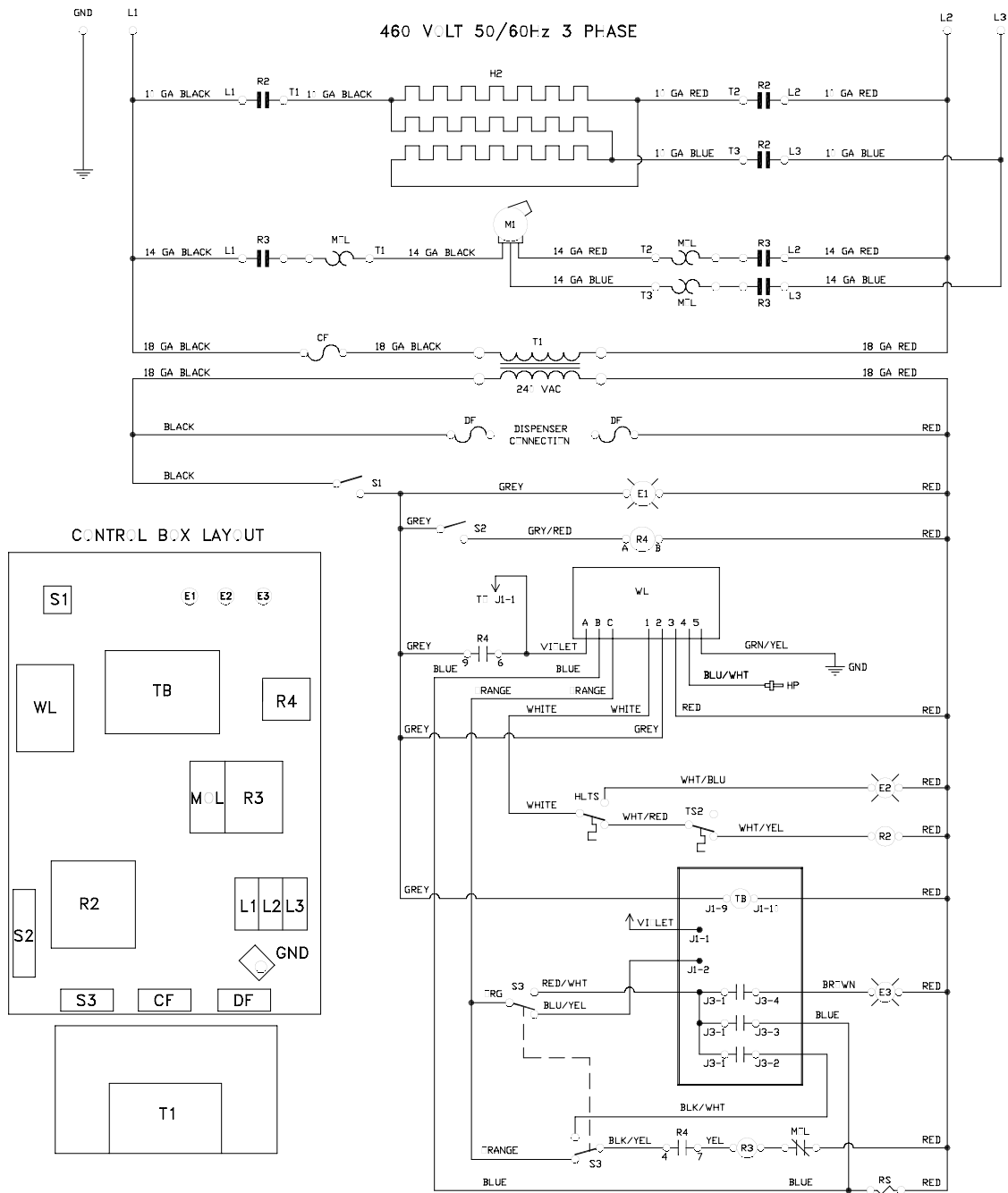

LEGEND

H2	WASH. HEATER	E1	POWER LIGHT	TB	TIMER BOARD
M1	WASH. MOTOR	E2	HEATER OVERLOAD LIGHT	RS	RINSE/FILL SOLENOID
R2	WASH. HEATER CONTACTOR	E3	CYCLE LIGHT	T1	CONTROL TRANSFORMER
R3	WASH. MOTOR CONTACTOR	TS2	WASH. HEATER THERM. STAT	M/L	MOTOR OVERLOAD
R4	CONTROL RELAY	HLTS	WASH. HIGH LIMIT THERM. STAT	CF	CONTROL FUSE
S1	POWER SWITCH	WL	WATER LEVEL CONTROL	DF	DISPENSER FUSE BLOCK
S2	DOOR SWITCH	H-P	HIGH LEVEL PROBE		
S3	DELIME SWITCH	GND	GROUND		

99-5-113-14-98

SECTION 6: ELECTRICAL SCHEMATICS

TEMPSTAR (TOP MOUNT MECHANICAL TIMER) 208-230 VOLT - 50/60 HERTZ - SINGLE & THREE PHASE

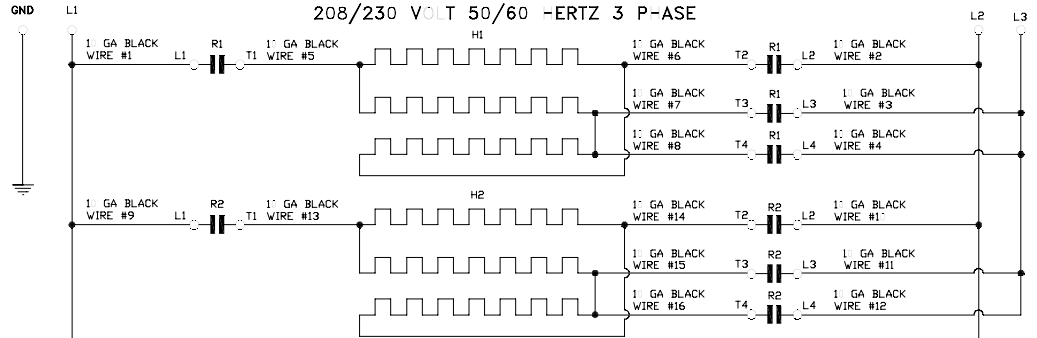
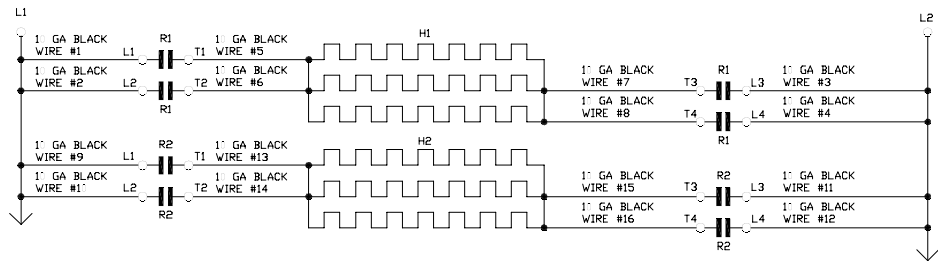

LEGEND

- | | | | |
|------|---|---|--------------------------|
| L1 | 2 | 3 | POWER DISTRIBUTION BLOCK |
| GND | | | GROUND |
| R1 | | | RINSE HEATER |
| R2 | | | WASH HEATER |
| M1 | | | WASHER MOTOR |
| R1 | | | RINSE HEATER CONTACTOR |
| R2 | | | WASH HEATER CONTACTOR |
| R3 | | | WASHER MOTOR CONTACTOR |
| R4 | | | CONTROL RELAY |
| S1 | | | POWER SWITCH |
| S2 | | | DOOR SWITCH |
| S3 | | | DETIME SWITCH |
| E1 | | | POWER LIGHT |
| E2 | | | HEATER OVERLOAD LIGHT |
| E3 | | | CYCLE LIGHT |
| TS1 | | | RINSE HEATER THERMISTAT |
| TS2 | | | WASH HEATER THERMISTAT |
| HLTS | | | WASHER LIMIT THERMISTAT |
| W | | | WATER LEVEL CONTROL |
| HP | | | WATER LEVEL PROBE |
| TM | | | TIMER MOTOR |
| C1 | | | CYCLE SWITCH |
| C2 | | | AUTO START RESET SWITCH |
| C3 | | | WASHER CYCLE SWITCH |
| C4 | | | RINSE/FILL SWITCH |
| RS | | | RINSE FILL SOLENOID |
| FS | | | DISPENSER FUSE BLOCK |

CONTROL BOX LAYOUT

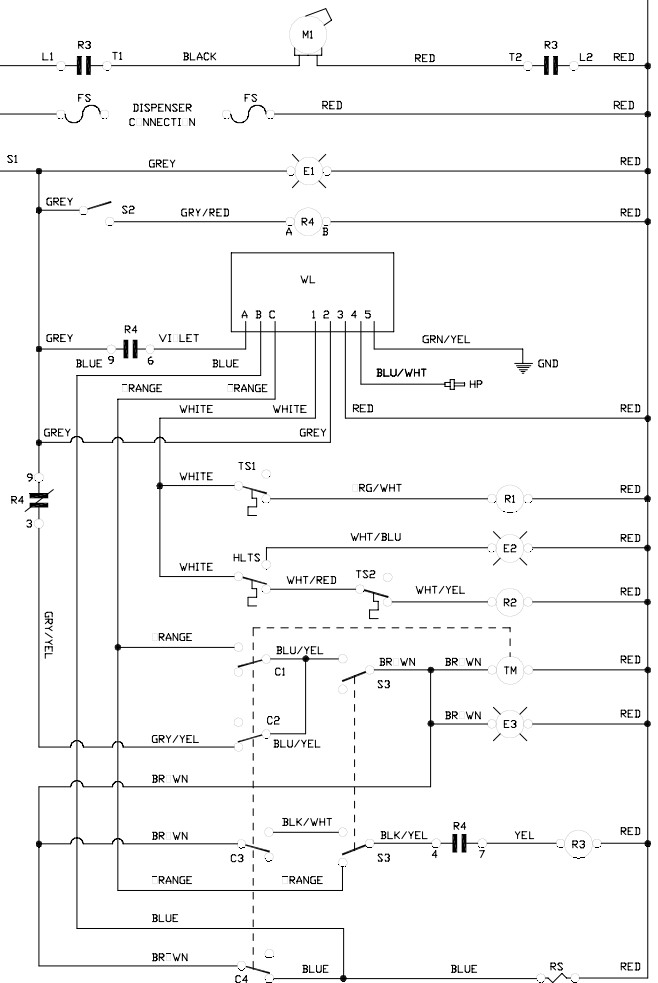
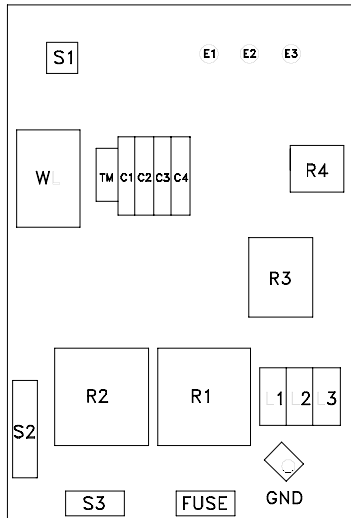

SECTION 6: ELECTRICAL SCHEMATICS

TEMPSTAR (TOP MOUNT MECHANICAL TIMER) 380-440-460 VOLT - 50/60 HERTZ - THREE PHASE

LEGEND

-L1 -L2 -L3	POWER DISTRIBUTION BLOCK
GND	GROUND
-H1	RINSE HEATER
-H2	WASH HEATER
M1	WASHER MOTOR
R1	RINSE HEATER CONTACTOR
R2	WASH HEATER CONTACTOR
R3	WASHER MOTOR CONTACTOR
R4	CONTROL RELAY
S1	POWER SWITCH
S2	DOOR SWITCH
S3	DELIME SWITCH
E1	POWER LIGHT
E2	HEATER OVERLOAD LIGHT
E3	CYCLE LIGHT
TS1	RINSE HEATER THERMISTAT
TS2	WASH HEATER THERMISTAT
-TS	WASHER THERMISTAT
W	WATER LEVEL CONTROL
-P	WASHER LEVEL PROBE
TM	TIMER MOTOR
C1	CYCLE SWITCH
C2	AUTO START RESET SWITCH
C3	WASHER CYCLE SWITCH
C4	RINSE/FILL SWITCH
RS	RINSE/FILL SENSING
M.L	MOTOR OVERLOAD
T1	CONTROL TRANSFORMER
CF	CONTROL FUSE
DF	DISPENSER FUSE BLOCK

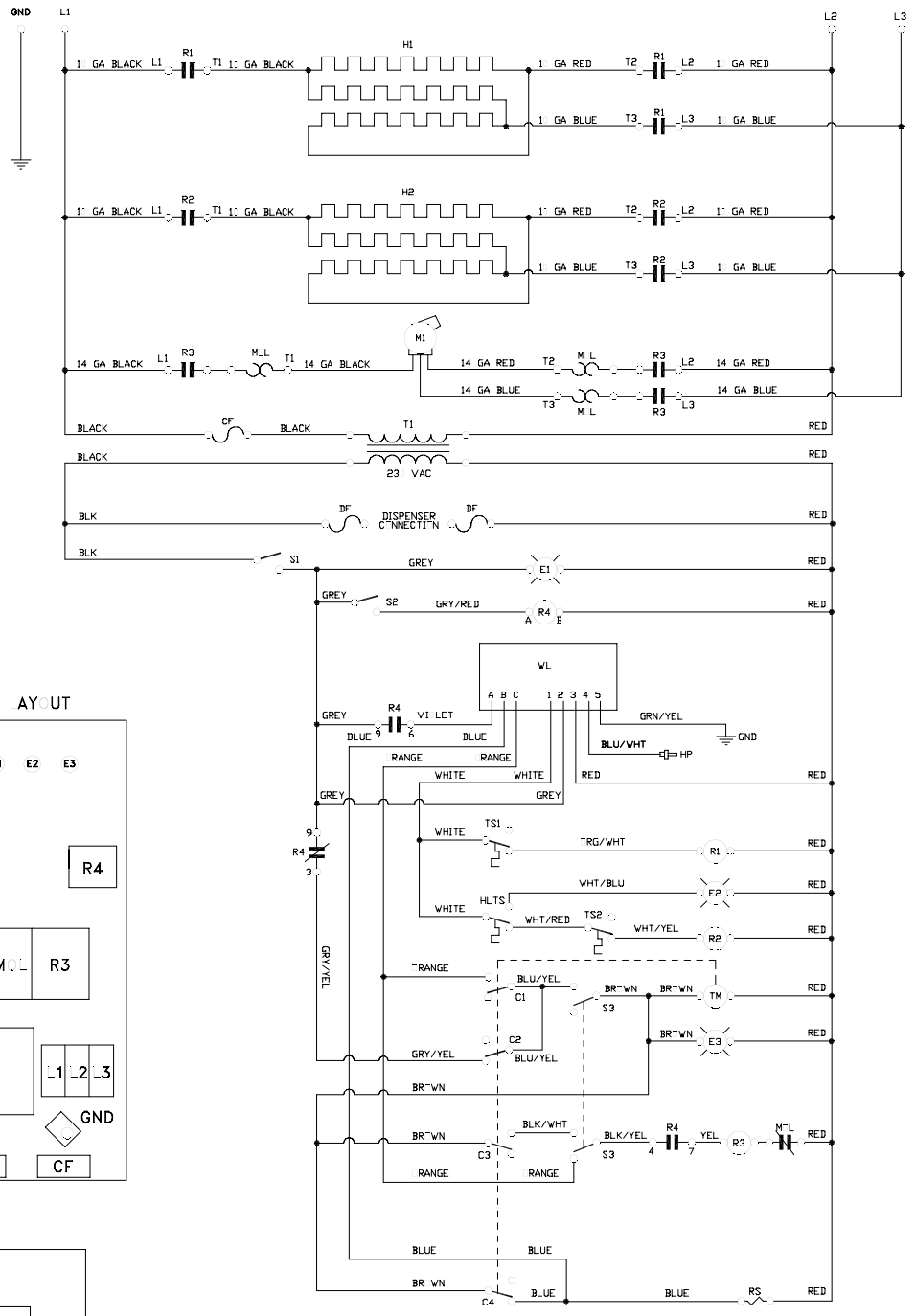

CONTROL BOX LAYOUT

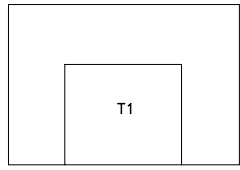
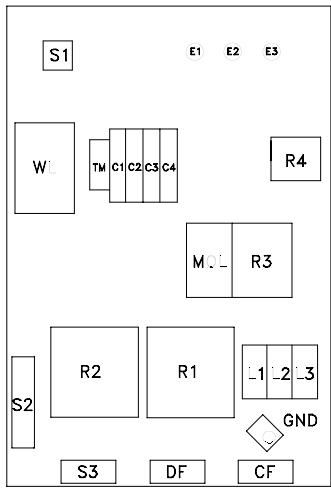

9905-002-57-72d

SECTION 6: ELECTRICAL SCHEMATICS

TEMPSTAR (TOP MOUNT MECHANICAL TIMER) 415 VOLT - 50/60 HERTZ - THREE PHASE - 5 WIRE

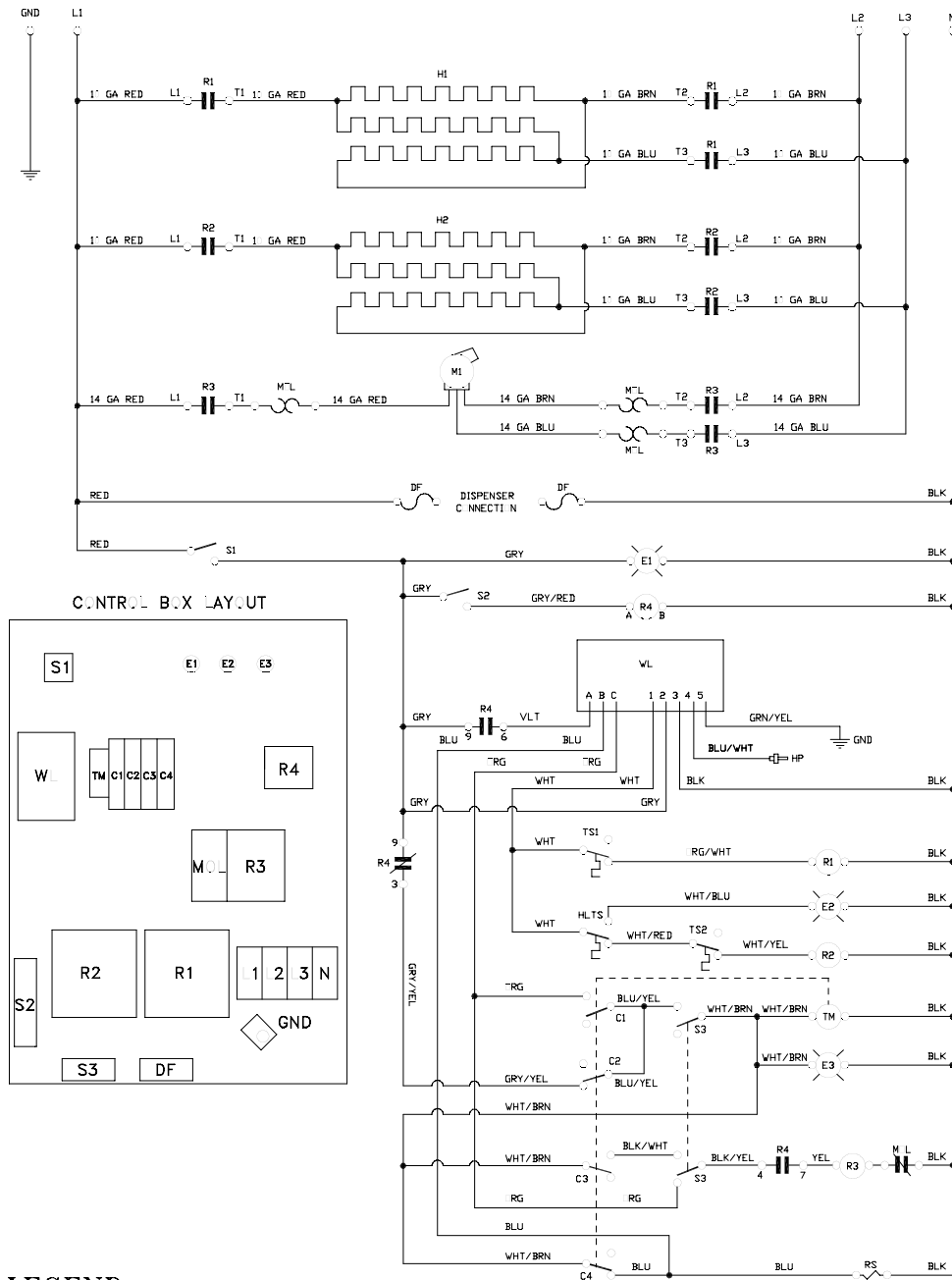

LEGEND

-1	RINSE -EATER	E1	P- WER IG-T	C1	CYC E SWITC-
-2	WAS- -EATER	E2	-EATER OVER AD IG-T	C2	AUT- START RESET SWITC-
M1	WAS- M T R	E3	CYC E IG-T	C3	WAS- CYC E SWITC-
R1	RINSE -EATER C NTRACT R	TS1	RINSE -EATER T-ERM STAT	C4	RINSE/FI S- EN ID
R2	WAS- -EATER C NTRACT R	TS2	WAS- -EATER T-ERM STAT	RS	RINSE/FI S- EN ID
R3	WAS- M T R C NTRACT R	- TS	WAS- -IG- IMIT T-ERM STAT	M	M T R VER AD
R4	C NTR- RE AY	W	WATER EVE C NTR	DF	DISPENSER FUSE B LOCK
S1	P- WER SWITC-	-P	-IG- EVE PR BE		
S2	D- R SWITC-	GND	GR- UND		
S3	DE IME SWITC-	TM	TIMER M T R		

9905-002-76-58a

SECTION 6: ELECTRICAL SCHEMATICS

TEMPSTAR LT & TEMPSTAR NB (TOP MOUNT MECHANICAL TIMER) 208-230 VOLT - 50/60 HERTZ - SINGLE & THREE PHASE

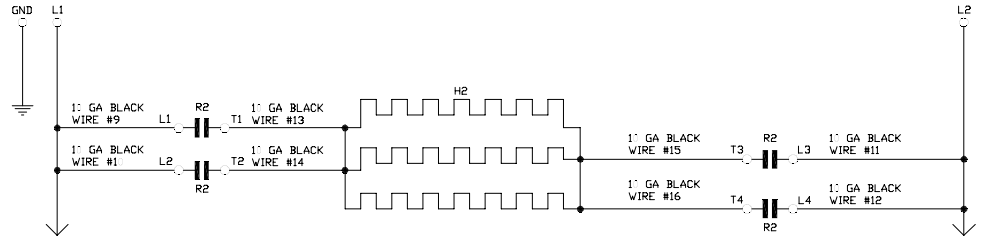

LEGEND

L1 L2 L3	POWER DISTRIBUTION BLOCK
GND	GROUND
H2	WASH HEATER
M1	WASH MOTOR
R2	WASH HEATER CONTACTOR
R3	WASH MOTOR CONTACTOR
R4	CONTROL RELAY
S1	POWER SWITCH
S2	DOOR SWITCH
S3	DELIME SWITCH
E1	POWER LIGHT
E2	HEATER OVERLOAD LIGHT
E3	CYCLE LIGHT
TS2	WASH HEATER THERMISTAT
HLTS	WASH LIGHT LIMIT THERMISTAT
WL	WATER LEVEL CONTROL
W	WATER LEVEL PROBE
TM	TIMER MOTOR
C1	CYCLE SWITCH
C2	AUTO START RESET SWITCH
C3	WASH CYCLE SWITCH
C4	RINSE/FILL SWITCH
RS	RINSE FILL SOLENOID
FS	DISPENSER FUSE BLOCK

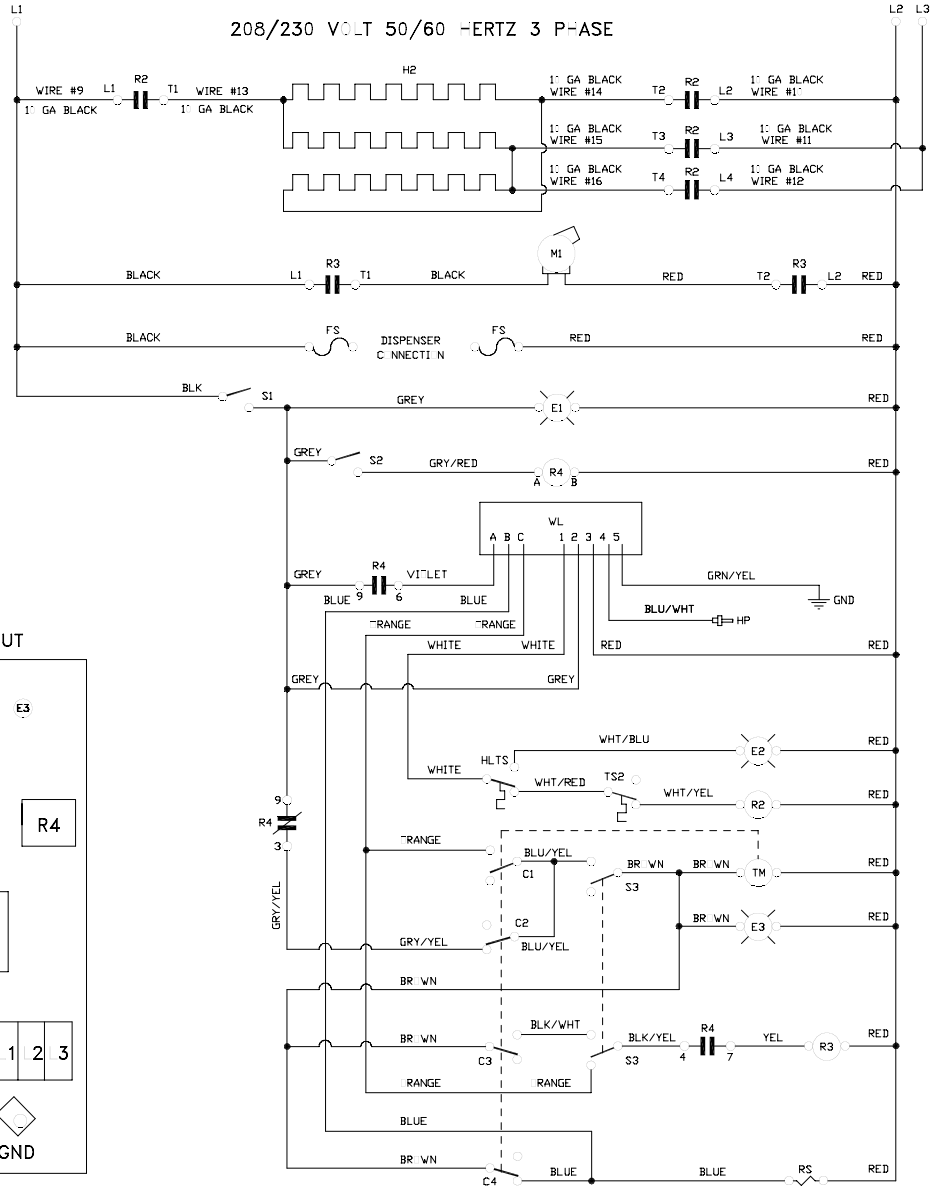

CONTROL BOX LAYOUT

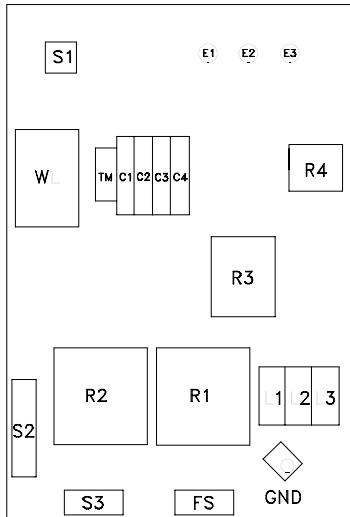

9905-002-53-70b

SECTION 6: ELECTRICAL SCHEMATICS

TEMPSTAR LT & TEMPSTAR NB (TOP MOUNT MECHANICAL TIMER) 380-415-440-460 VOLT - 50/60 HERTZ - THREE PHASE

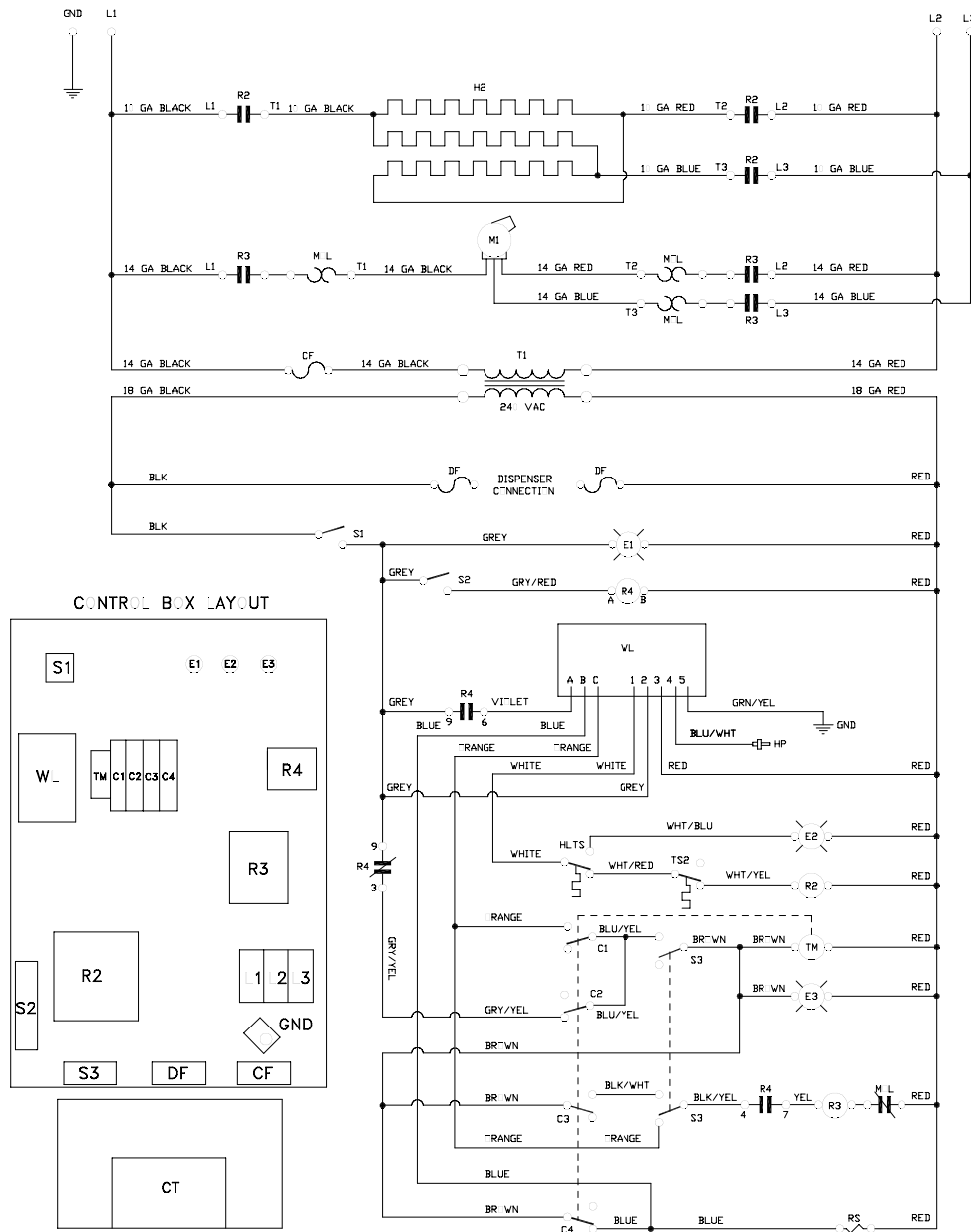

LEGEND

1 2 3	POWER DISTRIBUTION BLOCK	W	WATER LEVEL CONTROL
GND	GROUND	-P	-HIGH-LEVEL PROBE
-2	WAS-HEATER	TM	TIMER MOTOR
M1	WAS-MOTOR	C1	CYCLE SWITCH-
R2	WAS-HEATER CONTACTOR	C2	AUTO START RESET SWITCH-
R3	WAS-MOTOR CONTACTOR	C3	WAS-CYCLE SWITCH-
R4	CONTROL RELAY	C4	RINSE/FILL SOLENOID
S1	POWER SWITCH-	RS	RINSE/FILL SOLENOID
S2	DOOR SWITCH-	T1	CONTROL TRANSFORMER
S3	DETIME SWITCH-	M.L	MOTOR OVERLOAD
E1	POWER LIGHT	CF	CONTROL FUSE
E2	HEATER OVERLOAD LIGHT	DF	DISPENSER FUSE BLOCK
E3	CYCLE LIGHT		
TS2	WAS-HEATER T-TERM. STAT		
-TS	WAS- HIGH-LIMIT T-TERM. STAT		

9905-002-55-54d

SECTION 6: ELECTRICAL SCHEMATICS

TEMPSTAR S (TOP MOUNT MECHANICAL TIMER) 208-230 VOLT - 50/60 HERTZ - SINGLE & THREE PHASE

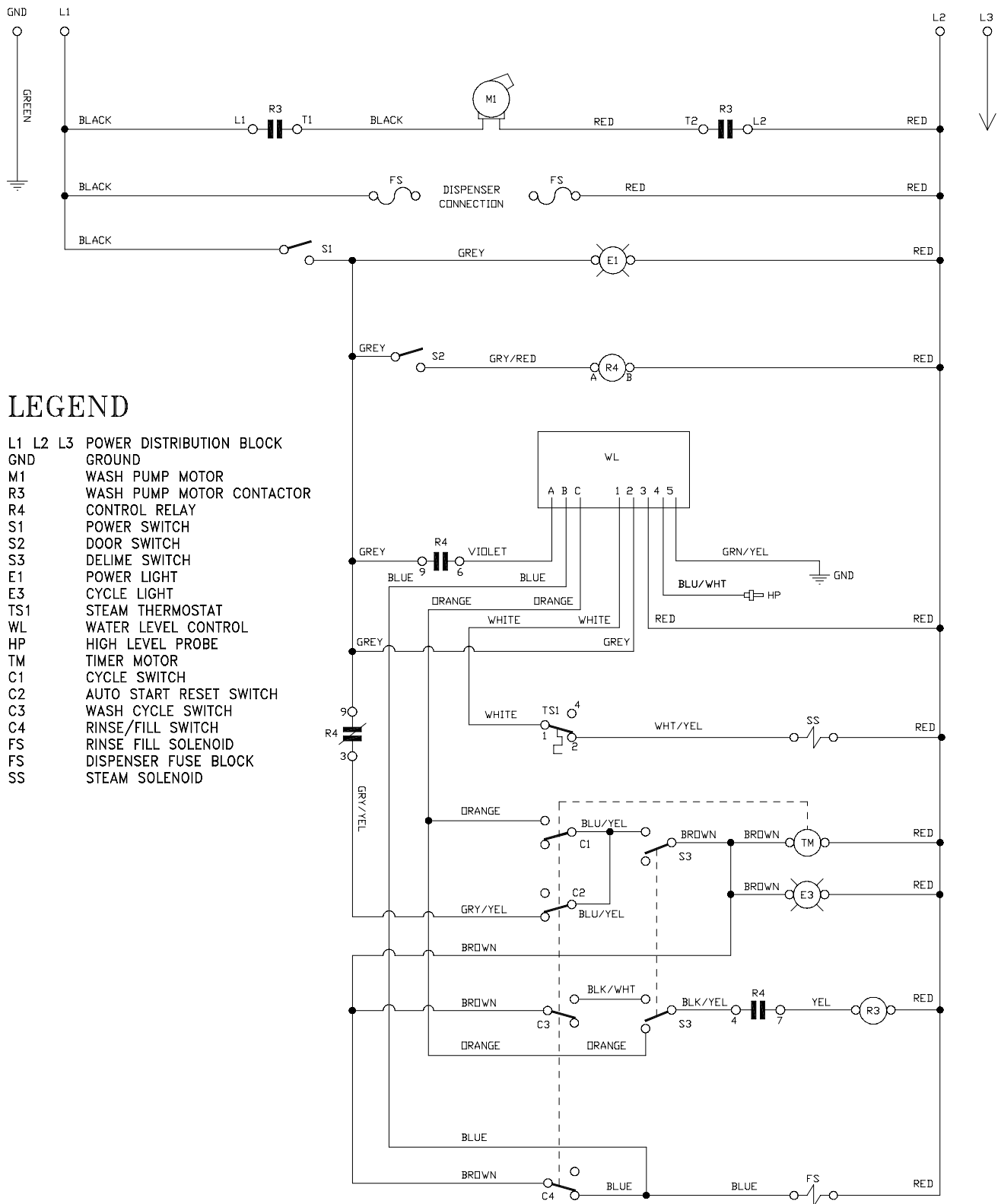

LEGEND

- L1 L2 L3 POWER DISTRIBUTION BLOCK
- GND GROUND
- M1 WASH PUMP MOTOR
- R3 WASH PUMP MOTOR CONTACTOR
- R4 CONTROL RELAY
- S1 POWER SWITCH
- S2 DOOR SWITCH
- S3 DELIME SWITCH
- E1 POWER LIGHT
- E3 CYCLE LIGHT
- TS1 STEAM THERMOSTAT
- WL WATER LEVEL CONTROL
- HP HIGH LEVEL PROBE
- TM TIMER MOTOR
- C1 CYCLE SWITCH
- C2 AUTO START RESET SWITCH
- C3 WASH CYCLE SWITCH
- C4 RINSE/FILL SWITCH
- FS RINSE FILL SOLENOID
- FS DISPENSER FUSE BLOCK
- SS STEAM SOLENOID

9905-002-15-84c

SECTION 6: ELECTRICAL SCHEMATICS

TEMPSTAR S (TOP MOUNT UNIVERSAL TIMER) 208-230 VOLT - 50/60 HERTZ - SINGLE & THREE PHASE

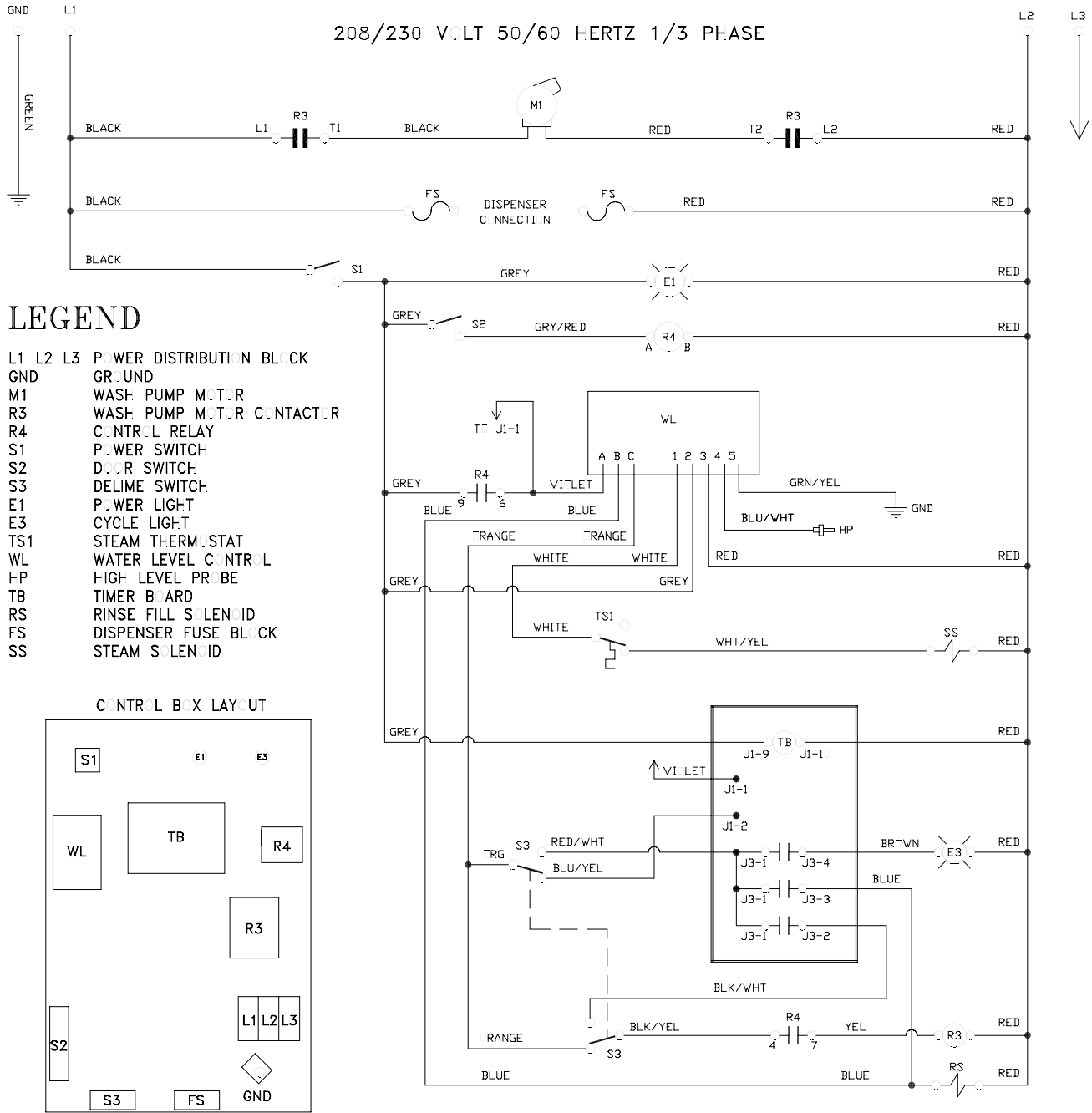

99'5-113-14-99

**SECTION 6B:
ELECTRICAL SCHEMATICS
FOR SIDE MOUNT UNITS**

SECTION 6: ELECTRICAL SCHEMATICS

TEMPSTAR (SIDE MOUNT) 208-230 VOLT - 50/60 HERTZ - SINGLE & THREE PHASE

LEGEND

- H1 RINSE HEATER
- H2 WASH HEATER
- M1 WASH MOTOR
- R1 RINSE HEATER CONTACTOR
- R2 WASH HEATER CONTACTOR
- R3 WASH MOTOR CONTACTOR
- R4 CONTROL RELAY
- S1 POWER SWITCH
- S2 DOOR SWITCH
- S3 DELIME SWITCH
- E1 POWER LIGHT
- E2 HEATER OVERLOAD LIGHT
- E3 CYCLE LIGHT
- TS1 RINSE HEATER THERMOSTAT
- TS2 WASH HEATER THERMOSTAT
- HLTS WASH HIGH LIMIT THERMOSTAT
- WL WATER LEVEL CONTROL
- HP HIGH LEVEL PROBE
- GND GROUND
- TM TIMER MOTOR
- C1 CYCLE SWITCH
- C2 AUTO START RESET SWITCH
- C3 WASH CYCLE SWITCH
- C4 RINSE/FILL SWITCH
- RS RINSE FILL SOLENOID
- CT COUNTER
- FS DISPENSER FUSE BLOCK

FRONT COVER LAYOUT

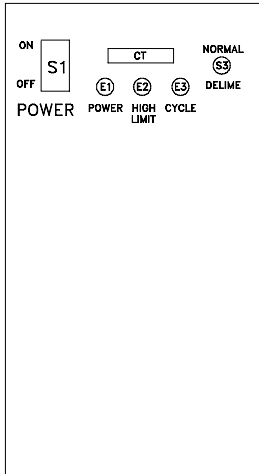

CONTROL BOX LAYOUT

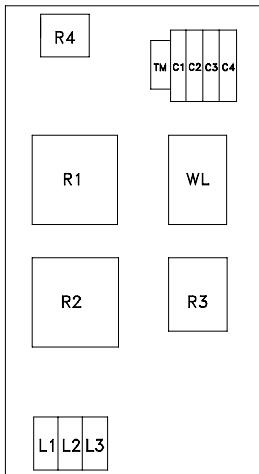

208/230 VOLT 50/60 HERTZ SINGLE PHASE

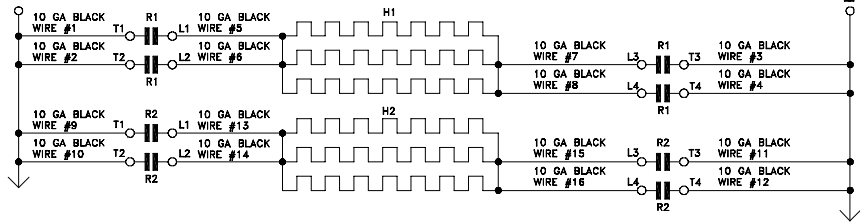

208/230 VOLT 50/60 HERTZ 3 PHASE

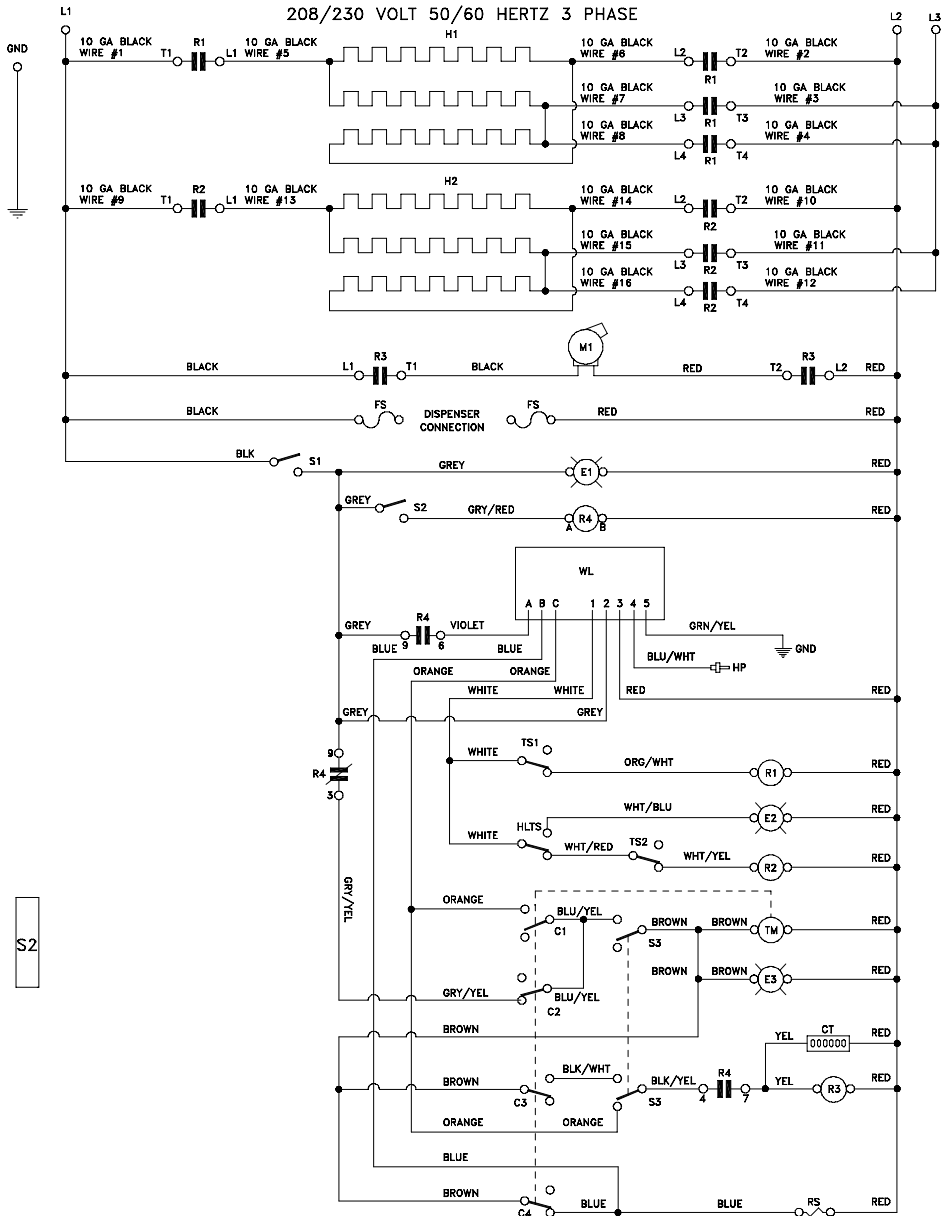

9905-031-64-37a

SECTION 6: ELECTRICAL SCHEMATICS

TEMPSTAR (SIDE MOUNT) 380 VOLT - 50 HERTZ - THREE PHASE

LEGEND

- H1 RINSE HEATER
- H2 WASH HEATER
- M1 WASH MOTOR
- R1 RINSE HEATER CONTACTOR
- R2 WASH HEATER CONTACTOR
- R3 WASH MOTOR CONTACTOR
- R4 CONTROL RELAY
- S1 POWER SWITCH
- S2 DOOR SWITCH
- S3 DELIME SWITCH
- E1 POWER LIGHT
- E2 HEATER OVERLOAD LIGHT
- E3 CYCLE LIGHT
- TS1 RINSE HEATER THERMOSTAT
- TS2 WASH HEATER THERMOSTAT
- HLTS WASH HIGH LIMIT THERMOSTAT
- WL WATER LEVEL CONTROL
- HP HIGH LEVEL PROBE
- GND GROUND
- TM TIMER MOTOR
- C1 CYCLE SWITCH
- C2 AUTO START RESET SWITCH
- C3 WASH CYCLE SWITCH
- C4 RINSE/FILL SWITCH
- FS RINSE FILL SOLENOID
- CT COUNTER
- MOL MOTOR OVERLOAD

FRONT COVER LAYOUT

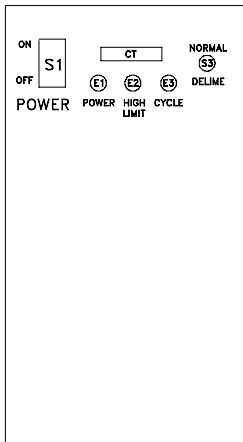

CONTROL BOX LAYOUT

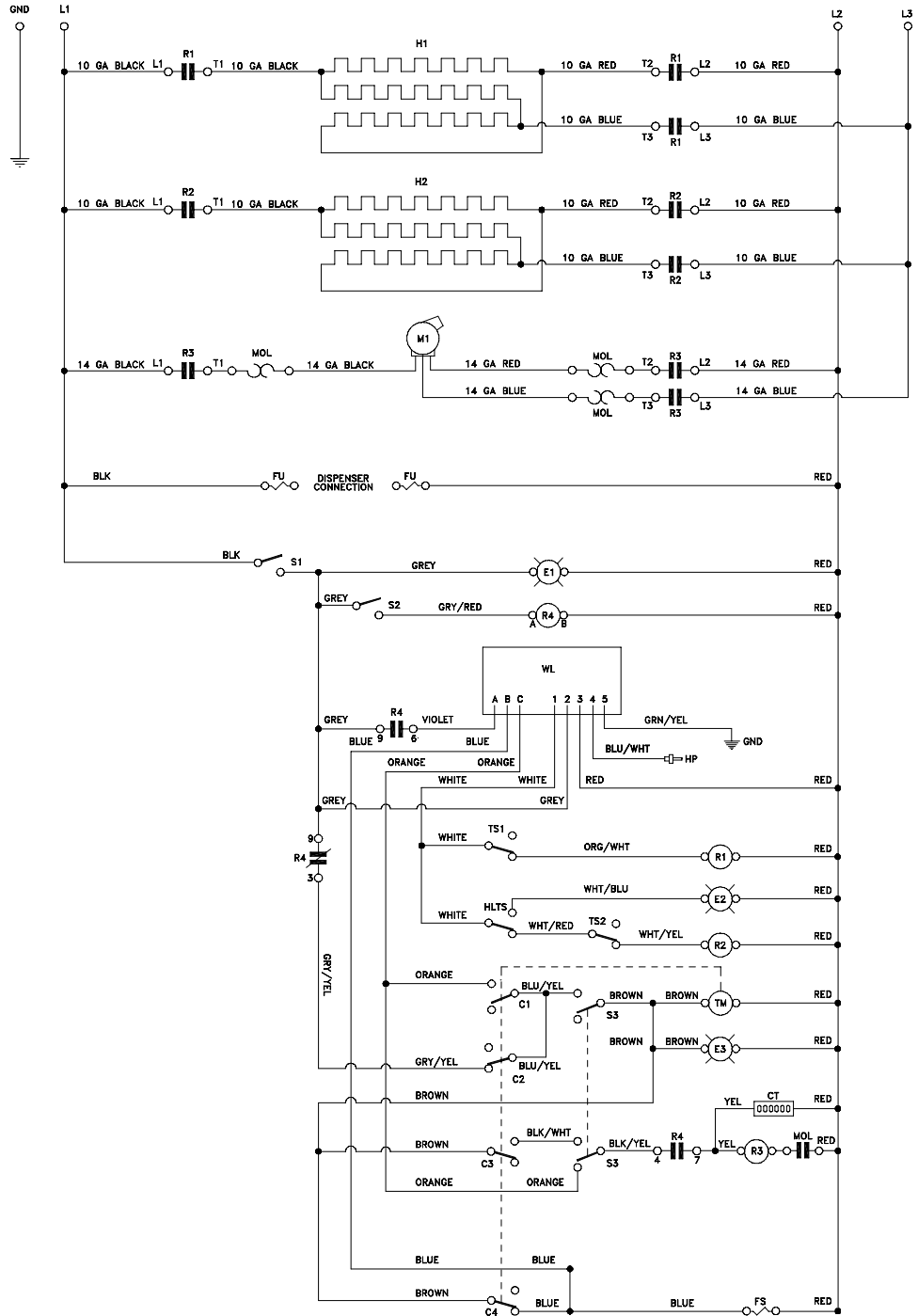
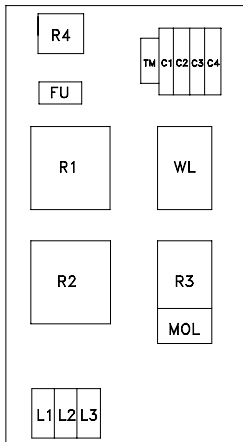

9905-031-90-10a

SECTION 6: ELECTRICAL SCHEMATICS

TEMPSTAR (SIDE MOUNT) 440-460 VOLT - 50/60 HERTZ - THREE PHASE

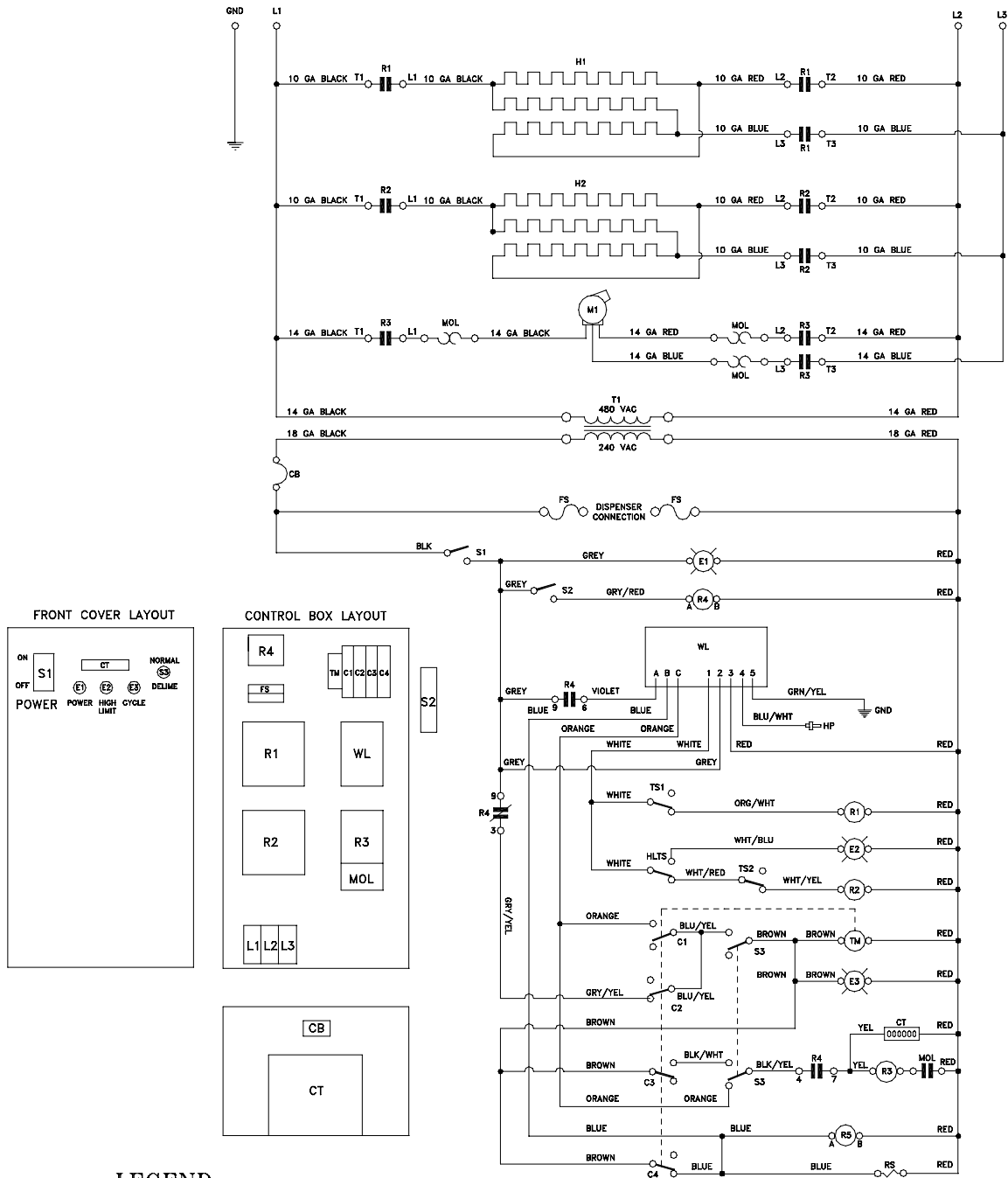

LEGEND

H1	RINSE HEATER	E1	POWER LIGHT	C1	CYCLE SWITCH
H2	WASH HEATER	E2	HEATER OVERLOAD LIGHT	C2	AUTO START RESET SWITCH
M1	WASH MOTOR	E3	CYCLE LIGHT	C3	WASH CYCLE SWITCH
R1	RINSE HEATER CONTACTOR	TS1	RINSE HEATER THERMOSTAT	C4	RINSE/FILL SWITCH
R2	WASH HEATER CONTACTOR	TS2	WASH HEATER THERMOSTAT	RS	RINSE FILL SOLENOID
R3	WASH MOTOR CONTACTOR	HLTS	WASH HIGH LIMIT THERMOSTAT	CT	COUNTER
R4	CONTROL RELAY	WL	WATER LEVEL CONTROL	RS	RINSE FILL SOLENOID (480V-240V)
S1	POWER SWITCH	HP	HIGH LEVEL PROBE	MOL	MOTOR OVERLOAD
S2	DOOR SWITCH	GND	GROUND	CB	CIRCUIT BREAKER
S3	DELIME SWITCH	TM	TIMER MOTOR	FS	DISPENSER FUSE BLOCK

09905-031-66-00

SECTION 6: ELECTRICAL SCHEMATICS

TEMPSTAR LT & TEMPSTAR NB (SIDE MOUNT) 208-230 VOLT - 50/60 HERTZ - SINGLE & THREE PHASE

LEGEND

- H2 WASH HEATER
- M1 WASH MOTOR
- R2 WASH HEATER CONTACTOR
- R3 WASH MOTOR CONTACTOR
- R4 CONTROL RELAY
- S1 POWER SWITCH
- S2 DOOR SWITCH
- S3 DELIME SWITCH
- E1 POWER LIGHT
- E2 HEATER OVERLOAD LIGHT
- E3 CYCLE LIGHT
- TS2 WASH HEATER THERMOSTAT
- HLTS WASH HIGH LIMIT THERMOSTAT
- WL WATER LEVEL CONTROL
- HP HIGH LEVEL PROBE
- GND GROUND
- TM TIMER MOTOR
- C1 CYCLE SWITCH
- C2 AUTO START RESET SWITCH
- C3 WASH CYCLE SWITCH
- C4 RINSE/FILL SWITCH
- RS RINSE FILL SOLENOID
- CT COUNTER
- FS DISPENSER FUSE BLOCK

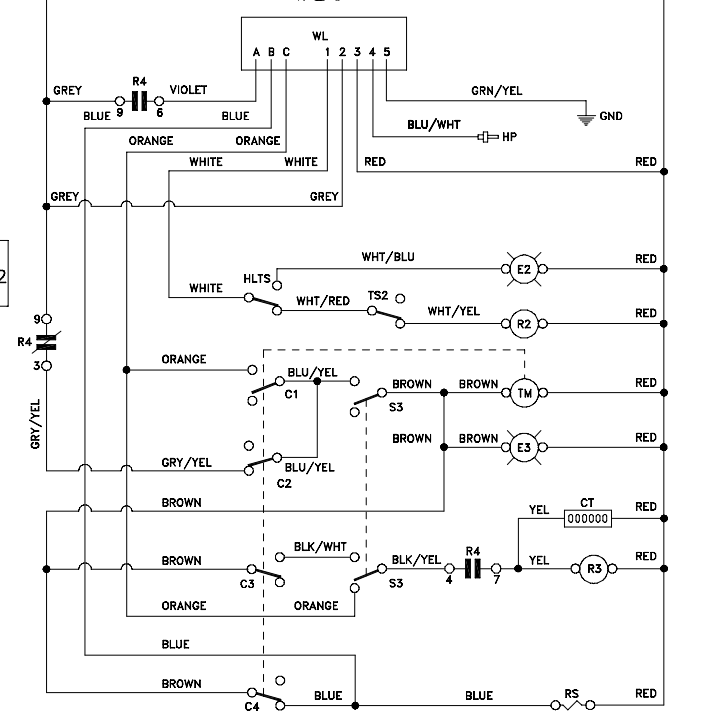
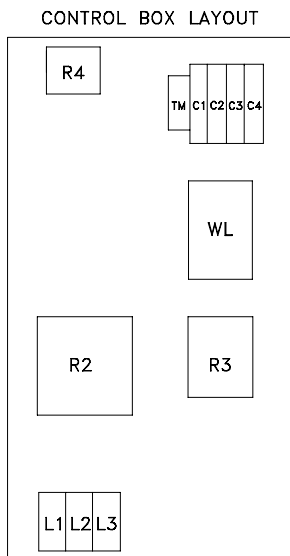
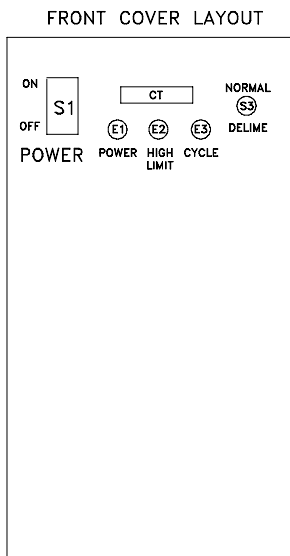
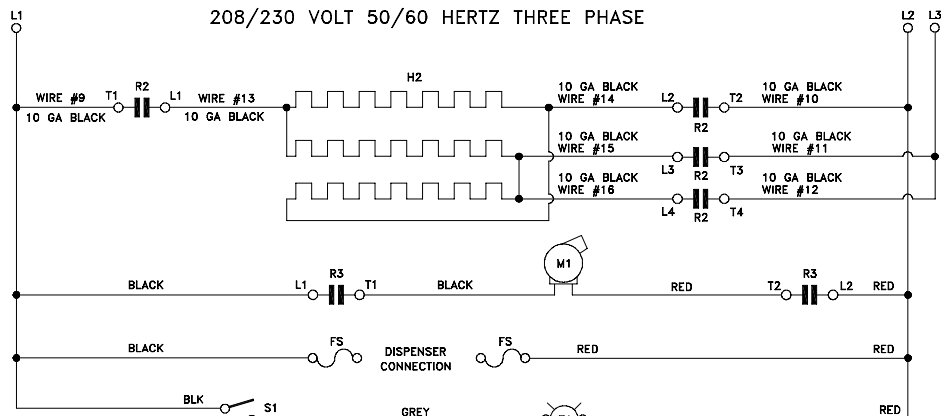
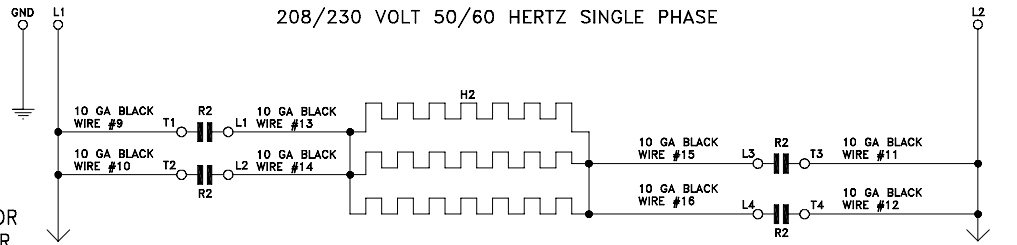

9905-002-24-02a

SECTION 6: ELECTRICAL SCHEMATICS

TEMPSTAR LT & TEMPSTAR NB (SIDE MOUNT) 380-440-460 VOLT - 50/60 HERTZ - THREE PHASE

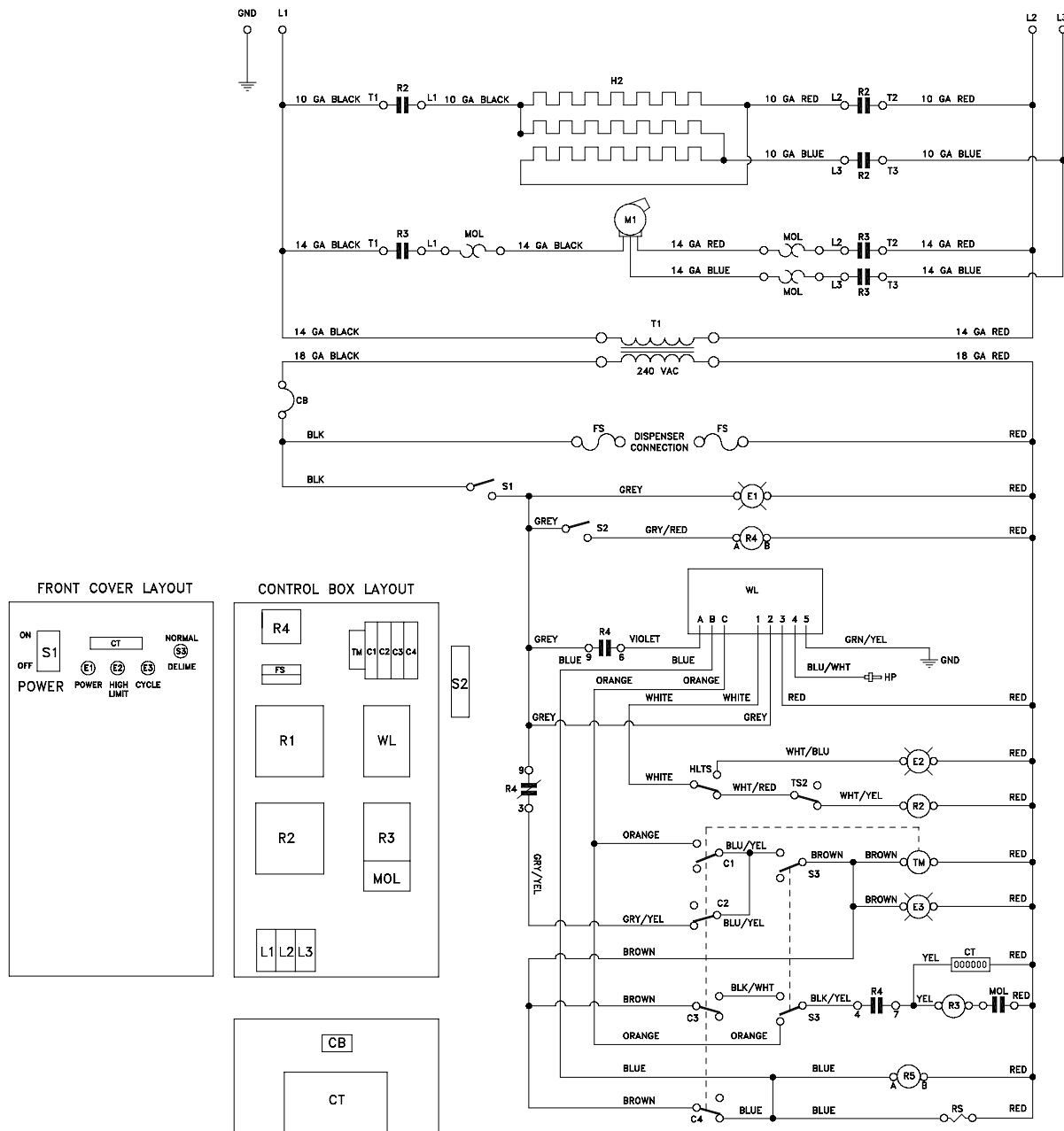

LEGEND

L1 L2 L3 POWER DISTRIBUTION BLOCK	E1 POWER LIGHT	C1 CYCLE SWITCH
GND GROUND	E2 HEATER OVERLOAD LIGHT	C2 AUTO START RESET SWITCH
H2 WASH HEATER	E3 CYCLE LIGHT	C3 WASH CYCLE SWITCH
M1 WASH MOTOR	TS2 WASH HEATER THERMOSTAT	C4 RINSE/FILL SWITCH
R2 WASH HEATER CONTACTOR	HLTS WASH HIGH LIMIT THERMOSTAT	RS RINSE FILL SOLENOID
R3 WASH MOTOR CONTACTOR	WL WATER LEVEL CONTROL	CT COUNTER
R4 CONTROL RELAY	HP HIGH LEVEL PROBE	T1 CONTROL TRANSFORMER
S1 POWER SWITCH	TM TIMER MOTOR	MOL MOTOR OVERLOAD
S2 DOOR SWITCH		CB CIRCUIT BREAKER
S3 DELIME SWITCH		FS DISPENSER FUSE BLOCK

SECTION 6: ELECTRICAL SCHEMATICS

TEMPSTAR SDS 208-230 VOLT - 60 HERTZ - SINGLE & THREE PHASE

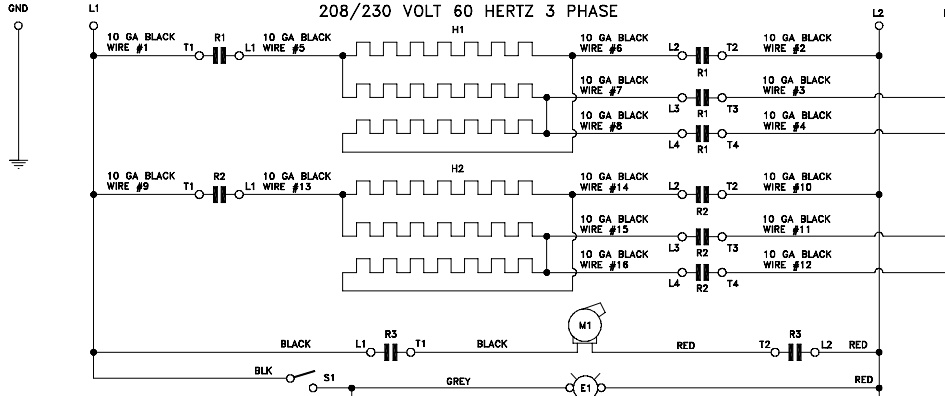
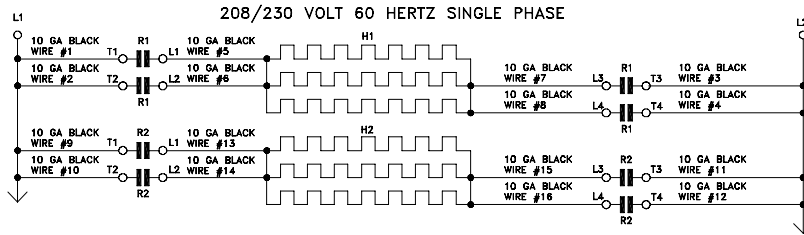

LEGEND

- H1 RINSE HEATER
- H2 WASH HEATER
- M1 WASH MOTOR
- R1 RINSE HEATER CONTACTOR
- R2 WASH HEATER CONTACTOR
- R3 WASH MOTOR CONTACTOR
- R4 CONTROL RELAY
- R5 RINSE AID RELAY
- S1 POWER SWITCH
- S2 DOOR SWITCH
- S3 DELIME SWITCH
- E1 POWER LIGHT
- E2 HEATER OVERLOAD LIGHT
- E3 CYCLE LIGHT
- TS1 RINSE HEATER THERMOSTAT
- TS2 WASH HEATER THERMOSTAT
- HLTS WASH HIGH LIMIT THERMOSTAT
- WL WATER LEVEL CONTROL
- HP HIGH LEVEL PROBE
- GND GROUND
- TM TIMER MOTOR
- C1 CYCLE SWITCH
- C2 AUTO START RESET SWITCH
- C3 WASH CYCLE SWITCH
- C4 RINSE/FILL SWITCH
- FS RINSE FILL SOLENOID
- CT COUNTER
- T1 60VA TRANSFORMER (208/230V-24V)

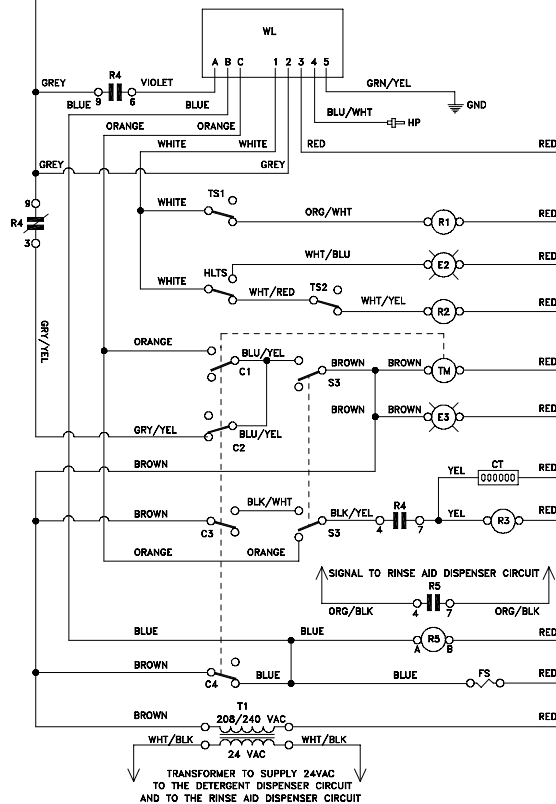

9905-031-46-66f

SECTION 6: ELECTRICAL SCHEMATICS

TEMPSTAR SDS 380-440-460 VOLT - 50/60 HERTZ - THREE PHASE

LEGEND

- L1 L2 L3 POWER DISTRIBUTION BLOCK
- GND GROUND
- H1 RINSE HEATER
- H2 WASH HEATER
- M1 WASH MOTOR
- R1 RINSE HEATER CONTACTOR
- R2 WASH HEATER CONTACTOR
- R3 WASH MOTOR CONTACTOR
- R4 CONTROL RELAY
- R5 RINSE AID RELAY
- S1 POWER SWITCH
- S2 DOOR SWITCH
- S3 DELIME SWITCH
- E1 POWER LIGHT
- E2 HEATER OVERLOAD LIGHT
- E3 CYCLE LIGHT
- TS1 RINSE HEATER THERMOSTAT
- TS2 WASH HEATER THERMOSTAT
- HLTS WASH HIGH LIMIT THERMOSTAT
- WL WATER LEVEL CONTROL
- HP HIGH LEVEL PROBE
- TM TIMER MOTOR
- C1 CYCLE SWITCH
- C2 AUTO START RESET SWITCH
- C3 WASH CYCLE SWITCH
- C4 RINSE/FILL SWITCH
- FS RINSE FILL SOLENOID
- CT COUNTER
- T1 DISPENSER TRANSFORMER
- T2 CONTROL TRANSFORMER
- MOL MOTOR OVERLOAD
- CB CIRCUIT BREAKER

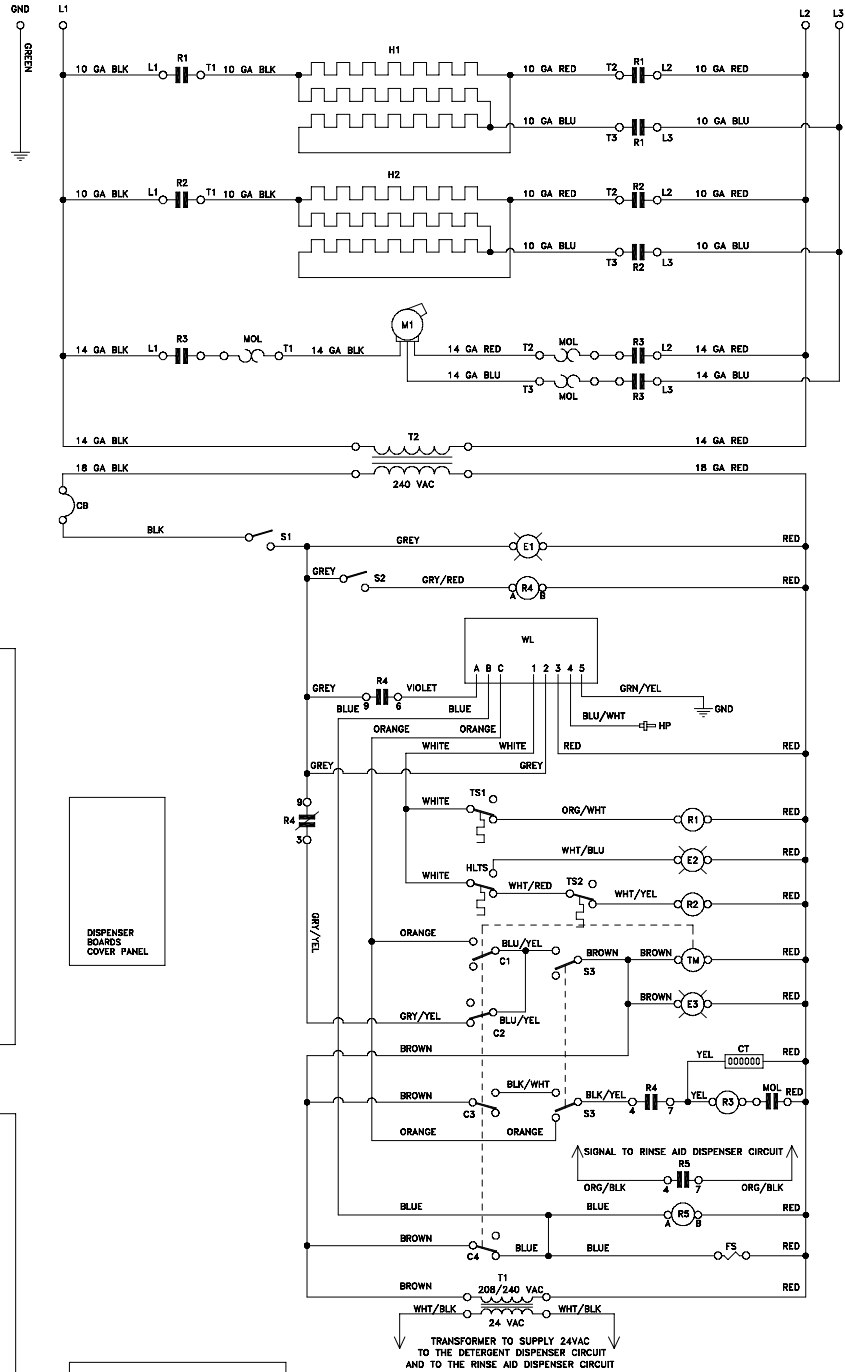

FRONT COVER LAYOUT

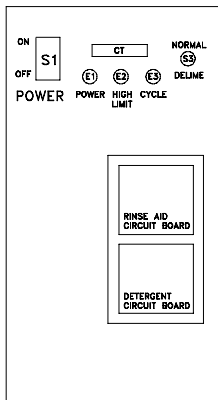

CONTROL BOX LAYOUT

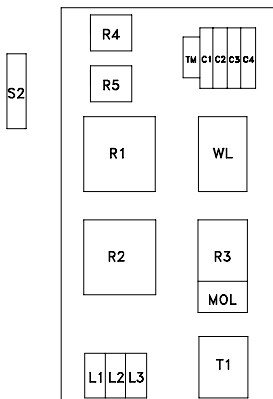

9905-002-64-62a

SECTION 6: ELECTRICAL SCHEMATICS

TEMPSTAR SDS 380-415 VOLT - 50 HERTZ - THREE PHASE - 5 WIRE

LEGEND

- H1 RINSE HEATER
- H2 WASH HEATER
- M1 WASH MOTOR
- R1 RINSE HEATER CONTACTOR
- R2 WASH HEATER CONTACTOR
- R3 WASH MOTOR CONTACTOR
- R4 CONTROL RELAY
- R5 RINSE AID RELAY
- S1 POWER SWITCH
- S2 DOOR SWITCH
- S3 DELIME SWITCH
- E1 POWER LIGHT
- E2 HEATER OVERLOAD LIGHT
- E3 CYCLE LIGHT
- TS1 RINSE HEATER THERMOSTAT
- TS2 WASH HEATER THERMOSTAT
- HLTS WASH HIGH LIMIT THERMOSTAT
- WL WATER LEVEL CONTROL
- HP HIGH LEVEL PROBE
- GND GROUND
- TM TIMER MOTOR
- C1 CYCLE SWITCH
- C2 AUTO START RESET SWITCH
- C3 WASH CYCLE SWITCH
- C4 RINSE/FILL SWITCH
- FS RINSE FILL SOLENOID
- CT COUNTER
- T1 60VA TRANSFORMER (208/230V-24V)
- MOL MOTOR OVERLOAD
- CB CIRCUIT BREAKER

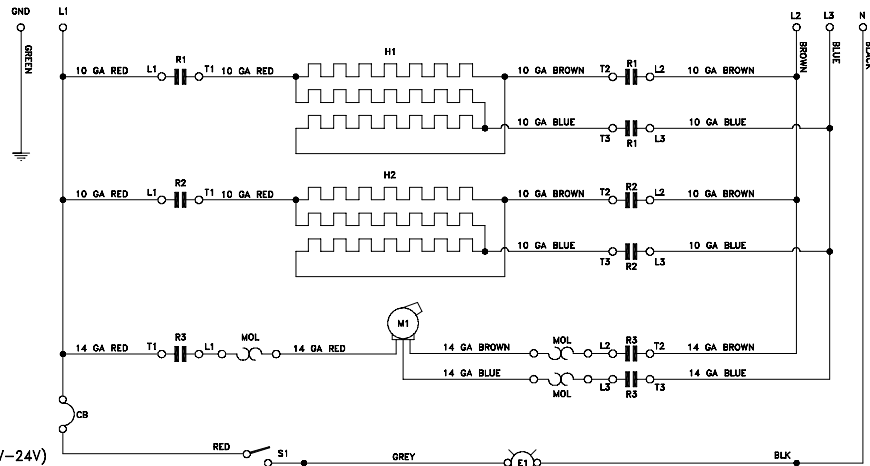

FRONT COVER LAYOUT

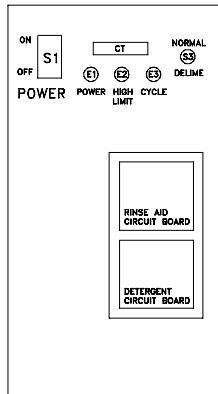

CONTROL BOX LAYOUT

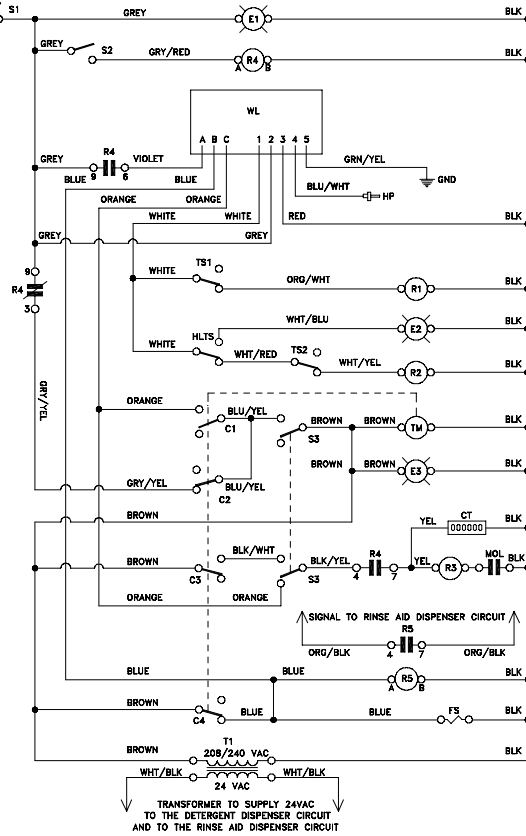
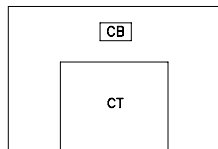
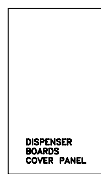
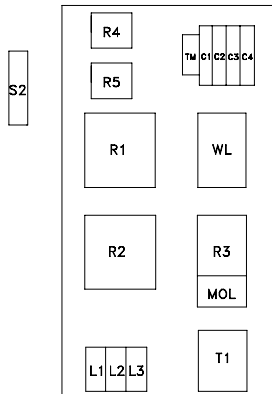

9905-031-64-16b

SECTION 6: ELECTRICAL SCHEMATICS

TEMPSTAR SDS DISPENSER SCHEMATIC

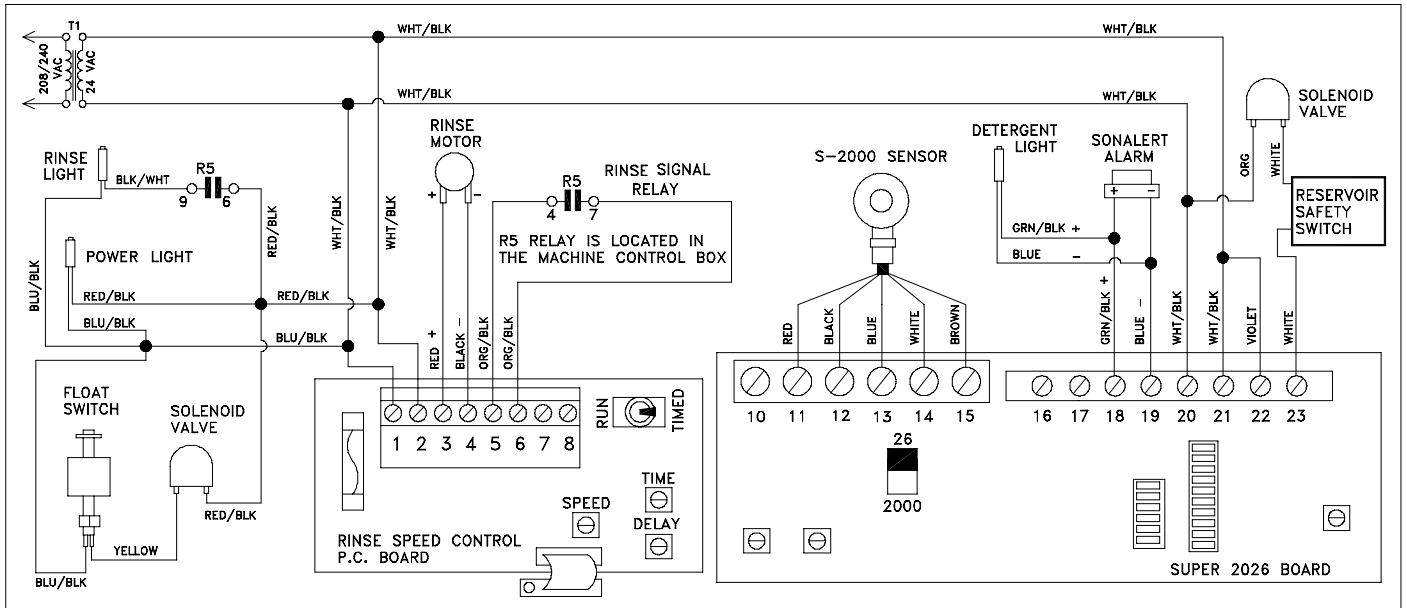

09905-011-48-52

**SECTION 6C:
ELECTRICAL SCHEMATICS
FOR OPTIONS**

SECTION 6: ELECTRICAL SCHEMATICS

SDI OPTION

TEMPSTAR SDI OPTION

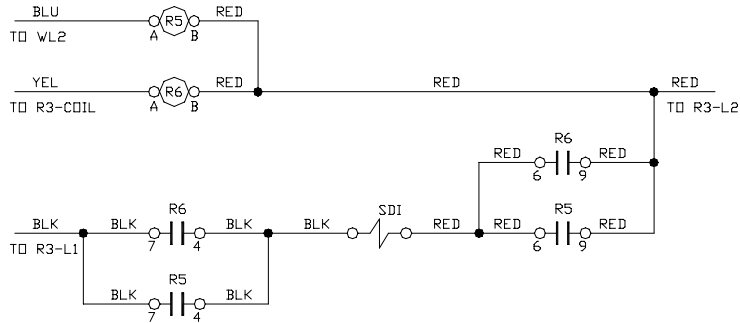

LEGEND

- R5 RINSE RELAY
- R6 WASH RELAY
- SDI SAFETY DOOR INTERLOCK SOLENOID

09905-002-35-85a

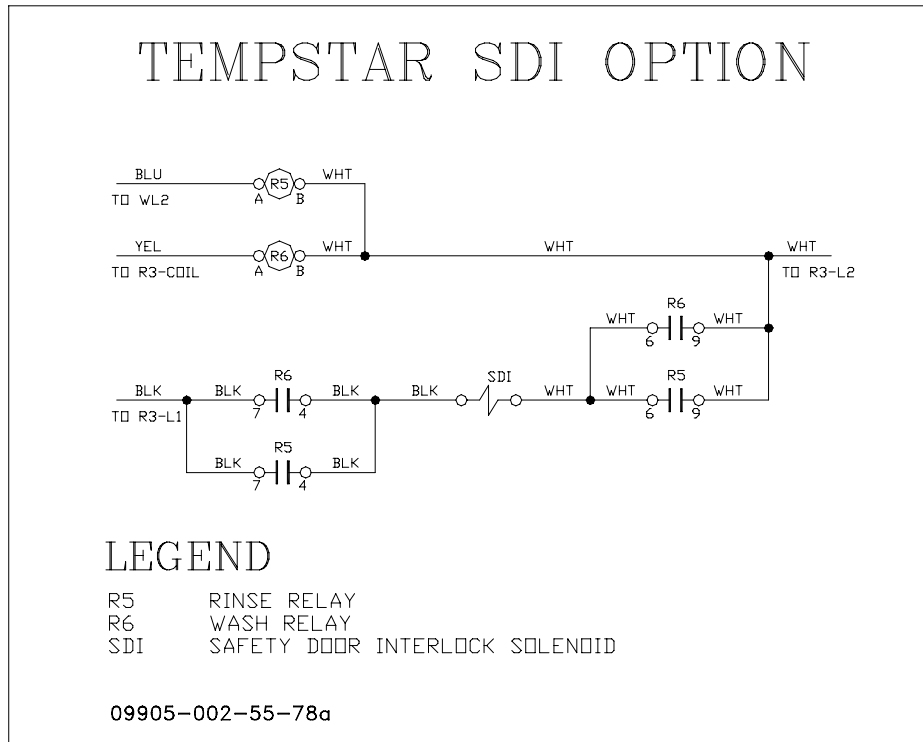

SECTION 6: ELECTRICAL SCHEMATICS
EXHAUST FAN HOOKUP/DRAIN QUENCH OPTIONS

DRAIN QUENCH SYSTEM

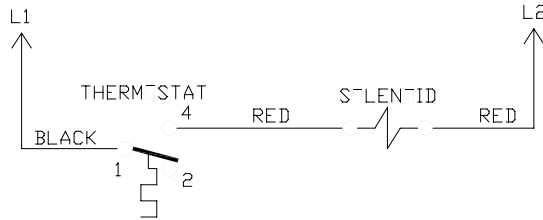

CONNECT BLACK WIRE TO MOTOR CONTACTOR - L1 WITH PIGGYBACK TERMINAL PROVIDED
 CONNECT WHITE WIRE TO MOTOR CONTACTOR - L2 WITH PIGGYBACK TERMINAL PROVIDED

TEMPSTAR EXHAUST FAN HOOKUP

LEGEND

T TIMER
 TB TERMINAL BOARD

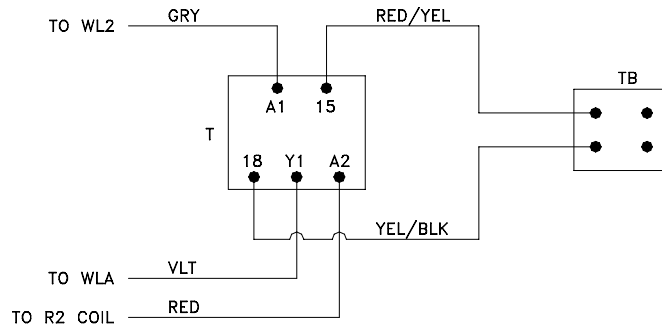

9905-002-54-41

**SECTION 7:
JACKSON MAINTENANCE &
REPAIR CENTERS**

SECTION 7: JACKSON MAINTENANCE & REPAIR CENTERS

ALABAMA TO FLORIDA

ALABAMA

JONES-McLEOD APPLIANCE SVC

1616 7TH AVE. NORTH
BIRMINGHAM, AL 35203
(205) 251-0159
800-821-1150
FAX: (205) 322-1440
service@jones-mcleod.com

JONES-McLEOD APPLIANCE SVC

854 LAKESIDE DRIVE
MOBILE, AL 36693
(251) 666-7278
800-237-9859
FAX: (251) 661-0223

ALASKA

RESTAURANT APPLIANCE SERVICE

7219 ROOSEVELT WAY NE
SEATTLE, WA 98115
(206) 524-8200
800-433-9390
FAX: (206) 525-2890
info@restappl.com

ARIZONA

AUTHORIZED COMMERCIAL FOOD EQMT. SVC

4832 SOUTH 35TH STREET
PHOENIX, AZ 85040
(602) 234-2443
800-824-8875
FAX: (602) 232-5862
acsboss@aol.com

GCS SERVICE INC.

PHOENIX, AZ
(602) 474-4510
800-510-3497
FAX: (602) 470-4511

ARKANSAS

BROMLEY PARTS & SVC

10TH AND RINGO
P.O. BOX 1688
LITTLE ROCK, AR 72202
(501) 374-0281
800-482-9269
FAX: (501) 374-8352
service@bromleyparts.com
parts@bromleyparts.com

GCS SERVICE, INC.

3717 CHERRY ROAD
MEMPHIS, TN 38118
(901) 366-4587
800-262-9155
FAX: (901) 366-4588

CALIFORNIA

BARKERS FOOD MACHINERY SERVICES

5367 SECOND STREET
IRWINDALE, CA 91706
(626) 960-9390
800-258-6999
FAX: (626) 337-4541
service@barkers.com

GCS SERVICE INC.

LOS ANGELES, CA
(213) 683-2090
800-327-1433
FAX: (213) 683-2099

GCS SERVICE INC.

SANTA ANA, CA
(714) 542-1798
800-540-0719
FAX: (714) 542-4787

GCS SERVICE INC.

S. SAN FRANCISCO, CA
(650) 635-0720
800-969-4427
FAX: (650) 871-4019

COMMERCIAL APPLIANCE SERVICE, INC.

6507 PACIFIC AVENUE, SUITE 102
STOCKTON, CA 95207
(916) 567-0203
(800) 464-2222
(916) 567-0266 FAX

GCS SERVICE INC.

SAN DIEGO, CA
(858) 549-8411
800-422-7278
FAX: (858) 549-2323

INDUSTRIAL ELECTRIC SVC.

5662 ENGINEER DRIVE
HUNTINGTON BEACH, CA 92649
(714) 379-7100
(800-457-3783
FAX: (714) 379-7109

P & D APPLIANCE SVC

100 SOUTH LINDEN AVE.
S. SAN FRANCISCO, CA 94080
(650) 635-1900
800-424-1414
FAX: (650) 635-1919
pndappl@aol.com

P & D APPLIANCE

4220-C ROSEVILLE ROAD
NORTH HIGHLANDS, CA 95660
(916) 974-2772
800-824-7219
FAX: (916) 974-2774

COMMERCIAL APPLIANCE SERVICE, INC.

281 LATHROP WAY, #100
SACRAMENTO, CA 95815
(916) 567-0203
(800) 464-2222
(916) 567-0324 FAX

COLORADO

GCS SERVICE INC.

SHERIDAN, CO
(303) 371-9054
800-972-5314
FAX: (303) 371-4754

HAWKINS COMMERCIAL APPLIANCE SERVICE

3000 S. WYANDOT ST.
ENGLEWOOD, CO 80110
(303) 781-5548
(800) 624-2117
FAX: (303) 761-5561
johns@hawkinscommercial.com

METRO APPLIANCE SERVICE

1640 S BROADWAY
DENVER, CO 80210
(303) 778-1126
800-525-3532
FAX: (303) 778-0268
metroappls@aol.com

CONNECTICUT

GCS SERVICE INC.

HARTFORD, CT
(860) 549-5575
800-423-1562
FAX: (860) 527-6355

SUPERIOR KITCHEN SERVICE INC.

22 THOMPSON ROAD
WINDSOR, CT 06088
(888) 590-1899
(888) 590-1996 FAX

DELAWARE

FOOD SERVICE EQMT.

2101 PARKWAY SOUTH
BROOMALL, PA 19008
(610) 356-6900
FAX: (610) 356-2038
dancerule@aol.com

GCS SERVICE INC.

PHILADELPHIA, PA
(215)925-6217
800-441-9115
FAX: (215) 925-6208

ELMER SCHULTZ SERVICE

36 BELMONT AVE.
WILLMINGTON, DE 19804
(302) 655-8900
800-225-0599
FAX: (302) 656-3673
elmer2@erols.com

EMR SERVICE DIVISION

106 WILLIAMSPORT CIRCLE
SALISBURY, MD 21804
(410) 543-8197
FAX: (410) 548-4038

FLORIDA

COMMERCIAL APPLIANCE SERVICE

8416 LAUREL FAIR CIRCLE
BLDG 6, SUITE 114
TAMPA, FL 33610
(813) 663-0313
800-282-4718
FAX: (813) 663-0212
commercialappliance@world-net.att.net

GCS SERVICE INC

MIAMI, FL
(305) 621-6666
800-766-8966
FAX: (305) 621-6656

GCS SERVICE INC

ORLANDO, FL
(407) 841-2551
800-338-7322
FAX: (407) 423-8425

NASS PARTS AND SERVICE, INC.

1144 BELVILLE ROAD, UNIT 359
DAYTONA BEACH, FL 32114
(386) 226-2642
(800) 432-2795
(386) 736-7695 FAX

GCS SERVICE INC

TAMPA, FL
(813) 626-6044
800-282-3008
FAX: (813) 621-1174

SECTION 7: JACKSON MAINTENANCE & REPAIR CENTERS

FLORIDA TO MARYLAND

JONES-McLEOD APPLIANCE SVC

854 LAKESIDE DRIVE
MOBILE, AL 36693
(251) 666-7278
800-237-9859
FAX: (251) 661-0223
service@jones-mcleod.com

NASS PARTS AND SERVICE, INC.

1108 SOUTH WOODS AVENUE
ORLANDO, FL 32805
(407) 425-2681
(800) 432-2795
(407) 425-3463 FAX

NASS PARTS AND SERVICE, INC.

1376 HEIDE AVENUE
PALM BAY, FL 32907
(321) 952-2012
(800) 432-2795
(321) 953-0266 FAX

GEORGIA

GCS SERVICE INC

ATLANTA, GA
(770) 452-7322
800-334-3599
FAX: (770) 452-7473

HERITAGE FOODSERVICE

GROUP OF ATLANTA
2100 NORCROSS PKWY.
SUITE 130
NORCROSS, GA 30071
(770) 368-1465
866-388-9837
FAX: (866) 388-9838

WHALEY FOODSERVICE REPAIRS

109-A OWENS INDUSTRIAL DRIVE
SAVANNAH, GA 31405
(912) 447-0827
888-765-0036
FAX: (912) 447-0826

PIERCE PARTS & SERVICE

2422 ALLEN ROAD
MACON, GA 31216
(478) 781-6003
800-368-2512
FAX: (478) 781-7186

HAWAII

FOOD EQMT. PARTS & SERVICE CO.

300 PUUHALE RD.
HONOLULU, HI 96819
(808) 847-4871
FAX: (808) 842-1560
fepsco@hula.net

IDAHO

RESTAURANT APPLIANCE SVC.

7219 ROOSEVELT WAY NE
SEATTLE, WA 98115
(206) 524-8200
800-433-9390
FAX: (206) 525-2890
info@restappl.com

RON'S SERVICE

703 E 44TH STREET STE 10
GARDEN CITY, ID 83714
(208) 375-4073
FAX: (208) 375-4402

ILLINOIS

CONES REPAIR SVC.

2408 40TH AVE.
MOLINE, IL 61265
(309) 797-5323
800-716-7070
FAX: (309) 797-3631
jackb@cones.com

EICHENAUER SERVICES INC.

130 S OAKLAND ST.
DECATUR, IL 62522
(217) 429-4229
800-252-5892
FAX: (217) 429-0226
esi@esiquality.com

GCS SERVICE INC.

ELMHURST, IL
(630) 941-7800
800-942-9689
FAX: (630) 941-6048

GCS SERVICE INC.

ST. LOUIS, MO
(314) 683-7444
800-284-4427
FAX: (314) 638-0135

GENERAL PARTS, INC.

248 JAMES STREET
BENSONVILLE, IL 60106
(630) 595-3300
(800) 880-3604
FAX: (630) 595-0006

INDIANA

GCS SERVICE INC.

INDIANAPOLIS, IN
(317) 545-9655
800-727-8710
FAX: (317) 549-6286

B622 LA PAS TRAIL

INDIANAPOLIS, IN 46268
(317) 290-8060
(800) 410-9794
(317) 290-8085 FAX

IOWA

GOODWIN TUCKER GROUP

2900 DELAWARE AVENUE

DES MOINES, IA 50317
(515) 262-9308
800-372-6066
FAX: (515) 262-2936
parts@goodwintucker.com

CONES REPAIR SVC.

1056 27TH AVENUE SW
CEDAR RAPIDS, IA 52404
(319) 365-3325
800-747-3326
FAX: (319) 365-0885

KANSAS

GCS SERVICE INC.

KANSAS CITY, MO
(816) 920-5999
800-229-6477
FAX: (816) 920-7387

GENERAL PARTS, INC.

1101 E. 13TH STREET
KANSAS CITY, MO 64106
(816) 421-5400
(800) 279-9967
(816) 421-1270 FAX

KENTUCKY

CERTIFIED SERVICE CENTER

127 DISHMAN LANE
BOWLING GREEN, KY 42101
(270) 783-0012
(877) 907-0012
FAX: (270) 783-0058

CERTIFIED SERVICE CENTER

RAMCO BUSINESS PARK

4283 PRODUCE ROAD
LOUISVILLE, KY 40218
(502) 964-7007
800-637-6350
FAX: (502) 964-7202
cwalker@certifiedsc.com
droenigk@certifiedsc.com

CERTIFIED SERVICE CENTER

1051 GOODWIN DRIVE
LEXINGTON, KY 40505
(606) 254-8854
800-432-9269
FAX: (606) 231-7781
jatkings@certifiedsc.com

GCS SERVICE INC.

LOUISVILLE, KY
(502) 367-1788
800-752-6160
FAX: (502) 367-0400

GCS SERVICE INC.

LEXINGTON, KY
(606) 255-0746
800-432-9260
FAX: (606) 255-0748

LOUISIANA

HERITAGE SERVICE GROUP

1532 RIVER OAKS WEST
NEW ORLEANS, LA 70123
(504) 734-8864
(800) 499-2351
(504) 733-2559 FAX

MAINE

GCS SERVICE INC.

CHELSEA, MA
(617) 889-9393
800-225-1155
FAX: (617) 889-1222

MASSACHUSETTS RESTAURANT SUPPLY

34 SOUTH STREET
SOMERVILLE, MA 02143
(617) 868-1930
800-338-6737
FAX: (617) 686-5331

PINE TREE FOOD EQUIPMENT

175 LEWISTON ROAD
GRAY, ME 04039
(207) 657-6400
(800) 540-5427
(207) 657-5464 FAX

MARYLAND

EMR SERVICE DIVISION

700 EAST 25TH STREET
BALTIMORE, MD 21218
(410) 467-8080
800-879-4994
FAX: (410) 467-4191
baltparts@emrco.com

SECTION 7: JACKSON MAINTENANCE & REPAIR CENTERS

MARYLAND TO NEW YORK

EMR SERVICE DIVISION
106 WILLIAMSPORT CIRCLE
SALISBURY, MD 21804
(410) 543-8197
888-687-8080
FAX: (410) 548-4038
baltparts@emrco.com

EMR SERVICE DIVISION

5316 Sunnyside Ave.
Beltsville, MD 20715
(301) 931-7000
800-348-2365
FAX: (301) 931-3060
baltparts@emrco.com

GCS SERVICE INC.

SILVER SPRING, MD
(301) 585-7550 (DC)
(410) 792-0338 (BALT)
(800) 638-7278
FAX: (301) 495-4410

MASSACHUSETTS

ACE SERVICE CO.

95 HAMPTON AVE.
NEEDHAM, MA 02494
(781) 449-4220
800-225-4510 MA & NH
FAX: (781) 444-4789
taceservice@aol.com

**MASSACHUSETTS RESTAU-
RANT SUPPLY**

34 SOUTH STREET
SOMERVILLE, MA 02143
(617) 868-1930
800-338-6737
FAX: (617) 868-5331

GCS SERVICE INC.

CHELSEA, MA
(617) 889-9393
800-225-1155
FAX: (617) 889-1222

GCS SERVICE INC.

HARTFORD, CT
(860) 549-5575
800-723-1562
FAX: (860) 527-6355

**SUPERIOR KITCHEN SER-
VICE INC.**

399 FERRY STREET
EVERETT, MA 02149
(617) 389-1899
(888) 590-1899
(617) 389-1996 FAX

MICHIGAN

GCS SERVICE INC.

LIVONIA, MI
(248) 426-9500
800-772-2936
FAX: (248) 426-7555

**JACKSON SERVICE COMPA-
NY**

3980 BENSTEIN RD.
COMMERCE TWSHP, MI 48382
(248) 363-4159
800-332-4053
FAX: (248) 363-5448

GCS SERVICE INC.

GRAND RAPIDS, MI
(616) 241-0200
800-823-4866
FAX: (616) 241-0541

MINNESOTA

GCS SERVICE INC.

MINNEAPOLIS, MN
(612) 546-4221
800-345-4221
FAX: (612) 546-4286

GENERAL PARTS, INC.

11311 HAMPSHIRE AVENUE
SOUTH
BLOOMINGTON, MN 55438-
2456
(952) 944-5800
(800) 279-9980
(800) 279-9980 FAX

MISSISSIPPI

GCS SERVICE INC.

JACKSON, MS
(601) 956-7800
800-274-5954
FAX: (601) 956-1200

GCS SERVICE INC.

MEMPHIS, TN
(901) 366-4587
800-262-9155
FAX: (901) 366-4588

MISSOURI

GCS SERVICE INC.

KANSAS CITY, MO
(816) 920-5999
800-229-6477
FAX: (816) 920-7387

GCS SERVICE INC.

ST. LOUIS, MO
(314) 638-7444
800-284-4427
FAX: (314) 638-0135

KAEMMERLIN PARTS & SVC.

2728 LOCUST STREET
ST. LOUIS, MO 63103
(314) 535-2222
FAX: (314) 535-6205
petek@kps.stl.com

GENERAL PARTS, INC.

1101 EAST 13TH STREET
KANSAS CITY, MO 64106
(816) 421-5400
(800) 279-9967
(816) 421-1270 FAX

MONTANA

**RESTAURANT APPLIANCE
SVC.**

7219 ROOSEVELT WAY NE
SEATTLE, WA 98115
(206) 524-8200
800-433-9390
FAX: (206) 525-2890
info@restappl.com

NEBRASKA

GOODWIN - TUCKER GROUP

7535 D STREET
OMAHA, NE 68124
(402) 397-2880
800-228-0342
FAX: (402) 397-2881
askme@goodwintucker.com

NEVADA

**HI TECH COMMERCIAL SER-
VICE**

1840 STELLA LAKE STREET
NORTH LAS VEGAS, NV 89106
(702) 649-4616
(877) 924-4832
FAX: (702) 649-4607
larry@hitechnv.com

5454 LOUIE LANE
RENO, NV 89511
(775) 852-9696
FAX: (775) 852-5104

GCS SERVICE INC.

LAS VEGAS, NV
(702) 450-3495
800-500-9060
FAX: (702) 450-3491

NEW HAMPSHIRE

GCS SERVICE INC.

CHELSEA, MA
(617)889-9393
800-225-1155
FAX: (617) 889-1222

ACE SERVICE CO.

95 HAMPTON AVE.
NEEDHAM, MA 02494
(781) 449-4220
800-225-4510 MA & NH
FAX: (781) 444-4789
taceservice@aol.com

**MASSACHUSETTS RESTAU-
RANT SUPPLY**

34 SOUTH STREET
SOMERVILLE, MA 02143
(617) 868-1930
800-338-6737
FAX: (617) 868-5331

NEW JERSEY

JAY HILL REPAIRS

90 CLINTON RD.
FAIRFIELD, NJ 07004
(973) 575-9145
800-836-0643
FAX: (973) 575-5890
jhrepair@aol.com

GCS SERVICE INC.

EAST RUTHERFORD, NJ
(973) 614-0003
800-399-8294
FAX: (973) 614-0230

GCS SERVICE INC.

PHILADELPHIA, PA
(215) 925-6217
800-441-9115
FAX: (215) 925-6208

ELMER SCHULTZ SERVICES

201 W. WASHINGTON AVE.
PLEASANTVILLE, NJ 08232
(609) 641-0317
800-378-1641
FAX:(609) 641-8703
elmer2@erols.com

NEW YORK

**APPLIANCE INSTALLATION
AND SERVICE CORP.**

1336 MAIN STREET
BUFFALO, NY 14209
(716) 884-7425
800-722-1252
FAX: (716) 884-0410
ais@worldnet.att.net

SECTION 7: JACKSON MAINTENANCE & REPAIR CENTERS

NEW YORK TO PENNSYLVANIA

B.E.S.T. INC.

3003 GENESEE STREET
BUFFALO, NY 14225
(716) 893-6464
800-338-5011
FAX: (716) 893-6466
bestserv@aol.com

DUFFY'S EQUIPMENT SVC.

3138 ONEIDA STREET
SAUQUOIT, NY 13456
(315) 737-9401
800-443-8339
FAX: (315) 737-7132
duffyequip@aol.com

NORTHERN PARTS & SVC.

21 NORTHERN AVENUE
PLATTSBURGH, NY 12903
(518) 563-3200
800-634-5005
FAX: (800) 782-5424
info@northernparts.com

GCS SERVICE INC.

BROOKLYN, NY
(718) 486-5220
800-969-4271
FAX: (718) 486-6772

ALL SERVICE KITCHEN

EQUIPMENT REPAIR
10 CHARLES ST.
NEW HYDE PARK, NY 11040
(516) 378-1176
FAX: (516) 378-1735

ALL ISLAND REPAIRS

40-9 BURT DRIVE
DEER PARK, NY 11729
(631) 242-5588
FAX: (631) 242-6102

NORTH CAROLINA

AUTHORIZED APPLIANCE

SERVICECENTER
1020 TUCKASEEGEE RD.
CHARLOTTE, NC 28208
(704) 377-4501
(800) 532-6127
FAX:(704) 377-4504

AUTHORIZED APPLIANCE

SERVICECENTER
800 N. PERSON ST.
RALEIGH, NC 27604
(919) 834-3476
FAX:(919) 834-3477

AUTHORIZED APPLIANCE

SERVICECENTER
904 S. MARSHALL ST.
WINSTON-SALEM, NC 27403
(336) 725-5396
FAX:(336) 721-1289

AUTHORIZED APPLIANCE

SERVICECENTER
104 HINTON AVE.
WILMINGTON, NC 28403
(910) 313-1250
FAX:(910) 313-6130

WHALEY FOODSERVICE

8334-K ARROWRIDGE BLVD
CHARLOTTE, NC 28273
(704) 529-6242
FAX: (704) 529-1558
info@whaleyfoodservice.com

WHALEY FOODSERVICE

REPAIRS
203-D CREEK RIDGE RD.
GREENSBORO, NC 27406
(336) 333-2333
FAX: (336) 333-2533
info@whaleyfoodservice.com

WHALEY FOODSERVICE

REPAIRS
335-105 SHERWEE DRIVE
RALEIGH, NC 27603
(919) 779-2266
FAX: (919) 779-2224
info@whaleyfoodservice.com

WHALEY FOODSERVICE

REPAIRS
6418-101 AMSTERDAM WAY
WILMINGTON, NC 28405
(910) 791-0000
FAX: (910) 791-6662
info@whaleyfoodservice.com

NORTH DAKOTA

GCS SERVICE INC.

MINNEAPOLIS, MN
(612) 546-4221
800-345-4221
FAX: (612) 546-4286

GENERAL PARTS, INC.

10 SOUTH 18TH STREET
FARGO, ND 58103
(701) 235-4161
(800) 279-9987
(701) 235-0539 FAX

OHIO

CERTIFIED SERVICE CENTER

890 REDNA TERRACE
CINCINNATI, OH 45215
(513) 772-6600
800-543-2060
FAX: (513) 612-6600
sbarasch@certifiedsc.com

CERTIFIED SERVICE CENTER

171J-K NORTH HAMILTON RD.
COLUMBUS, OH 43213
(614) 751-3769
(866) 862-1252
FAX: (614) 751-5792
jadkins@certifiedsc.com

CERTIFIED SERVICE CENTER

6025 N. DIXIE DRIVE
DAYTON, OH 45414
(937) 898-4040
(800) 257-2611
FAX: (937) 898-4177
dharvey@certifiedsc.com

COMMERCIAL PARTS & SVC.

OF COLUMBUS
5033 TRANSAMERICA DRIVE
COLUMBUS, OH 43228
(614) 221-0057
800-837-8327
FAX: (614) 221-3622

GCS SERVICE INC.

COLUMBUS, OH
(614) 476-3225
800-282-5406
FAX: (614) 476-1196

ELECTRICAL APPLIANCE

REPAIR SVC.
5805 VALLEY BELT ROAD
CLEVELAND, OH 44131
(216) 459-8700
800-621-8259
FAX: (216) 459-8707
tomr@electapprep.com

OKLAHOMA

HAGAR RESTAURANT EQMT.

1229 W MAIN STREET
OKLAHOMA CITY, OK 73106
(405) 235-2184
800-445-1791
FAX: (405) 236-5592

OREGON

RON'S SERVICE

16364 SW 72ND AVE
PORTLAND, OR 97224
(503) 624-0890
800-851-4118
FAX: (503) 684-6107
robinson@ronsservice.com

PENNSYLVANIA

A.I.S. COMMERCIAL PARTS & SERVICE

1816 WEST 26TH STREET
ERIE, PA 16508
(814) 456-3732
800-332-3732
FAX: (814) 452-4843
aiserie@aol.com

ELMER SCHULTZ SVC.

540 NORTH 3RD STREET
PHILADELPHIA, PA 19123
(215) 627-5400
FAX: (215) 627-5408
elmer2@erols.com

GCS SERVICE INC.

PHILADELPHIA, PA
(215) 925-6217
800-441-9115
FAX: (215) 925-6208

GCS SERVICE INC.

HARRISBURG, PA
(717) 564-3282
800-367-3225
FAX: (717) 564-9286

GCS SERVICE INC.

PITTSBURGH, PA
(412) 787-1970
800-738-1221
FAX: (412) 787-5005

K & D PARTS AND SERVICE CO.

1833-41 N CAMERON STREET
HARRISBURG, PA 17103
(717) 236-9039
800-932-0503
FAX: (717) 238-4367
kdparts-service@paonline.com

CLARK SERVICE & PARTS

306 AIRPORT DRIVE
BOX 10
SMOKETOWN, PA 17576
(717) 392-5590
(717) 392-5735

SECTION 7: JACKSON MAINTENANCE & REPAIR CENTERS

RHODE ISLAND TO WISCONSIN

RHODE ISLAND

GCS SERVICE INC.
EAST PROVIDENCE, RI
(401) 434-6803
800-462-6012
FAX: (401) 438-9400

SUPERIOR KITCHEN SERVICE INC.

669 ELMWOOD AVENUE
PROVIDENCE, RI 02907
(888) 590-1899
(401) 781-1996 FAX

SOUTH CAROLINA

AUTHORIZED APPLIANCE SERVICECENTER

1811 TAYLOR ST.
COLUMBIA, SC 29202
(803) 254-8414
FAX: (803) 254-5146

AUTHORIZED APPLIANCE SERVICECENTER

2249 AUGUSTA RD.
GREENVILLE, SC 29605
(864) 235-9616
FAX: (864) 235-9623

WHALEY FOODSERVICE REPAIRS

I 26&US1
P.O. BOX 4023
WEST COLUMBIA, SC 29170
(803) 791-4420
800-877-2662
FAX: (803) 794-4630
info@whaleyfoodservice.com

WHALEY FOODSERVICE REPAIRS

748 CONGAREE ROAD
GREENVILLE, SC 29607
(864) 234-7011
800-494-2539
FAX: (864) 234-6662
info@whaleyfoodservice.com

WHALEY FOODSERVICE REPAIRS

1406-C COMMERCE PL.
MYRTLE BEACH, SC 29577
(843) 626-1866
FAX: (843) 626-2632
info@whaleyfoodservice.com

WHALEY FOODSERVICE REPAIRS

4740-A FRANCHISE STREET
N. CHARLESTON, SC 29418
(843) 760-2110
FAX: (843) 760-2255
info@whaleyfoodservice.com

SOUTH DAKOTA

GCS SERVICE INC.

MINNEAPOLIS, MN
(612) 546-4221
800-345-4221
FAX: (612) 546-4286

GENERAL PARTS, INC.

10 SOUTH 18TH STREET
FARGO, ND 58103
(701) 235-4161
(800) 279-9987
(701) 235-0539 FAX

TENNESSEE

GCS SERVICE INC.

MEMPHIS, TN
(901) 366-4587
800-262-9155
FAX: (901) 366-4588

GCS SERVICE INC.

NASHVILLE, TN
(615) 244-8050
800-831-7174
FAX: (615) 244-8885

TEXAS

ARMSTRONG REPAIR CENTER

5110 GLENMOUNT DRIVE
HOUSTON, TX 77081
(713) 666-7100
800-392-5325
FAX: (713) 661-0520
gm@armstrongrepair.com

COMMERCIAL KITCHEN REPAIR CO.

1377 N BRAZOS
P.O BOX 831128
SAN ANTONIO, TX 78207
(210) 735-2811
800-292-2120
FAX: (210) 735-7421
brock@commercialkitchen.com

GCS SERVICE INC.

DALLAS, TX
(972) 484-2954
800-442-5026
FAX: (972) 484-2531

GCS SERVICE INC.

HOUSTON, TX
(713)785-9187
800-868-6957
FAX: (713) 785-3979

GCS/STOVE PARTS

2120 SOLANA STREET
FORT WORTH, TX 76117
(817) 831-0381
800-433-1804
FAX: (817) 834-7754
bud@stoveparts.com

UTAH

LA MONICA'S RESTAURANT EQMT. SVC.

6182 SOUTH STRATLER AVENUE
MURRAY, UT 84107
(801) 263-3221
800-527-2561
FAX: (801) 263-3229
lamonica81@aol.com

VERMONT

NORTHERN PARTS & SVC.

4874 S. CATHERINE STREET
PLATTSBURGH, NY 12901
(518) 563-3200
800-634-5005
FAX: (800) 782-5424
info@northernparts.com

GCS SERVICE INC.

CHELSEA, MA
(617)889-9393
800-225-1155
FAX: (617) 889-1222

VIRGINIA

DAUBERS, INC.

7645 DYNATECH COURT
SPINGFIELD, VA 22153
(703) 866-3600
800-554-7788
FAX: (703) 866-4071
daubers@aol.com

GCS SERVICE INC.

SILVER SPRING, MD
(301) 585-7550(DC)
(410) 792-0388(BALT)
800-638-7278
FAX: (301)495-4410

GCS SERVICE INC.

RICHMOND, VA
(804) 672-1700
800-899-5949
FAX: (804) 672-2888

GCS SERVICE INC.

VIRGINIA BEACH, VA
(757) 464-3500
800-476-4278
FAX: (757) 464-4106

WASHINGTON

GCS SERVICE INC.

SEATTLE, WA
(206) 763-0353
800-211-4274
FAX: (206) 763-5943

RESTAURANT APPLIANCE SERVICE

7219 ROOSEVELT WAY, NE
SEATTLE, WA 98115
(206) 524-8200
800-433-9390
FAX: (206) 525-2890
info@restappl.com

WEST VIRGINIA

STATEWIDE SERVICE, INC.

603 MAIN AVE.
NITRO, WV 25143
(304) 755-1811
(800) 441-9739
FAX: (304) 755-4001
sws3182@aol.com

WISCONSIN

APPLIANCE SERVICE CENTER, INC.

2439 ATWOOD AVE
MADISON, WI 53704
(608) 246-3160
800-236-7440
FAX: (608) 246-2721
ascmad@execpc.com

APPLIANCE SERVICE CENTER, INC.

6843 W. BELOIT RD.
WEST ALLIS, WI 53219
(414) 543-6460
800-236-6460
FAX: (414) 543-6480
ascmil@execpc.com

APPLIANCE SERVICE CENTER

786 MORRIS AVE
GREEN BAY, WI 54304
(920) 496-9993
800-236-0871
FAX: (920) 496-9927
ascfox@execpc.com

SECTION 7: JACKSON MAINTENANCE & REPAIR CENTERS

WISCONSIN TO WYOMING/INTERNATIONAL

GENERAL PARTS, INC.

W223 N735 SARATOGA DRIVE
WAUKESHA, WI 53186
(262) 650-6666
(800) 279-9946
(262) 650-6660 FAX

WYOMING

HAWKINS COMMERCIAL APPLIANCE SERVICE

3000 S. WYANDOT ST.
ENGLEWOOD, CO 80110
(303) 781-5548
(800) 624-2117
FAX: (303) 761-5561
johns@hawkinscommercial.com

METRO APPLIANCE SERVICE

1640 S BROADWAY
DENVER, CO 80210
(303) 778-1126
800-525-3532
FAX: (303) 778-0268
metroappls@aol.com

INTERNATIONAL

GLOBAL PARTS AND SUPPLY

7758 NW 72ND ST
MIAMI, FL 33166
(305) 885-6353

H.D. SHELDON AND CO

19 UNION SQUARE, WEST
NEW YORK, NY 10003
(212) 627-1759
(212) 924-6920

CANADA

THE GARLAND GROUP

1177 KAMATO ROAD
MISSISSAUGA, ONTARIO L4W
1X4
(905) 206-8380
SALES
(905) 624-1419
FAX: (905) 624-1851
SERVICE
800-427-6668
FAX: 800-361-7745

March 13, 2007

