

JGT/JGGT THERMOSTATICALLY CONTROLLED GRIDDLE

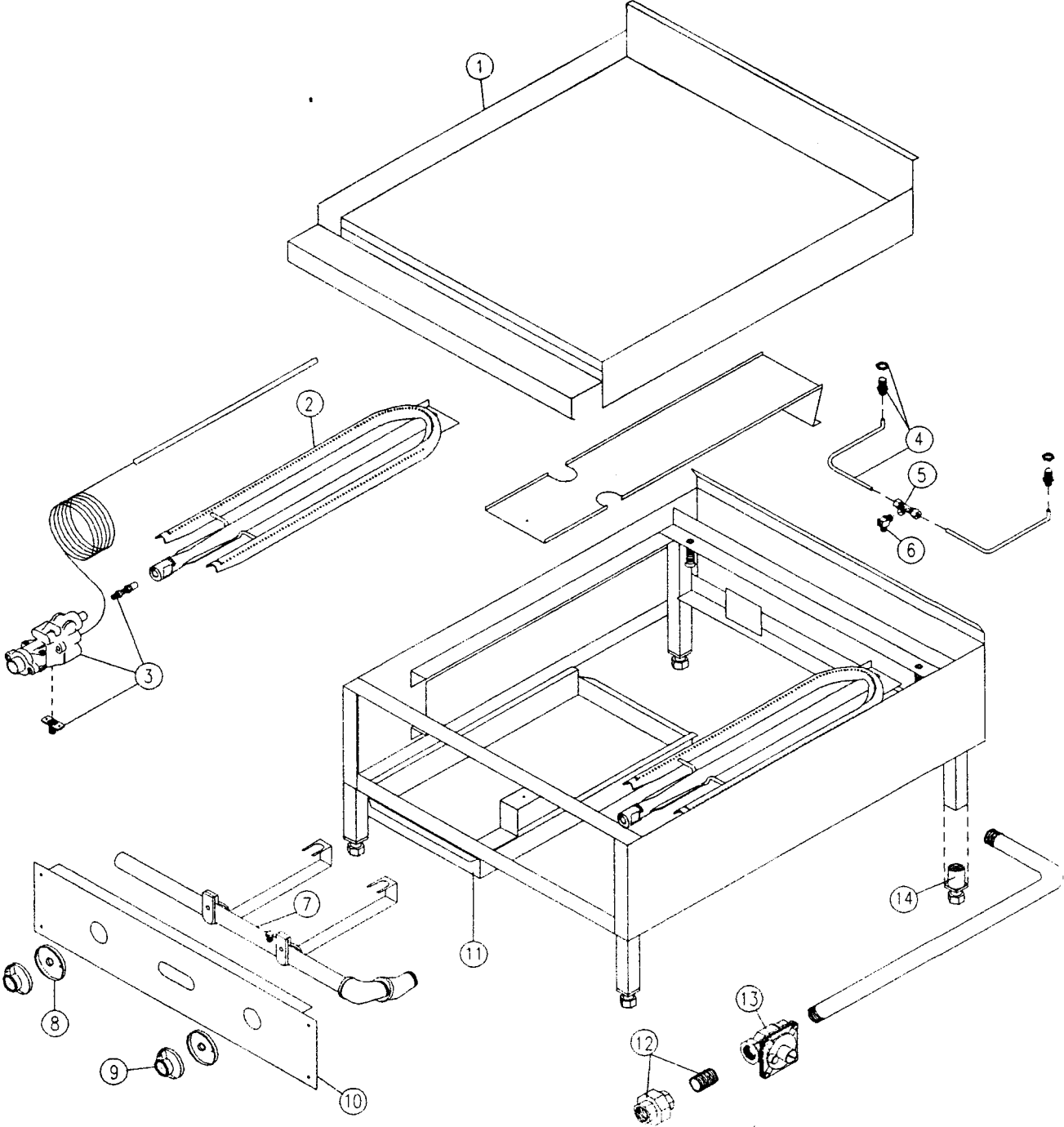

JGT/JGGT - DESCRIPTION**PART NO**

1	PLATE	LIST MODEL		
2	BURNER U , GRIDDLE W/ AIR SHUTTER 23 1/2 W/ BRACKET	120	101	000
	BURNER U , GRIDDLE W/ AIR SHUTTER 22 W/O BRACKET X 6 1/8			
	AIR SHUTTER	300	141	000
	SCREW, AIR SHUTTER 10/24 X 3/8"	340	540	000
3	THERMOSTAT. GRIDDLE	460	101	000
	FLANGED NIPPLE	460	235	000
	ORIFICE HOLDER GRIDDLE	460	234	000
	ORIFICE, #43 NAT.	460	207	000
	ORIFICE, #53 L.P.	460	217	000
	TUBING S/S 3/8" X1"	560	127	000
	SLEEVE (FERRULE), 3/8"	180	169	000
	COMP. NUT, 3/8"	180	330	000
4	PILOT, TIP S/S W/HEX NUT	460	112	000
	TUBING S/S 1/4" X 1"	560	128	000
	COMP. NUT 1/4"	180	307	000
	SLEEVE (FERRULE), 1/4-	180	322	000
5	TEE.BR 1/4" CC x 1/4" CC x 1/8" FNPT	180	429	000
6	VALVE, PILOT SINGLE	440	128	000
7	MANIFOLD	LIST MODEL		
	ELBOW, ST 3/4" 90	180	128	000
	ELBOW, ST 3/4" 45	180	140	000
	PLUG, 1/8 HX HD BLK	180	130	000
8	BEZEL	300	131	000
9	DIAL, (FOR T/STAT)	300	157	000
10	FRONT PANEL	LIST MODEL		
11	GREASE CAN 9" X 20" X 1 1/2"	150	325	000
12	UNION, 3/4"	180	148	000
	NIPPLE 3/4" CLOSED	180	132	000
13	REGULATOR, 3/4" 10.0 L.P.	460	134	000
	REGULATOR, 3/4" 5.0 NAT.	460	135	000
14	LEG, HEAVY DUTY SM PLATED	300	118	000