

# Lang

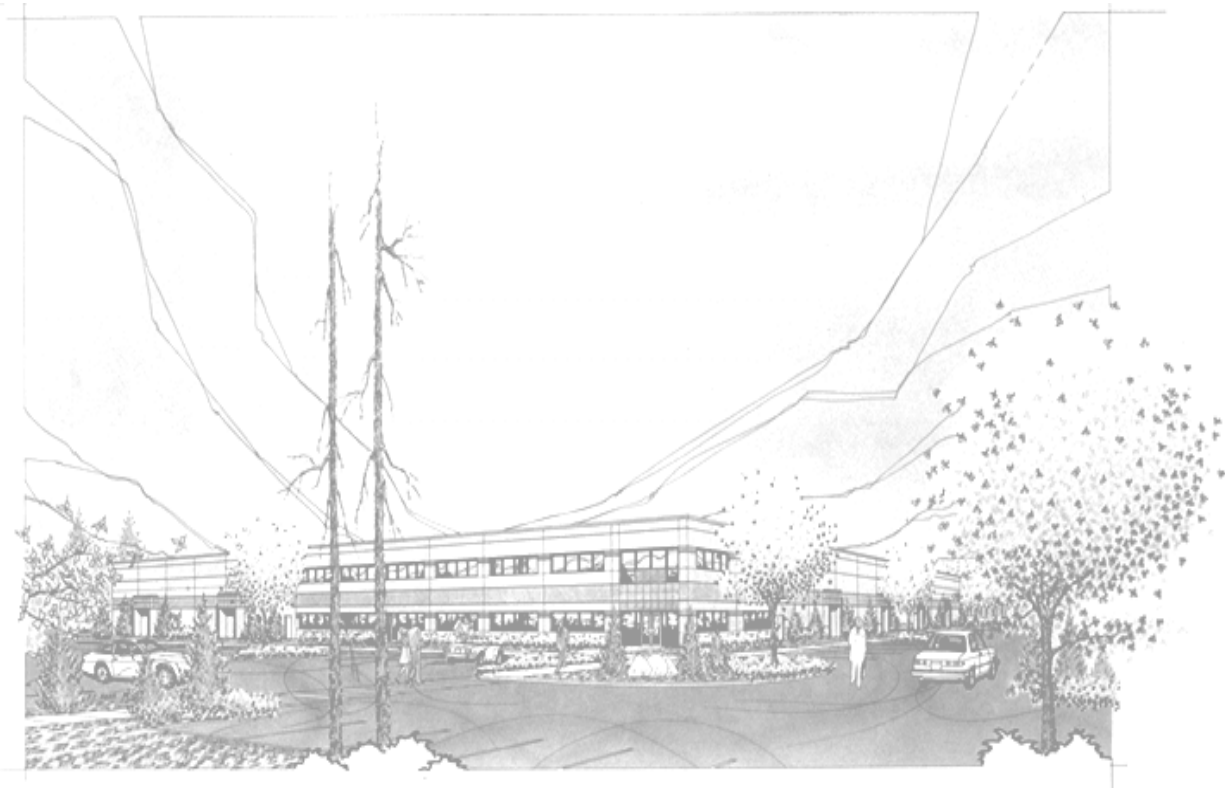

**Installation, Operation, Maintenance, & Troubleshooting**  
**Model: CLF-15-I** Electric Cruise Line Fryer  
**Serial:**



**THIS MANUAL MUST BE RETAINED FOR FUTURE REFERENCE. READ, UNDERSTAND AND FOLLOW THE INSTRUCTIONS AND WARNINGS CONTAINED IN THIS MANUAL.**

**FOR YOUR SAFETY**

**DO NOT STORE OR USE GASOLINE OR OTHER FLAMMABLE VAPORS AND LIQUIDS IN THE VICINITY OF THIS OR ANY OTHER APPLIANCE.**

**WARNING: IMPROPER INSTALLATION, ADJUSTMENT, ALTERATION, SERVICE OR MAINTENANCE CAN CAUSE PROPERTY DAMAGE, INJURY OR DEATH. READ THE INSTALLATION, OPERATING AND MAINTENANCE INSTRUCTIONS THOROUGHLY BEFORE INSTALLING OR SERVICING THIS EQUIPMENT.**

**NOTICE: THIS EQUIPMENT IS APPROVED FOR INSTALLATION ONLY ON VESSELS GREATER THAN 65 FEET IN LENGTH, IN ACCORDANCE WITH USCG REGULATIONS IN TITLE 46 CFR 110-113. ANY WIRING USED IN THE INSTALLATION OF THIS APPLIANCE MUST BE STRANDED COPPER.**

# TABLE OF CONTENTS

<b><u>CHAPTER</u></b>	<b><u>PAGE</u></b>
1. TABLE OF CONTENTS .....	3
2. READ FIRST .....	4
3. UNPACKING.....	6
4. INSTALLATION .....	7
5. INITIAL START-UP .....	8
6. OPERATION.....	9
7. CLEANING & MAINTENANCE PROCEDURES.....	10
8. TROUBLESHOOTING .....	12
9. PARTS LISTS .....	14
10. EXPLODED VIEW.....	16
11. WIRING DIAGRAMS .....	19
12. WARRANTY .....	20

**CAUTION:** THE FRYER WEIGHS 145 LBS. (65.91 KILOGRAMS). FOR SAFE HANDLING, INSTALLER SHOULD OBTAIN HELP AS NEEDED, OR EMPLOY APPROPRIATE MATERIALS HANDLING EQUIPMENT (SUCH AS A FORKLIFT, DOLLY, OR PALLET JACK) TO REMOVE THE UNIT FROM THE SKID AND MOVE IT TO THE PLACE OF INSTALLATION.



**CAUTION:** ANY STAND, COUNTER OR OTHER DEVICE ON WHICH FRYER WILL BE LOCATED MUST BE DESIGNED TO SUPPORT THE WEIGHT OF THE FRYER (145 LBS.).



**CAUTION:** SHIPPING STRAPS ARE UNDER TENSION AND CAN SNAP BACK WHEN CUT.



**DANGER:** THIS APPLIANCE MUST BE GROUNDED AT THE TERMINAL PROVIDED. FAILURE TO GROUND THE APPLIANCE COULD RESULT IN ELECTROCUTION AND DEATH.



**WARNING:** INSTALLATION OF THE UNIT MUST BE DONE BY PERSONNEL QUALIFIED TO WORK WITH ELECTRICITY. IMPROPER INSTALLATION CAN CAUSE INJURY TO PERSONNEL AND/OR DAMAGE TO EQUIPMENT. UNIT MUST BE INSTALLED IN ACCORDANCE WITH ALL APPLICABLE CODES.



**NOTICE:** The data plate is located behind the front control panel. The fryer voltage, wattage, serial number, wire size, and clearance specifications are on the data plate. This information should be carefully read and understood before proceeding with the installation.



**NOTICE:** The installation of any components such as a vent hood, grease extractors, fire extinguisher systems, must conform to their applicable National, State and locally recognized installation standards.



**CAUTION:** NEVER ENERGIZE THE HEATING ELEMENTS WITH NO OIL IN THE KETTLE OR WITH THE OIL LEVEL MORE THAN 3 INCHES FROM THE LOWER FILL LEVEL.



**CAUTION:** ALWAYS KEEP THE AREA NEAR THE APPLIANCE FREE FROM COMBUSTIBLE MATERIALS.



**CAUTION:** KEEP FLOOR IN FRONT OF EQUIPMENT CLEAN AND DRY. IF SPILLS OCCUR, CLEAN IMMEDIATELY, TO AVOID THE DANGER OF SLIPS OR FALLS.



**IMPORTANT**

**READ FIRST**

**IMPORTANT**

**WARNING:** ALWAYS TURN THE FRYER POWER SWITCH OFF BEFORE LIFTING THE HEATING ELEMENTS OUT OF THE FRYER OIL.

**WARNING:** BE SURE TO DRAIN THE OIL INTO A SUITABLE CONTAINER.

**WARNING:** KEEP WATER AND SOLUTIONS OUT OF CONTROLS. NEVER SPRAY OR HOSE CONTROL CONSOLE, ELECTRICAL CONNECTIONS, ETC.

**CAUTION:** MOST CLEANERS ARE HARMFUL TO THE SKIN, EYES, MUCOUS MEMBRANES AND CLOTHING. PRECAUTIONS SHOULD BE TAKEN TO WEAR RUBBER GLOVES, GOGGLES OR FACE SHIELD AND PROTECTIVE CLOTHING. CAREFULLY READ THE WARNING AND FOLLOW THE DIRECTIONS ON THE LABEL OF THE CLEANER TO BE USED.

**NOTICE:** Service on this, or any other, LANG appliance must be performed by qualified personnel only. Consult your authorized service station directory or call the factory at 1-800-224-LANG (5264), or [WWW.LANGWORLD.COM](http://WWW.LANGWORLD.COM) for the service station nearest you.

**WARNING:** BOTH HIGH AND LOW VOLTAGES ARE PRESENT INSIDE THIS APPLIANCE WHEN THE UNIT IS PLUGGED/WIRED INTO A LIVE RECEPTACLE. BEFORE REPLACING ANY PARTS, DISCONNECT THE UNIT FROM THE ELECTRIC POWER SUPPLY.

**CAUTION:** USE OF ANY REPLACEMENT PARTS OTHER THAN THOSE SUPPLIED BY LANG OR THEIR AUTHORIZED DISTRIBUTORS CAN CAUSE BODILY INJURY TO THE OPERATOR AND DAMAGE TO THE EQUIPMENT AND WILL VOID ALL WARRANTIES.



### **3.1 Receiving the Fryer**

Upon receipt, check for freight damage, both visible and concealed. Visible damage should be noted on the freight bill at the time of delivery and signed by the carrier's agent. Concealed loss or damage means loss or damage, which does not become apparent until the merchandise has been unpacked. If concealed loss or damage is discovered upon unpacking, make a written request for inspection by the carrier's agent within 15 days of delivery. All packing material should be kept for inspection. Do not return damaged merchandise to Lang Manufacturing Company. File your claim with the carrier.

### **3.2 Location**

Prior to un-crating, move the fryer as near its intended location as practical. The crating will help protect the unit from the physical damage normally associated with moving it through hallways and doorways.

### **3.3 Un-crating**

The fryer will arrive completely assembled inside a wood frame covered by cardboard box and strapped to a skid. **Remove the cardboard cover, cut the straps and remove the wood frame.**

**CAUTION:** FRYER WEIGHS 145 LBS (65.91 kilograms). FOR SAFE HANDLING, INSTALLER SHOULD OBTAIN HELP AS NEEDED, OR EMPLOY APPROPRIATE MATERIALS HANDLING EQUIPMENT (SUCH AS A FORKLIFT, DOLLY, OR PALLET JACK) TO REMOVE THE UNIT FROM THE SKID AND MOVE IT TO THE PLACE OF INSTALLATION.



**CAUTION:** ANY STAND, COUNTER OR OTHER DEVICE ON WHICH FRYER WILL BE LOCATED MUST BE DESIGNED TO SUPPORT THE WEIGHT OF THE FRYER (145 LBS.).



**CAUTION:** SHIPPING STRAPS ARE UNDER TENSION AND CAN SNAP BACK WHEN CUT.



Remove fryer from skid and place in intended location.

# INSTALLATION

**DANGER:** THIS APPLIANCE MUST BE GROUNDED AT THE TERMINAL PROVIDED. FAILURE TO GROUND THE APPLIANCE COULD RESULT IN ELECTROCUTION AND DEATH.



**WARNING:** INSTALLATION OF THE UNIT MUST BE DONE BY PERSONNEL QUALIFIED TO WORK WITH ELECTRICITY. IMPROPER INSTALLATION CAN CAUSE INJURY TO PERSONNEL AND/OR DAMAGE TO EQUIPMENT. UNIT MUST BE INSTALLED IN ACCORDANCE WITH ALL APPLICABLE CODES.



**NOTICE:** The data plate is located behind the front control panel. The fryer voltage, wattage, serial number, wire size, and clearance specifications are on the data plate. This information should be carefully read and understood before proceeding with the installation.



**NOTICE:** The installation of any components such as a vent hood, grease extractors, fire extinguisher systems, must conform to their applicable National, State and locally recognized installation standards.



## 4.1 Electrical Connection

Electrical service may be made through a standard 1¼-inch conduit. A hole should be cut out in one of two locations, the first is behind the unit on the right side (if looking from the back). It should be made 3” from the side and 3” from the bottom. The second location is on the bottom back right corner (if looking from the back). It should be made 2” from the side, and 3” from the back. Check the National Electrical Code for fuse or circuit breaker requirements.

## 4.2 Fryer Voltage

The Lang Model CLF-15-I can be operated on 240 Volts.

# INITIAL START UP

## **5.1 PRE-POWER ON**

### **Boil Out Fryer**

Ensure the elements are lowered into the fry pot. Fill the fry pot with a mixture of Vinegar and water (1:10 mix). Fill until the Vinegar and water level is maintained between the lower and upper fill marks. Heat to 200°F and let stand for 30 minutes. After 30 minutes drain water and vinegar mix (see operation section for instructions). Be sure to wipe out and dry fry pot to remove any water spots.

### **Fill levels**

There are two fill marks on the sides of the fryer kettle. The lower level indicates the fill mark with the elements out, the upper level indicates the fill mark when the elements are lowered. Fill and maintain the oil level between the upper and lower levels.

**CAUTION:** NEVER ENERGIZE THE HEATING ELEMENTS WITH NO OIL IN THE KETTLE OR WITH THE OIL LEVEL MORE THAN 3 INCHES FROM THE LOWER FILL LEVEL.



**CAUTION:** ALWAYS KEEP THE AREA NEAR THE APPLIANCE FREE FROM COMBUSTIBLE MATERIALS.



**CAUTION:** KEEP FLOOR IN FRONT OF EQUIPMENT CLEAN AND DRY. IF SPILLS OCCUR, CLEAN IMMEDIATELY, TO AVOID THE DANGER OF SLIPS OR FALLS.



## **6.1 Controls**

The power switch, located on the control box at the front of the fryer, energizes the control circuits. When this switch is on, the “power” pilot lamp will be illuminated.

Turn the temperature selector dial to the desired temperature setting. This control is located next to the power switch. The “heat” pilot lamp will illuminate indicating power is applied to the heating elements.

The lamp marked “overtemp” will illuminate if the oil reaches an over-temperature condition. The over-temperature thermostat shuts off the fryer before the oil reaches a dangerously high temperature.

## **6.2 Heating Elements**

The elements may be raised and locked in the up position. The latch is located on the rear top surface of the fryer and may be activated by lifting the handle at either side of the fryer.

## **6.3 Draining the Fryer Oil**

**WARNING:** ALWAYS TURN THE FRYER POWER SWITCH OFF BEFORE LIFTING THE HEATING ELEMENTS OUT OF THE FRYER OIL.



**WARNING:** BE SURE TO DRAIN THE OIL INTO A SUITABLE CONTAINER.



A drain valve is provided inside the lower cabinet door.

To drain the cooking oil remove the steel cap from the drain pipe located at the bottom, lower, front left corner of the fryer. Connect a drain pipe extension to the drainpipe. Pull the lever located in the front bottom left corner of the fryer.

# MAINTENANCE & CLEANING

## 7.1 Daily Cleaning

**WARNING: KEEP WATER AND SOLUTIONS OUT OF CONTROLS. NEVER SPRAY OR HOSE CONTROL CONSOLE, ELECTRICAL CONNECTIONS, ETC.**



**CAUTION: MOST CLEANERS ARE HARMFUL TO THE SKIN, EYES, MUCOUS MEMBRANES AND CLOTHING. PRECAUTIONS SHOULD BE TAKEN TO WEAR RUBBER GLOVES, GOGGLES OR FACE SHIELD AND PROTECTIVE CLOTHING. CAREFULLY READ THE WARNING AND FOLLOW THE DIRECTIONS ON THE LABEL OF THE CLEANER TO BE USED.**



It is recommended the fryer oil be kept as clean as possible by straining regularly (several times a day) and filtering daily. This will lengthen the life of your oil and improve the performance of the fryer.

## 7.2 Daily Severe Duty Cleaning

1. Turn power switch off.
2. Remove the baskets, let baskets drain and then set aside.
3. Raise heating elements out of oil and lock in up position.
4. Remove cap from oil drainpipe on bottom of fryer.
5. Place a suitable container under drainpipe.
6. Pull drain valve lever forward to open drain valve.
7. Remove loose food particles from heating units with spatula and wire brush.
8. Flush out scrapings and sediment with a small quantity of hot oil, and allow to drain thoroughly.
9. Close drain valve and fill with a commercial fryer cleaning agent or soapy solution of non-corrosive grease dissolving cleaner.
10. Lower heating elements and set selector switch to 250°F (be sure to read and follow cleaner manufactures instructions) and boil solution for 15 to 20 minutes.
11. Turn power switch off.
12. Raise heating elements and lock in up position, then drain solution from well. Refill with water and add 1/2 cup of white vinegar to neutralize alkaline left by soap. Lower heating elements and bring solution to a boil and let stand for a few minutes.
13. Turn power switch off.
14. Raise heating elements and lock in up position and drain well and rinse with clear, hot water. Dry well and heating units thoroughly, and close drain valve.
15. Refill fryer with oil, and lower heating elements slowly.
16. Operate fryer as normal.

## 7.3 Over-Temperature Protection

The over-temperature thermostat located next to the left heating element provides protection in case of malfunction of the main temperature control. It will open both the “control contactor” and the “safety contactor” removing all power from the heating elements.

## MAINTENANCE & CLEANING CONT'D

### **7.4 Thermostat Bulb Check**

The two thermostat bulbs, (temperature control thermostat bulb and over-temp thermostat bulb), are all connected to the fryer heating elements. The brackets that hold these bulbs in place should be checked on a regular basis for tightness. If any of the brackets/bulbs become loose, the brackets that hold the bulbs should be tightened right away.

### **7.5 Component Access**

All maintenance may be done from the front. Opening the front by removing 4 bolts gains access to all circuitry, with the exception of the thermostat, which is located on the top where the thermostat knob is located. To gain access to the safety thermostat, the thermostat, and element terminals remove the 4 screws from the front of the access cover located above and to the rear of the oil well.

# TROUBLESHOOTING

## 9.1 Symptoms

What follows is a chart of Symptoms and Possible Causes to aid in diagnosing faults with the oven.

Refer to the Symptoms column to locate the type of failure then to the Possible Cause for the items to be checked.

To test for a possible cause, refer to the TEST section and locate the Possible Cause then refer to test to identify test procedures.

<b>SYMPTOM</b>	<b>POSSIBLE CAUSE</b>
Power indicator is not lit.	<ul style="list-style-type: none"><li>• No power to cord outlet</li><li>• Fryer unplugged from outlet</li><li>• Failed power cord or plug</li><li>• Failed power switch</li><li>• Failed pilot light</li></ul>
Fryer will not heat	<ul style="list-style-type: none"><li>• Failed element</li><li>• Power switch is not ON</li><li>• Failed contactor</li><li>• Failed thermostat</li><li>• Failed transformer</li><li>• Tripped over temperature thermostat</li></ul>
Product burning	<ul style="list-style-type: none"><li>• Product is cooked too long</li><li>• Failed thermostat</li><li>• Failed contactor</li></ul>
Product under done	<ul style="list-style-type: none"><li>• Failed temperature sensor</li><li>• Failed circuit board</li><li>• Failed temperature selector</li></ul>
Heat indicator is not lit	<ul style="list-style-type: none"><li>• Failed heat light</li><li>• Failed thermostat</li><li>• Failed contactor</li></ul>
Overtemp. indicator is not lit	<ul style="list-style-type: none"><li>• Failed indicator light</li><li>• Normal</li></ul>
Overtemp. indicator is lit	<ul style="list-style-type: none"><li>• Overtemp. thermostat tripped</li><li>• Failed indicator light</li><li>• Failed overtemp. thermostat</li></ul>

# TROUBLESHOOTING CONT'D

## 9.2 TESTS

### NOTICE:

Service on this, or any other, LANG appliance must be performed by qualified personnel only. Consult your authorized service station directory or call the factory at 1-800-224-LANG (5264), or WWW.LANGWORLD.COM for the service station nearest you.



### WARNING:

**BOTH HIGH AND LOW VOLTAGES ARE PRESENT INSIDE THIS APPLIANCE WHEN THE UNIT IS PLUGGED/WIRED INTO A LIVE RECEPTACLE. BEFORE REPLACING ANY PARTS, DISCONNECT THE UNIT FROM THE ELECTRIC POWER SUPPLY.**



If an item on the list is followed by an asterisk (\*), the work should be done by a factory authorized service representative.

Possible Cause	TEST
Product is cooked too long	<ul style="list-style-type: none"> <li>• No test available, operational condition</li> </ul>
Failed thermostat	<ul style="list-style-type: none"> <li>• Check poles on thermostat for continuity</li> </ul>
Failed element	<ul style="list-style-type: none"> <li>• Remove the wires and check for continuity across the element</li> </ul>
Failed heat contactor	<ul style="list-style-type: none"> <li>• Remove the wires from the contactor coil and check for continuity across the contactor coil connection</li> <li>• Ensure the contactor moveable points move freely up and down</li> <li>• Check for 24 volts at the contactor coil when the computer is running*</li> </ul>
Failed or disconnected safety thermostat	<ul style="list-style-type: none"> <li>• Check across the thermostat connectors for continuity</li> </ul>

### CAUTION:

**USE OF ANY REPLACEMENT PARTS OTHER THAN THOSE SUPPLIED BY LANG OR THEIR AUTHORIZED DISTRIBUTORS CAN CAUSE BODILY INJURY TO THE OPERATOR AND DAMAGE TO THE EQUIPMENT AND WILL VOID ALL WARRANTIES.**



# PARTS LIST

## CLF-15-I

Item #	Description	Part Number	Qty
1	Body and Bucket Assembly	C28-001-CL	1
2	Front	C28-503-CL	1
3	Drain Cap	C28-505-CL	1
4	Fryer Drain Cover	C28-108-1-CL	1
5	Threaded Pipe	70302-25	1
6	90° Elbow	70304-06	1
7	Ball Valve	70400-01	1
8	Drain Valve Bracket Assembly	C28-545-CL	1
9	Drain Valve Rod	C28-547-CL	1
10	Shoulder Screw, 5/16 X 1/2, 1/4-20 SKT	20106-01	1
11	Lift Handle	C28-163	1
12	Smother Cover	C28-205-CL	1
13	Head Pivot Support	C28-136-CL	1
14	Stanchion Trimlock	C28-540-CL	2
15	Head Pivot	C28-137-CL	1
16	3/32 X 1-1/2 Stainless Steel Cotter Pin	71801-03	2
17	3 Feet of Black Rubber-Lock	71100-03	1
18	Wire Cover	C28-508-2-CL	1
19	Body Back	C28-506-CL	1
20	Large 2 Pole Terminal Block, 175 Amp	30500-11	2
21	2 Position Rotary Switch	30304-30	1
22	Contact Block	30304-31	1
23	3 Pole Contactor, 35A, 208/240 V	30700-05	2
24	15 Amp Fuse (ABC-15)	30900-01	2
25	15 Amp Fuse Holder	30901-02	2
28	Thermostat, Fixed Temp.	30401-13	1
29	Pilot Light, 250 V	31601-01	3
30	Thermostat, Adjustable	30402-12	1

## PARTS LIST CONT'D

### CLF-15-I

31	Knob Assembly	70701-06	1
32	Harness	C28-560-CL	1
33	Wireway Top Trimlock	C28-542-CL	4
34	Wireway Side Trimlock	C28-537-CL	4
35	Electrical Mount	C28-527-CL	1
36	Lower Element Clip	C28-164-CL	7
37	Upper Element Clip	C28-165-CL	4
38	Bulb Spacer	C28-166-CL	2
39	Large Bulb Clip	C28-167-CL	4
40	Small Bulb Clip	C28-168-CL	2
41	Limitstat Bulb Spacer	C28-168-1-CL	2
42	Element Washer	C28-160-CL	6
43	Over Temperature Thermostat Insulator	C28-131-2	1
44	Over Temperature Thermostat Spacer	C28-131-1-CL	1
45	Element Clamp	C28-161	1
46	Element, 240 V, 4 KW	11110-44	3
47	5/8-18 Stainless Steel Jam Nut	20303-14	6
48	Basket Hanger Assembly	C28-531-CL	1
49	Head Wrap	C28-130-2-CL	1
50	Fryer Basket	50600-09	2

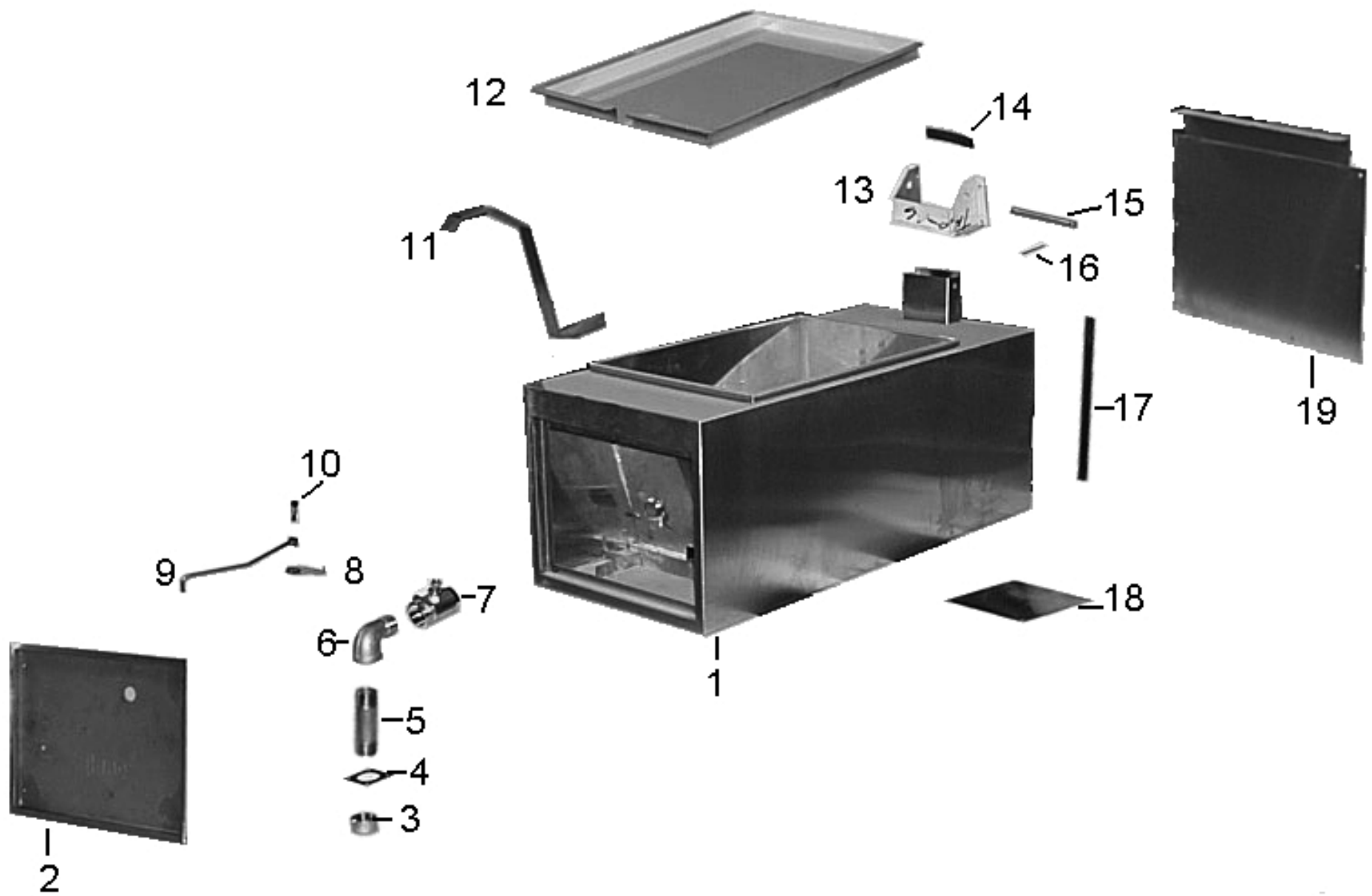

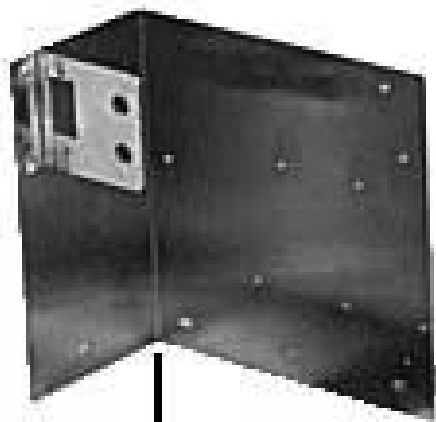

35

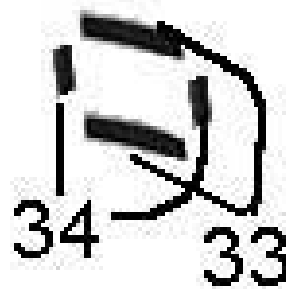

34

33

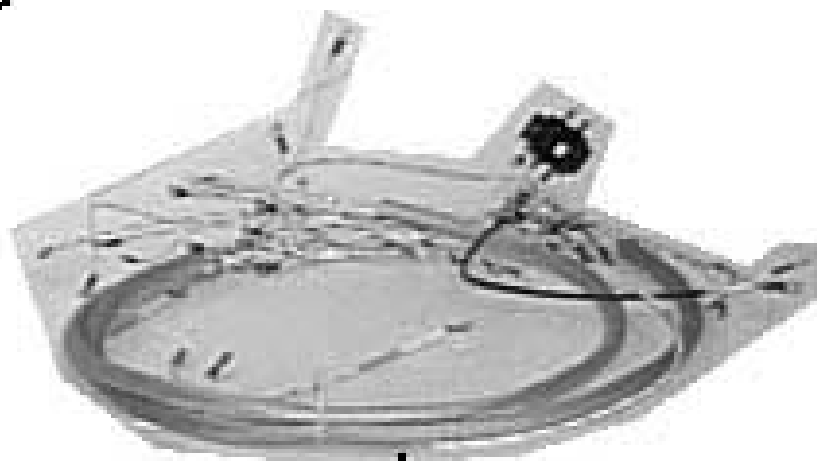

32

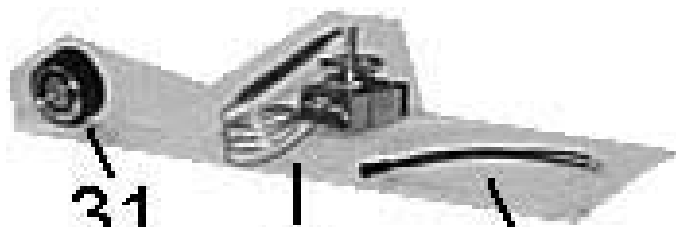

31

30

29

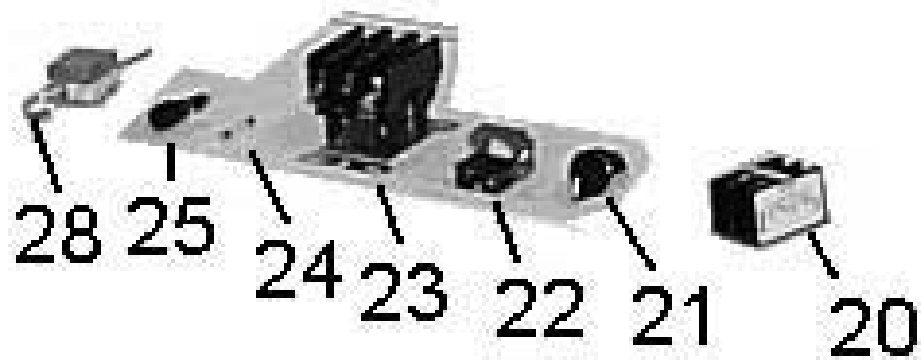

28

25

24

23

22

21

20

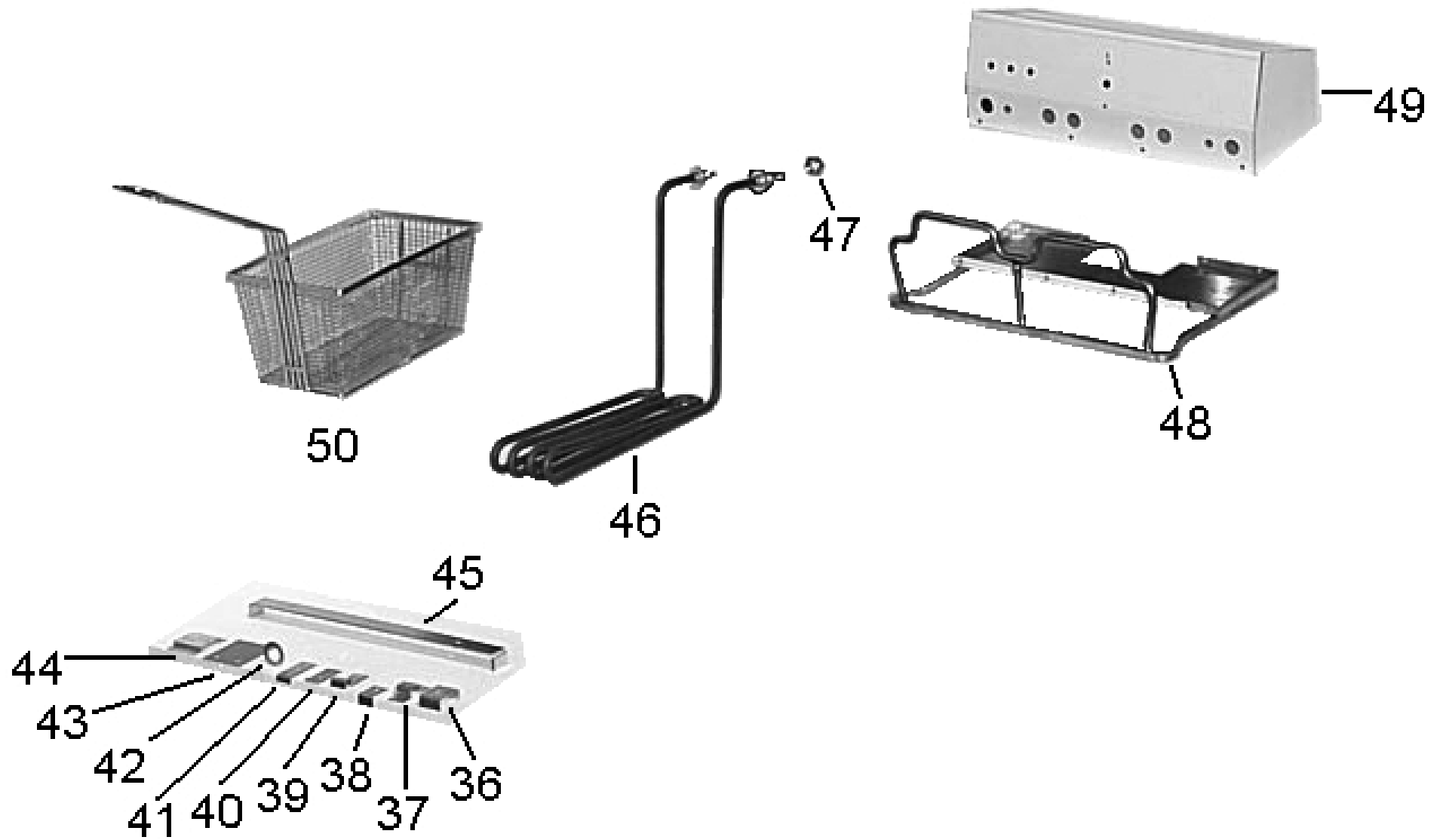

# WIRING DIAGRAM

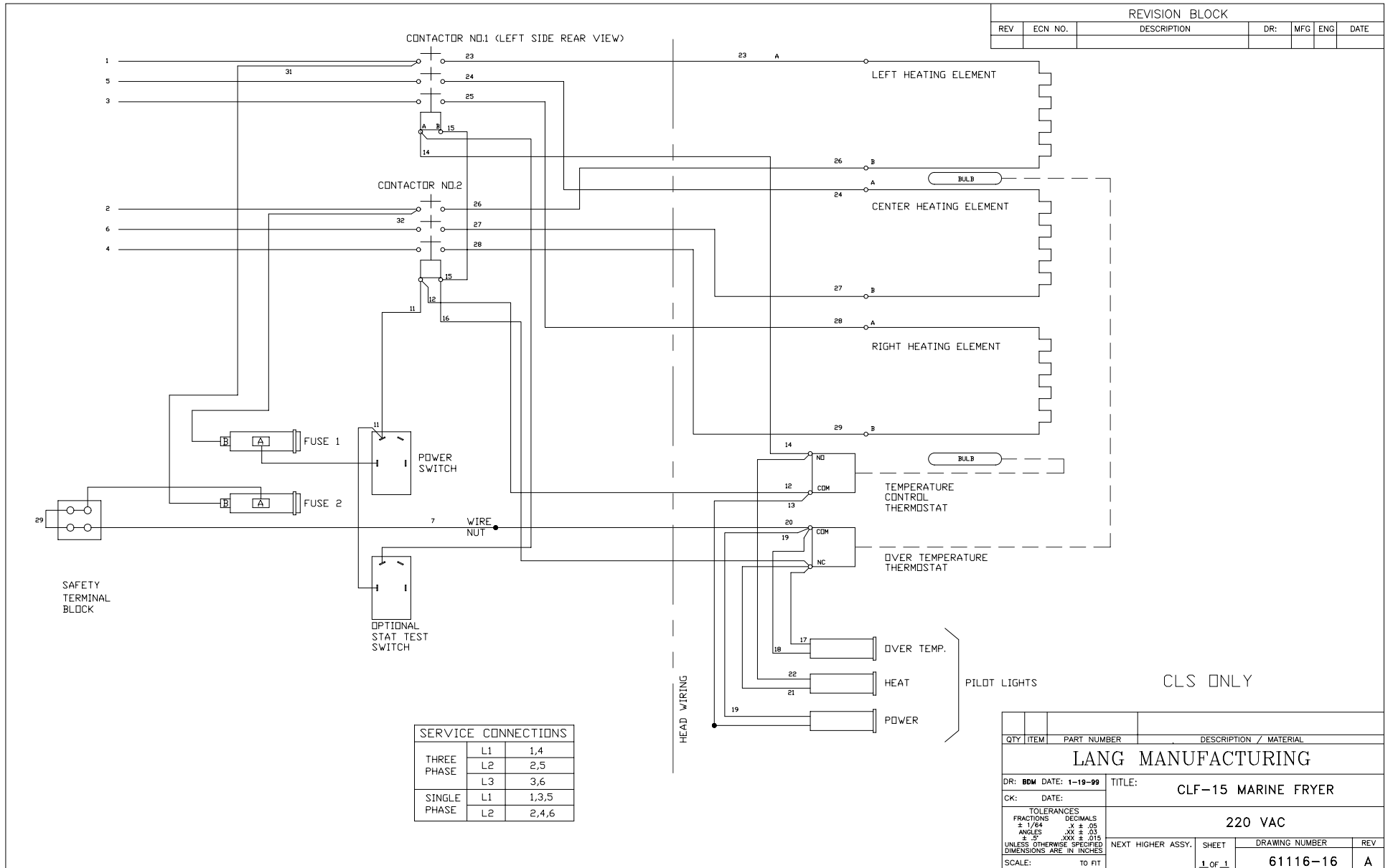

## ***Lang Manufacturing Limited Warranty to Cruise Line Purchasers***

Lang Manufacturing Equipment (“Lang Equipment”) has been skillfully manufactured, carefully inspected and packaged to meet rigid standards of excellence. Lang warrants its Equipment to be free from defects in material and material-related workmanship for (13) thirteen consecutive months from the date of initial shipboard installation or (18) eighteen consecutive months from date of initial factory shipment, whichever ever comes first. The aforementioned warranty statement is subject to the following conditions and limitations.

**I.** This warranty is limited to the provision of replacement components for Product sold by Lang to a joiner company for installation aboard a cruise ship, or a cruise ship company for installation aboard its own ship. The provision of replacement components to affect Product repairs will be on a no-charge basis during the term of the warranty. Replacement components will be sent to the address required within 48 hours of Lang receiving written notification of the description of the defect and the model and serial number of the Product affected by the repair.

Quartz elements are warranted for ninety (90) days from the date of installation.

**II.** Damage during shipment is to be reported to the carrier, is not covered under this warranty, and is the sole responsibility of purchaser/user.

**III.** Replacement components will be shipped F.O.B. factory with freight prepaid. Replacement component damage related to shipment is not covered under this warranty.

**IV.** This warranty does not cover consumable parts such as quartz elements, and does not cover defects caused by improper installation, abuse, careless operation, or improper maintenance of Product.

**V.** All warranties are conditioned upon Lang’s receipt of written notice of any defect prior to the end of the applicable warranty period.

**VI.** THIS WARRANTY IS EXCLUSIVE AND IS IN LIEU OF ALL OTHER WARRANTIES, EXPRESSED OR IMPLIED, INCLUDING ANY IMPLIED WARRANTY OF MERCHANTABILITY OR FITNESS FOR A PARTICULAR PURPOSE, EACH OF WHICH IS HEREBY EXPRESSLY DISCLAIMED. THE REMEDIES DESCRIBED ABOVE ARE EXCLUSIVE AND IN NO EVENT SHALL LANG BE LIABLE FOR SPECIAL, CONSEQUENTIAL OR INCIDENTAL DAMAGES FOR THE BREACH OR DELAY IN PERFORMANCE OF THIS WARRANTY.

**VII.** Lang Equipment is for cruise line use only. If sold as a component of another (OEM) manufacturer’s equipment, or if used as a consumer product, such Equipment is sold AS IS and without any warranty.