

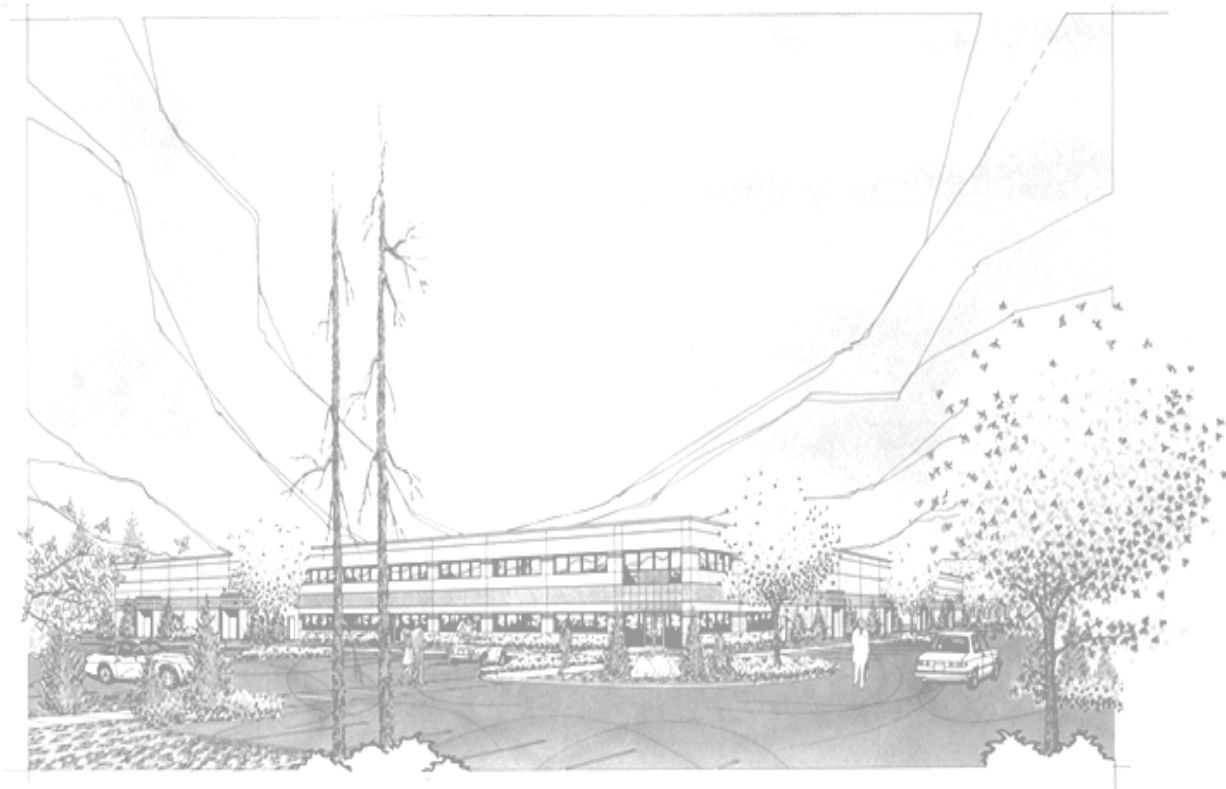





**Installation, Operation, Maintenance, & Troubleshooting**  
**Model: CLGPB-48-E** Electric Cruise Line Griddle, Pickle Barrel  
**Serial:**



**THIS MANUAL MUST BE RETAINED FOR FUTURE REFERENCE. READ, UNDERSTAND AND FOLLOW THE INSTRUCTIONS AND WARNINGS CONTAINED IN THIS MANUAL.**

**FOR YOUR SAFETY**  
**DO NOT STORE OR USE GASOLINE OR OTHER FLAMMABLE VAPORS AND LIQUIDS IN THE VICINITY OF THIS OR ANY OTHER APPLIANCE.**

**WARNING: IMPROPER INSTALLATION, ADJUSTMENT, ALTERATION, SERVICE OR MAINTENANCE CAN CAUSE PROPERTY DAMAGE, INJURY OR DEATH. READ THE INSTALLATION, OPERATING AND MAINTENANCE INSTRUCTIONS THOROUGHLY BEFORE INSTALLING OR SERVICING THIS EQUIPMENT.**

|                       |   |   |
|-----------------------|---|---|
| <b><u>DANGER</u></b>  | POTENTIALLY HAZARDOUS SITUATION WHICH, IF NOT AVOIDED, COULD RESULT IN DEATH.                   |    |
| <b><u>WARNING</u></b> | POTENTIALLY HAZARDOUS SITUATION WHICH, IF NOT AVOIDED, COULD RESULT IN DEATH OR SERIOUS INJURY. |  |
| <b><u>CAUTION</u></b> | POTENTIALLY HAZARDOUS SITUATION WHICH, IF NOT AVOIDED, MAY RESULT IN MINOR OR MODERATE INJURY.  |  |
| <b><u>NOTICE</u></b>  | Helpful operation and installation instructions and tips are present.                           |  |

# TABLE OF CONTENTS

| <b>CHAPTER</b>             | <b>PAGE</b> |
|----------------------------|-------------|
| 1. TABLE OF CONTENTS ..... | 3           |
| 2. READ FIRST .....        | 4           |
| 3. UNPACKING .....         | 5           |
| 4. INSTALLATION .....      | 6           |
| 5. INITIAL START-UP .....  | 7           |
| 6. OPERATION .....         | 8           |
| 7. CLEANING.....           | 9           |
| 8. TROUBLESHOOTING .....   | 10          |
| 9. PARTS LIST .....        | 11          |
| 10. EXPLODED VIEWS .....   | 12          |
| 11. WIRING DIAGRAM.....    | 15          |

|                       |   |
|-----------------------|---|
| <b><u>CAUTION</u></b> | GRIDDLE WEIGHS 515 lbs (234 kg). FOR SAFE HANDLING, INSTALLER SHOULD OBTAIN HELP AS NEEDED, OR EMPLOY APPROPRIATE MATERIALS HANDLING EQUIPMENT (SUCH AS A FORKLIFT, DOLLY, OR PALLET JACK) TO REMOVE THE UNIT FROM THE SKID AND MOVE IT TO THE PLACE OF INSTALLATION.                         |
| <b><u>CAUTION</u></b> | ANY STAND, COUNTER OR OTHER DEVICE ON WHICH GRIDDLE WILL BE LOCATED MUST BE DESIGNED TO SUPPORT THE WEIGHT OF THE GRIDDLE.  |
| <b><u>CAUTION</u></b> | SHIPPING STRAPS ARE UNDER TENSION AND CAN SNAP BACK WHEN CUT.   |
| <b><u>DANGER</u></b>  | <b>THIS APPLIANCE MUST BE GROUNDED AT THE TERMINAL PROVIDED. FAILURE TO GROUND THE APPLIANCE COULD RESULT IN ELECTROCUTION AND DEATH.</b>   |
| <b><u>WARNING</u></b> | <b>INSTALLATION OF THE UNIT MUST BE DONE BY PERSONNEL QUALIFIED TO WORK WITH ELECTRICITY. IMPROPER INSTALLATION CAN CAUSE INJURY TO PERSONNEL AND/OR DAMAGE TO EQUIPMENT. UNIT MUST BE INSTALLED IN ACCORDANCE WITH ALL APPLICABLE CODES.</b>   |
| <b><u>NOTICE</u></b>  | The data plate is located behind the access panel in the back of the griddle. The griddle voltage, wattage, serial number, wire size, and clearance specifications are on the data plate. This information should be carefully read and understood before proceeding with the installation.   |
| <b><u>NOTICE</u></b>  | The installation of any components such as a vent hood, grease extractors, fire extinguisher systems, must conform to their applicable National, State and locally recognized installation standards.   |
| <b><u>CAUTION</u></b> | ALWAYS KEEP THE AREA NEAR THE APPLIANCE FREE FROM COMBUSTIBLE MATERIALS.  |
| <b><u>CAUTION</u></b> | KEEP FLOOR IN FRONT OF EQUIPMENT CLEAN AND DRY. IF SPILLS OCCUR, CLEAN IMMEDIATELY, TO AVOID THE DANGER OF SLIPS OR FALLS.  |
| <b><u>WARNING</u></b> | <b>KEEP WATER AND SOLUTIONS OUT OF CONTROLS. NEVER SPRAY OR HOSE CONTROL CONSOLE, ELECTRICAL CONNECTIONS, ETC.</b>  |
| <b><u>CAUTION</u></b> | MOST CLEANERS ARE HARMFUL TO THE SKIN, EYES, MUCOUS MEMBRANES AND CLOTHING. PRECAUTIONS SHOULD BE TAKEN TO WEAR RUBBER GLOVES, GOGGLES OR FACE SHIELD AND PROTECTIVE CLOTHING. CAREFULLY READ THE WARNING AND FOLLOW THE DIRECTIONS ON THE LABEL OF THE CLEANER TO BE USED.                   |
| <b><u>NOTICE</u></b>  | Service on this, or any other, LANG appliance must be performed by qualified personnel only. Consult your authorized service station directory or call the factory at 1-800-224-LANG (5264), or <a href="http://WWW.LANGWORLD.COM">WWW.LANGWORLD.COM</a> for the service station nearest you. |
| <b><u>WARNING</u></b> | <b>BOTH HIGH AND LOW VOLTAGES ARE PRESENT INSIDE THIS APPLIANCE WHEN THE UNIT IS PLUGGED/WIRED INTO A LIVE RECEPTACLE. BEFORE REPLACING ANY PARTS, DISCONNECT THE UNIT FROM THE ELECTRIC POWER SUPPLY.</b>  |
| <b><u>CAUTION</u></b> | USE OF ANY REPLACEMENT PARTS OTHER THAN THOSE SUPPLIED BY LANG OR THEIR AUTHORIZED DISTRIBUTORS CAN CAUSE BODILY INJURY TO THE OPERATOR AND DAMAGE TO THE EQUIPMENT AND WILL VOID ALL WARRANTIES.   |



### **3.1 Receiving the Griddle**

Upon receipt, check for freight damage, both visible and concealed. Visible damage should be noted on the freight bill at the time of delivery and signed by the carrier's agent. Concealed loss or damage means loss or damage which does not become apparent until the merchandise has been unpacked. If concealed loss or damage is discovered upon unpacking, make a written request for inspection by the carrier's agent within 15 days of delivery. All packing material should be kept for inspection. Do not return damaged merchandise to Lang Manufacturing Company. File your claim with the carrier.



### **3.2 Location**

Prior to un-crating, move the griddle as near its intended location as practical. The crating will help protect the unit from the physical damage normally associated with moving it through hallways and doorways.

### **3.3 Un-crating**

The griddle will arrive completely assembled inside a wood frame covered by cardboard box and strapped to a skid. **Remove the cardboard cover, cut the straps and remove the wood frame.**

Remove griddle from skid and place in intended location.

- |                       |  |   |
|-----------------------|--|---|
| <b><u>CAUTION</u></b> | <b>GRIDDLE WEIGHS 515 lbs (234 kg). FOR SAFE HANDLING, INSTALLER SHOULD OBTAIN HELP AS NEEDED, OR EMPLOY APPROPRIATE MATERIALS HANDLING EQUIPMENT (SUCH AS A FORKLIFT, DOLLY, OR PALLET JACK) TO REMOVE THE UNIT FROM THE SKID AND MOVE IT TO THE PLACE OF INSTALLATION.</b> |  |
| <b><u>CAUTION</u></b> | <b>ANY STAND, COUNTER OR OTHER DEVICE ON WHICH GRIDDLE WILL BE LOCATED MUST BE DESIGNED TO SUPPORT THE WEIGHT OF THE GRIDDLE.</b>  |  |
| <b><u>CAUTION</u></b> | <b>SHIPPING STRAPS ARE UNDER TENSION AND CAN SNAP BACK WHEN CUT.</b>   |  |

# INSTALLATION

|                       |   |
|-----------------------|---|
| <b><u>DANGER</u></b>  | <b>THIS APPLIANCE MUST BE GROUNDED AT THE TERMINAL PROVIDED. FAILURE TO GROUND THE APPLIANCE COULD RESULT IN ELECTROCUTION AND DEATH.</b>   |
| <b><u>WARNING</u></b> | <b>INSTALLATION OF THE UNIT MUST BE DONE BY PERSONNEL QUALIFIED TO WORK WITH ELECTRICITY. IMPROPER INSTALLATION CAN CAUSE INJURY TO PERSONNEL AND/OR DAMAGE TO EQUIPMENT. UNIT MUST BE INSTALLED IN ACCORDANCE WITH ALL APPLICABLE CODES.</b>   |
| <b><u>NOTICE</u></b>  | The data plate is located behind the access panel in the back of the griddle. The griddle voltage, wattage, serial number, wire size, and clearance specifications are on the data plate. This information should be carefully read and understood before proceeding with the installation. |
| <b><u>NOTICE</u></b>  | The installation of any components such as a vent hood, grease extractors, fire extinguisher systems, must conform to their applicable National, State and locally recognized installation standards.   |



## **4.1 Electrical Connection**

There is one power supply connection on the griddle. Refer to the power supply chart on the bottom of this page for proper power supply size.

The installer will provide a knockout location in the rear or the bottom of the griddle.

Use a supply wire suitable for at least 90° C.

## **4.2 Griddle Voltage**

The model CLGPB-48-E griddle is shipped from the factory wired for 220 volts.

## **4.3 Phasing**

All griddles are shipped from the factory set up for a **three-phase** service.

| GRIDDLE SPECIFICATIONS |          |                       |        |        |          |
|------------------------|----------|-----------------------|--------|--------|----------|
| MODEL NUMBER           | TOTAL kW | NOMINAL AMPS PER LINE |        |        | WEIGHT   |
|                        |          | THREE PHASE           |        |        |          |
|                        |          | 220 VOLT              |        |        |          |
|                        |          | LINE 1                | LINE 2 | LINE 3 |          |
| CLGPB-48-E             | 29.6     | 89.0                  | 58.0   | 89.0   | 515 lbs. |

## **5.1 Initial Start Up**

Before starting the griddle for the first time, clean the griddle body and cooking surface with a mild soap and water solution then rinse with clear water and dry.

Set the temperature dials to 200 degrees.

Heat the griddle at 200 degrees for 2 hours to evaporate any moisture that may be in the elements.

After 2 hours at 200 degrees, proceed with "SEASON THE GRILL SURFACE".

## **5.2 Season the Grill**

The cooking surface must be "seasoned" in order to reduce product sticking.

To season, heat the griddle to 250 degrees.

Once at 250 degrees, coat the cooking surface with a non-salted vegetable oil.

Allow the griddle to stand at 250 degrees until the cooking surface looks dry then coat it again.

Heat the griddle to 350 degrees and repeat the procedure.

The griddle may emit a small amount of smoke as the cooking surface passes the 350° point. Do not be alarmed as oils associated with the manufacturing process may cause smoke and will stop when the griddle reaches 350 degrees.

|                       |   |
|-----------------------|---|
| <b><u>CAUTION</u></b> | <b>ALWAYS KEEP THE AREA NEAR THE APPLIANCE FREE FROM COMBUSTIBLE MATERIALS.</b>   |
| <b><u>CAUTION</u></b> | <b>KEEP FLOOR IN FRONT OF EQUIPMENT CLEAN AND DRY. IF SPILLS OCCUR, CLEAN IMMEDIATELY, TO AVOID THE DANGER OF SLIPS OR FALLS.</b> |



## **6.1 Setting the Temperature**

If different temperature settings across the same griddle are to be used, select one side of the griddle and run that at the lowest temperature. Adjoining sections should be set at progressively higher temperatures. Do not try to run end sections hot and center sections cool.

## **6.2 Loading the Grill**

An understanding of how the griddle sections are controlled will be a valuable aid in loading your griddle.

A thermostat independently controls each 12-inch section. The sensor for each is mounted under the griddle plate in the center of each cooking section.

If product is loaded directly over the temperature sensor, that section will turn on and the element will heat the entire cooking section. If the product is loaded to the side, front or back of the temperature sensor, the controller will react to the temperature change of the entire section instead of just one product.

During slow periods minimal loads, do not load directly over the temperature sensors as this will unnecessarily turn the elements on and over heat the remainder of the section not being utilized.

During busy periods, a systematic approach should be utilized in loading the griddle. Load the entire section from rear to front and continue cooking to the next section if necessary.

Turn the product and continue cooking until it has reached its desired degree of doneness.

Remove the product from the griddle.

When reloading the griddle, first use the griddle surface on which a previous load was not placed. This will ensure the proper griddle temperature.



**WARNING**

**KEEP WATER AND SOLUTIONS OUT OF CONTROLS. NEVER SPRAY OR HOSE CONTROL CONSOLE, ELECTRICAL CONNECTIONS, ETC.**

**CAUTION**

**MOST CLEANERS ARE HARMFUL TO THE SKIN, EYES, MUCOUS MEMBRANES AND CLOTHING. PRECAUTIONS SHOULD BE TAKEN TO WEAR RUBBER GLOVES, GOGGLES OR FACE SHIELD AND PROTECTIVE CLOTHING. CAREFULLY READ THE WARNING AND FOLLOW THE DIRECTIONS ON THE LABEL OF THE CLEANER TO BE USED.**



## **7.1 Daily Cleaning (after each meal)**

Keep the griddle surface clean. After each cooking load, scrape the griddle surface with the grooved griddle cleaning tool to remove any carbonized grease.

The griddle surface should be cleaned and re-seasoned. Use a griddle stone, griddle pad, or liquid cleaner. Rub with the grain of the metal, being careful not to scrape the splashguard.

Clean the exterior of the appliance with a hot water and chlorine solution to maintain a gleaming appearance.

Be sure to rinse thoroughly and coat the cooking surface with a thin film of oil to prevent rusting.

Re-season the griddle plate after each cleaning (refer to page 8).

## 9.1 Symptoms

What follows is a chart of Symptoms and Possible Causes to aid in diagnosing faults with the oven.

Refer to the Symptoms column to locate the type of failure then to the Possible Cause for the items to be checked.

To test for a possible cause, refer to the TEST section and locate the Possible Cause then refer to test to identify test procedures.

| SYMPTOM               | POSSIBLE CAUSE  |
|-----------------------|---|
| Griddle will not heat | <ul style="list-style-type: none"> <li>• Failed element</li> <li>• Failed thermostat</li> <li>• No power to cord outlet</li> <li>• Open wire</li> </ul> |
| Product burning       | <ul style="list-style-type: none"> <li>• Product is cooked too long</li> <li>• Failed thermostat</li> </ul>   |
| Product under done    | <ul style="list-style-type: none"> <li>• Failed thermostat</li> </ul>   |

### **NOTICE**

**Service on this, or any other, LANG appliance must be performed by qualified personnel only. Consult your authorized service station directory or call the factory at 1-800-224-LANG (5264), or [WWW.LANGWORLD.COM](http://WWW.LANGWORLD.COM) for the service station nearest you.**



### **WARNING**

**BOTH HIGH AND LOW VOLTAGES ARE PRESENT INSIDE THIS APPLIANCE WHEN THE UNIT IS PLUGGED/WIRED INTO A LIVE RECEPTACLE. BEFORE REPLACING ANY PARTS, DISCONNECT THE UNIT FROM THE ELECTRIC POWER SUPPLY.**



## 9.2 TESTS

If an item on the list is followed by an asterisk (\*), the work should be done by a factory authorized service representative.

| Possible Cause             | TEST  |
|----------------------------|---|
| Product is cooked too long | <ul style="list-style-type: none"> <li>• No test available, operational condition</li> </ul>                            |
| Failed thermostat          | <ul style="list-style-type: none"> <li>• Check thermostat for continuity, or that it is cycling on &amp; off</li> </ul> |
| Failed element             | <ul style="list-style-type: none"> <li>• Remove the wires and check for proper resistance across the element</li> </ul> |

### **CAUTION**

**USE OF ANY REPLACEMENT PARTS OTHER THAN THOSE SUPPLIED BY LANG OR THEIR AUTHORIZED DISTRIBUTORS CAN CAUSE BODILY INJURY TO THE OPERATOR AND DAMAGE TO THE EQUIPMENT AND WILL VOID ALL WARRANTIES.**



## PARTS LIST

| Item # | Description                           | Part Number |
|--------|---------------------------------------|-------------|
| 1      | Body Assembly, 4 Foot, Pickle Barrel  | LGCL-219-41 |
| 2      | Plate Assembly, 4 Foot, Pickle Barrel | LGCL-723-41 |
| 3      | Control Panel Assembly, Pickle Barrel | LGCL-725-41 |
| 4      | Bottom Snout Cover                    | LGCL-416    |
| 5      | Supply Wire Baffle                    | LGCL-227    |
| 6      | Rear Cover                            | LGCL-507    |
| 7      | Knob, Thermostat                      | 70701-28    |
| 8      | Griddle Stand Assembly                | LGCL-710-4  |
| 9      | Screw, 10-32 X .5, S/S Hex Head Cap   | 20111-09    |
| 10     | Element, 208/240 Volt, 5991 Watts     | 11030-29    |
| 11     | Nut, 10-32, Hex Head                  | 20303-02    |
| 12     | Element Pan, Zig-Zag                  | LGCL-439    |
| 13     | Element Pan, Insulation               | XL-424      |
| 14     | Element Pan                           | LGCL-434    |
| 15     | Washer, Stainless Steel, Flat         | 20203-05    |
| 16     | Nut, Hex, Stainless Steel, 5/16-18    | 20303-07    |
| 17     | Thermostat Holder                     | LGCL-504    |
| 18     | Thermostat, Griddle, 550°F            | 30402-07    |
| 19     | Terminal Block, 2 Pole,               | 30500-11    |
| 20     | Wire Harness                          | LGCL-586    |
| 21     | Ground Harness                        | LGCL-770    |
| 22     | Hotel Pan, Pickle Barrel              | 73800-01    |
| 23     | Element, 208V, 1491 Watts             | 11030-30    |

# EXPLODED VIEW

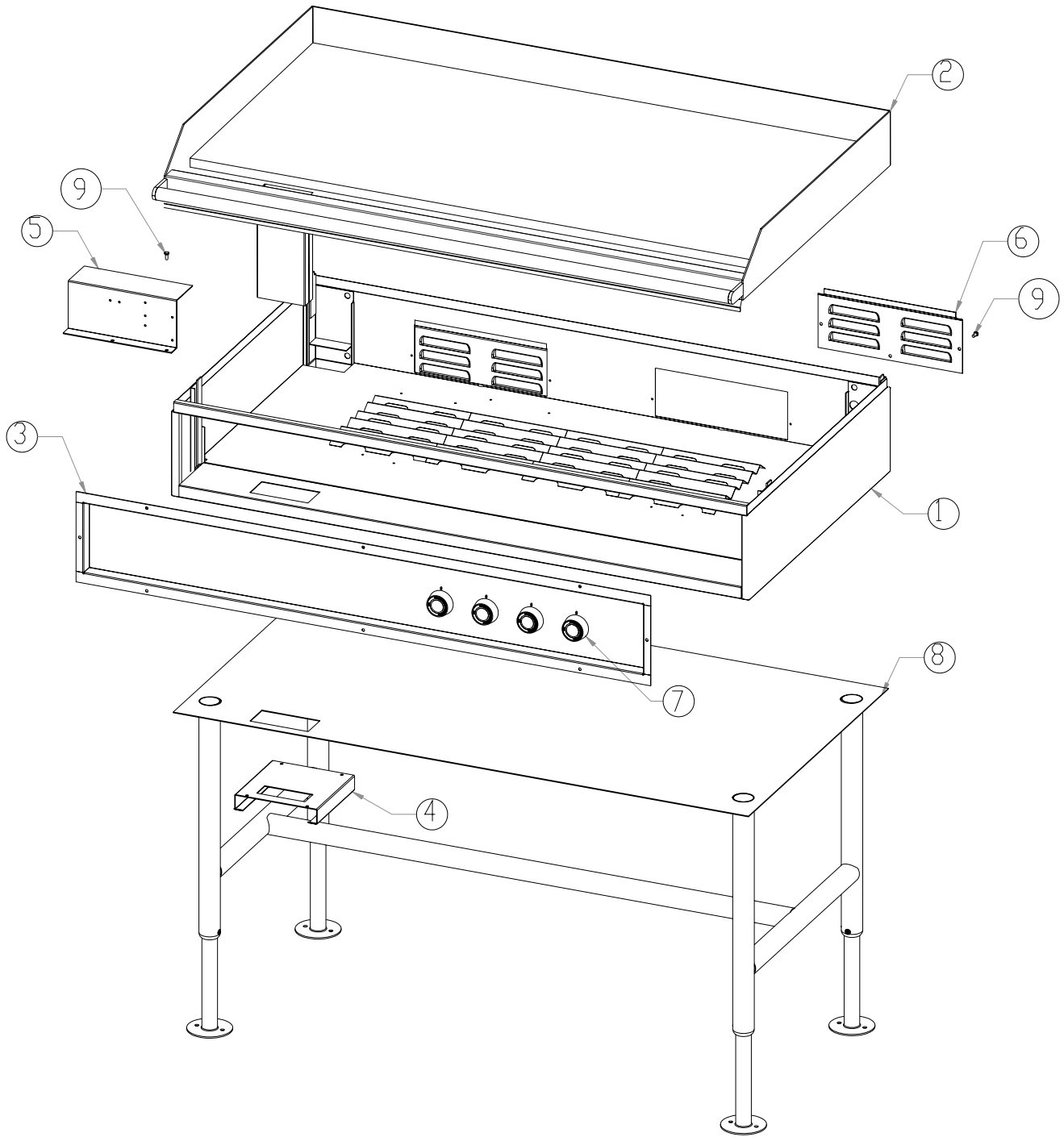

**EXPLODED VIEW CONT'D**

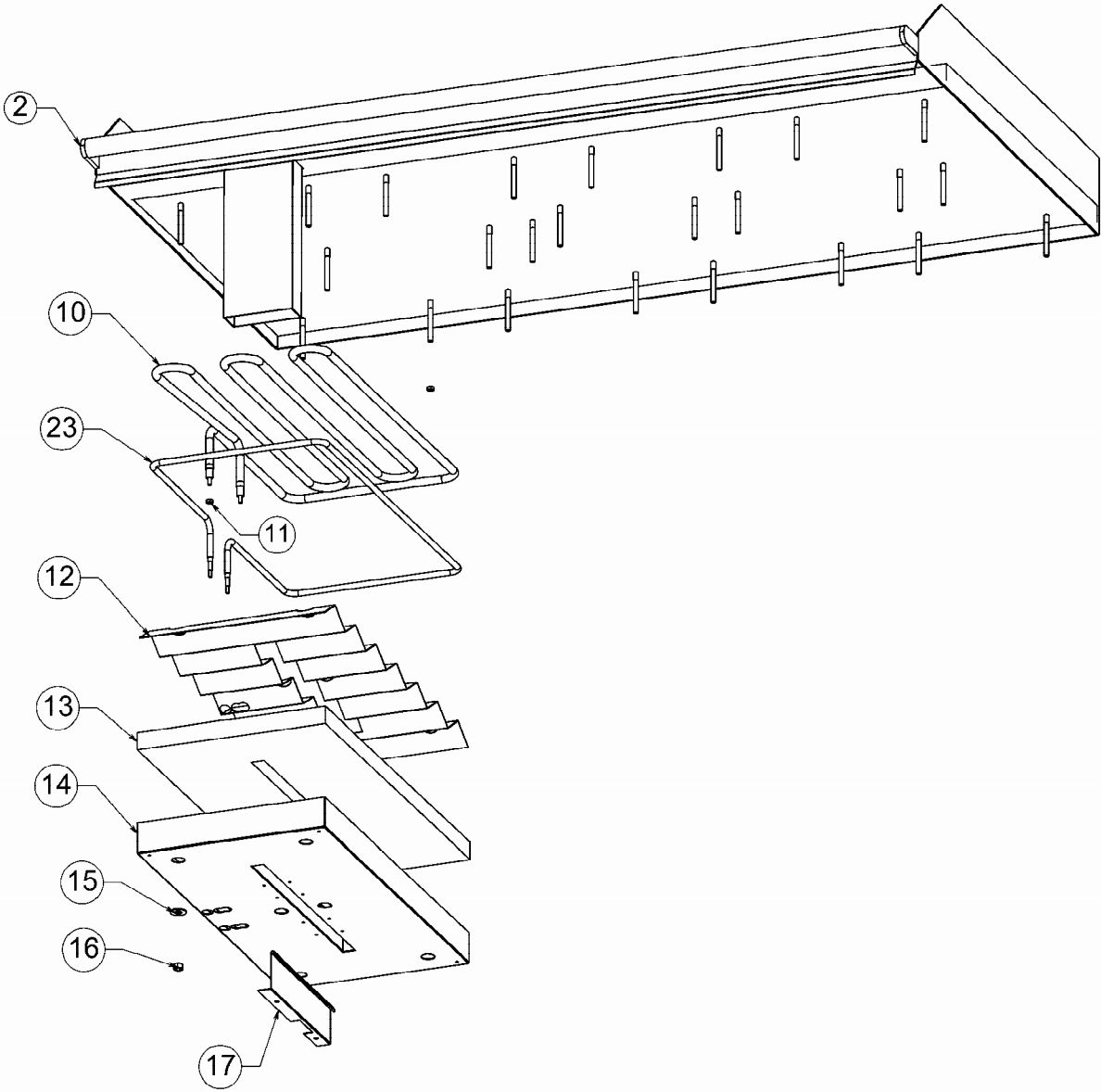

**EXPLODED VIEW CONT'D**

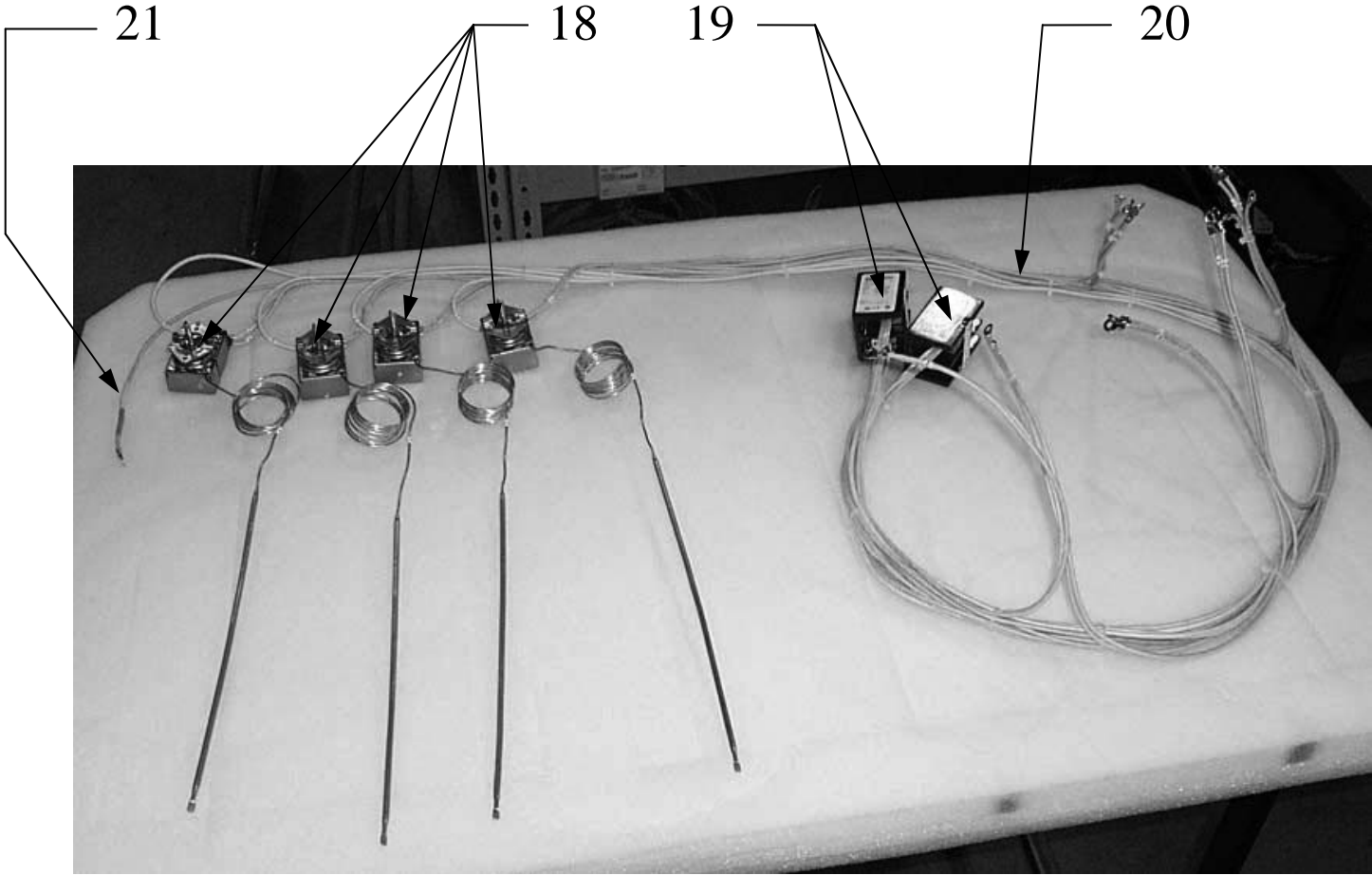

# WIRING DIAGRAM

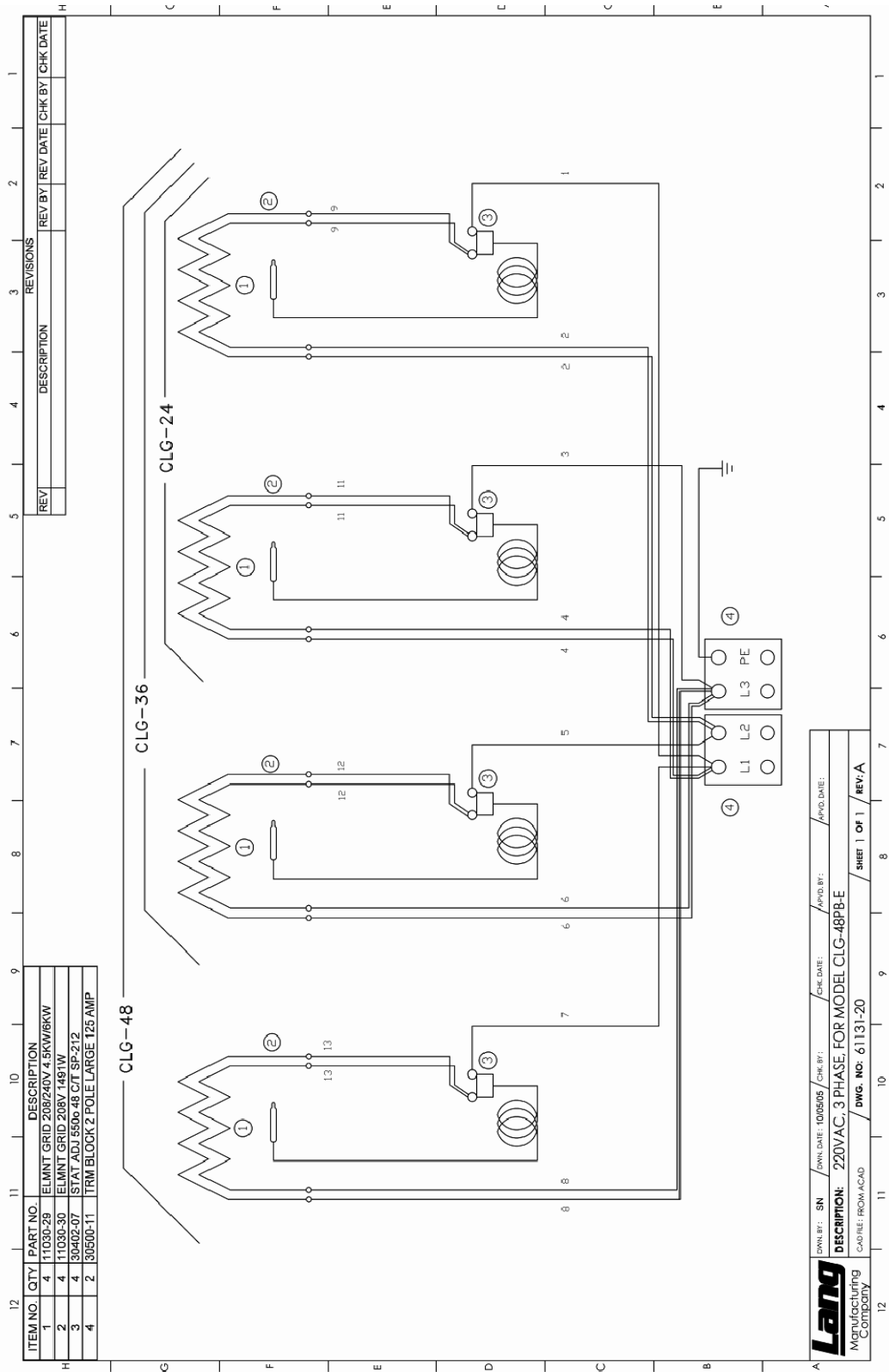

| ITEM NO. | QTY | PART NO. | DESCRIPTION                    |
|----------|-----|----------|--------------------------------|
| 1        | 4   | 11030-29 | ELMNT GRID 203/240V 4.5KW/6KW  |
| 2        | 4   | 11030-30 | ELMNT GRID 203V 1481W          |
| 3        | 4   | 30402-07 | STAT ADJ L550v-48 CTF SP-212   |
| 4        | 2   | 30500-11 | TRM BLOCK 2 POLE LARGE 125 AMP |

| REV | DESCRIPTION | REV BY | REV DATE | CHK BY | CHK DATE |
|-----|-------------|--------|----------|--------|----------|
|     |             |        |          |        |          |

**Lang** Manufacturing Company  
 DWN BY: SN / JWN DATE: 10/05/05 / CHK BY: / APD DATE: /  
**DESCRIPTION: 220VAC, 3 PHASE, FOR MODEL CLG-48PB-E**  
 CAUSE: FROM ACAD / DWG. NO: 61131-20 / SHEET 1 OF 1 / REV-A

THIS PAGE IS  
INTENTIONALLY  
LEFT BLANK