

# Lang



## Installation, Operation, Maintenance, & Troubleshooting

**Model: CLR36R-H-S** Electric Cruise Line Hot Top Range with an Overhead Switchbox

**Serial:**

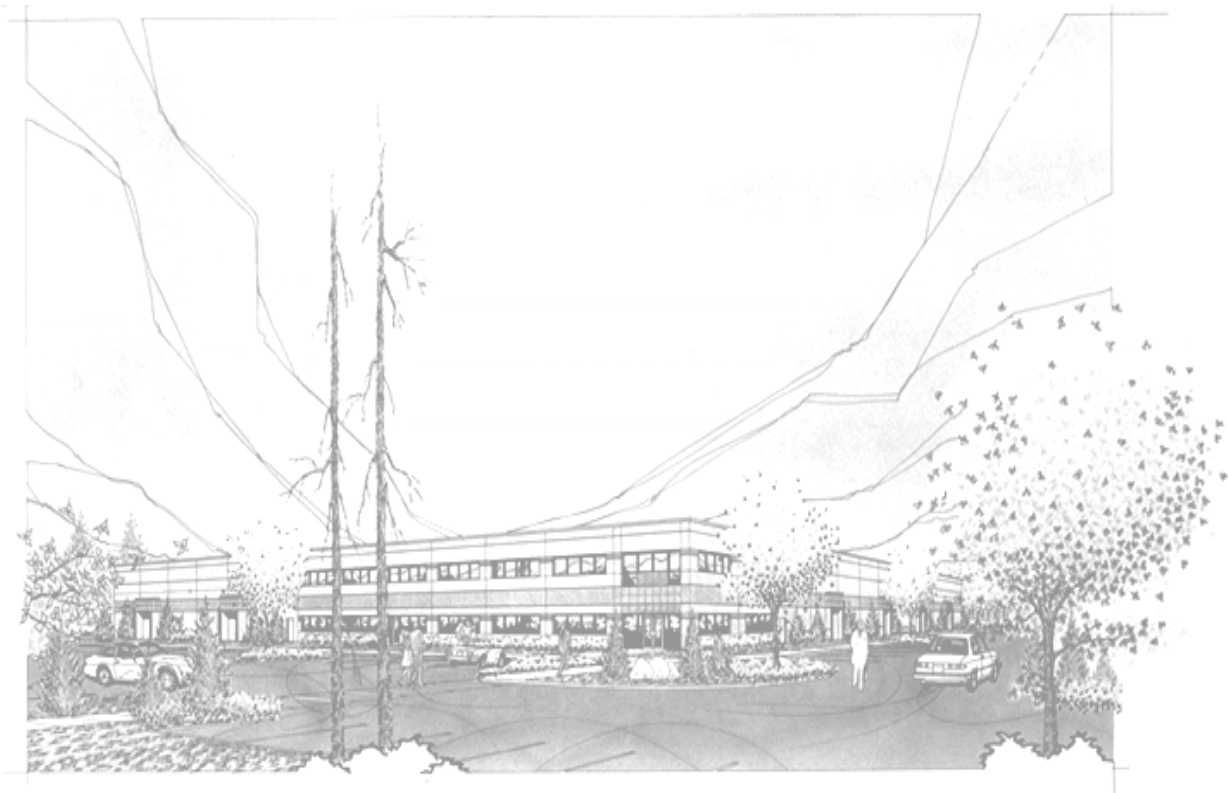

**THIS MANUAL MUST BE RETAINED FOR FUTURE REFERENCE. READ, UNDERSTAND AND FOLLOW THE INSTRUCTIONS AND WARNINGS CONTAINED IN THIS MANUAL.**

**FOR YOUR SAFETY**

**DO NOT STORE OR USE GASOLINE OR OTHER FLAMMABLE VAPORS AND LIQUIDS IN THE VICINITY OF THIS OR ANY OTHER APPLIANCE.**

**WARNING: IMPROPER INSTALLATION, ADJUSTMENT, ALTERATION, SERVICE OR MAINTENANCE CAN CAUSE PROPERTY DAMAGE, INJURY OR DEATH. READ THE INSTALLATION, OPERATING AND MAINTENANCE INSTRUCTIONS THOROUGHLY BEFORE INSTALLING OR SERVICING THIS EQUIPMENT.**

**NOTICE: THIS EQUIPMENT IS APPROVED FOR INSTALLATION ONLY ON VESSELS GREATER THAN 65 FEET IN LENGTH, IN ACCORDANCE WITH USCG REGULATIONS IN TITLE 46 CFR 110-113. ANY WIRING USED IN THE INSTALLATION OF THIS APPLIANCE MUST BE STRANDED COPPER.**

# TABLE OF CONTENTS

<b><u>CHAPTER</u></b>	<b><u>PAGE</u></b>
1. TABLE OF CONTENTS.....	3
2. READ FIRST.....	4
3. UNPACKING.....	6
4. INSTALLATION.....	7
5. INITIAL START-UP.....	8
6. OPERATION.....	9
7. CLEANING PROCEDURES.....	10
8. TROUBLESHOOTING.....	11
9. PARTS LISTS.....	13
10. EXPLODED VIEWS.....	15
11. WIRING DIAGRAMS.....	21
12. WARRANTY.....	22

**CAUTION:** THE RANGE WEIGHS 600 LBS. (272.16 KILOGRAMS). FOR SAFE HANDLING, INSTALLER SHOULD OBTAIN HELP AS NEEDED, OR EMPLOY APPROPRIATE MATERIALS HANDLING EQUIPMENT (SUCH AS A FORKLIFT, DOLLY, OR PALLET JACK) TO REMOVE THE UNIT FROM THE SKID AND MOVE IT TO THE PLACE OF INSTALLATION.



**CAUTION:** ANY STAND, COUNTER OR OTHER DEVICE ON WHICH RANGE WILL BE LOCATED MUST BE DESIGNED TO SUPPORT THE WEIGHT OF THE RANGE (600 LBS.).



**DANGER:** THIS APPLIANCE MUST BE GROUNDED AT THE TERMINAL PROVIDED. FAILURE TO GROUND THE APPLIANCE COULD RESULT IN ELECTROCUTION AND DEATH.



**WARNING:** INSTALLATION OF THE UNIT MUST BE DONE BY PERSONNEL QUALIFIED TO WORK WITH ELECTRICITY. IMPROPER INSTALLATION CAN CAUSE INJURY TO PERSONNEL AND/OR DAMAGE TO EQUIPMENT. UNIT MUST BE INSTALLED IN ACCORDANCE WITH ALL APPLICABLE CODES.



**NOTICE:** The data plate is located behind the access cover to the right of the oven door. The range voltage, wattage, serial number, wire size, and clearance specifications are on the data plate. This information should be carefully read and understood before proceeding with the installation.



**NOTICE:** The installation of any components such as a vent hood, grease extractors, fire extinguisher systems, must conform to their applicable National, State and locally recognized installation standards.



**CAUTION:** ALWAYS KEEP THE AREA NEAR THE APPLIANCE FREE FROM COMBUSTIBLE MATERIALS.



**CAUTION:** KEEP FLOOR IN FRONT OF EQUIPMENT CLEAN AND DRY. IF SPILLS OCCUR, CLEAN IMMEDIATELY, TO AVOID THE DANGER OF SLIPS OR FALLS.



**WARNING:** KEEP WATER AND SOLUTIONS OUT OF CONTROLS. NEVER SPRAY OR HOSE CONTROL CONSOLE, ELECTRICAL CONNECTIONS, ETC.



**CAUTION:** MOST CLEANERS ARE HARMFUL TO THE SKIN, EYES, MUCOUS MEMBRANES AND CLOTHING. PRECAUTIONS SHOULD BE TAKEN TO WEAR RUBBER GLOVES, GOGGLES OR FACE SHIELD AND PROTECTIVE CLOTHING. CAREFULLY READ THE WARNING AND FOLLOW THE DIRECTIONS ON THE LABEL OF THE CLEANER TO BE USED.



**NOTICE:** Service on this, or any other, LANG appliance must be performed by qualified personnel only. Consult your authorized service station directory or call the factory at 1-800-224-LANG (5264), or WWW.LANGWORLD.COM for the service station nearest you.



**WARNING:** BOTH HIGH AND LOW VOLTAGES ARE PRESENT INSIDE THIS APPLIANCE WHEN THE UNIT IS PLUGGED/WIRED INTO A LIVE RECEPTACLE. BEFORE REPLACING ANY PARTS, DISCONNECT THE UNIT FROM THE ELECTRIC POWER SUPPLY.



**CAUTION:** USE OF ANY REPLACEMENT PARTS OTHER THAN THOSE SUPPLIED BY LANG OR THEIR AUTHORIZED DISTRIBUTORS CAN CAUSE BODILY INJURY TO THE OPERATOR AND DAMAGE TO THE EQUIPMENT AND WILL VOID ALL WARRANTIES.



### **3.1 Receiving the Range**

Upon receipt, check for freight damage, both visible and concealed. Visible damage should be noted on the freight bill at the time of delivery and signed by the carrier's agent. Concealed loss or damage means loss or damage, which does not become apparent until the merchandise has been unpacked. If concealed loss or damage is discovered upon unpacking, make a written request for inspection by the carrier's agent within 15 days of delivery. All packing material should be kept for inspection. Do not return damaged merchandise to Lang Manufacturing Company. File your claim with the carrier.

### **3.2 Location**

Prior to un-crating, move the range as near its intended location as practical. The crating will help protect the unit from the physical damage normally associated with moving it through hallways and doorways.

### **3.3 Un-crating**

Uncrate range as close to installation location as possible. The range is packaged on a pallet, wrapped in plastic to protect the unit from moisture and surrounded by a wooden frame. Remove the wood crating carefully. Improper use of tools can result in damage to the equipment. Remove and discard the plastic wrap. Desiccant bags on top of the range should also be discarded. Protective paper on top of the range may be left until the installation is complete.

The range is raised on blocks to enable ease of handling when removing from pallet with forklift or straps. Use extreme care regardless of method used and be aware of gravity center, especially with banks of multiple units.

PLEASE NOTE:

Legs, manuals, racks, rack slides, griddle cleaning tools, fryer smother covers and remote overhead switch boxes, where applicable, are packed inside the oven cavity and should remain there until the unit is at the final installation location.

Desiccant bags have been placed inside electrical cavity and must be removed before operation.

**CAUTION:** RANGE WEIGHS 600 LBS (272.16 kilograms). FOR SAFE HANDLING, INSTALLER SHOULD OBTAIN HELP AS NEEDED, OR EMPLOY APPROPRIATE MATERIALS HANDLING EQUIPMENT (SUCH AS A FORKLIFT, DOLLY, OR PALLET JACK) TO REMOVE THE UNIT FROM THE SKID AND MOVE IT TO THE PLACE OF INSTALLATION.



**CAUTION:** ANY STAND, COUNTER OR OTHER DEVICE ON WHICH RANGE WILL BE LOCATED MUST BE DESIGNED TO SUPPORT THE WEIGHT OF THE RANGE (600 LBS.).



# INSTALLATION

**DANGER:** THIS APPLIANCE MUST BE GROUNDED AT THE TERMINAL PROVIDED. FAILURE TO GROUND THE APPLIANCE COULD RESULT IN ELECTROCUTION AND DEATH.



**WARNING:** INSTALLATION OF THE UNIT MUST BE DONE BY PERSONNEL QUALIFIED TO WORK WITH ELECTRICITY. IMPROPER INSTALLATION CAN CAUSE INJURY TO PERSONNEL AND/OR DAMAGE TO EQUIPMENT. UNIT MUST BE INSTALLED IN ACCORDANCE WITH ALL APPLICABLE CODES.



**NOTICE:** The data plate is located behind the access cover to the right of the oven door. The range voltage, wattage, serial number, wire size, and clearance specifications are on the data plate. This information should be carefully read and understood before proceeding with the installation.



**NOTICE:** The installation of any components such as a vent hood, grease extractors, fire extinguisher systems, must conform to their applicable National, State and locally recognized installation standards.



## **4.1 Electrical Connection with an Overhead Switch Box**

Electrical connection must be accomplished with 3 separate connections on remote switch box, and 2 connections on the range. Connection #1 is for incoming power. Connection #2 is for wires connecting switch box to range. Connection #3 is for probe wires only. The probe wires must be connected from the range to the switch box with a shielded cable. Grounded at one end only, running in a separate conduit. Connections for the range are made on the terminal block located behind an access panel to the right of the oven door. Recommend conduit be hooked into the bottom front, below the terminal block, or at the right back of the unit behind the terminal block.

## **4.2 Overhead Switch Box**

The overhead switch box can be mounted anywhere above the range. The electrical service connection can be made anywhere on the body of the switch box.

## **4.3 Range Voltage**

The Lang Model CLR36R-H-S can be operated on 440 Volts.

## INITIAL START UP

### 5.1 PRE-POWER ON

#### Initial Start-up

Before the initial use of the range, the oven must be thoroughly allowed to dry itself out. This is done by setting the thermostat to 350°. Allow the range oven to heat until all vapor and condensation has been eliminated. For best results allow the oven to thoroughly dry out. Allow 8 to 12 hours for this process. Clean top plates thoroughly. Apply salad oil. Turn each plate thermostat to a low position and allow plate to heat for three hours.

**NOTICE:** Somewhere along the rising temperature curve between 200° and 300° a moderate amount of smoke may issue from in and around the Range. The smoke may be repeated somewhere around 350°. Preservation oils and oil accumulated during manufacturing may be coming off as smoke in these temperature ranges. Do not be alarmed.





**CAUTION:** ALWAYS KEEP THE AREA NEAR THE APPLIANCE FREE FROM COMBUSTIBLE MATERIALS.

**CAUTION:** KEEP FLOOR IN FRONT OF EQUIPMENT CLEAN AND DRY. IF SPILLS OCCUR, CLEAN IMMEDIATELY, TO AVOID THE DANGER OF SLIPS OR FALLS.



## **6.1 Range Controls with a Overhead Switch Box**

The hot top controls are, from left to right, left front, left rear, right front, right rear, oven temperature, and oven power. The oven power pilot lamp will illuminate indicating power is applied to the circuit board controlling the oven elements.

## **6.2 Oven Controls**

The oven must be thoroughly preheated before satisfactory baking can be done. The oven will not bake uniformly if not sufficiently preheated. After preheating let the oven cycle 2 or 3 times to ensure complete heating of the entire oven cavity.

The “Roasting and Baking” oven is equipped with a removable rack. For baking pies, bread, or for roasting operations, the rack may be placed directly on the metal deck and the pans placed on the rack. For baking cakes or pastries the rack should be located in the lower position provided by the rack supports at the sides of the range and the pans placed on the rack in this lower position.

**NOTE:** Always place the pans symmetrically on the rack for best results. Keep the oven door closed as much as possible. Excessive door opening will cool the front section of the oven and products placed near the front are likely to bake slower. It is desirable to keep the front edge of the pans at least several inches back from the inside of the door (when closed). Do not permit air from a window or fan to blow into the oven; it will cause uneven heating.

**WARNING:** KEEP WATER AND SOLUTIONS OUT OF CONTROLS. NEVER SPRAY OR HOSE CONTROL CONSOLE, ELECTRICAL CONNECTIONS, ETC.



**CAUTION:** MOST CLEANERS ARE HARMFUL TO THE SKIN, EYES, MUCOUS MEMBRANES AND CLOTHING. PRECAUTIONS SHOULD BE TAKEN TO WEAR RUBBER GLOVES, GOGGLES OR FACE SHIELD AND PROTECTIVE CLOTHING. CAREFULLY READ THE WARNING AND FOLLOW THE DIRECTIONS ON THE LABEL OF THE CLEANER TO BE USED.



## **7.1 After each meal Cleaning**

Empty the grease drawer often or whenever it is 3/4 full. Remove the grease drawer after each meal and wash the inside and outside of the drawer.

Keep the hot top surface clean.

Clean the exterior of the appliance with a hot water and chlorine solution to maintain a gleaming appearance.

Be sure to rinse thoroughly and coat the cooking surface with a thin film of oil to prevent rusting.

## **7.2 Daily**

The range should be thoroughly cleaned at least once a day in addition to the normal after meal cleaning to insure against the accumulation of foreign material. Keep the inside of the oven and metal deck clean, particularly around door opening, door edges and at bottom of door opening so that the door may close tightly.

# TROUBLESHOOTING

## 9.1 Symptoms

What follows is a chart of Symptoms and Possible Causes to aid in diagnosing faults with the oven.

Refer to the Symptoms column to locate the type of failure then to the Possible Cause for the items to be checked.

To test for a possible cause, refer to the TEST section and locate the Possible Cause then refer to test to identify test procedures.

<b>SYMPTOM</b>	<b>POSSIBLE CAUSE</b>
Indicator is not lit.	<ul style="list-style-type: none"><li>• No power to unit</li><li>• Failed switch</li><li>• Failed pilot light</li></ul>
Range will not heat	<ul style="list-style-type: none"><li>• Failed element</li><li>• Switch is not ON</li><li>• Failed contactor</li><li>• Failed thermostat/circuit board</li><li>• Failed transformer</li><li>• Open in wiring between switch box and range</li><li>• Open in terminal block</li></ul>
Product burning	<ul style="list-style-type: none"><li>• Product is cooked too long</li><li>• Failed thermostat/circuit board</li><li>• Failed contactor</li></ul>
Product under done	<ul style="list-style-type: none"><li>• Failed temperature sensor</li><li>• Failed circuit board/thermostat</li><li>• Failed temperature selector</li></ul>

# TROUBLESHOOTING CONT'D

## 9.2 TESTS

### NOTICE:

Service on this, or any other, LANG appliance must be performed by qualified personnel only. Consult your authorized service station directory or call the factory at 1-800-224-LANG (5264), or WWW.LANGWORLD.COM for the service station nearest you.



### WARNING:

**BOTH HIGH AND LOW VOLTAGES ARE PRESENT INSIDE THIS APPLIANCE WHEN THE UNIT IS PLUGGED/WIRED INTO A LIVE RECEPTACLE. BEFORE REPLACING ANY PARTS, DISCONNECT THE UNIT FROM THE ELECTRIC POWER SUPPLY.**



If an item on the list is followed by an asterisk (\*), the work should be done by a factory authorized service representative.

Possible Cause	TEST
Product is cooked too long	<ul style="list-style-type: none"> <li>• No test available, operational condition</li> </ul>
Failed thermostat	<ul style="list-style-type: none"> <li>• Check poles on thermostat for continuity</li> </ul>
Failed element	<ul style="list-style-type: none"> <li>• Remove the wires and check for continuity across the element</li> </ul>
Failed heat contactor	<ul style="list-style-type: none"> <li>• Remove the wires from the contactor coil and check for continuity across the contactor coil connection</li> <li>• Ensure the contactor moveable points move freely up and down</li> <li>• Check for 24 volts at the contactor coil when the computer is running*</li> </ul>
Failed temperature sensor	<ul style="list-style-type: none"> <li>• Check resistance of sensor for accuracy</li> </ul>
Failed pilot light	<ul style="list-style-type: none"> <li>• Check light for resistance</li> </ul>
Failed transformer	<ul style="list-style-type: none"> <li>• Check coils on transformer for correct resistance</li> </ul>

### CAUTION:

**USE OF ANY REPLACEMENT PARTS OTHER THAN THOSE SUPPLIED BY LANG OR THEIR AUTHORIZED DISTRIBUTORS CAN CAUSE BODILY INJURY TO THE OPERATOR AND DAMAGE TO THE EQUIPMENT AND WILL VOID ALL WARRANTIES.**



# PARTS LIST

## CLR36R-H-S

Item #	Description	Part Number	Qty
1	Body	CLR-003	1
2	Vent Back	CLR-529	1
3	Grease Bucket Assembly	CLR-500	1
4	Can Assembly	CLR-001	1
5	Heat Shield	CLR-440	1
6	Door Assembly	CLR-002	1
7	Stainless Steel Jam Nut, 5/8-18	20303-14	2
8	CLR Top Element, 440 Volt, 1500 Watt	11045-06	1
9	Probe Shield	CLR-424	1
10	CLR Bottom Element, 440 Volt	11045-07	1
11	Element Cover	CLR-447	1
12	Element Channel	CLR-444	3
13	Spring Tube Cover	CLR-484-1	1
14	12 1/4" Stainless Steel Hex Head Cap Screw, 3/8-16	20104-53	1
15	Spring Piston	XLHCL-119	1
16	Hood Type Compression Spring	51002-01	1
17	Spring Tube Assembly	CLR-480	1
18	Spring Tube Cap and Bearing Retainer	CLR-482	1
19	Door Spring	CLR-490	1
20	Door Lever and Shaft	CLR-460	1
21	6 1/2" Stainless Steel Hex Head Cap Screw, 1/4-20	20903-03	1
22	Stainless Steel Washer, 1 OD X .638 ID X .125 Thick	20203-09	2
23	Flanged Bronze Bushing, 5/8 ID X 3/4 OD X 5/8 Long	70201-06	2
24	Blank Switch Panel	CLR-530	1
25	Oven Element Cover	CLR-273	1
26	Cover	CLR-272	1
27	Temperature Probe	41100-08	1
28	1 3/8" Heyco Bushings	70801-02	1
29	Overhead Switch Box Assembly	OSB-200	1
30	Component Mount	OSB-209	1
31	10 Pole Terminal Strip, 30 Amp, 600 Volt	30500-04	4

## PARTS LIST CONT'D

### CLR36R-H-S

32	2 Pole Contactor, 30 Amp, 24VAC	30701-04	1
33	Transformer, 480/24 VAC	31400-15	1
34	Black Knob	70701-28	5
35	Pilot Light	31601-07	1
36	Contact Block	30304-31	1
37	2 Position Rotary Switch	30304-30	1
38	Switch Circuit Breaker, 175-450°F	30304-22	4
39	3 Heat Rotary Switch, 240/480VAC, 15 Amp	30304-06	4
40	Hot Top Control Panel	OSB-234	1
41	Chrome Plated Hot Top	50403-22-1	1
42	Element Pan	CLR-513	4
43	Inner Element, 440 Volt, 1850 Watt	11045-09	4
44	Outer Element, 440 Volt, 1650 Watt	11045-08	4
45	Element Plate	CLR-511	4
46	Element Plate Support	CLR-512	12
47	Element Plate Spacer	CLR-514	24
48	Insulation Kit	60106-45	1
49	Shiprail Assembly	CLR-310	1
50	Trimlock	CLR-542	2
51	Oven Harness	CLR-552	1
52	Jumper	CLR-553	4
53	Hot Top Contactor to Term. Strip Wire for the OSB	CLR-561	2
54	Hot Top Element Harness for OSB unit	CLR-555	1
55	Hot Top 3 Heat Switch Harness for OSB	CLR-560	1
56	Hot Top Power to Switch and Contactor Harness	CLR-559	1
57	Hot Top Oven Control Harness for OSB	CLR-557	1
58	Temperature Control Circuit Board	40101-18	1

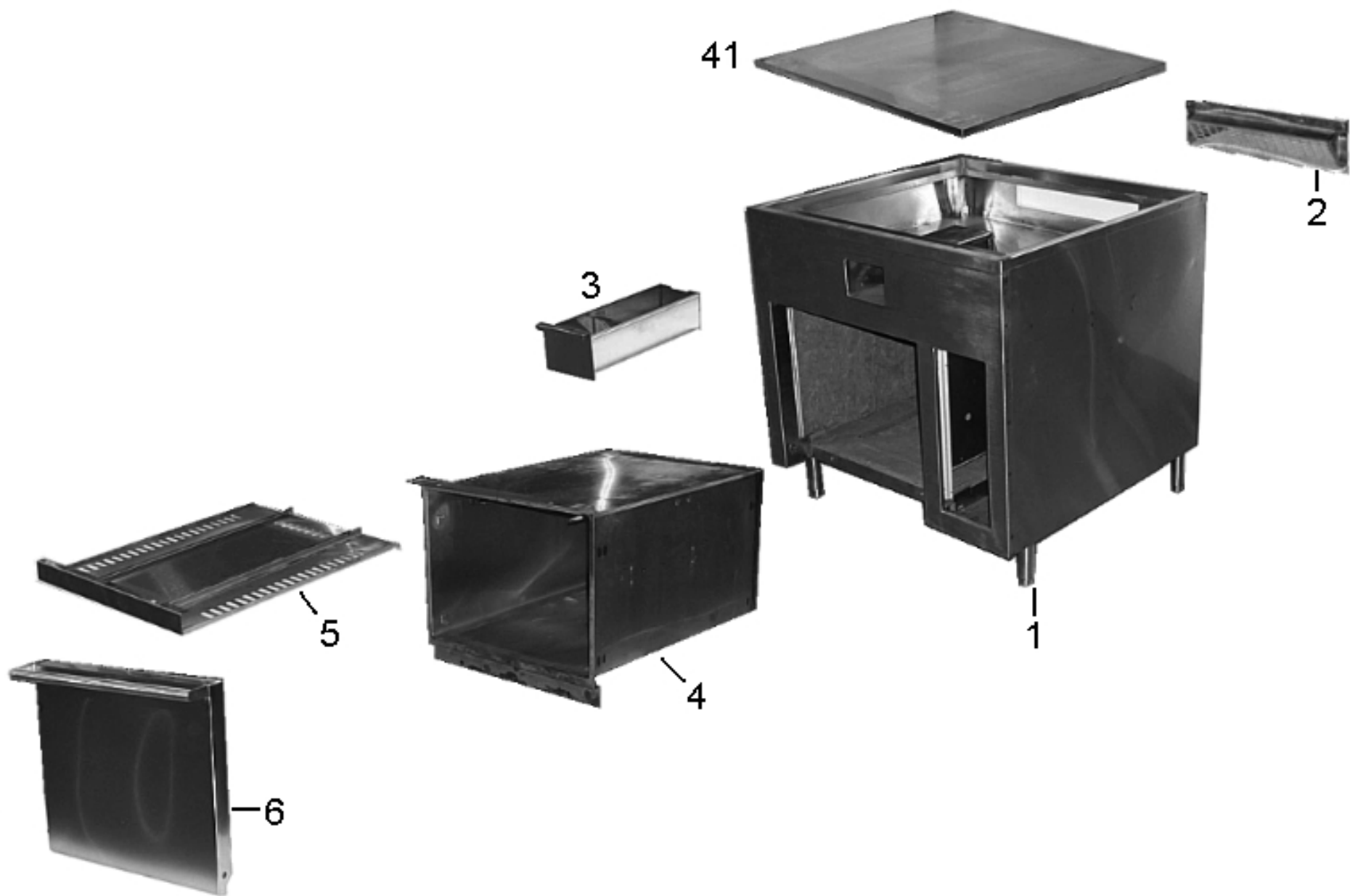

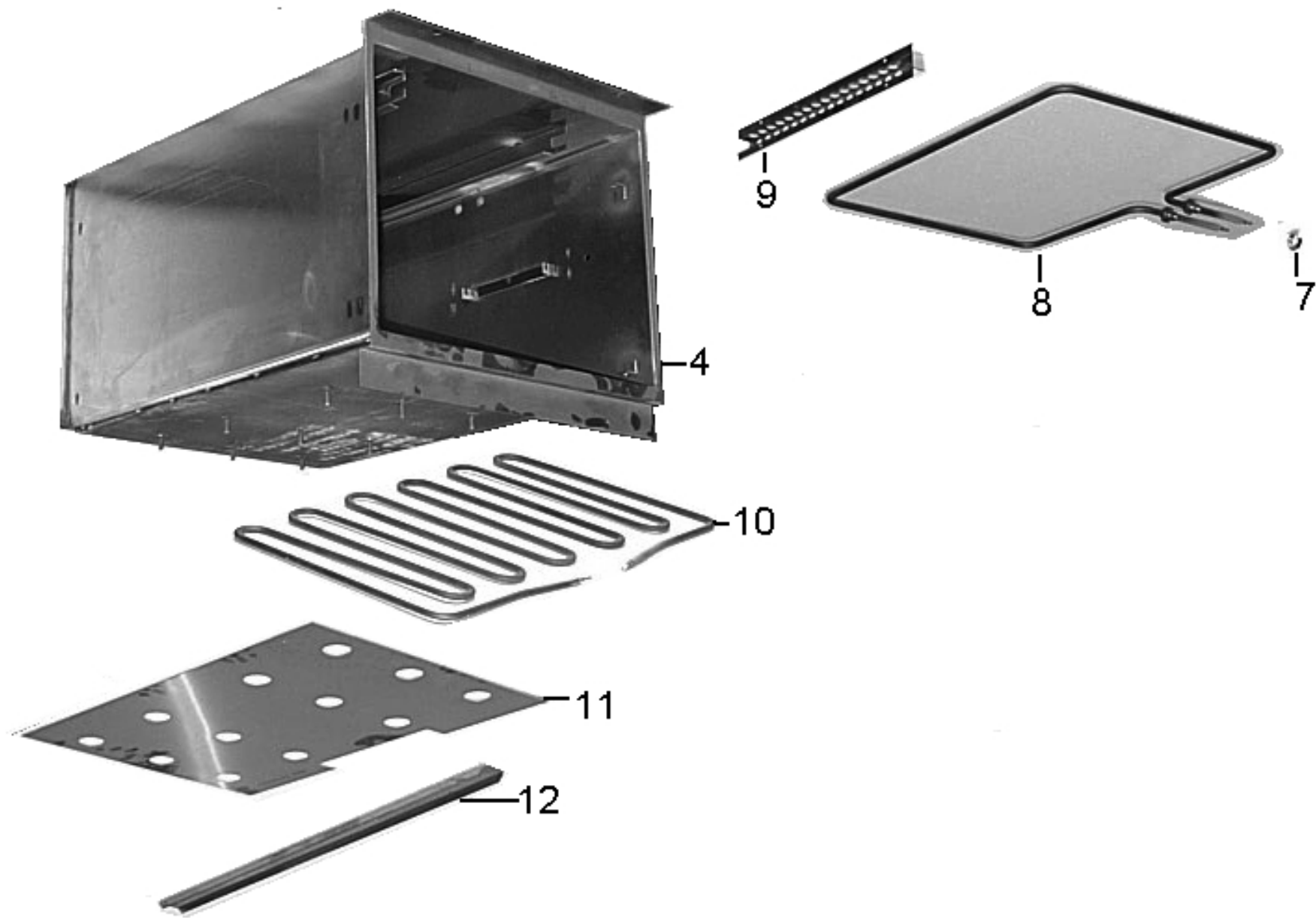



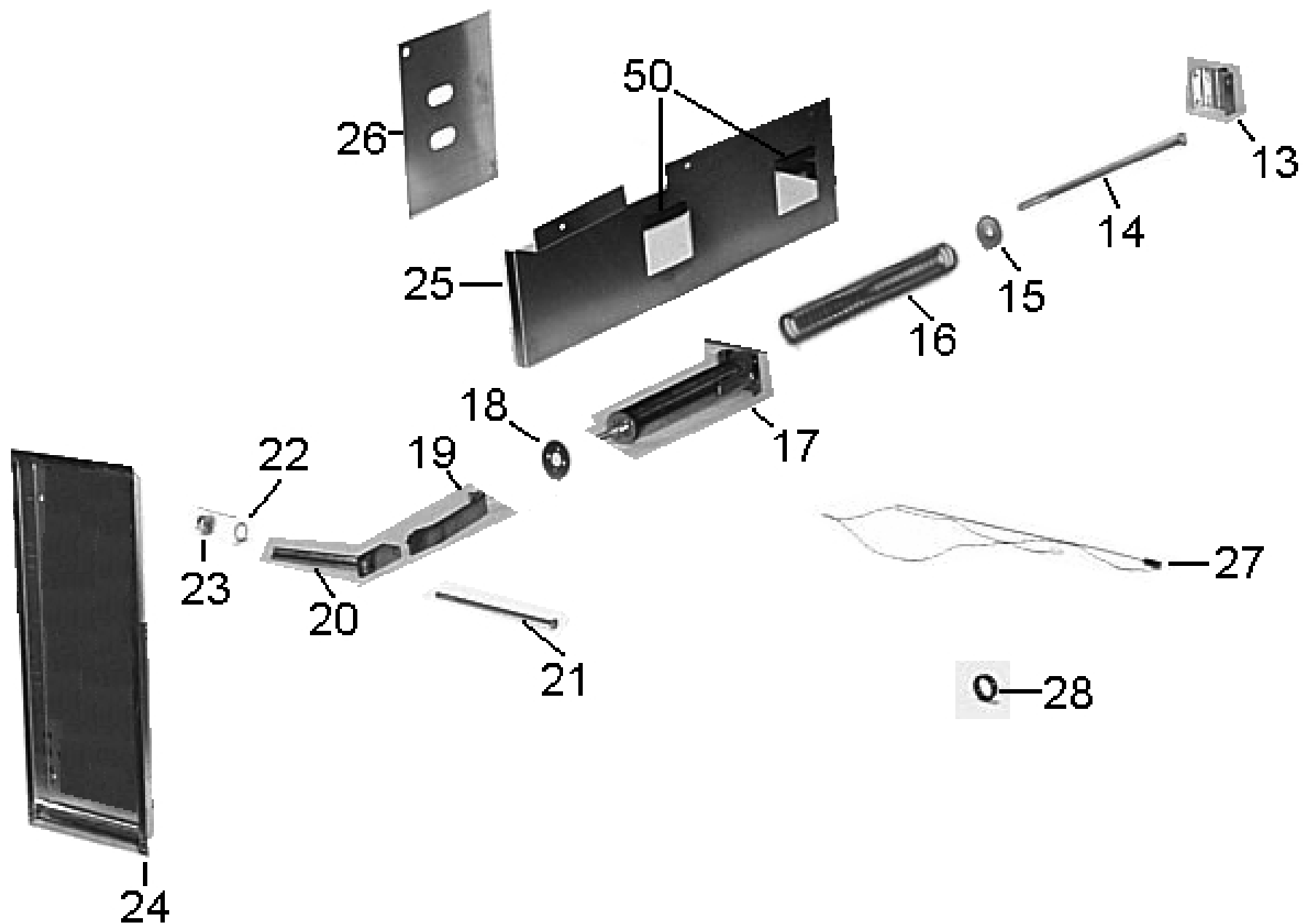

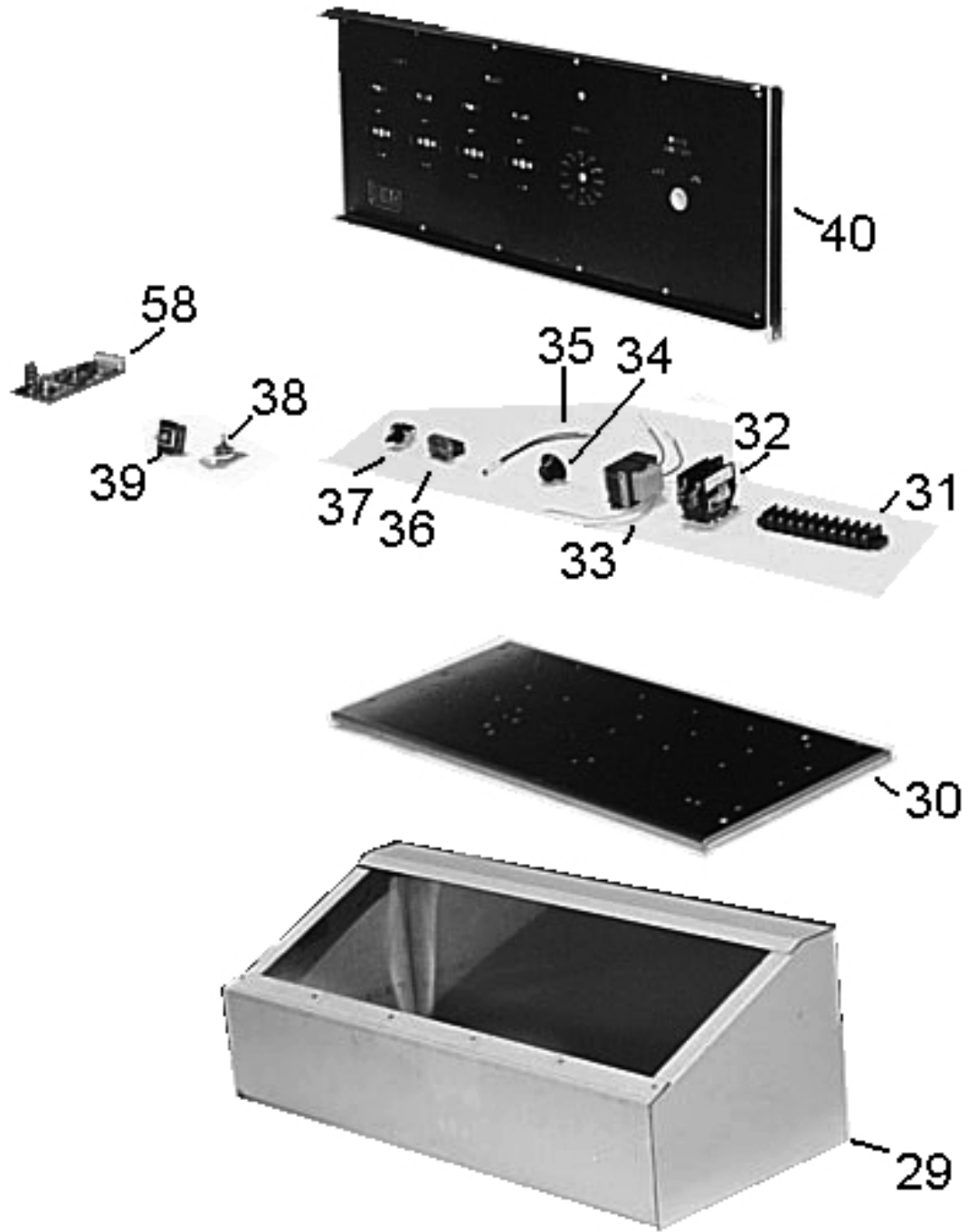

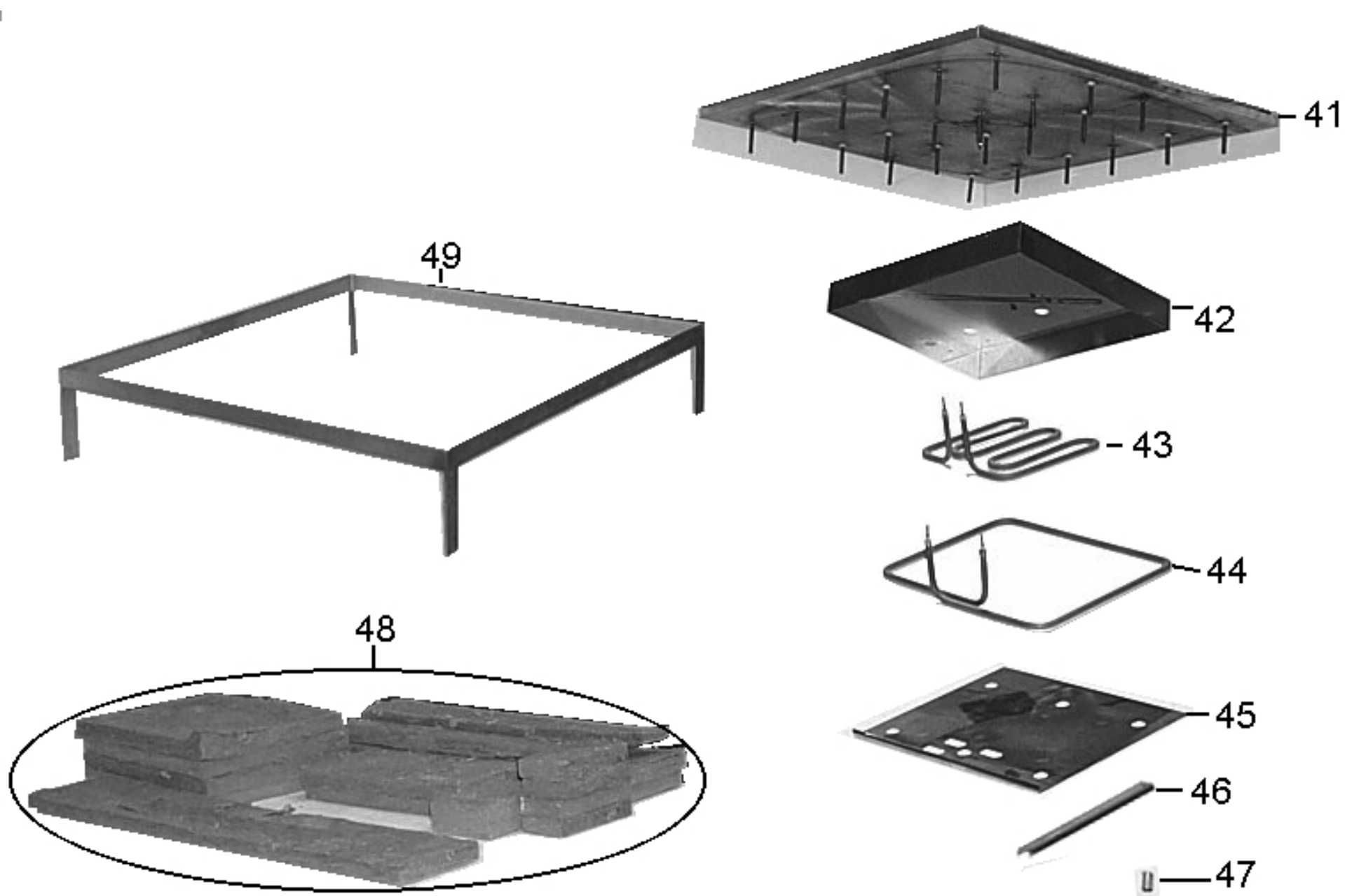

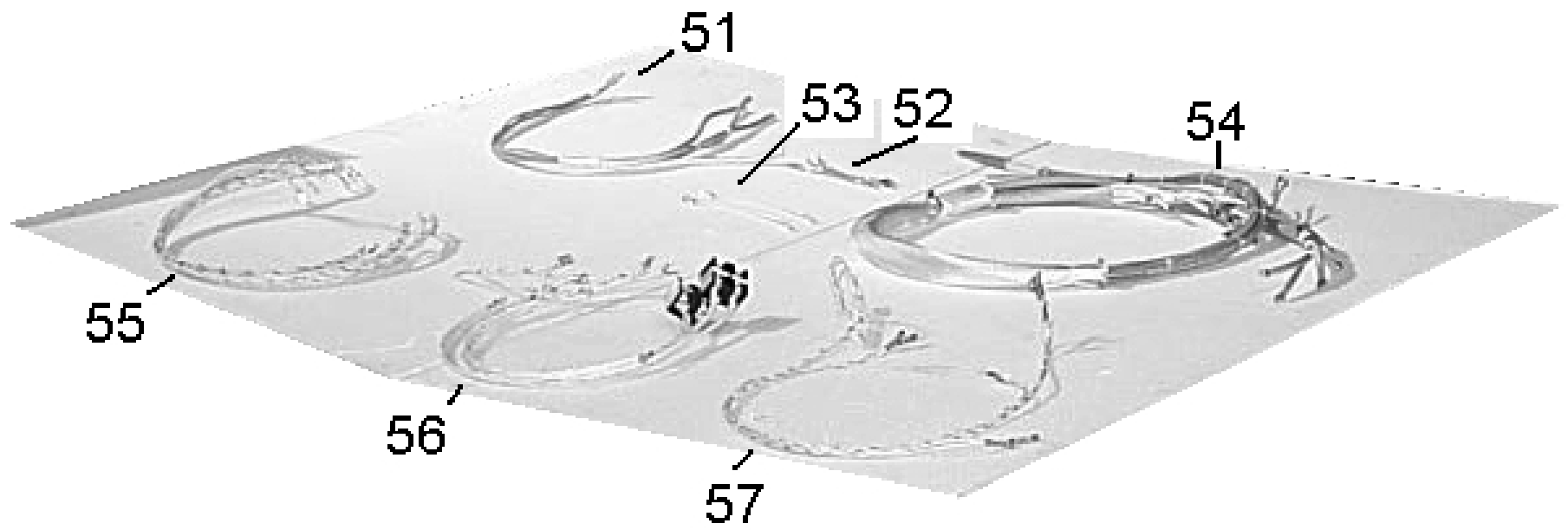

# WIRING DIAGRAM

REVISION BLOCK						
REV	ECN NO.	DESCRIPTION	DR	MFG	ENG	DATE

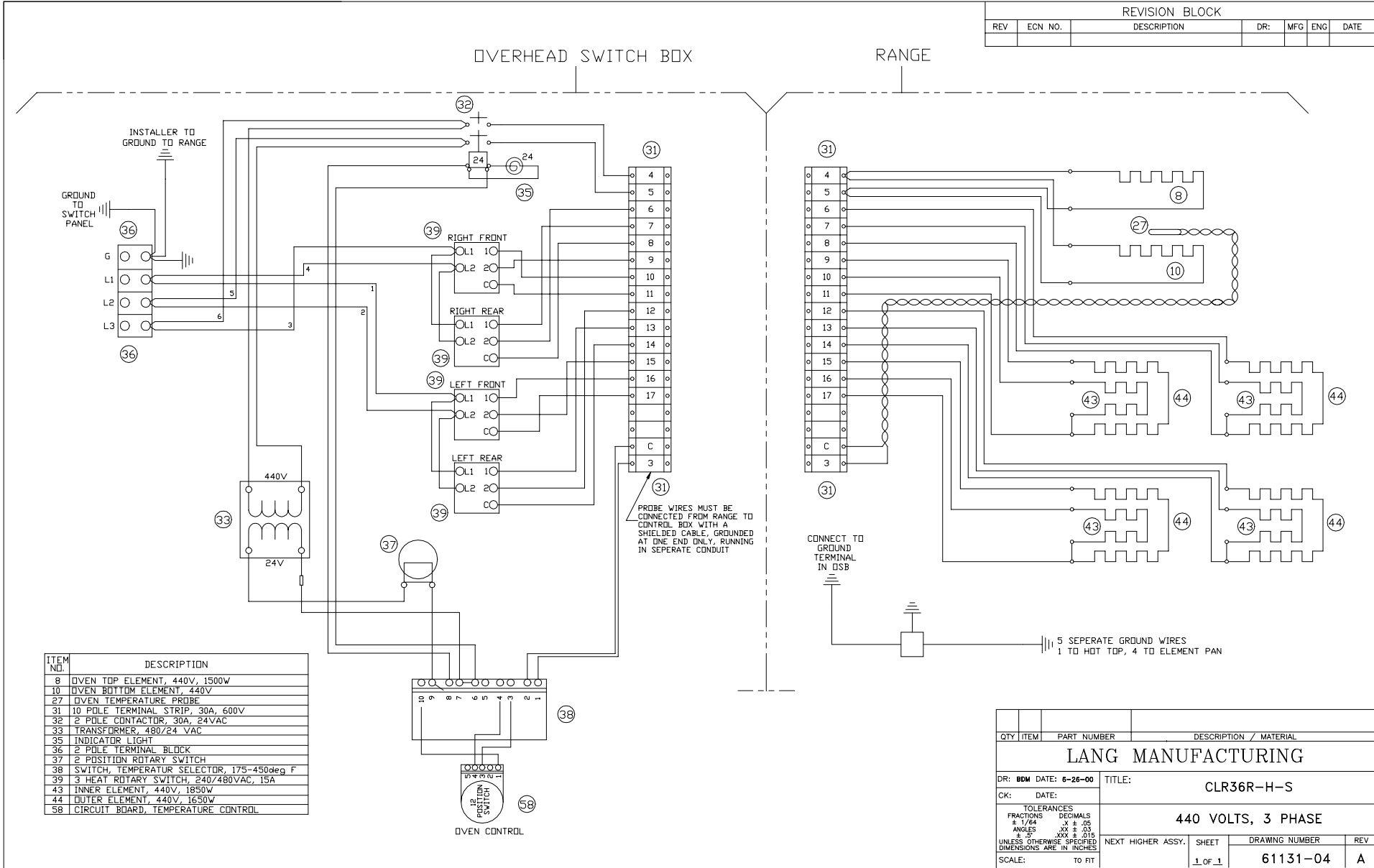

ITEM NO.	DESCRIPTION
8	OVEN TOP ELEMENT, 440V, 1500W
10	OVEN BOTTOM ELEMENT, 440V
27	OVEN TEMPERATURE PROBE
31	10 POLE TERMINAL STRIP, 30A, 600V
32	2 POLE CONTACTOR, 30A, 24VAC
33	TRANSFORMER, 480/24 VAC
35	INDICATOR LIGHT
36	2 POLE TERMINAL BLOCK
37	2 POSITION ROTARY SWITCH
38	SWITCH, TEMPERATUR SELECTOR, 175-450deg F
39	3 HEAT ROTARY SWITCH, 240/480VAC, 15A
43	INNER ELEMENT, 440V, 1850W
44	OUTER ELEMENT, 440V, 1650W
58	CIRCUIT BOARD, TEMPERATURE CONTROL

QTY	ITEM	PART NUMBER	DESCRIPTION / MATERIAL
<b>LANG MANUFACTURING</b>			
DR: BDM DATE: 6-26-00		TITLE: CLR36R-H-S	
CK: DATE:		440 VOLTS, 3 PHASE	
TOLERANCES DECIMALS		NEXT HIGHER ASSY. SHEET	
FRACTIONS ± 1/64		DRAWING NUMBER	
ANGLES XX ± .03		REV	
± .5° XXX ± .015		1 OF 1	
UNLESS OTHERWISE SPECIFIED DIMENSIONS ARE IN INCHES		61131-04	
SCALE: TO FIT		A	

## ***Lang Manufacturing Limited Warranty to Cruise Line Purchasers***

Lang Manufacturing Equipment (“Lang Equipment”) has been skillfully manufactured, carefully inspected and packaged to meet rigid standards of excellence. Lang warrants its Equipment to be free from defects in material and material-related workmanship for (13) thirteen consecutive months from the date of initial shipboard installation or (18) eighteen consecutive months from date of initial factory shipment, whichever ever comes first. The aforementioned warranty statement is subject to the following conditions and limitations.

**I.** This warranty is limited to the provision of replacement components for Product sold by Lang to a joiner company for installation aboard a cruise ship, or a cruise ship company for installation aboard its own ship. The provision of replacement components to affect Product repairs will be on a no-charge basis during the term of the warranty. Replacement components will be sent to the address required within 48 hours of Lang receiving written notification of the description of the defect and the model and serial number of the Product affected by the repair.

Quartz elements are warranted for ninety (90) days from the date of installation.

**II.** Damage during shipment is to be reported to the carrier, is not covered under this warranty, and is the sole responsibility of purchaser/user.

**III.** Replacement components will be shipped F.O.B. factory with freight prepaid. Replacement component damage related to shipment is not covered under this warranty.

**IV.** This warranty does not cover consumable parts such as quartz elements, and does not cover defects caused by improper installation, abuse, careless operation, or improper maintenance of Product.

**V.** All warranties are conditioned upon Lang’s receipt of written notice of any defect prior to the end of the applicable warranty period.

**VI.** THIS WARRANTY IS EXCLUSIVE AND IS IN LIEU OF ALL OTHER WARRANTIES, EXPRESSED OR IMPLIED, INCLUDING ANY IMPLIED WARRANTY OF MERCHANTABILITY OR FITNESS FOR A PARTICULAR PURPOSE, EACH OF WHICH IS HEREBY EXPRESSLY DISCLAIMED. THE REMEDIES DESCRIBED ABOVE ARE EXCLUSIVE AND IN NO EVENT SHALL LANG BE LIABLE FOR SPECIAL, CONSEQUENTIAL OR INCIDENTAL DAMAGES FOR THE BREACH OR DELAY IN PERFORMANCE OF THIS WARRANTY.

**VII.** Lang Equipment is for cruise line use only. If sold as a component of another (OEM) manufacturer’s equipment, or if used as a consumer product, such Equipment is sold AS IS and without any warranty.