



## **Service Manual for the Lang Models:**

**G-2TI, G-3TI, G-4TI, G-5TI, G-6TI**

**G-2TDSI, G-3TDSI, G-4TDSI, G-5TDSI, G-6TDSI**

**G-2EI, G-3EI, G-4EI, G-5EI, G-6EI,**

**G-2EDSI, G-3EDI, G-4EDSI, G-5EDSI, G-6EDSI**

**AGC**

# TABLE OF CONTENTS

<b><u>CHAPTER</u></b>	<b><u>PAGE</u></b>
1. TABLE OF CONTENTS .....	1
2. READ FIRST .....	2
3. EQUIPMENT DESCRIPTION.....	4
4. INSTALLATION .....	5
5. START-UP .....	6
6. GENERAL OPERATION .....	8
7. SEQUENCE OF OPERATION .....	10
8. TROUBLESHOOTING .....	12
9. TECHNICAL DATA.....	16
10. WIRING DIAGRAMS .....	20
11. PARTS LIST.....	25

**CAUTION:** EACH UNIT IS EXTREMELY HEAVY. FOR SAFE HANDLING, INSTALLER SHOULD OBTAIN HELP AS NEEDED, OR EMPLOY APPROPRIATE MATERIALS HANDLING EQUIPMENT (SUCH AS A FORKLIFT, DOLLY, OR PALLET JACK) TO REMOVE THE UNIT FROM THE SKID AND MOVE IT TO THE PLACE OF INSTALLATION.



**CAUTION:** ANY STAND, COUNTER OR OTHER DEVICE ON WHICH GRIDDLE WILL BE LOCATED MUST BE DESIGNED TO SUPPORT THE WEIGHT OF THE GRIDDLE.



**CAUTION:** SHIPPING STRAPS ARE UNDER TENSION AND CAN SNAP BACK WHEN CUT.



**DANGER:** THIS APPLIANCE MUST BE GROUNDED AT THE TERMINAL PROVIDED. FAILURE TO GROUND THE APPLIANCE COULD RESULT IN ELECTROCUTION AND DEATH.



**WARNING:** INSTALLATION OF THE UNIT MUST BE DONE BY PERSONNEL QUALIFIED TO WORK WITH ELECTRICITY AND PLUMBING. IMPROPER INSTALLATION CAN CAUSE INJURY TO PERSONNEL AND/OR DAMAGE TO EQUIPMENT. UNIT MUST BE INSTALLED IN ACCORDANCE WITH ALL APPLICABLE CODES.



**WARNING:** BEFORE LIGHTING, USE A SOAP AND WATER SOLUTION TO TEST ALL JOINTS FOR GAS LEAKS.



**WARNING:** DURING INITIAL USE, OR AFTER SERVICE, IF PILOT DOES NOT IGNITE ON FIRST TRY THE MAIN GAS VALVE MUST BE TURNED OFF FOR AT LEAST FIVE MINUTES.

**NOTICE:** The data plate is located left end of griddle behind control door. The griddle voltage, gas specs, serial number, pipe size, and clearance specifications are on the data plate. This information should be carefully read and understood before proceeding with the installation.



**NOTICE:** The installation of any components such as a vent hood, grease extractors, fire extinguisher systems, must conform to their applicable National, State and locally recognized installation standards.



**NOTICE:** During the first few hours of operation you may notice a small amount of smoke coming off the griddle plate, and a faint odor from the smoke. This is normal for a new griddle and will disappear after the first few hours of use.



**WARNING:** KEEP WATER AND SOLUTIONS OUT OF CONTROLS. NEVER SPRAY OR HOSE CONTROL CONSOLE, ELECTRICAL CONNECTIONS, ETC.



**CAUTION:** ALWAYS KEEP THE AREA NEAR THE APPLIANCE FREE FROM COMBUSTIBLE MATERIALS.

**CAUTION:** KEEP FLOOR IN FRONT OF EQUIPMENT CLEAN AND DRY. IF SPILLS OCCUR, CLEAN IMMEDIATELY, TO AVOID THE DANGER OF SLIPS OR FALLS.



**CAUTION:** MOST CLEANERS ARE HARMFUL TO THE SKIN, EYES, MUCOUS MEMBRANES AND CLOTHING. PRECAUTIONS SHOULD BE TAKEN TO WEAR RUBBER GLOVES, GOGGLES OR FACE SHIELD AND PROTECTIVE CLOTHING. CAREFULLY READ THE WARNING AND FOLLOW THE DIRECTIONS ON THE LABEL OF THE CLEANER TO BE USED.



**NOTICE:** Service on this, or any other, LANG appliance must be performed by qualified personnel only. Consult your authorized service station directory or call the factory at 1-800-224-LANG (5264), or WWW.LANGWORLD.COM for the service station nearest you.



**WARNING:** BOTH HIGH AND LOW VOLTAGES ARE PRESENT INSIDE THIS APPLIANCE WHEN THE UNIT IS PLUGGED/WIRED INTO A LIVE RECEPTACLE. BEFORE REPLACING ANY PARTS, DISCONNECT THE UNIT FROM THE ELECTRIC POWER SUPPLY.



**CAUTION:** USE OF ANY REPLACEMENT PARTS OTHER THAN THOSE SUPPLIED BY LANG OR THEIR AUTHORIZED DISTRIBUTORS CAN CAUSE BODILY INJURY TO THE OPERATOR AND DAMAGE TO THE EQUIPMENT AND WILL VOID ALL WARRANTIES.



## **GAS GRIDDLE**

### **EXTERIOR**

#### ◆ **Griddle**

- The griddle dimensions are 17” (43.18cm) High, 30” (76.20cm) Deep, and width is dependent on the actual model number.
- The Sides, Bottom, and Rear wall are constructed of double wall stainless steel, which allows closer installation to combustible surfaces.
- The griddle surface is made of 1” thick, highly polished steel to reduce hot and cold spots, recovery problems, warping, and ensure even heat to the edges of the griddle.

#### ◆ **AGC Hood**

- The Hood dimension (not including griddle) are 19 1/2” (49.5cm) High with hood down, 38 3/8” (97.5cm) High with hood up, 36 7/8” (93.5cm) Deep, and 23 7/8” (58.6cm) Wide.
- The Hood wrap is constructed of stainless steel and uses infrared heat to broil the product.

### **CONTROLS**

The Gas Griddle is available either with the Lang Accu-Temp controls (G-2TI, G-3TI, G-4TI, G-5TI, G-6TI), the Lang Accu-Temp Direct Spark controls (G-2TDSI, G-3TDSI, G-4TDSI, G-5TDSI, G-6TDSI), the Lang Selectronic controls (G-2EI, G-3EI, G-4EI, G-5EI, G-6EI), and the Lang Selectronic Direct Spark controls (G-2EDSI, G-3EDSI, G-4EDSI, G-5EDSI, G-6EDSI):

#### ◆ **G-TI (Thermostatic ignition)**

- Each twelve-inch section has its own easy to use manual thermostat with a temperature range from 175°F to 450°F in 50° increments.
- Each twelve-inch section has its own individual burner for high efficiency, quick recovery and outstanding performance.

#### ◆ **G-TDSI (Direct Spark, Thermostatic ignition)**

- Same dependable control features as the G-TI with the convenience of the direct spark ignition system.

#### ◆ **G-EI (Electronic ignition)**

- Each twelve-inch section has its own temperature selector switch that snaps into place to lock in any temperature from 175°F to 450°F in 25° increments.
- Each twelve-inch section of the griddle is controlled by an area sensitive RTD probe, which can sense and react to a temperature change of +/- 4°F.
- Each twelve-inch section has its own individual burner for high efficiency, quick recovery and outstanding performance.

#### ◆ **G-EDSI (Direct Spark, Electronic ignition)**

- Same great control features as the G-EI with the convenience of the direct spark ignition system.

# INSTALLATION

## **RECEIVING THE GRIDDLE**

Upon receipt, check for freight damage, both visible and concealed. Visible damage should be noted on the freight bill at the time of delivery and signed by the carrier's agent. Concealed loss or damage means loss or damage, which does not become apparent until the merchandise has been unpacked.

If concealed loss or damage is discovered upon unpacking, make a written request for inspection by the carrier's agent within 15 days of delivery. All packing material should be kept for inspection.

Do not return damaged merchandise to Lang Manufacturing Company. File your claim with the carrier.

Prior to un-crating, move the griddle as near its intended location as practical. The crating will help protect the unit from the physical damage normally associated with moving it through hallways and doorways.

## **ELECTRICAL CONNECTION**

The griddle is supplied with a cord and plug. The receptacle is not provided with the griddle.

Follow the receptacle manufacturer's instructions when connecting the receptacle to the power supply.

## **GAS CONNECTION**

This griddle is manufactured for use with the type of gas indicated on the nameplate. Contact the factory if your type of gas does not match the nameplate data.

All gas connectors must be in accordance with local codes and comply with the National Fuel Gas Code ANSI Z223.1 latest edition.

This appliance should be installed with a separate gas valve in the gas line ahead of the unit. Use a 3/4 inch or larger gas supply line.

**Remove** the 5/16 inch nuts securing the rear of burners. These nuts are for securing the main burners during transportation only. The rear burner shield must be removed to gain access to the nuts.

A pressure regulator for the type of gas specified is supplied with each appliance.

This regulator must be installed in the gas supply line. (Note the direction of the gas flow arrow.) The pressure in the manifold of the appliance should be tested with a manometer and the regulator adjusted for proper pressure with the appliance operating at full fire. A 1/8 inch NPT tap is provided in the manifold for connecting a manometer.

Correct manifold pressures are:

5 inches water column for natural gas

10 inches water column for propane

When replacing the plug in the manifold, a pipe joint compound or sealant should be used that is resistant to the action of liquid petroleum gas.

Initial adjustments are the responsibility of the installer and are not chargeable to Lang Manufacturing Company.

After the griddle is in its final position, adjust the legs to create 1/4 inch slant from back to front. This will allow the grease to run into the grease gutter and provide the proper combustion air for the burners.

**GAS GRIDDLE**

- 1) Verify connections at plug and terminal block
  
- 2) Incoming Volt - Single Phase L1 \_\_\_\_\_
  
- 3) Gas pressure is set for 4.5” WC (Natural Gas), 9” WC (Propane).  
Ensure that the regulator is installed in the correct direction.
  
- 4) Ensure Griddle body is tilted 1/8” lower in front. Confirm there is  
4” clearance below Griddle.
  
- 5) Ensure that burner flame is stable and not lifting off of burner.  
Flame should light around the “U” of each burner with no hesitation.   
Height of flame should be 1 1/4” to 1 1/2” from burner surface.  
**Flames must not lift off of burner ports.**
  
- 6) Ensure that spark electrode does not continue to spark after ignition.  
The tip of the spark electrode and sensor electrodes must have flame  
on them and glowing red.
  
- 7) Verify actual temperature at 350 °F \_\_\_\_\_ °F.  
**Note:** Install thermocouple wire in center of 12” section for that  
control area. Let griddle cycle off and on 3 times before recording  
temperature.

Model # \_\_\_\_\_ Date \_\_\_\_\_ Serial # \_\_\_\_\_

Store # \_\_\_\_\_ Tech Name \_\_\_\_\_  
Contact \_\_\_\_\_ Company \_\_\_\_\_  
Store Phone # \_\_\_\_\_ Service Company Phone # \_\_\_\_\_

Address \_\_\_\_\_  
\_\_\_\_\_  
\_\_\_\_\_

# AGC START-UPS

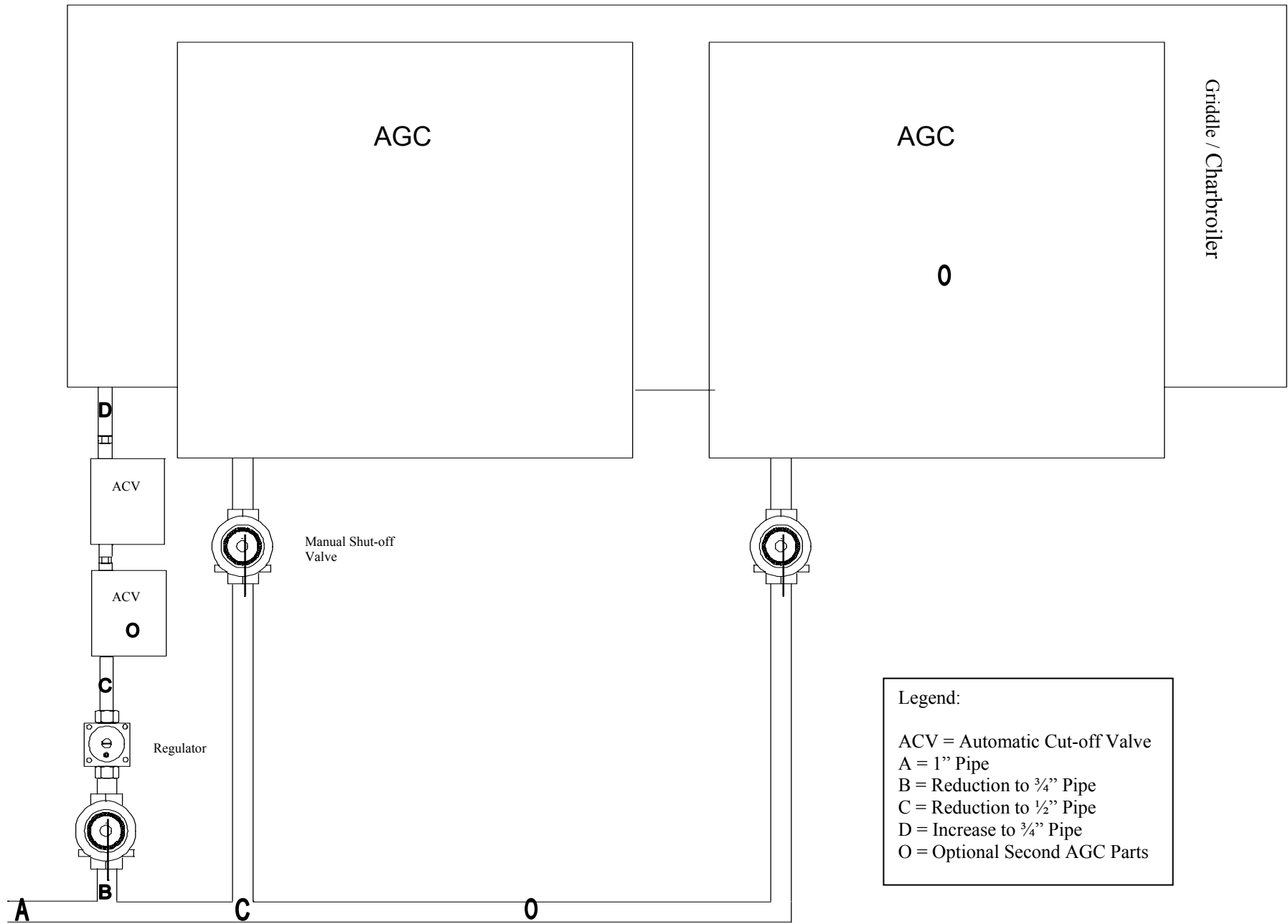

Legend:

- ACV = Automatic Cut-off Valve
- A = 1" Pipe
- B = Reduction to 3/4" Pipe
- C = Reduction to 1/2" Pipe
- D = Increase to 3/4" Pipe
- O = Optional Second AGC Parts



## GENERAL

### GENERAL

The suggested time and temperature chart (below) is provided as a guide for the products listed only.

**CAUTION:** ALWAYS KEEP THE AREA NEAR THE APPLIANCE FREE FROM COMBUSTIBLE MATERIALS.



**CAUTION:** KEEP FLOOR IN FRONT OF EQUIPMENT CLEAN AND DRY. IF SPILLS OCCUR, CLEAN IMMEDIATELY, TO AVOID THE DANGER OF SLIPS OR FALLS.



### SUGGESTED TIMES AND TEMPERATURES WITHOUT AGC HOOD

PRODUCTS	TEMPERATURE (F)	TIME (MIN)
<b>HAMBURGER</b>	350	
2 patties per LB	350	6 to 8
4 patties per LB	350	4 to 6
6 patties per LB	350	3 to 4
<b>STEAKS</b>		
1/2 to 3/4 inch thick, cooked medium	375	5 to 7
3/4 to 1 inch thick, cooked medium	375	8 to 10
Lamb Chops	350	6 to 8
Pork Chops	350	6 to 8
Salmon	350	6 to 8
Halibut	325	6 to 8
Snapper	325	6 to 8
Hashbrown Potatoes	375	3 to 4
Bacon	350	3 to 4
Sausage Links or Patties	350	3 to 4
Ham (Pre-cooked)	375	2
Eggs	275	2 to 4
Note: The times and temperatures in this chart are intended as a general guide and starting point. Your actual times and temperatures may vary from this chart.		

If different temperature settings are to be used, select one side of the griddle and operate at the lowest temperature. Adjoining sections should be set at progressively higher temperatures. Do not try to operate the end sections hot and the center sections cool.

### **OPERATIONS**

An understanding of how the griddle sections are controlled will be a valuable aid in loading your griddle.

Each 12-inch section of your griddle is independently controlled by a temperature controller. The temperature control sensor is mounted in the center of each cooking section under the griddle plate.

If the product is loaded directly over the temperature sensor, that section will turn on and the burner will heat the entire cooking section. If the product is loaded to the side, front or back of the temperature sensor, the thermostat will react to the temperature change much slower.

During slow periods with minimal loads, do not load directly over the thermostat sensors as this will unnecessarily turn the burners on and overheat the remainder of the section not being utilized.

Turn the product and continue cooking until it has reached its desired degree of doneness.

Remove the product from the griddle.

When reloading the griddle, first use the griddle surface on which a previous load was not placed. This will insure you the proper griddle temperature.

## SEQUENCE OF OPERATION

### **G-TI**

#### **Power Switch to “ON” position.**

120 VAC supplied to primary of 120/24 Transformer.

#### **Transformer energizes.**

24 VAC to Pilot valve.

#### **Pilot valve opens.**

120 VAC to Spark Module.

#### **Pilots ignite.**

Flame switch closes.

24 VAC to Power Switch.

#### **Power switch to “ON” position.**

24 VAC to Thermostat.

24 VAC to Main Burner Valve.

#### **Main Burner ignites.**

### **G-TDSI**

#### **Power Switch to “ON” position.**

120 VAC to 120/24 Transformer.

#### **Transformer energizes.**

24 VAC to Thermostat.

24 VAC to Solenoid Valve.

24 VAC between 2 and ground at Spark Module.

#### **Main Burner ignites.**

### **G-EI**

#### **Power Switch to “ON” position.**

120 VAC to 120/24 Transformer.

#### **Transformer energizes.**

24 VAC to Pilot Valve.

#### **Pilot valve opens.**

120 VAC to Spark Module.

#### **Pilots ignite.**

Flame switch closes.

24 VAC at pins # 9 and # 7 of Temperature control board. (The Red L.E.D indicator light on the circuit board is a indication that there is 24 VAC to the board.)

#### **Temperature set on 12-position switch.**

24 VAC at Main burner valve from pin 6 on board. (The Yellow L.E.D indicator light on the circuit board is a indication that the sensor is calling for heat and to close the triac on the board.)

#### **Main burner ignites.**

## SEQUENCE OF OPERATION CONT'D

### **G-EDSI**

#### **Power Switch to “ON” position.**

120 VAC to 120/24 Transformer.

#### **Transformer energizes.**

24 VAC at pins # 9 and # 7 of Temperature control board. (The Red L.E.D indicator light on the circuit board is a indication that there is 24 VAC to the board.)

24 VAC at pin 2 on Spark Module from pin 8 on board. (The Yellow L.E.D indicator light on the circuit board is a indication that the sensor is calling for heat and to close the triac on the board).

24 VAC to Solenoid Valve.

#### **Main Burner ignites.**

### **AGC HOOD**

#### **Power to motor.**

Air switch closes.

120 VAC to transformer.

#### **Transformer energizes.**

24 VAC to Tilt switch.

#### **Hood is lowered.**

24 VAC between “TH” and ground on spark module.

24 VAC at solenoid valve.

#### **Hood ignites.**

## **NO POWER**

<b>PROBABLE CAUSE</b>	<b>CORRECTIVE ACTION</b>
Power switch is not turned on Defective power switch Tripped breaker Defective power cord	<ul style="list-style-type: none"> <li>➤ Turn power switch on.</li> <li>➤ Check power switch for normal operation. Replace as necessary.</li> <li>➤ Reset breaker.</li> <li>➤ Replace power cord.</li> </ul> <p><b>If 120 VAC is measured at primary side of transformer.</b></p> <ul style="list-style-type: none"> <li>➤ Check for 24 volts on the secondary side.</li> <li>➤ If voltage not present replace transformer.</li> </ul>

## **No Power at Valve**

<b>PROBABLE CAUSE</b>	<b>CORRECTIVE ACTION</b>
Faulty flame switch Defective Thermostat (T models) Faulty Temperature board (EDSI and EI models) Defective probe (EDSI and EI models) Faulty Ignition module (EDSI and TDSI models) Faulty electrode assembly (EDSI and TDSI models)	<ul style="list-style-type: none"> <li>➤ Check switch for normal operation. Replace as necessary.</li> <li>➤ Check Thermostat for normal operation. Replace as necessary.</li> <li>➤ Check input and output voltage. 24 volt ac.</li> <li>➤ Verify probe resistance. Replace if open.</li> <li>➤ Check input and output voltages. 24 volts ac.</li> <li>➤ Replace as necessary.</li> </ul>

## NO PILOT

PROBABLE CAUSE	CORRECTIVE ACTION
Gas valve off	➤ Turn it on.
Blocked or pinched gas line	➤ Clear pipe or replace gas line.
Defective valve	➤ Verify Ohms on the coil of the valve at 36Ω.
No voltage at pilot solenoid valve	➤ Check transformer for normal operation.
Plugged vent on the regulator	➤ Clear hole in regulator vent.

## No Burner

PROBABLE CAUSE	CORRECTIVE ACTION
Gas valve off	➤ Turn it on.
Blocked or pinched gas line	➤ Clear pipe or replace gas line.
Defective valve / Sticking	➤ Verify Ohms on the coil of the valve at 36Ω.
No voltage at pilot solenoid valve	➤ Check transformer for normal operation.
Plugged vent on the regulator	➤ Clear hole in regulator vent.
Plugged pilot light	➤ Clean or replace.
Faulty flame switch	➤ Replace.

## TROUBLESHOOTING GEI CONT'D

### Heat Erratic

PROBABLE CAUSE	CORRECTIVE ACTION
Flame too low. Plugged orifice or vent on regulator	➤ Clean or replace orifice. Adjust gas pressure. Clean vent on regulator.
Flame lifting off of burner ports	➤ Adjust air shutters. Adjust gas pressure.
Flame not present on one side of burner ports	➤ Drill 2 – 3 # 53 holes at the corners of the burners to help flame around U of burner or replace burner.
Loose or greasy connections in the control wiring or at control boards.	➤ Fix loose connections and spray connections with contact cleaner.
Faulty probe or incorrect probe placement	➤ Verify probe resistance. Check probe placement.
	<p><b>NOTE: Follow Lang griddle calibration procedure to verify the temperature.</b></p>

## TROUBLESHOOTING AGC

### Hood will not light

PROBABLE CAUSE	CORRECTIVE ACTION
Defective Module	<ul style="list-style-type: none"> <li>➤ Confirm that igniter is sparking.</li> <li>➤ Check for 24 VAC between “TH” and ground.</li> </ul> <p><b>If 24 VAC is present:</b></p> <ul style="list-style-type: none"> <li>➤ Replace module.</li> </ul> <p><b>If 24 VAC is not present:</b></p> <ul style="list-style-type: none"> <li>➤ Check Tilt switch for normal operation.</li> </ul>
Defective Solenoid Valve	<ul style="list-style-type: none"> <li>➤ Check for 24 VAC at Coil.</li> </ul> <p><b>If 24 VAC is present:</b></p> <ul style="list-style-type: none"> <li>➤ Check Coil for 36 Ω.</li> <li>➤ Replace as necessary.</li> </ul> <p><b>If 24 VAC is not present:</b></p> <ul style="list-style-type: none"> <li>➤ Check Module for normal operation.</li> </ul>
Defective Transformer	<ul style="list-style-type: none"> <li>➤ Confirm incoming voltage.</li> <li>➤ Confirm outgoing voltage.</li> </ul>
Defective Air Switch	<ul style="list-style-type: none"> <li>➤ Check switch for continuity.</li> <li>➤ Confirm motor is running.</li> </ul>
Defective Motor	<ul style="list-style-type: none"> <li>➤ Confirm that motor is getting voltage.</li> </ul>
Improper Air Mixture	<ul style="list-style-type: none"> <li>➤ Adjust Air mixture.</li> </ul>
Gas Pressure to low	<ul style="list-style-type: none"> <li>➤ Adjust Gas pressure. (NG=3.5”W/C, LP=8”W/C)</li> </ul>
Plugged Pilot enrichment Orifice	<ul style="list-style-type: none"> <li>➤ Clear or Replace orifice.</li> </ul>
Spark ignition to far or to close to Burner tiles	<ul style="list-style-type: none"> <li>➤ Adjust to 1/4” away from tile.</li> </ul>



## TECHNICAL DATA

### TRANSFORMER RESISTANCE

TRANSFORMER	Part #	Input	Primary	Secondary	Output
➤ 120/24 Volt	31400-07	120 Volt	18.9 $\Omega$	1 $\Omega$	24 Volt

### SOLENOID VALVE RESISTANCE

VALVE	Part #	Coil
➤ 24 Volt	80502-03	36 $\Omega$

### TEMPERATURE SELECTOR SWITCH RESISTANCE (30304-22)

**NOTES:** Make checks from the back of the switch with wires still connected on pins 1 and 3. (Pin one being on the left hand side)

Switch Position	Resistance
1	Open
2	154
3	286
4	400
5	500
6	578
7	632
8	668
9	674
10	656
11	611
12	539

**Lang Griddle Calibration Check Procedures**

To verify calibration:

1. Set the Griddle temperature to 350°F on all sections. (It should take approximately 22 minutes to reach temperature.)
2. Let the griddle reach 350°F and cycle at least three times.
3. Measure 6" from the left, and 11 1/2" from the front of the plate for the first check point. (This will check the center of the probe for the first cooking section.)
4. Each checkpoint is located every 12" to the right from the last point, and always 11 1/2" from the front. (See Illustration 1.)

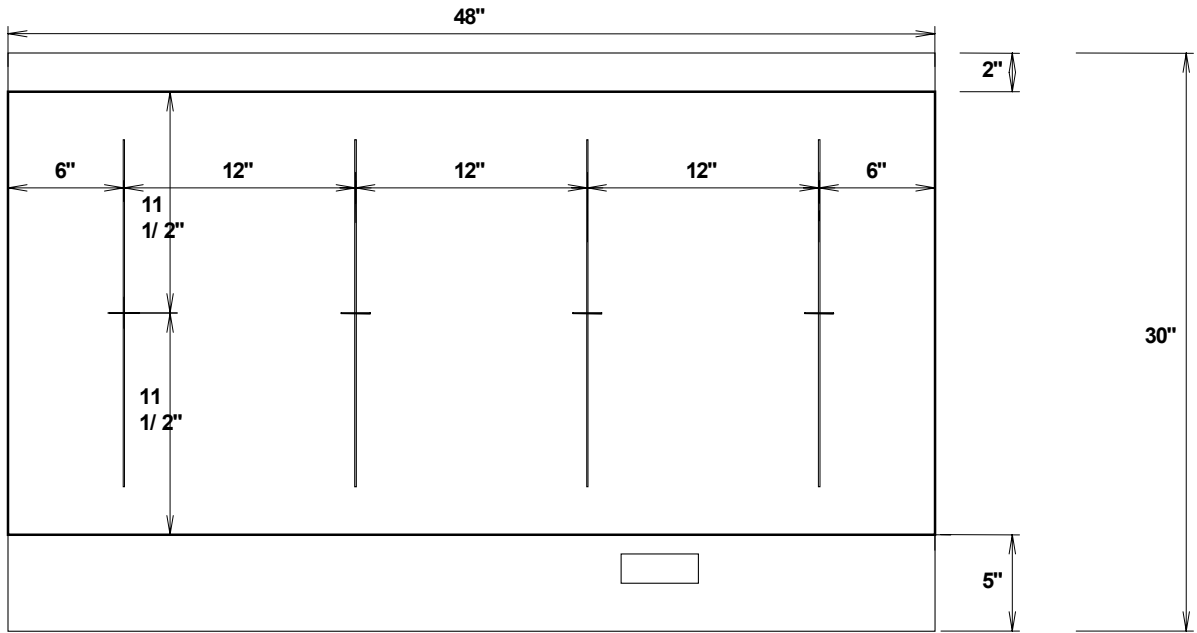

**Illustration 1**

5. Record the on temperature and the off temperature as each sections cycles.
6. Repeat the recording three times. (Use Table 1 to record your temperatures.)

Temperature	Section 1	Section 2	Section 3	Section 4
On				
Off				
On				
Off				
On				
Off				
Average				

## PROBE RESISTANCE

TEMP	RESISTANCE	VOLT DROP	TEMP	RESISTANCE	VOLT DROP
70°	556 Ω	1.11	290°	881 Ω	1.76
80°	569 Ω	1.14	300°	897 Ω	1.79
90°	583 Ω	1.17	310°	914 Ω	1.83
100°	596 Ω	1.19	320°	931 Ω	1.86
110°	610 Ω	1.22	330°	948 Ω	1.90
120°	623 Ω	1.25	340°	965 Ω	1.93
130°	637 Ω	1.27	350°	983 Ω	1.97
140°	651 Ω	1.3	360°	1000 Ω	2.00
150°	665 Ω	1.33	370°	1018 Ω	2.04
160°	678 Ω	1.36	380°	1036 Ω	2.07
170°	694 Ω	1.39	390°	1054 Ω	2.11
180°	709 Ω	1.42	400°	1072 Ω	2.14
190°	724 Ω	1.45	410°	1090 Ω	2.18
200°	739 Ω	1.48	420°	1109 Ω	2.22
210°	754 Ω	1.51	430°	1127 Ω	2.25
220°	769 Ω	1.54	440°	1146 Ω	2.29
230°	785 Ω	1.57	450°	1165 Ω	2.33
240°	800 Ω	1.60	460°	1184 Ω	2.37
250°	816 Ω	1.63	470°	1204 Ω	2.41
260°	832 Ω	1.66	480°	1223 Ω	2.45
270°	848 Ω	1.70	490°	1243 Ω	2.49
280°	864 Ω	1.73	500°	1263 Ω	2.53

### NOTE

Probe is factory checked at 350 °F. Must be completely disconnected from circuit board when measuring probe resistance.

# TECHNICAL DATA CONT'D

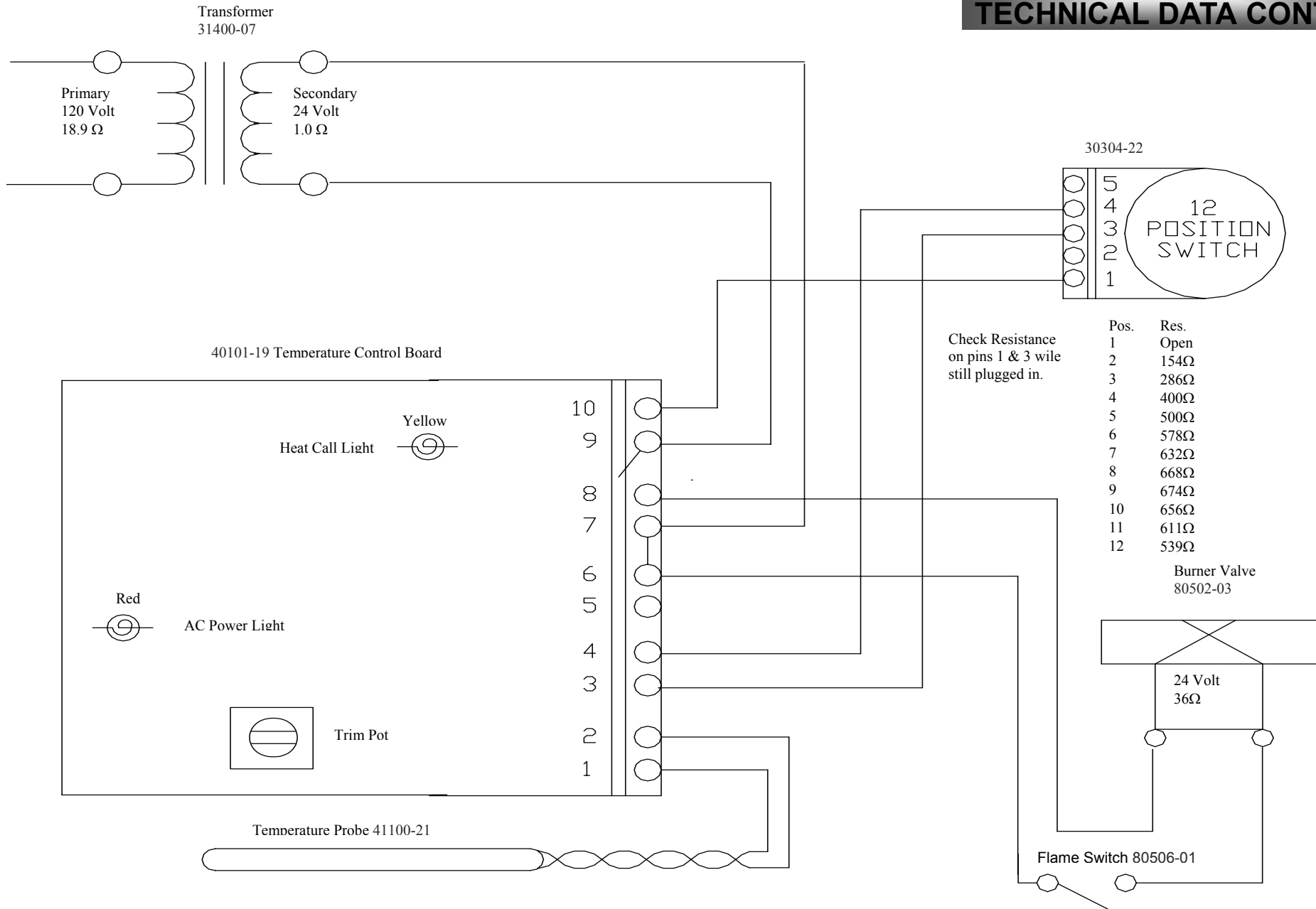

# WIRING DIAGRAM G-TI

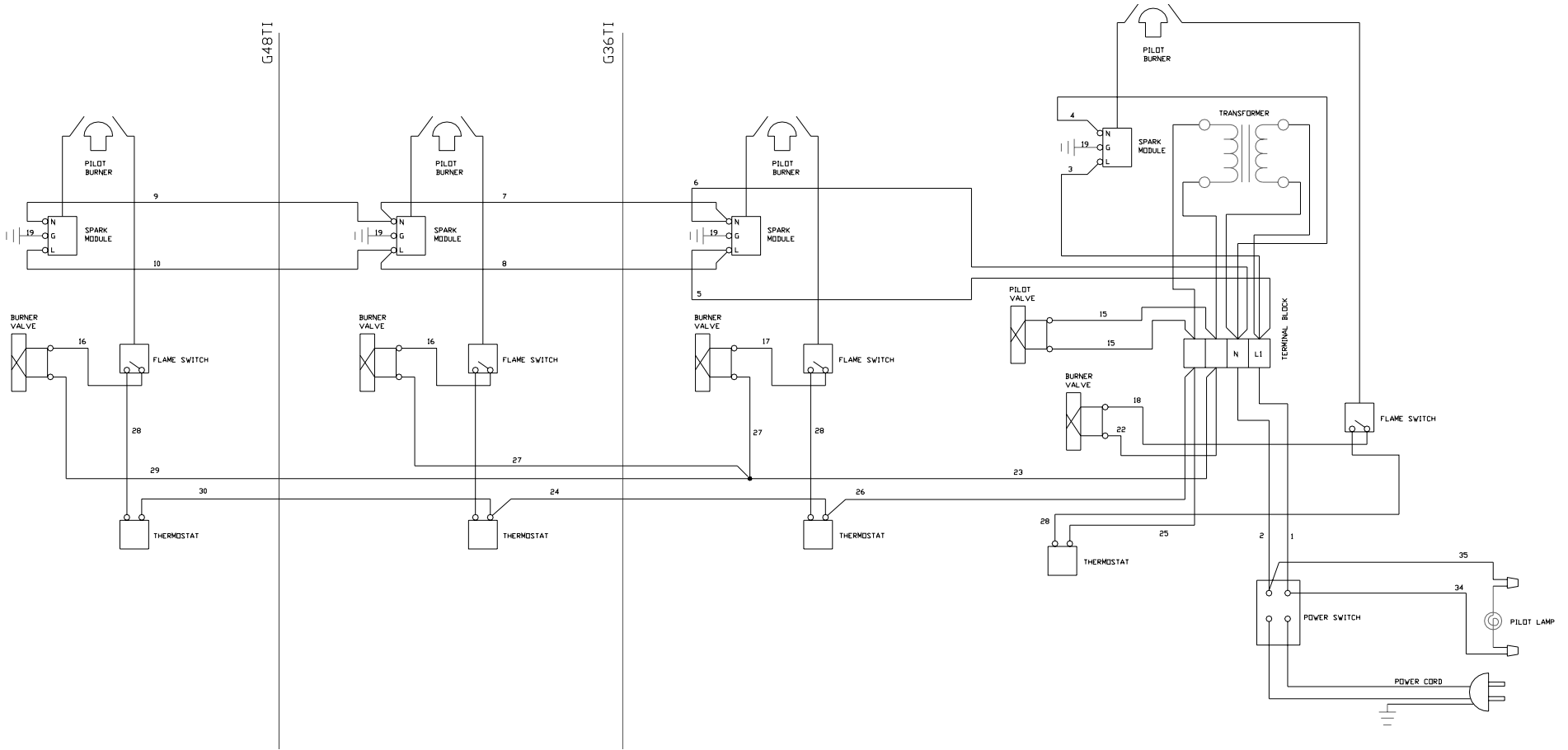

# WIRING DIAGRAM G-TDSI

FP = FLAME PROBE  
 SE = SPARK ELECTRODE  
 SC = SPARK CONTROL  
 SV = SOLENOID VALVE  
 B = BURNER  
 T = THERMOSTAT

REVISION BLOCK						
REV	ECN NO.	DESCRIPTION	DR:	MFG	ENG	DATE

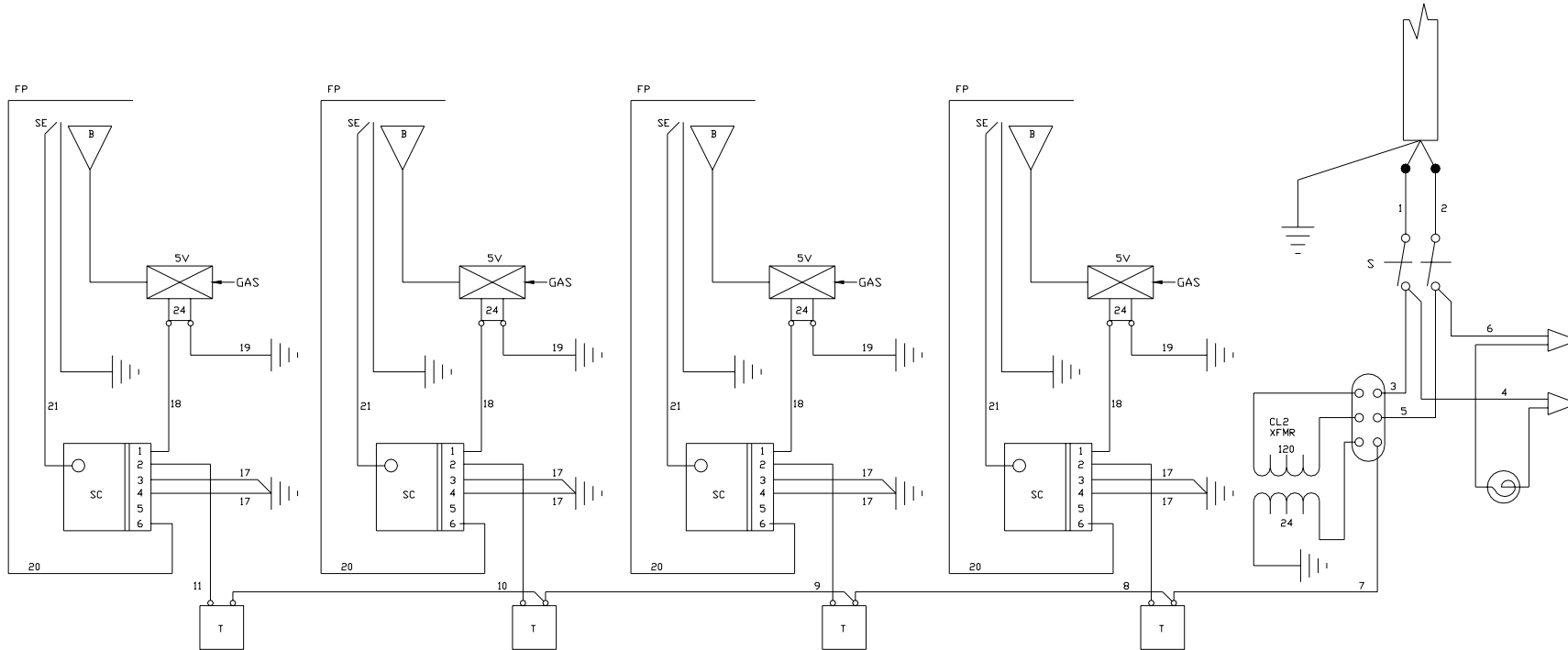

G24TDSI  
 G36TDSI  
 G48TDSI  
 G60TDSI  
 G72TDSI

QTY	ITEM	PART NUMBER	DESCRIPTION / MATERIAL
<b>LANG MANUFACTURING</b>			
DR: SRC DATE: 12-2-97		TITLE: GAS GRIDDLE DSI ACCUTEMP	
CK: DATE:		G48TDSI WIRING DIAGRAM	
TOLERANCES: FRACTIONS    DECIMALS ± 1/64        .X ± .05 ANGLES       .XX ± .03 ± .5°        .XXX ± .015 UNLESS OTHERWISE SPECIFIED DIMENSIONS ARE IN INCHES		NEXT HIGHER ASSY.	SHEET
SCALE: TO FIT		1 OF 1	DRAWING NUMBER
			61122-17
			REV

# WIRING DIAGRAM G-EI

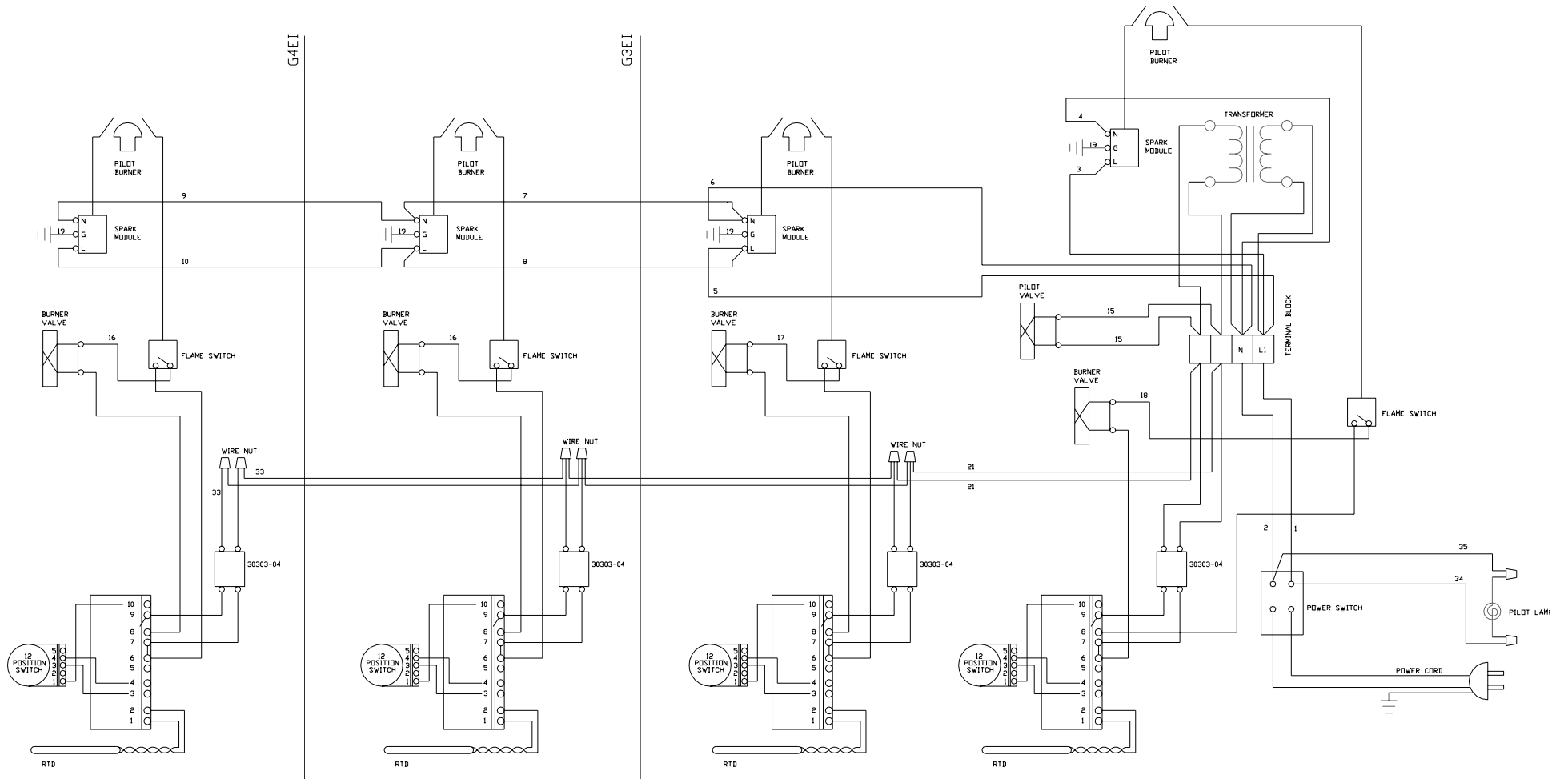

# WIRING DIAGRAM G-EDSI

FP = FLAME PROBE  
 SE = SPARK ELECTRODE  
 SC = SPARK CONTROL  
 SV = SOLENOID VALVE  
 SS = 12 POSITION SELECTOR SWITCH  
 TC = TEMP. CONTROL BOARD  
 B = BURNER  
 S = SWITCH

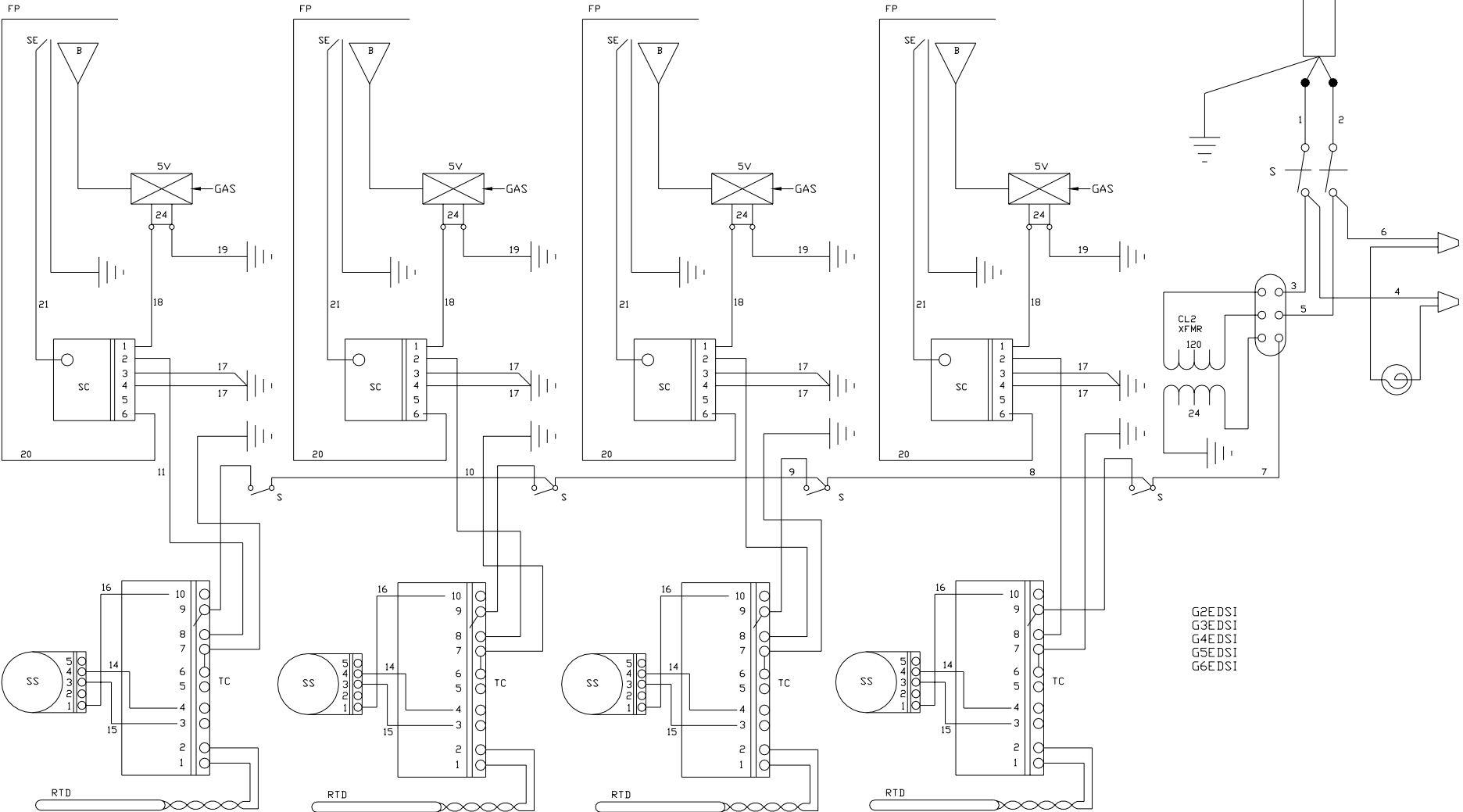



# AGC HOOD

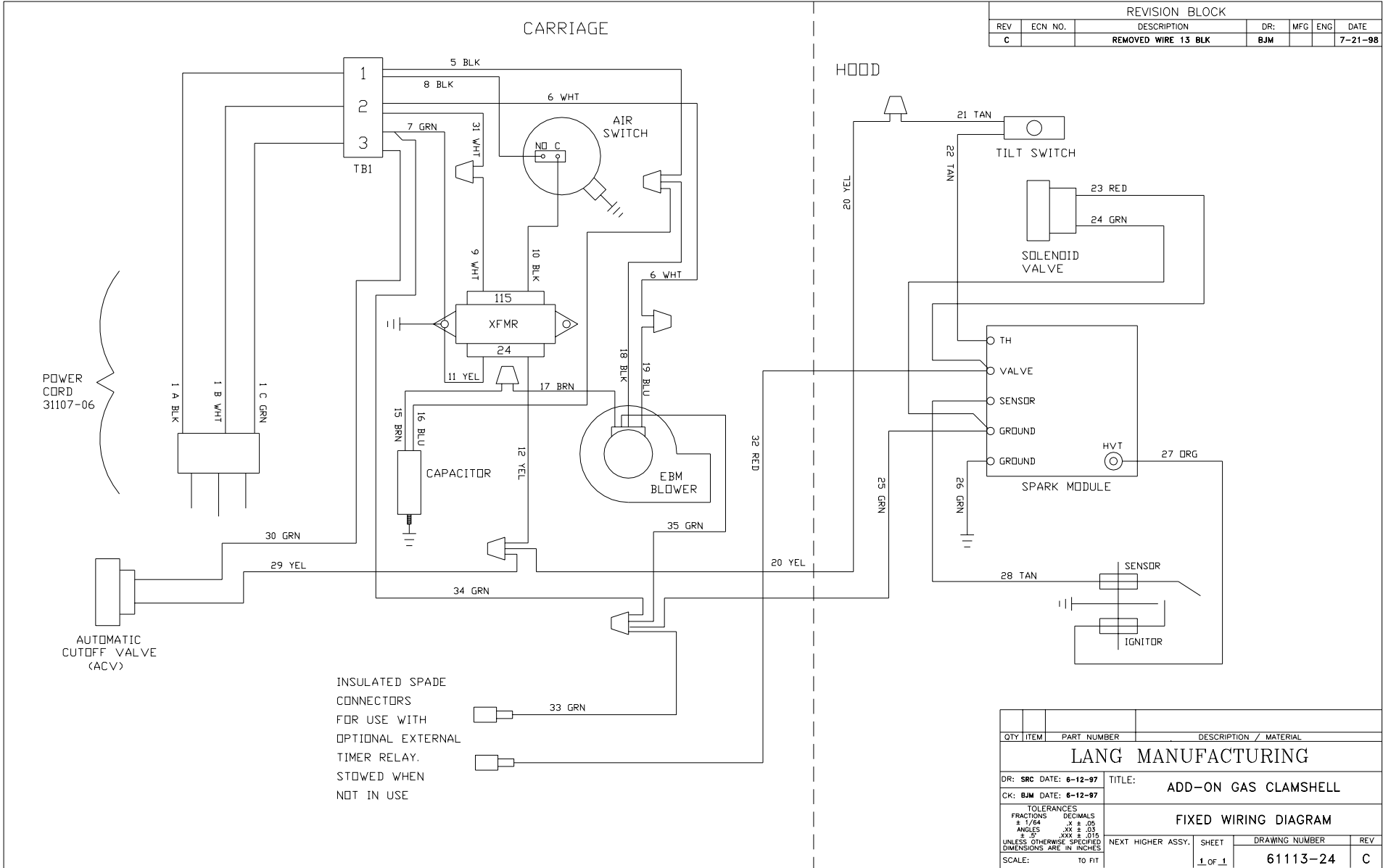

QTY	ITEM	PART NUMBER	DESCRIPTION / MATERIAL
<b>LANG MANUFACTURING</b>			
DR: SRC DATE: 6-12-97		TITLE: ADD-ON GAS CLAMSHELL	
CK: BJM DATE: 6-12-97			
<b>FIXED WIRING DIAGRAM</b>			
<small>TOLERANCES            FRACTIONS    DECIMALS            ± 1/64        X ± .05            ANGLES       XX ± .03                          XXX ± .015            ± .5"            UNLESS OTHERWISE SPECIFIED            DIMENSIONS ARE IN INCHES</small>		NEXT HIGHER ASSY.	SHEET
SCALE: TO FIT		1 OF 1	DRAWING NUMBER
			61113-24
			REV
			C

**G-24TI, G-36TI, G-48TI, G-60TI, G-72TI****GAS ACCU-TEMP GRIDDLE**

<b>DESCRIPTION</b>	<b>PART NO.</b>
Switch, Toggle On-Off	30303-06
Thermostat 450°F Griddle	30402-27
Terminal Strip 4 Pole	30501-03
Power Cord with Molded Plug	31107-02
Transformer 120/24 VAC	31400-07
Pilot Light 208/240V 6" Lead Black Body	31601-01
Grooved Griddle Cleaning Tool	50100-05
Grooved Griddle Cleaning Tool – Replacement Fingers	50100-051
Grooved Griddle Cleaning Tool – Replacement Blades	50100-052
Knob Temperature Control	70701-16
Legs 4" Stainless Steel	72500-02
Burner "J" Tube Steel	80002-09-1
Burner "J" Tube Steel Left Hand Section	80002-07-1
Pilot Burner Assembly Sections 2, 3, 4, 5 & 6	80201-24
Pilot Burner Assembly Section 1 (and 4 on 6ft Units Only)	80201-25
Module Spark Ignitor	80300-03
Orifice Main Burner #42 DRL NG	80400-11
Orifice Main Burner #53 DRL LP	80400-12
Orifice Pilot Burner .018 DRL NG	80401-01
Orifice Pilot Burner .010 DRL LP	80401-02
Regulator Gas Set 5" NG Griddle	80501-04
Regulator Gas Set 10" LP Griddle	80501-05
Regulator Gas Spring Conversion Kit NG to LP	80501-07
Valve Solenoid Gas 24 VAC	80502-03
Flame Switch 24" Long Capillary	80506-01

**G-24TDSI, G-36TDSI, G-48TDSI, G-60TDSI, G-72TDSI****GAS ACCU-TEMP GRIDDLE**

<b>DESCRIPTION</b>	<b>PART NO.</b>
Switch, Toggle On-Off	30303-06
Thermostat 450°F Griddle	30402-27
Terminal Strip 3 Pole	30501-02
Power Cord with Molded Plug	31107-02
Transformer 120/24 VAC	31400-07
Transformer 240/24 VAC	31400-10
Pilot Light 208/240V 6" Lead Black Body	31601-01
Grooved Griddle Cleaning Tool	50100-05
Grooved Griddle Cleaning Tool – Replacement Fingers	50100-051
Grooved Griddle Cleaning Tool – Replacement Blades	50100-052
Knob Temperature Control	70701-16
Silicone Nipple 7mm	70801-10
Legs 4" Stainless Steel	72500-02
Burner "J" Tube Steel	80002-09-1
Burner "J" Tube Steel Left Hand Section	80002-07-1
Module Spark Ignitor	60101-910
DSI Electrode Assembly	80302-05
Orifice Main Burner #42 DRL NG	80400-11
Orifice Main Burner #53 DRL LP	80400-12
Orifice 90° Fitting NG	80401-01
Orifice 90° Fitting LP	80401-02
Regulator Gas Set 5" NG Griddle	80501-04
Regulator Gas Set 10" LP Griddle	80501-05
Regulator Gas Spring Conversion Kit NG to LP	80501-07
Valve Solenoid Gas 24 VAC	80502-03
Wire Harness #1 (Sense/Spark)	EZG-701

**G-2EI, G-3EI, G-4EI, G-5EI, G-6EI****GAS SELECTRONIC GRIDDLE**

<b>DESCRIPTION</b>	<b>PART NO.</b>
Switch Toggle On-Off for Each 1ft Section (After F-89817)	30303-04
Switch Toggle On-Off	30303-06
Switch Temperature Control 12 Position 42" Harness (Before D-45887)	30304-11
Switch Temperature Control 12 Position 175-450°F (After E-51388)	30304-22
Terminal Strip 3 Pole (After E-51388)	30501-02
Terminal Strip 4 Pole (After E-51388)	30501-03
Power Cord with Molded Plug	31107-02
Transformer 120/24 VAC	31400-07
Pilot Light 208/240V 6" Lead Black Body (After E-51388)	31601-01
Circuit Board Temperature Control (Before D-45887)	40101-07
Circuit Board Temperature Control (After E-51388)	40101-19
Probe Temperature Sensor (Before D-45887)	41100-06
Probe Temperature Sensor (From E-51388 to E-89816)	41100-13
Probe Temperature Sensor (After F-89817)	41100-21
Grooved Griddle Cleaning Tool	50100-05
Grooved Griddle Cleaning Tool – Replacement Fingers	50100-051
Grooved Griddle Cleaning Tool – Replacement Blades	50100-052
Panel Label	60301-29
Catch Spring with Striker Plate (Before D-45887)	70602-02
Catch Magnetic Door (After E-51388)	70602-06
Knob Temperature Control	70701-28
Spacer Support 1/2" Nylon	70801-07
Burner "J" Tube Steel	80002-09-1
Burner "J" Tube Steel Left Hand Section	80002-07-1
Pilot Burner Assembly Sections 2, 3, 4, 5, & 6 (Before D-45887)	80201-10
Pilot Burner Assembly Section 1 (and 4 on 6ft Units Only) (Before D-45887)	80201-19
Pilot Burner Assembly Sections 2, 3, 4, 5, & 6 (After E-51388)	80201-24
Pilot Burner Assembly Section 1 (and 4 on 6ft Units Only) (After E-51388)	80201-25
Spark Module Ignitor	80300-03
Orifice Main Burner #42 DRL NG	80400-11
Orifice Main Burner #53 DRL LP	80400-12
Orifice Pilot Burner .018 DRL NG	80401-01
Orifice Pilot Burner .010 DRL LP	80401-02
Regulator Gas Set 5" NG Griddle	80501-04
Regulator Gas Set 10" LP Griddle	80501-05
Regulator Gas Spring Conversion Kit NG to LP	80501-07
Valve Solenoid Gas 120 VAC (Before D-45887)	80502-01
Valve Solenoid Gas 24 VAC (From E-51388 to E-89816)	80502-03
Valve Combination Gas (Before D-45887)	80505-04
Flame Switch 24" Long Capillary	80506-01

**G-2EDSI, G-3EDSI, G-4EDSI, G-5EDSI, G-6EDSI****GAS SELECTRONIC GRIDDLE**

<b>DESCRIPTION</b>	<b>PART NO.</b>
Switch Toggle On-Off	30303-06
Switch Toggle On-Off SPST	30303-18
Switch Temperature Control 12 Position 175-450°F	30304-22
Terminal Strip 3 Pole	30501-02
Power Cord with Molded Plug	31107-02
Transformer 120/24 VAC	31400-07
Pilot Light 208/240V 6" Lead Black Body	31601-01
Circuit Board Temperature Control	40101-19
Probe Temperature Sensor	41100-21
Grooved Griddle Cleaning Tool	50100-05
Grooved Griddle Cleaning Tool – Replacement Fingers	50100-051
Grooved Griddle Cleaning Tool – Replacement Blades	50100-052
Panel Label	60301-29
Catch Magnetic Door	70602-06
Knob Temperature Control	70701-28
Spacer Support 1/2" Nylon	70801-07
Silicon Nipple 7mm	70801-10
Burner "J" Tube Steel	80002-09-1
Burner "J" Tube Steel Left Hand Section	80002-07-1
Spark Module Ignitor	60101-910
DSI Electrode Assembly	80302-05
Orifice Main Burner #42 DRL NG	80400-11
Orifice Main Burner #53 DRL LP	80400-12
Regulator Gas Set 5" NG Griddle	80501-04
Regulator Gas Set 10" LP Griddle	80501-05
Regulator Gas Spring Conversion Kit NG to LP	80501-07
Valve Solenoid Gas 24 VAC	80502-03
Wire Harness #1 (Sense/Spark)	EZG-701
Wire Harness #2	EZG-705

## AGC

### GAS CLAMSHELL

DESCRIPTION	PART NO.
Tube #1	103-14
Hood Skirt Left Side	103-193
Hood Skirt Right Side	103-194
Hood Skirt Front Side w/ Hinge	103-197
Spark Cover	103-3
<b>Tube #2</b>	103-61
Tube #3	103-64
Tube #4	103-70
Screw 3/8" x 16 x 12"	20104-37
Motor 120V	30200-44
Switch Mercury Tilt	30307-01
Clip Mount Mercury Tilt Switch	30307-02
Switch Air w/ 1/4" Hosebarb	30308-01
Terminal Strip 3 Pole	30501-02
Relay 24 VAC	30600-04
Power Cord with Molded Plug	31107-06
Transformer 120/24 VAC	31400-07
Cap. Blower Start	40704-04
Wire Guard	50201-08
Spring Compression Inner	51002-05
Hood Spring AGC	51002-11
Burner Tile Assembly	51100-59
Hood Wrap	60101-851
Flapper	60102-191
Union Elbow 90 Degrees	70101-28
Brass Tube Tee	70101-50
Fitting 1/4" HP to 1/2" NPT	70101-61
Hose Flex Gas 27" 1/2" NPT	70101-62
Bronze Bearing 5/8" ID x 3/4" OD x 5/8" Lg	70201-06
Bronze Bearing 5/8" ID x 3/4" OD x 1" Lg	70201-07
Conduit Connector 3/8" Flex	70505-06
Conduit Connector 3/8" 90° Flex	70505-07
Handle	70603-24
Hose 1/4" Neoprene Low Pressure	74001-01
Spark Module	80300-10
Igniter & Sensor Assembly	80302-06
Pilot Orifice Enrichment Tube	80401-05
90 Degree Fitting w/ #29 DRL NG	80403-04
90 Degree Fitting w/ #44 DRL LP	80403-05
Regulator Gas Set 3 1/2" NG	80501-10
Valve Solenoid Gas 24V	80502-03
Seal Fiber	GCH-232-1
Washer AGC	GCH-232-2
Spark Wire	GCH-515-1
Sensor Wire	GCH-516-1