

# **Lang**<sup>®</sup>

**Installation**

**Operation**

**Maintenance**

**Troubleshooting**

**Model: CSG24**

Add-on Clamshell<sup>®</sup> Hood



**THIS MANUAL MUST BE RETAINED FOR FUTURE REFERENCE. READ, UNDERSTAND AND FOLLOW THE INSTRUCTIONS AND WARNINGS CONTAINED IN THIS MANUAL.**

**FOR YOUR SAFETY**  
**DO NOT STORE OR USE GASOLINE OR OTHER FLAMMABLE VAPORS AND LIQUIDS IN THE VICINITY OF THIS OR ANY OTHER APPLIANCE.**  
**POST IN A PROMINENT LOCATION**  
**INSTRUCTIONS TO BE FOLLOWED IN THE EVENT USER SMELLS GAS. THIS INFORMATION SHALL BE OBTAINED BY CONSULTING YOUR LOCAL GAS SUPPLIER. AS A MINIMUM, TURN OFF THE GAS AND CALL YOUR GAS COMPANY AND YOUR AUTHORIZED SERVICE AGENT. EVACUATE ALL PERSONNEL FROM THE AREA.**

**WARNING: IMPROPER INSTALLATION, ADJUSTMENT, ALTERATION, SERVICE OR MAINTENANCE CAN CAUSE PROPERTY DAMAGE, INJURY OR DEATH. READ THE INSTALLATION, OPERATING AND MAINTENANCE INSTRUCTIONS THOROUGHLY BEFORE INSTALLING OR SERVICING THIS EQUIPMENT.**

<b>Model #:</b>	<b>Purchased From:</b>
<b>Serial #:</b>	<b>Location:</b>
<b>Date Purchased:</b>	<b>Date Installed:</b>
<b>Purchase Order #:</b>	<b>For Service, Call:</b>

## TABLE OF CONTENTS

---

---

<u>CHAPTER</u>	<u>PAGE</u>
1. READ FIRST .....	4
2. EQUIPMENT DESCRIPTION.....	6
3. UNPACKING .....	7
4. INSTALLATION .....	8
5. INITIAL START-UP .....	10
6. OPERATION.....	11
7. SEQUENCE OF OPERATION .....	12
8. CLEANING & MAINTENANCE PROCEDURES.....	13
9. TROUBLESHOOTING .....	14
10. PARTS LISTS.....	16
11. WIRING DIAGRAMS .....	18

**NOTICE:** If the Clamshell® is to be attached to a griddle/ charbroiler in the field – it is recommended to complete the installation of mounting adapter before un-crating the Clamshell®.

**CAUTION:** UNIT IS EXTREMELY HEAVY. FOR SAFE HANDLING, INSTALLER SHOULD OBTAIN HELP AS NEEDED, OR EMPLOY APPROPRIATE MATERIALS HANDLING EQUIPMENT (SUCH AS A FORKLIFT, DOLLY, OR PALLET JACK) TO REMOVE THE UNIT FROM THE SKID AND MOVE IT TO THE PLACE OF INSTALLATION.

**WARNING:** INSTALLATION OF THE UNIT MUST BE DONE BY PERSONNEL QUALIFIED TO WORK WITH ELECTRICITY AND PLUMBING. IMPROPER INSTALLATION CAN CAUSE INJURY TO PERSONNEL AND/OR DAMAGE TO EQUIPMENT. UNIT MUST BE INSTALLED IN ACCORDANCE WITH ALL APPLICABLE CODES.

**NOTICE:** The installation of this unit must conform to applicable National, State and locally recognized installation standards.

**CAUTION:** SHIPPING STRAPS ARE UNDER TENSION AND CAN SNAP BACK WHEN CUT.

**DANGER:** DO NOT REMOVE THE MOUNTING NUTS OFF OF THE MOUNTING PLATE STUDS WHILE THE UNIT IS IN THE LOWERED POSITION. THE STANCHION BACK IS UNDER TENSION AND CAN CAUSE BODILY INJURY.

**NOTICE:** The data plate is located on the inside surface of the hood wrap. The Clamshell® voltage, wattage, serial number, clearance and gas specifications are on the data plate. This information should be carefully read and understood before proceeding with the installation.

**NOTICE:** This unit is approved to be installed only on equipment which meets NSF standards, and for which the adapter kit is provided.

**WARNING:** BEFORE LIGHTING, USE A SOAP AND WATER SOLUTION TO TEST ALL JOINTS FOR GAS LEAKS.

**NOTICE:** The installation of any components such as a vent hood, grease extractors, fire extinguisher systems, must conform to their applicable National, State and locally recognized installation standards.

**WARNING:** DURING INITIAL USE, OR USE AFTER SERVICE, IF THE PILOT DOES NOT IGNITE ON FIRST TRY THE MAIN GAS VALVE MUST BE TURNED OFF FOR AT LEAST FIVE MINUTES.

**CAUTION:** ALWAYS KEEP THE AREA NEAR THE APPLIANCE FREE FROM COMBUSTIBLE MATERIALS.

**CAUTION:** KEEP FLOOR IN FRONT OF EQUIPMENT CLEAN AND DRY. IF SPILLS OCCUR, CLEAN IMMEDIATELY, TO AVOID THE DANGER OF SLIPS OR FALLS.

**NOTICE:** While cooking, the Clamshell® must be monitored at all times. Do not leave the Clamshell® unattended while cooking.

**NOTICE:** Fan in Clamshell® runs continuously. For the safety of the unit, the fan must run continuously to provide cooling to the electrical components. Component cooling is required if the base unit is running. If power to the Clamshell® is turned off, gas to base will be turned off. If it is necessary to remove power from the Clamshell®, the base unit must be cooled below 200°F first.

**WARNING:** KEEP WATER AND SOLUTIONS OUT OF CONTROLS. NEVER SPRAY OR HOSE CONTROL CONSOLE, ELECTRICAL CONNECTIONS, ETC.

**CAUTION:** MOST CLEANERS ARE HARMFUL TO THE SKIN, EYES, MUCOUS MEMBRANES AND CLOTHING. PRECAUTIONS SHOULD BE TAKEN TO WEAR RUBBER GLOVES, GOGGLES OR FACE SHIELD AND PROTECTIVE CLOTHING. CAREFULLY READ THE WARNING AND FOLLOW THE DIRECTIONS ON THE LABEL OF THE CLEANER TO BE USED.

**CAUTION:** A COMMERCIAL LIQUID GRIDDLE CLEANER IS NOT RECOMMENDED FOR CLEANING THE GRIDDLE OR CHARBROILER UNDER THE CLAMSHELL® AS MOST CONTAIN POTASSIUM HYDROXIDE OR SODIUM HYDROXIDE WHICH IS HARMFUL TO THE CLAMSHELL® BURNER TILES.

**NOTICE:** Do not spray any liquids on to the tiles, or wipe the tiles with any materials. Liquids and direct contact on the tiles can damage them.

**CAUTION:** DO NOT USE YOUR HAND TO CHECK GRIDDLE/CHARBROILER TEMPERATURE.

**NOTICE:** Service on this, or any other, LANG appliance must be performed by qualified personnel only. Consult your LANG authorized service agent directory or call the factory at 1-800-438-5264, or WWW.LANGWORLD.COM for the service agent nearest you.

**DANGER:** BOTH HIGH AND LOW VOLTAGES ARE PRESENT INSIDE THIS APPLIANCE WHEN THE UNIT IS PLUGGED/WIRED INTO A LIVE RECEPTACLE. BEFORE PERFORMING ANY WORK ON INTERNAL COMPONENTS, DISCONNECT THE APPLIANCE FROM THE ELECTRIC POWER SUPPLY.

**CAUTION:** USE OF ANY REPLACEMENT PARTS OTHER THAN THOSE SUPPLIED BY LANG OR THEIR AUTHORIZED DISTRIBUTORS CAN CAUSE BODILY INJURY TO THE OPERATOR AND DAMAGE TO THE EQUIPMENT AND WILL VOID ALL WARRANTIES.

**CAUTION:** BE SURE ALL OPERATORS READ, UNDERSTAND AND FOLLOW THE OPERATING INSTRUCTIONS, CAUTIONS AND SAFETY INSTRUCTIONS CONTAINED IN THIS MANUAL.

**WARNING:** WHEN MULTIPLE CLAMSHELLS® ARE USED ON A GRIDDLE, ALL THE CLAMSHELLS MUST BE CONNECTED TO THE SAME 120V SOURCE.

## **2. EQUIPMENT DESCRIPTION**

---

---

### **Lang Model: CSG24**

#### **ADD-ON CLAMSHELL® HOOD**

##### **2.1 Exterior Construction**

- The Clamshell® dimensions are 19 1/2" (49.53cm) High in the lowered position, 38 1/3" (97.36cm) High in the raised position, 36 3/4" (93.35cm) Deep, and width is 24" (60.96cm).
- The stainless steel hood makes for easy cleaning.
- Pivoting heat deflector redirects excess grill heat to either side of the equipment and away from employees.

##### **2.2 Operation**

- By heating only when in the down position, you can conserve energy and save money with a cooler backroom environment.
- Cook different products at the same time with no height adjustments needed.

##### **2.3 Technical**

- Griddle operates on either Natural Gas or Propane. **This must be specified when ordering.** It is shipped with a Power Cord and Plug attached.
- Clearances required from non-combustible surfaces: Back: 0 inches, Sides: maintain side clearance of base appliance or 3 inches which ever is greater, Bottom: 6 inches below the bottom of the stanchions.

##### **2.4 Griddle Gas and Voltage Specifications**

The Lang Clamshell® can be connected to any 120 Volt source. In applications where multiple clamshells are installed on the same griddle, they all need to be plugged into the same receptacle circuit.

The gas specifications are listed on the data label located on the inside surface of the hood wrap.

**WARNING: WHEN MULTIPLE CLAMSHELLS® ARE USED ON A GRIDDLE, ALL THE CLAMSHELLS MUST BE CONNECTED TO THE SAME 120V SOURCE.**

---

---

## 3. UNPACKING

### 3.1 Receiving the Clamshell®

Upon receipt, check for freight damage, both visible and concealed. Visible damage should be noted on the freight bill at the time of delivery and signed by the carrier's agent. Concealed loss or damage means loss or damage which does not become apparent until the merchandise has been unpacked. If concealed loss or damage is discovered upon unpacking, make a written request for inspection by the carrier's agent within 15 days of delivery. All packing material should be kept for inspection. **Do not return damaged merchandise to Star Manufacturing International. File your claim with the carrier.**

### 3.2 Location

Prior to un-crating, move the Clamshell® as near to its intended location as practical. The crating will help protect the unit from physical damage normally associated with moving it through hallways and doorways.

**NOTICE:**           **If the Clamshell® is to be attached to a griddle/ charbroiler in the field – it is recommended to complete the installation of mounting adapter before un-crating the Clamshell®.**

### 3.3 Un-crating the Add-on Clamshell® Hood

If Clamshell® is received already attached to a Griddle/Charbroiler skip to section 3.4.

The Clamshell® will arrive completely assembled inside a wood frame covered by a cardboard box and bolted to a skid. **Remove the cardboard cover, unbolt Clamshell® from the support brackets. Discard the skid and brackets.**

Remove Clamshell® from skid and place in intended location.

There are several parts that are not installed in the unit. Be careful not to misplace the following parts when un-crating the unit.

- Inner Component Cover
- Outer Component Cover
- Inner Flue
- Outer Flue
- Insulation
- Manual Shut-off Valve
- Two 3/8 X 16 Nuts

Note: See Mounting Adapter kit for instructions on installing these parts.

**CAUTION:**           **UNIT IS EXTREMELY HEAVY. FOR SAFE HANDLING, INSTALLER SHOULD OBTAIN HELP AS NEEDED, OR EMPLOY APPROPRIATE MATERIALS HANDLING EQUIPMENT (SUCH AS A FORKLIFT, DOLLY, OR PALLET JACK) TO REMOVE THE UNIT FROM THE SKID AND MOVE IT TO THE PLACE OF INSTALLATION.**

### 3.4 Un-crating Griddle/Charbroiler with Clamshell® Attached

**CAUTION:**           **SHIPPING STRAPS ARE UNDER TENSION AND CAN SNAP BACK WHEN CUT.**

The griddle will arrive completely assembled inside a wood frame covered by a cardboard box and strapped to a skid. **Remove the cardboard cover, cut the straps and remove the wood frame.**

Remove griddle from skid and place in intended location. The legs and gas regulator are located in the grease drawer.

## 4. INSTALLATION

---

---

**WARNING:** INSTALLATION OF THE UNIT MUST BE DONE BY PERSONNEL QUALIFIED TO WORK WITH ELECTRICITY AND PLUMBING. IMPROPER INSTALLATION CAN CAUSE INJURY TO PERSONNEL AND/OR DAMAGE TO EQUIPMENT. UNIT MUST BE INSTALLED IN ACCORDANCE WITH ALL APPLICABLE CODES.

**NOTICE:** The data plate is located on the inside of the hood wrap. The Clamshell® voltage, wattage, serial number, clearance and gas specifications are on the data plate. This information should be carefully read and understood before proceeding with the installation.

**NOTICE:** This unit is approved to be installed only on equipment which meets NSF standards, and for which the adapter kit is provided.

**WARNING:** WHEN MULTIPLE CLAMSHELLS® ARE USED ON A GRIDDLE, ALL THE CLAMSHELLS MUST BE CONNECTED TO THE SAME 120V SOURCE.

### 4.1 Electrical Connection

The Clamshell® is supplied with a cord and plug. The receptacle is not provided with the Clamshell®. Follow the receptacle manufacturer's instructions when connecting the receptacle to the power supply. When multiple Clamshells are installed on the same griddle, you must plug them into the same electrical circuit (receptacle) to prevent from doing damage to the units transformers.

### 4.2 Gas Connection

**WARNING:** BEFORE LIGHTING, USE A SOAP AND WATER SOLUTION TO TEST ALL JOINTS FOR GAS LEAKS.

This Clamshell® is manufactured for use with the type of gas indicated on the nameplate. Contact the factory if your type of gas does not match the nameplate data.

All gas connectors must be in accordance with local codes and comply with the National Fuel Federal Gas Codes ANSI Z223.1 latest edition.

There are two gas connections involved in the installation of the Clamshell®:

The first is the gas supply to the Clamshell® itself. This connection should be made positioning the manual shut-off valve supplied with the Clamshell® to isolate the appliance from the kitchen's main gas supply during any future service activity (See figure 1). (A service agent should be able to shutoff and disconnect the gas supply to the Clamshell® without affecting the main gas supply to the kitchen.) Use gas lines that have a minimum diameter of at least 1/2 an inch.

The second is the gas supply to the base appliance (the appliance to which the Clamshell® is mounted). The Clamshell® has an external solenoid valve (the Automatic Cutoff Valve (ACV)) at the end of a flexible conduit. The ACV must be installed in line with the gas supply to the base appliance in a location, which will ensure the ACV is not exposed to temperatures above 175°F (See figure 1). Remove the cover to the ACV to ensure the correct flow direction through the valve when making the connections. Replace the cover after the connections are complete. Use gas lines that have a minimum diameter of at least 1/2 an inch.

**NOTE:** If this Clamshell® is received already mounted on a Lang griddle no further installation is required. If this Clamshell® is a separate unit proceed to section 4.3 below.

**NOTICE:** The installation of any components such as a vent hood, grease extractors, fire extinguisher systems, must conform to their applicable National, State and locally recognized installation standards.



## 4. INSTALLATION CONT'D

### 4.3 Installation Instructions

Refer to the Installation instructions provided with the adapter kit, on how to connect this Clamshell® to the griddle/charbroiler.

Figure 1

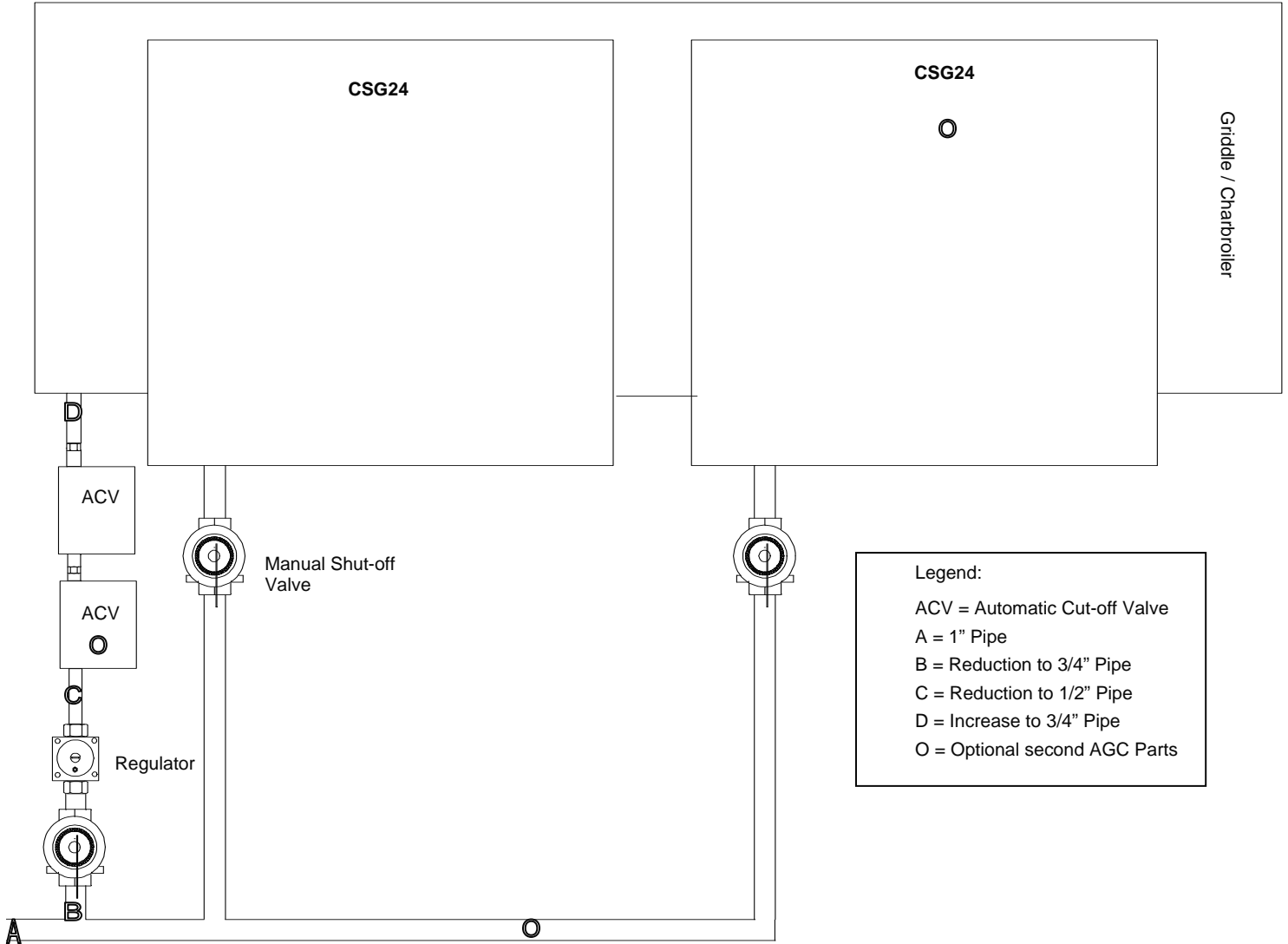

## 5. INITIAL START UP

---

### 5.1 Initial Lighting Procedure for an Clamshell®

**WARNING:** DURING INITIAL USE, OR USE AFTER SERVICE, IF THE PILOT DOES NOT IGNITE ON FIRST TRY THE MAIN GAS VALVE MUST BE TURNED OFF FOR AT LEAST FIVE MINUTES.

**NOTICE:** While cooking, the Clamshell® must be monitored at all times. DO NOT leave the Clamshell® unattended while cooking.

**NOTICE:** Fan in Clamshell® runs continuously. For the safety of the unit, the fan must run continuously to provide cooling to the electrical components. Component cooling is required if the base unit is running. If power to the Clamshell® is turned off, gas to base will be turned off. If it is necessary to remove power from the Clamshell®, the base unit must be cooled below 200°F first.

- The Clamshell® has two positions, the lowered position for cooking and the raised position for griddle loading, cleaning, or griddle only use.
- No thermostats are provided for temperature control. The Clamshell® is a radiant cooking device, which operates only in the lowered position.
- Ignition is automatic and occurs as the Clamshell® is lowered.
- Raising the Clamshell® turns the gas burner off.

### 5.2 Initial Lighting Procedure for the Griddle/Charbroiler

See Operator manual for the griddle/charbroiler.

---

---

## 6. OPERATION

### 6.1 Clamshell® Operation

**CAUTION:** ALWAYS KEEP THE AREA NEAR THE APPLIANCE FREE FROM COMBUSTIBLE MATERIALS.

**CAUTION:** KEEP FLOOR IN FRONT OF EQUIPMENT CLEAN AND DRY. IF SPILLS OCCUR, CLEAN IMMEDIATELY, TO AVOID THE DANGER OF SLIPS OR FALLS.

**NOTICE:** While cooking, the Clamshell® must be monitored at all times. Do not leave the Clamshell® unattended while cooking.

- The Clamshell® has two positions, the lowered position for cooking and the raised position for griddle loading, cleaning, or griddle only use.
- No thermostats are provided for temperature control. The Clamshell® is a radiant cooking device, which operates only in the lowered position.
- Ignition is automatic and occurs as the Clamshell® is lowered.
- Raising the Clamshell® turns the gas burner off.
- Place food on griddle/charbroiler and immediately lower the Clamshell®. The tiles will glow reddish-orange in approximately 30-45 seconds. The radiant heat from the Clamshell® will cook from the top while the griddle/charbroiler cooks the product from the bottom.
- Load product under the Clamshell® following the normal loading procedures for the griddle/charbroiler to which it is attached.

### 6.2 Operation When Attached to a Griddle/Charbroiler

See Operator's Manual for the base unit.

## 7. SEQUENCE OF OPERATION

---

---

### 7.1 Power On

- When the Clamshell® is plugged in, 115 Volts is applied to the blower motor. **The Clamshell® is designed to have a constantly running blower motor.**
- The air switch then senses the blower motor, closes, and applies the 115 Volts to a 24 VAC transformer.
- The transformer then supplies 24 VAC to the tilt switch, and to the automatic cutoff valve.
- The 24 VAC to the automatic cutoff valve opens the gas valve to the griddle/charbroiler, thus allowing the base unit to operate.
- When the Clamshell® is lowered, the tilt switch allows 24 VAC to go to the spark module.
- The spark module then supplies 24 VAC to open the Clamshell® gas valve, and high voltage to the spark igniter.
- When the burner ignites, the sense probe senses the flame is ignited and the spark module turns off the high voltage to the spark igniter.
- When the Clamshell® is raised the tilt switch opens the 24 VAC to the spark module, which removes the 24 VAC to the gas valve, turning off the Clamshell®.

## 8. MAINTENANCE & CLEANING

---

---

**WARNING:** KEEP WATER AND SOLUTIONS OUT OF CONTROLS. NEVER SPRAY OR HOSE CONTROL CONSOLE, ELECTRICAL CONNECTIONS, ETC.

**CAUTION:** MOST CLEANERS ARE HARMFUL TO THE SKIN, EYES, MUCOUS MEMBRANES AND CLOTHING. PRECAUTIONS SHOULD BE TAKEN TO WEAR RUBBER GLOVES, GOGGLES OR FACE SHIELD AND PROTECTIVE CLOTHING. CAREFULLY READ THE WARNING AND FOLLOW THE DIRECTIONS ON THE LABEL OF THE CLEANER TO BE USED.

**CAUTION:** A COMMERCIAL LIQUID GRIDDLE CLEANER IS NOT RECOMMENDED FOR CLEANING THE GRIDDLE OR CHARBROILER UNDER THE CLAMSHELL® AS MOST CONTAIN POTASSIUM HYDROXIDE OR SODIUM HYDROXIDE WHICH IS HARMFUL TO THE CLAMSHELL® BURNER TILES.

**NOTICE:** Do not spray any liquids on to the tiles, or wipe the tiles with any materials. Liquids and direct contact on the tiles can damage them.

### 8.1 Weekly Cleaning

- The Clamshell® tiles are self cleaning, which is accomplished by leaving the Clamshell® on with no product being cooked, thus allowing the heat of the broiler to burn debris from the tiles.
- To clean the Clamshell®, start with a clean griddle plate.
- Turn off the griddle/charbroiler thermostats and wait until the griddle/charbroiler is cool.

**CAUTION:** DO NOT USE YOUR HAND TO CHECK GRIDDLE/CHARBROILER TEMPERATURE.

- Lower the Clamshell® and let it run for 45 minutes, then raise the Clamshell® and ensure the blower motor continues to blow cooling air through the burner tiles (Do not unplug or turn off Clamshell® power).
- Once the Clamshell® has cooled, wipe ash from around the burner tiles. Take care not to touch the burner tiles with the cleaning rag.

**NOTICE:** Do not spray any liquids on to the tiles, or wipe the tiles with any materials. Liquids and direct contact on the tiles can damage them.

### 8.2 Burner Air Shutter Adjustment

- The air shutters are pre-set at the factory, and should not need adjustment. However, if adjustments are being required, contact your local authorized service station for instructions.

### 8.3 Disconnecting Power from Blower Motor

If power is to be removed from the blower motor, the following must be completed:

- The gas to the base unit and the gas to the Clamshell® must be turned off.

**The base unit must be cooled below 200°F.**

---

---

## 8. MAINTENANCE & CLEANING CONTINUED

---

**CAUTION:** DO NOT REMOVE THE REAR DRIP SHIELD. THE DRIP SHIELD SHOULD ONLY BE REMOVED DURING SPECIFIC REPAIRS BY A TRAINED SERVICE PROFESSIONAL.

Do not remove the drip shields. The drip shields should only be removed during specific repairs by a trained service professional. Check the screws on your unit during your periodic inspection.

- If you cannot turn a screw to the left or counter-clockwise, then do not do anything further with that screw.
- If you can turn a screw to the left or counter-clockwise, then use the Lang kit, part number PS-60101-W8, provided to you at no charge to rework the screw.

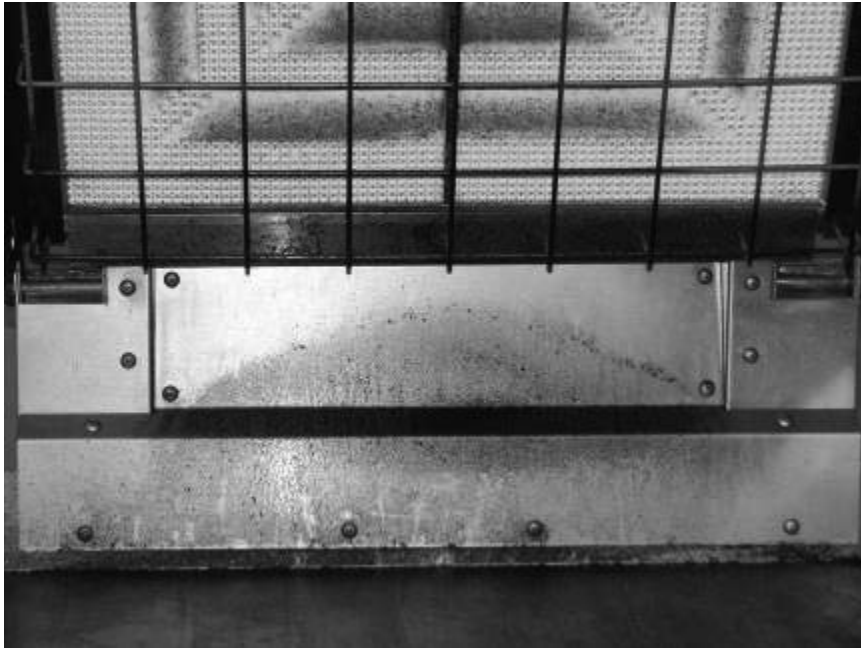

## 9. TROUBLESHOOTING

### 9.1 Symptoms

What follows is a chart of Symptoms and Possible Causes to aid in diagnosing faults with the Clamshell®. Refer to the Symptoms column to locate the type of failure then to the Possible Cause for the items to be checked.

To test for a possible cause, refer to the TEST section and locate the Possible Cause then refer to test to identify test procedures.

SYMPTON	POSSIBLE CAUSE
Igniter not sparking	<ul style="list-style-type: none"> <li>• Failed spark module</li> <li>• Failed tilt switch</li> <li>• Failed air switch</li> <li>• Failed motor blower</li> <li>• Failed transformer</li> <li>• Failed spark electrode</li> </ul>
Spark but no ignition	<ul style="list-style-type: none"> <li>• Failed spark controller</li> <li>• Failed gas solenoid valve</li> <li>• Clamshell® gas valve turned off</li> <li>• Plugged orifice</li> </ul>
Clamshell® turns off after extended use	<ul style="list-style-type: none"> <li>• Incorrectly adjusted sense electrode</li> </ul>
Taking too long to light	<ul style="list-style-type: none"> <li>• Incorrectly adjusted spark electrode</li> <li>• Plugged enrichment orifice</li> <li>• Plugged burner tiles</li> </ul>
Hazy blue flame on tile face	<ul style="list-style-type: none"> <li>• Incorrectly adjusted air shutter</li> <li>• Leak in air path to burner face</li> <li>• Incorrectly adjusted gas regulator</li> </ul>
Not hot enough	<ul style="list-style-type: none"> <li>• Incorrectly adjusted gas regulator</li> <li>• Plugged main burner orifice</li> <li>• Plugged burner tiles</li> </ul>
Clamshell® not turning off	<ul style="list-style-type: none"> <li>• Failed tilt switch</li> <li>• Failed gas solenoid valve</li> </ul>
Blower runs continuously	<ul style="list-style-type: none"> <li>• Normal operation</li> </ul>

## 9. TROUBLESHOOTING CONT'D

### 9.2 TESTS

**NOTICE:** Service on this, or any other, LANG appliance must be performed by qualified personnel only. Consult your LANG authorized service agent directory or call the factory at 1-800-807-9054, or WWW.STAR-MFG.COM For the service agent nearest you.

**WARNING:** BOTH HIGH AND LOW VOLTAGES ARE PRESENT INSIDE THIS APPLIANCE WHEN THE UNIT IS PLUGGED/WIRED INTO A LIVE RECEPTACLE. BEFORE REPLACING ANY PARTS, DISCONNECT THE UNIT FROM THE ELECTRIC POWER SUPPLY AND CLOSE THE MAIN GAS VALVE. ALLOW FIVE MINUTES FOR UNBURNED GAS TO VENT.

If an item on the list is followed by an asterisk (\*), the work should be done by a factory authorized service representative.

Possible Cause	TEST
Failed tilt switch	<ul style="list-style-type: none"><li>• Unplug switch and test for continuity while raising/lowering the hood</li></ul>
Failed gas valve	<ul style="list-style-type: none"><li>• Remove the wires and check for continuity across the valve coil</li></ul>
Failed spark module	<ul style="list-style-type: none"><li>• Check for 24 VAC on TH*</li><li>• Observe spark</li></ul>
Failed air switch	<ul style="list-style-type: none"><li>• Unplug switch and test for continuity while blower motor is running*</li></ul>
Failed combustion blower	<ul style="list-style-type: none"><li>• Check for proper voltage to unit/blower*</li><li>• Check for continuity across the motor's windings</li></ul>
Improper gas pressure	<ul style="list-style-type: none"><li>• Ensure gas pressure is adjusted properly*</li></ul>
Failed transformer	<ul style="list-style-type: none"><li>• Check for proper voltage*</li></ul>

**CAUTION:** USE OF ANY REPLACEMENT PARTS OTHER THAN THOSE SUPPLIED BY LANG OR THEIR AUTHORIZED DISTRIBUTORS CAN CAUSE BODILY INJURY TO THE OPERATOR AND DAMAGE TO THE EQUIPMENT AND WILL VOID ALL WARRANTIES.



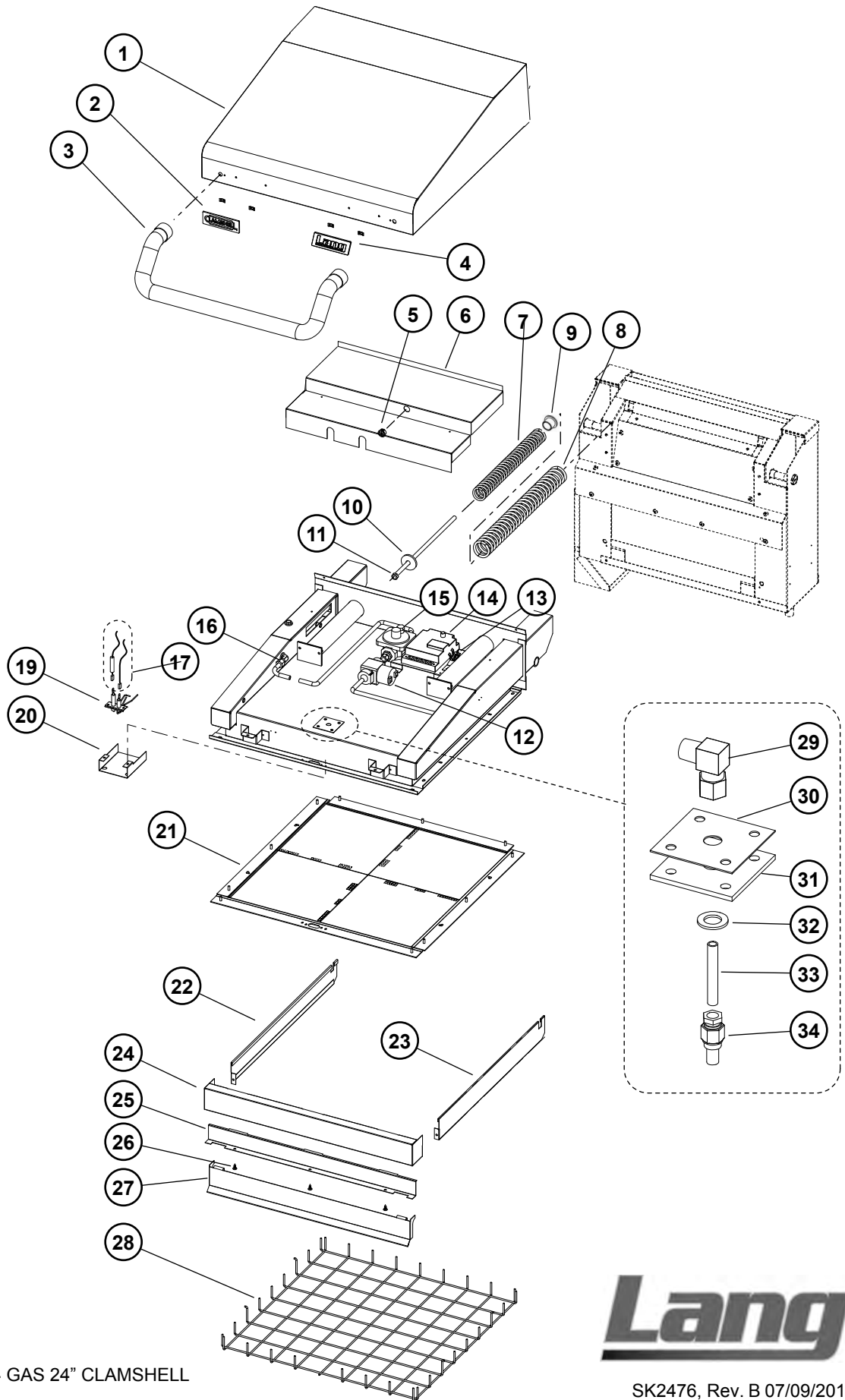

Model: CSG24 GAS 24" CLAMSHELL

**Lang**

SK2476, Rev. B 07/09/2018

# PARTS LIST

JULY 09, 2018, Rev. A

Gas Clamshell Hood Parts List				
Fig No	Part No	Qty	Description	Application
1	K9-60101-851	1	HOOD WRAP ASSY, w/DIE CAST LOGOS	
2	2M-60301-W2	1	LANG CLAMSHELL LOGO	
3	K9-70603-24	1	AGC HOOD HANDLE ASSY COMPLETE	
4	K9-60301-43-1	1	SATIN CHR-M-LANG DIE CAST	
5	2K-70801-19	1	BUSHING HEYCO 5/8#2077	
6				
7	2P-51002-11	2	HOOD SPRING	
8	2P-51002-05	2	SPRING GAS HOOD	
9	2P-70201-06	2	BRNZ BR FLN BUSHING	
10	K9-50312-40	2	SPRING PISTON / WASHER	
11	2C-20104-37	2	SCRW 3/8-16X12 H/H CAP 2 THD	
12	2V-80502-03	1	SOLENOID VALVE 24VAC 1/2PIPE	CSG24
		2		CSG24B
13	K9-30307-01	1	SWT MERC TLT W/250°C 18GA	
14	2J-80300-10	1	SPRK IGN CNTRL	
15	2V-80501-03	1	GAS REG 1/2X1/2CLSISET10	LP
	2V-80501-10	1	GAS REG 1/8X1/2 CLS I	NAT
16	Y9-80403-04	1	90 DEG FITING W/#29 DRL	NAT
	2A-80400-26		ORIFICE HOOD .1360 #29	
	Y9-80403-05	1	90 DEG FITING W/#44DRL	LP
	2A-80400-27		ORIFICE HOOD .0860 #44	
17	2E-103-232	1	HARNESS, AGC HOOD #1	
19	2J-80302-06	1	IGNITOR/SENSOR CHANNEL	
20	K9-103-3	1	SPARK COVER	
21	K9-51100-59	1	BURNER TILE ASSY, GLUED	
--	2H-60106-67	1	INSULATION BURNER TILE KIT (INCLUDED w/K9-51100-59)	
22	2U-103-193	1	LEFT SKIRT	
23	2V-103-194	1	RIGHT SKIRT	
24	2V-103-197	1	FRONT SKIRT w/HINGE	
25	K9-60102-1964	1	FRONT SKIRT INNER WALL w/SCREWS	
26	2C-20103-02	3	SCRW SM PLT 10 X .5 PHLSL	
27	K9-103-A88	1	FLAPPER ASSY	
28	2B-50201-08	1	WIRE GUARD ADD-ON-BROILER	
29	2K-70101-51	1	BRAS TBE ELBOW 1/4CC X 1/4CC	
30	K9-103-4	1	TOP SEAL PLATE	
31	K9-103-89	1	TOP PLATE SEAL	
32	2C-20201-03	1	WSHR FLT AN960-716	
33	K9-103-71	1	TUBE #5	
34	2A-80401-04	1	PILOT BURNER ORIFICE, .021DRL	NAT
	2A-80401-05		PILOT BURNER ORIFICE, .010DRL	LP
NI	2H-103-124	1	COMPONENT COVER INSULATION	

**IMPORTANT: WHEN ORDERING, SPECIFY VOLTAGE OR TYPE GAS DESIRED  
INCLUDE MODEL AND SERIAL NUMBER**

PAGE 1  
OF 1

Some items are included for illustrative purposes only and in certain instances may not be available.



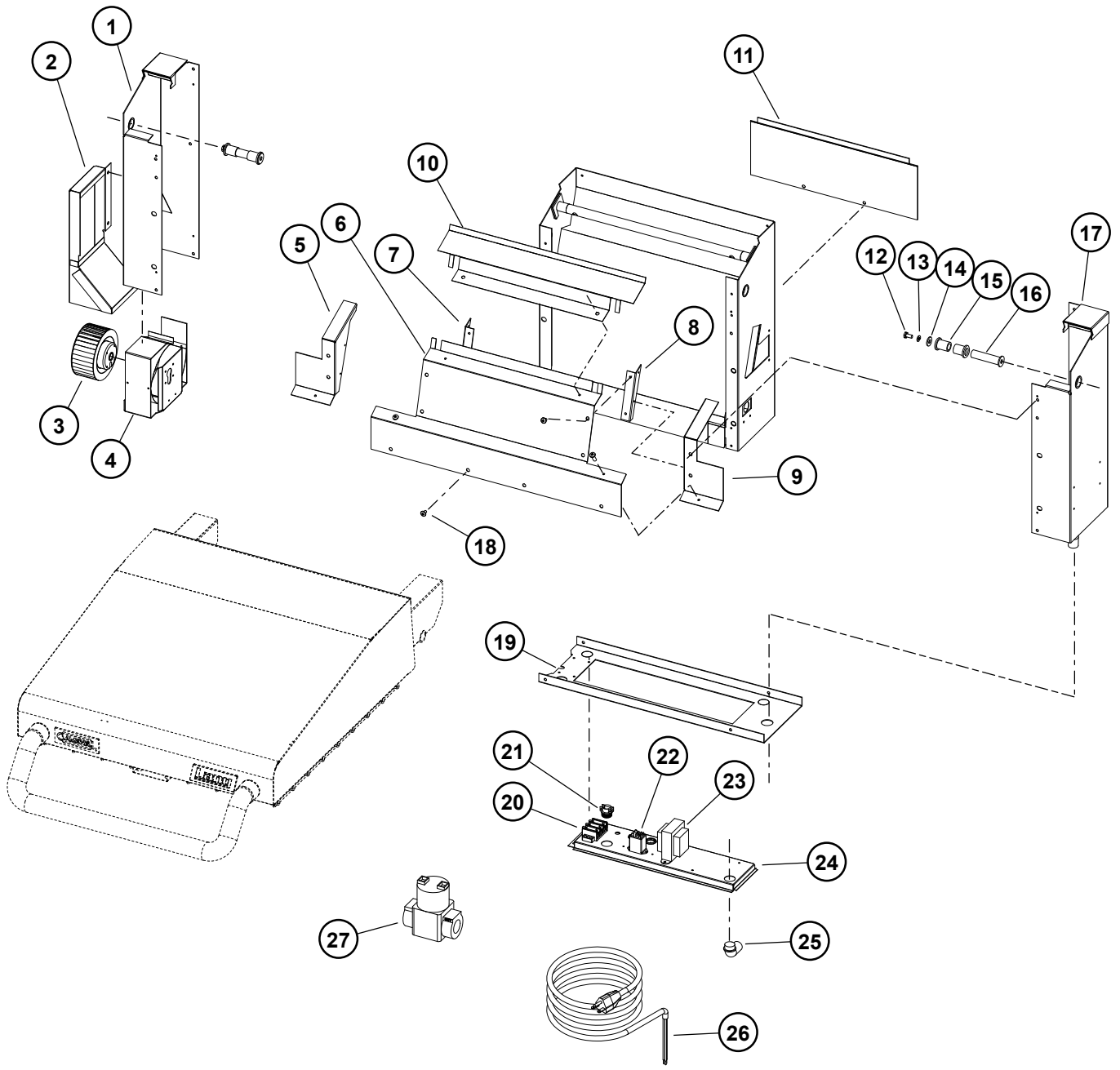

Model: CSG24 GAS 24" CLAMSHELL, FRAME ASSY

**Lang**<sup>®</sup>

SK2477, Rev. A, 3/23/2015

# PARTS LIST

August 04, 2015, Rev. -

Gas Clamshell Frame Parts List				
Fig No	Part No	Qty	Description	Application
1	K9-103-702-W2	1	LEFT OUTER STANCHION - ASSY	CSG24
	K9-103-702-1		LEFT OUTER STANCHION	CSG24B
2	K9-103-701	1	BLOWER DUCT - SPOT	
3	2U-30200-44	1	MOTOR & BLOWER ASSY FOR AGC	
4	OB-60102-194	1	OBS AGC BLOWER HOUSE ASSY	
5	K9-103-301	1	STANCHION COVER LH	CSG24
	K9-103-301-2			CSG24B
6	K9-103-303	1	INNER DRIP EDGE	CSG24
	K9-103-303-2			CSG24B
7	K9-103-304	1	BAFFLE CLIP RH	
8	K9-103-305-1	1	BAFFLE CLIP LH	
9	K9-103-300	1	STANCHION COVER RH	CSG24
	K9-103-300-2		STANCHION COVER RH	CSG24B
10	K9-103-323	1	HOODWRAP DRIP CATCHER	
11	K9-103-164	1	REAR ACCESS COVER	
12	2C-20104-08	2	SCRW HXHD CAP PLT 1/4-20	
13	2C-20202-05	2	WSHR PLT 1/4 LOCK SPLIT	
14	2C-20201-05	2	WSHR LFT 1/4 USS PLTD	
15	2P-70201-07	4	BRNZ BR FLN 5/8IDX3/4ODX1	
16	K9-60102-1911	2	HOOD PIVOT SHAFT ASSY	
17	K9-103-115-W3	1	RIGHT OUTER STANCHION	CSG24
	K9-103-115-3		RH OUTER STANCHION	CSG24B
18	2C-20109-04	16	SCREW THD MS SS 10-32X	
19	K9-103-102	1	FIXED BOTTOM	
20	2E-30501-02	1	TRM STRP 3 POLE W/PUSH ON TRM	
21	2E-31200-01	1	BOX CONNECTOR 3/8	
22	2E-30600-11	1	RELAY 120V SPDT FLANGE MNT	used w/Envirozone Griddles
	2E-30600-04		RLAY 24VAC 2FRMC DPDT FLNG MNT	
23	2E-31400-07	1	XFRMR, 120-208-240/24V,40V	
24	K9-103-101	1	COMPONENT TRAY	
25	2E-70505-07	1	CONDUIT CNNCTR 3/8 90° FLEX	
26	2E-31107-06	1	CORD SET 14/3 X 6' 15A	
27	2V-80502-03	1	SOLENOID VALVE 24VAC	
NI	2E-30308-01	1	SWITCH AIR 10WC 1/4	
NI	K9-103-95	1	AIR SWITCH HOSE	
NI	2E-40704-04	1	CAP - BLOWER START FOR	

**IMPORTANT: WHEN ORDERING, SPECIFY VOLTAGE OR TYPE GAS DESIRED  
INCLUDE MODEL AND SERIAL NUMBER**

PAGE 1  
OF 1

Some items are included for illustrative purposes only and in certain instances may not be available.



⚠ WHEN 2 OR 3 HOODS ARE PRESENT, ONLY ONE POWER CORD IS USED FOR ALL HOODS.

REV.	DATE/ECO	DESCRIPTION OF CHANGE
F	6/8/2011 ECO 10748	REDRAWN IN SOLDWORKS ADDED POWER JUMPER FOR 2ND & 3RD HOOD

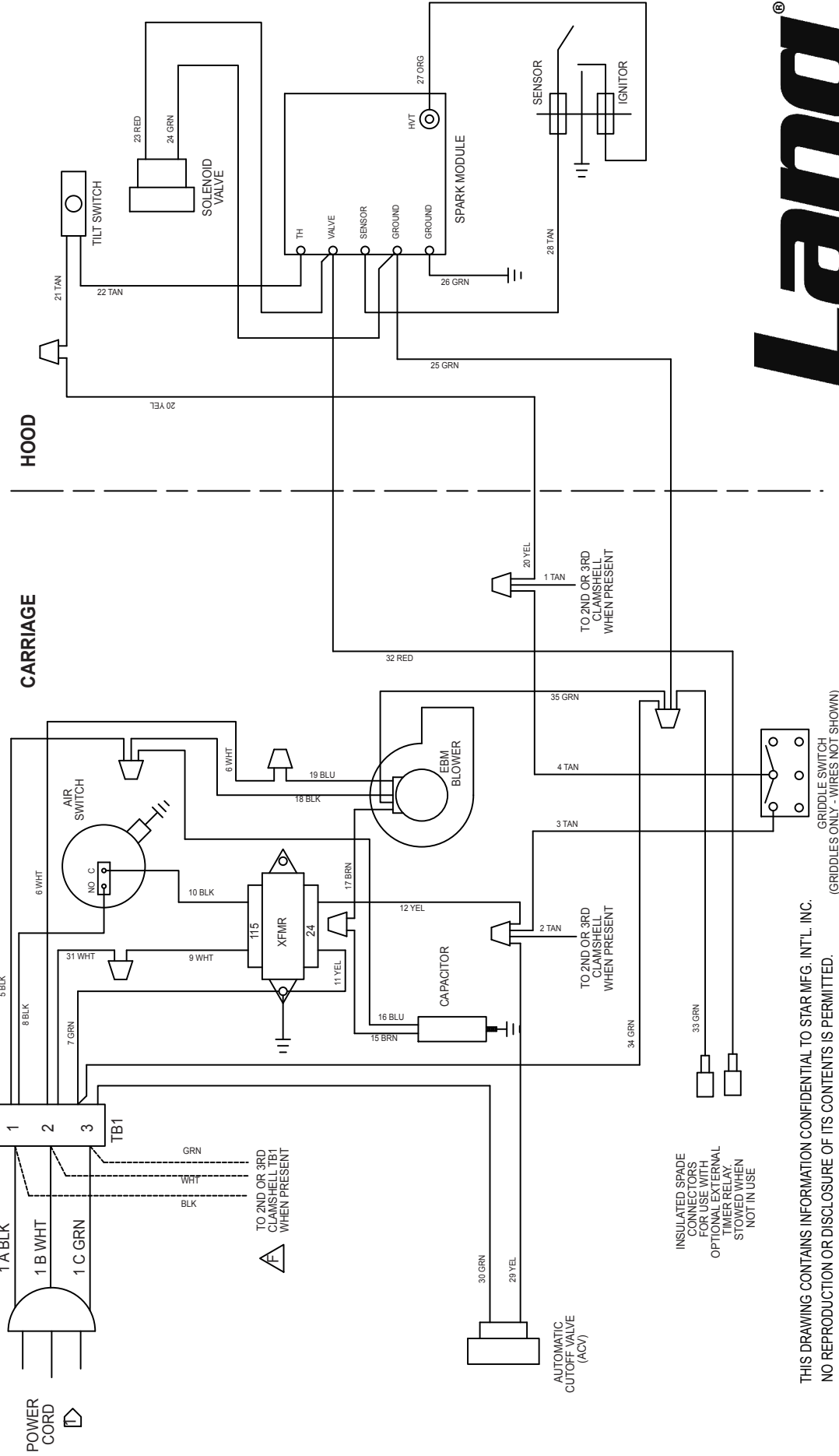

INSULATED SPADE CONNECTORS FOR USE WITH OPTIONAL EXTERNAL TIMER RELAY. STOWED WHEN NOT IN USE

THIS DRAWING CONTAINS INFORMATION CONFIDENTIAL TO STAR MFG. INT'L. INC. NO REPRODUCTION OR DISCLOSURE OF ITS CONTENTS IS PERMITTED. (GRIDDLES ONLY - WIRES NOT SHOWN)

MODELS:  
ADD ON GAS CLAMSHHELL



STAR MANUFACTURING INTERNATIONAL INC. # 10 SUNNEN DRIVE ST. LOUIS, MO. 63143, USA		MATERIAL		MODEL NO.		PART NO.	
Lang		FINISH		2M-61122-W22		2M-61122-W22	
DR: Dan Soval		DATE: 7/22/10		REV. DATE		DESCRIPTION OF CHANGE	
TOLERANCE UNLESS NOTED: .0005" / .016"		TOLERANCE UNLESS NOTED: .0005" / .016"		12/11/2007		CHANGED TAN 1, TAN 2 WIRES TO	
NO REPRODUCTION OR DISCLOSURE OF THIS DOCUMENT IS PERMITTED		NO REPRODUCTION OR DISCLOSURE OF THIS DOCUMENT IS PERMITTED		ECO 9924		DASHED & ADDED NOTE	
NO REPRODUCTION OR DISCLOSURE OF THIS DOCUMENT IS PERMITTED		NO REPRODUCTION OR DISCLOSURE OF THIS DOCUMENT IS PERMITTED		ECO 9924		ADDED NOTE 2.	

**NOTES:**  
 1. DASHED WIRES ARE ONLY REQ'D WHEN HOODS ARE USED.  
 (2) HOODS ARE USED. HOOD CORDS MUST BE PLUGGED INTO THE SAME RECEPTACLE.

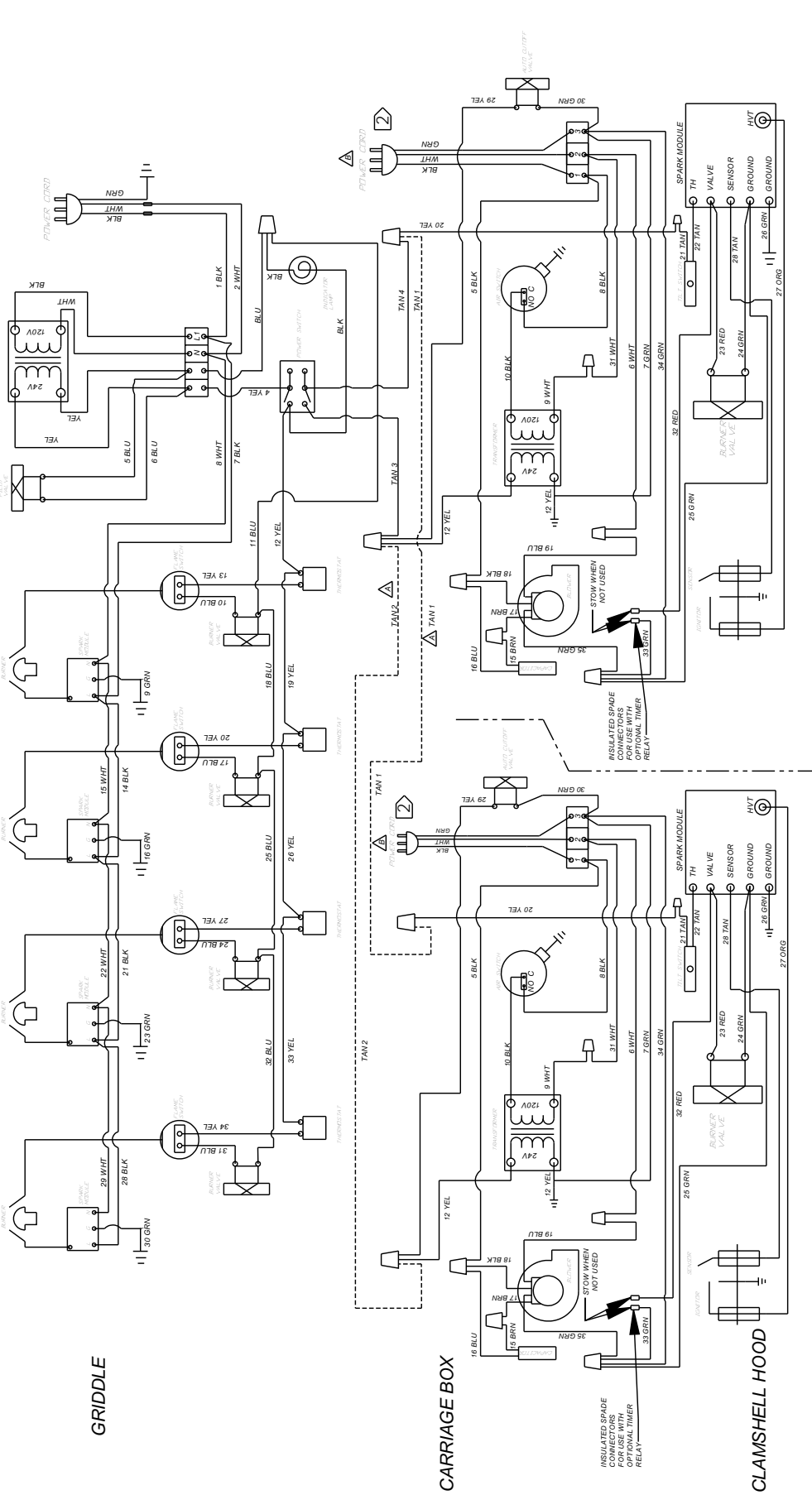

CLAMSHELL HOOD & CARRIAGE BOX 1

CLAMSHELL HOOD & CARRIAGE BOX 2 (OPTIONAL)



STAR INTERNATIONAL HOLDINGS INC. COMPANY  
Star - Holman - Lang - Wells - Bloomfield - Toastmaster  
265 HOBSON ST, SMITHVILLE, TN 37166 U.S.A.  
(800) 807-9054 (314) 781-2777  
Parts & Service (800) 807-9054  
[www.star-mfg.com](http://www.star-mfg.com)