

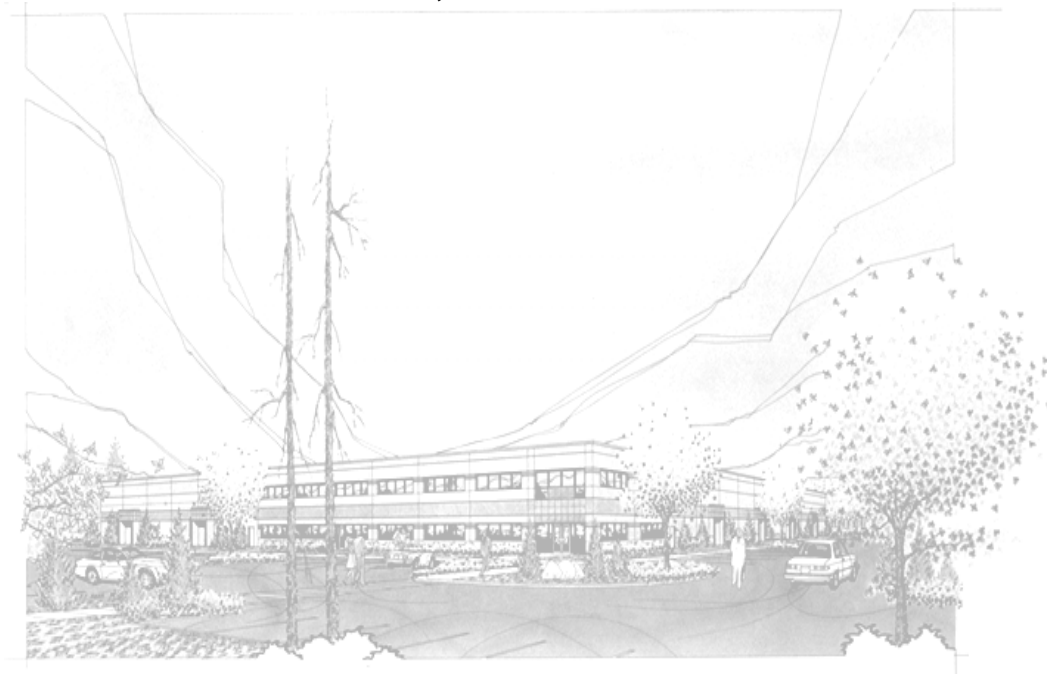

**Installation, Operation, & Maintenance**  
**Model: ECCO-PT, Electric Full Size Convection Oven**



**THIS MANUAL MUST BE RETAINED FOR FUTURE REFERENCE. READ, UNDERSTAND AND FOLLOW THE INSTRUCTIONS AND WARNINGS CONTAINED IN THIS MANUAL.**

**FOR YOUR SAFETY**  
**DO NOT STORE OR USE GASOLINE OR OTHER FLAMMABLE VAPORS AND LIQUIDS IN THE VICINITY OF THIS OR ANY OTHER APPLIANCE.**

**POST IN A PROMINENT LOCATION**  
**INSTRUCTIONS TO BE FOLLOWED IN THE EVENT USER SMELLS GAS. THIS INFORMATION SHALL BE OBTAINED BY CONSULTING YOUR LOCAL GAS SUPPLIER. AS A MINIMUM, TURN OFF THE GAS AND CALL YOUR GAS COMPANY AND YOUR AUTHORIZED SERVICE AGENT. EVACUATE ALL PERSONNEL FROM THE AREA.**

**WARNING: IMPROPER INSTALLATION, ADJUSTMENT, ALTERATION, SERVICE OR MAINTENANCE CAN CAUSE PROPERTY DAMAGE, INJURY OR DEATH. READ THE INSTALLATION, OPERATING AND MAINTENANCE INSTRUCTIONS THOROUGHLY BEFORE INSTALLING OR SERVICING THIS EQUIPMENT.**

|                          |                           |
|--------------------------|---------------------------|
| <b>Model #:</b>          | <b>Purchased From:</b>    |
| <b>Serial #:</b>         | <b>Location:</b>          |
| <b>Date Purchased:</b>   | <b>Date Installed:</b>    |
| <b>Purchase Order #:</b> | <b>For Service, Call:</b> |

# TABLE OF CONTENTS

| <b>CHAPTER</b>                          | <b>PAGE</b> |
|---|-------------|
| TABLE OF CONTENTS.....                  | 3           |
| READ FIRST.....                         | 4           |
| EQUIPMENT DESCRIPTION .....             | 6           |
| UNPACKING.....                          | 7           |
| INSTALLATION .....                      | 8           |
| INITIAL START-UP.....                   | 11          |
| OPERATION.....                          | 12          |
| MAINTENANCE & CLEANING PROCEDURES ..... | 16          |
| TROUBLE SHOOTING.....                   | 17          |
| PARTS LIST .....                        | 19          |
| WIRING DIAGRAM .....                    | 20          |
| WARRANTY .....                          | 23          |

**CAUTION:** EACH UNIT WEIGHS 430 LBS. FOR SAFE HANDLING, INSTALLER SHOULD OBTAIN HELP AS NEEDED, OR EMPLOY APPROPRIATE MATERIALS HANDLING EQUIPMENT (SUCH AS A FORKLIFT, DOLLY, OR PALLET JACK) TO REMOVE THE UNIT FROM THE SKID AND MOVE IT TO THE PLACE OF INSTALLATION.



**CAUTION:** ANY STAND, COUNTER OR OTHER DEVICE ON WHICH OVEN WILL BE LOCATED MUST BE DESIGNED TO SUPPORT THE WEIGHT OF THE OVEN.



**CAUTION:** SHIPPING STRAPS ARE UNDER TENSION AND CAN SNAP BACK WHEN CUT.



**DANGER:** THIS APPLIANCE MUST BE GROUNDED AT THE TERMINAL PROVIDED. FAILURE TO GROUND THE APPLIANCE COULD RESULT IN ELECTROCUTION AND DEATH.



**WARNING:** INSTALLATION OF THE UNIT MUST BE DONE BY PERSONNEL QUALIFIED TO WORK WITH ELECTRICITY AND PLUMBING. IMPROPER INSTALLATION CAN CAUSE INJURY TO PERSONNEL AND/OR DAMAGE TO EQUIPMENT. UNIT MUST BE INSTALLED IN ACCORDANCE WITH ALL APPLICABLE CODES.



**NOTICE:** The data plate is located above control panel behind wire mesh screen. The oven voltage, wattage, serial number, wire size, and clearance specifications are on the data plate. This information should be carefully read and understood before proceeding with the installation.



**NOTICE:** The installation of any components such as a vent hood, grease extractors, fire extinguisher systems, must conform to their applicable National, State and locally recognized installation standards.



**NOTICE:** During the first few hours of operation you may notice a small amount of smoke coming off the oven, and a faint odor from the smoke. This is normal for a new oven and will disappear after the first few hours of use.



**CAUTION:** ALWAYS KEEP THE AREA NEAR THE APPLIANCE FREE FROM COMBUSTIBLE MATERIALS.



**CAUTION:** KEEP FLOOR IN FRONT OF EQUIPMENT CLEAN AND DRY. IF SPILLS OCCUR, CLEAN IMMEDIATELY, TO AVOID THE DANGER OF SLIPS OR FALLS.



**WARNING:** KEEP WATER AND SOLUTIONS OUT OF CONTROLS. NEVER SPRAY OR HOSE CONTROL CONSOLE, ELECTRICAL CONNECTIONS, ETC.



**CAUTION:** MOST CLEANERS ARE HARMFUL TO THE SKIN, EYES, MUCOUS MEMBRANES AND CLOTHING. PRECAUTIONS SHOULD BE TAKEN TO WEAR RUBBER GLOVES, GOGGLES OR FACE SHIELD AND PROTECTIVE CLOTHING. CAREFULLY READ THE WARNING AND FOLLOW THE DIRECTIONS ON THE LABEL OF THE CLEANER TO BE USED.



**NOTICE:** Never leave a chlorine sanitizer in contact with stainless steel surfaces longer than 10 minutes. Longer contact can cause corrosion.



**NOTICE:** Service on this, or any other, LANG appliance must be performed by qualified personnel only. Consult your authorized service station directory or call the factory at 1-800-224-LANG (5264), or WWW.LANGWORLD.COM for the service station nearest you.



**WARNING:** BOTH HIGH AND LOW VOLTAGES ARE PRESENT INSIDE THIS APPLIANCE WHEN THE UNIT IS PLUGGED/WIRED INTO A LIVE RECEPTACLE. BEFORE REPLACING ANY PARTS, DISCONNECT THE UNIT FROM THE ELECTRIC POWER SUPPLY.



**CAUTION:** USE OF ANY REPLACEMENT PARTS OTHER THAN THOSE SUPPLIED BY LANG OR THEIR AUTHORIZED DISTRIBUTORS CAN CAUSE BODILY INJURY TO THE OPERATOR AND DAMAGE TO THE EQUIPMENT AND WILL VOID ALL WARRANTIES.



# EQUIPMENT DESCRIPTION

## Lang Model: Lang Model: ECCO-PT

### Exterior Construction

The oven exterior dimensions are 40" (100 cm) Wide, 27" (67.5 cm) High, 38" (95 cm) Deep. The Top, Front, Back, and Sides are constructed of stainless steel with an aluminized bottom.

The oven doors come standard with double pane windows.

The door handle is constructed of Stainless Steel and Phonolic Tubing.

The oven cavity is insulated with high temperature insulation for efficiency and reduced heat loss.

### Interior Construction

The oven cavity dimensions are 29" (72.5 cm) Wide, 20" (50.84 cm) High, 21" (53.38 cm) Deep.

The interior of the oven is constructed of porcelainized stainless steel.

### Operation

The ECCO-PT oven is a forced air convection oven with a vented oven cavity.

The air is driven by a 1/3 HP fan motor.

### Controls

Icon driven (touch) panel allows for easy operation.

Complete computerized controls.

Pre-Programmable product selections.

Independent shelf timers for each shelf.

Load control through use of Cooking Curves.

Shelf compensation for uniform baking.

Solid state temperature sensing and controls.

Dual speed fan.

Manual override controls.

### Technical

The ECCO-PT oven operates on either 208/240V or 480V. **This must be specified when ordering.**

Floor space required is 48" (122.6 cm) wide, 44" (112.5 cm) deep.

The oven weighs 430 lbs.

## Receiving the Oven

Upon receipt, check for freight damage, both visible and concealed. Visible damage should be noted on the freight bill at the time of delivery and signed by the carrier's agent. Concealed loss or damage means loss or damage, which does not become apparent until the merchandise has been unpacked. If concealed loss or damage is discovered upon unpacking, make a written request for inspection by the carrier's agent within 15 days of delivery. All packing material should be kept for inspection. **Do not return damaged merchandise to Lang Manufacturing Company. File your claim with the carrier.**

## Location

Prior to un-crating, move the oven as near to its intended location as practical. The crating will help protect the unit from the physical damage normally associated with moving it through hallways and doorways.

## Un-crating

The oven will arrive completely assembled inside a wood frame and strapped to a skid. **Cut the straps and remove the wood frame.**

**CAUTION: THE OVEN WEIGHS 430 LBS. FOR SAFE HANDLING, INSTALLER SHOULD OBTAIN HELP AS NEEDED, OR EMPLOY APPROPRIATE MATERIALS HANDLING EQUIPMENT (SUCH AS A FORKLIFT, DOLLY, OR PALLET JACK) TO REMOVE THE UNIT FROM THE SKID AND MOVE IT TO THE PLACE OF INSTALLATION.**



**CAUTION: ANY STAND, COUNTER OR OTHER DEVICE ON WHICH THE OVEN WILL BE LOCATED MUST BE DESIGNED TO SUPPORT THE WEIGHT OF THE OVEN.**



**CAUTION: SHIPPING STRAPS ARE UNDER TENSION AND CAN SNAP BACK WHEN CUT.**



Remove Oven from skid and place in intended location.

# INSTALLATION

**DANGER:** THIS APPLIANCE MUST BE GROUNDED AT THE TERMINAL PROVIDED. FAILURE TO GROUND THE APPLIANCE COULD RESULT IN ELECTROCUTION AND DEATH.

**WARNING:** INSTALLATION OF THE UNIT MUST BE DONE BY PERSONNEL QUALIFIED TO WORK WITH ELECTRICITY AND PLUMBING. IMPROPER INSTALLATION CAN CAUSE INJURY TO PERSONNEL AND/OR DAMAGE TO EQUIPMENT. UNIT MUST BE INSTALLED IN ACCORDANCE WITH ALL APPLICABLE CODES.

**NOTICE:** The data plate is located above control panel behind wire mesh screen. The oven voltage, wattage, serial number, wire size, and clearance specifications are on the data plate. This information should be carefully read and understood before proceeding with the installation.

**NOTICE:** The installation of any components such as a vent hood, grease extractors, fire extinguisher systems, must conform to their applicable National, State and locally recognized installation standards.



## Leg Installation

Legs are available for both the single and double deck installations. Single deck installations require a 27-inch leg. Double deck installations require 6-inch legs or casters.

To install the 27-inch legs, place some cardboard on the floor and gently tip the oven onto its back. Fasten two legs to the oven's front corners using the four 5/16 inch bolts provided in the leg kit. Lift the oven onto its front legs and block the back up using one of the 27-inch legs set upside down in the center rear of the oven body. Install the last 27-inch leg onto the oven body on the control side rear. Gently lift the oven rear, remove the leg set to support the oven center and install it on the last rear corner.

To install the 6-inch legs or casters, follow the instructions in the Leg Pad section on the following pages or in the Leg Pad box supplied with the oven.

The adjustable feet on the bottom of each leg may be screwed in or out as necessary to level the oven.

A torpedo level placed on an oven rack will assist in leveling the oven.

## Stacking the Ovens

Remove all the plug buttons from the top of the lower oven.

Remove the stacking kit from the oven compartment of one oven and install the 1 1/4-inch plastic bushing into the top of the lower oven.

Tip the top oven backwards and install two 3/8-inch socket head bolts, found in the stacking kit, into the two front leg holes that match the holes in the top of the lower oven. Install the socket head bolts with the heads of the bolt pointing away from the oven.

Lift the top oven and gently set on top of the lower oven so that the heads of the socket head bolts nest into the holes in the top of the lower oven.



## INSTALLATION CONT'D

### **Leg Pad Adapter**

Identify the front and rear leg adapters (the front adapters have two threaded inserts, the rear has four).

#### **Leg to Adapter Installation:**

Install the leg's threaded stud through the hole in the adapter labeled "C" with the bent flange of the adapter facing away from the leg.

Screw the 3/4-inch nut supplied in the adapter kit onto the leg stud and tighten.

#### **Caster to Adapter Installation:**

Place the swivel caster against the front leg adapter with the flange of the adapter facing away from the caster.

Install the four 5/16 inch bolts through the caster base and the adapter holes labeled "A" then install the 5/16 inch nuts with washer and lock washers.

Place the rigid casters against the rear leg adapter with the flange of the adapter facing away from the caster.

Align the caster to the holes in the adapter labeled "B". NOTE: There are two sets of "B" holes set at 90° from the each other. One set will create a left rear adapter and the other set will create a right rear adapter.

Install four 5/16-inch bolts through the caster base and the adapter holes labeled "B" then install 5/16-inch nuts with lock washers and flat washers.

#### **Adapter to Oven Installation:**

Gently tip the oven onto its back. Place the front leg adapter into the front corners of the oven. The holes without the threaded inserts face the front of the oven and the flange on the adapter points toward the bottom of the oven.

The edge of the leg adapter with the threaded insert slips under the flange on the oven side, while the edge without the inserts sits on top of the threaded angle on the oven front.

Install two 3/8-inch bolts with lock washers and flat washers through the front holes "D" in the leg adapter and into the threaded inserts on the oven.

Thread one 3/8-inch bolt with lock washer and flat washer into the rear threaded hole labeled "E" on each of the leg adapters.

The forward threaded hole on the front leg adapter does not get a bolt installed.

Place the rear leg adapters into the rear corners of the oven so that the adapter is under the flange of the oven side and back. NOTE: If installing a caster place the adapter on the oven so that the casters roll forward.

Install for 3/8-inch bolts with lock washers and flat washers through the holes labeled "E" in the flange of the oven and into the threaded inserts of the leg adapter.

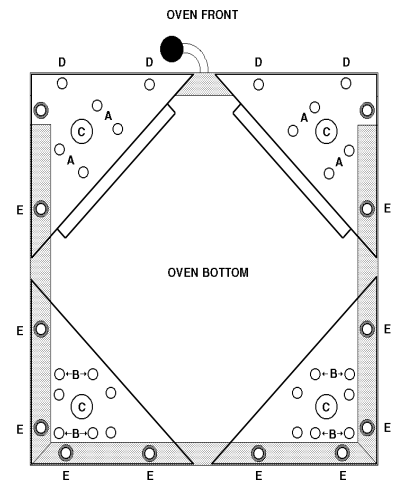

## Ventilation and Clearances

Standard minimum clearance from combustible construction is as follows.

- 4" from side
- 4" from back
- 6" from floor

These ovens may be set directly, without legs, on a curbed base or **non-combustible** floor.

If the oven is set without legs on a **non-combustible** floor or a curbed base, maintain a 4-inch back clearance.

If the oven is set directly against a **non-combustible** back wall, maintain a 6-inch clearance to the floor.

**Do not** install the oven closer than 4 inches from another oven on the right hand side (control panel side).

**Do not** install the oven closer than 12 inches from an uncontrolled heat source (char broiler etc.) on the right side.

Keep the appliance area free and clear of combustible material and do not obstruct the flow of combustion or ventilation air.

The installation of any components such as a vent hood, grease extractors, and/or fire extinguisher systems, must conform to the there applicable nationally recognized installation standards.

## Electrical Connection

The electrical service entrance is provided by a 1 1/4-inch knockout in the bottom right front corner of each oven, or at the oven back directly behind the control compartment. Grounding lugs are provided at both the front and rear service entrances.

The 208/240-volt oven is a dual voltage oven and is shipped from the factory as 208-volt. The oven must be field converted to operate on a 240-volt power supply.

To convert the oven to 240-volt, remove the panel above the power supply knock out at the back of the oven and toggle the switch to the 240-volt position.

With 480-volt installations check to be sure that the motor rotates in a clockwise direction as viewed from the front of the oven.

To reverse the motor rotation, switch any two incoming power supply leads and recheck the rotation.

Supply wire size must be large enough to carry the amperage load for the number of ovens being installed. Wire size information can be found on the oven DATA PLATE.

This oven can be installed on both single and three-phase supplies and is shipped from the factory for three-phase.

To phase the oven to match the power supply, follow the charts on the Wiring Diagram located at the back of the Manual.

# INITIAL START UP

## **Pre-Power On**

After the oven is installed and connected to power, prior to turning on, verify the following:

- The doors open and close freely.
- All racks are in the oven correctly.
- All packing materials have been removed from the inside of the oven.

## **Power On**

Once oven has been turned on verify that the blower wheel is spinning freely in a clockwise position and that the elements are heating properly.

**NOTICE:**      **During the first few hours of operation you may notice a small amount of smoke coming off the oven, and a faint odor from the smoke. This is normal for a new oven and will disappear after the first few hours of use.**

# OPERATION

## Control Panel

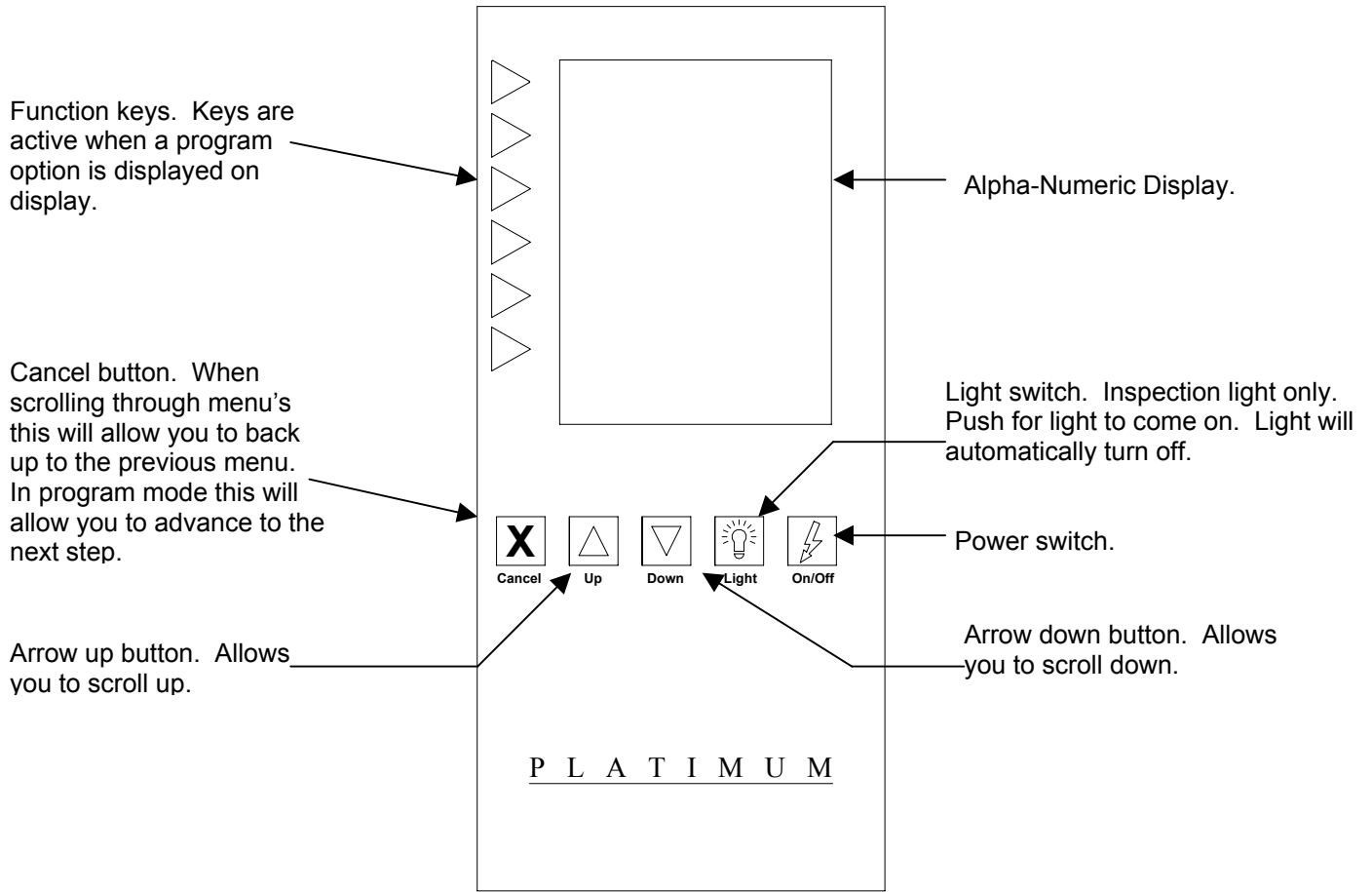

## OPERATION CONT'D

### Typical Operation Sequence

| ACTION                                      | RESULT   |
|---|--|
| Press the on switch.                        | Control panel comes on, display says " <b>LANG, Run Oven, Time Date Program.</b> " |
| Select " <b>Run Oven</b> ".                 | Display will show a list of product to choose.                                     |
| Select Product button next to Icon desired. | Display says " <b>Preheating to XXXF</b> ".  |
| <i>Beeper sounds briefly.</i>               | Display says " <b>Ready</b> ".   |
| Select Product to start.                    | Display shows possible product selection for that temperature.                     |
| Select Product to start.                    | Display says " <b>Select shelf</b> ".  |
| Press Product button next to desired shelf. | Display will show icon chosen and begin to count down.                             |
| <i>Beeper sounds continuously.</i>          | Display shows " <b>DONE</b> " press button and remove product from that shelf.     |
| Oven is ready for another product.          |  |

### **Hints & Suggestions**

Convection ovens constantly circulate air over and around the product. This strips away the thin layer of moisture and cool air from around the product allowing heat to penetrate more quickly.

Cooking times can be shortened and cooking temperatures can be reduced.

To convert standard deck oven recipes, reduce the temperature 50 degrees and the time by 25%. Make minor adjustments as necessary.

The lower the oven temperature the more even the bake.

Always weigh your product. This will give you a more consistent size, color and quality.

Check the product near the end of the initial cooking cycle by turning on the oven light and looking through the oven door windows.

Do not open the oven doors during baking as this will change the baking characteristics of the oven and make it difficult to determine a final program.

If the product is overdone on the outside and underdone on the inside, reduce the baking temperature.

If the product is pulling away from the edge of the pan, the temperature is too high or the cooking time too long.

The convection is a mechanical piece of equipment. The same control settings will always give the same results. If the results vary, problems may be because of product preparation.

## OPERATION CONT'D

### Loading

When loading and unloading the oven, stage products and racks so the oven doors are opened for the least amount of time.

Be sure that racks are level within the oven.

Bent or warped pans can greatly affect the evenness of the cook or bake.

If using baker's parchment, be sure the parchment does not blow over the product. The will create a uneven bake.

Load each shelf evenly. Spaces should be maintained equally between the pan and oven walls, front and back.

Do not overload pan's this will create a uneven bake.

For best baking results, load the oven from the center out during random loading.

**CAUTION: ALWAYS KEEP THE AREA NEAR THE APPLIANCE FREE FROM COMBUSTIBLE MATERIALS.**

**CAUTION: KEEP FLOOR IN FRONT OF EQUIPMENT CLEAN AND DRY. IF SPILLS OCCUR, CLEAN IMMEDIATELY, TO AVOID THE DANGER OF SLIPS OR FALLS.**



## MAINTENANCE & CLEANING

**WARNING:** KEEP WATER AND SOLUTIONS OUT OF CONTROLS.  
NEVER SPRAY OR HOSE CONTROL CONSOLE.

**CAUTION:** MOST CLEANERS ARE HARMFUL TO THE SKIN,  
EYES, MUCOUS MEMBRANES AND CLOTHING.  
PRECAUTIONS SHOULD BE TAKEN TO WEAR  
RUBBER GLOVES, GOGGLES OR FACE SHIELD AND  
PROTECTIVE CLOTHING. CAREFULLY READ THE  
WARNING AND FOLLOW THE DIRECTIONS ON THE  
LABEL OF THE CLEANER TO BE USED.

**NOTICE:** Never leave a chlorine sanitizer in contact with  
stainless steel surfaces longer than 10 minutes.  
Longer contact can cause corrosion.



### Cleaning

- Always start with a cold oven.
- The stainless exterior can easily be cleaned using Lang Mfg. Prime Shine (72804-41) oven cleaner.
- Always follow the cleaner manufacturer's instructions when using any cleaner.
- Care should be taken to prevent caustic cleaning compounds from coming in contact with the blower wheel.
- The oven racks, rack slides, and interior may be cleaned using Lang Mfg. Foam Deluxe (72804-36) oven cleaner.
- Discoloration or heat tint may be removed using Lang Mfg. Carbon Release (72804-32) oven cleaner.
- Always apply these cleaners when the oven is cold and rub in the direction of the metal's grain.



# TROUBLESHOOTING

## Symptoms

What follows is a chart of Symptoms and Possible Causes to aid in diagnosing faults with the oven.

Refer to the Symptoms column to locate the type of failure then to the Possible Cause for the items to be checked.

To test for a possible causes refer to the TEST section and locate the Possible Cause then refer to test to identify test procedures.

| <b>SYMPTOM</b>           | <b>POSSIBLE CAUSE</b>  |
|--------------------------|--|
| Display will not come on | <ul style="list-style-type: none"> <li>• No power to cord outlet</li> <li>• Oven unplugged from outlet</li> <li>• Failed power cord or plug</li> <li>• Contrast needs to be adjusted</li> <li>• Failed display board</li> </ul>  |
| Oven will not heat       | <ul style="list-style-type: none"> <li>• Power Switch is not “ON”</li> <li>• Product not selected</li> <li>• Failed Transformer</li> <li>• Failed Probe</li> <li>• Failed Circuit board</li> <li>• Failed Contactor</li> <li>• Failed Over-temperature Thermostat</li> <li>• Failed Element</li> </ul> |
| Oven motor will not run  | <ul style="list-style-type: none"> <li>• Power Switch is not “ON”</li> <li>• Product not selected</li> <li>• Failed Transformer</li> <li>• Failed Contactor</li> <li>• Failed Motor</li> <li>• Failed output on circuit board.</li> </ul>  |
| Product burning          | <ul style="list-style-type: none"> <li>• Product is cooked too long</li> <li>• Failed Probe</li> <li>• Failed Circuit board</li> </ul>   |
| Product under done       | <ul style="list-style-type: none"> <li>• Product is not cooking long enough</li> <li>• Failed Probe</li> <li>• Failed Circuit board</li> </ul>   |

# TROUBLESHOOTING CONT'D

## TESTS

### NOTICE:

Service on this, or any other, LANG appliance must be performed by qualified personnel only. Consult your authorized service station directory or call the factory at 1-800-224-LANG (5264), or WWW.LANGWORLD.COM For the service station nearest you.



### WARNING:

**BOTH HIGH AND LOW VOLTAGES ARE PRESENT INSIDE THIS APPLIANCE WHEN THE UNIT IS PLUGGED/WIRED INTO A LIVE RECEPTACLE. BEFORE REPLACING ANY PARTS, DISCONNECT THE UNIT FROM THE ELECTRIC POWER SUPPLY.**



If an item on the list is followed by an asterisk (\*), the work should be done by a factory authorized service representative.

| Possible Cause                           | TEST   |
|--|--|
| Product is cooked too long               | <ul style="list-style-type: none"> <li>• No test available, operational condition</li> </ul>   |
| Failed Probe                             | <ul style="list-style-type: none"> <li>• Check probe for proper resistance*</li> </ul>   |
| Failed Circuit board                     | <ul style="list-style-type: none"> <li>• Confirm that Circuit board is getting correct voltage and putting out correct voltage*</li> </ul>   |
| Failed Transformer                       | <ul style="list-style-type: none"> <li>• Check both Primary and Secondary coils for correct voltage*</li> </ul>  |
| Failed Contactor                         | <ul style="list-style-type: none"> <li>• Remove the wires from the contactor coil and check for continuity across the contactor coil connection*</li> <li>• Ensure the contactor moveable points move freely up and down*</li> </ul> |
| Failed Motor                             | <ul style="list-style-type: none"> <li>• Confirm that motor is getting correct voltage*</li> </ul>   |
| Failed or disconnected safety thermostat | <ul style="list-style-type: none"> <li>• Check across the thermostat connectors for continuity*</li> </ul>   |
| Failed Element                           | <ul style="list-style-type: none"> <li>• Confirm that Elements are getting correct voltage and have continuity*</li> </ul>   |

### CAUTION:

**USE OF ANY REPLACEMENT PARTS OTHER THAN THOSE SUPPLIED BY LANG OR THEIR AUTHORIZED DISTRIBUTORS CAN CAUSE BODILY INJURY TO THE OPERATOR AND DAMAGE TO THE EQUIPMENT AND WILL VOID ALL WARRANTIES.**



## PARTS LIST

| DESCRIPTION                                      | PART NO.  |
|--|-----------|
| Element ECCO Oven 208/240 Volt 11000 Watts       | 11090-16  |
| Element ECCO Oven 480 Volt 11000 Watts           | 11090-18  |
| Motor 1/3 HP 480 Volt 2 Speed                    | 30200-16  |
| Motor 1/3 HP 208/240 Volt 2 Speed                | 30200-17  |
| Switch Micro Convection Oven Door                | 30301-02  |
| Switch Toggle Spring Return                      | 30303-16  |
| Thermostat Safety 490°F Open                     | 30401-09  |
| Thermostat 450°F Oven                            | 30402-27  |
| Terminal Block 24 Position Quick Disconnect      | 30503-01  |
| Relay 240 VAC                                    | 30600-02  |
| Contactors 3 Pole 24 VAC                         | 30700-06  |
| Contactors 2 Pole 24 VAC (208/240 VAC only)      | 30701-05  |
| Contactors 2 Speed Motor 24 VAC (480 VAC only)   | 30705-03  |
| Fuse 15 AMP 300 Volt                             | 30900-10  |
| Fuse Holder 15 Amp                               | 30901-08  |
| Cable Ribbon Assembly                            | 31110-13  |
| Transformer 480/24 VAC                           | 31400-15  |
| Transformer 240/12 VAC                           | 31400-26  |
| Lamp Socket                                      | 31602-04  |
| Lamp Incandescent 250 Volt Clear                 | 31603-04  |
| Oven Lamp Lens (Watch Glass)                     | 31604-01  |
| Oven Lamp Lens Gasket                            | 31604-02  |
| Circuit Breaker 208/240 Volt 1-Pole              | 31800-01  |
| Circuit Breaker 480 Volt 3-Pole                  | 31800-04  |
| Circuit Board Display                            | 40102-25  |
| Circuit Board Microprocessor                     | 40102-26  |
| Probe Temperature Sensor                         | 41100-08  |
| Oven Rack  | 50200-20  |
| Oven Rack Slide                                  | 50200-36  |
| Turnbuckle Assembly                              | 50312-02  |
| Door Left Hand                                   | 51100-45  |
| Door Right Hand                                  | 51100-46  |
| Panel Label, Platinum                            | 60101-882 |
| Valve Manual Main Water Supply (Steam Units)     | 70400-02  |
| Valve Manual Water Supply (Steam Units)          | 70402-08  |
| Valve Solenoid 24/60V Water Supply (Steam Units) | 70403-01  |
| Regulator Water Supply (Steam Units)             | 70404-01  |
| Handle Assembly, Single Handle Oven              | 70603-15  |
| Knob Thermostat 450°F Oven                       | 70701-28  |
| Knob Damper Black                                | 70701-25  |
| Window Assembly, Oven Door                       | 71301-04  |
| Blower Wheel                                     | 71500-05  |
| Blower Wheel (Steam Units)                       | 51100-57  |
| Orifice Water/Steam #60 DRL (Steam Units)        | 80405-01  |

# WIRING DIAGRAM 208/240

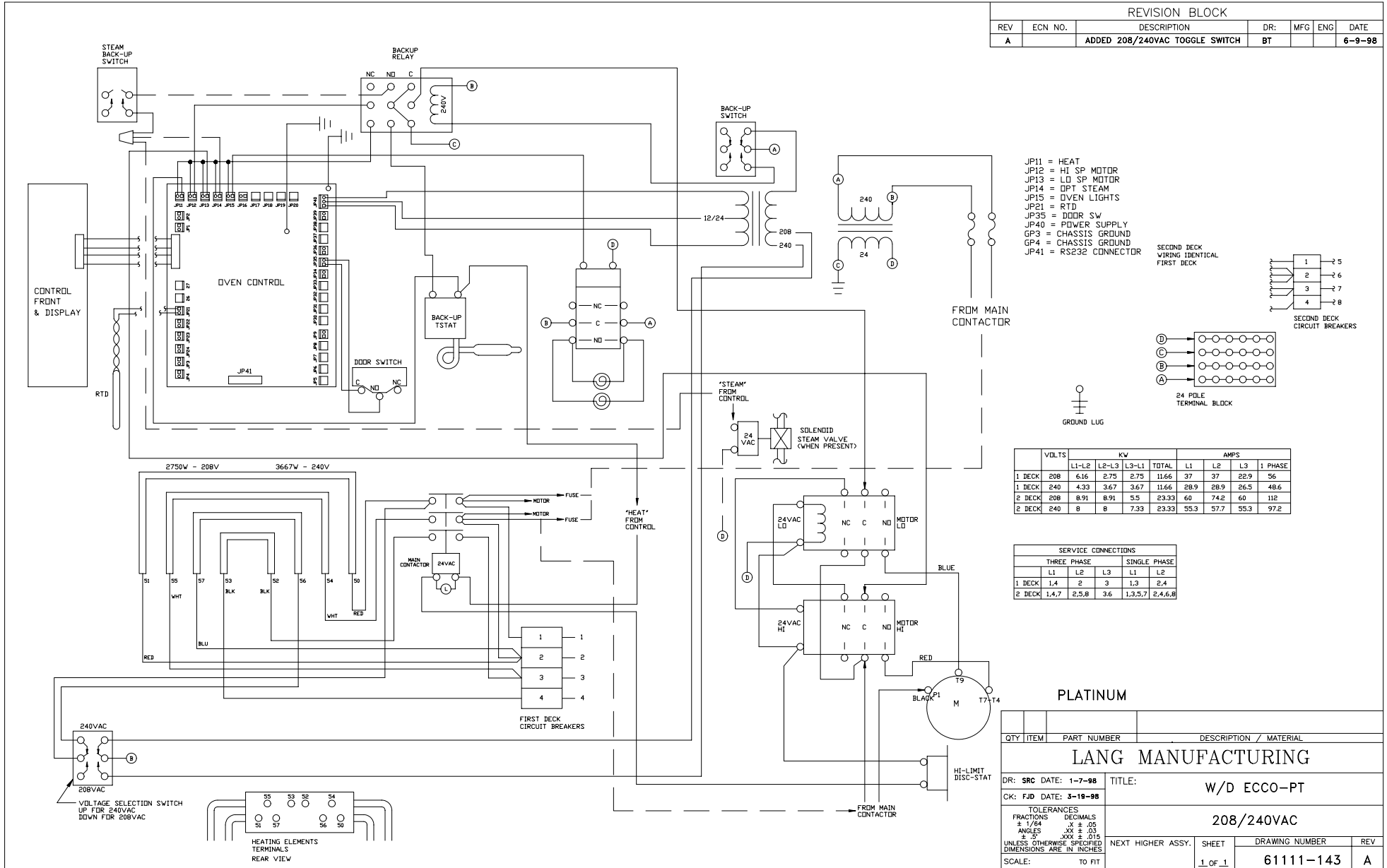

# WIRING DIAGRAM 480

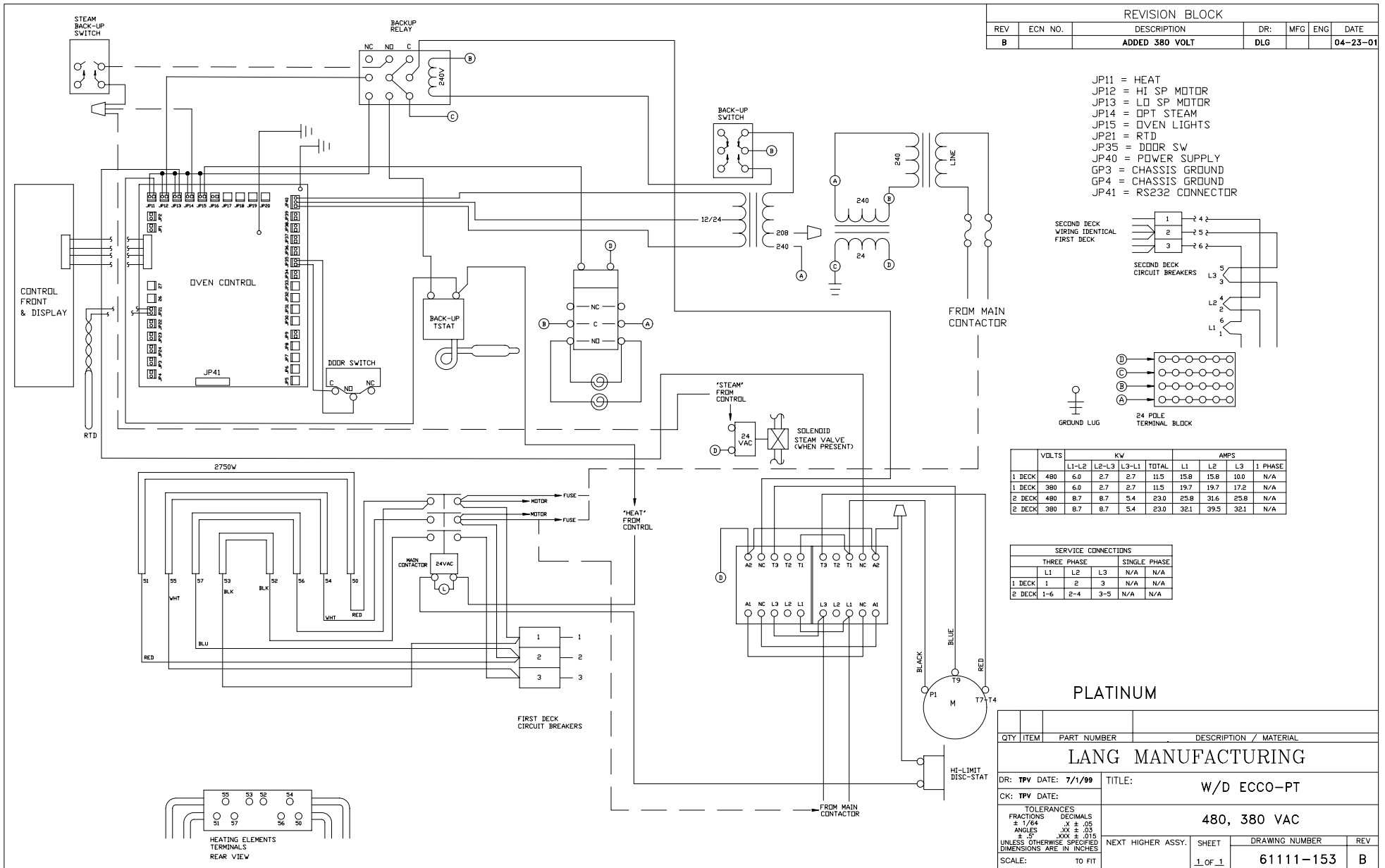

# WIRING DIAGRAM 220/380 & 240/415

