

# **Lang**<sup>®</sup>

## **ELECTRIC HALF SIZE COMPUTERIZED CONVECTION OVEN ECO-H-PP**

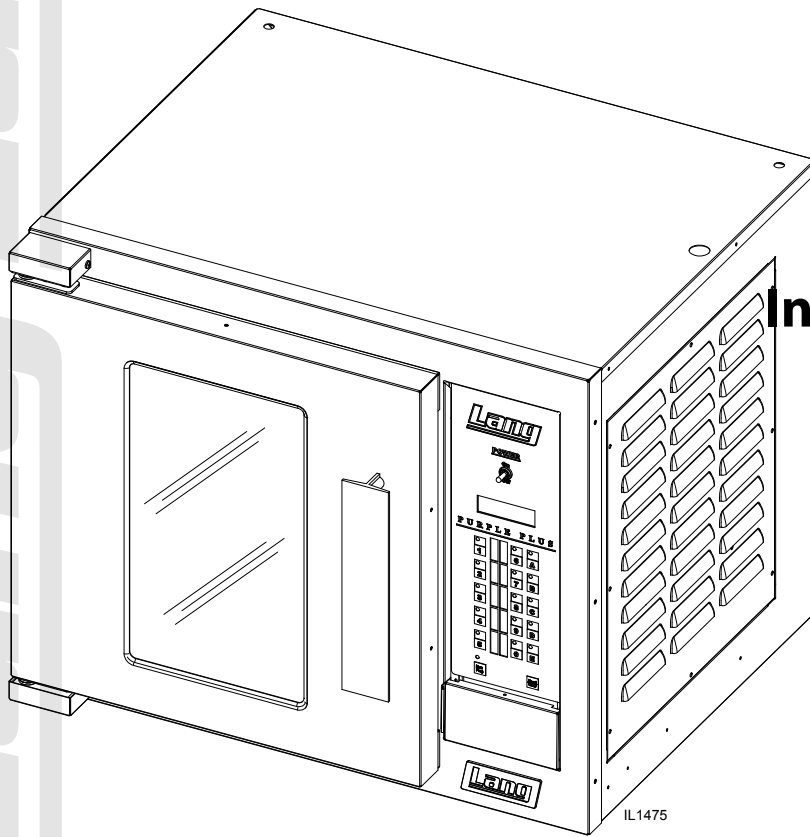

### **Installation and Operation Instructions**

2M-W494 Rev. E 3/24/15

ECO-H-PP

## SAFETY SYMBOL



These symbols are intended to alert the user to the presence of important operating and maintenance instructions in the manual accompanying the appliance.

### **FOR YOUR SAFETY**

**DO NOT STORE OR USE GASOLINE OR OTHER FLAMMABLE VAPORS AND LIQUIDS IN THE VICINTIY OF THIS OR ANY OTHER APPLIANCE.**

### **POST IN PROMINENT LOCATION**

**INSTRUCTIONS TO BE FOLLOWED IN THE EVENT USER SMELLS GAS. THIS INFORMATION SHALL BE OBTAINED BY CONSULTING YOUR LOCAL GAS SUPPLIER. AS A MINIMUM, TURN OFF THE GAS AND CALL YOUR GAS COMPANY AND YOUR AUTHORIZED SERVICE AGENT. EVACUATE ALL PERSONNEL FROM THE AREA.**

### **WARNING**

**IMPROPER INSTALLATION, ADJUSTMENT, ALTERATION, SERVICE OR MAINTENANCE CAN CAUSE PROPERTY DAMAGE, INJURY OR DEATH. READ THE INSTALLATION, OPERATION & MAINTENANCE INSTRUCTIONS THOROUGHLY BEFORE INSTALLING OR SERVICING THIS EQUIPMENT.**



**WARNING**  
**RISK OF FIRE OR ELECTRIC SHOCK**  
**DO NOT OPEN**



**WARNING, TO REDUCE THE RISK OF ELECTRICAL SHOCK, DO NOT REMOVE CONTROL PANEL. NO USER-SERVICABLE PARTS INSIDE. REPAIRS SHOULD BE DONE BY AUTHORIZED SERVICE PERSONNEL ONLY.**

### **NOTICE**

Using any part other than genuine Lang factory supplied parts relieves the manufacturer of all liability.

Lang reserves the right to change specifications and product design without notice. Such revisions do not entitle the buyer to corresponding changes, improvements, additions or replacements for previously purchased equipment.

Due to periodic changes in designs, methods, procedures, policies and regulations, the specifications contained in this sheet are subject to change without notice. While Lang exercises good faith efforts to provide information that is accurate, we are not responsible for errors or omissions in information provided or conclusions reached as a result of using the specifications. By using the information provided, the user assumes all risks in connection with such use.

## **MAINTENANCE AND REPAIRS**

Contact your local dealer for service or required maintenance. Please record the model number, serial number, voltage and purchase & Installation Information in the area below and have it ready when you call to ensure a faster service.

Model No.: \_\_\_\_\_

Purchased From: \_\_\_\_\_

Serial No.: \_\_\_\_\_

Location: \_\_\_\_\_

Voltage: \_\_\_\_\_

Purchase Date: \_\_\_\_\_

1-Phase or 3 Phase: \_\_\_\_\_

Installed Date: \_\_\_\_\_



## PROBLEMS, QUESTIONS or CONCERNS

Before you proceed consult you authorized Lang service agent directory  
or  
Call the Lang Technical Service & Parts Department at 314-678-6315.

### TABLE OF CONTENTS

Specifications . . . . .	4
Equipment Description . . . . .	5
Unpacking . . . . .	6
Installation	
Leg Installation . . . . .	7
Stacking the Oven. . . . .	7
Ventilation & Clearance . . . . .	8
Electrical Connection . . . . .	8
Oven Voltage . . . . .	8
Reversing the door . . . . .	9
Initial Start-Up	
Pre-Power On . . . . .	10
Power On . . . . .	10
General Operation & Programming	
Control Panel . . . . .	11
Loading . . . . .	12
Daily Operation . . . . .	13
Program Menu Record Table . . . . .	14
Programming Procedures . . . . .	15-16
Maintenance / Cleaning . . . . .	17
Troubleshooting	
Symptoms & Possible Causes . . . . .	18
Wiring Diagram	
ECOHP-PP 208-240V WD61111-147. . . . .	19
ECOHP-PP 220-380V, 240V-415V w 2SPD CE WD61111-170 . . . . .	20
ECOHP-PP 220-380V, 240-415V WD61111-151 . . . . .	21
ECOHP-PP 480V WD61111-168 . . . . .	22
Exploded View & Parts List . . . . .	24-34

#### NOTICE

**Service on this or any other Lang appliance must be performed by qualified personnel only. Consult your Lang Authorized Service Agent Directory. You can call our tech service number 314-678-6315 or visit our website [www.langworld.com](http://www.langworld.com) for the service agent nearest you.**

## SPECIFICATIONS

Model	Height x Width x Depth (without optional stand)	Clearance from combustible surface	Weight		Freight Class
			Installed	Shipping	
ECOH	25.3" x 30.2" x 25.3" 642mm x 766mm x 643mm	Side: 6", Back: 6", Floor: 6"	185 lbs. (84 kg)	225lbs (102 kg)	85

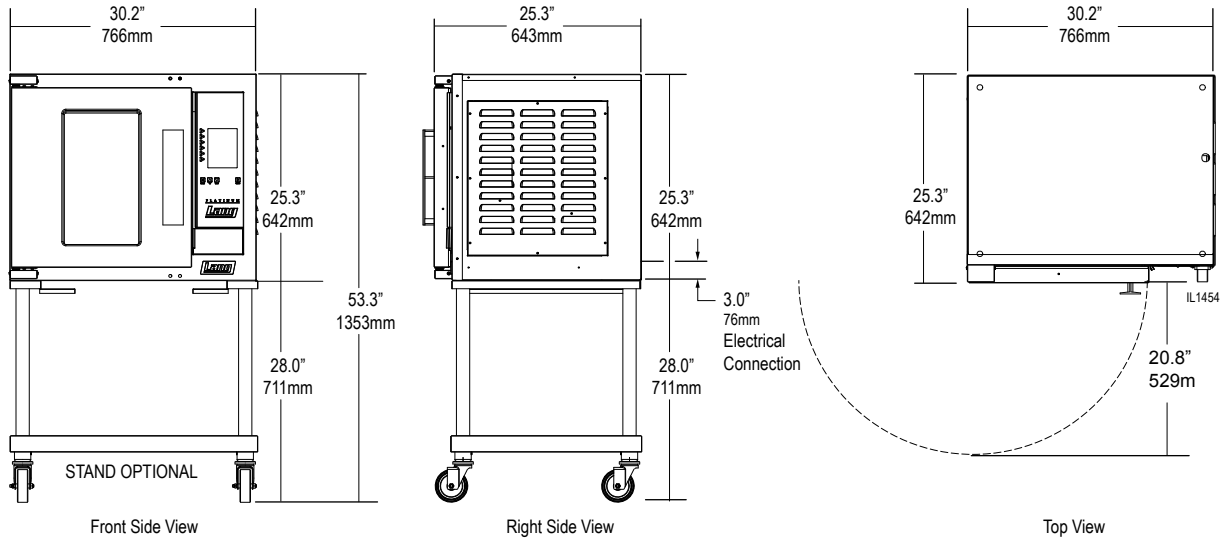

### Electrical Specifications

Model No	VOLTS AC	Hz.	MOTOR AMPS	PHASE	AMPS 3PH/ NTRAL	KW TOT.	AMPS 1 PH	WIRE 1 PH	L1	L2	L3	WIRE 3 PH
ECOH-PP2/4BK	240/415	50/60	3.3	3PH	11	7.8			11	10.5	10.5	12
ECOH-PP208BK	208	60	3.3	1/3		7.8	38	8	23	21	23	10
ECOH-PP208BR	208	60	3.3	1/3		7.8	38	8	23	21	23	10
ECOH-PP-208V	208	60	3.3	1/3		7.8	38	8	23	21	23	10
ECOH-PP-240V	240	60	2.6	1/3		7.8	33	8	20	18	20	12
ECOH-PP208WB	208	60	3.3	1/3		7.8	38	8	23	21	23	10
ECOH-PP240BK	240	60	2.6	1/3		7.8	33	8	20	18	20	12
ECOH-PP240WB	240	60	2.6	1/3		7.8	33	8	20	18	20	12

## EQUIPMENT DESCRIPTION

### Exterior Construction

The Top, Front, Back, and Sides are constructed of stainless steel with an aluminized bottom.

The oven exterior dimensions are:

30" (76.2 cm) Wide,  
25.25" (74.3 cm) High,  
26.5" (67.31 cm) Deep.

The oven door comes standard with a high temperature insulated window equipped with a polycarbonate handle.

The oven cavity is insulated with high temperature insulation for efficiency and reduced heat loss.

### Interior Construction

The oven is designed for five shelves and comes with five Chrome Plated Racks.

The interior cooking chamber is constructed of stainless steel with dimensions of:

15" (38.1 cm) Wide,  
20" (50.84 cm) High,  
21" (53.38 cm) Deep.

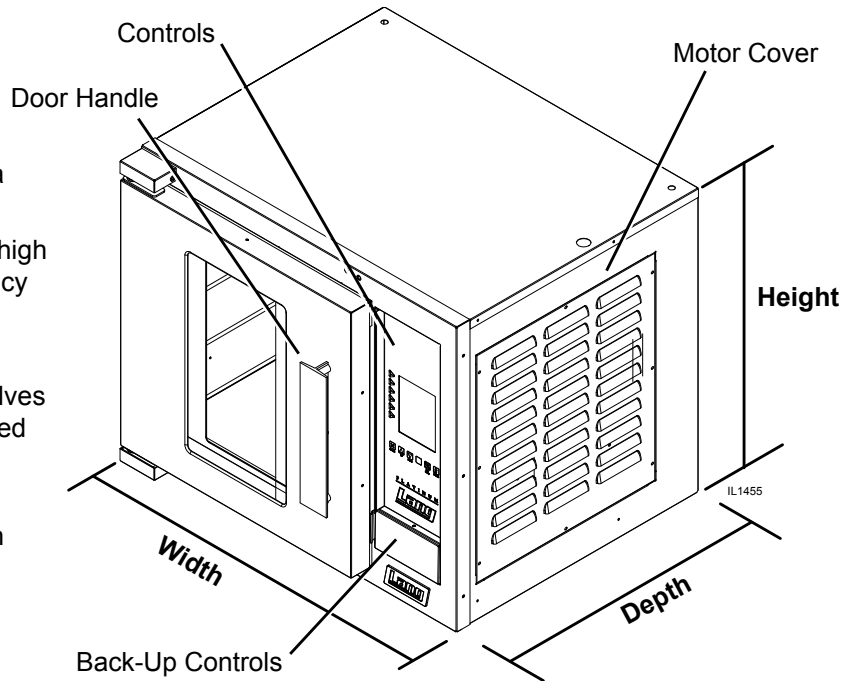

### Operation

The ECOH oven is a forced air convection oven with a vented oven cavity.

The air is driven by a 1/3 HP fan motor.

### Controls

Pre-Programmable Product Selections

Independent Shelf Timers for each Shelf.

Shelf Compensation Timing for uniform baking.

### Technical

Oven operates as shipped 208V, or 240V (single or three phase), or 480V (three phase).

The oven can be shipped with a Power Cord and Plug attached, but must be specified upon ordering (*part number is listed in the Parts portion of this manual*).

Floor space required is 42" (106.68cm) Wide, 32.5" (82.55cm) Deep.

The oven weighs approximately 225 lb. (102.5 Kilograms).

The ovens are stackable, stacking kit available upon request.

**NOTICE** The data plate is on the back side of the oven above the power cord. The oven voltage, wattage, serial number, wire size, and clearance specifications are on the data plate. This information should be carefully read and understood before proceeding with the installation.

## UNPACKING

### Receiving the Oven

Upon receipt, check for freight damage, both visible and concealed. Visible damage should be noted on the freight bill at the time of delivery and signed by the carrier's agent. Concealed loss or damage means it does not become apparent until the merchandise has been unpacked. If concealed loss or damage is discovered upon unpacking, make a written request for inspection by the carrier's agent within 15 days of delivery. All packing material should be kept for inspection. Do not return damaged merchandise to Star Manufacturing Company. File your claim with the carrier.

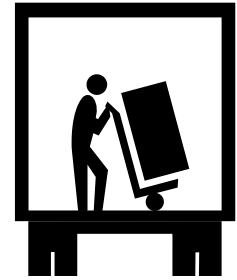

### Location

Prior to un-crating, move the oven as near to its intended location as practical. The crating will help protect the unit from the physical damage normally associated with moving it through hallways and doorways.

### Un-crating

The oven will arrive completely assembled inside a wood frame and strapped to a skid. Cut the straps and remove the wood frame.

The oven can now be removed from the skid.



**THE UNIT IS EXTREMELY HEAVY. FOR SAFE HANDLING, INSTALLER SHOULD OBTAIN HELP AS NEEDED, OR EMPLOY APPROPRIATE MATERIALS HANDLING EQUIPMENT (SUCH AS A FORKLIFT, DOLLY, OR PALLET JACK) TO REMOVE THE UNIT FROM THE SKID AND MOVE IT TO THE PLACE OF INSTALLATION.**

**ANY STAND, COUNTER OR OTHER DEVICE ON WHICH OVEN WILL BE LOCATED MUST BE DESIGNED TO SUPPORT THE WEIGHT OF THE OVEN.**

**SHIPPING STRAPS ARE UNDER TENSION AND CAN SNAP BACK WHEN CUT.**

# INSTALLATION

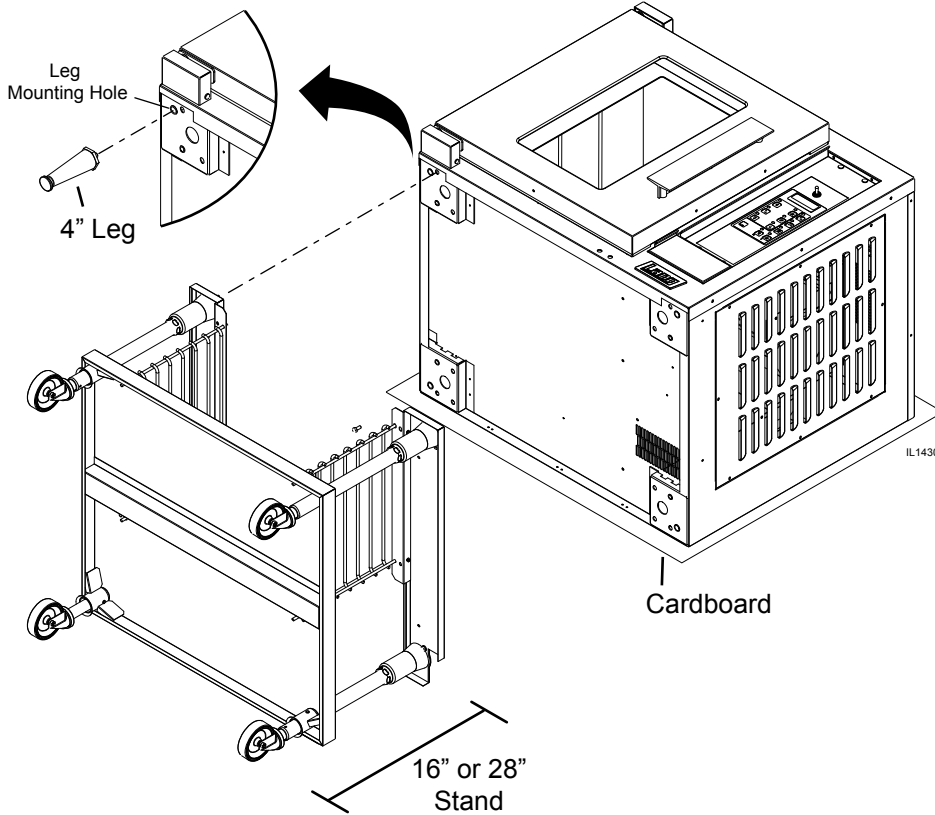

## Leg Installation

4" legs are available for single countertop installations. Single and double deck installations require 16" or 28" stand installation, casters may also be used in certain situations.

To install the 4" legs, place some cardboard on the floor and gently tip the unit onto its back. Fasten the four, 4" legs into the threaded holes located on the bottom of the unit. Gently lift the oven into its operating position.

16" & 28" stand installation, after following the assembly instructions that were provided with the stand, gently lower unit on to some cardboard as shown here. Align the stand with the bottom of the unit and secure with the hardware provided. With the assistance of carefully raise the unit to its vertical position.

## Stacking the Ovens

Two alignment pins (pn: 2C-20108-11) are needed if you intend on stacking two ECOH on each other as shown. These pins must be requested at the time of purchase, or call your Lang authorized service agent, or Lang parts department at 314-678-6315.

Having completed the previous step remove any and all button plugs from the lower unit, so the upper unit will lay properly.

Lay the upper unit on its back and screw the alignment pins into the two rear holes.

With assistance lift the upper unit onto the lower unit, being certain that the alignment pins go into the alignment holes, as shown here.

**NOTE: Each unit must have separate electrical connections**

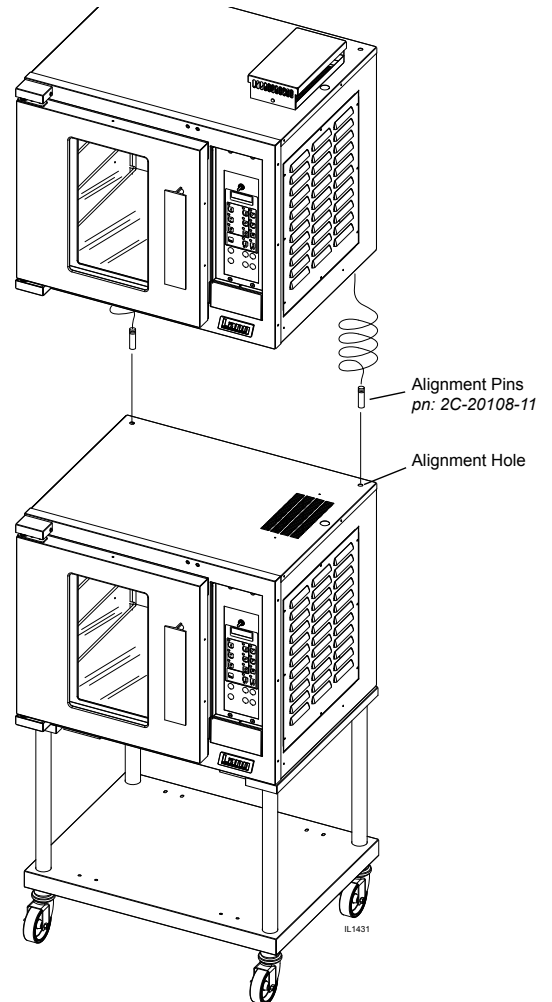

### Ventilation and Clearances

Standard minimum clearance from combustible construction is as follows.

4" from side

4" from back

6" from floor

- These ovens may be set directly, without legs, on a curbed base or non-combustible floor.
- If the oven is set without legs on a non-combustible floor or a curbed base, maintain a 4-inch back clearance.
- If the oven is set directly against a non-combustible back wall, maintain a 6-inch clearance to the floor.
- Do not install the oven closer than 12 inches from an uncontrolled heat source (char broiler etc.) on the right side.
- Keep the area free & clear of combustible material, and do not obstruct the flow of combustion or ventilation air.
- The installation of any components such as a vent hood, grease extractors, and/or fire extinguisher systems, must conform to the applicable nationally recognized installation standards.

**NOTICE**     **The installation of any components such as a vent hood, grease extractors, fire extinguisher systems, must conform to their applicable National, State and locally recognized installation standards.**

### Electrical Connection

The electrical connection must be made in accordance with local codes or in the absence of local codes with NFPA No. 70 latest edition (in Canada use: CSA STD. C22.1).

The electrical service entrance is provided by a 1 1/4-inch knockout at the oven back directly behind the control compartment. A grounding lug is provided at the rear service entrance.

Certain units are provided with or can be purchased with a Cord & Plug kit (*Part number 9Q-ECOH-CK*). This kit includes a 48" cord with a NEMA L15-30P plug and is for 3 Phase units ONLY. In stacked situations each units needs to have separate cord & plug assemblies.

### Oven Voltage

The Lang Model ECOH ovens can be operated on 208, 240-volt (single or three phase), or 240/415V, 480-volt (three phase only) source. The Amp draw, KW rating, and phasing can be found in specification section of this manual or on the nameplate attached to the unit..



**WARNING**

**THIS APPLIANCE MUST BE GROUNDED AT THE TERMINAL PROVIDED. FAILURE TO GROUND THE APPLIANCE COULD RESULT IN ELECTROCUTION AND DEATH.**



**WARNING**

**INSTALLATION OF THE UNIT MUST BE DONE BY PERSONNEL QUALIFIED TO WORK WITH ELECTRICITY AND PLUMBING. IMPROPER INSTALLATION CAN CAUSE INJURY TO PERSONNEL AND/OR DAMAGE TO EQUIPMENT. UNIT MUST BE INSTALLED IN ACCORDANCE WITH ALL APPLICABLE CODES.**



## Reversing the door

1. Disconnect oven from power.
2. Remove the top and bottom door hinge covers (4) by removing the two 10-32 Phillip head screws (8).
3. Remove the top door hinge bracket (1) from the oven by removing the two ¼-20 Phillip head screws (7). The hinge should now slide off of the door pin (this will now be your right hand lower hinge)
4. Lift the door off the bottom pin and set aside.
5. Remove the bottom door hinge bracket (2) by removing the two ¼-20 Phillip head screws (7) (this will now be your upper right hand hinge).
6. Remove the lower hinge mounting plate (9) by pulling it from behind the leg pad adapter on the bottom of the oven.
7. Remove the two Phillips head screws in the bottom right corner of the oven, where the new hinge will be placed.
8. Slide the hinge mounting plate (9) into place and mount the hinge bracket (this should be your old upper hinge) using two ¼-20 (7) Phillips head screws.
9. Remove the two Phillips head screws in the upper right corner of the oven where the new hinge will be placed.
10. Rotate the door 180° and slide the door pin into the bottom hinge bracket.
11. Slide the upper door hinge (1) onto the upper door pin and then screw into place using two ¼-20 Phillip head screws.
12. Place the top and bottom door hinge covers (4) back on the oven using two 10-32 Phillip head screws (8).

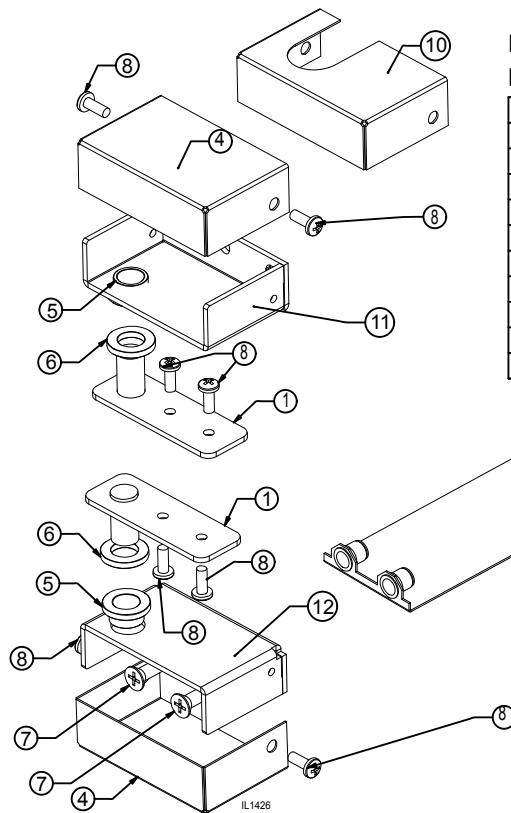

### ECOH HINGE RELPACEMENT KIT

pn: Q9-50313-030

ITEM NO.	QTY.	PART NO.	DESCRIPTION
3	2	50313-031	HINGE PIN WELDMENT
4	2	EH-267	EH HINGE COVER
5	2	70201-19	
6	2	70201-01	
7	2	20109-43	
8	8	20109-15	
9	1	eh-198-1	BOTTOM HINGE PLATE ASSY
10	1	CR30-148	UPPER HINGE COVER FOR EH
11	1	EH-265-1	EH HINGE - TOP - FOR SVC KIT
12	1	EH-266-1	EH HINGE - BOTTOM - FOR SVC KIT

INSERT BEARINGS (ITEMS "5") INTO THE HINGES (ITEMS "1" & "2") AS SHOWN THEN REAM WITH A .508 REAMER.

## INITIAL START UP

### Pre-Power On

After the oven is installed and connected to power, prior to turning on, verify the following

- The door opens and closes freely
- All racks are in the oven correctly
- All packing materials have been removed from the inside of the oven

### Power On

Once the oven has been turned on verify that the blower wheel is spinning freely in a clockwise position and that the elements are heating properly.

Switch the back-up controls on and make certain it can run the unit,

Confirm that the thermostat knob in the back-up controls is move freely.

### USB Connection

Units are now supplied with a USB connection, located with the the Back-Up Controls. This is for future programming needs of your unit and is not part of the units initial start-up or daily operation.

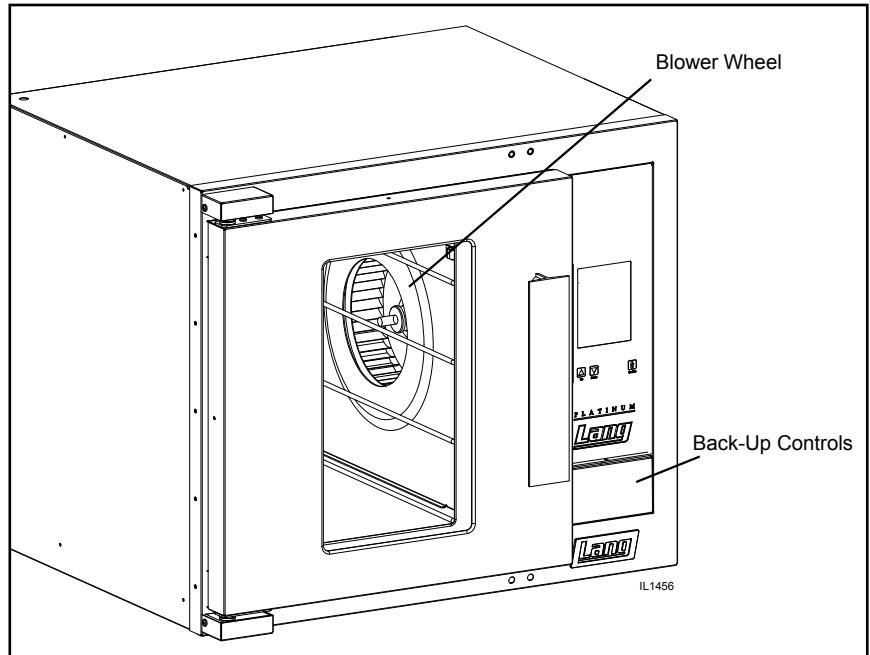

**NOTICE** During the first few hours of operation you may notice a small amount of smoke coming from the oven, and a faint odor from the smoke. This is normal for a new unit and will disappear after the first few hours of use.

## General Operation & Programming cont.

### ECOH-PP Control Panel

The control panel consists of the following items. Detailed operational descriptions are given later this section.

**Power Switch:** Turns the oven on and off

**Alpha Numeric Display:** Displays your interface with the computer.

**Product Select Button:** Each button can be programmed for a specific menu, see programming section to see how.

**Shelf Select Button:** Press to select which shelf the product will be placed on. "A" is the top position, "E" is the bottom position.

**Manual Program Button:** Used when product being cooked is for one time only.

**Read / Clear Button:** Used to read programs, clear programs, and to access program menus.

### Typical Operation Sequence

Action	Result
Turn power switch to <b>ON</b> .	Control panel comes on; display says " <b>SELECT PRODUCT</b> or <b>READ/CLEAR TO PROGRAM</b> ."
Press a product button.	Display says " <b>PRODUCT X PREHEATING TO XXX F</b> ". Motor starts and oven begins preheating to the programmed temperature.
Beeper sounds briefly.	Display says " <b>READY SELECT PRODUCT TO START</b> ".
Open the oven doors and load the product. Close the door and press the product button again.	Beeper sounds briefly and display says, " <b>SELECT OVEN SHELVES PRODUCT X</b> ".
Press the shelf button(s) which correspond to the shelf positions, which the product is loaded (A equals the top shelf and E equals the bottom shelf).	Display shows a countdown timer and begins to count toward zero.
Beeper sounds continuously.	Display shows " <b>DONE PRESS SHELF BUTTON X, REMOVE PRODUCT</b> ", shelf button(s) flash.
Press the flashing shelf button(s).	Beeper stops. Display shows " <b>READY SELECT PRODUCT TO START</b> " if no other shelves carry product or resume count down for shelves that still have product cooking.
Open oven door and remove the product, which corresponds to flashing shelf button(s).	

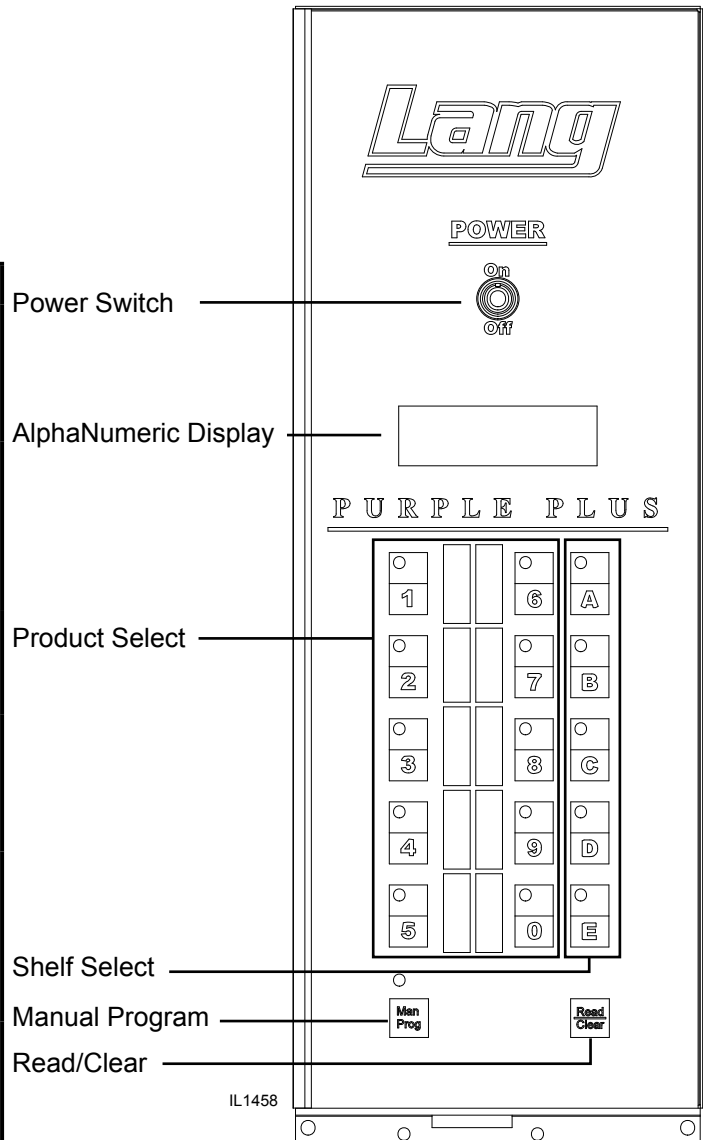

PURPLE PLUS

### Loading

Here are some things to remember when loading your oven.

- When loading and unloading the oven, stage products and racks so the oven door is opened for the least amount of time.
- Be sure that racks are level within the oven.
- Bent or warped pans can greatly affect the evenness of the cook or bake.
- If using baker's parchment, be sure the parchment does not blow over the product. That will create an uneven bake.
- Load each shelf evenly. Spaces should be maintained equally between the pan and oven walls, front and back.
- Do not overload pan's this will create an uneven bake.
- For best baking results, load the oven from the center out during random loading.



**CAUTION**

**ALWAYS KEEP THE AREA NEAR THE APPLIANCE FREE FROM COMBUSTIBLE MATERIALS.**

**KEEP FLOOR IN FRONT OF EQUIPMENT CLEAN AND DRY. IF SPILLS OCCUR, CLEAN IMMEDIATELY, TO AVOID THE DANGER OF SLIPS OR FALLS.**





## PROGRAMMING PURPLE PLUS CONVECTION OVENS

ECOH-PP, ECOF-PP, GCOF-PP,  
EHS-PP, ECCO-PP, GCCO-PP

### Before You Begin Programming

1. For programming new ovens, you must program at least one button (position 2 through 0) before you can delete or replace the sample program in position one.
2. If you are programming for the first time after installing a new computer board, or blanking the EPROM, you must first complete the "CPU Start Up Procedure" that came with the new computer board before programming the product buttons
3. In preparation of programming you Purple Plus Oven, first determine the cooking parameters you will be using for each product to be programmed. Use the table on the following page to record your programs prior to entering them into your unit.

### CPU Start Up Procedures

If you are programming for the first time after installing a new computer board, or needed to blank the EPROM, you will be asked to complete the "CPU Start Up Procedures". You will be asked to identify the oven you are using, answer NO to questions regarding Steam and Rack Rotation, and 650°F max temperature.

### Programming Procedures

PROGRAMMING PROCEDURES	
ACTION	DISPLAY
Turn the power switch on. If the oven is already on, press the Read / Clear key until the following screen is displayed.	SELECT PRODUCT OR READ/CLEAR TO PROGRAM XX:XXPM    XXXF
Enter access code "1 6 2 7 3 8".	ENTER PASSWORD OR READ/CLEAR TO DISPLAY PRODUCT
Select "B".	A: SET DATE / TIME B: PROGRAM PRODUCTS C: EDIT ACCESS CODE
Select a number from 0-9 and press the key corresponding to that number. <b>NOTE:</b> If a product Key selected already has a program, the screen will read.	PRODUCT PROGRAM MODE SELECT PRODUCT NUMBER 0-9
If a product Key dose not have a program, the screen will read.	EDIT PRODUCT? 1=EDIT OR 2=DELETE NXX TX XXXF CX XX:XX:XX PXXX F-XX
Enter a desired cooking / baking temperature. The screen will automatically advance to the next display.	ENTER COOKING TEMP 100 TO 450 F NOX T1 XXXF
Enter the cooking time and then press "E" to advance to the next screen.	ENTER COOKING TIME HR:MIN:SEC NOX T1 XXXF CO
Enter the desired cooking curve. (Refer to sections 6.3 and 6.7 for more detail)	ENTER COOKING CURVE 0 TO 100% NOX T1 XXXF CXX XX:XX:XX PXXX F-XX

## PROGRAMMING PURPLE PLUS CONVECTION OVENS

ECOH-PP, ECOF-PP, GCOF-PP,  
EHS-PP, ECCO-PP, GCCO-PP

### Programming Procedures continued

PROGRAMMING PROCEDURES CONTINUED	
<p>Select Fan speed. (Hi=1700 rpm, Low=1400)</p>	<p style="text-align: center;">ENTER FAN SPEED 1=HI 2=LOW NOX T1 XXXF CXX XX:XX:XX PXXX F-XX</p>
<p>Select Fan Pulse rate. (0 to 100%). 0=off unless calling for heat. 100=on at all time. <b>NOTE:</b> Any number between 0-100 means that the fan will be on that many number of seconds in a 100-second block. (E.g. 67%= on for 67 seconds in a 100 second block)</p>	<p style="text-align: center;">ENTER FAN PULSE RATE  1 TO 100%  NOX T1 XXXF CXX XX:XX:XX PXX F-XX</p>
<p>If you press 1 you will go through the same sequence as outlined above. If you press 2 the next display will automatically appear.</p>	<p style="text-align: center;">CONTINUE TO TIER 2  1=YES 2=NO NOX T1 XXXF CXX XX:XX:XX PXXX F-XX</p>
<p>If you wish to continue programming a separate menu item, press "B" and repeat the sequence. If you have completed your programming requirements, press Read/Clear button until the next display appears</p>	<p style="text-align: center;">A: SET DATE / TIME B: PROGRAM PRODUCTS C: EDIT ACCESS CODE</p>
<p>To begin using your oven, press the appropriate Product Select button. Refer to your Daily Operations Section of your Operations Manual to learn how to use your program.</p>	<p style="text-align: center;">SELECT PRODUCT OR  READ/CLEAR TO PROGRAM XX:XXPM XXXF</p>



## MAINTENANCE

- Oven interiors should be wiped down daily and thoroughly cleaned weekly using warm water and mild detergent. **DO NOT use caustic cleaners.**
- The appliance should be thoroughly checked at six-monthly intervals by a qualified technician (heating unit, mechanical stability, corrosion...) with particular emphasis on all control and safety devices.

## CLEANING

- Always start with a cold oven.
- The stainless exterior can easily be cleaned using stainless steel cleaner.
- Always follow the cleaner manufacturer's instructions when using any cleaner.
- Care should be taken to prevent caustic cleaning compounds from coming in contact with the fan wheel.
- The oven racks, rack slides, may be cleaned outside the oven cavity using oven cleaner.
- Using any harsh chemicals will result in the removal of the ETC coating and etching of the porcelain below it. The oven interior should only be cleaned using a mild soap and a non metal scouring pad.  
**DO NOT use caustic cleaners.**
- Always apply stainless steel cleaners when the oven is cold and rub in the direction of the metal's grain.



**WARNING**

**KEEP WATER AND SOLUTIONS OUT OF CONTROLS. NEVER SPRAY OR HOSE CONTROL CONSOLE, ELECTRICAL CONNECTIONS, ETC.**



**CAUTION**

**MOST CLEANERS ARE HARMFUL TO THE SKIN, EYES, MUCOUS MEMBRANES AND CLOTHING. PRECAUTIONS SHOULD BE TAKEN TO WEAR RUBBER GLOVES, GOGGLES OR FACE SHIELD AND PROTECTIVE CLOTHING.**

**CAREFULLY READ THE WARNING AND FOLLOW THE DIRECTIONS ON THE LABEL OF THE CLEANER TO BE USED.**

**NEVER LEAVE A CHLORINE SANITIZER IN CONTACT WITH STAINLESS STEEL SURFACES LONGER THAN 10 MINUTES. LONGER CONTACT CAN CAUSE CORROSION.**

## Troubleshooting

### Symptoms & Possible Causes

The following are charts of Symptoms and Possible Causes to aid in diagnosing faults with your unit.

Refer to the symptoms column to locate the type of failure then to the Possible Cause for the items to be checked.

To test for a possible cause refer to test to identify test procedures. Test indicated with an "\*" should be done by a Lang factory authorized service representative.

Symptoms	Possible Cause	Possible Cause	Test	
<b>Power indicator is not lit</b>	No power to cord outlet	<b>Product is cooked too long</b>	No test available, operational condition	
	Oven unplugged from outlet		<b>Failed Probe</b>	Check probe for proper resistance*
	Failed Power cord or plug	<b>Failed Circuit board</b>		Confirm that Circuit board is getting correct voltage and putting out correct voltage*
	Failed power switch			<b>Failed Transformer</b>
	Failed indicator light	<b>Failed Contactor</b>	Remove the wires from the contactor coil and check for continuity across the contactor coil connection*	
<b>Oven will not heat</b>	Power Switch is not "ON"		Ensure the contactor moveable points move freely up and down*	
	Failed Transformer		<b>Failed Motor</b>	Confirm that motor is getting correct voltage*
	Failed Probe			<b>Failed or disconnected safety thermostat</b>
	Failed Circuit board		<b>Failed Element</b>	
	Failed Contactor			
	Failed Over-temperature Thermostat			
<b>Oven motor will not run</b>	Failed Element			
	Power Switch is not "ON"			
	Failed Transformer			
	Failed Contactor			
<b>Product burning</b>	Failed Motor			
	Product is cooked too long			
	Failed Probe			
<b>Product is under done</b>	Failed Circuit board			
	Product is not cooked long enough			
	Failed Probe			
	Failed Circuit board			

**NOTICE** If an item on the list is followed by an asterisk (\*), the work should be done by a Lang factory authorized service representative.



**USE OF ANY REPLACEMENT PARTS OTHER THAN THOSE SUPPLIED BY LANG OR THEIR AUTHORIZED DISTRIBUTORS CAN CAUSE BODILY INJURY TO THE OPERATOR AND DAMAGE TO THE EQUIPMENT AND WILL VOID ALL WARRANTIES.**

**NOTICE** Service on this or any other Lang appliance must be performed by qualified personnel only. Consult your Lang Authorized Service Agent Directory. You can call our tech service number 314-678-6315 or visit our website [www.langworld.com](http://www.langworld.com) for the service agent nearest you.



**BOTH HIGH AND LOW VOLTAGES ARE PRESENT INSIDE THIS APPLIANCE WHEN THE UNIT IS PLUGGED/WIRED INTO A LIVE RECEPTACLE. BEFORE REPLACING ANY PARTS, DISCONNECT THE UNIT FROM THE ELECTRIC POWER SUPPLY.**

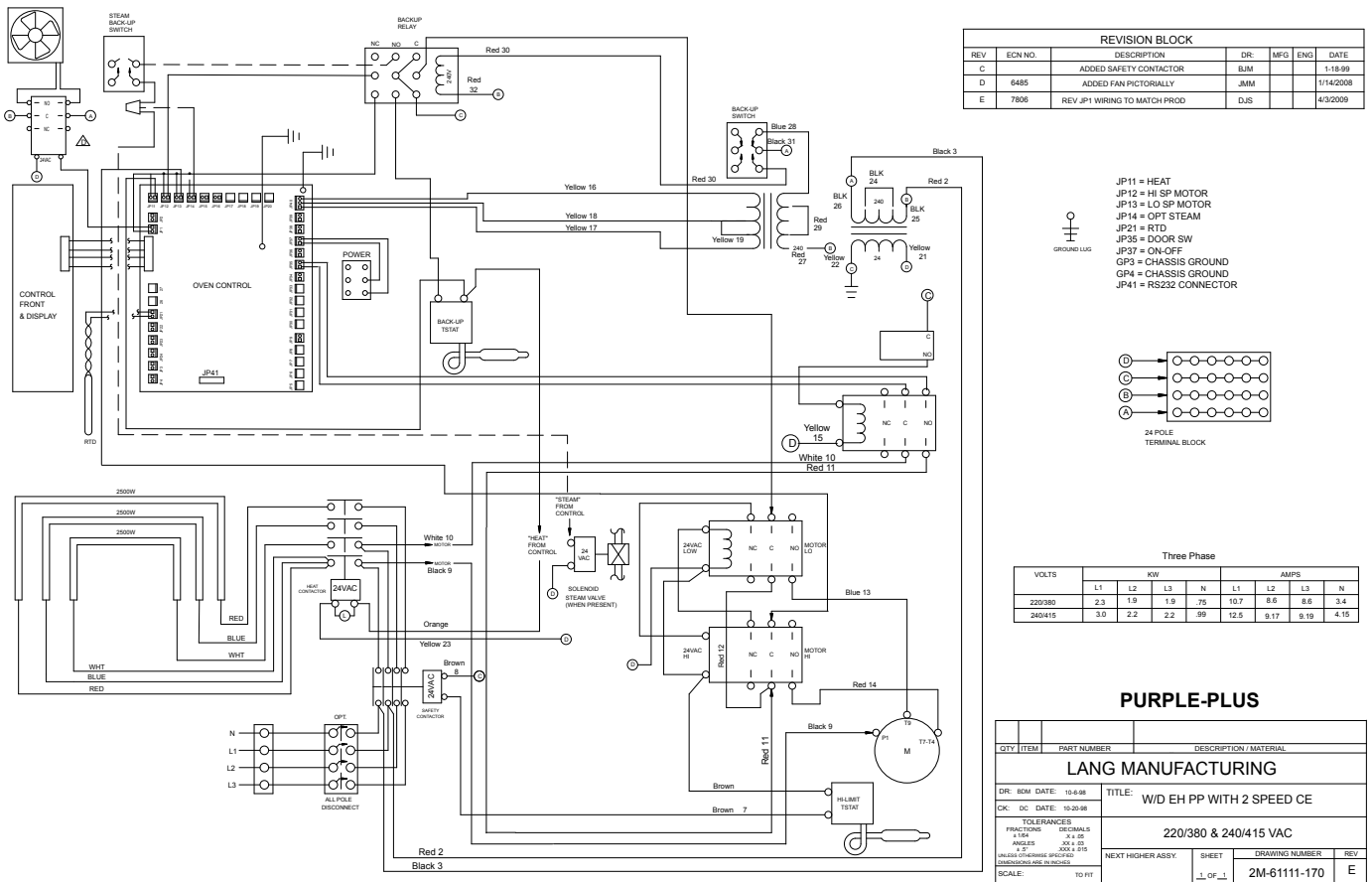
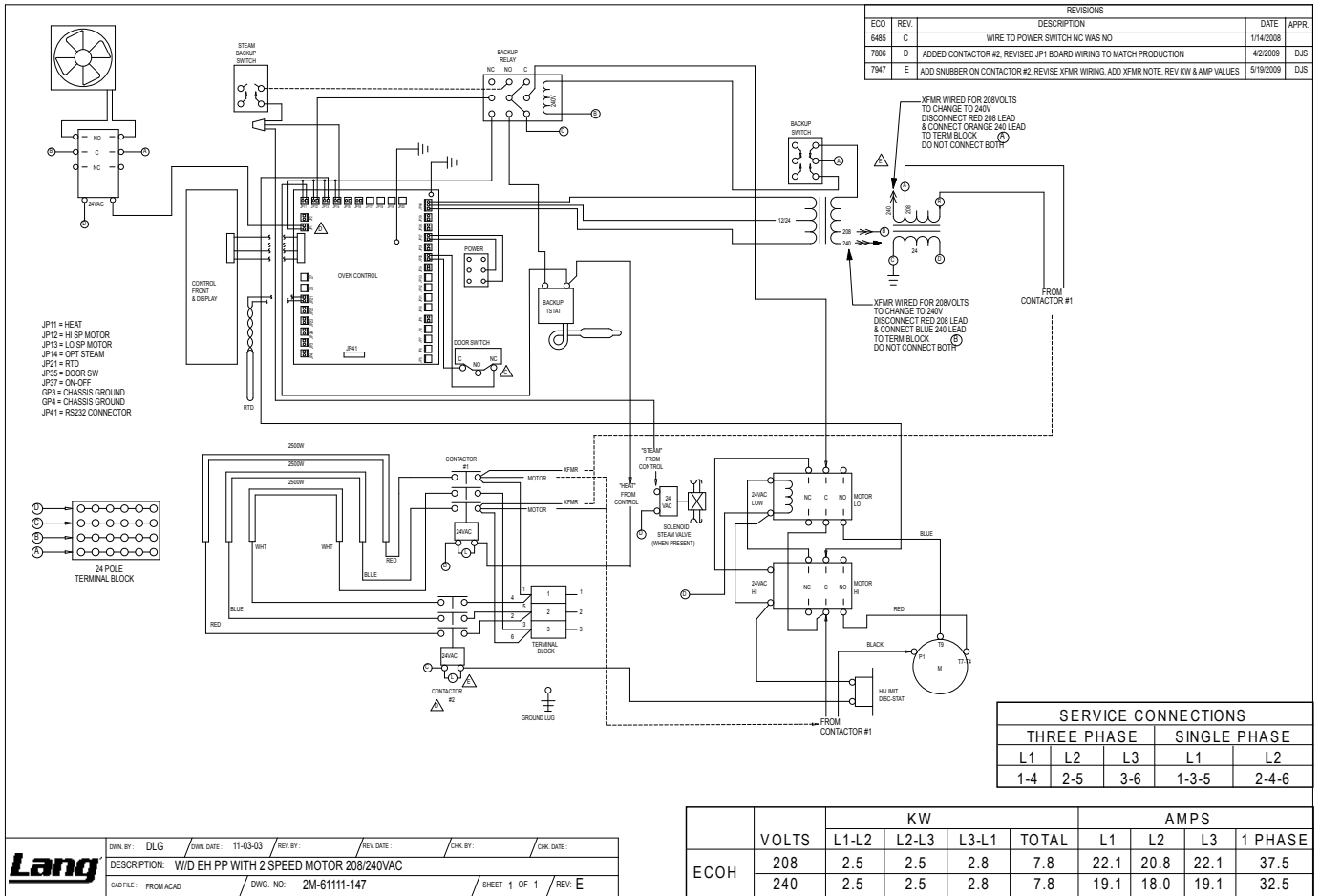

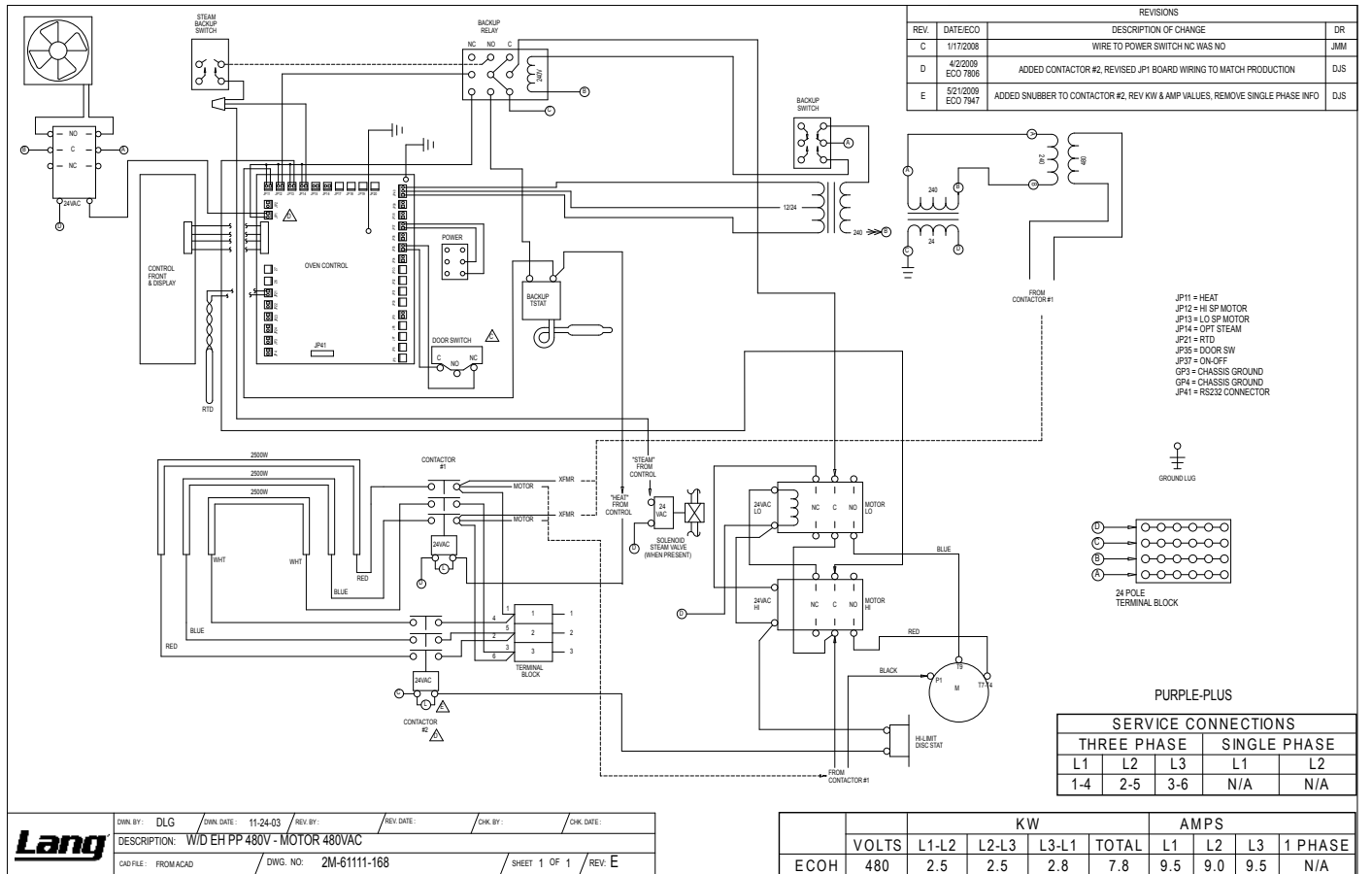
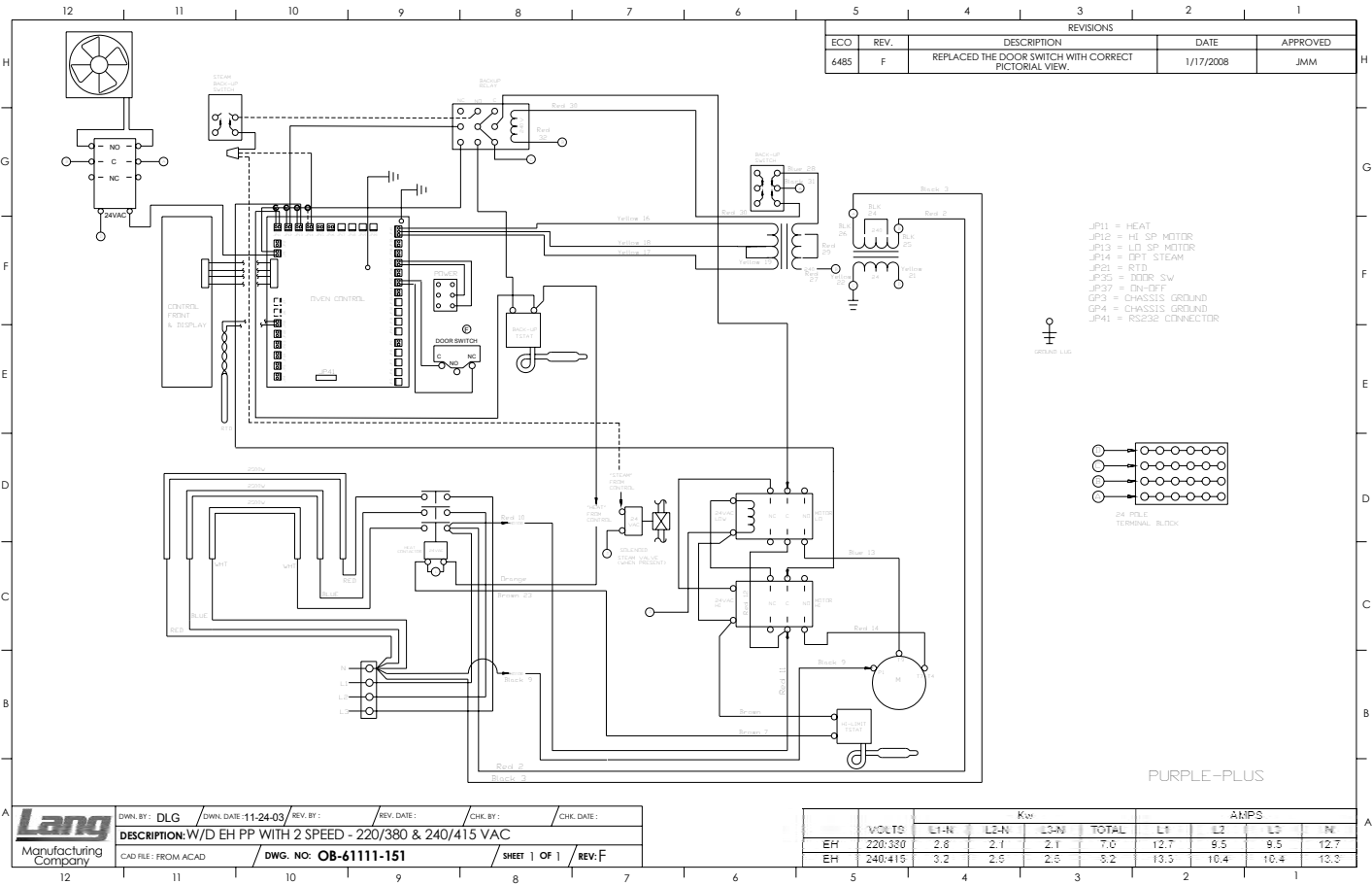



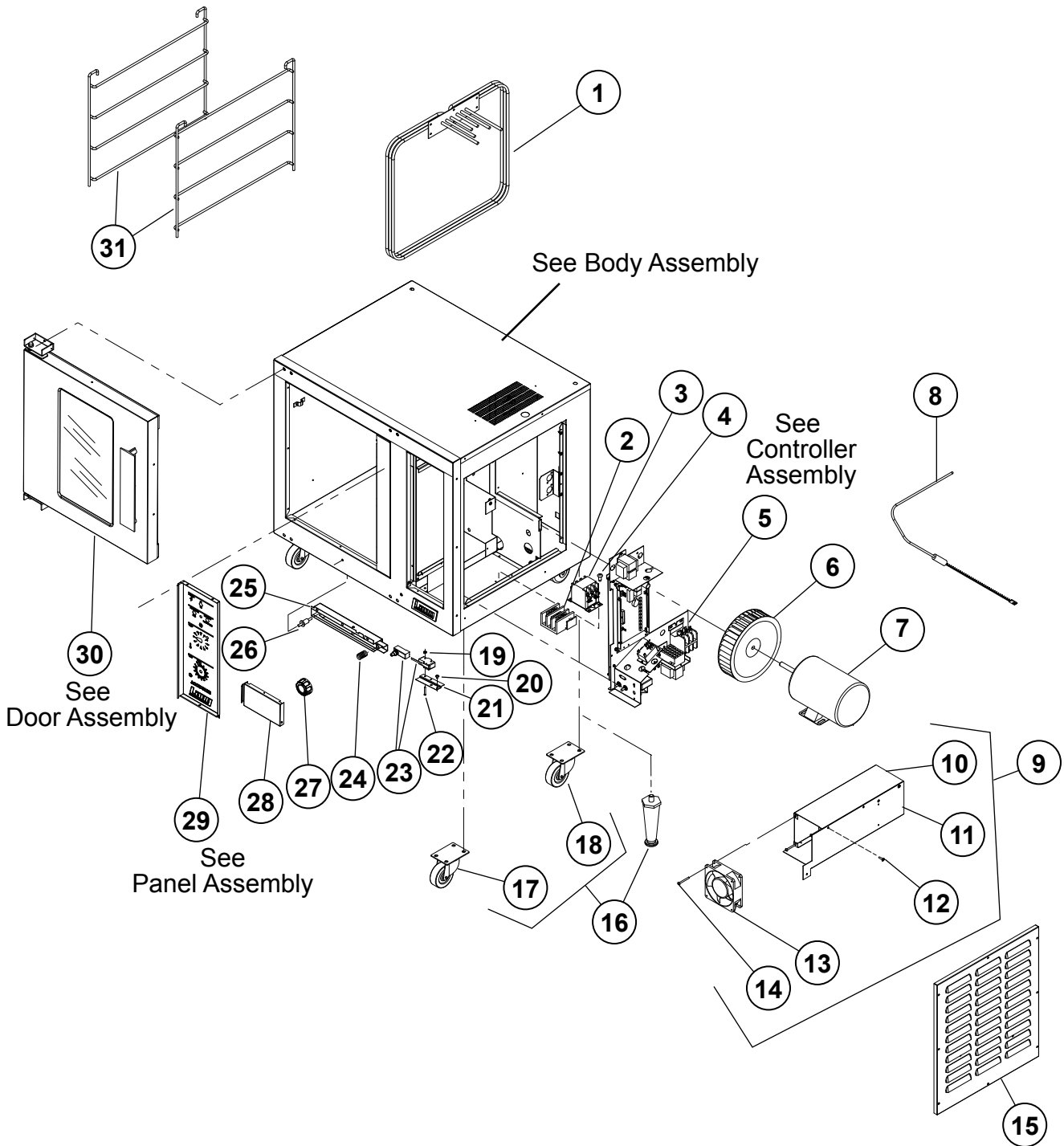

ECOH Complete Assembly

**Lang**<sup>®</sup>

SK2320

Rev. B

6/1/2009

# PARTS LIST

March 24, 2015, Rev E

## Model No: ECOH & RCOH, AP, PP & PT CONTROLS Commercial & Marine Half Size Economy Convection Oven

Fig No	PART NO	Qty	DESCRIPTION	Application
1	2N-11090-20	1	ELMNT EHS 208V 7.5KW	208V/208VM
	2N-11090-21		ELMNT EHS 240V 7.5KW	240V, ECOH-AP208FA, ECOH-AP2/3FA, ECOH-PP2/4BK, ECOH-AP-2/3, RCOHAP-2/3V
	2N-11090-22		ELMNT EHS OVEN 480VAC 7.5KW	440VM, 480V, 480VM
	2N-11090-23		ELMNT EHS OVEN 208VAC 5.0 KW	RCOHAP-208KR, RCOHRAP208KR, RCOHPT-208CF, RCOH-AP-208CF
	2N-11090-24		ELMNT EHS OVEN 240VAC 5.0	ECOH-AP240CF, RCOHAP-240CF, RCOHPT-240CF
2	2E-30500-15	1	TRM BLOCK 4 POLE 115AMP	ECOH-AP-2/3
	2E-30500-07		TRM BLOCK 3PLELRGE 125AMP	ECOHPT208CFR, RCOHPT-208CF, RCOHPT-240CF, RCOHAP-208CF
	2E-30500-09		TRM BLOCK 3 POLE SMALL 95	ECOH-AP-208V/208M/240V/208DR, ECOH-AP-480V480/M, RCOHAP-208V/VM, RCOHAP-240VM, RCOHAP-440VM, RCOHAP-480V/VM, RCOHAP-480V/480M, RCOHRAP-480V/480M, RCOHPT-440VM
3	2E-30700-06	1	CONTC3POLE35A, 24VAC	ECOH-AP-208V/VM, 240V/VM, 440M, 480V/VM, ECOH-AP2/3FA, ECOH-AP208CF, ECOH-AP208DR, ECOH-PP208/240V, ECOH-PT-208/240V
4	2C-20102-08	2	SCRW PHD ST 8-32X.375	ECOH-AP-208V/VM, 240V/VM, 440M, 480V/VM, ECOH-AP2/3FA, ECOH-AP208CF, ECOH-AP208DR,
5	Q9-60101-767	1	PANEL EH 208/240V	ECOH-AP-208, 208M, 240V, 208DR
	Q9-EHPAP-GFA		PANEL EH 220/380V ACCU-PLUS FA	ECOH-AP208FA, ECOH-AP2/3FA
	Q9-EHPAPRT-C		PANEL EH 208/240V AP W/RT30	RCOHAP-208KR, RCOHAP-208V, RCOHRAP208KR
	Q9-EHPAP-U		PANEL EH 480 VOLT ACCU-PLUS	ECOH-AP-480M, 480V, RCOHAP-480V, 480VM, RCOHRAP-480M, 480V
	Q9-EHPPP-C		PANEL EH 208/240V PURPLE w/COOLING FAN ASSY	ECOH-PP-208V, 208BK, 208WB, 240BK, 240WB (Before 6-01-2009)
	Q9-EHPPP-C-W1		PANEL EH 208/240V PP	ECOH-PP-208V, 208BK, 208WB, 240BK, 240WB, (After 6-01-2009)
	Q9-EHPPP-C-S		PANEL EH 208/240V PURPLE w/o COOLING FAN ASSY	ECOH-PP-208V, 208BK, 208WB, 240BK, 240WB
	Q9-EHPPT-C		PANEL ASSY EHS-PT 208/240/480V	ECOH-PT, RCOHPT (Before 6-01-2009)
	Q9-EHPPT-C-W1		PANEL EH 208/240V PT	ECOH-PT, RCOHPT (After 6-01-2009)
Q9-EHPPP-CE	PANEL EH PURPLE PLUS - CE	ECOH-PP2/4BK		
6	2U-71500-06	1	BLOWER WHEEL EHS OVEN	ALL
7	2U-30200-16	1	MOTOR 1/3HP 460V/1/60HZ 2SP	ECOH-AP-480V, ECOH-AP-480M, ECOH-PT-480V, ECOH-PT480CF, ECOH-PT480MF, RCOHAP-480V, RCOHAP-480M, RCOHRAP-480M, RCOHRAP-480V, RCOHPT-440VM, RCOHPT-480CF
	2U-30200-17		MTR 1/3HP208/240V1PH2SPD	ECOH-AP-208M, ECOHAP-208V, ECOH-AP-240V, ECOH-AP208DR, ECOH-PP-208V, ECOH-PP208BK, ECOH-PP208WB, ECOH-PP240BK, ECOH-PP240WB, ECOH-PT-208V, ECOH-PT-240V, ECOH-PT208CF, ECOH-PT208MF, ECOH-PT208NT, ECOH-PT208RF, ECOH-PT208SZ, ECOH-PT208V7, ECOH-PT208WA, ECOH-PT208WD, ECOH-PT240SZ, ECOH-PT240WD, ECOHPT208CF, ECOHPT208CFC, ECOHPT208CFR, RCOHAP-208KR, RCOHAP-208V, RCOHPT-208CF, RCOHPT-208V, RCOHPT-240CF, RCOHRAP208KR, ECOH-AP208FA, ECOH-AP2/3FA, ECOH-PP2/4BK, ECOH-AP-240CF
8	2E-41100-12	1	SENSOR EHS OVEN 450 DEG	ALL
9	Q9-EH-268	AR	EH COOLING FAN ASSY	ECOH-PP-208/240V, ECOH-PT-208/240/480V, RCOHPT-208/240CF/480CF, ECOH-PP2/4BK
10	Q9-EH-268-2	1	AIR DUCT BACK	ECOH-PP-208/240V, ECOH-PT-208/240/480V, RCOHPT-208/240CF/480CF
11	Q9-EH-268-1	1	AIR DUCT FRONT	ECOH-PP-208/240V, ECOH-PT-208/240/480V, RCOHPT-208/240CF/480CF
12	2C-20103-02	6	SCRW SM PLT 10 X .5 PHLSL	ECOH-PP-208/240V, ECOH-PT-208/240/480V, RCOHPT-208/240CF/480CF

**IMPORTANT: WHEN ORDERING, SPECIFY VOLTAGE OR TYPE GAS DESIRED  
INCLUDE MODEL AND SERIAL NUMBER**

PAGE 1  
OF 2

Some items are included for illustrative purposes only and in certain instances may not be available.



# PARTS LIST

March 24, 2015, Rev E

## Model No: ECOH & RCOH, AP, PP & PT CONTROLS Commercial & Marine Half Size Economy Convection Oven

Fig No	PART NO	Qty	DESCRIPTION	Application
13	2U-30200-46	1	MTR W/FAN AXIAL 220VAC70C	ECOH-PP-208/240V, ECOH-PT-208/240/480V, RCOHPT-208/240CF/480CF
14	2C-20109-31	4	SCRW S/S 8-32 X 1-3/4 T/H PHIL	ECOH-PP-208/240V, ECOH-PT-208/240/480V, RCOHPT-208/240CF/480CF
15	Q9-60102-1368		MTR COVER EH (EH-141) & HRDW	ALL
16	2A-72500-02	4	LEG 4 SS MM	ECOH-AP208DR, ECOH-PT208V7
	2A-72500-05		LEG 4 W/BOLT DOWN ADJ	ECOH-AP-208M, RCOHAP-440/480VM, RCOHRAP-480M
	9Q-ECOH-C4	1	CASTERS (SET OF 4)	sold as an accessory with most units
	Q9-EHS-4C		CASTERS (SET OF 4)	RCOHAP-208KR, RCOHAP-208V, RCOHAP-480V, RCOHPT-208CF, RCOHPT-208V, RCOHPT-240CF, RCOHPT-480CF
17	2P-72901-17	2	CSRT SWVL W/BRK 35/16TRD	RCOHAP-208KR, RCOHAP-480V, RCOHPT-208CF
18	2P-72900-04	2	CSTER RIGID 3,5/16WTRD	RCOHAP-208KR, RCOHAP-480V, RCOHPT-208CF
19	2C-20301-10	2	NUT HEX 6-32 PLTD	ECOH, RCOH
20	2C-20101-65	2	SCRW MS PLT 10-32 X .25 THD	ECOH, RCOH
21	Q9-EH-356	1	SWITCH BRACKET	ECOH, RCOH
22	2C-20101-17	2	SCRW RND MS 6-32X1 PLTD	ECOH, RCOH
23	2E-30301-17	1	SWT MICRO PLUNGER XLH	V-27971 & W-48418, Pre 2007
	Q9-51100-18		SWITCH ARM, MICRO	ECOH, RCOH
24	2P-51001-12	1	SPRG COMPRSN.665ID X 1.4 LONG	ECOH, RCOH
25	Q9-EH-250	1	WELD SWITCH ARM	ECOH, RCOH
26	Q9-EH-350	1	SWITCH PLUNGER - ASSY	ECOH, RCOH
27	Y9-70701-18	1	KNOB ASSY 450°	ECOH-AP, ECOH-PT, ECOH-PP, RCOH-AP, RCOH-PT
28	Q9-60102-112	1	SWITCH DOOR - ASSY EH	ECOH-PP-208V
29	Q9-60101-765	1	ECOH-PT / EHS-PT CNTRL FRONT	ECOH-PT, RCOH-PT
	Q9-60101-766		ECOH-PP / EHS-PP CNTRL FRONT	ECOH-PP
30	Q9-51100-53	1	DOOR ASSY EHS/GHS WINDOW	ALL
31	2B-50200-83	2	RACK SLIDE EHS	ECOH-AP, ECOH-PT, ECOH-PP, RCOH-AP, RCOH-PT
	2B-50200-83-1		EH RACK SLIDE - PICADILLY	ECOH-AP240RS
NI	2B-50200-34	5	RACK HALF SIZE OVENS	ECOH-AP, ECOH-PT, ECOH-PP, RCOH-AP, RCOH-PT
NI	2C-20108-01	2	STACKING PINS	ALL
NI	2E-31200-02	1	LUG GROUNDING UL APPROVED	ALL
NI	2E-31800-01	6	CB 250V50A 1 POLE CRLNGSW	RCOHAP-208KR, RCOHAP-208V, RCOHPT-208CF
NI	2E-31800-04	2	CB 480V 50A 3 POLE	RCOHAP-480V
NI	2E-31800-04	1	CB 480V 50A 3 POLE	RCOHPT-440VM
NI	2E-60101-75	1	EHS CORD KIT BK/DENNY'S	ECOH-PP208BK, ECOH-PP2/4BK, ECOH-PT208PC, ECOH-AP240CF
NI	2K-70801-03	1	SNAP BUSH 3/8 SB375-4 BLK	ECOH-PP-208V
NI	2K-70801-04	AR	SNAP BUSH 3/4 SB750-10	ECOH
NI	2M-61111-135	1	WD EHS-AP 208V-240VAC	ECOH-AP-208V
NI	2M-61111-148	1	WD EHS-PP 208-240VAC 2SPD	ECOH-PP-208V
NI	2M-61111-163	1	WD EHS-AP 480V	ECOH-AP-480M
NI	Q9-60102-97	1	DOOR SEAL EH w/ mnting hardware	
NI	Q9-EH-550	1	WIRING HARNESS, ELEMENT	ALL
NI	Q9-EH-551	1	WIRING HARNESS, HIGH VOLT	ALL
NI	Q9-EH-553	1	WIRING HARNESS, LOW VOLT	ALL
NI	Q9-EH-554	1	WIRING HARNESS, PWR SWITCH	ALL

**IMPORTANT: WHEN ORDERING, SPECIFY VOLTAGE OR TYPE GAS DESIRED  
INCLUDE MODEL AND SERIAL NUMBER**

PAGE 2  
OF 2

Some items are included for illustrative purposes only and in certain instances may not be available.





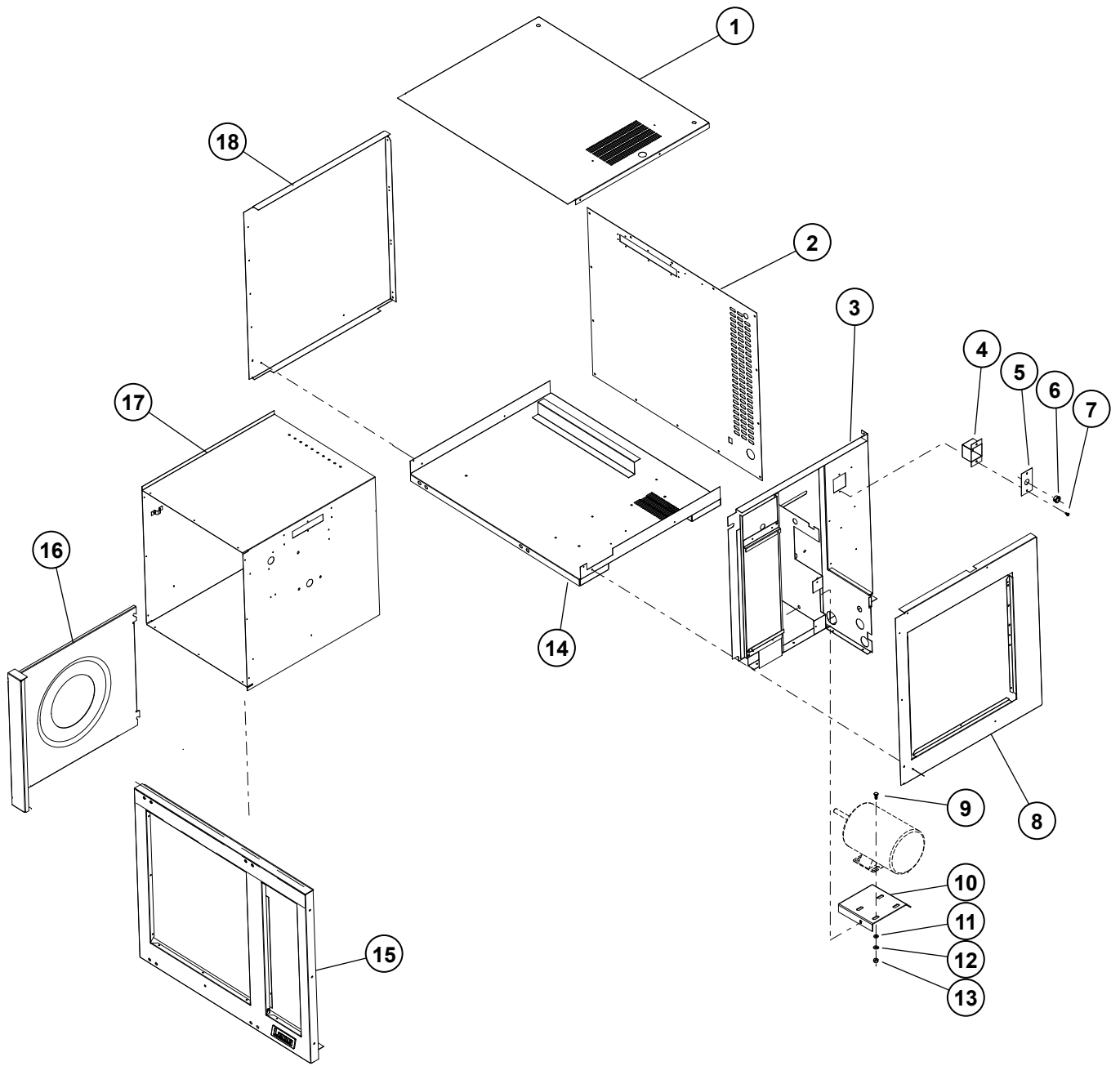

ECOH Body Assembly

**Lang**<sup>®</sup>  
SK2325 Rev. D 3/24/2015

# PARTS LIST

March 24, 2015, Rev E

**Model No: ECOH & RCOH, AP, PP & PT BODY PANELS  
Commercial & Marine Half Size Economy Convection Oven**

Key Number	Part Number	Qty Per	Description
1	Q9-60102-136	1	BODY TOP EH & HRDW ALL
2	Q9-60102-1361	1	BODY BACK EH & HRDW ALL
3	Q9-EH-119-2	1	FIREWALL - ASSY ALL
4	Q9-EH-W1237	1	SAFETY STAT BOX ASSY ALL EXCEPT MARINE APPLICATIONS
5	Q9-EH-136	1	SAFETY STAT COVER ALL
6	2K-70801-04	1	SNAP BUSH 3/4 SB750-10 BLK ALL
7	2C-20103-02	2	SCRW SM PLT 10 X .5 PHLSL ALL
8	Q9-60102-1364	1	BODY R/H SIDE EH & HRDW ALL
9	2C-20104-41	4	SCRW MACH 1/4-20X5/8 H/H ALL
10	Q9-EH-209	1	MOTOR MOUNT ALL
11	2C-20202-08	4	WSHR PLT 5/16 LOCK SPLIT ALL
12	2C-20201-09	4	WSHR PLT 5/16 FLAT SAE ALL
13	2C-20301-06	4	NUT HEX 5/16-18 PLTD ALL
14	Q9-EH-104-2	1	BOTTOM SPOT WELD ALL
15	Q9-EH-215-2	1	FRONT - ASSY REVERSIBLE ALL
16	Q9-EH-452-2	1	BAFFLE STD ALL
16	Q9-EH-452-3	1	BAFFLE ASSY STEAM STEAM
17	Q9-EH-374-3	1	CAN ASSY STD -[NEW RACK ALL
18	Q9-60102-1365	1	BODY L/H SIDE EH & HRDW ALL

**IMPORTANT: WHEN ORDERING, SPECIFY VOLTAGE OR TYPE GAS DESIRED  
INCLUDE MODEL AND SERIAL NUMBER**

PAGE 1  
OF 1

Some items are included for illustrative purposes only and in certain instances may not be available.



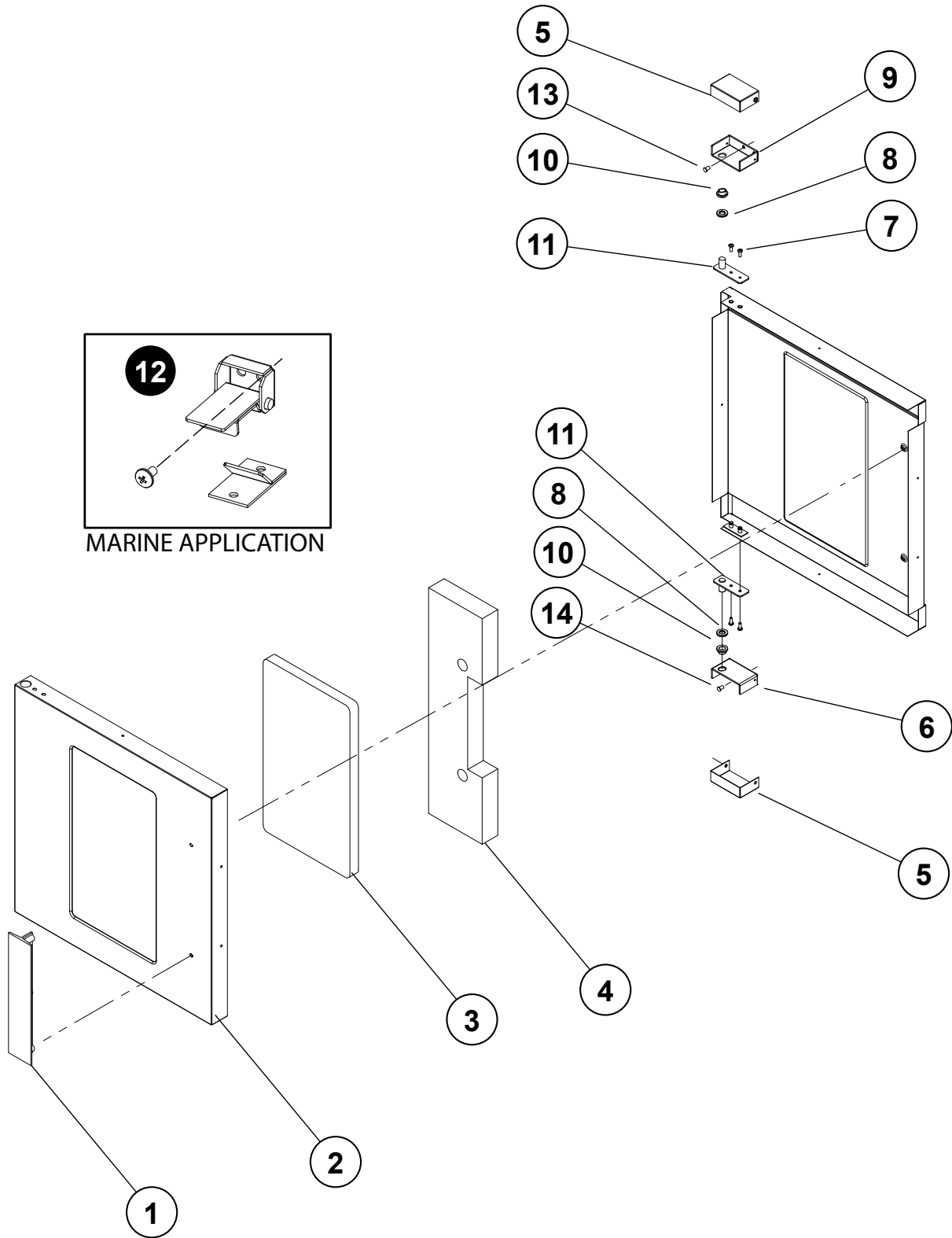

ECOH, RCOH Door Assembly

**Lang**<sup>®</sup>

SK2321 Rev. A 3/1/2012

# PARTS LIST

March 24, 2015, Rev E

**Model No: ECOH & RCOH, AP, PP & PT DOOR ASSEMBLY  
Commercial & Marine Half Size Economy Convection Oven**

Key Number	Part Number	Qty Per	Description
1	2R-50800-12	1	DOOR T HANDLE 11 1/2 LNG ALL
2	Q9-60102-1362	1	OUTER DOOR EH NO/LOGO ALL
3	2Q-71301-04	1	WINDOW ASSY 9-5/8X16-5/8 ALL
4	2H-60106-17	1	INSULATION KIT EHS DOOR - ALL
5	Q9-EH-267	2	HINGE COVER ALL
6	Q9-EH-266	1	HINGE BOTTOM ALL
7	2C-20109-15	4	SCRW PHD MS SS 10-32X1/2 ALL
8	2P-70201-01	2	BRNZBR.505IDX.8750DX.175 ALL
9	Q9-EH-265	1	HINGE TOP ALL
10	2P-70201-19	2	BRNZBRFLN1/2IDX5/8ODX3/8 ALL
11	Q9-50313-031	2	HINGE PIN - WELD ALL
12	Q9-60102-370	1	DOOR LATCH ASSY MARINE MODELS
13	2C-20109-30	2	SCRW MS SS 10-32 X .75 PH FLT ALL
14	2C-20109-43	2	SCRW SS 1/4-20 S 3/4 FLTHD PHIL ALL
COMPLETE DOOR ASSY			
	Q9-51100-53	1	COMPLETE DOOR ASSY W/WINDOW ALL
	Q9-F6-423	1	COMPLETE DOOR ASSY W/OUT WINDOW

**IMPORTANT: WHEN ORDERING, SPECIFY VOLTAGE OR TYPE GAS DESIRED  
INCLUDE MODEL AND SERIAL NUMBER**

PAGE 1  
OF 1

Some items are included for illustrative purposes only and in certain instances may not be available.



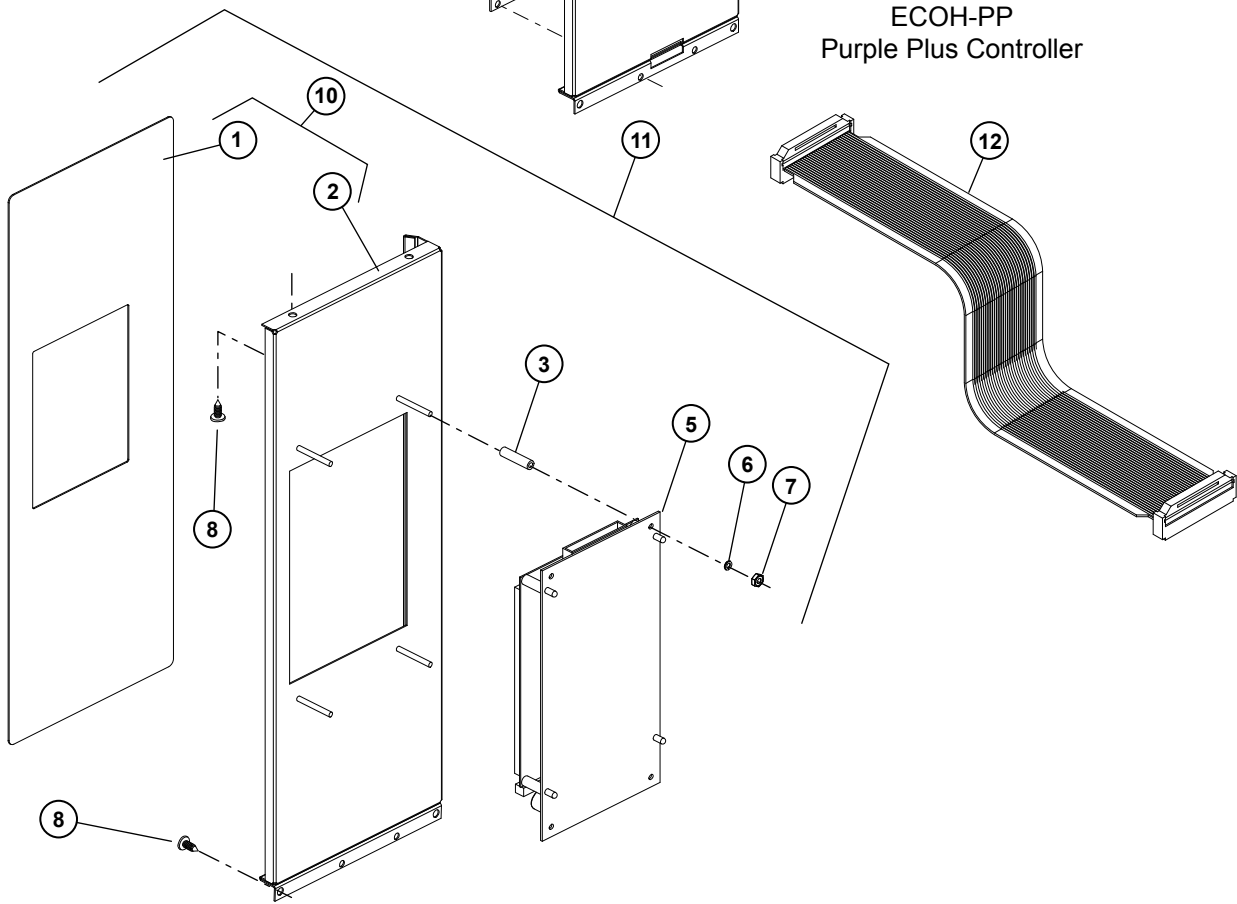
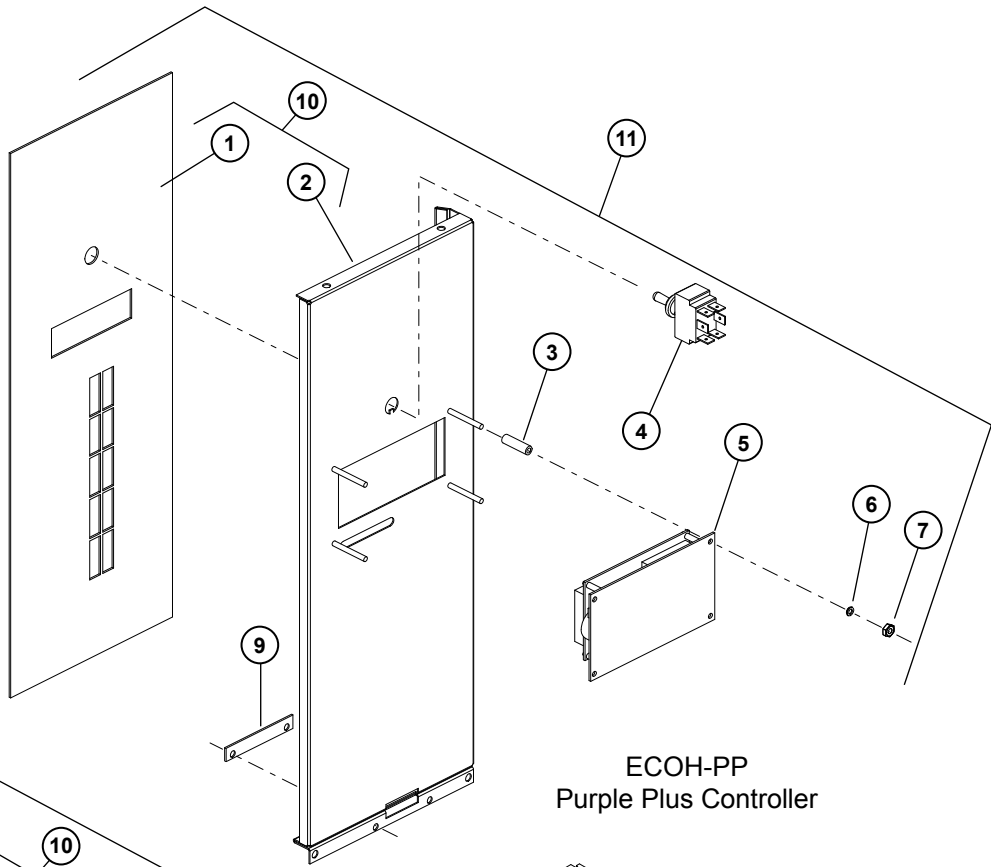

ECOH-PT & RCOH-PT  
Platinum Controller

**Lang**<sup>®</sup>

# PARTS LIST

March 24, 2015, Rev E

## Model No: ECOH & RCOH, PP & PT CONTROL ASSEMBLY Commercial & Marine Half Size Economy Convection Oven

Key Number	Part Number	Qty Per	Description	
1	2M-60301-117	1	SWITCH LBL EH 4X20	ECOH-PP
	2M-60301-118	1	SWITCH LBL EH PLATINUM	ECOH-PT, RCOHPT
2	Q9-60101-7665	1	ECOH-PP / EHS-PP CNTRL FRNT W/PROTO	ECOH-PP
	Q9-EH-516-1	1	CONTORL PANEL - EH-PT	ECOH-PT-208V
3	2A-20504-01	4	SPACER NYLON #6 1/4 X 7/8	ECOH-PP
	2A-20504-02	4	SPACER NYLON #6 1/4 X 1"	ECOH-PT, RCOH-PT
4	2E-30303-06	1	SWT TOG ON-ON DPDT BLK	ECOH-PP, ECOH-PT, RCOH-PT
5	2J-40102-A24	1	DSPLY 4X20 MDL.DA170-001 (NO CABLE)	ECOH-PP
	2J-40102-25	1	DSPLY 320X240 DB170-001	ECOH-PT, RCOH-PT
6	2C-20205-02	4	.140#6IDX.2500DX.032	ALL
7	2C-20301-10	2	NUT HEX 6-32 PLTD	ECOH-PP
	2C-20301-10	4	NUT HEX 6-32 PLTD	ECOH-PT, RCOH-PT
8	2C-20103-02	4	SCRW SM PLT 10 X .5 PHLSL TP A	ALL
9	Q9-EH-519	1	COMPUTER STRIP HOLDER	ECOH-PP
10	Q9-60101-7661	1	ECOH-PP / EHS-PP FRNT W/LABEL	ECOH-PP
	Q9-60101-7662	1	ECOH-PT / EHS-PT FRNT W/LABEL	ECOH-PT, RCOH-PT
11	Q9-60101-765	1	ECOH-PT / EHS-PT CONTROL FRONT	ECOH-PT, RCOH-PT
	Q9-60101-766	1	ECOH-PP / EHS-PP CONTROL FRONT	ECOH-PP
12	2J-31110-13	1	CABLE ASSY - RIBBON 12 PT	ECOH-PP, ECOH-PT, RCOH-PT
NI	2M-60301-128	1	PRODUCT STRIP PURP COMP	ECOH-PP
	2M-60301-W128	1	PRODUCT STRIP PURP BK	ECOH-PP208BK, ECOH-PP240BK
NI	OB-60301-46	1	OBS PRDCT STRIP-BLU/PURP COMPH	ECOH-PP

**IMPORTANT: WHEN ORDERING, SPECIFY VOLTAGE OR TYPE GAS DESIRED  
INCLUDE MODEL AND SERIAL NUMBER**

PAGE 1  
OF 1

Some items are included for illustrative purposes only and in certain instances may not be available.



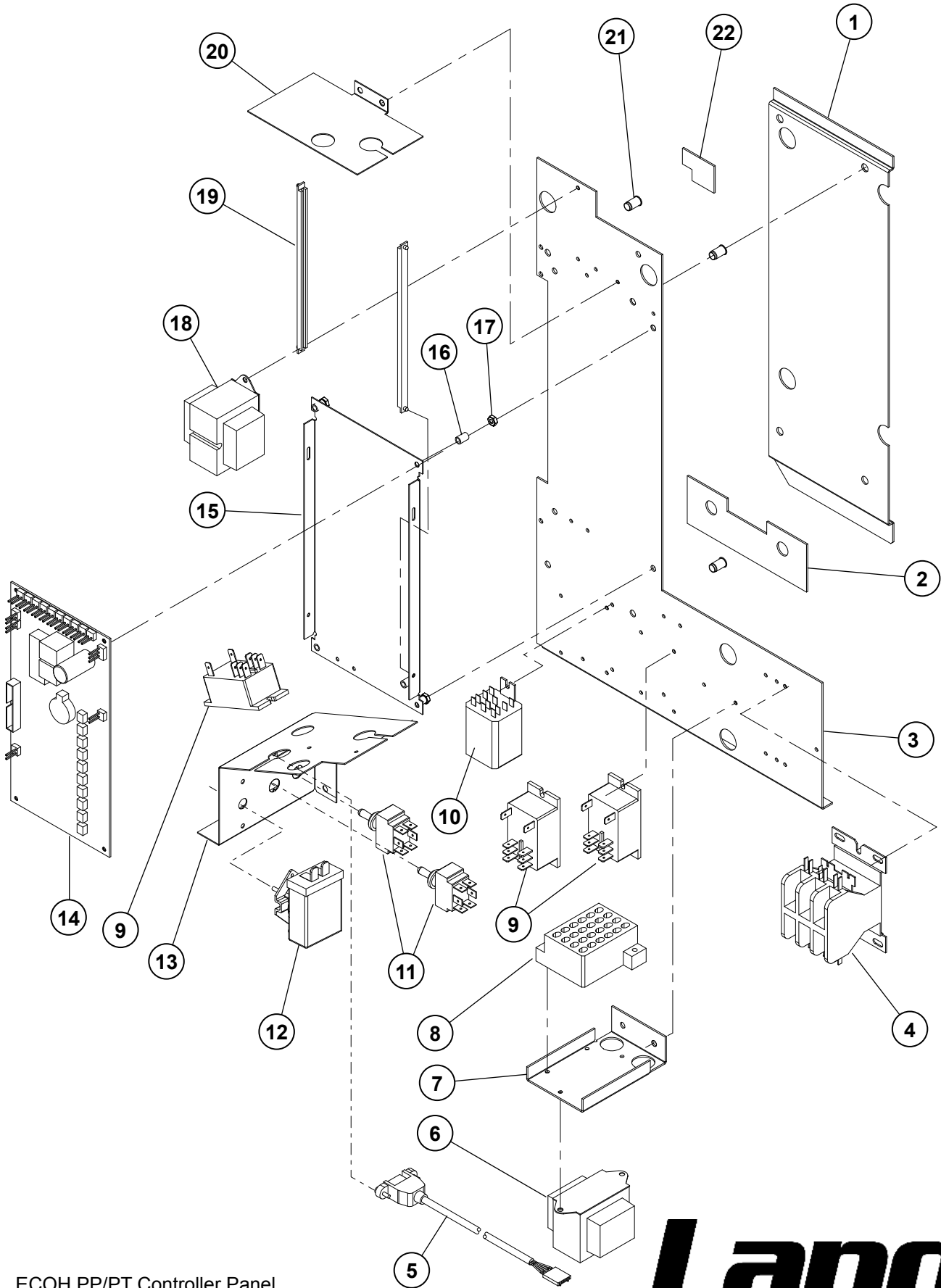

ECOH PP/PT Controller Panel



SK2323

Rev. A 7/6/2010

# PARTS LIST

March 24, 2015, Rev E

## Model No: ECOH & RCOH, PP & PT CONTROL PANEL ASSEMBLY Commercial & Marine Half Size Economy Convection Oven

Key Number	Part Number	Qty Per	Description	
1	Q9-EH-495	1	COMPUTER CONTROL SLIDE	ECOH-PP, ECOH-PT, RCOH-PT
2	Q9-EH-495-1	1	SLIDE CLIP A	ECOH-PP, ECOH-PT, RCOH-PT
3	Q9-EH-505	1	COMPONENT MOUNT C,P,PP	ECOH-PP, ECOH-PT, RCOH-PT
4	2E-30700-06	1	CONTC3POLE35A24VAC50/60HZ	ECOH-PP, ECOH-PT, RCOH-PT
5	2J-31110-W1	1	USB PNL MNT CABLE TO SOCKET	
6	2E-31400-07	1	XFORMR120-208-240/24V40VA	ECOH-PP, ECOH-PT, RCOH-PT
7	Q9-EH-507	1	TERMINAL BLOCK MOUNT	ECOH-PP, ECOH-PT, RCOH-PT
8	2E-30503-01	1	TRM BLOCK 24 POS QK CON	ECOH-PP, ECOH-PT, RCOH-PT
9	2E-30701-05	3	CONTC 2POLE 30A 24VAC P &	ECOH-PP, ECOH-PT, RCOH-PT
	2E-30701-05	4	CONTC 2POLE 30A 24VAC P &	ECOH-PP2/4BK
10	2E-30600-02	1	RELAY 240VAC 3FORMC FLNG	ECOH-PP, ECOH-PT, RCOH-PT
	2E-30600-07	1	RELAY 240VAC FLANGE MNT	ECOH-PP2/4BK
11	2E-30303-06	2	SWT TOG ON-ON DPDT BLK	ECOH-PP, ECOH-PT, RCOH-PT
	2E-30303-19	2	SWT TOG ON-ON DPDT BLK	ECOH-PP2/4BK
12	2T-30402-27	1	STAT ADJ 450 DEG 48 PILOT	ECOH-PP, ECOH-PT, RCOH-PT
13	Q9-EH-509	1	SWITCH BRACKET	ECOH-PP, ECOH-PT, RCOH-PT
14	PS-40102-W26	1	MAIN BOARD, MDL.CA170-001	ECOH-PP, ECOH-PT, RCOH-PT
15	Q9-50307-47	1	CPU MOUNT	ECOH-PP, ECOH-PT, RCOH-PT
16	2A-20501-01	5	SPCR FBR 1/4 OD #8 ID 3/8	ECOH-PP, ECOH-PT, RCOH-PT
17	2C-20301-10	2	NUT HEX 6-32 PLTD	ECOH-PP, ECOH-PT, RCOH-PT
18	Y9-31400-26-1	1	XFORMR 208-240/24-12 40VA	ECOH-PP, ECOH-PT, RCOH-PT
	2E-31400-28	2	XFORMR208-240/24VCT 40VA	ECOH-PP2/4BK
19	2E-41800-02	2	PCB GUIDE 6.675 LG	EHPPT-C, EHPPT-C,
20	Q9-EH-513	1	24V TRANSFORMER SHIELD	ECOH-PP, ECOH-PT, RCOH-PT
21	2C-20306-03	4	AVK CAD 10-32 1ST GRP	ECOH-PP, ECOH-PT, RCOH-PT
22	Q9-EH-495-2	1	SLIDE CLIP B	ECOH-PP, ECOH-PT, RCOH-PT
NI	Q9-40102-51-1	1	FILTER BOARD PHANTOM -	
NI	Q9-ECCOPPP-C	1	PANEL ECCO 208/240V	ECOH-PP
NI	Q9-ECCOPPT-C	1	PANEL ECCO 208/240V	ECOH-PT
NI	Q9-ECCOPPT-U	1	PANEL ECCO 480V PLATINUM	ECOH-PT
NI	2E-30303-05	1	SWT PLATE ON/OFF	
NI	2E-30500-15	1	TRM BLOCK 4 POLE 115AMP	ECOH-PP2/4BK, ECOH-PT2/3NT
NI	2E-30702-02	1	CONTC 4POLE 24V 25FLA CE	ECOH-PP2/4BK
NI	Q9-40705-03	VARIES	SNUB-ALL-LO VOLT (PUSH) ON	

**IMPORTANT: WHEN ORDERING, SPECIFY VOLTAGE OR TYPE GAS DESIRED  
INCLUDE MODEL AND SERIAL NUMBER**

PAGE 1  
OF 1

Some items are included for illustrative purposes only and in certain instances may not be available.

