

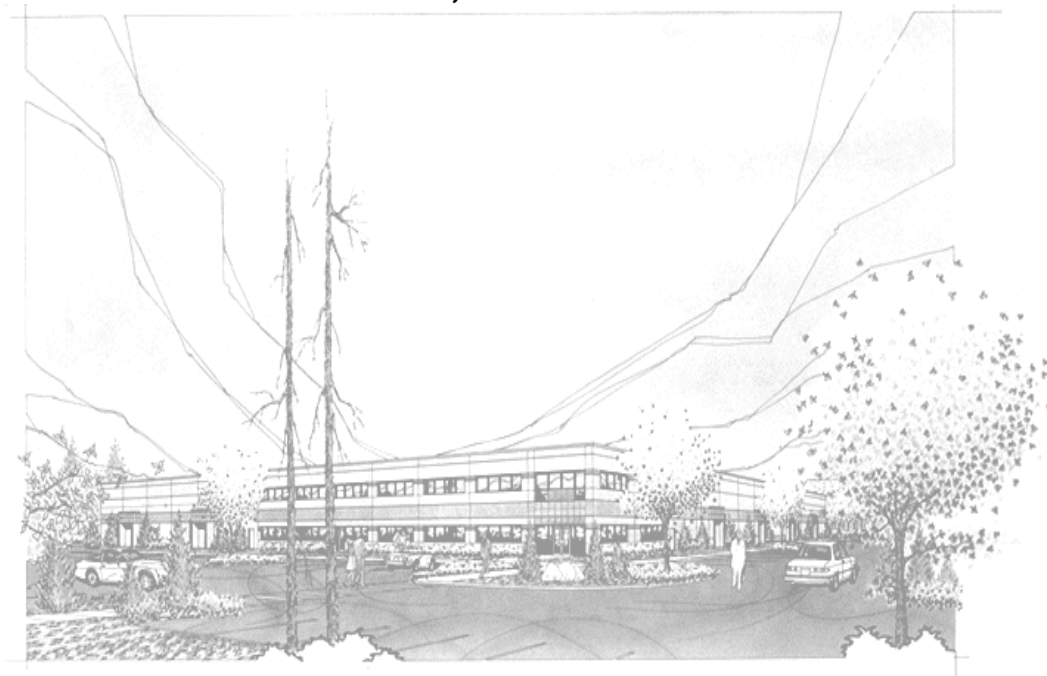

Installation, Operation, & Maintenance
Model: GCCO-T, Gas Full Size Convection Oven



THIS MANUAL MUST BE RETAINED FOR FUTURE REFERENCE. READ, UNDERSTAND AND FOLLOW THE INSTRUCTIONS AND WARNINGS CONTAINED IN THIS MANUAL.

FOR YOUR SAFETY
DO NOT STORE OR USE GASOLINE OR OTHER FLAMMABLE VAPORS AND LIQUIDS IN THE VICINITY OF THIS OR ANY OTHER APPLIANCE.

POST IN A PROMINENT LOCATION
INSTRUCTIONS TO BE FOLLOWED IN THE EVENT USER SMELLS GAS. THIS INFORMATION SHALL BE OBTAINED BY CONSULTING YOUR LOCAL GAS SUPPLIER. AS A MINIMUM, TURN OFF THE GAS AND CALL YOUR GAS COMPANY AND YOUR AUTHORIZED SERVICE AGENT. EVACUATE ALL PERSONNEL FROM THE AREA.

WARNING: IMPROPER INSTALLATION, ADJUSTMENT, ALTERATION, SERVICE OR MAINTENANCE CAN CAUSE PROPERTY DAMAGE, INJURY OR DEATH. READ THE INSTALLATION, OPERATING AND MAINTENANCE INSTRUCTIONS THOROUGHLY BEFORE INSTALLING OR SERVICING THIS EQUIPMENT.

Model #:	Purchased From:
Serial #:	Location:
Date Purchased:	Date Installed:
Purchase Order #:	For Service, Call:

TABLE OF CONTENTS

CHAPTER	PAGE
TABLE OF CONTENTS.....	3
READ FIRST.....	4
EQUIPMENT DESCRIPTION	6
UNPACKING.....	7
INSTALLATION	8
INITIAL START-UP.....	12
OPERATION.....	13
MAINTENANCE & CLEANING PROCEDURES	16
TROUBLE SHOOTING.....	17
PARTS LIST	19
WIRING DIAGRAM	20
WARRANTY	21

CAUTION: THE OVEN WEIGHS 500 LBS. FOR SAFE HANDLING, INSTALLER SHOULD OBTAIN HELP AS NEEDED, OR EMPLOY APPROPRIATE MATERIALS HANDLING EQUIPMENT (SUCH AS A FORKLIFT, DOLLY, OR PALLET JACK) TO REMOVE THE UNIT FROM THE SKID AND MOVE IT TO THE PLACE OF INSTALLATION.



CAUTION: ANY STAND, COUNTER OR OTHER DEVICE ON WHICH THE OVEN WILL BE LOCATED MUST BE DESIGNED TO SUPPORT THE WEIGHT OF THE OVEN.



CAUTION: SHIPPING STRAPS ARE UNDER TENSION AND CAN SNAP BACK WHEN CUT.



WARNING: INSTALLATION OF THE UNIT MUST BE DONE BY PERSONNEL QUALIFIED TO WORK WITH PLUMBING. IMPROPER INSTALLATION CAN CAUSE INJURY TO PERSONNEL AND/OR DAMAGE TO EQUIPMENT. UNIT MUST BE INSTALLED IN ACCORDANCE WITH ALL APPLICABLE CODES.



NOTICE: The data plate is located above control panel behind wire mesh screen. The oven serial number, gas specifications, and clearance specifications are on the data plate. This information should be carefully read and understood before proceeding with the installation.



NOTICE: The installation of any components such as a vent hood, grease extractors, fire extinguisher systems, must conform to their applicable National, State and locally recognized installation standards.



WARNING: THIS APPLIANCE IS EQUIPPED WITH A 3-PRONG (GROUNDING) PLUG FOR YOUR PROTECTION AGAINST SHOCK HAZARD AND MUST BE PLUGGED DIRECTLY INTO A PROPERLY GROUNDED 3-PRONG RECEPTACLE. DO NOT CUT OR REMOVE THIS GROUNDING PRONG FROM THE PLUG.



WARNING: CONVECTION OVENS INSTALLED WITH CASTERS MUST HAVE THE FOLLOWING: A CONNECTOR THAT COMPLIES WITH THE STANDARD FOR CONNECTORS FOR MOVABLE GAS APPLIANCES ANSI Z21.69 LATEST EDITION, A QUICK DISCONNECT THAT COMPLIES WITH THE STANDARD FOR QUICK DISCONNECT DEVICES FOR USE WITH GAS FUEL, ANSI Z21.141 LATEST EDITION, A TETHER OR OTHER MEANS TO LIMIT APPLIANCE MOVEMENT WITH OUT RELIANCE ON THE GAS SUPPLY PIPING. SECURELY ATTACH THE TETHER TO THE EYEBOLT PROVIDED AT THE REAR OF THE APPLIANCE.



WARNING: BEFORE LIGHTING, USE A SOAP AND WATER SOLUTION TO TEST ALL JOINTS FOR GAS LEAKS.

NOTICE: During the first few hours of operation you may notice a small amount of smoke coming off the oven, and a faint odor from the smoke. This is normal for a new oven and will disappear after the first few hours of use.

CAUTION: ALWAYS KEEP THE AREA NEAR THE APPLIANCE FREE FROM COMBUSTIBLE MATERIALS.

CAUTION: KEEP FLOOR IN FRONT OF EQUIPMENT CLEAN AND DRY. IF SPILLS OCCUR, CLEAN IMMEDIATELY, TO AVOID THE DANGER OF SLIPS OR FALLS.

WARNING: KEEP WATER AND SOLUTIONS OUT OF CONTROLS. NEVER SPRAY OR HOSE CONTROL CONSOLE.

CAUTION: MOST CLEANERS ARE HARMFUL TO THE SKIN, EYES, MUCOUS MEMBRANES AND CLOTHING. PRECAUTIONS SHOULD BE TAKEN TO WEAR RUBBER GLOVES, GOGGLES OR FACE SHIELD AND PROTECTIVE CLOTHING. CAREFULLY READ THE WARNING AND FOLLOW THE DIRECTIONS ON THE LABEL OF THE CLEANER TO BE USED.

NOTICE: Never leave a chlorine sanitizer in contact with stainless steel surfaces longer than 10 minutes. Longer contact can cause corrosion.

NOTICE: Service on this, or any other, LANG appliance must be performed by qualified personnel only. Consult your authorized service station directory or call the factory at 1-800-224-LANG (5264), or WWW.LANGWORLD.COM For the service station nearest you.

WARNING: BOTH HIGH AND LOW VOLTAGES ARE PRESENT INSIDE THIS APPLIANCE WHEN THE UNIT IS PLUGGED/WIRED INTO A LIVE RECEPTACLE. BEFORE REPLACING ANY PARTS, DISCONNECT THE UNIT FROM THE ELECTRIC POWER SUPPLY.

CAUTION: USE OF ANY REPLACEMENT PARTS OTHER THAN THOSE SUPPLIED BY LANG OR THEIR AUTHORIZED DISTRIBUTORS CAN CAUSE BODILY INJURY TO THE OPERATOR AND DAMAGE TO THE EQUIPMENT AND WILL VOID ALL WARRANTIES.



EQUIPMENT DESCRIPTION

Lang Model: Lang Model: GCCO-T

Exterior Construction

The oven exterior dimensions are 40" (100 cm) Wide, 32" (80 cm) High, 38" (95 cm) Deep. The Top, Front, Back, and Sides are constructed of stainless steel with an aluminized bottom.

The oven doors come standard with a double pane window.

The door handle is constructed of Stainless Steel and Phonolic Tubing.

The oven cavity is insulated with high temperature insulation for efficiency and reduced heat loss.

Interior Construction

The oven cavity dimensions are 29" (72.5 cm) Wide, 20" (50.84 cm) High, 21" (53.38 cm) Deep.

The interior of the oven is constructed of porcelainized stainless steel.

Operation

The GCCO-T oven is a forced air convection oven with a vented oven cavity.

The air is driven by a 1/3 HP fan motor.

Controls

Easy to use manual control knobs.

Pulse and two-speed fan.

Technical

The GCCO-T oven operates on either Natural Gas or Propane. **This must be specified when ordering.**

Floor space required is 48" (122.6 cm) wide, 44" (112.5 cm) deep.

The oven weighs 500 lbs. (227.28 kg).

Contact the factory for correct orifice sizes when installing oven above 4000 ft.

The GCCO-T has electronic ignition and requires a 120-Volt single-phase connection.

Receiving the Oven

Upon receipt, check for freight damage, both visible and concealed. Visible damage should be noted on the freight bill at the time of delivery and signed by the carrier's agent. Concealed loss or damage means loss or damage, which does not become apparent until the merchandise has been unpacked. If concealed loss or damage is discovered upon unpacking, make a written request for inspection by the carrier's agent within 15 days of delivery. All packing material should be kept for inspection. **Do not return damaged merchandise to Lang Manufacturing Company. File your claim with the carrier.**

Location

Prior to un-crating, move the oven as near to its intended location as practical. The crating will help protect the unit from the physical damage normally associated with moving it through hallways and doorways.

Un-crating

The oven will arrive completely assembled inside a wood frame and strapped to a skid. **Cut the straps and remove the wood frame.**

CAUTION: THE OVEN WEIGHS 500 LBS. FOR SAFE HANDLING, INSTALLER SHOULD OBTAIN HELP AS NEEDED, OR EMPLOY APPROPRIATE MATERIALS HANDLING EQUIPMENT (SUCH AS A FORKLIFT, DOLLY, OR PALLET JACK) TO REMOVE THE UNIT FROM THE SKID AND MOVE IT TO THE PLACE OF INSTALLATION.



CAUTION: ANY STAND, COUNTER OR OTHER DEVICE ON WHICH THE OVEN WILL BE LOCATED MUST BE DESIGNED TO SUPPORT THE WEIGHT OF THE OVEN.



CAUTION: SHIPPING STRAPS ARE UNDER TENSION AND CAN SNAP BACK WHEN CUT.



Remove Oven from skid and place in intended location.

INSTALLATION

WARNING: INSTALLATION OF THE UNIT MUST BE DONE BY PERSONNEL QUALIFIED TO WORK WITH PLUMBING. IMPROPER INSTALLATION CAN CAUSE INJURY TO PERSONNEL AND/OR DAMAGE TO EQUIPMENT. UNIT MUST BE INSTALLED IN ACCORDANCE WITH ALL APPLICABLE CODES.



NOTICE: The data plate is located above the control panel behind the wire mesh screen. The oven serial number, gas specifications, and clearance specifications are on the data plate. This information should be carefully read and understood before proceeding with the installation.



NOTICE: The installation of any components such as a vent hood, grease extractors, fire extinguisher systems, must conform to their applicable National, State and locally recognized installation standards.



Leg Installation

Legs are available for both the single and double deck installations. Single deck installations require a 27-inch leg. Double deck installations require 6-inch legs or casters.

To install the 27-inch legs, place some cardboard on the floor and gently tip the oven onto its back. Fasten two legs to the oven's front corners using the four 5/16 inch bolts provided in the leg kit. Lift the oven onto its front legs and block the back up using one of the 27-inch legs set upside down in the center rear of the oven body. Install the last 27-inch leg onto the oven body on the control side rear. Gently lift the oven rear, remove the leg set to support the oven center and install it on the last rear corner.

To install the 6-inch legs or casters, follow the instructions in the Leg Pad section on the following pages or in the Leg Pad box supplied with the oven.

The adjustable feet on the bottom of each leg may be screwed in or out as necessary to level the oven.

A torpedo level placed on an oven rack will assist in leveling the oven.

Stacking the Ovens

Remove all the plug buttons from the top of the lower oven.

Remove the stacking kit from the oven compartment of one oven and install the 1/4-inch plastic bushing into the top of the lower oven.

Tip the top oven backwards and install two 3/8-inch socket head bolts, found in the stacking kit, into the two front leg holes that match the holes in the top of the lower oven. Install the socket head bolts with the heads of the bolt pointing away from the oven.

Lift the top oven and gently set on top of the lower oven so that the heads of the socket head bolts nest into the holes in the top of the lower oven.

INSTALLATION CONT'D

Leg Pad Adapter

Identify the front and rear leg adapters (the front adapters have two threaded inserts, the rear has four).

Leg to Adapter Installation:

Install the leg's threaded stud through the hole in the adapter labeled "C" with the bent flange of the adapter facing away from the leg.

Screw the 3/4-inch nut supplied in the adapter kit onto the leg stud and tighten.

Caster to Adapter Installation:

Place the swivel caster against the front leg adapter with the flange of the adapter facing away from the caster.

Install the four 5/16 inch bolts through the caster base and the adapter holes labeled "A" then install the 5/16 inch nuts with washer and lock washers.

Place the rigid casters against the rear leg adapter with the flange of the adapter facing away from the caster.

Align the caster to the holes in the adapter labeled "B". NOTE: There are two sets of "B" holes set at 90° from the each other. One set will create a left rear adapter and the other set will create a right rear adapter.

Install four 5/16-inch bolts through the caster base and the adapter holes labeled "B" then install 5/16-inch nuts with lock washers and flat washers.

Adapter to Oven Installation:

Gently tip the oven onto its back. Place the front leg adapter into the front corners of the oven. The holes without the threaded inserts face the front of the oven and the flange on the adapter points toward the bottom of the oven.

The edge of the leg adapter with the threaded insert slips under the flange on the oven side, while the edge without the inserts sits on top of the threaded angle on the oven front.

Install two 3/8-inch bolts with lock washers and flat washers through the front holes "D" in the leg adapter and into the threaded inserts on the oven.

Thread one 3/8-inch bolt with lock washer and flat washer into the rear threaded hole labeled "E" on each of the leg adapters.

The forward threaded hole on the front leg adapter does not get a bolt installed.

Place the rear leg adapters into the rear corners of the oven so that the adapter is under the flange of the oven side and back. NOTE: If installing a caster place the adapter on the oven so that the casters roll forward.

Install for 3/8-inch bolts with lock washers and flat washers through the holes labeled "E" in the flange of the oven and into the threaded inserts of the leg adapter.

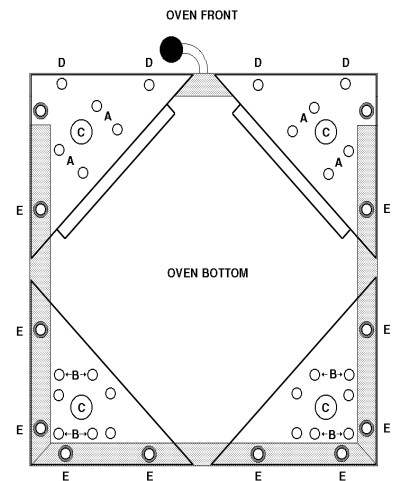

Ventilation and Clearances

Standard minimum clearance from combustible construction is as follows.

4" from side

4" from back

6" from floor

These ovens may be set directly, without legs, on a curbed base or **non-combustible** floor.

If the oven is set without legs on a **non-combustible** floor or a curbed base, maintain a 4-inch back clearance.

If the oven is set directly against a **non-combustible** back wall, maintain a 6-inch clearance to the floor.

Do not install the oven closer than 4 inches from another oven on the right hand side (control panel side).

Do not install the oven closer than 12 inches from an uncontrolled heat source (char broiler etc.) on the right side.

Keep the appliance area free and clear of combustible material and do not obstruct the flow of combustion or ventilation air.

The installation of any components such as a vent hood, grease extractors, and/or fire extinguisher systems, must conform to the there applicable nationally recognized installation standards.

WARNING: THIS APPLIANCE IS EQUIPPED WITH A 3-PRONG (GROUNDING) PLUG FOR YOUR PROTECTION AGAINST SHOCK HAZARD AND MUST BE PLUGGED DIRECTLY INTO A PROPERLY GROUNDED 3-PRONG RECEPTACLE. DO NOT CUT OR REMOVE THIS GROUNDING PRONG FROM THE PLUG.



Electrical Connection

The electrical connection must be made in accordance with local codes or in the absence of local codes with NFPA No. 70 latest edition (in Canada use: CAS STD. C22.1).

The electrical service entrance is provided by a cord and plug located at the oven back directly behind the control compartment.

Each oven requires a 115-volt grounded supply and 7.1 amps.

Supply wire size must be large enough to carry the amperage load for the number of ovens being installed. Wire size information can be found on the oven data plate.

WARNING: CONVECTION OVENS INSTALLED WITH CASTERS MUST HAVE THE FOLLOWING: A CONNECTOR THAT COMPLIES WITH THE STANDARD FOR CONNECTORS FOR MOVABLE GAS APPLIANCES ANSI Z21.69 LATEST EDITION, A QUICK DISCONNECT THAT COMPLIES WITH THE STANDARD FOR QUICK DISCONNECT DEVICES FOR USE WITH GAS FUEL, ANSI Z21.141 LATEST EDITION, A TETHER OR OTHER MEANS TO LIMIT APPLIANCE MOVEMENT WITH OUT RELIANCE ON THE GAS SUPPLY PIPING. SECURELY ATTACH THE TETHER TO THE EYEBOLT PROVIDED AT THE REAR OF THE APPLIANCE.



Gas Connection

This appliance is manufactured for use with the type of gas indicated on the data plate. Contact the factory if the gas type does not match that which is on the data plate.

All gas connections must be in accordance with local codes and comply with the National Fuel Gas Code ANSI Z223.1 latest edition.

An internal gas pressure regulator is located inside the control compartment.

Gas must be delivered to the appliance regulator at less than 1/2 pound of pressure and less than 1/2-inch water column pressure drop.

The internal regulator is preset at the factory, however, due to gas pressure variations from area to area, adjust the regulator to provide the manifold pressure indicated on the data plate. This should be 5 inches water column for natural gas and 10 inch water column for propane. A 1/8-inch NPT tap is provided on the main manifold for checking regulator pressure. Access the main manifold by removing the trim piece below the oven doors.

When replacing the 1/8-inch plug in the main manifold a joint sealant that is resistant to the action of liquid petroleum gas must be used.

The supply piping must be of sufficient size to provide 55,000 BTU/hr per oven. A 1/2-inch NPT connection is provided at the rear of the oven directly behind the control compartment. Connect each oven separately.

A gas shut off valve must be installed to the oven(s) and located in an accessible area.

This appliance and its individual shutoff valve must be disconnected from the gas supply piping system during any pressure testing of that system at test pressures in excess of 1/2 PSIG and the appliance must be isolated from the gas supply piping system by closing its individual manual shutoff valve during any pressure testing of the gas supply system at test pressures equal to or less than 1/2 PSIG.

Test for gas leaks. Use a commercial leak detector or a soap and water solution.

Flu Installation

A flu extension must be installed on the lower oven of a stacked set.

The extension attaches to the flu opening of the lower oven and directs the flu products into the flu opening of the upper oven.

This extension must be installed.

The ovens may now be set into position. Be careful if sliding the ovens, they are not designed to slide over cracks or obstructions in the floor.

INITIAL START UP

WARNING: BEFORE LIGHTING, USE A SOAP AND WATER SOLUTION TO TEST ALL JOINTS FOR GAS LEAKS.



Pre-Power On

After the oven is installed and connected to power & gas, prior to turning on, verify the following:

- The doors open and close freely.
- All racks are in the oven correctly.
- All packing materials have been removed from the inside of the oven.

Power On

The pilot burner is electronically ignited. When the oven power switch is turned On the pilot will light.

There is a lockout safety feature on the spark ignition module. If, during the initial start-up, the pilot does not light within 30 seconds the module will turn off all gas to the pilot burner. To reset the spark module, turn Off the power switch for 10 seconds then turn the switch back On. This may need to be repeated several times during the initial start-up until gas is present at the pilot burner.

NOTICE: During the first few hours of operation you may notice a small amount of smoke coming off the oven, and a faint odor from the smoke. This is normal for a new oven and will disappear after the first few hours of use.



OPERATION

Control Panel

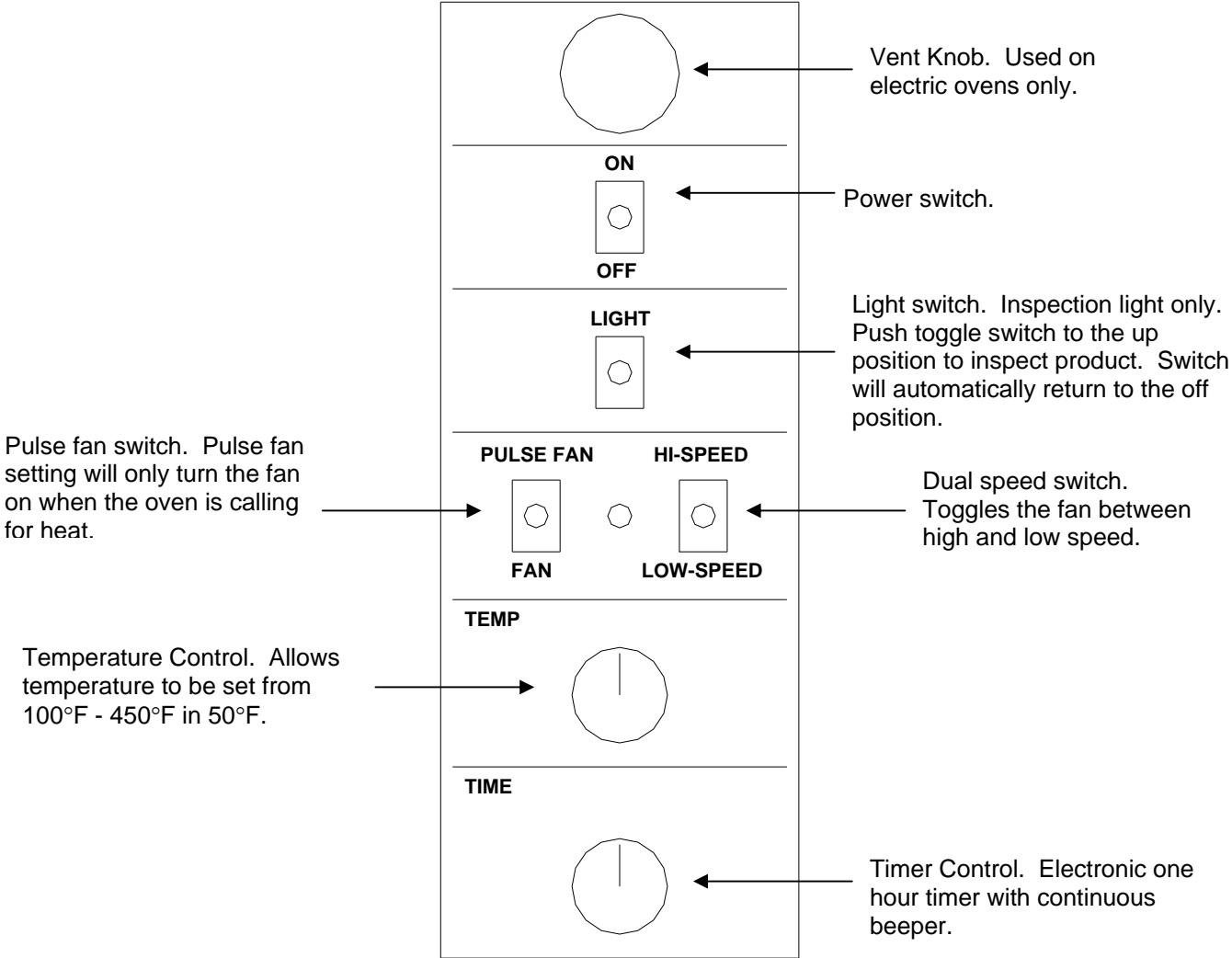

Typical Operation Sequence

ACTION	RESULT
Turn power switch to ON.	
Adjust proper temperature, between 140 & 450 degrees and allow to preheat up to 20 minutes.	Oven begins heating.
Open oven doors and insert product, set timer up to 60 minutes.	Timer begins counting down.
Timer beeps continuously when done.	Product should now be done.

Hints & Suggestions

Convection ovens constantly circulate air over and around the product. This strips away the thin layer of moisture and cool air from around the product allowing heat to penetrate more quickly.

Cooking times can be shortened and cooking temperatures can be reduced.

To convert standard deck oven recipes, reduce the temperature 50 degrees and the time by 25%. Make minor adjustments as necessary.

The lower the oven temperature the more even the bake.

Always weigh your product. This will give you a more consistent size, color and quality.

Check the product near the end of the initial cooking cycle by turning on the oven light and looking through the oven door windows.

Do not open the oven doors during baking as this will change the baking characteristics of the oven and make it difficult to determine a final program.

If the product is overdone on the outside and underdone on the inside, reduce the baking temperature.

If the product is pulling away from the edge of the pan, the temperature is too high or the cooking time too long.

The convection is a mechanical piece of equipment. The same control settings will always give the same results. If the results vary, problems may be because of product preparation.

OPERATION CONT'D

Loading

When loading and unloading the oven, stage products and racks so the oven doors are opened for the least amount of time.

Be sure that racks are level within the oven.

Bent or warped pans can greatly affect the evenness of the cook or bake.

If using baker's parchment, be sure the parchment does not blow over the product. The will create a uneven bake.

Load each shelf evenly. Spaces should be maintained equally between the pan and oven walls, front and back.

Do not overload pan's this will create a uneven bake.

For best baking results, load the oven from the center out during random loading.

CAUTION: ALWAYS KEEP THE AREA NEAR THE APPLIANCE FREE FROM COMBUSTIBLE MATERIALS.

CAUTION: KEEP FLOOR IN FRONT OF EQUIPMENT CLEAN AND DRY. IF SPILLS OCCUR, CLEAN IMMEDIATELY, TO AVOID THE DANGER OF SLIPS OR FALLS.



MAINTENANCE & CLEANING

WARNING: KEEP WATER AND SOLUTIONS OUT OF CONTROLS.
NEVER SPRAY OR HOSE CONTROL CONSOLE.

CAUTION: MOST CLEANERS ARE HARMFUL TO THE SKIN, EYES, MUCOUS MEMBRANES AND CLOTHING. PRECAUTIONS SHOULD BE TAKEN TO WEAR RUBBER GLOVES, GOGGLES OR FACE SHIELD AND PROTECTIVE CLOTHING. CAREFULLY READ THE WARNING AND FOLLOW THE DIRECTIONS ON THE LABEL OF THE CLEANER TO BE USED.

NOTICE: Never leave a chlorine sanitizer in contact with stainless steel surfaces longer than 10 minutes. Longer contact can cause corrosion.



Cleaning

- Always start with a cold oven.
- The stainless exterior can easily be cleaned using Lang Mfg. Prime Shine (72804-41) oven cleaner.
- Always follow the cleaner manufacturer's instructions when using any cleaner.
- Care should be taken to prevent caustic cleaning compounds from coming in contact with the blower wheel.
- The oven racks, rack slides, and interior may be cleaned using Lang Mfg. Foam Deluxe (72804-36) oven cleaner.
- Discoloration or heat tint may be removed using Lang Mfg. Carbon Release (72804-32) oven cleaner.
- Always apply these cleaners when the oven is cold and rub in the direction of the metal's grain.

Calibration

Calibration Check

- Place thermometer or thermocouple in the center of oven cavity.
- Set thermostat to 350°.
- Allow the oven to Preheat for at least half an hour.
- Note cycle on temperatures and cycle off temperatures for 3 cycles. (Red indicator light indicates when oven is calling for heat)
- After 3 cycles average the temperature. (Add all six temperatures and divide by 6)

Calibration Adjustment

- A 1/16" flat blade screwdriver with a 2" shaft is required to make adjustments on the thermostat.
- Maintain the oven temperature at 350°.
- Without turning the thermostat, remove the knob.
- Locate the adjustment screw at the base of the shaft and insert the screwdriver.
- Grasp the shaft and turn the screwdriver. Counter clockwise to increase and clockwise to decrease (1/8 of a turn will move the temperature 5-7 ° in either direction).
- Reinstall the oven knob and recheck the oven temperature.

TROUBLESHOOTING

Symptoms

What follows is a chart of Symptoms and Possible Causes to aid in diagnosing faults with the oven.

Refer to the Symptoms column to locate the type of failure then to the Possible Cause for the items to be checked.

To test for a possible causes refer to the TEST section and locate the Possible Cause then refer to test to identify test procedures.

SYMPTOM	POSSIBLE CAUSE
Power indicator is not lit.	<ul style="list-style-type: none">• No power to cord outlet• Oven unplugged from outlet• Failed power cord or plug• Failed power switch• Failed indicator light• Failed pilot ignition
Oven will not heat	<ul style="list-style-type: none">• Power Switch is not "ON"• Failed Pilot ignition• Failed Thermostat• Failed Contactor• Failed Centrifugal switch in Motor• Failed Motor• Failed Over-temperature Thermostat• Failed Valve
Product burning	<ul style="list-style-type: none">• Product is cooked too long• Failed Thermostat
Product under done	<ul style="list-style-type: none">• Product is not cooking long enough• Failed thermostat

TROUBLESHOOTING CONT'D

TESTS

NOTICE:

Service on this, or any other, LANG appliance must be performed by qualified personnel only. Consult your authorized service station directory or call the factory at 1-800-224-LANG (5264), or WWW.LANGWORLD.COM For the service station nearest you.



WARNING:

BOTH HIGH AND LOW VOLTAGES ARE PRESENT INSIDE THIS APPLIANCE WHEN THE UNIT IS PLUGGED/WIRED INTO A LIVE RECEPTACLE. BEFORE REPLACING ANY PARTS, DISCONNECT THE UNIT FROM THE ELECTRIC POWER SUPPLY.



If an item on the list is followed by an asterisk (*), the work should be done by a factory authorized service representative.

Possible Cause	TEST
Product is cooked too long	<ul style="list-style-type: none"> • No test available, operational condition
Failed Thermostat	<ul style="list-style-type: none"> • Check oven for correct Calibration
Failed Valve	<ul style="list-style-type: none"> • Remove the wires and check for continuity across the coil*
Failed Centrifugal switch in Motor	<ul style="list-style-type: none"> • Remove the wires and check for continuity across them while motor is turning*
Failed Motor contactor	<ul style="list-style-type: none"> • Remove the wires from the contactor coil and check for continuity across the contactor coil connection* • Ensure the contactor moveable points move freely up and down*
Failed Motor	<ul style="list-style-type: none"> • Confirm that motor is getting correct voltage*
Failed or disconnected safety thermostat	<ul style="list-style-type: none"> • Check across the thermostat connectors for continuity*
Failed Spark Module	<ul style="list-style-type: none"> • Confirm that Spark Module is getting proper voltage*

CAUTION:

USE OF ANY REPLACEMENT PARTS OTHER THAN THOSE SUPPLIED BY LANG OR THEIR AUTHORIZED DISTRIBUTORS CAN CAUSE BODILY INJURY TO THE OPERATOR AND DAMAGE TO THE EQUIPMENT AND WILL VOID ALL WARRANTIES.



GCCO-T PARTS LIST

DESCRIPTION	PART NO.
Motor 1/3 HP 115 Volt 2 Speed	30200-35
Micro Switch, Oven Door	30301-02
Switch, Toggle, On-On	30303-06
Switch, Toggle, Spring Return	30303-16
Thermostat Safety 490°F Open	30401-09
Thermostat 450°F Oven	30402-27
Terminal Strip 3 Pole	30501-02
Contactora / Relay 2 Pole 24 VAC	30701-05
Timer Electric 1 Hour 24V	30800-05
Buzzer Electric Timer 24V	30802-04
Power Cord with Molded Plug	31107-02
Transformer 115/24 VAC	31400-07
Pilot Light 28 VAC	31601-07
Lamp Socket	31602-04
Lamp 250 Volt	31603-09
Oven Lamp Lens (Watch Glass)	31604-01
Oven Lamp Lens Gasket	31604-02
Probe Pilot Flame Sensor	41100-07
Turnbuckle Assembly	50312-02
Door Left Hand	51100-45
Door Right Hand	51100-46
Panel Label	60301-101
Door Handle Assembly, Single Handle Oven	70603-15
Knob Time/Temperature Control	70701-28
Window Assembly	71301-04
Blower Wheel	71500-05
Burner "U" Tube Steel	80002-05-1
Gas Manifold	80100-07
Pilot Burner Assembly, Burner Igniter also	80201-14
Pilot Tube	60102-1381
Module Spark Igniter NG & LP	80300-08
Orifice Main Burner .0890 #43 DRL NG	80400-13
Orifice Main Burner .0595 #53 DRL LP	80400-14
Orifice Pilot Burner .010 DRL LP	80401-05
Orifice Pilot Burner .018 DRL NG	80401-10
Valve Combination Gas 24 VAC NG	80505-10
Valve Combination Gas Conversion Kit NG to LP (Includes all orifices)	60101-633
Valve Combination Gas Conversion Kit LP to NG (Includes all orifices)	60101-632
Rack	50200-20
Rack Slide	50200-93
Rack (Extra Deep)	50200-31
Rack Slide (Extra Deep)	50200-33

WIRING DIAGRAM

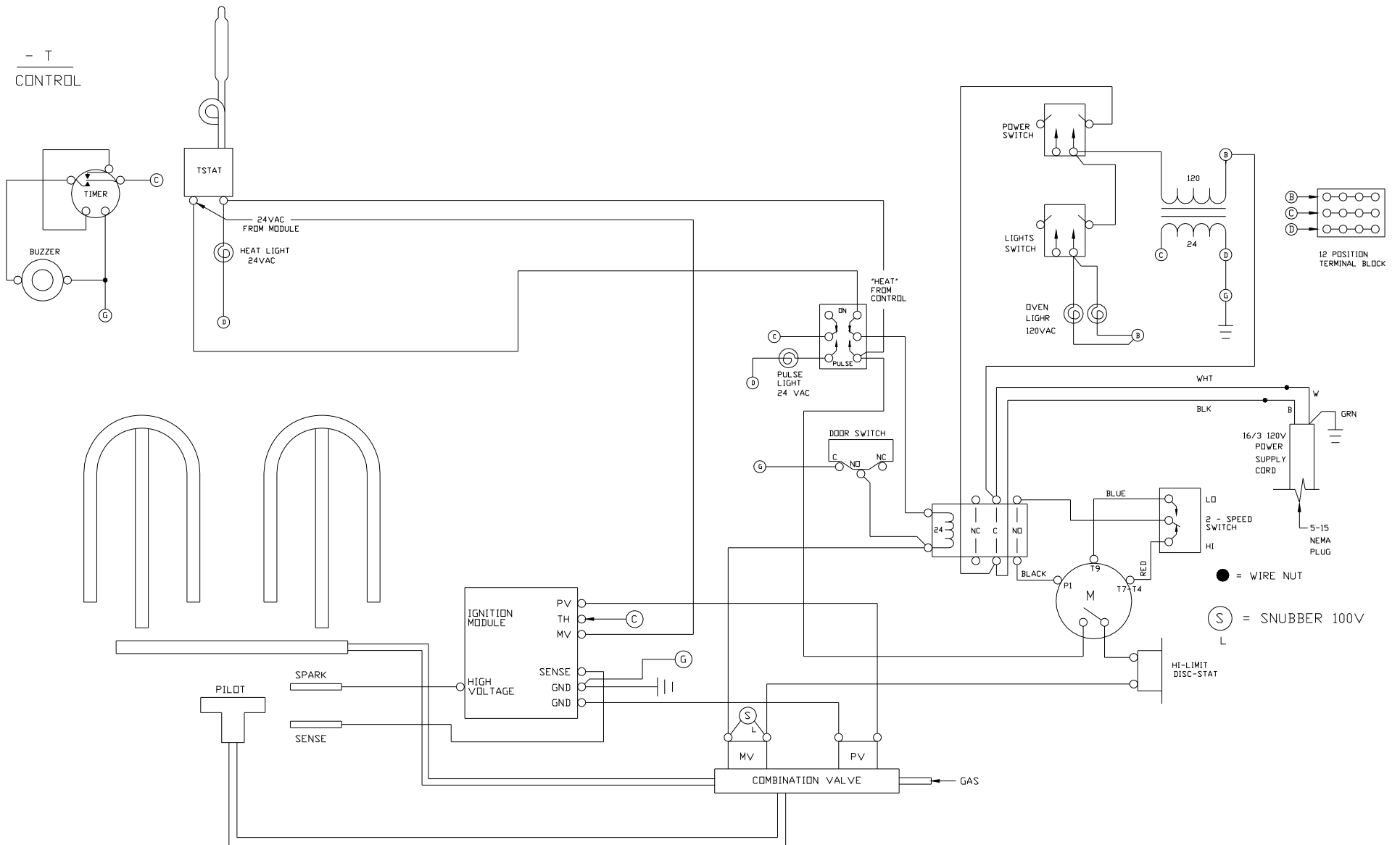

***Lang Manufacturing Limited Warranty
to Commercial Purchasers*
(Domestic U.S., Hawaii, &
Canadian Sales only.)***

Lang Manufacturing Equipment (“Lang Equipment”) has been skillfully manufactured, carefully inspected and packaged to meet rigid standards of excellence. Lang warrants its Equipment to be free from defects in material and workmanship for (12) twelve consecutive months, with the following conditions and subject to the following limitations.

I. This parts and labor warranty is limited to Lang Equipment sold to the original commercial purchaser/users (but not original equipment manufacturers), at its original place of installation, in the continental United States, Hawaii and Canada.

Quartz elements are warranted for ninety (90) days from the date of installation.

II. Damage during shipment is to be reported to the carrier, is not covered under this warranty, and is the sole responsibility of purchaser/user.

III. Lang, or an authorized service representative, will repair or replace, at Lang’s sole election, and Lang Equipment, including but not limited to, safety valves, gas and electric components, found to be defective during the warranty period. As to warranty service in the territory described above, Lang will absorb labor and portal to portal transportation costs (time & mileage) for the first (12) twelve months from the date of installation or eighteen (18) months from date of shipment from Lang Manufacturing, which ever comes first.

IV. This warranty does not cover routine general maintenance, periodic adjustments, as specified in operating instructions or manuals, and consumable parts such as quartz elements, or labor costs incurred for removal of adjacent equipment or objects to gain access to Lang Equipment. This warranty does not cover defects caused by improper installation, abuse, careless operation, or improper maintenance of equipment.

V. THIS WARRANTY IS EXCLUSIVE AND IS IN LIEU OF ALL OTHER WARRANTIES, EXPRESSED OR IMPLIED, INCLUDING ANY IMPLIED WARRANTY OF MERCHANTABILITY OR FITNESS FOR A PARTICULAR PURPOSE, EACH OF WHICH IS HEREBY EXPRESSLY DISCLAIMED. THE REMEDIES DESCRIBED ABOVE ARE EXCLUSIVE AND IN NO EVENT SHALL LANG BE LIABLE FOR SPECIAL, CONSEQUENTIAL OR INCIDENTAL DAMAGES FOR THE BREACH OR DELAY IN PERFORMANCE OF THIS WARRANTY.

VI. Lang Equipment is for commercial use only. If sold as a component of another (OEM) manufacturer’s equipment, or if used as a consumer product, such Equipment is sold AS IS and without any warranty.