TM S6161-DR-FSE-010/34931

OPERATION AND SERVICE MANUAL
FOR
ELECTRIC CONVECTION OVEN RANGE
MODEL NUMBER 9P-RT36D-440VG (ALSO KNOWN AS RF21SM-A)

LANG MANUFACTURING COMPANY
A DIVISION OF STAR MANUFACTURING INTERNATIONAL
10 SUNNEN DR
ST. LOUIS, MO 63143

DISTRIBUTION STATEMENT

THIS PUBLICATION IS REQUIRED FOR OFFICIAL USE OR FOR ADMINISTRATIVE OR OPERATIONAL PURPOSES. DISTRIBUTION IS LIMITED TO U.S. GOVERNMENT AGENCIES ONLY. OTHER REQUESTS FOR THIS DOCUMENT MUST BE REFERRED TO COMMANDER NAVAL SEA SYSTEMS COMMAND, SEA 09, WASHINGTON, DC 20362.

IDENTIFYING TECHNICAL PUBLICATION SHEET

1. IDENTIFICATION DATA: LANG MFG. CO. MODEL 9D-RT36D-440VG (ALSO KNOWN AS RF21SM-A)
2. PURPOSE: THIS TECHNICAL PUBLICATION IS ISSUED FOR THE PURPOSE OF IDENTIFYING AN AUTHORIZED TECHNICAL MANUAL FOR NAVY USE AND FOR PROVIDING SUPPLEMENTAL TECHNICAL INFORMATION.
 - A. MANUFACTURER: LANG MFG. DIVISION OF STAR MANUFACTURING INTERNATIONAL
 - B. CONTRACT NUMBER: _____
 - C. EQUIPMENT: ELECTRIC CONVECTION OVEN RANGE, MODEL NUMBER RF21SM-A
 - D. REQUISITION NUMBER: NOT REFERENCED
 - E. NATIONAL STOCK NUMBER (NSN): 7310-01-104-3349
 - F. TITLE: MAINTENANCE MANUAL FOR ELECTRIC CONVECTION OVEN RANGE MODEL NUMBER RF21SM-A
 - G. DATE OF PUBLICATION: MARCH 2001
 - H. PREPARING ACTIVITY: DEFENSE GENERAL SUPPLY CENTER
 - I. APPLICABLE TMCR NUMBER: XXXX XXXXXX-XXX
 - J. EXTENT OF PROPOSED SUPPLEMENTAL DATA (10% MAXIMUM): 1%
 - K. LIST OF TECHNICAL MANUAL FOR THIS EQUIPMENT PROCURED UNDER ANOTHER CONTACT:

3. ADDITIONAL COPIES ARE AVAILABLE FROM:

NAVAL PUBLICATION AND FORMS CENTER
5801 TABOR AVE
PHILADELPHIA, PA 19120-5099

4. COVER: THE TECHNICAL MANUAL OUTSIDE COVER SHALL CONTAIN THE FOLLOWING STATEMENTS:
PUBLISHED BY DIRECTION OF COMMANDER, NAVAL SEA SYSTEMS COMMAND
THIS PUBLICATION IS REQUIRED FOR OFFICIAL USE OR FOR ADMINISTRATIVE OR OPERATIONAL PURPOSES. DISTRIBUTION IS LIMITED TO U.S. GOVERNMENT AGENCIES ONLY. OTHER REQUESTS MUST BE REFERRED TO COMMANDER, NAVAL SEA SYSTEMS COMMAND, SEA09, WASHINGTON, DC 20362

APPROVAL AND PROCUREMENT RECORD

APPROVAL DATA FOR: LANG ELECTRIC CONVECTION OVEN RANGE MODEL NUMBER RF21SM-A.

TITLE OF MANUAL: MAINTENANCE MANUAL FOR ELECTRIC CONVECTION OVEN RANGE MODEL
NUMBER RF21SM-A

APPROVAL AUTHORITY: NAVAL SHIP SYSTEMS ENGINEERING STATION

CONTRACT NUMBER	NSN	# OF UNITS	APL/CID
	7310-01-104-3349		

REMARKS:

DATE: MARCH 2001

CERTIFICATION:

IT IS HEREBY CERTIFIED THAT THE TECHNICAL MANUAL PROVIDED UNDER CONTRACT NUMBER
_____ FOR LANG RF21SM-A HAS BEEN APPROVED BY THE APPROVAL DATA SHOWN
ABOVE:



DIRECTOR, GOV'T CONTRACTS

LANG MANUFACTURING COMPANY
FSCM / CAGE #: 34931

CHANGE RECORD

Change no.	Date	Title and/or Brief Description	Signature of Validating Officer

THE INFORMATION IN THIS MANUAL IS CRUCIAL AND MUST BE RETAINED FOR FUTURE REFERENCE. READ, UNDERSTAND AND FOLLOW THE INSTRUCTIONS AND WARNINGS CONTAINED IN THIS MANUAL.

- DANGER**

POTENTIALLY HAZARDOUS SITUATION WHICH, IF NOT AVOIDED, COULD RESULT IN DEATH.

DANGER
HIGH
VOLTAGE
- WARNING**

POTENTIALLY HAZARDOUS SITUATION WHICH, IF NOT AVOIDED, COULD RESULT IN DEATH OR SERIOUS INJURY.

- CAUTION**

POTENTIALLY HAZARDOUS SITUATION WHICH, IF NOT AVOIDED, MAY RESULT IN MINOR OR MODERATE INJURY.

- NOTICE**

Helpful operation and installation instructions and tips are present.



FOR YOUR SAFETY

DO NOT STORE OR USE GASOLINE OR OTHER FLAMMABLE VAPORS AND LIQUIDS IN THE VICINITY OF THIS OR ANY OTHER APPLIANCE.

WARNING: IMPROPER INSTALLATION, ADJUSTMENT, ALTERATION, SERVICE OR MAINTENANCE CAN CAUSE PROPERTY DAMAGE, INJURY OR DEATH. READ THE INSTALLATION, OPERATING AND MAINTENANCE INSTRUCTIONS THOROUGHLY BEFORE INSTALLING OR SERVICING THIS EQUIPMENT.















Model #:	Purchased From:
Serial #:	Location:
Date Purchased:	Date Installed:
Purchase Order #:	For Service, Call:

TABLE OF CONTENTS

<u>CHAPTER</u>	<u>PAGE</u>
1. TABLE OF CONTENTS.....	6
2. LIST OF ILLUSTRATIONS	7
3. READ FIRST	8
4. SPECIFICATION SHEET	11
5. EQUIPMENT DESCRIPTION	13
6. UNPACKING	14
7. INSTALLATION	15
8. INITIAL START-UP	16
9. OPERATION.....	17
10. MAINTENANCE & CLEANING	18
11. ILLUSTRATED PARTS BREAK DOWN	23
12. PARTS LIST	29
13. WIRING DIAGRAM.....	30
14. WARRANTY	31

LIST OF ILLUSTRATIONS

<u>ILLUSTRATION</u>	<u>PAGE</u>
1. SPECIFICATION SHEET	11
2. RANGE TOP CONFIGURATION.....	13
3. LEG LAYOUT	14
4. ASSEMBLY	15
5. ILLUSTRATED PARTS BREAKDOWN	23
6. WIRING DIAGRAM.....	30

CAUTION	EACH UNIT IS EXTREMELY HEAVY. FOR SAFE HANDLING, INSTALLER SHOULD OBTAIN HELP AS NEEDED, OR EMPLOY APPROPRIATE MATERIALS HANDLING EQUIPMENT (SUCH AS A FORKLIFT, DOLLY, OR PALLET JACK) TO REMOVE THE UNIT FROM THE SKID AND MOVE IT TO THE PLACE OF INSTALLATION.	
CAUTION	ANY STAND, COUNTER OR OTHER DEVICE ON WHICH RANGE WILL BE LOCATED MUST BE DESIGNED TO SUPPORT THE WEIGHT OF THE RANGE.	
CAUTION	SHIPPING STRAPS ARE UNDER TENSION AND CAN SNAP BACK WHEN CUT.	
DANGER	THIS APPLIANCE MUST BE GROUNDED AT THE TERMINAL PROVIDED. FAILURE TO GROUND THE APPLIANCE COULD RESULT IN ELECTROCUTION AND DEATH.	
WARNING	INSTALLATION OF THE UNIT MUST BE DONE BY PERSONNEL QUALIFIED TO WORK WITH ELECTRICITY AND PLUMBING. IMPROPER INSTALLATION CAN CAUSE INJURY TO PERSONNEL AND/OR DAMAGE TO EQUIPMENT. UNIT MUST BE INSTALLED IN ACCORDANCE WITH ALL APPLICABLE CODES.	
NOTICE	The data plate is located on the serial tag, which is riveted to the front of the unit in the lower right hand corner. The range voltage, wattage, serial number, wire size, and clearance specifications are on the data plate. This information should be carefully read and understood before proceeding with the installation.	
NOTICE	The installation of any components such as a vent hood, grease extractors, fire extinguisher systems, must conform to their applicable National, State and locally recognized installation standards.	
CAUTION	MAKE SURE THE SIX WIRE LEADS TO SUPPLY ELECTRICITY TO THE COOK TOP ARE NOT CRIMPED BETWEEN THE OVEN AND RANGE TOP.	
WARNING	MAKE SURE THE MAIN POWER SUPPLY TO THE RANGE IS TURNED OFF AT THE SOURCE PRIOR TO CONNECTING POWER TO THE RANGE.	
CAUTION	BE SURE THE POWER SUPPLY VOLTAGE MATCHES THE VOLTAGE SPECIFIED ON THE NAME-PLATE LOCATED ON THE FRONT OF THE RANGE.	
NOTICE	During the first few hours of operation you may notice a small amount of smoke coming off the range, or out of the oven, and a faint odor from the smoke. This is normal for a new range and will disappear after the first few hours of use.	
CAUTION	ALWAYS KEEP THE AREA NEAR THE APPLIANCE FREE FROM COMBUSTIBLE MATERIALS.	
CAUTION	KEEP FLOOR IN FRONT OF EQUIPMENT CLEAN AND DRY. IF SPILLS OCCUR, CLEAN IMMEDIATELY, TO AVOID THE DANGER OF SLIPS OR FALLS.	
WARNING	KEEP WATER AND SOLUTIONS OUT OF CONTROLS. NEVER SPRAY OR HOSE CONTROL CONSOLE, ELECTRICAL CONNECTIONS, ETC.	

CAUTION MOST CLEANERS ARE HARMFUL TO THE SKIN, EYES, MUCOUS MEMBRANES AND CLOTHING. PRECAUTIONS SHOULD BE TAKEN TO WEAR RUBBER GLOVES, GOGGLES OR FACE SHIELD AND PROTECTIVE CLOTHING. CAREFULLY READ THE WARNING AND FOLLOW THE DIRECTIONS ON THE LABEL OF THE CLEANER TO BE USED.



NOTICE Service on this, or any other, LANG appliance must be performed by qualified personnel only. Consult your LANG authorized service station directory or call the factory at 1-800-807-9054, or WWW.STAR-MFG.COM For the service agent nearest you.



WARNING BOTH HIGH AND LOW VOLTAGES ARE PRESENT INSIDE THIS APPLIANCE WHEN THE UNIT IS PLUGGED/WIRED INTO A LIVE RECEPTACLE. BEFORE REPLACING ANY PARTS, DISCONNECT THE UNIT FROM THE ELECTRIC POWER SUPPLY.



CAUTION USE OF ANY REPLACEMENT PARTS OTHER THAN THOSE SUPPLIED BY LANG OR THEIR AUTHORIZED DISTRIBUTORS CAN CAUSE BODILY INJURY TO THE OPERATOR AND DAMAGE TO THE EQUIPMENT AND WILL VOID ALL WARRANTIES.



WARNING MAKE SURE THE RANGE HAS BEEN PROPERLY SECURED FROM POWER BEFORE REMOVING ANY COMPONENTS.



LANG MANUFACTURING COMPANY
MANUAL FOR MODEL 9D-RT36A-440VG (ALSO KNOWN AS RF21SM-A)
ELECTRIC CONVECTION OVEN RANGE

ISSUED DATE: JULY 2001

LANG MANUFACTURING COMPANY
6500 MERRILL CREEK PARKWAY
EVERETT, WA 98203

ELECTRIC CONVECTION OVEN RANGE PER: MIL-X-XXXXXXXX

MIL SPEC	LANG MODEL NUMBER	SPECIFIC NSN
MIL-R-43954	RF21SM-A	7310-01-104-3349

* N.S.A. FOR "NAVAL SHIPBOARD APPLICATION". ALL COMPONENTS WILL FIT THROUGH A 26" WATERTIGHT HATCH.

SPECIFICATION SHEET



MarineSeries

Item No. _____
 Project _____
 Quantity _____

36" Electric Range With Convection Oven

Model: RF21SM-__



Model RF21SM-A shown

MARINE SHORT/BID SPECIFICATION

Range shall be a **LANG Manufacturing Marine Model RF21SM-__** [Specify one]:

- A, with 1ea. 24" X 24" X 1/2" thick Griddle and 2 ea. 8" diameter French Plates;
- C, with 3 ea. 12" X 24" X 3/4" thick Hot Plates;
- D, with 2 ea. 12" X 24" X 3/4" thick Hot Plates and 2 ea. 8" diameter French Plates;
- G, with 36" X 24" X 1/2" thick Griddle;
- G-SUB, with 36" X 24" X 1/2" thick Griddle, plus [Submarine Spec]; or
- H, with 6 ea. 8" diameter French Plates

...a 36" wide heavy duty electric heated unit with convection oven base and 21.6-kW total power input; hatchable two piece construction with all stainless steel exterior; large capacity fully insulated oven with six sheet pan capacity, powerful blower, aluminized steel interior, heavy duty side hinged with latch and three oven racks standard; individual oven and cook-top component controls; Sea rails and stainless steel front grab bar.

MARINE PRODUCT WARRANTY

One year, parts & labor (Labor in U.S. only)

MARINE CONSTRUCTION FEATURES

- Two piece modular construction
- Heavy duty 430 Series stainless steel exterior, with attractive No. 4 finish
- 17" high cooking compartment is aluminized steel
- Submarine Spec [-G-SUB] model includes stainless steel oven compartment & door liner
- 3" insulation on six sides of cooking compartment
- Right side mounted blower with 1/3 HP motor
- Incoloy sheathed oven heating elements
- Heavy duty oven door hinged-left, with positive latch
- Six position oven rack slide supports
- Three oven racks provided
- Sea rails and full width front mounted grab bar
- 2-3/4" wide full width front grease trough
- Grease drain in trough with full width & depth spillage drawers
- Griddle top configurations include one piece welded splash guard back & sides
- 6" adjustable legs w/ bolt-down flange standard

PERFORMANCE FEATURES

- Multi-function 36" wide unit fits into most marine galleys
- Hatchable two-piece design allows movement through 26" X 66" watertight hatch
- Choice of six cook-top configurations, to include:
 - 24" wide, 1/2" thick Griddle & 2 ea. 8" diameter French Plates
 - 3 ea. 12" wide Hot Plates
 - 2 ea. 12" wide Hot Plates & 2 ea. 8" diameter French Plates
 - 36" wide, 1/2" thick Griddle
 - 6 ea. 8" diameter French Plates
- Large 20" X 24" X 17" high oven holds up to six 18 X 26" sheet pans
- Full front grease trough, grease drain & spillage drawers speed range cleanup
- Separate, independent controls allows precise multi-function cooking

CONTROLS [Varies By Top Configuration]

- Oven power-ON switch
- 150-450°F oven thermostat
- Damper control
- 60 minute timer with alarm
- [-A] Two 450°F thermostats, one per 12" of Griddle plate & two 6-heat level switches [French Plates]
- [-C] Three individual 850°F thermostats [Hot Tops]
- [-D] Two 850°F thermostats [Hot Tops] & two 6-heat level switches [French Plates]
- [-G & -G-SUB] Three 450°F thermostats, one per 12" of Griddle plate
- [-H] Six 6-heat level switches [French Plates]



Sheet No. **LMSP-R4** (rev. 10/04)

LANG MANUFACTURING COMPANY • 6500 Merrill Creek Parkway, Everett, WA 98203
 TOLL FREE: 800.882.6368 • FAX: 425.349.2733 • www.langworld.com

SPECIFICATION SHEET



36" Electric Range With Convection Oven

Model: RF21SM-__

CONFIGURATION GUIDE

Model Has:	RF21M-A	RF21M-C	RF21M-D	RF21M-G RF21M-G-SUB	RF21M-H
Oven Base:	Convection*	Convection*	Convection*	Convection*	Convection*
Griddle:	24" wide	-	-	36" wide	-
French Plates:	2 each	-	2 each	-	6 each
Hot Plates:	-	3 each	2 each	-	-
Pictogram: [Unit Top View]					

* 6 each, 18" x 26" sheet pan capacity

MARINE INSTALLATION REQUIREMENTS

- Single 208V or 240V, 1/3-Phase; or optional 440V/480V, 3-phase electrical connection
- Installation under approved vent hood required. Consult marine codes. [Power connection from bottom. See below]

MARINE OPTIONS & ACCESSORIES

- 440V/480V, 3-phase model
- Substitute 1" thick griddle plate for grooving [12" wide]
- Substitute 1" thick griddle plate for grooving [24" wide]
- Substitute 1" thick griddle plate for grooving [36" wide]
- Grooving on [1" thick ONLY] Griddle Plate [per foot]
- Stainless steel oven interior [Standard on -G-SUB Model]
- Stainless steel curb mounting flange [Order in place of legs]
- Extra wire pan rack [Three provided as std.]
- Lang Clamshell" Hood 24" wide [Must order w/1" griddle plate]
- Split Voltage - To connect 208/1 or 240/1 Clamshell to 440V/480V range
- MIL-SPEC Adder Package [Meets: MIL-R-43954A Grade B]:
 - Stainless steel oven liner
 - Oven door de-energizer switch
 - 6 pan racks
 - External metal serial number tag

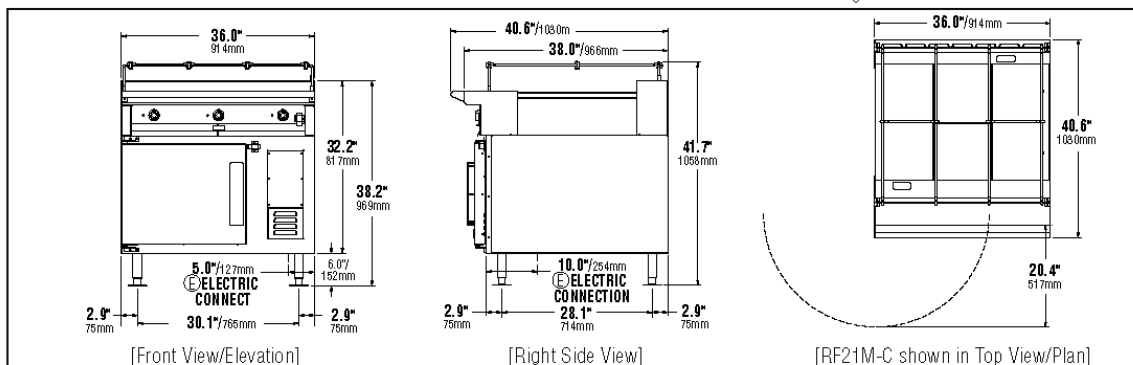

Model	Height x Width x Depth (With standard legs)	Clearance from combustible surface	Weight		Freight Class
			Actual	Shipping	
RF21SM	41.7" x 36.0" x 40.6" 1053mm x 914mm x 1030mm	Sides: 4" (100mm) Back: 4" (100mm)	425-520* lbs. 193-236 kg	475-570* lbs. 216-259 kg	85

* Depending on configuration.

Model	Volts AC - Hz	Total kW	Amps - Three Phase	Amps - Single Phase
RF21SM	208 - 50/60	21.6	69.2	103.8
	240 - 50/60	21.6	59.9	90.0
	440 - 50/60	18.1	28.2	N/A
	480 - 50/60	21.6	29.5	N/A

Due to continuous improvements, specifications subject to change without notice.



Sheet No. LMSP-R4 (rev. 10/04)

LANG MANUFACTURING COMPANY • 6500 Merrill Creek Parkway, Everett, WA 98203
TOLL FREE: 800.882.6368 • FAX: 425.349.2733 • www.langworld.com

EQUIPMENT DESCRIPTION

ELECTRIC RANGE EXTERIOR

- The Range dimensions are 30" (76.2cm) High (without legs), 38" (96.5cm) Deep, and 36" (91.5cm) Wide.
- The Sides, Bottom, and Rear wall are constructed stainless steel.
- The Range surface comes with a 24" griddle and two 9" in diameter French Plates.

ITEMS

- 1 ea. 9P-RT36A-440VG (Range Top) RF21-AM-U
- 1 ea. 9Q-FCOFL-AT440G (Convection Oven) F-6S-M-U
- 4 ea. Bolt down legs
- 2 ea. Operation Manuals
- 1 ea. Marine Handle
 - 4 ea. 1/4-20x1/2" HXD bolt S/S.
 - 4 ea. Lock Washer, S/S

RANGE TOP CONTROLS

The RT36A (also known as RF21SM-A) Series Range comes with one 24"x24" Griddle that has a temperature range of 100°F -450°F and two French Plates that have a temperature range of 200°F-750°F. Each section of the grill is controlled by a 450°F thermostat and each French Plate is controlled by a 6-heat switch. In addition the range comes with a convection oven that is controlled by one thermostat that has a temperature range of 150°F-450°F. Below is a layout of the top configuration.

RT36A (RF21SM-A)

One 24"x24" Griddle controlled by two 450°F thermostats and two French Plates controlled by two 6-heat switches.

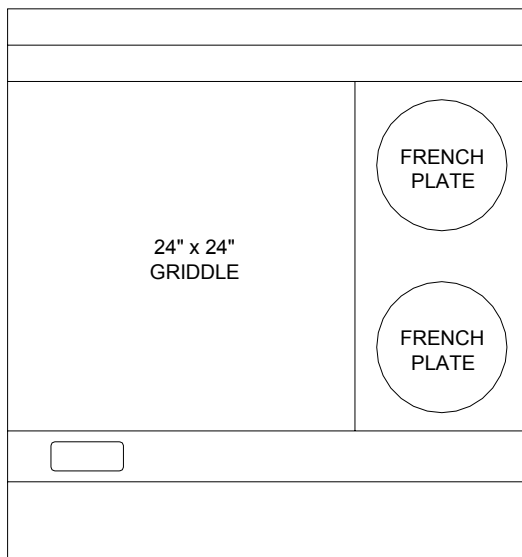

RANGE TOP CONFIGURATION

UNPACK-ING

- CAUTION** EACH UNIT WEIGHS 600 LBS (THE TOP WEIGHS 410 LBS). FOR SAFE HANDLING, INSTALLER SHOULD OBTAIN HELP AS NEEDED, OR EMPLOY APPROPRIATE MATERIALS HANDLING EQUIPMENT (SUCH AS A FORKLIFT, DOLLY, OR PALLET JACK) TO REMOVE THE UNIT FROM THE SKID AND MOVE IT TO THE PLACE OF INSTALLATION.
- CAUTION** ANY STAND, COUNTER OR OTHER DEVICE ON WHICH RANGE WILL BE LOCATED MUST BE DESIGNED TO SUPPORT THE WEIGHT OF THE RANGE.
- CAUTION** SHIPPING STRAPS ARE UNDER TENSION AND CAN SNAP BACK WHEN CUT.



RECEIVING THE OVEN

Upon receipt, check for freight damage, both visible and concealed. Visible damage should be noted on the freight bill at the time of delivery and signed by the carrier's agent. Concealed loss or damage means loss or damage, which does not become apparent until the merchandise has been unpacked. If concealed loss or damage is discovered upon unpacking, make a written request for inspection by the carrier's agent within 15 days of delivery. All packing material should be kept for inspection. Do not return damaged merchandise to Lang Manufacturing Company. File your claim with the carrier.

LOCATION

Prior to un-crating, move the range as near its intended location as practical. The crating will help protect the unit from the physical damage normally associated with moving it through hallways and doorways.

UN-CRATING

The range will arrive in two packages, each inside a wood frame covered by cardboard box and strapped to a skid. **Remove the cardboard cover, cut the straps and remove the wood frame.** The oven may now be removed from the skid.

INSTALLING THE LEGS

To install the legs, place some cardboard on the floor and gently tip the oven portion of the range onto its back. A 1/2-13 threaded weld nut is provided in each of the four corners of the oven. Thread each leg into the threaded weld nuts and lift oven back onto the legs. (See leg layout below).

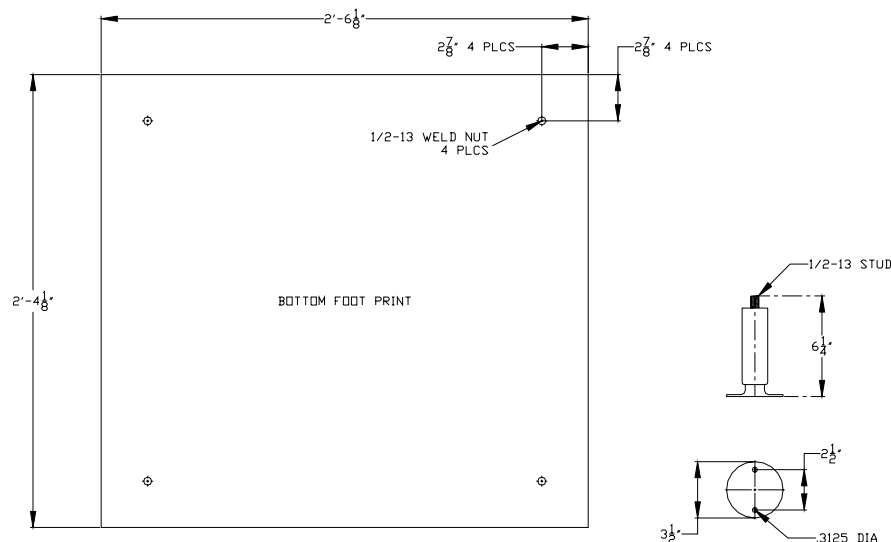

INSTALLATION

DANGER THIS APPLIANCE MUST BE GROUNDED AT THE TERMINAL PROVIDED. FAILURE TO GROUND THE APPLIANCE COULD RESULT IN ELECTROCUTION AND DEATH.



WARNING INSTALLATION OF THE UNIT MUST BE DONE BY PERSONNEL QUALIFIED TO WORK WITH ELECTRICITY AND PLUMBING. IMPROPER INSTALLATION CAN CAUSE INJURY TO PERSONNEL AND/OR DAMAGE TO EQUIPMENT. UNIT MUST BE INSTALLED IN ACCORDANCE WITH ALL APPLICABLE CODES.



NOTICE The data plate is located on the serial tag, which is riveted to the front of the unit in the lower right hand corner. The range voltage, wattage, serial number, wire size, and clearance specifications are on the data plate. This information should be carefully read and understood before proceeding with the installation.



NOTICE The installation of any components such as a vent hood, grease extractors, fire extinguisher systems, must conform to their applicable National, State and locally recognized installation standards.



ELECTRICAL CONNECTION

A 1¼” knockout is provided on the bottom left hand side of the oven below the control panel for power connection.

The electrical connection must be made in accordance with local codes or in the absence of local codes with **National Electrical Code** latest edition (in Canada use: **CSA STD. C22.1**).

Place spacers, (ie. 2 x 4 wood block not supplied) at the front and rear of the oven top.

Place the range top on the spacers (ie. 2 x 4 wood block not supplied) that are located on top of the oven.

The six wire leads to supply electricity to the cook top are bundled under the front bottom of the top. Route these wires through the bushing provided in the oven top.

Align the four locating pins at the bottom corners of the Range bottom with the four holes in each corner of the oven top.

Remove the spacers and lower the Range onto the oven.

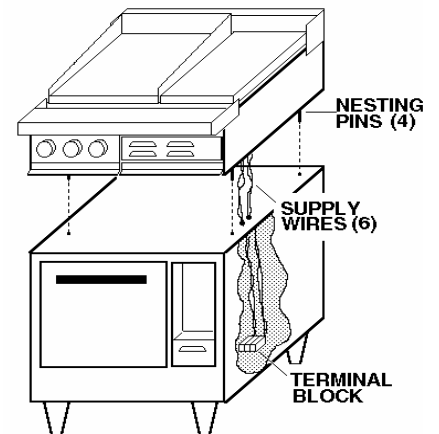

CAUTION MAKE SURE THE SIX WIRE LEADS TO SUPPLY ELECTRICITY TO THE COOK TOP ARE NOT CRIMPED BETWEEN THE OVEN AND RANGE TOP.



WARNING MAKE SURE THE MAIN POWER SUPPLY TO THE RANGE IS TURNED OFF AT THE SOURCE PRIOR TO CONNECTING POWER TO THE RANGE.



The range can now be connected to power.

CAUTION BE SURE THE POWER SUPPLY VOLTAGE MATCHES THE VOLTAGE SPECIFIED ON THE NAMEPLATE LOCATED ON THE FRONT OF THE RANGE.



Use the wiring diagram provided in this manual for determining the connections of the cook top wires to the oven terminal block.

INITIAL START-UP

INITIAL PREHEAT

Prior to putting any range or oven into full time operation at normal cooking temperatures, it must be thoroughly dried out. Moisture absorption in the closed spaces, in the insulation, and even inside the heating elements can cause future trouble if not properly treated.

Griddles

To “dry out” the griddle, set the thermostat to 250°F. Allow the unit to operate at least 15 minutes at this heat level. Set the thermostat to 350°F and allow another 15 minutes to elapse. Set the thermostat to 450°F and allow the unit to maintain the temperature for a minimum of 4 hours. More time may be required if the unit has to operate in a moist environment.

If the unit is out of use for three or more days, a one-hour preheat schedule should be used, especially when exposed to high humidity and/or cool temperatures.

Before any griddle plate can be put into full operation it will need to be properly seasoned. To do this, turn the griddle to 200°F and wait for the red heat indicator lamp to shut off. Once the indicator lamp has shut off, apply a thin coat of high-grade, non-salted vegetable oil to the griddle surface with a metal spatula or towel. Wait approximately five minutes and re-coat any dry spots. Repeat this procedure at 300°F and at 400°F.

French Plates

To “dry out” the French plates, set the 6-heat switch to position three. Allow the unit to operate at least 15 minutes at this heat level. Set the 6-heat switch to position four and allow another 15 minutes to elapse. Set the 6-heat to position six and allow the unit to maintain the temperature for a minimum of 4 hours. More time may be required if the unit has to operate in a moist environment.

If the unit is out of use for three or more days, a one-hour preheat schedule should be used, especially when exposed to high humidity and/or cool temperatures.

Ovens

To “dry out” the oven, set the thermostat to 250°F and turn on the power switch. Allow the unit to operate at least 15 minutes at this heat level. Set the thermostat to 350°F and allow another 15 minutes to elapse. Set the thermostat to 450°F and allow the unit to maintain the temperature for a minimum of 4 hours. More time may be required if the unit has to operate in a moist environment.

If the unit is out of use for three or more days, a one-hour preheat schedule should be used, especially when exposed to high humidity and/or cool temperatures.

NOTICE

During the first few hours of operation you may notice a small amount of smoke coming off the range, or out of the oven, and a faint odor from the smoke. This is normal for a new range and will disappear after the first few hours of use.



OVEN

The convection oven roasts and bakes in shorter time and at lower temperatures with less shrinkage than conventional commercial ovens.

A blower in the Lang convection oven circulates air within the chamber to heat the entire space evenly and transfer heat efficiently to the product, even with stacked loading.

The airflow continuously removes the thick layer of moist, cool air that otherwise would surround the product. When properly loaded and operated, it maintains this airflow throughout the chamber to eliminate hot spots and roasts or bakes with minimum power consumption at twice the output capacity of a conventional oven.

The power switch on the lower portion of the control panel energizes the fan motor and activates the thermostatically controlled circuit for the oven heating elements. When this switch is in the on position, the red indicator light will illuminate.

Rotating the thermostat control knob from "off" position to selected temperature causes the indicator light to illuminate and closes the contactor that feeds power to the heating elements. This light will cycle "on and off" as the thermostat calls for heat in the oven. The blower, however, operates continuously while the power switch is in the "on" position.

The black control knob operates a damper in the oven vent stack. The damper is open when knob is pulled outward.

Circuit breakers behind the control panel protect the electrical components from overload.

Griddle

Thermostats control 24" x 24" grill plate.

Temperature ranges from 100°-450°F.

Recommended: All heavy and light frying.

Set the thermostat dial at the desired temperature and allow for a thirty-minute preheat time.

The red indicator light will be on until the desired temperature is reached and then shut off.

The pilot light will cycle on and off as the elements cycle on and off.

French Plate

6-heat switch controls one, French Plate.

Temperature settings range from 1(low) to 6(high).

Recommended: Light duty sauce pans and small stockpots.

Not Recommended: Heavy stock pots, or heavy urns, or kettles.

Set the 6-heat dial to the desired setting and allow for a thirty-minute preheat time.

MAINTENANCE & CLEANING

CAUTION	ALWAYS KEEP THE AREA NEAR THE APPLIANCE FREE FROM COMBUSTIBLE MATERIALS.
CAUTION	KEEP FLOOR IN FRONT OF EQUIPMENT CLEAN AND DRY. IF SPILLS OCCUR, CLEAN IMMEDIATELY, TO AVOID THE DANGER OF SLIPS OR FALLS.
WARNING	KEEP WATER AND SOLUTIONS OUT OF CONTROLS. NEVER SPRAY OR HOSE CONTROL CONSOLE, ELECTRICAL CONNECTIONS, ETC.
CAUTION	MOST CLEANERS ARE HARMFUL TO THE SKIN, EYES, MUCOUS MEMBRANES AND CLOTHING. PRECAUTIONS SHOULD BE TAKEN TO WEAR RUBBER GLOVES, GOGGLES OR FACE SHIELD AND PROTECTIVE CLOTHING. CAREFULLY READ THE WARNING AND FOLLOW THE DIRECTIONS ON THE LABEL OF THE CLEANER TO BE USED.



CLEANING

- Always start with a cold range.
- The stainless exterior can easily be cleaned using Lang Mfg. Prime Shine (72804-41) oven cleaner.
- Always follow the cleaner manufacturer's instructions when using any cleaner.
- Care should be taken to prevent caustic cleaning compounds from coming in contact with the aluminized blower wheel and aluminized inside of the oven.
- Discoloration or heat tint may be removed using Lang Mfg. Carbon Release (72804-32) oven cleaner.

Always apply these cleaners when the oven is cold and rub in the direction of the metal's grain

The range should be thoroughly cleaned at least once a week in addition to the normal daily cleaning to insure against the accumulation of foreign material.

Keep drip pans under range top plates clean.

Keep hot plate and french plate surfaces clean.

Outside of range and top should be kept clean.

Electric equipment is inherently clean and sanitary, but may become unsanitary if grease is allowed to accumulate on it. Take advantage of the clean, sanitary features of electric equipment, give it the regular attention that it deserves the same as any other highly perfected machinery, to insure best results and continued high operating efficiency.

EMERGENCY LOCKOUT

Locate power disconnect at source and remove power from range.

LONG TERM STORAGE

Secure range from power.

Apply a generous amount of Lang Mfg. Prima Shine (72804-41) to the stainless steel.

Apply a generous amount of Lang Mfg. Shipping Preservative Grease (72804-08) to the hop plate surface and the French plate surface.

MAINTENANCE & CLEANING

NOTICE

Service on this, or any other, LANG appliance must be performed by qualified personnel only. Consult your authorized service station directory or call the factory at 1-800-224-LANG (5264), or WWW.LANGWORLD.COM For the service station nearest you.



WARNING

BOTH HIGH AND LOW VOLTAGES ARE PRESENT INSIDE THIS APPLIANCE WHEN THE UNIT IS PLUGGED/WIRED INTO A LIVE RECEPTACLE. BEFORE REPLACING ANY PARTS, DISCONNECT THE UNIT FROM THE ELECTRIC POWER SUPPLY.



CAUTION

USE OF ANY REPLACEMENT PARTS OTHER THAN THOSE SUPPLIED BY LANG OR THEIR AUTHORIZED DISTRIBUTORS CAN CAUSE BODILY INJURY TO THE OPERATOR AND DAMAGE TO THE EQUIPMENT AND WILL VOID ALL WARRANTIES.



TROUBLE SHOOTING

OVEN

OVEN WILL NOT HEAT

PROBABLE CAUSE	CORRECTIVE ACTION
Oven circuit breaker not on	Cycle breaker to the "ON" position.
Incorrect wiring	Confirm that oven is getting proper voltage. Confirm that range is phased correctly.
Defective transformer	Confirm that transformer is getting correct voltage. Confirm that transformer is putting out correct voltage.
Defective Fuses	Replace fuses.
Defective Contactor	Confirm that contactor is getting correct voltage on the coil.
Defective Thermostat	Confirm that thermostat is getting correct voltage. Confirm that thermostat is operating properly.
Defective Element	Confirm that element is getting correct voltage Check element for normal operation. (11.5 Amps)

OVEN MOTOR WILL NOT COME ON

PROBABLE CAUSE	CORRECTIVE ACTION
Incorrect wiring	Confirm that oven is getting proper voltage. Confirm that range is phased correctly.
Defective transformer	Confirm that transformer is getting correct voltage. Confirm that transformer is putting out correct voltage.
Defective Fuses	Replace fuses.
Defective Contactor	Confirm that contactor is getting correct voltage on the coil.
Defective Motor	Confirm that motor is getting power and working properly. Replace Motor.

MAINTENANCE & CLEANING

RANGE

Griddle

GRIDDLE WILL NOT HEAT

PROBABLE CAUSE	CORRECTIVE ACTION
Incorrect wiring	Confirm that oven is getting proper voltage. Confirm that range is phased correctly.
Oven circuit breaker not on	Cycle breaker to the "ON" position.
Defective Thermostat	Confirm that thermostat is getting correct voltage. Confirm that thermostat is operating properly.
Defective Element	Confirm that element is getting correct voltage Check element for normal operation (Inside 5.7 Amps, Outside 3.5 Amps).

FRENCH PLATE

FRENCH PLATE WILL NOT HEAT

PROBABLE CAUSE	CORRECTIVE ACTION
Incorrect wiring	Confirm the French Plate is wired correctly. Confirm that range is phased correctly.
Defective 6-Heat switch	Confirm that switch is wired correctly. Confirm that switch is operating correctly.
Defective French Plate	Confirm that French Plate is getting correct voltage. Confirm that French Plate is operating correctly. (See Technical Data)

CALIBRATION

Calibration Check

Place thermometer or thermocouple in the center of oven cavity or grill section.

Set thermostat to 350°F.

Allow the oven or grill to preheat for at least half an hour.

Note cycle on temperatures and cycle off temperatures for 3 cycles. (Red indicator light indicates when oven is calling for heat)

After 3 cycles average the temperature, (Add all six temperatures and divide by 6) The temperature should be +/- 15°F.

Calibration Adjustment

A 1/16" flat blade screwdriver with a 2" shaft is required to make adjustments on the thermostat.

Maintain the oven temperature at 350°F.

Without turning the thermostat, remove the knob.

Locate the adjustment screw at the base of the shaft and insert the screwdriver.

Grasp the shaft and turn the screw. Counter clockwise to increase and clockwise to decrease (1/8 of a turn will move the temperature 5-7 °F in either direction).

Reinstall the oven knob and recheck the oven temperature.

WARNING

MAKE SURE THE RANGE HAS BEEN PROPERLY SECURED FROM POWER BEFORE REMOVING ANY COMPONENTS.



REMOVAL INSTRUCTIONS

OVEN

Thermostat, Contactor, Transformer, and Switch

These parts are located behind the control panel assembly on the right hand side of the oven. To access control panel, remove the vent knob and the seven screws around the outside of the control panel assembly. Slowly pull the control panel toward you until the component is accessible.

Thermostat

Inside the oven, remove the fan baffle and the retaining clips holding the thermostat capillary tube to the inside of the oven. Feed the bulb through the oven wall into the control panel area. Pull out control panel as previously outlined. Remove knob and two screws that hold the thermostat to the oven control panel. Remove the wires from the old thermostat and attach to the corresponding terminal of the new thermostat. Discard old thermostat. Reinstall the thermostat and capillary tube into oven and the control panel and restore power to the oven. Test for proper operation.

Contactor and Switch

Pull out control panel as previously outlined. Remove the wires from the contactor or switch being changed. Place those wires on the corresponding terminal of the new contactor or switch. Remove old contactor or switch and mount new contactor or switch with wires attached. Discard old contactor or switch. Reinstall the control panel and restore power to the oven. Test for proper operation.

Transformer

Pull out control panel as previously outlined. Remove the wires from the old transformer. Place the wires on the corresponding terminal of the new transformer. Remove old transformer and mount new transformer with wires attached. Discard old transformer. Reinstall the control panel and restore power to the oven. Test for proper operation.

Blower Wheel

Inside the oven, remove the racks and right hand rack slide. Remove wing nut holding oven baffle. Remove oven baffle exposing the blower wheel. Loosen the two 1/4-20-set screws holding the blower wheel to the motor shaft. Using a three-fingered wheel puller, grasp the puller ring with all three fingers and tighten the puller until the blower wheel hub clears the motor shaft. Place new blower-wheel on the motor shaft and position the new blower wheel so that it is flush with front inlet ring. Tighten the set-screw over the flat spot on the motor shaft and spin the blower wheel to confirm that blower wheel is strait. Adjust if necessary and tighten second set screw. Test for proper operation.

Motor

Remove the blower wheel as outlined above. Once blower wheel is removed, remove the six bolts holding the motor plate to the side wall of the oven. Gently pull the motor out and lay on the bottom of the oven cavity. Note each wire location on the motor and remove the wires. Remove motor from cavity and remove old motor from motor mounting plate. Attach new motor to motor mounting plate. Reverse removal instructions to assemble. Discard old motor and test for proper operation.

MAINTENANCE & CLEANING

REMOVAL INSTRUCTIONS

OVEN CONTINUED

Elements

Remove oven racks and right hand rack slide from oven. Remove the wing nuts holding oven baffle to right hand of oven. Remove oven baffle from oven. Remove 4 screws holding oven elements to right hand of oven. Gently pull elements away from right hand of oven. Noting wire locations, disconnect wires from element. Discard old element. Reverse removal instructions to assemble.

RANGE TOP

Thermostat

Secure range top from power. Open front control panel and feed capillary tube up towards grill plate. Using two 9" braces, lift the griddle plate up and secure with the two 9" braces. Remove capillary tube holders from the center of the element pan assembly and gently remove from griddle area. Remove two sheet metal screws holding control panel to range top and remove control panel. Remove the thermostat knob and two screws holding the thermostat to the control panel. Discard old thermostat. Reverse removal instructions to install new thermostat.

Elements

Secure range top from power. Using two 9" braces, lift the griddle plate up and secure with the two 9" braces. Remove capillary tube holders from the center of the element pan assembly and gently remove from griddle area. Remove wires from element terminals, noting the wire locations. Remove the five nuts holding the element pan assembly to the bottom of the griddle. Remove defective element from the element pan and discard defective element. To install reverse removal instructions.

6-Heat Switch

Secure range top from power. Remove two sheet metal screws holding control panel to range top and remove control panel. Remove the 6-heat switch knob and two screws holding the 6-heat switch to the control panel. Remove wires from the 6-heat switch terminals noting the wire locations. Discard old 6-heat switch. Reverse removal instructions.

French Plate

Secure range top from power. Using two 9" braces, lift the French plate frame assembly up and secure with the two 9" braces. Remove wires from the element terminals, noting the wire locations. Remove defective French plate assembly from the range. To install reverse removal instructions.

ILLUSTRATED PART BREAKDOWN

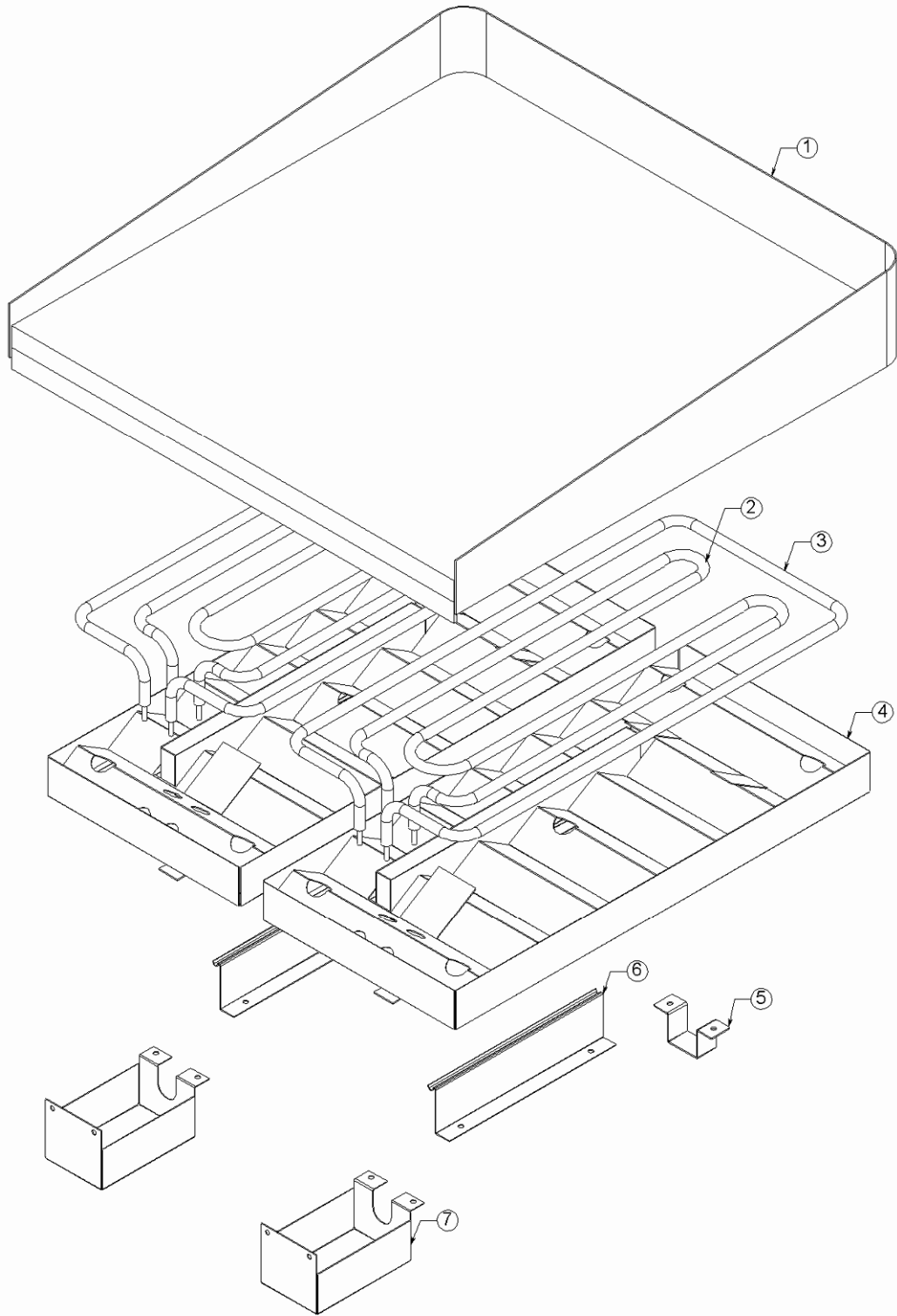

ILLUSTRATED PARTS BREAKDOWN

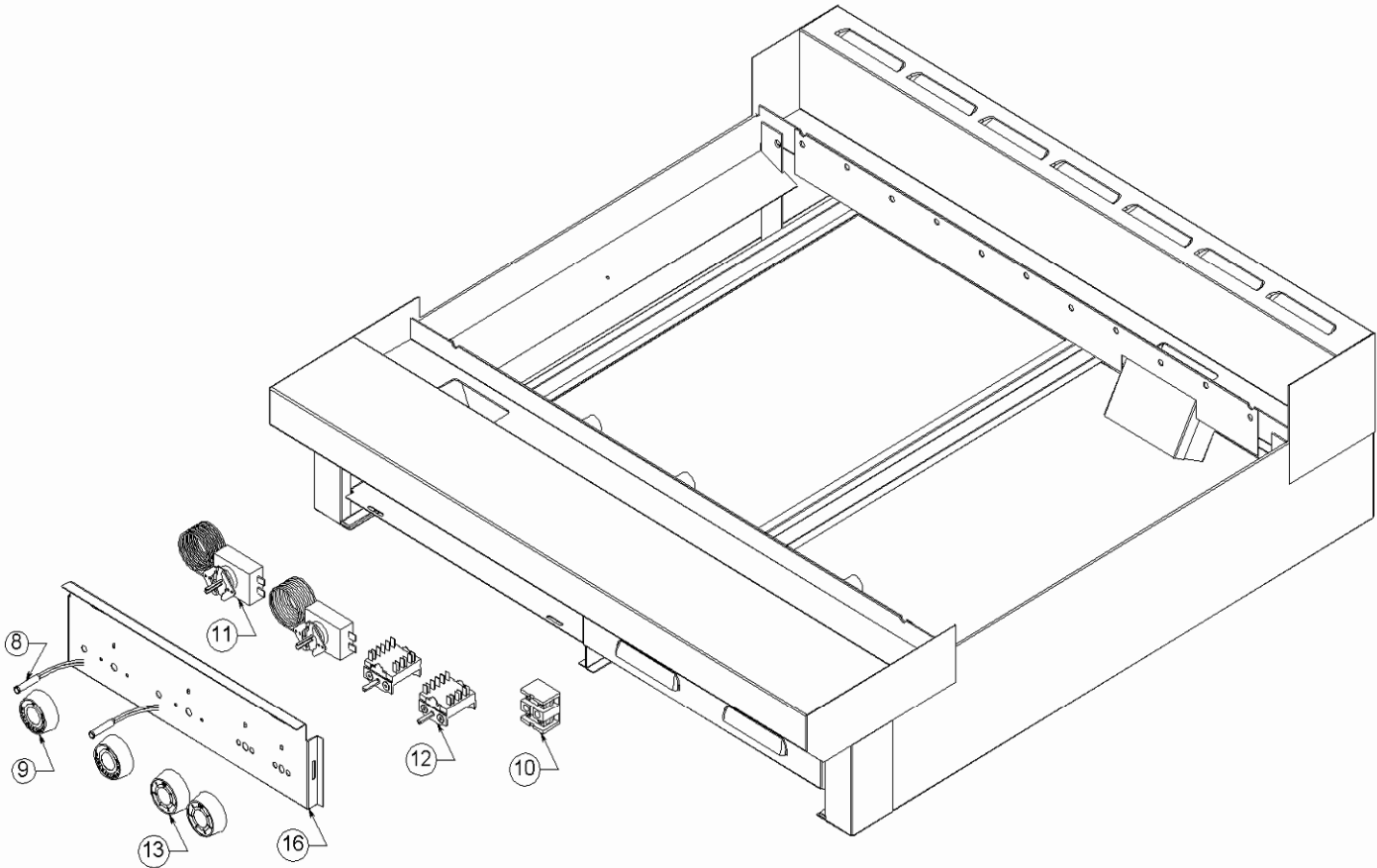

ILLUSTRATED PARTS BREAKDOWN

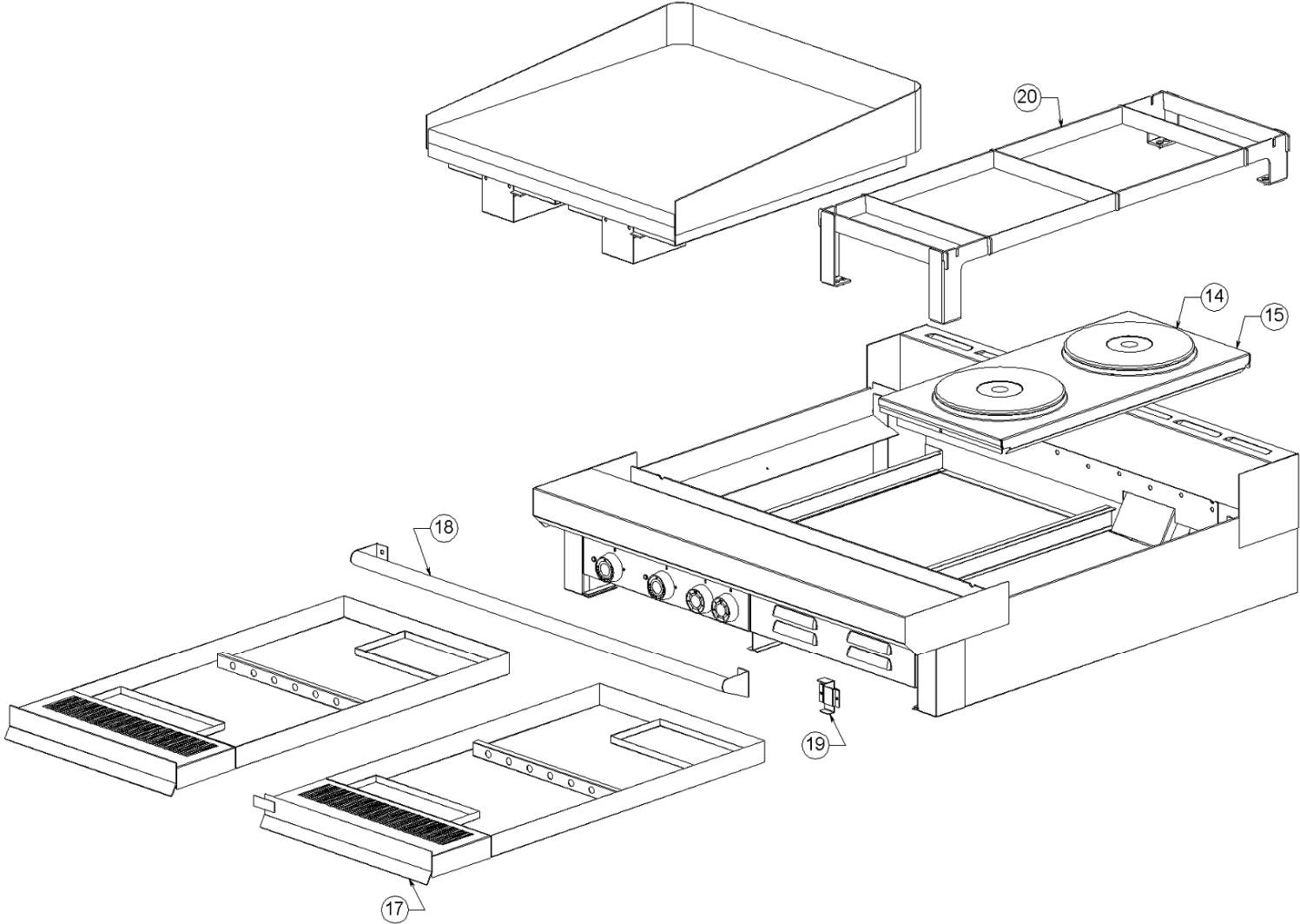

ILLUSTRATED PARTS BREAKDOWN

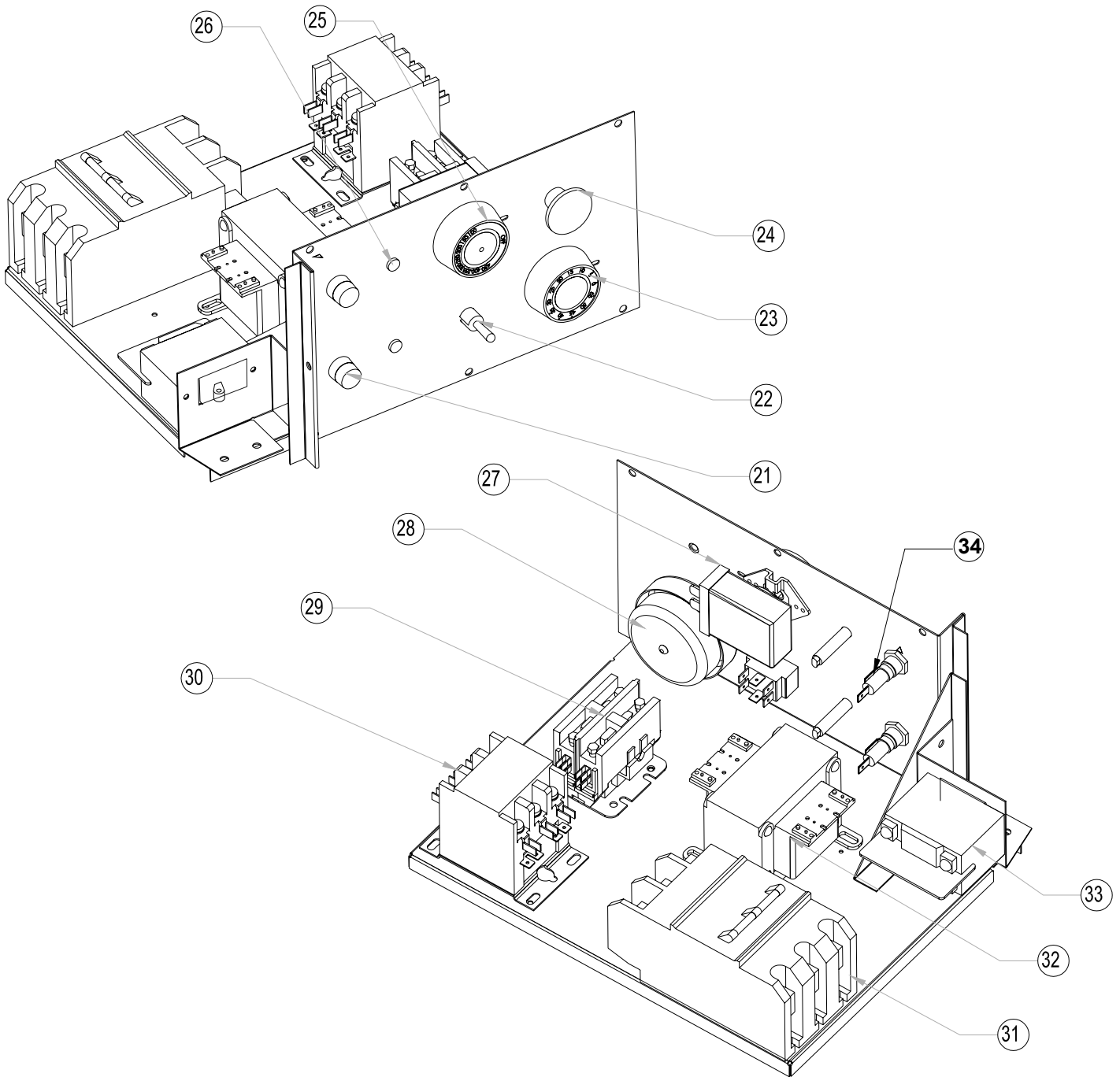

ILLUSTRATED PARTS BREAKDOWN

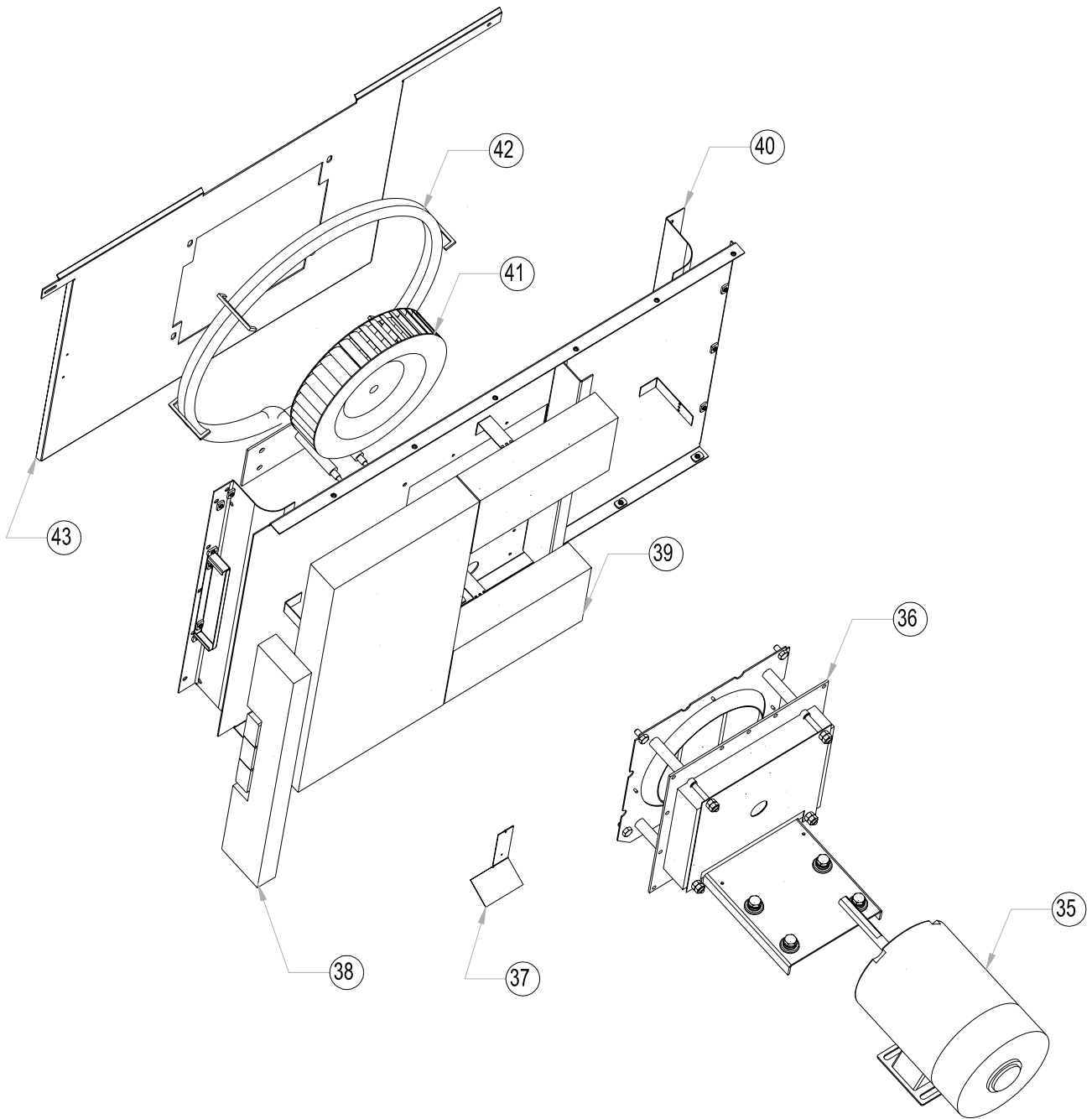

ILLUSTRATED PARTS BREAKDOWN

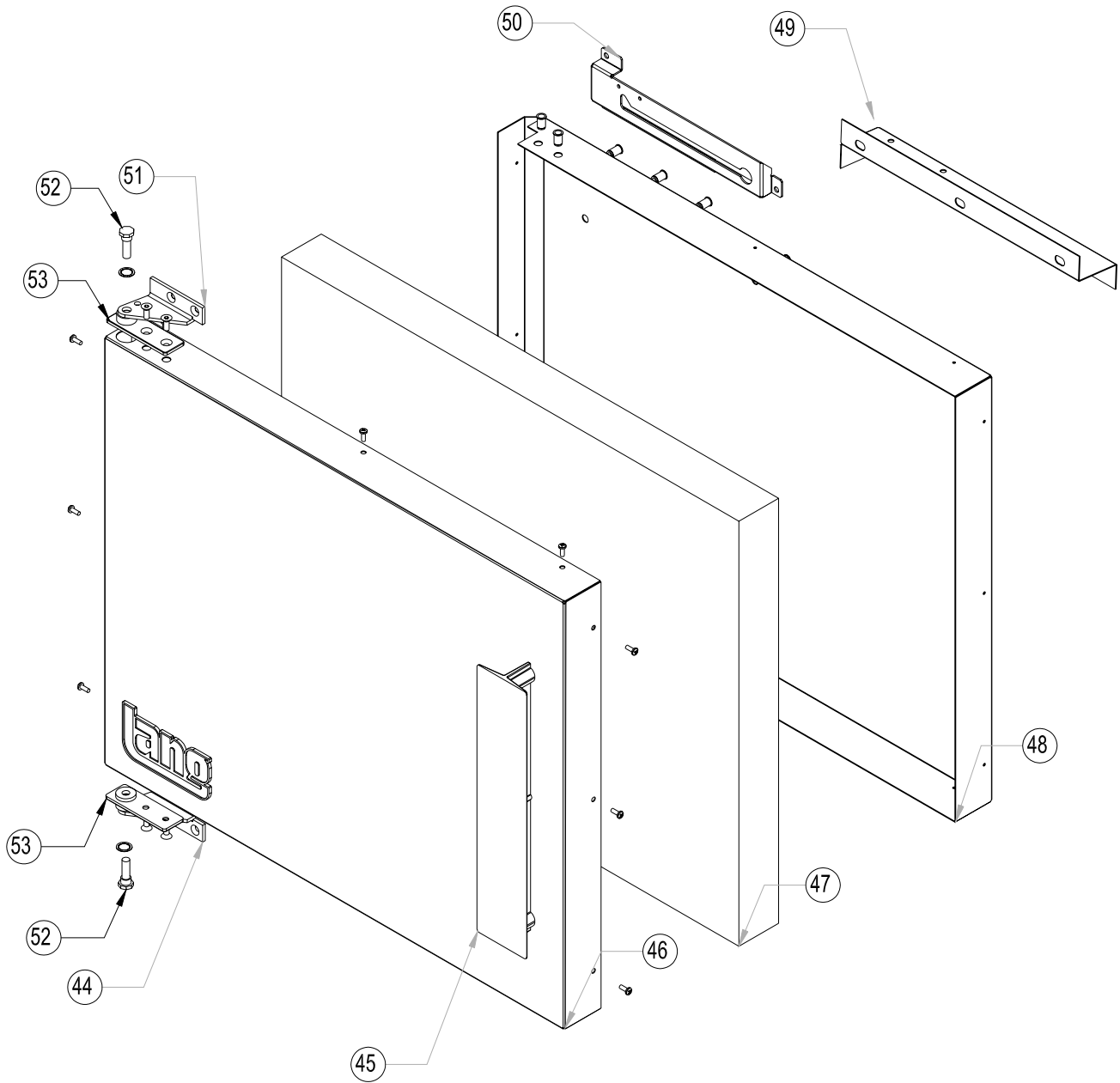

PARTS LIST

Item #	Description	Lang Part #	Vendor	Vendor #
	Range Plate Assembly 1/2" x 3ft	50401-03	Lang Mfg.	50401-03
	Element (Griddle) 440V I/S 3000 Watts	11010-24	Caloritech	1x1-11216-02
	Element (Griddle) 440V O/S 2000 Watts	11010-23	Caloritech	1x1-11217-02
	Element Pan Assembly w/ Snout	50300-20	Lang Mfg.	50300-20
	Wire Bracket	50306-25	Lang Mfg.	50306-25
	Thermostat Capillary Tube Holder	60102-17	Lang Mfg.	60102-17
	Element Terminal Guard	50306-33	Lang Mfg.	50306-33
	Indicator Light 440V	31601-02	Wes-Grade	1854-1-20-20310
	Knob Thermostat 450°F Griddle	70701-16	Lang Mfg.	70701-16
	Terminal Block 3 Pole	30500-07	All-West Fasteners	162-04-3L
	Thermostat 450°F Griddle	30402-08	Invensys	SP-173-72
	French Plate Assembly, 480V, 2600 Watt	11120-14	E.G.O. Products	12.22454.484
	6-Heat Switch	30304-09	E.G.O. Products	49.27214.500
	Thermostat 850°F	30402-23	Invensys	KNP-5-48
	French Plate Frame Assembly	50300-82	Lang Mfg.	50300-82
	Ship Rail 90° 13"	50900-01	Lang Mfg.	50900-01
	Ship Rail Hooked 11 $\frac{5}{8}$ "	50901-01	Lang Mfg.	50901-01
	Ship Rail Hooked 32 $\frac{1}{4}$ "	50901-04	Lang Mfg.	50901-04
	Ship Rail Socket	50902-03	Lang Mfg.	50902-03
	Ship Rail Socket	50902-05	Lang Mfg.	50902-05
	Knob 6-heat switch	70701-41	Lang Mfg.	70701-41
	Range Top Control Panel Front	RF21-306-1	Lang Mfg.	RF21-305-1
	Range Top Front	RF21-711	Lang Mfg.	RF21-711
	Pan / Grease Drawer	RF21-705	Lang Mfg.	RF21-705
	Grab Bar Assembly 36" Long	50300-44	Lang Mfg.	50300-20
	Marine Pan Latch Assembly	60102-93	Lang Mfg.	60102-93
	Range Top Left Hand Assembly	RF21-710	Lang Mfg.	RF21-710
	Range Top Center Channel	RF21-704	Lang Mfg.	RF21-704
	Range Top Right Hand Assembly	RF21-709	Lang Mfg.	RF21-709
	Range Top Rear Assembly	RF21-703	Lang Mfg.	RF21-703
21	Fuse Holder 15 Amp	30901-02	H.D. Campbell	HKP-H-H Bussman
22	Switch Toggle On-Off	30303-06	Carling Tech	2GL231-78-XLN2
23	Knob Manual Timer	70701-09	Lang Mfg	70701-09
24	Knob Damper Black	70701-25	Reid Tool	DK-49-Reid
25	Knob Thermostat 450°F Oven	70701-19	Lang Mfg	70701-19
26	Pilot Light 208/240V	31601-01	Wes-Grade	2152-1-23-20110
27	Thermostat 450°F Oven	30402-27	Invensys	KXP-356-48
28	Timer Mechanical Long Ring	30801-01	M.H. Rhodes	220012
29	Contacto 2 Pole 208/240 VAC	30701-02	Products Unltd	3100-20U3198
30	Contacto 3 Pole 208/240 VAC	30700-05	Products Unltd	3100-30U8198LM
31	Circuit Breaker 440 Volt 3 Pole	31800-04	Carling Tech	EA3X00191832CHB
32	Transformer 440/240 VAC	31400-04	Argo Inter'l	HD/2221109T00
33	Circuit Breaker 440 Volt 2/10 Amp 2 Pole	31800-07	Carling Tech	CB3B02422022CC
34	Fuse 15 Amp	30900-01	H.D. Campbell	ABC-15
35	Motor 1/3 HP 440 Volt	30200-03	Merkle-Korff	101356.00
36	Motor Mount Assembly	F6-188	Lang Mfg.	F6-188
37	Baffle Deflector	F6-123-1	Lang Mfg.	F6-123-1
38	Insulation R/H	F6-158	Lang Mfg.	F6-158
39	Insulation Rear	F6-251	Lang Mfg.	F6-251
40	Can R/H side	F6-104-5	Lang Mfg.	F6-104-5
41	Blower Wheel	71500-03	Revcor Inc	1-7981
42	Element (Oven) 440 Volt 6000 Watts	11090-11	Caloritech	1x1-11090-11
43	Baffle	F6-122-1	Lang Mfg.	F6-122-1
44	Hinge Bracket, Lower Left (Oven)	70601-28	Kason Ind	91510004080035C
45	Door Handle 11 1/2" Long Black	50800-12	Prodeco	50800-12
46	Door Outer Skin	F6-145	Lang Mfg.	F6-145
47	Door Insulation	F6-144-1	Lang Mfg.	F6-144-1
48	Door Inner Skin	F6-144-6	Lang Mfg.	F6-144-6
49	Door Micro switch assembly	60102-1661	Lang Mfg.	60102-1661
50	Door Stop & Slide	50301-50	Lang Mfg.	50301-50
51	Hinge Bracket, Upper Left (Oven)	70601-27	Kason Ind	91511005100035C
52	Hinge Pin	70601-06	Kason Ind	915230005410033F
53	Hinge Plate & Bushing (Door)	70601-05	Kason Ind	9152300050
	Complete Door Assembly	60102-2031	Lang Mfg.	60102-2031

WIRING DIAGRAM

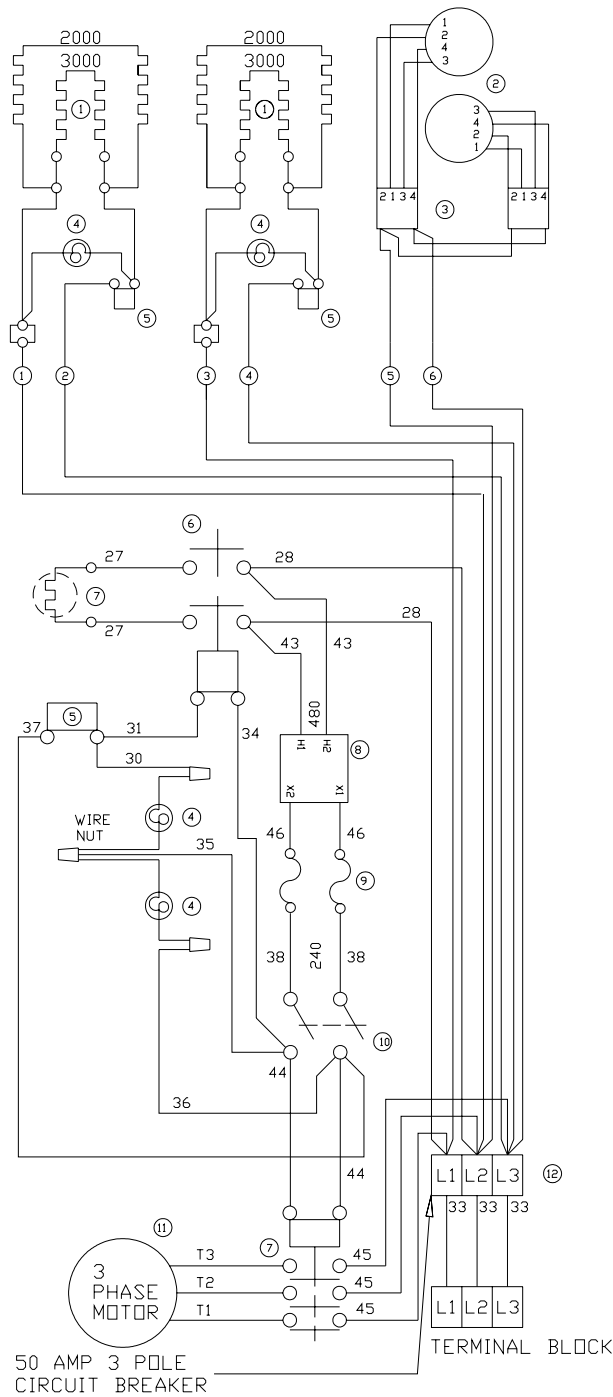

ELECTRICAL CONNECTIONS		
POWER SUPPLY		RANGE TOP CONNECT TO OVEN CIRCUIT BREAKER
THREE PHASE	L1	3
	L2	1-5
	L3	2-4-6

①	GRIDDLE ELEMENTS
②	FRENCH PLATES
③	SIX HEAT SWITCH
④	PILOT LAMP
⑤	THERMOSTAT
⑥	CONTACTOR
⑦	OVEN ELEMENT
⑧	TRANSFORMER
⑨	FUSE
⑩	TOGGLE SWITCH
⑪	MOTOR
⑫	CIRCUIT BREAKER

CAUTION: CHECK OVEN FOR PROPER DIRECTION OF FAN ROTATION
CHANGE PHASING OF POWER IF NECESSARY TO CORRECT

CONNECT WIRE FROM RANGE TOP TO OVEN CIRCUIT BREAKER.

CONVECTION OVEN/RANGE ELECTRICAL DATA								
MODEL NUMBER	LOADING				TOTAL CONN. LOAD	AMPS THREE PHASE		
	KW/PHASE					L1	L2	L3
RF21SM-A	L1	L2	L3	L3	L1	L1	L2	L3
480-VOLT	6.2	10.2	5.2	21.6	20.1	29.5	27.7	
440-VOLT	5.2	8.6	4.4	18.1	16.9	24.8	23.3	

Lang Manufacturing Limited Warranty to Commercial Purchasers* (Contiguous U.S. Including Hawaii, Alaska & **Canada.)

Lang Manufacturing Equipment ("Lang Equipment") has been skillfully manufactured, carefully inspected and packaged to meet rigid standards of excellence. Lang warrants its Equipment to be free from defects in material and workmanship for (12) twelve consecutive months. Exception: School Food Services for (36) Thirty-six consecutive months effective June 1, 2001, for all full size convection ovens with AP or AT controllers, with the following conditions and subject to the following limitations.

I. This parts and labor warranty is limited to Lang Equipment sold to the original commercial purchaser/users (but not original equipment manufacturers), at its original place of installation, in the continental United States, Hawaii and Canada.

Quartz elements are warranted for ninety (90) days from the date of installation.

II. Damage during shipment is to be reported to the carrier, is not covered under this warranty, and is the sole responsibility of purchaser/user.

III. Lang, or an authorized service representative, will repair or replace, at Lang's sole election, and Lang Equipment, including but not limited to, safety valves, gas and electric components, found to be defective during the warranty period. As to warranty service in the territory described above, Lang will absorb labor and portal to portal transportation costs (time & mileage) for the first (12) twelve months from the date of installation or eighteen (18) months from date of shipment from Lang Manufacturing, whichever ever comes first.

IV. This warranty does not cover routine general maintenance, periodic adjustments, as specified in operating instructions or manuals, and consumable parts such as quartz elements, or labor costs incurred for removal of adjacent equipment or objects to gain access to Lang Equipment. This warranty does not cover defects caused by improper installation, abuse, careless operation, or improper maintenance of equipment.

V. THIS WARRANTY IS EXCLUSIVE AND IS IN LIEU OF ALL OTHER WARRANTIES, EXPRESSED OR IMPLIED, INCLUDING ANY IMPLIED WARRANTY OF MERCHANTABILITY OR FITNESS FOR A PARTICULAR PURPOSE, EACH OF WHICH IS HEREBY EXPRESSLY DISCLAIMED. THE REMEDIES DESCRIBED ABOVE ARE EXCLUSIVE AND IN NO EVENT SHALL LANG BE LIABLE FOR SPECIAL, CONSEQUENTIAL OR INCIDENTAL DAMAGES FOR THE BREACH OR DELAY IN PERFORMANCE OF THIS WARRANTY.

VI. Lang Equipment is for commercial use only. If sold as a component of another (OEM) manufacturer's equipment, or if used as a consumer product, such Equipment is sold AS IS and without any warranty.

***Canada warranty paid in US dollars based on current exchange rates**

STAR MANUFACTURING

10 Sunnen Drive, St. Louis, MO 63143 U.S.A.

(800) 807-9054 (314) 781-2777

Parts & Service (800) 807-9054

www.star-mfg.com