

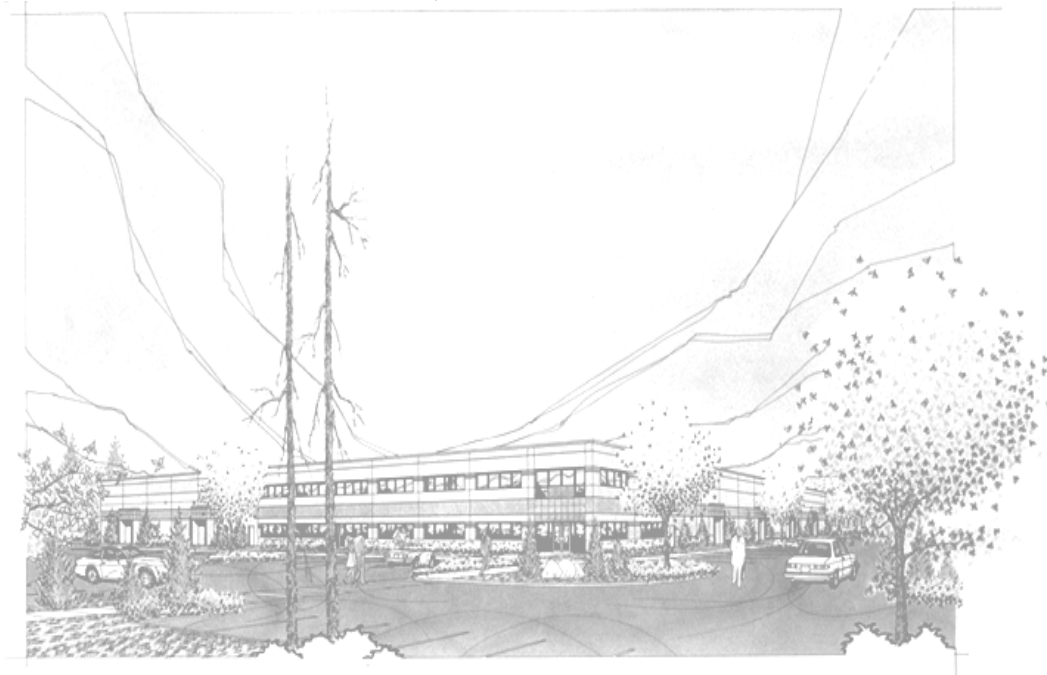





Installation, Operation, & Maintenance
Model: PPP, Electric Air Door Pizza Oven



THE INFORMATION IN THIS MANUAL IS CRUCIAL AND MUST BE RETAINED FOR FUTURE REFERENCE. READ, UNDERSTAND AND FOLLOW THE INSTRUCTIONS AND WARNINGS CONTAINED IN THIS MANUAL.

<u>DANGER</u>	POTENTIALLY HAZARDOUS SITUATION WHICH, IF NOT AVOIDED, COULD RESULT IN DEATH.	
<u>WARNING</u>	POTENTIALLY HAZARDOUS SITUATION WHICH, IF NOT AVOIDED, COULD RESULT IN DEATH OR SERIOUS INJURY.	
<u>CAUTION</u>	POTENTIALLY HAZARDOUS SITUATION WHICH, IF NOT AVOIDED, MAY RESULT IN MINOR OR MODERATE INJURY.	
<u>NOTICE</u>	Helpful operation and installation instructions and tips are present.	

FOR YOUR SAFETY

DO NOT STORE OR USE GASOLINE OR OTHER FLAMMABLE VAPORS AND LIQUIDS IN THE VICINITY OF THIS OR ANY OTHER APPLIANCE.

WARNING: IMPROPER INSTALLATION, ADJUSTMENT, ALTERATION, SERVICE OR MAINTENANCE CAN CAUSE PROPERTY DAMAGE, INJURY OR DEATH. READ THE INSTALLATION, OPERATING AND MAINTENANCE INSTRUCTIONS THOROUGHLY BEFORE INSTALLING OR SERVICING THIS EQUIPMENT.

Model #:	Purchased From:
Serial #:	Location:
Date Purchased:	Date Installed:
Purchase Order #:	For Service, Call:

TABLE OF CONTENTS

CHAPTER	PAGE
TABLE OF CONTENTS	3
READ FIRST	4
SAFETY PROCEDURES	6
EQUIPMENT DESCRIPTION	7
UNPACKING.....	8
INSTALLATION	9
INITIAL START UP.....	11
OPERATION	12
MAINTENANCE & CLEANING	13
TROUBLE SHOOTING	15
ILLUSTRATED PARTS BREAKDOWN.....	17
PARTS LIST	18
WIRING DIAGRAM	19
WARRANTY	21

<u>CAUTION</u>	THE OVEN WEIGHS 850 LBS. FOR SAFE HANDLING, INSTALLER SHOULD OBTAIN HELP AS NEEDED, OR EMPLOY APPROPRIATE MATERIALS HANDLING EQUIPMENT (SUCH AS A FORKLIFT, DOLLY, OR PALLET JACK) TO REMOVE THE UNIT FROM THE SKID AND MOVE IT TO THE PLACE OF INSTALLATION.
<u>CAUTION</u>	ANY STAND, COUNTER OR OTHER DEVICE ON WHICH OVEN WILL BE LOCATED MUST BE DESIGNED TO SUPPORT THE WEIGHT OF THE OVEN (850 LBS.).
<u>CAUTION</u>	SHIPPING STRAPS ARE UNDER TENSION AND CAN SNAP BACK WHEN CUT.
<u>DANGER</u>	THIS APPLIANCE MUST BE GROUNDED AT THE TERMINAL PROVIDED. FAILURE TO GROUND THE APPLIANCE COULD RESULT IN ELECTROCUTION AND DEATH.
<u>WARNING</u>	INSTALLATION OF THE UNIT MUST BE DONE BY PERSONNEL QUALIFIED TO WORK WITH ELECTRICITY AND PLUMBING. IMPROPER INSTALLATION CAN CAUSE INJURY TO PERSONNEL AND/OR DAMAGE TO EQUIPMENT. UNIT MUST BE INSTALLED IN ACCORDANCE WITH ALL APPLICABLE CODES.
<u>NOTICE</u>	The data plate is located behind the screened door under the control panel. The oven voltage, wattage, serial number, wire size, and clearance specifications are on the data plate. This information should be carefully read and understood before proceeding with the installation.
<u>NOTICE</u>	The installation of any components such as a vent hood, grease extractors, fire extinguisher systems, must conform to their applicable National, State and locally recognized installation standards.
<u>NOTICE</u>	During the first few hours of operation you may notice a small amount of smoke coming from the oven, and a faint odor from the smoke. This is normal for a new oven and will disappear after the first few hours of use.
<u>CAUTION</u>	ALWAYS KEEP THE AREA NEAR THE APPLIANCE FREE FROM COMBUSTIBLE MATERIALS.
<u>CAUTION</u>	KEEP FLOOR IN FRONT OF EQUIPMENT CLEAN AND DRY. IF SPILLS OCCUR, CLEAN IMMEDIATELY, TO AVOID THE DANGER OF SLIPS OR FALLS.
<u>WARNING</u>	KEEP WATER AND SOLUTIONS OUT OF CONTROLS. NEVER SPRAY OR HOSE CONTROL CONSOLE, ELECTRICAL CONNECTIONS, ETC.
<u>CAUTION</u>	MOST CLEANERS ARE HARMFUL TO THE SKIN, EYES, MUCOUS MEMBRANES AND CLOTHING. PRECAUTIONS SHOULD BE TAKEN TO WEAR RUBBER GLOVES, GOGGLES OR FACE SHIELD AND PROTECTIVE CLOTHING. CAREFULLY READ THE WARNING AND FOLLOW THE DIRECTIONS ON THE LABEL OF THE CLEANER TO BE USED.



NOTICE

Service on this, or any other, LANG appliance must be performed by qualified personnel only. Consult your authorized service station directory or call the factory at 1-800-224-LANG (5264), or WWW.LANGWORLD.COM For the service station nearest you.



WARNING

BOTH HIGH AND LOW VOLTAGES ARE PRESENT INSIDE THIS APPLIANCE WHEN THE UNIT IS PLUGGED/WIRED INTO A LIVE RECEPTACLE. BEFORE REPLACING ANY PARTS, DISCONNECT THE UNIT FROM THE ELECTRIC POWER SUPPLY.



CAUTION

USE OF ANY REPLACEMENT PARTS OTHER THAN THOSE SUPPLIED BY LANG OR THEIR AUTHORIZED DISTRIBUTORS CAN CAUSE BODILY INJURY TO THE OPERATOR AND DAMAGE TO THE EQUIPMENT AND WILL VOID ALL WARRANTIES.



Lockout Procedure

1. Announce lockout to other personnel.
2. Turn both heat and control power off at main panel.
3. Clear unit of all personnel.
4. Test lockout by turning power switch on and observing if fan(s) come on. Check heater circuit with voltmeter.
5. Perform necessary repairs or tests.
6. Clear unit of personnel before restarting.
7. Turn power on at main panel.
8. Announce unit is “on” to other personnel.

Safety Precautions

The Manufacturer, Lang Manufacturing, hereby disclaims any and all responsibility for injury, damage, loss or other claim that may occur to person or property from improper alteration, modification, addition, operation, maintenance or service, whether it be mechanical, electrical, fuel, operator motor or otherwise, which may occur from such improper alteration, modification, addition, operation, maintenance or service to this piece of equipment.

Safety Considerations

Your Lang Pizza Oven is manufactured to rigid standards. This equipment is N.S.F and U.L. listed and meets safety and sanitation standards.

The presence of safety equipment control and interlocks on an appliance and attendant components of installation cannot in and of themselves, assure absolute safety of operation. Diligent, capable, well trained operators and maintenance personnel, as well as proper programs of operation and maintenance, are essential to the safe and reliable operation of this appliance.

- A. The **responsibility of the manufacturer** is to supply suitable, comprehensive instructions and recommendations for the operation and maintenance of the appliance.
- B. Trained qualified and factory-authorized personnel must perform all operation, maintenance and repair of these appliances. It is the **responsibility of the owner / operator** to ensure that this happens.
- C. A regular periodic program of cleaning, inspection and maintenance must be established and comprehensive maintenance records maintained. It is the **sole responsibility of the user** to establish, schedule and enforce the frequency and scope of these programs in keeping with recommended practice and with due consideration given to actual operating conditions.
- D. The appliance must be operated within the limits, which will not exceed the working limits of any component within the appliance as a whole.

EQUIPMENT DESCRIPTION

Lang Model: PPP **Air Door Pizza Oven**

Exterior

The oven dimensions are 21" (53.34cm) High, 46" (116.84cm) Deep, and 75" (190.5cm) Wide.

The Sides, Bottom, and Rear wall are constructed stainless steel.

The Pizza oven has a 46.5" (118.11cm) Wide X 8.5" (21.59cm) High opening.

Interior

The interior dimensions are 55.25" (140.35cm) Wide, 36" (91.44cm) Deep, and 8.5" (21.59cm) High.

The interior is designed for baking directly on the cordierite deck surface of the oven.

Oven Capacity

8" Pizza	28 each
10" Pizza	15 each
12" Pizza	12 each
14" Pizza	8 each
16" Pizza	6 each
18" Pizza	6 each

Controls

The oven power switch turns on the Air Door, which is a gentle curtain of hot air that flows up across the oven opening preventing any heat from escaping the oven.

The oven is provided with both an upper and a bottom-heating element. The upper element is visible in the top of the oven the lower oven element is under the cordierite deck of the oven.

Both of these oven elements can be regulated with independently controlled three heat switches. These switches provide the proper ratio of top and bottom heat.

The oven is also provided with an adjustable thermostat that controls the overall average temperature of the oven from 300°F-650°F.

Receiving the Oven

Upon receipt, check for freight damage, both visible and concealed. Visible damage should be noted on the freight bill at the time of delivery and signed by the carrier's agent. Concealed loss or damage means loss or damage, which does not become apparent until the merchandise has been unpacked. If concealed loss or damage is discovered upon unpacking, make a written request for inspection by the carrier's agent within 15 days of delivery. All packing material should be kept for inspection. Do not return damaged merchandise to Lang Manufacturing Company. File your claim with the carrier.

Location

Prior to un-crating, move the oven as near its intended location as practical. The crating will help protect the unit from the physical damage normally associated with moving it through hallways and doorways.

Un-crating

The oven will arrive completely assembled inside a wood frame covered by cardboard box and strapped to a skid. **Remove the cardboard cover, cut the straps and remove the wood frame.**

CAUTION THE OVEN WEIGHS 850 LBS. FOR SAFE HANDLING, INSTALLER SHOULD OBTAIN HELP AS NEEDED, OR EMPLOY APPROPRIATE MATERIALS HANDLING EQUIPMENT (SUCH AS A FORKLIFT, DOLLY, OR PALLET JACK) TO REMOVE THE UNIT FROM THE SKID AND MOVE IT TO THE PLACE OF INSTALLATION.



CAUTION ANY STAND, COUNTER OR OTHER DEVICE ON WHICH OVEN WILL BE LOCATED MUST BE DESIGNED TO SUPPORT THE WEIGHT OF THE OVEN (850 LBS.).



CAUTION SHIPPING STRAPS ARE UNDER TENSION AND CAN SNAP BACK WHEN CUT.



The oven may now be removed from the skid.

INSTALLING THE LEGS

Legs are available for the single, double, and triple deck installations. Single deck installations require a 34-inch leg. Double deck installations require a 25-inch and triple deck installations require a 6-inch leg.

To install the 34-inch legs, place some cardboard on the floor and gently tip the oven onto its back. Fasten two legs to the oven front corners using the four 5/16 inch bolts provided in the leg kit. Lift the oven onto its front legs and block the back up using one of the 34-inch legs set upside down in the center rear of the oven body. Install the last 34-inch leg onto the oven body on the control side rear. Gently lift the oven rear, remove the leg set to support the oven center and install it on the last rear corner.

To install the 25-inch legs follow the same directions for the 34-inch legs before stacking the second deck onto the bottom deck.

To install the 6-inch legs follow the same directions for the 34-inch legs before stacking the second deck onto the bottom deck.

INSTALLATION

DANGER

THIS APPLIANCE MUST BE GROUNDED AT THE TERMINAL PROVIDED. FAILURE TO GROUND THE APPLIANCE COULD RESULT IN ELECTROCUTION AND DEATH.



WARNING

INSTALLATION OF THE UNIT MUST BE DONE BY PERSONNEL QUALIFIED TO WORK WITH ELECTRICITY AND PLUMBING. IMPROPER INSTALLATION CAN CAUSE INJURY TO PERSONNEL AND/OR DAMAGE TO EQUIPMENT. UNIT MUST BE INSTALLED IN ACCORDANCE WITH ALL APPLICABLE CODES.



NOTICE

The data plate is located behind the screened door under the control panel. The oven voltage, wattage, serial number, wire size, and clearance specifications are on the data plate. This information should be carefully read and understood before proceeding with the installation.



NOTICE

The installation of any components such as a vent hood, grease extractors, fire extinguisher systems, must conform to their applicable National, State and locally recognized installation standards.



ELECTRICAL CONNECTION

Install the legs to the oven.

Electrical service connections can be made through an 1 1/4 knockout in the bottom of the oven below the electrical controls.

Remove the cover attached to the oven circuit breakers for access.

Power connections can be made to the wires extending from the bottom of the circuit breakers. Each wire has three numbers approximately two feet apart.

For Service connection and Phasing refer to the wiring diagram located at the back of this manual.

Pull the wires out the front. Observe the three sets of numbers. Cut the wires as indicated:

1. For bottom deck or single deck installations cut each wire 3-inches below numbers 1; 2; 3; 4.
2. For middle deck or double deck installations cut each wire 3-inches below numbers 5; 6; 7; 8.
3. For top deck or triple deck installations cut each wire 3-inches below numbers 9; 10; 11; 12.

Place second oven on top of bottom oven and route the four wires through the bushing of the lower oven. They should now be in proximity of the wires from the bottom deck.

A single power connection can now be made at the bottom deck. Through the hinged door of the bottom oven, group and tape together the wires as indicated in the service connection chart located in the wiring diagram at the end of this manual.

VENTILATION AND CLEARANCES

Standard minimum clearance from combustible construction is as follows:

4" from side

4" from back

6" from floor

These ovens may be set directly, without legs, on a curbed base or **non-combustible** floor.

If the oven is set without legs on a **non-combustible** floor or a curbed base, maintain a 4-inch back clearance.

If the oven is set directly against a **non-combustible** back wall, maintain a 6-inch clearance to the floor.

Do not install the oven closer than 4 inches from another oven on the right hand side (control panel side).

Do not install the oven closer than 12 inches from an uncontrolled heat source (char broiler etc.) on the right side.

Keep the appliance area free and clear of combustible material and do not obstruct the flow of combustion or ventilation air.

The installation of any components such as a vent hood, grease extractors, and/or fire extinguisher systems, must conform to their applicable nationally recognized installation standards.

INITIAL START UP

NOTICE

During the first few hours of operation you may notice a small amount of smoke coming from the oven, and a faint odor from the smoke. This is normal for a new oven and will disappear after the first few hours of use.



Each oven is preheated, tested and calibrated at the factory before shipment. However, due to temperature and climate changes during shipment the oven can absorb moisture and should be dried out before attempting to bake.

Prior to putting any oven into full time operation at normal cooking temperatures, it must be thoroughly "seasoned" or dried out. Moisture absorption in the closed spaces, in the insulation and even inside the heating elements can cause future trouble if not properly treated.

Before the initial use of the oven, the element must be thoroughly allowed to dry out. This is done by setting the top and bottom oven switches to the "low" position, and setting the thermostat to 350°F. Allow the oven/ ovens to saturate until all vapor and condensation has been eliminated. For best operating results allow the ovens to thoroughly dry out. Allow 8 to 12 hours for this process.

If the unit is out of use for three or more days, a one-hour preheat schedule should be used, especially when exposed to high humidity and/or cool temperatures.

OPERATION

CAUTION

ALWAYS KEEP THE AREA NEAR THE APPLIANCE FREE FROM COMBUSTIBLE MATERIALS.

CAUTION

KEEP FLOOR IN FRONT OF EQUIPMENT CLEAN AND DRY. IF SPILLS OCCUR, CLEAN IMMEDIATELY, TO AVOID THE DANGER OF SLIPS OR FALLS.



GENERAL

This oven is designed to give well regulated, even heat. It should be thoroughly preheated before being used. It is advantageous from the operating cost standpoint, to operate with the thermostat set at the lowest possible position that will satisfactory perform the baking and with the door shut during preheat and slack business periods.

The ovens may, of course, be preheated with the 4 heat switches set at a lower position than "High", but the time required will be proportionally longer. After preheating, set the two 4 heat switches for proper ratio of "top" and "bottom" heat to suit the product to be baked or roasted.

COOKING

Even heat in the oven is important for proper baking results. It is best to allow the oven to preheat about fifty minutes to 500°F before baking. Set the top and bottom heat control switches to obtain the proper ratio of top and bottom heat to suit your product. (See suggested temperature and control settings).

Equal baking results will be obtained with the door open or closed. The door is provided to conserve energy during preheat or slow periods.

To select the balance of top and bottom heat follow these directions:

1. If product is overdone on the bottom turn the bottom switch down or the top switch up.
2. If product is over done on the top, turn top switch down or bottom switch up.

To select the correct temperature, follow these procedures.

1. If a product is taking too long to bake, turn the thermostat up.
2. If a product is not done inside, turn thermostat down and increases baking time.

Normally, Pizzas will not have to be moved or rotated during baking; however, various dough mixes, excessive draft conditions, the quantity and type of toppings, and other variables may require the pizzas to be shifted or rotated for a more even bake. Also during very busy periods, repeatedly placing a pizza in the same spot would cause the deck temperature to drop somewhat while the heat remains constant. This results in an under done crust or a burnt top. To remedy this condition try not to load pizza after pizza in exactly the same location. Allow a two minute rest for each section of the oven at least once every half hour

SUGGESTED TEMPERATURE AND CONTROL SETTING'S

Pizza Type	Pie On Pan Or Deck	Business Is Busy Or Slow	Thermostat Setting	Top Switch Setting	Bottom Switch Setting	Time In Minutes
Thick / Thin crust, Light topping	Deck	Slow	500°-550°	Med Low	Med Low	3-7
Thick / Thin crust, Light topping	Deck	Busy	500°-550°	Med Hi	Med Hi	3-7
Thick / Thin crust, Heavy topping	Deck	Slow or Busy	475°-550°	Med Low	Med Hi	6-10
Thick / Thin crust, Light topping	Pan	Slow or Busy	475°-550°	Med Low	Med Hi	5-8
Thick / Thin crust, Heavy topping (Deep Dish)	Pan	Slow or Busy	475°-550°	Med Low	Med Hi	6-11

MAINTENANCE & CLEANING

WARNING

KEEP WATER AND SOLUTIONS OUT OF CONTROLS. NEVER SPRAY OR HOSE CONTROL CONSOLE, ELECTRICAL CONNECTIONS, ETC.



CAUTION

MOST CLEANERS ARE HARMFUL TO THE SKIN, EYES, MUCOUS MEMBRANES AND CLOTHING. PRECAUTIONS SHOULD BE TAKEN TO WEAR RUBBER GLOVES, GOGGLES OR FACE SHIELD AND PROTECTIVE CLOTHING. CAREFULLY READ THE WARNING AND FOLLOW THE DIRECTIONS ON THE LABEL OF THE CLEANER TO BE USED.



DAILY CLEANING

Remove, empty and clean the two section crumb tray located near the front bottom of the oven. Clean the area under the crumb tray with a vacuum cleaner. The 3/16-inch wide slots located along the front edge of the crumb tray are the orifices for the Air-Curtain; therefore the orifices must be free of obstructions. The crumb trays must be installed in the oven when in use.

The oven should be thoroughly cleaned once a day to insure against accumulation of foreign material.

- Always start with a cold oven.
- The stainless exterior can easily be cleaned using Lang Mfg. Prime Shine (72804-41) oven cleaner.
- Always follow the cleaner manufacturer's instructions when using any cleaner.
- Care should be taken to prevent caustic cleaning compounds from coming in contact with the aluminized blower wheel and aluminized inside of the oven.
- Discoloration or heat tint may be removed using Lang Mfg. Carbon Release (72804-32) oven cleaner.
- Always apply these cleaners when the oven is cold and rub in the direction of the metal's grain.

WEEKLY CLEANING

Any foreign material such as corn meal, flour, crust, and topping should be vacuumed from beneath the crumb catchers weekly.

CLEANING THE DECK

The deck may be cleaned during usage with a brush and scraper. Periodically, the decks should be turned over. This produces a pyrolytic or self-cleaning action to the underside of the deck. Thusly, any spillage will be burnt off and upon returning, your deck will be clean.

Remove the deck by using two flat bladed screwdrivers to “walk up” the front edge of the right deck. When deck is high enough, grasp it firmly and pull over the top of other deck. Remove from the front of the oven.

CHANGING LIGHTS

Turn circuit breakers off. Two screws hold the light guards in place. Remove these screws and pull lamp guard out of the oven. The oven lamp (31603-07) may now be unscrewed for replacement.

CALIBRATION

Calibration Check

- Place thermometer or thermocouple in the center of oven cavity.
- Set thermostat to 350°F and place both 3-heat switches in the “HIGH” position.
- Allow the oven to Preheat for at least half an hour.
- Note cycle on temperatures and cycle off temperatures for 3 cycles. (Red indicator light indicates when oven is calling for heat)
- After 3 cycles average the temperature (+/- 5°F). (Add all six temperatures and divide by 6)

Calibration Adjustment

- A 5/64” allen-wrench will be required to remove the knob from the thermostat shaft.
- A 1/16” flat blade screwdriver with a 2” shaft is required to make adjustments on the thermostat.
- Maintain the oven temperature at 350°F.
- Without turning the thermostat, remove the knob.
- Locate the adjustment screw at the base of the shaft and insert the screwdriver.
- Grasp the shaft and turn the screwdriver. Counterclockwise to increase and clockwise to decrease (1/8 of a turn will move the temperature 5-7 ° in either direction).
- Reinstall the oven knob and recheck the oven temperature.

Symptoms

What follows is a chart of Symptoms, Possible Causes, and Remedy's to aid in diagnosing faults with the oven.

Refer to the Symptoms column to locate the type of failure then to the Possible Cause for the items to be checked. On the following pages is a chart with the possible causes and the test to properly identify the problem.

SYMPTOM	POSSIBLE CAUSE
Oven will not heat	<ul style="list-style-type: none"> • No power to Oven • Internal breaker tripped • Blown fuses • Defective power switch • Defective thermostat • Defective contactor • Defective 4-heat switch • Defective oven element
Fan will not operate	<ul style="list-style-type: none"> • No power to oven • Internal breaker tripped • Blown fuses • Defective power switch • Defective terminal block • Defective motor
Product is burning	<ul style="list-style-type: none"> • Product is cooked too long • Thermostat out of calibration • Failed Thermostat • Failed 4-heat switch
Product under done	<ul style="list-style-type: none"> • Product is not cooking long enough • Thermostat out of calibration • Failed thermostat • Failed 4-heat switch

TROUBLESHOOTING CONT'D

NOTICE

Service on this, or any other, LANG appliance must be performed by qualified personnel only. Consult your authorized service station directory or call the factory at 1-800-224-LANG (5264), or WWW.LANGWORLD.COM For the service station nearest you.



WARNING

BOTH HIGH AND LOW VOLTAGES ARE PRESENT INSIDE THIS APPLIANCE WHEN THE UNIT IS PLUGGED/WIRED INTO A LIVE RECEPTACLE. BEFORE REPLACING ANY PARTS, DISCONNECT THE UNIT FROM THE ELECTRIC POWER SUPPLY.



CAUTION

USE OF ANY REPLACEMENT PARTS OTHER THAN THOSE SUPPLIED BY LANG OR THEIR AUTHORIZED DISTRIBUTORS CAN CAUSE BODILY INJURY TO THE OPERATOR AND DAMAGE TO THE EQUIPMENT AND WILL VOID ALL WARRANTIES.



TESTS

Possible Cause	TEST
Blown fuses	<ul style="list-style-type: none"> • No test available, replace fuses
Failed or tripped internal breaker	<ul style="list-style-type: none"> • Reset breaker
Failed thermostat	<ul style="list-style-type: none"> • Verify calibration • Replace if necessary*
Failed Contactor	<ul style="list-style-type: none"> • Verify that coil has correct voltage* • Verify that coil has continuity* • Verify that contactor points move
Failed 3-heat switch	<ul style="list-style-type: none"> • Call factory or consult Service manual for correct checks on each switch*
Failed element	<ul style="list-style-type: none"> • Remove the wires and check for continuity across the element*
Defective motor	<ul style="list-style-type: none"> • Verify that motor wheel spins freely • Verify that motor has correct voltage*
Product is not baking properly	<ul style="list-style-type: none"> • Verify thermostat calibration.

* A factory authorized service representative should perform this work.

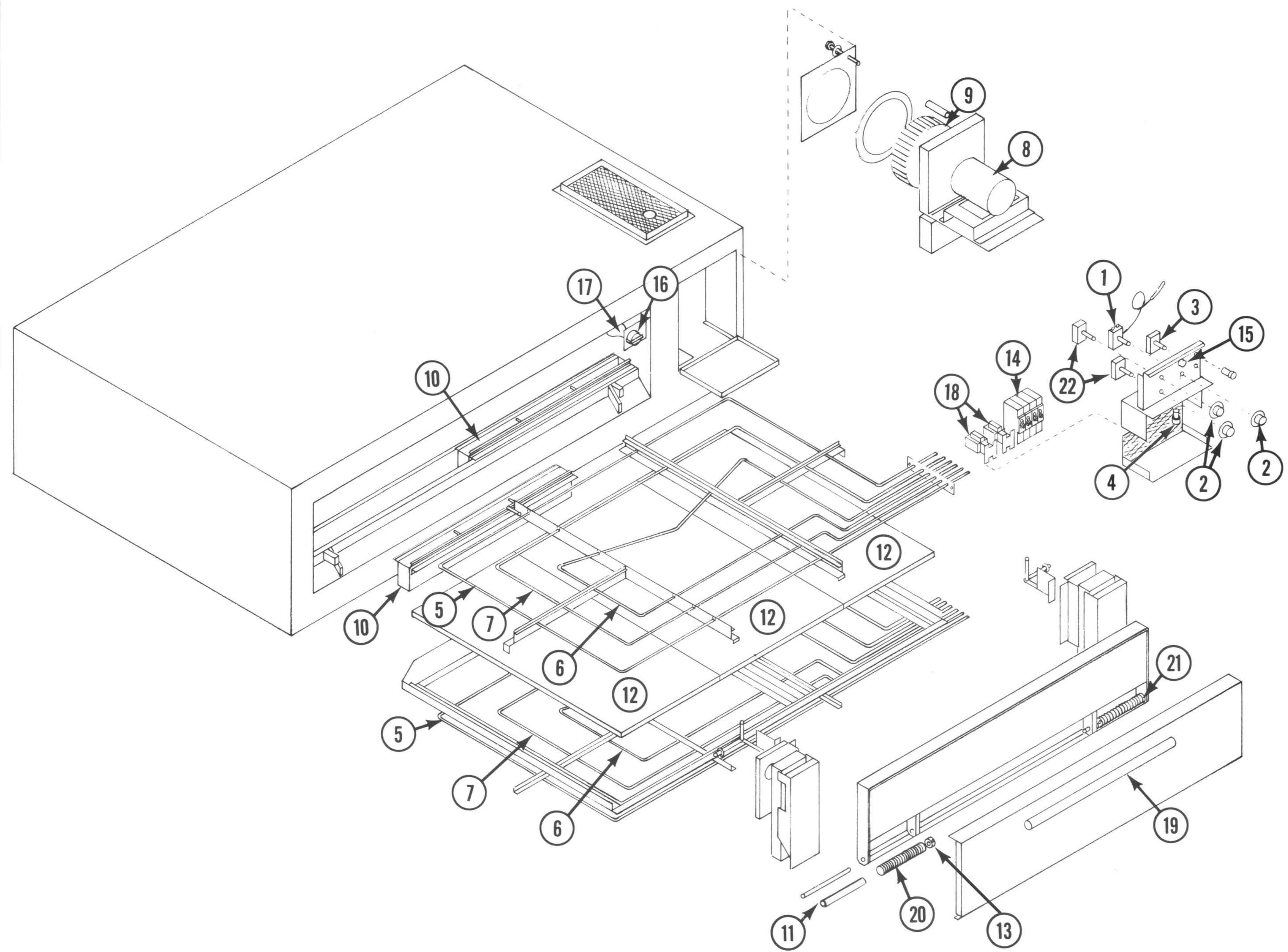

PARTS LIST**PPP****ELECTRIC AIR DOOR PIZZA OVEN**

ITEM	DESCRIPTION	PART NO.
1	Thermostat 300-650°F Oven	30402-24
2	Knob, Thermostat / Four Heat Switch	70701-28
3	Toggle Switch, On / Off	30303-06
4	Fuse 15 Amp 300 Volt	30900-10
4A	Fuse Holder 15 Amp	30901-08
5	Element PPP 208 Volt O/S 2400 Watts	11151-33
5A	Element PPP 240 Volt O/S 2400 Watts	11151-36
5B	Element PPP 480 Volt O/S 2400 Watts	11151-39
6	Element PPP 208 Volt I/S 2000 Watts	11151-35
6A	Element PPP 240 Volt I/S 2000 Watts	11151-38
6B	Element PPP 480 Volt I/S 2000 Watts	11151-41
7	Element PPP 208 Volt Middle 1500 Watts	11151-34
7A	Element PPP 240 Volt Middle 1500 Watts	11151-37
7B	Element PPP 480 Volt Middle 1500 Watts	11151-40
8	Motor 1/3 HP 480 Volt	30200-03
8A	Motor 1/3 HP 208/240 Volt	30200-12
9	Blower Wheel	71500-01
10	Crumb Tray Nozzle Left Hand & Right Hand	50301-65
11	Door Rod 14 3/4" Long	50800-43
12	Cordierite Deck Material 1" x 17 7/8" x 35 5/16"	50500-07-1
13	Tension Disc 1 1/4" Diameter – Door Spring	50800-42
14	Circuit Breaker 208/240 Volt 1-Pole	31800-01
14A	Circuit Breaker 480 Volt 3-Pole	31800-04
15	Pilot Light 208/240 Volt 6" Lead Black Body	31601-01
16	Lamp Socket	31602-04
17	Lamp 250 Volt	31603-07
18	Contactors 2 Pole 208/240 VAC	30701-03
19	Handle Assembly Oven Door	70603-15
20	Spring Left Side 9 1/2" Long – Oven Door	51001-17
21	Spring Right Side 9 1/2" Long – Oven Door	51001-18
22	Switch Rotating 3 Heat	30304-06
N/S	Terminal Strip, 4-Pole, Push On	30501-03
N/S	Transformer 480/240 VAC	31400-04
N/S	Panel Label, Pizza Oven, Air Door	60301-22

WIRING DIAGRAM

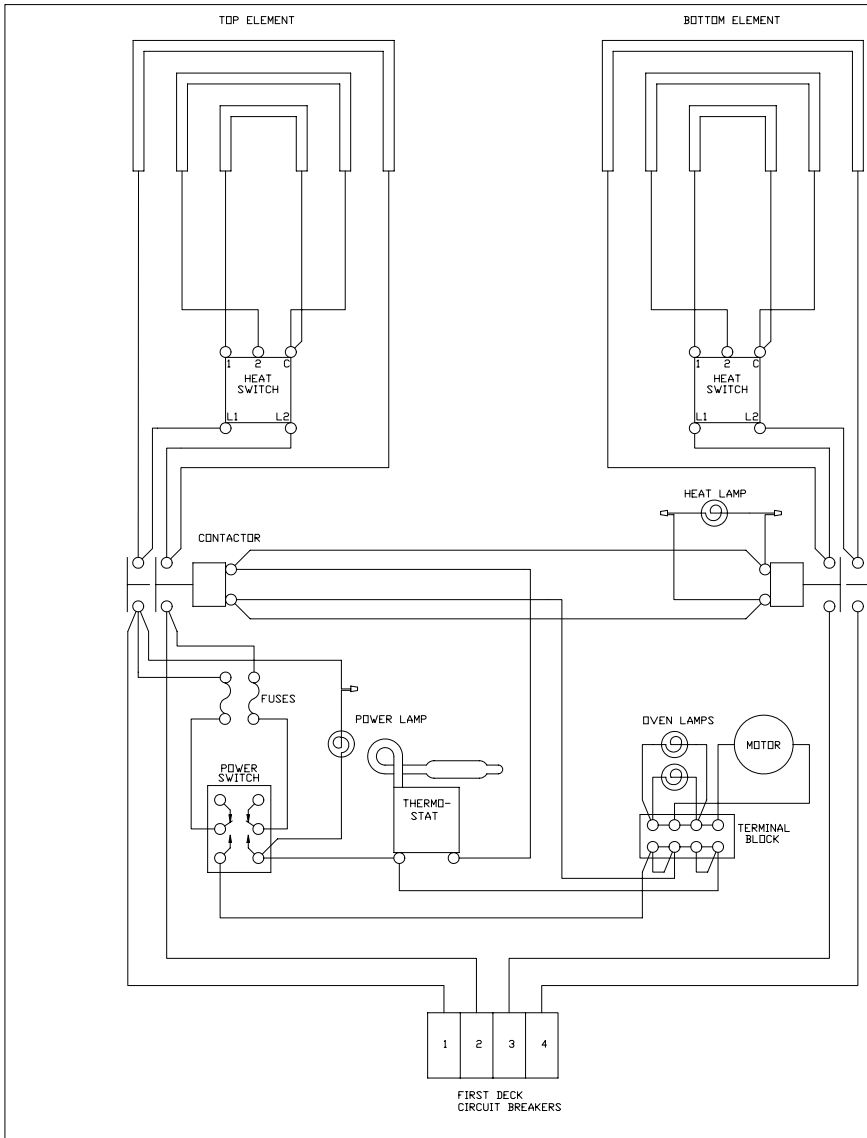

REVISION BLOCK						
REV	ECN NO.	DESCRIPTION	DR:	MFG	ENG	DATE
		REVISED & REDRAWN	MLS			5-1-02

MODEL NUMBER	AMPS PER LINE					
	THREE PHASE			SINGLE PHASE		
	L1	L2	L3	L1	L2	
PPP-1	1,4	2	3	1,3	2,4	
PPP-2	1,4,7	2,5,8	3,6	1,3,5,7	2,4,6,8	
PPP-3	1,4,7,10	2,5,8,11	3,6,9,12	1,3,5,7,9,11	2,4,6,8,10,12	

MODEL NUMBER	AMPS PER LINE							
	THREE PHASE						SINGLE PHASE	
	208 VOLTS			240 VOLTS			208V	240V
	L1	L2	L3	L1	L2	L3		
PPP-1	50.4	29.8	28.4	43.7	25.8	24.6	58.2	50.4
PPP-2	74.9	51.6	50.4	65.0	44.7	43.7	116.3	100.8
PPP-3	100.6	100.6	100.6	86.6	86.8	86.6	174.5	151.3

MODEL NUMBER	LOADING			
	K.W. PER PHASE			TOTAL K.W.
	L1 - L2	L2 - L3	L3 - L1	
PPP-1	6.2	0.0	5.9	12.1
PPP-2	12.1	6.2	5.9	24.2
PPP-3	12.2	12.1	12.1	36.3

1			
QTY	ITEM	PART NUMBER	DESCRIPTION / MATERIAL
LANG MANUFACTURING			
DR:	MLS	DATE: 5-1-02	TITLE: ELECTRIC PIZZA OVEN
CK:		DATE: 5-1-02	
TOLERANCES		DECIMALS	
FRACTIONS		± 1/64	
ANGLES		± .01	
UNLESS OTHERWISE SPECIFIED		DIMENSIONS ARE IN INCHES	
SCALE:	1	NEXT HIGHER ASSY.	SHEET
		DRAWING NUMBER	REV
		61112-04	B
		1 OF 1	

**THIS PAGE IS
INTENTIONALLY
LEFT BLANK**

Lang Manufacturing Limited Warranty to Commercial Purchasers* (Contiguous U.S. Including Hawaii, Alaska & **Canada.)

Lang Manufacturing Equipment (“Lang Equipment”) has been skillfully manufactured, carefully inspected and packaged to meet rigid standards of excellence. Lang warrants its Equipment to be free from defects in material and workmanship for (12) twelve consecutive months, with the following conditions and subject to the following limitations.

I. This parts and labor warranty is limited to Lang Equipment sold to the original commercial purchaser/users (but not original equipment manufacturers), at its original place of installation, in the continental United States, Hawaii and Canada.

Quartz elements are warranted for ninety (90) days from the date of installation.

II. Damage during shipment is to be reported to the carrier, is not covered under this warranty, and is the sole responsibility of purchaser/user.

III. Lang, or an authorized service representative, will repair or replace, at Lang’s sole election, and Lang Equipment, including but not limited to, safety valves, gas and electric components, found to be defective during the warranty period. As to warranty service in the territory described above, Lang will absorb labor and portal to portal transportation costs (time & mileage) for the first (12) twelve months from the date of installation or eighteen (18) months from date of shipment from Lang Manufacturing, which ever comes first.

IV. This warranty does not cover routine general maintenance, periodic adjustments, as specified in operating instructions or manuals, and consumable parts such as quartz elements, or labor costs incurred for removal of adjacent equipment or objects to gain access to Lang Equipment. This warranty does not cover defects caused by improper installation, abuse, careless operation, or improper maintenance of equipment.

V. THIS WARRANTY IS EXCLUSIVE AND IS IN LIEU OF ALL OTHER WARRANTIES, EXPRESSED OR IMPLIED, INCLUDING ANY IMPLIED WARRANTY OF MERCHANTABILITY OR FITNESS FOR A PARTICULAR PURPOSE, EACH OF WHICH IS HEREBY EXPRESSLY DISCLAIMED. THE REMEDIES DESCRIBED ABOVE ARE EXCLUSIVE AND IN NO EVENT SHALL LANG BE LIABLE FOR SPECIAL, CONSEQUENTIAL OR INCIDENTAL DAMAGES FOR THE BREACH OR DELAY IN PERFORMANCE OF THIS WARRANTY.

VI. Lang Equipment is for commercial use only. If sold as a component of another (OEM) manufacturer’s equipment, or if used as a consumer product, such Equipment is sold AS IS and without any warranty.

***Canada warranty paid in US dollars based on current exchange rates.**