



Holman[®]

PROVEYOR MULTI-PURPOSE OVEN

MODEL
314HX, 318HX Series

Installation and
Operation
Instructions

2M-HG0105 Rev. D 09/2019

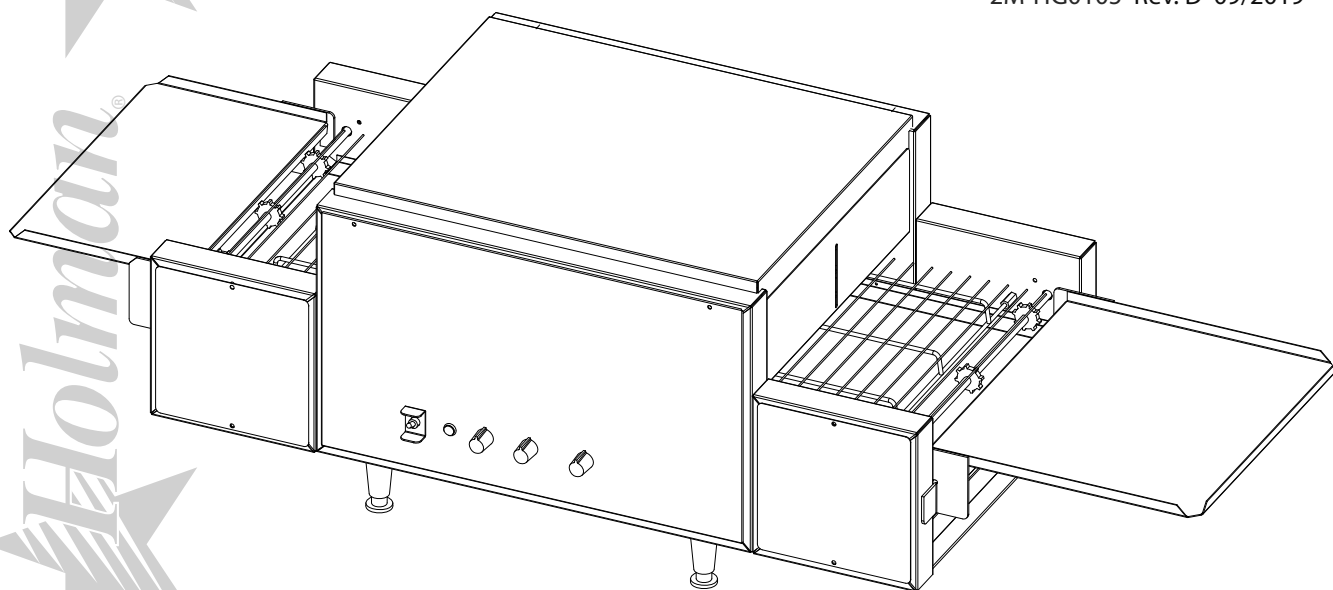

314HX



SAFETY SYMBOL



These symbols are intended to alert the user to the presence of important operating and maintenance instructions in the manual accompanying the appliance.

RETAIN THIS MANUAL FOR FUTURE REFERENCE NOTICE

Using any part other than genuine Star factory supplied parts relieves the manufacturer of all liability.

Star reserves the right to change specifications and product design without notice. Such revisions do not entitle the buyer to corresponding changes, improvements, additions or replacements for previously purchased equipment.

Due to periodic changes in designs, methods, procedures, policies and regulations, the specifications contained in this sheet are subject to change without notice. While Star International Holdings Inc., Company exercises good faith efforts to provide information that is accurate, we are not responsible for errors or omissions in information provided or conclusions reached as a result of using the specifications. By using the information provided, the user assumes all risks in connection with such use.

MAINTENANCE AND REPAIRS

Contact your local authorized service agent for service or required maintenance.

Please record the model number, serial number, voltage and purchase date in the area below and have it ready when you call to ensure a faster service.

Model No. _____
Serial No. _____
Voltage _____
Purchase Date _____

Authorized Service Agent Listing

Reference the listing provided with the unit

or

for an updated listing go to:

Website: www.star-mfg.com
E-mail customerservice@star-mfg.com

Service Help Desk

Business Hours: 8:00 am to 4:30 p.m. Central Standard Time

Telephone: (800) 264-7827

Fax: (314) 781-2714

E-mail customerservice@star-mfg.com

Website: www.star-mfg.com

Mailing Address: Star Manufacturing International Inc.
265 Hobson Street
Smithville, TN 37166
U.S.A

TABLE OF CONTENTS

	PAGE
Maintenance and Repairs	2
Star Contact information	2
Specifications	3
General Information Data	4
Inspection & Assembly	4
Assembly and Installation	4
Heating Elements	5
Cooling System	5
Final Check	5
Electrical Connection	5
Stacking Ovens	6
Daily Operation	7
Oven Components	7
Operating Hints & Safety	7
Cleaning	8
Maintenance Procedures	11
Troubleshooting Guide	12
Limited Equipment Warranty	13
Wiring Diagram	14-17
Exploded View Illustration	18-25
Parts List 314HX	19
Parts List 318HX	25
Control Box Configuration	26

Specifications						
Model	Voltage	Hz	Watts	Amps	Phase	Cord
314HX	208V	50	5,400	8.7	3Ph	6-50P
	240V					6-30P
318HX	208V		6,200	9.9	3Ph	6-50P
	240V					6-30P
Dimensions			Weight			
	Width	Depth	Height	Installed	Shipping	
314HX	60" (152.4 cm)	21 1/4" (54cm)	16 1/8" (40cm)	86lbs (40kg)	115lbs (52kg)	
318HX		24 7/8" (63.2cm)		96lbs (44kg)	130lbs (59kg)	



GENERAL INSTALLATION DATA

This equipment is designed and sold for commercial use only by personnel trained and experienced in its operation and is not sold for consumer use in and around the home nor for use directly by the general public in food service locations.

Before using your new equipment, read and understand all the instructions & labels associated with the unit prior to putting it into operation. Make sure all people associated with its use understand the units operation & safety before they use the unit.

All shipping containers should be checked for freight damage both visible and concealed. This unit has been tested and carefully packaged to insure delivery of your unit in perfect condition. If equipment is received in damaged condition, either apparent or concealed, a claim must be made with the delivering carrier.

Concealed damage or loss - if damage or loss is not apparent until after equipment is unpacked, a request for inspection of concealed damage must be made with carrier within 15 days. Be certain to retain all contents plus external and internal packaging materials for inspection. The carrier will make an inspection and will supply necessary claim forms.

INSPECTION & ASSEMBLY

UNCRATING AND INSPECTING

Unpack the unit and components from the shipping container. Remove all visible packing material and those from inside the cooking chamber. If damage is discovered, file a claim immediately with the carrier that handled the shipment. Do not operate the unit if it was damaged during shipping.

The following should be included: Proveyor Multi-Purpose Oven, Stainless Steel Load Up & Unload Trays, 4 Stainless Steel Legs.



REMOVE ALL HEATING ELEMENT SHIPPING SUPPORTS PRIOR TO PLACING YOUR UNIT INTO OPERATION.

ASSEMBLY AND INSTALLATION

The unit was shipped with certain assembly required, plug into a standard outlet specified for its voltage and amp draw. If improper electrical supply is determined, contact a qualified electrician prior to using the unit. Removal and replacement of the power cord and plug will void the warranty. For assistance, contact your local authorized service agent for service or required maintenance.

Attach the 4 legs by screwing them into the weld nuts located on the bottom of the unit. When complete, use two people to carefully turn the unit upright. Level unit by adjusting the feet (approximately 1/2" adjustment). Never operate unit without proper legs in place.

Before using the unit for the first time, wipe down the exterior with a damp cloth.



CAUTION

Allow enough space around the oven for adequate ventilation. Do not operate the unit without the crumb tray properly positioned. Overheating and poor baking may occur. Read all labels on the unit and follow their instructions.

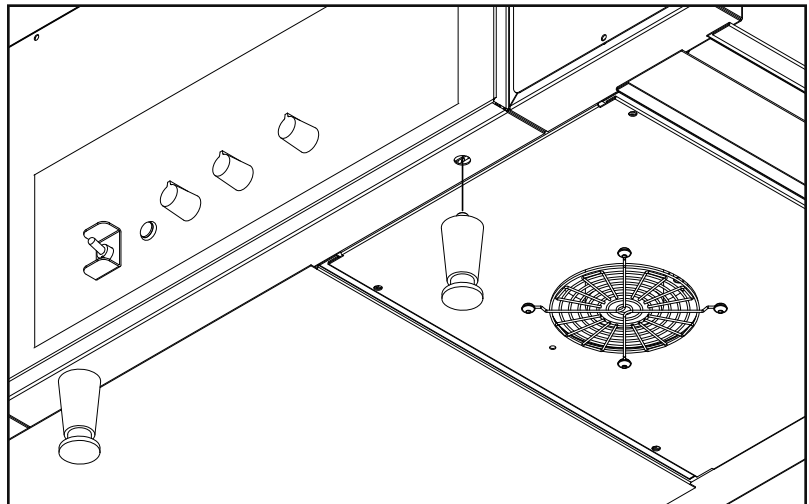

LEG INSTALLATION

ASSEMBLY AND INSTALLATION continued

Install unit in its operating position allow sufficient space for operating personnel. Install the Load, Unload and Crumb Trays as shown, making sure the ends are at least 6" from any vertical combustible surfaces.

Have an electrician connect input power to the unit(s) in accordance with local electrical codes. A connection terminal block is inside the left side cavity for models not provided with a cord and plug set.

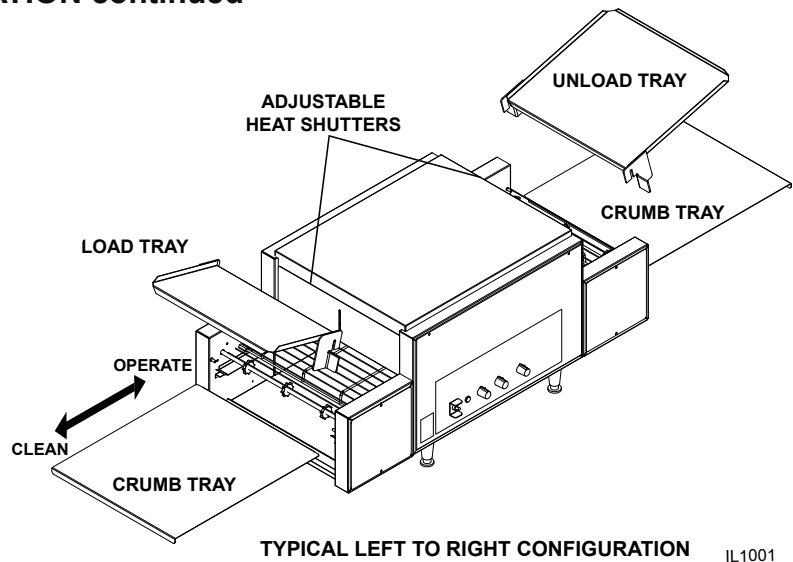

HEATING ELEMENTS

Inspect all heating elements in the unit for breakage. Every unit is properly tested prior to leaving the factory, but damage may of occurred during shipping. If a broken tube is found, do not apply power to the unit. If everything checks out, Turn on Main Power Switch, Turn both heat controls and conveyor belt speed control to the maximum setting and check all heater tubes and conveyor for proper operation.

COOLING SYSTEM

After the unit is initially turned on, allow 5 to 8 minutes for the fan cooling system to come on. Once on, check the air intake area located under the unit and be sure that there is a sufficient flow of air into the control box. Keep area under the unit clean from obstructions that may result in restricted air flow to the control box. Restricting the air flow will cause the unit to run hotter then designed, causing the Hi-Limit to turn unit off. See the Oven Components section on page 7 for control box & Hi-Limit Reset locations.

FINAL CHECK

If all heaters and conveyor systems are operating properly, switch the master on/off switch to the OFF position and allow unit to cool, the fan will continue to circulate air, cooling the unit until the internal temperatures have been decreased.

If a problem is discovered during any of these start-up procedures, immediately switch the master on/off switch to the **OFF** position and notify the Star Service Department at (314) 634-6303.

ELECTRICAL CONNECTION

Before making any electrical connection to this unit, check that the power supply is adequate for the voltage, amperage and requirements stated on the rating plate.

A wiring diagram is included herewith.

Disconnect the unit from the power source before installing or removing any parts.

Be absolutely sure that the ground connection for the receptacle is properly wired. Do not connect equipment to power without proper ground connections. Improper grounding may result in personal injury or fatality.

DO NOT CUT OR REMOVE THIS PLUG OR GROUNDING PRONG FROM THE PLUG.

CONNECT/PLUG UNIT INTO DEDICATED A.C. LINE ONLY SPECIFIED ON THE DATA PLATE OF THE UNIT.



STACKING OVENS

When stacking two Holman Proveyor Ovens a stacking spacer with an external air duct **MUST** be used to prevent overheating of the control box of the top oven.

1. If a cart is to be used with units, place bottom unit on cart and align leg holes of unit with the holes on the cart. Insert 3/8" bolts through cart and into leg holes to secure bottom unit to cart as shown below.
2. Place stacking spacer on top of bottom oven with internal air duct facing up and towards the rear of the oven.
3. Mount external air duct on stacking spacer as shown below. External air duct must be installed for cooling system of top unit to function properly.
4. Screw cap screws (Qty 4) into leg hold on the top oven.
5. Place top oven on stacking spacer. Cap screws will set into cut out in top of stacking spacer to lock unit into position.

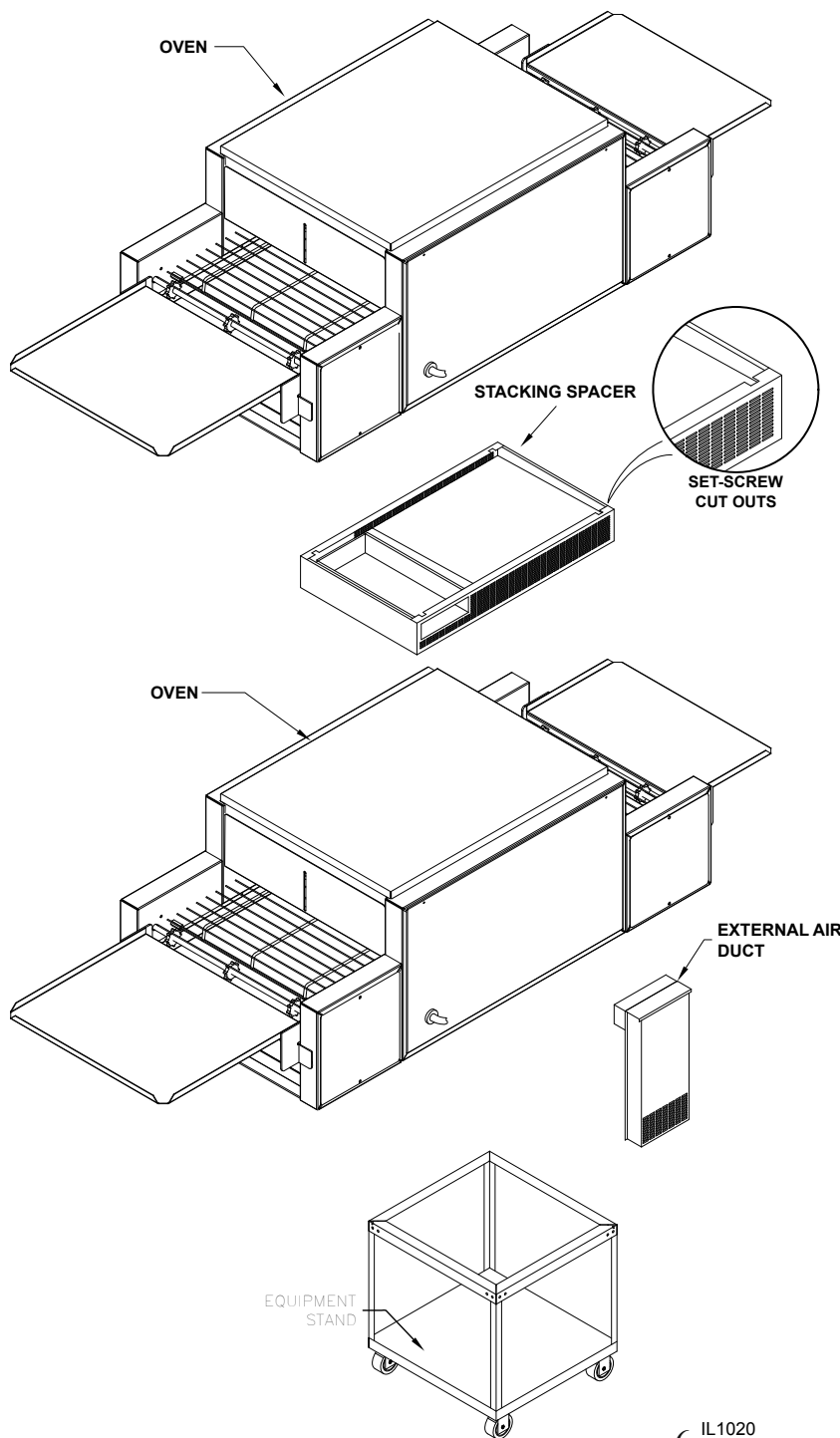

NOTE: Air intake of top unit must fit over the internal air duct of stacking spacer to allow airflow into the control box of the top oven.

TOP UNIT: cap screw, screws into leg holes, unit sits on top of spacer.

STACKING SPACER: (REQUIRED) Sits on top of bottom oven.

EXTERNAL AIR DUCT: Mounts onto spacer, pointing downward.

BOTTOM UNIT: Can be placed on a counter or mounted on cart as shown.

Cart: Mounting bolts for bottom unit screw into leg holes through the top cart frame.

DAILY OPERATION

Baking in these units is a combination of heat and belt speed. Some foods may require more top heat or visa versa; other foods may require low top and bottom heat and slow belt speeds. Every product should, therefore, be tested using the separate top & bottom controls and the variable speed control to arrive at the correct balance of heat and belt speed. When changing heat and or belt speed setting allow approx. 5 minutes for the oven to stabilize itself at the new settings.

Check the power cord to insure that it is plugged into a proper outlet.

Always allow 10 to 15 minutes of preheat time before loading the unit with product. Failure to allow sufficient preheat time will result in unsatisfactory cooking until the unit reaches operating temperature.

- 1) Turn the master on/off switch to the ON position.
- 2) Set both the top and bottom heat controls to 500°F (260°C).
3-Phase Control Units, set front heat controls to 500°F (260°C)
- 3) Turn conveyor speed control to the fastest setting.
- 4) Allow 10 to 15 minutes for initial warm up,
(5 to 8 minutes to reach adjusted temperature, once unit is fully warmed up)



CERTAIN SURFACES ARE EXTREMELY HOT DURING OPERATION AND CARE SHOULD BE TAKEN WHILE USING THIS UNIT.

OVEN COMPONENTS

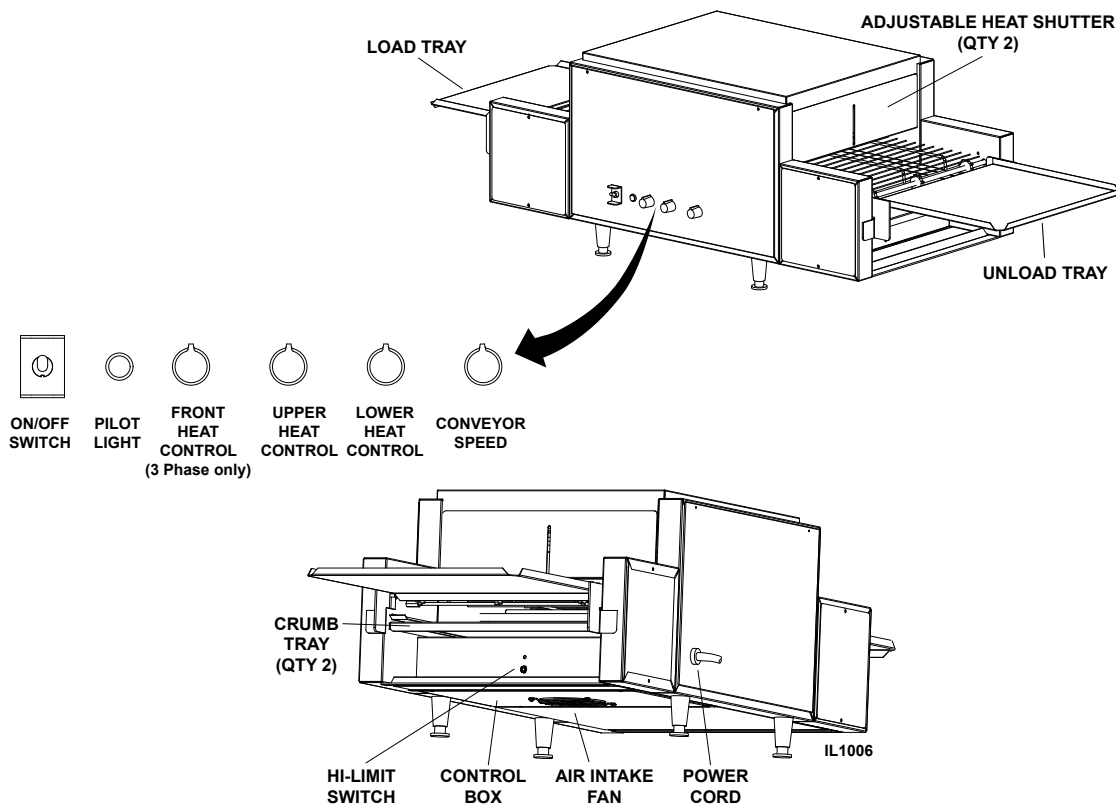

OPERATING HINTS AND SAFETY

Disconnect power to the unit with the switch at the end of each day of operation.

Do not leave the unit in operation without an attendant.

Do not leave the unit at high temperature when not in use or during idle periods. This will cause food particles and grease film to carbonize. It will take only a few minutes to regain operating temperature.

CLEANING

Preventive maintenance for your Holman Oven consists of the following recommended cleaning procedures. To keep your oven in its top operating condition, these steps should be performed on a daily, weekly or as indicated.



WARNING BREAKER.

DISCONNECT UNIT FROM POWER SUPPLY OR TURN POWER OFF AT WALL

DAILY

1. Turn main power switch to the OFF position. Disconnect unit from power source and allow to cool.
2. Using a mild detergent, wipe exterior surfaces, clean with a damp cloth.
 - a. For lightly soiled build-up, clean with a damp cloth.
 - b. For heavily soiled build-up, use an soft damp cloth and mild detergent.**DO NOT use caustic cleaners.**
3. Remove the load & unload tray by lifting them out of position. Clean using mild detergent and warm water.
4. Remove each crumb tray by sliding each of them out from under the conveyor belt. Clean crumb trays by wiping with a damp cloth and mild detergent.**DO NOT use caustic cleaners.** Place trays back in place prior to putting unit back into operation.
5. Reconnect power.



CAUTION

WEEKLY

1. Turn main Power switch to the OFF position. Disconnect unit from power source and allow to cool.
2. Perform daily cleaning procedures.
3. Using a damp cloth, wipe clean the fan guard located on the control box cover under the unit.

CLEAN CONVEYOR BELT

4. Reconnect power or turn power back on.
5. Switch the ON/OFF switch to the ON position, and turn Conveyor to its fastest setting.
6. With the Conveyor turned on and the crumb trays in place, take a wire grill brush or dry abrasive pad, clean the exposed surface of Conveyor Belt by passing the brush or pad, back and forth across the surface of the Conveyor Belt as the belt moves past. Continue until the entire belt is clean. Make sure the Crumb Tray is installed, this will minimize the amount of particles that fall into the oven.
7. When the Conveyor Belt is clean, take a damp cloth and wipe the conveyor, removing any loose particles on the belt surface. Turn Conveyor OFF.
8. Remove the Crumb Trays by sliding out from beneath the conveyor belt. Clean the Crumb Trays by wiping with a damp cloth and mild detergent.**DO NOT use caustic cleaners.**
DO NOT RUN CONVEYOR OVEN WITHOUT CRUMB TRAYS INSTALLED.

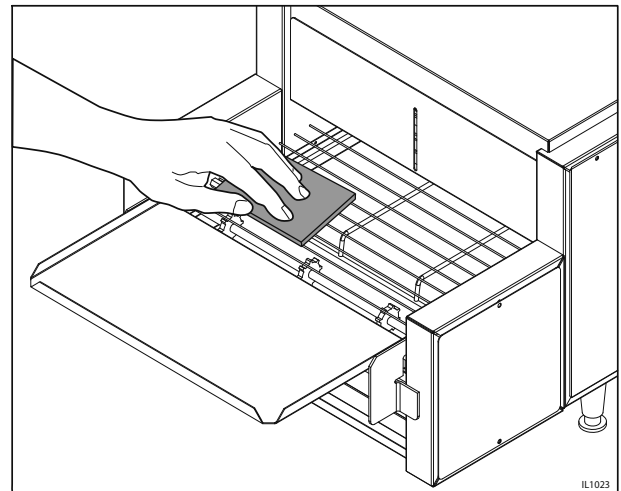

CLEANING CONVEYOR BELT

DO NOT IMMERSE OR LET THE UNIT STAND IN WATER.

DO NOT HOSE DOWN THE UNIT OR THE TABLE/COUNTER IF THE UNIT IS ON THE TABLE/COUNTER.



WARNING

KEEP AWAY FROM RUNNING WATER.

CLEANING CONTINUED

MONTHLY

1. Turn main power switch to the OFF position. Disconnect unit from power source and allow to cool.
2. Perform daily & weekly cleaning procedures.

REMOVAL & CLEANING CONVEYOR BELT

3. Heavily soiled conveyor surfaces, locate the Master Links on the conveyor belt. Follow the step 1 in Fig 1, to remove all of the Master Links. 314 models have 3 master links, 318 models have 4 master links.
4. Now that the links have been un-hooked, the conveyor can now be carefully removed from the oven. Standing at one end of the oven. Starting with the end on the bottom, roll the conveyor belt until it has been totally removed. Take careful notice being sure not to damage the heater tubes.
5. Clean conveyor belt in deep sink, caustic cleaners may be used. For a heavy soiled conveyor belt, soak over night in hot soapy water.

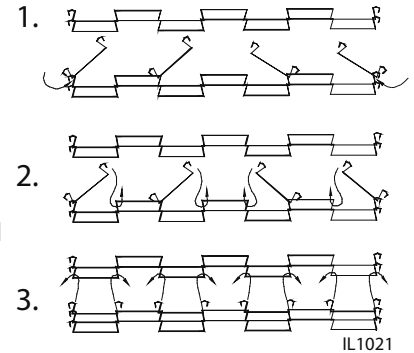

NOTE: DO NOT ATTEMPT TO CLEAN THE HEATER TUBES.

6. Take this opportunity to clean and remove any loose materials inside the unit. Using a mild cleaner and damp cloth, carefully wipe the inside surfaces being sure NOT to clean the heater tubes. **DAMAGE CAN OCCUR TO THE HEATER TUBES FROM IMPROPER CLEANING.**

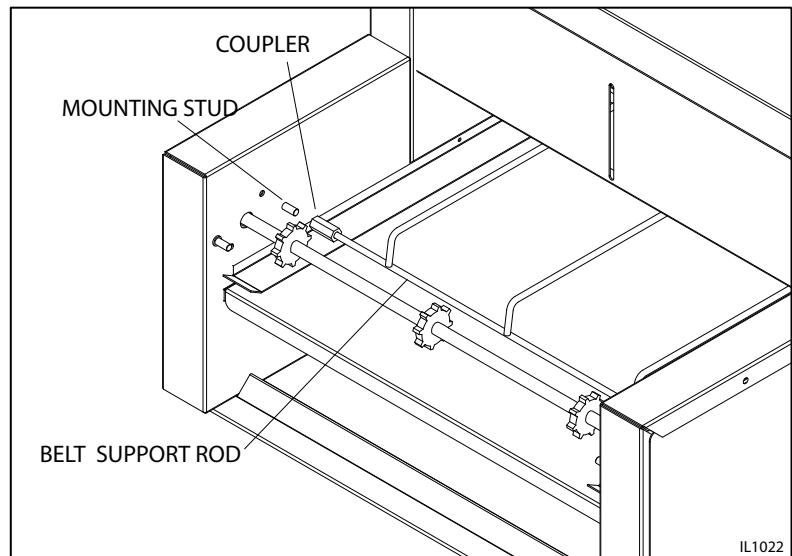

DO NOT SPRAY CLEANING SOLUTIONS INTO OVEN CAVITY.

7. Remove the conveyor support system as shown in Fig 2. by removing the Couplers from the mounting Studs. Clean by warm water and abrasive pad.
8. Reinstall the conveyor support system.
9. Reinstall conveyor belt by first laying the belt along the bottom of the oven cavity making sure the hooks on the sides are facing the inside and the ends of the hooks will be pointing away from the direction of the belt so not to catch on any internal components once put back into operation.

NOTE: THE DIRECTION OF THE BELT.

10. Next, pull one end of the conveyor belt over the top of the sprockets, (being sure to line the links up properly with the sprockets) bringing the two ends together.
11. Reinstall the previously removed master links as shown in steps 2 & 3 in Fig. 1.
12. Examine the oven to assure proper installation, once satisfied, install crumb trays if you have not done so.
13. Reconnect oven to power supply and check for proper operation.

IF ASSISTANCE IS REQUIRED, CALL THE STAR SERVICE TEAM AT (314) 634-6303.

MAINTENANCE PROCEDURES

A. REPLACING HEATER TUBES

- 1) DISCONNECT POWER SOURCE.
- 2) Remove both the left and right side panels, by removing the truss head screws. Pull the top of each panel out slightly and lift up.
- 3) Remove heater tube wires which are requiring replacement from its terminal block connection.
- 4) Remove heater tube retainer by removing retainer screws with washer.
- 5) Gently, pull defective heater tube out of unit.
- 6) Gently, put new heater tube into unit.
- 7) Replace heater tube retainers.
- 8) Reconnect the heater tube wires to the terminal block.
- 9) Install each side panel
- 10) Connect unit to power source and test unit for proper operation.

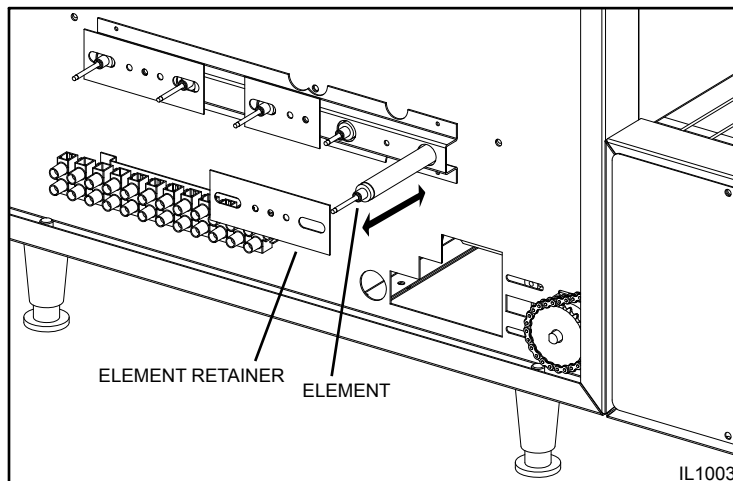

B. REPLACING FAN MOTOR

- 1) DISCONNECT POWER SOURCE.
- 2) After unit has cooled, remove the load & unload trays, and turn unit over so the bottom is facing upward.
- 3) Remove the control box cover which contains the fan motor, by removing the screws.
- 4) Unplug power supply cord from fan motor.
- 5) Remove (4) screws, which hold fan motor and grill to the control box cover and remove fan.
- 6) Once removed, clean grill and control box cover using warm soapy water.
- 7) Put replacement motor and grill in place and secure to the control box cover with screws previously removed.
- 8) Reconnect power supply cord to fan motor.
- 9) Replace back panel and enclosure. Fasten with screws removed in step 3.
- 10) Connect unit to power source and test unit for proper operation.

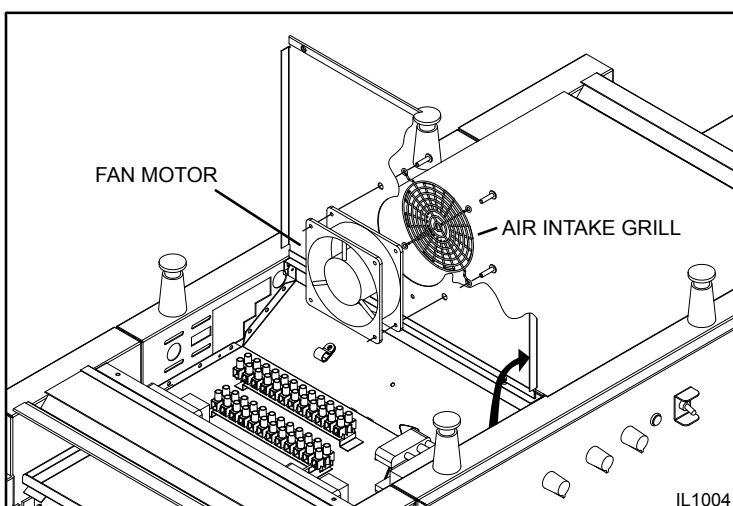

C. REPLACING BELT DRIVE MOTOR

- 1) DISCONNECT POWER SOURCE.
- 2) After unit has cooled, remove the load & unload trays, and turn unit over so the bottom is facing upward.
- 3) Remove the control box cover which contains the fan motor, by removing the (4) screws.
- 4) Remove the side panel that will expose the drive chain and sprockets.
- 5) Remove sprocket from motor shaft, using an Allen wrench and loosening the set-screw.
- 6) Remove the wire from terminal block connecting the drive motor to the internal wiring. On units rated 208 or 240 volts, note which color leads are being used for these connections and which lead is capped with glass tape. The new motor should use the same arrangement.
- 7) Remove screws holding motor in place and remove motor from unit.
- 8) Put new motor in place and attach loosely with mounting screws.
- 9) Replace sprocket on motor shaft.

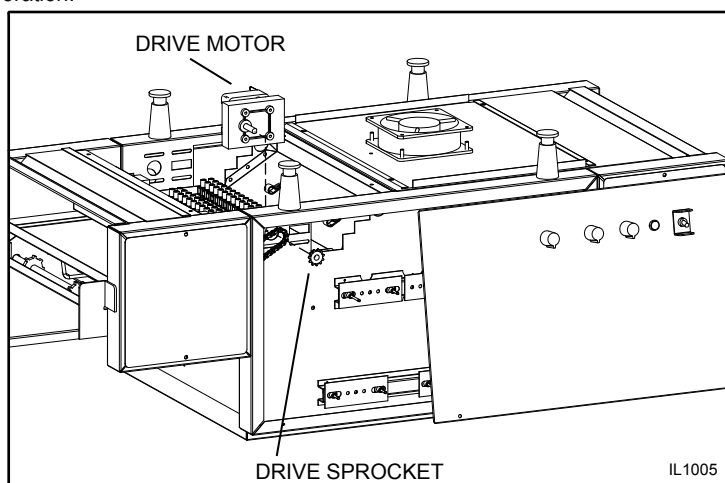

NOTE: The two sprockets must line up FLUSH with each other, so the chain does not twist any during operation. Also the hub gets installed closets to the motor.

MAINTENANCE PROCEDURES continued

- 10) Slide motor until the drive chain has about 1/4" slack when lightly pushed at the center of its top open run.
See chain tensioning illustration.
- 11) Tighten screws to secure motor.
- 12) Rewire leads same as removed in step 6.
- 13) At this time you may plug unit in and test for proper operation prior to reinstalling panels and turning unit back over onto its feet.
- 14) If unit is working correctly, turn unit off and unplug until completed.
- 15) Reinstall side panels and control box cover.
Place unit back into its upright position.
Reinstall the load & unload trays.
- 16) Connect unit to power source and test unit for proper operation.

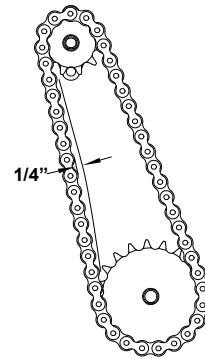

Chain Tension

D. REPLACING SPEED CONTROL

- 1) DISCONNECT POWER SOURCE.
- 2) Remove the speed control knob and the locking nut holding the speed control in place.
- 3) Remove right side panel, by removing the truss head screws. Pull the top of the panel out slightly and lift up.
- 4) Wires from the speed control go into a terminal block located on the side of the chassis. Remove the wires from the control and insert wires for the new speed control into the same positions as shown on the wiring diagram.
- 5) Install the washer onto the shaft of the speed control, followed by the installation.
- 6) When mounting the speed control in the side panel be sure to position the anti-rotation pin in the slot as shown.
- 7) Tighten the speed control assembly by using the locking nut, followed by the control knob.
- 8) Reinstall the side panel and tighten with the screws previously removed.

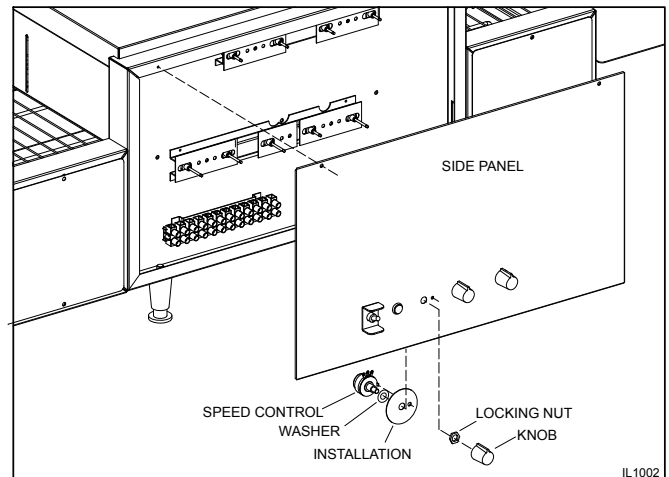

E. CLEANING AIR INTAKE ONCE A WEEK.

- 1) DISCONNECT UNIT FROM POWER SOURCE.
- 2) Place unit on its backside.
- 3) Use a vacuum cleaner and or a damp cloth to clean the air intake.
This procedure should be done at least once a week.

F. LUBRICATE THE CHAIN & SPROCKETS EVERY 6 MONTHS

- 1) DISCONNECT UNIT FROM POWER SOURCE.
- 2) Remove the side panels which exposes chain drive.
- 3) Using an extreme pressure, synthetic chain lubricant with a temperature range up to 400°F. Apply liberally onto chain and sprockets.
This grease is available separately as part no. 1P-Z8914. Call 1-(800) 807-9054 to order.
- 4) Replace side panels, Reconnect power source and test unit.

TROUBLESHOOTING GUIDE

A. UNIT WILL NOT HEAT, CONVEYOR BELT WILL NOT MOVE.

- 1) Be sure the main circuit breaker is switched to the ON position and there is power to the outlet.
- 2) Check to see if the oven is plugged in and all controls are turned to the ON position.
- 3) Be sure the Hi-Limit Reset Button is pushed in.
- 4) Call the Star Service Help Desk at (314) 634-6303.

B. UNIT WILL NOT HEAT, CONVEYOR TURNS PROPERLY.

- 1) Check to see if the top and bottom heat controls have been turned to the maximum setting.
- 2) Press the Hi-Limit Reset Button located underneath the conveyor belt on the right side. If this reactivates the heater tubes, see Hi-Limit Reset Section below.
- 3) Call the Star Service Help Desk at (314) 634-6303.

C. HI-LIMIT (HEAT) RESET.

Your Holman conveyor oven is equipped with an automatic activated temperature limit switch which interrupts the heater tube connections if the air temperature in the control box exceeds 190°F (88°C) This limit switch can be reset manually by pushing the button in the center of the switch which is located on the right side under the conveyor belt. See Oven Components on Page 7 for location. Unit will not reset until internal temperature has fallen below 190°F (88°C).

NOTE: THE HI-LIMIT SWITCH CAN BE ACTIVATED IF THERE IS NOT A PROPER AMOUNT OF AIR FLOW BEING GENERATED BY THE COOLING FAN. IF THIS OCCURS:

- 1) DISCONNECT UNIT FROM POWER SOURCE.
- 2) Check to see if the air intake area (center of the control box, bottom of unit) is free of dust, grease or other obstructions.
- 3) Check to see if crumb trays (heat reflectors) are in place. If the Hi-Limit Switch can not be reset, call the Star Service Help Desk at (314) 634-6303.



NEVER OPERATE UNIT WITHOUT CRUMB TRAYS IN POSITION AS THIS CAUSES

CAUTION OVERHEATING IN THE CONTROL BOX.

D. CONVEYOR WILL NOT TURN, UNIT HEATS PROPERLY.

To check for mechanical binding:

- 1) **DISCONNECT UNIT FROM POWER SOURCE.**
- 2) Check to see if there are obstructions in the conveyor system that may cause a jam. If so, remove obstruction.
- 3) Check power supply & terminal blocks for loose or disconnected wires.
- 4) Remove right side panel and drive motor sprockets, see illustration. Manually move conveyor belt to check for mechanical binding. If conveyor belt moves freely, call the Star Service Help Desk at (314) 634-6303. The drive motor or speed control may have to be replaced.

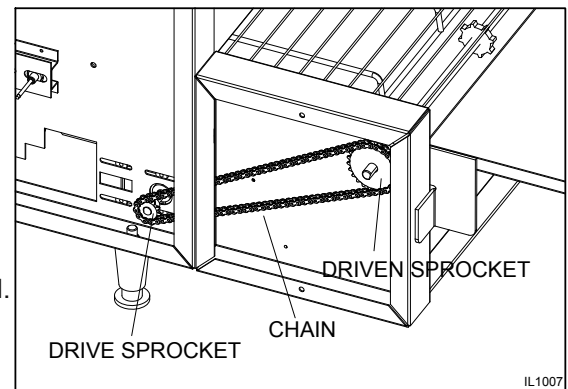

E. CONVEYOR TURNS AT ONE SPEED REGARDLESS OF SPEED CONTROL SETTING.

- 1) Call the Star Service Help Desk at (314) 634-6303, as speed control **MAY** need replacing. Refer to **REPLACING SPEED CONTROL** in the previous section.

F. COOLING FAN DOES NOT START

- 1) Remove control box cover and check fan blade for obstruction.
- 2) Check electrical connections are secure and complete.
- 3) Call the Star Service Help Desk at (314) 634-6303, as the fan switch and or fan motor **MAY** need replacing. Refer to **REPLACING FAN MOTOR** in the previous section.

LIMITED EQUIPMENT WARRANTY

Star Manufacturing [as well as its subsidiaries, Toastmaster and Holman] warranties new products to be free from defects in material and/or workmanship for a period of one [1] year from the date of original installation, except as noted below. Defects that occur as a result of normal use, within the time period and limitations defined in this warranty, will at Star’s discretion have the parts replaced or repaired by Star or a Star-authorized service agency.

THIS WARRANTY IS SUBJECT TO ALL LISTED CONDITIONS.

Repairs performed under this warranty are to be performed by a Star authorized service agency. Star will not be responsible for charges incurred or service performed by non-authorized repair agencies. In all cases, the nearest Star-authorized service agency must be used. Star will be responsible for normal labor charges incurred in the repair or replacement of a warranted product within 50 miles (80.5 km) of an authorized service agency. Time and expense charges for anything beyond that distance will be the responsibility of the owner. All labor will need to be performed during regular service hours. Any overtime premium will be charged to the owner. For all shipments outside the U.S.A. and Canada, please see the International Warranty for specific details. It is the responsibility of the owner to inspect and report any shipping damage claims, hidden or otherwise, promptly following delivery. No mileage or travel charges will be honored on any equipment that is deemed portable. In general, equipment with a cord and plug weighing less than 50 lb. (22.7 kg) is considered portable and should be taken or shipped to the closest authorized service agency, transportation prepaid.

PORTABLE EQUIPMENT EXAMPLES

- 514LL fryer
- 15MC and 18MCP hot food merchandisers
- QCS1, QCS2, and RCS2 toasters
- 16PD-A pretzel merchandisers
- Condiment dispensers except HPD- and SPD-series models
- All pop-up toasters
- All pastry display cabinets
- All heat lamps
- J4R popcorn machine
- 12NCPW and 15NCPW nacho merchandisers
- Nacho cheese warmers except 11WLA-series models
- Specialty food warmers except 130R, 11RW, and 11WSA models
- All butter dispensers
- All nacho chip merchandisers
- All accessories

CONTACT

Should you require any assistance regarding the operation or maintenance of any Star equipment; write, phone, fax or email our service department. In all correspondence mention the model number and serial number of your unit, as well as the voltage or type of gas you are using. Business hours are 8:00 a.m. to 4:30 p.m. Central Standard Time (CST)
 Telephone: (800)-264-7827
 Fax: (314)-781-2714
 Email: Customerservice@star-mfg.com
www.star-mfg.com

WARRANTY EXCLUSIONS

THE FOLLOWING WILL NOT BE COVERED UNDER WARRANTY.

- Any product which has not been used, cleaned, maintained, or installed in accordance with the directions published in the appropriate installation sheet and/ or owner’s manual as well as national and local codes, including incorrect gas, electrical, or water connection. Star is not liable for any unit which has been mishandled, abused, misapplied, subjected to chlorides, harsh chemicals, or caustic cleaners, damaged from exposure to hard water, modified by unauthorized personnel, damaged by flood, fire, or other acts of nature [or God], or which have an altered or missing serial number.
- Installation, labor, and job checkouts, calibration of heat controls, air and gas burner/bypass/pilot adjustments, gas or electrical system checks, voltage and phase conversions, cleaning of equipment, or seasoning of griddle surface.
- Replacement of fuses or resetting of circuit breakers, safety controls, or reset buttons.
- Replacement of broken or damaged glass components, quartz heating elements, and light bulbs.
- Labor charges for all removable parts in gas charbroilers and hotplates, including but not limited to burners, grates, and radiants.
- Any labor charges incurred by delays, waiting time, or operating restrictions that hinder a service technician’s ability to perform service.
- Replacement of items subject to normal wear or items that can easily be replaced during a daily cleaning routine, such as but not limited to knobs, bulbs, fuses, quartz heating elements, baskets, racks, and grease drawers.
- Components that should be replaced when damaged or worn, but have been field-repaired instead [eg. field-welded fry pots]
- Any loss of business or profits.

PRODUCTS	PARTS	LABOR
Star-Ultra Max® fryers, griddles, charbroilers, and hotplates	2 years	2 years
Star-Max® fryers, griddles, charbroilers, and hotplates	2 years	2 years
Jetstar® popcorn poppers	2 years	2 years
Staltek™ roller grill coatings	5 years	
Cast iron grates, burners; and burner shields	180 days	
Star, Toastmaster, or Holman parts sold to repair equipment	90 days	
Service First	1 year	

- S1 SWITCH, MAIN
- S2 SWITCH, HIGH LIMIT RESET
- S3 SWITCH, FAN COOLDOWN
- M1 MOTOR, CONVEYOR
- M2 MOTOR, FAN
- SC SPEED CONTROL
- P PILOT LIGHT
- TCF TEMP CONTROL - FRONT
- TCT TEMP CONTROL - TOP
- TCB TEMP CONTROL - BOTTOM

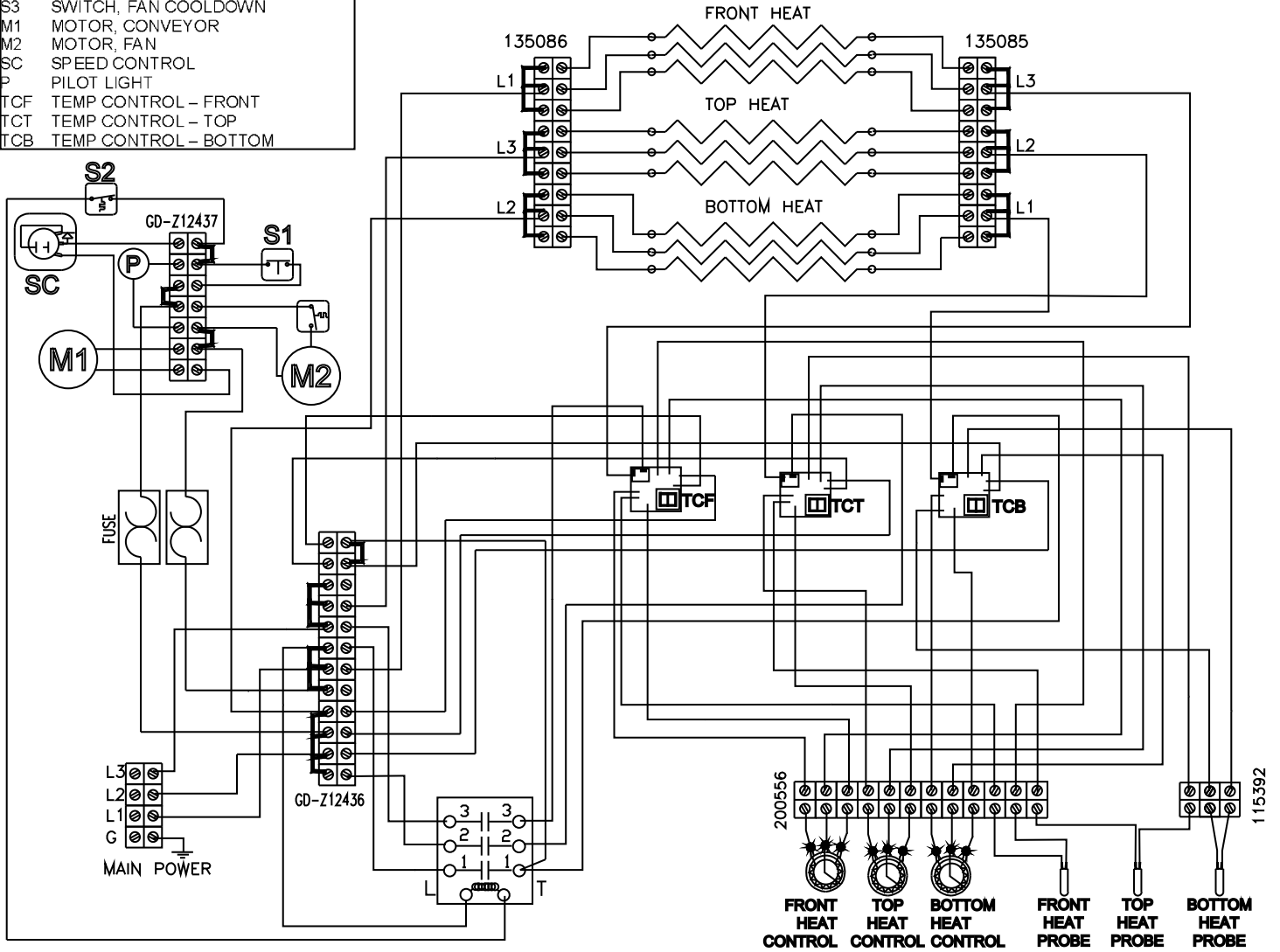

THIS DRAWING CONTAINS INFORMATION CONFIDENTIAL TO STAR MFG. INT'L. INC.
 NO REPRODUCTION OR DISCLOSURE OF ITS CONTENTS IS PERMITTED.

MODEL: 314HX, 318HX, 208/240V, 3 PHASE, DELTA CONF



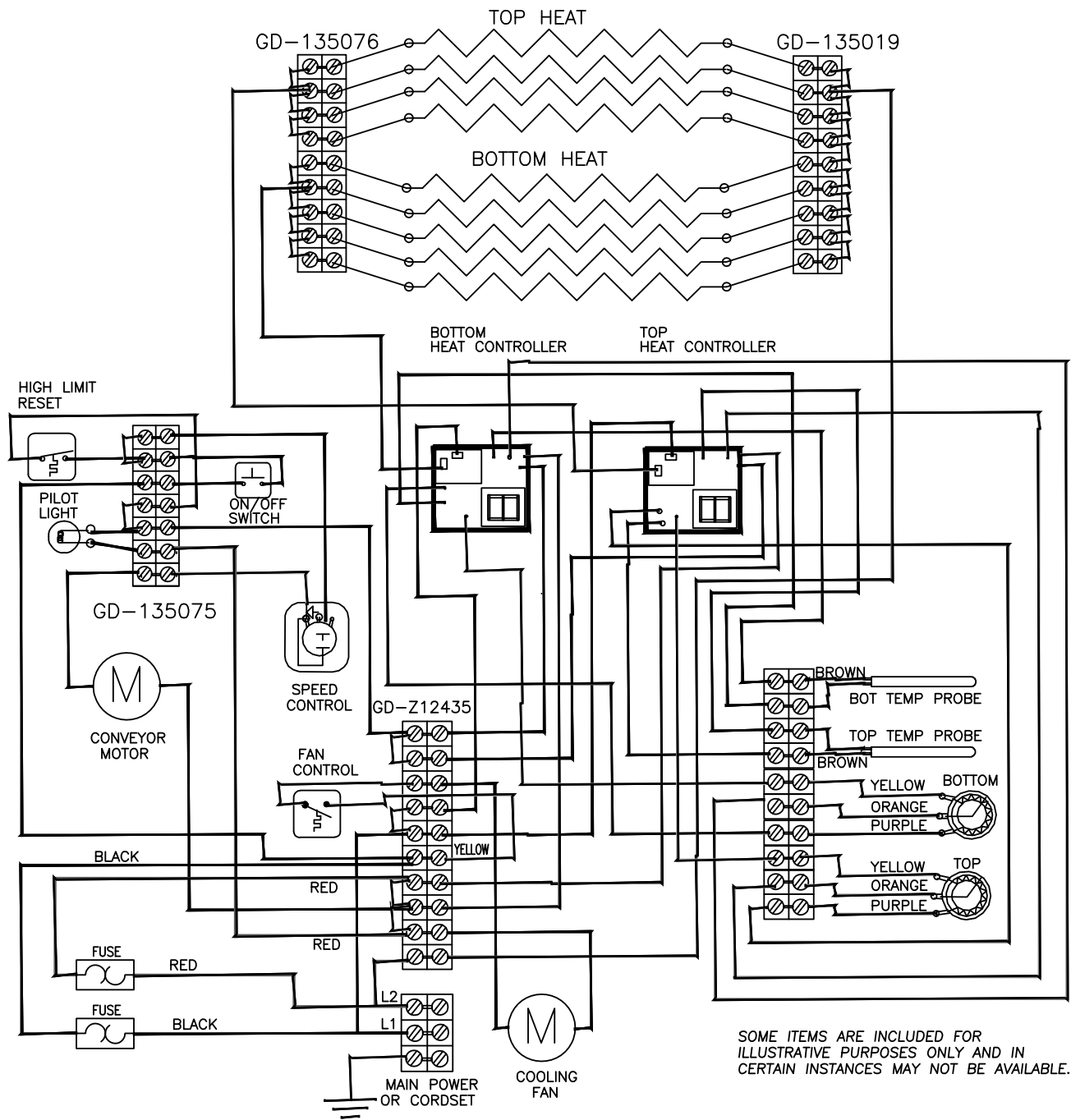

SOME ITEMS ARE INCLUDED FOR ILLUSTRATIVE PURPOSES ONLY AND IN CERTAIN INSTANCES MAY NOT BE AVAILABLE.

THIS DRAWING CONTAINS INFORMATION CONFIDENTIAL TO STAR MFG. INT'L. INC.
NO REPRODUCTION OR DISCLOSURE OF ITS CONTENTS IS PERMITTED.



MODEL: 314HX, 318HX, 208/240V, SINGLE PHASE

SINGLE PHASE
PHASE CONTROL

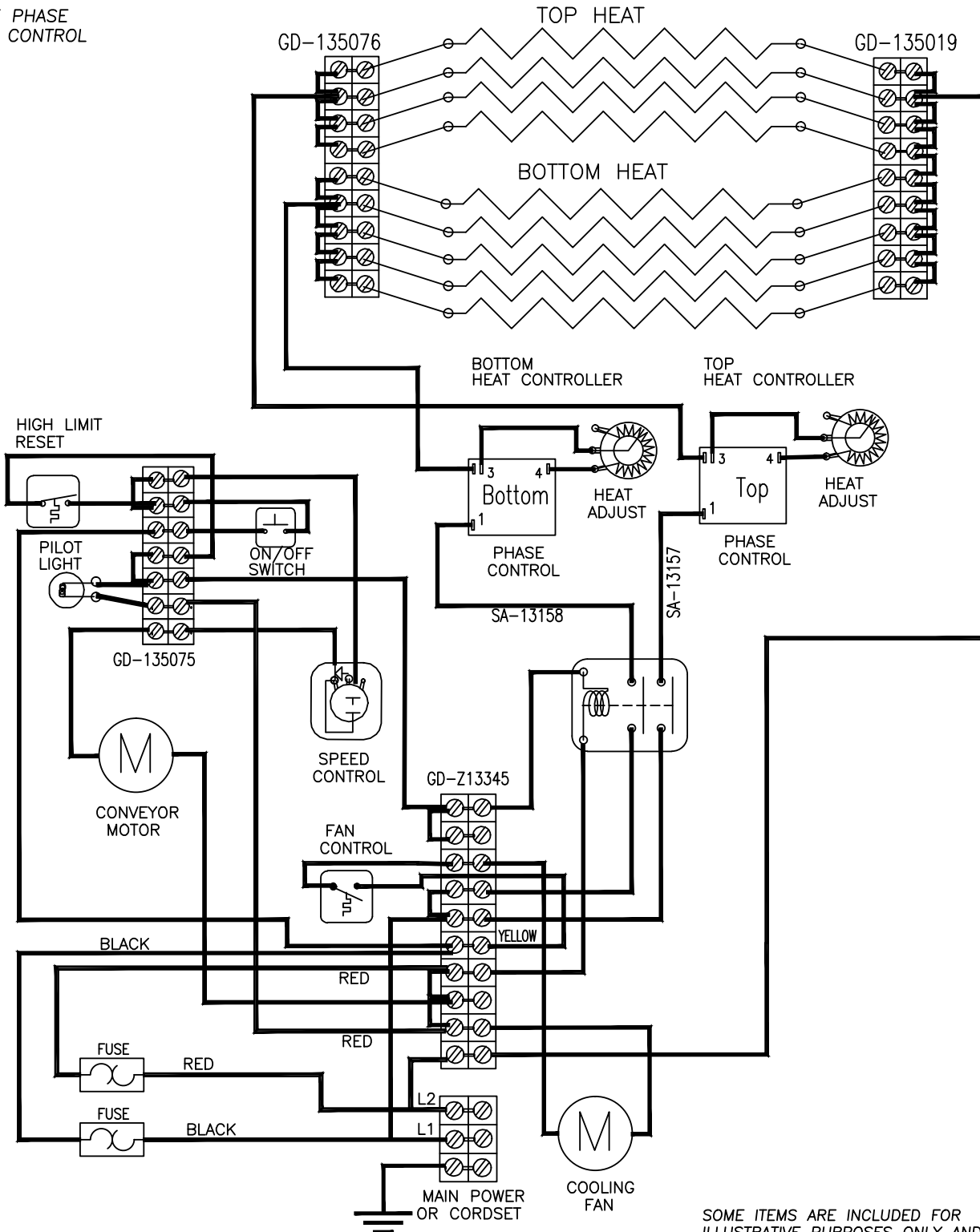

SOME ITEMS ARE INCLUDED FOR ILLUSTRATIVE PURPOSES ONLY AND IN CERTAIN INSTANCES MAY NOT BE AVAILABLE.

THIS DRAWING CONTAINS INFORMATION CONFIDENTIAL TO STAR MFG. INT'L. INC.
NO REPRODUCTION OR DISCLOSURE OF ITS CONTENTS IS PERMITTED.

MODEL: 314HX, 318HX, 208/220/240 VOLT, 60 Hz
SINGLE PHASE (PHASE CONTROLS)



020078

Rev - 05/2/2000

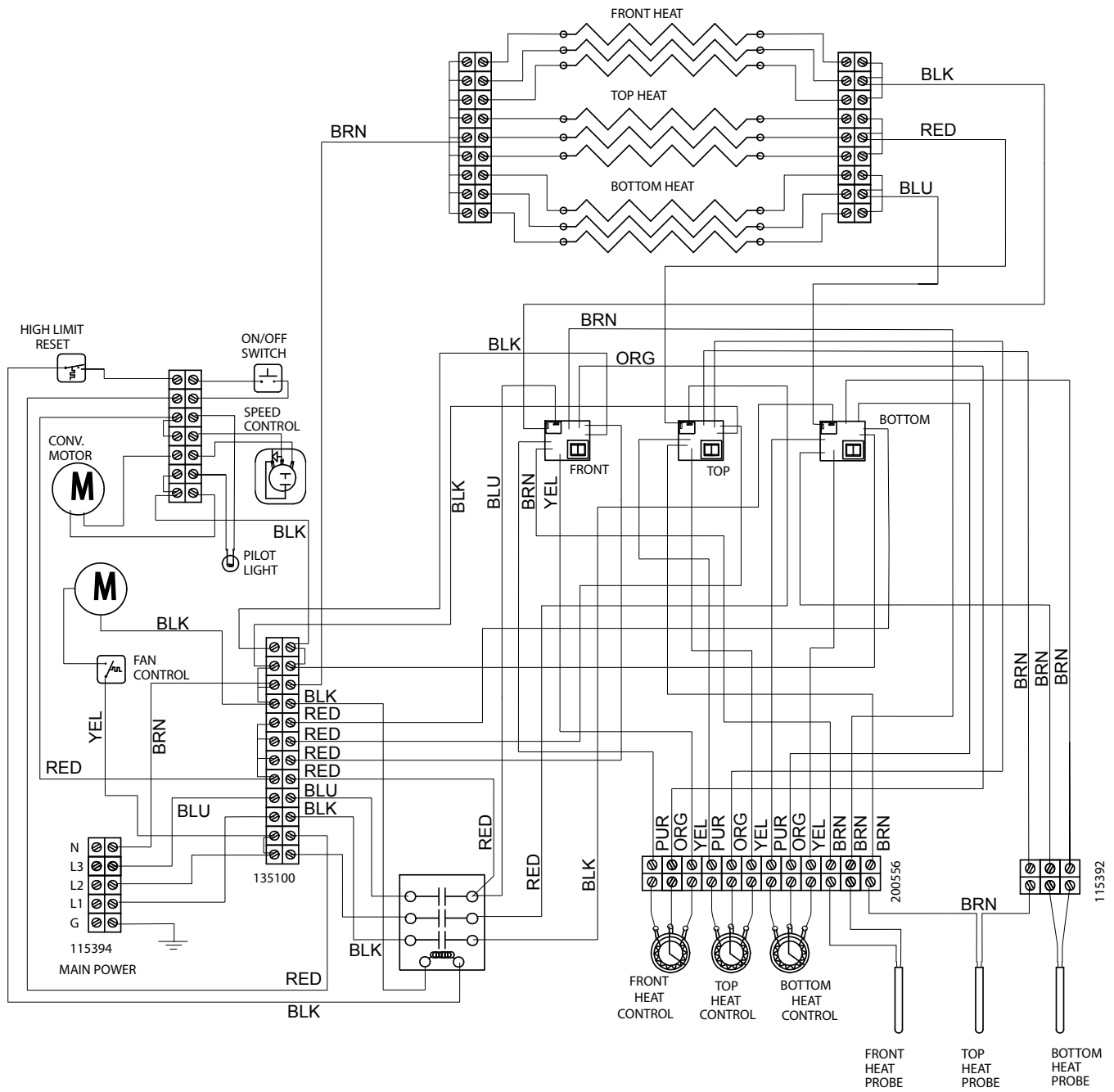

THIS DRAWING CONTAINS INFORMATION CONFIDENTIAL TO STAR MFG. INT'L. INC.
 NO REPRODUCTION OR DISCLOSURE OF ITS CONTENTS IS PERMITTED.

**MODEL: 314HX, 318HX, THREE PHASE WYE CONF.
 (STRATFORD CONTROLS)**



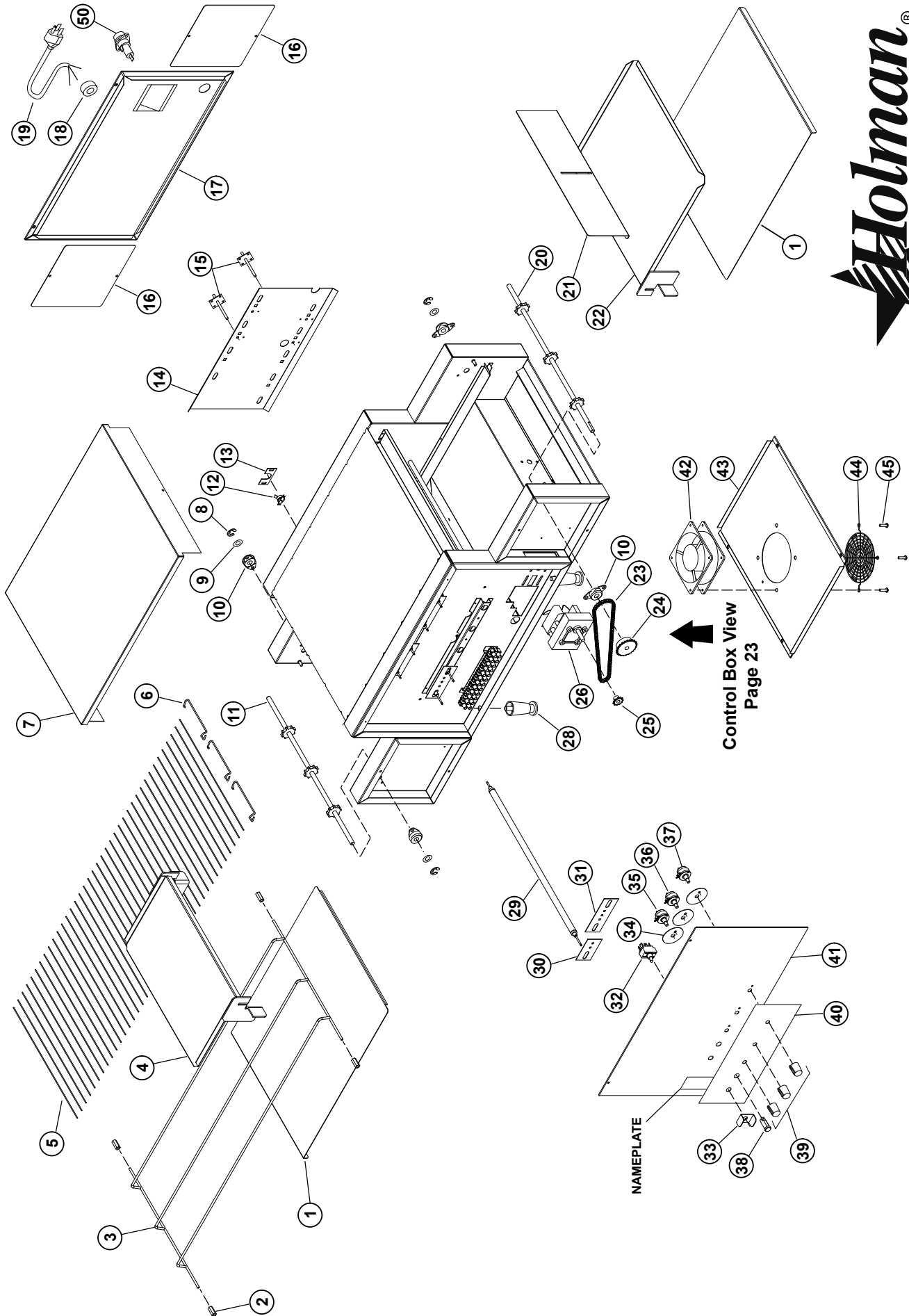

MODEL: PROVEYOR
314HX, 318HX, 418HX



314HX Series Holman Conveyor Oven

Fig No	Part No	Qty	Description	App.
1	GD-401227	2	TRAY, CRUMB	
2	2A-200672	4	COLLAR, SHAFT	
3	GD-100707	1	RACK, BELT SUPPORT SYSTEM	
4	GD-100403	1	TRAY, LOAD-UP	
5	GD-160008	1	CONVEYOR BELT (14" X 75")	
6	2B-200626	3	LINK, MASTER, CONVEYOR BELT	
7	GD-401168	1	COVER, TOP	
8	2A-200284	3	E-CLIP	
9	2C-200149	3	WASHER	
10	GB-112262	4	BUSHING 3/8"	
11	GD-101253	1	SHAFT, IDLER (3/8")	
12	2E-200574	1	SWITCH, FAN MOTOR	
13	HG-402144	1	FAN SWITCH BRACKET	
14	GD-401238	1	RETAINER, HEATER TUBE RIGHT	
15	2J-200568	2	PROBE, HEAT (Straiford Control Model)	3 Phase
		3		
16	GD-401206	4	COVER, EXTENSION SIDE	
17	GD-101488	1	PANEL ASSY, PLUG SIDE (L-R MODEL)	
	GD-101489	1	PANEL ASSY, PLUG SIDE (R-L MODEL)	
18	2K-200458	1	BUSHING, POWER SUPPLY CORD	
19	GD-Z11260	1	CORSET 10-3 W/6-50P, 50A, Ser No on/after CO3181009A0001	314HX
	2E-200383	1	CORD/PLUG SEET, 10GA, 30A, Ser No Before CO3181009A0001	
20	GD-101252	1	SHAFT, DRIVE (3/8")	
21	GD-401233	2	SHUTTER, HEAT	
22	GD-101403	1	TRAY, UNLOAD	
23	2P-150023	1	DRIVE CHAIN (27")	
	2P-200654	1	SPROCKET, DRIVEN (25B24 X 3/8")	
24	2P-115362	1	SPROCKET, DRIVEN (25B11 X 3/8")	314HXRD, HXRRD
		1	SPROCKET, DRIVE (25B11 X 5/16")	
25	2P-200650	1	SPROCKET, DRIVE (25B24 X 5/16")	314HXRD, HXRRD
		1	MOTOR, DRIVE (L-R), CCW	
26	2U-Z11871	1	MOTOR, DRIVE (R-L), CW	208/240V
	2U-Z11870	1	BLADE, FAN, DRIVE MOTOR	
27	2R-200721	1		208/240V

Fig No	Part No	Qty	Description	App.
28	2R-200716	4	LEG, 2 1/2" METAL	
	GD-197888		HTERTUBE, QRTZ; 208V, 613W, 67.9 ohm	208V
	GD-197893		HTERTUBE, QRTZ; 220V, 600W, 78.7 ohm	220V
	GD-197889		HTERTUBE, QRTZ; 240V, 600W, 90 ohm	240V
29	2N-209201	9	ELEMENT, METAL, 600W, 208V 1	208V
	2N-209203		ELEMENT, METAL, 600W, 240V, 1	
30	GD-402446	1	RETAINER, SINGLE HTERTUBE, QUARTZ	314HXTA, 314HXTAR
	GD-401238		RETAINER, SINGLE HTERTUBE, METAL	
31	GD-401232	4	RETAINER, DUAL HTERTUBES, QUARTZ	
	GG-401989		RETAINER, HEATERTUBES, METAL	
32	2E-200564	1	SWITCH, ON/OFF TOGGLE	314HX
33	2P-401780	1	GUARD, TOGGLE	
34	2E-200180	3	INSULATION, SWITCH, POT.	
35	2J-200567	1	SWT, FRONT HEAT CNTRL POT., 3Ph Straiford	3 Phase, Straiford
	2J-200567	1	SWT, TOP HEAT CNTRL POT. Straiford	
36	GD-115350	1	SWITCH, CNTRL HEAT ASSY TOP, Phase Cntrl	
	2J-200567	1	SWITCH, BTM HEAT CNTRL POT. Strat	
37	GD-115351	1	SWITCH, CNTRL HEAT ASSY BTM, Phase	314HX
	GB-118062	1	SWITCH, SPEED CNTRL ASSY (10000)	
38	2J-200427	1	PILOT LIGHT	
	2R-200708	3	CAP, KNOB CONTROL	
39	2R-200768	3	KNOB, HEAT CONTROL, SPEED	3 Phase
	2R-200768	4	CONTROL	
40	2M-200866	1	LABEL 3 PHASE HX CONTROL LABEL	3 Phase
	2M-200872	1	LABEL, CONTROL PANEL	
41	GD-401375	1	PANEL, CONTROL SIDE	3 Phase
	GD-401540	1	MOTOR, FAN	
42	2U-200561	1	COVER, CONTROL BOX	
43	HT-401496	1	GRILL, FAN MOTOR	
44	2R-200562	1	SCREW, 10-24 X 1/2 FZA, SELF DRILLING	
45	2C-Z5883	4		



314HX Series Holman Conveyor Oven

Fig No	Part No	Qty	Description	App.
46	2J-200569	2	CONTROL, HEAT (Stratford Control)	
		3	CONTROL, HEAT (3 PHASE)	3 Phase
47	SP-115146	1	SWITCH, HIGH LIMIT RESET	
	SP-115338	2		120V
48	SP-115339	3	CONTROL, HEAT (Phase Control)	3 Phase
49	2E-200529	1	CONTACTOR 3PH	3 Phase
	2E-Z8966		CONTACTOR, 50AMP 208/240V 1PH	1 Phase
50	2E-30901-08	2	FUSE HLDR FOR SC FUSE	
NI	2E-Z5680	2	FUSE, 5A - CLASS G	
NI	2B-200624	ea.	LINK, CONVEYOR BELT	
NI	2E-200554	~	TERMINAL BLOCK, 12 POS. LARGE	
NI	2J-200423	2	SWITCH, SPEED CONTROL (1000Ω)	
NI	GD-115392	1	TERMINAL BLCK, 3 POS. LARGE (Power Input)	
NI	GD-115396	~	TERMINAL BLOCK, 7 POS. LARGE	
NI	GD-115397	~	TERMINAL BLOCK, 8 POS. LARGE	
NI	GD-115523	~	JUMPER, 4 POS. LARGE	
NI	GD-118060	1	SPEED CONTROL,	V82, V84
NI	HM-115398	~	TERMINAL BLOCK, 9 POS. LARGE	
NI	HM-115521	~	JUMPER, 2 POS. LARGE	
NI	HM-115522	~	JUMPER, 3 POS. LARGE	
NI	1L-Z12397	1	CHAIN LUBE 1oz TUBE	



318HX Series Holman Conveyor Oven

Fig No	Part No	Qty	Description	Application
1	GF-401228	2	TRAY, CRUMB	
2	2A-200672	4	COLLAR, SHAFT	
3	GF-100709	1	RACK, BELT SUPPORT SYSTEM	
4	GF-100405	1	TRAY, LOAD-UP	
5	GF-160009	1	CONVEYOR BELT (18" X 75")	
6	2B-200621	4	LINK, MASTER, CONVEYOR BELT	
7	GF-401167	1	COVER, TOP	
8	2A-200284	3	E-CLIP	
9	2C-200149	3	WASHER	
10	GB-112262	4	BUSHING 3/8"	
11	GF-101251	1	SHAFT ASSY, IDLER	
12	2E-200574	1	SWITCH, FAN MOTOR	
13	HG-402144	1	BRACKET, FAN SWITCH	
14	GD-401238	1	RETAINER, HEATER TUBE, RIGHT	
15	2J-200568	2	PROBE, HEAT (Stratford Control Model)	3 Phase
	2J-200568	3	PROBE, HEAT (Stratford Control Model)	
16	GD-401206	4	COVER, EXTENSION SIDE	
17	GD-101488	1	PANEL ASSY, PLUG SIDE CORD SIDE (L-R MODEL)	
	GD-101489	1	PANEL ASSY, PLUG SIDE CORD SIDE (R-L MODEL)	
18	2K-200458	1	BUSHING, POWER SUPPLY CORD	
	2E-200383		**CORD, POWER SUPPLY Serial No Before CO3181107B0001	
19	GD-Z11260	1	CRDSET 10-3 W/ 6-50 PLG Ser No on/after CO3181107B0001	
	GD-Z11260		CORDSET 10-3 W/6-50 PLUG	318HXGB-208V
20	GF-101250	1	SHAFT ASSY, DRIVE	
21	GF-401289	2	SHUTTER, HEAT	
22	GF-101404	1	TRAY, UNLOAD	
23	2P-150023	1	DRIVE CHAIN (27")	
24	2P-200654	1	SPROCKET, DRIVEN (25B24 X 3/8")	
25	2P-200643	1	SPROCKET, DRIVE (25B11 X 5/16")	
26	2U-Z11871	1	MOTOR, DRIVE (L-R), CCW	Left to Right
	2U-Z11870	1	MOTOR, DRIVE (R-L), CW	Right to Left
27	2R-200721	1	BLADE, FAN, DRIVE MOTOR	
28	2R-200716	4	LEG, 2 1/2" METAL	

Fig No	Part No	Qty	Description	Application
29	2N-209205		HEATERTUBE, METAL 688W	208V
	2N-209207		HEATERTUBE, METAL 688W	240V
	GF-197885	9	HEATERTUBE QUARTZ	208V
	GF-197886		HEATERTUBE QUARTZ	240V
	GF-197891		HEATERTUBE QUARTZ	220V
30	GG-114250		HEATERTUBE, METAL 690W	208V
	GD-401238	1	RETAINER, SINGLE HEATERTUBE, METAL	
31	GD-402446	1	RETAINER, SINGLE HEATERTUBE, QUARTZ	
	GD-401232	4	RETAINER, DUAL HEATERTUBES, QUARTZ	
	GG-401989	4	RETAINER, DUAL HEATERTUBES, METAL	
32	2E-200564	1	SWITCH, ON/OFF TOGGLE	
	2E-Z1858	1	SWITCH - LIGHTED	318HXGB-208V
33	2P-401780	1	GUARD, TOGGLE	
34	2E-200180	3	SWITCH BARRIER, POT	
35	2J-200567		SWITCH, FRNT HEAT CNTRL POT., STRAT	3 Phase
	2J-200567	1	SWITCH, TOP HEAT CNTRL POT., STRAT	
36	GD-115350		CONT, HEAT ASSY 200K TOP, PHASE CNTRL	318HXGB-208V
	2J-200567		SWITCH, BOTTOM HEAT CONTROL POT.	
37	GD-115635	1	HEAT CONTROL - PARALLEL	318HXGB-208V
	GD-115351		CONT, HEAT ASSY 200K BTM, PHASE CNT	
38	GB-118062	1	SWITCH, SPEED CONTROL (1000Ω)	
	GD-Z13420		SPEED CONTROL 1kOHM	318HXGB-208V
39	2J-200427	1	PILOT LIGHT	
	2R-200708	3	CAP, KNOB CONTROL	
	2R-200708	4	CAP, KNOB CONTROL	3 Phase
	2R-200768	3	KNOB, HEAT CONTROL, SPEED CONTROL	
40	2R-200768	4	KNOB, HEAT CONTROL, SPEED CONTROL	3 Phase
	2M-200866	1	LABEL, CONTROL PANEL	3 Phase
41	2M-200872	1	LABEL, CONTROL PANEL	
42	GD-401375	1	PANEL, CONTROL SIDE	
43	2U-200561	1	MOTOR, FAN	
44	GF-402818	1	COVER, CONTROL BOX	
45	2R-200562	1	GRILL, FAN MOTOR	
46	2C-Z5883	4	SCREW, 10-24 X 1/2 FZA, SELF DRILLING	
46	SP-115347	2	CONTROL, HEAT (Stratford Control)	
	SP-115347	3	CONTROL, HEAT (Stratford Control)	3 Phase



318HX Series Holman Conveyor Oven

Fig No	Part No	Qty	Description	Application
47	2E-200566	1	SWITCH, HIGH LIMIT RESET	
48	SP-115339	2	CONTROL, HEAT (Phase Control)	
	SP-115339	3	CONTROL, HEAT (Phase Control)	3 Phase
49	2E-200529	1	CONTACTOR, 3PH	3 Phase
	2E-Z8966		CONTACTOR, 50 AMP 208/240V 1PH	1 Phase
	2E-30901-08		FUSE HLD R FOR SC FUSE	
50	2E-Z5681	1	FUSEHOLDER, CLASS G	318HXGB-208V
NI	1L-Z12397	1	MULTIPURPOSE SYNTHETIC GREASE (80°F TO 400°F), TUBE 1 oz	
NI	2E-200554	2.5	TERMINAL BLOCK, 12 POS. LARGE	318HXGB-208V
NI	2E-200554	5	TERMINAL BLOCK, 12 POS. LARGE	
NI	2E-Z5680	2	FUSE, 5A - CLASS G	
NI	2H-Z13381	1	CURTAIN, PTFE	318HXGB-208V
NI	2P-115222	1	JUMPER, 3 POS. LARGE	
NI	2P-115521	3	JUMPER, 2 POS. LARGE	
NI	GD-115392	1	TERMINAL BLOCK, 3 POS, LARGE (Power Input)	
NI	GD-115396	1	TERMINAL BLOCK, 7 POS. LARGE	
NI	GD-115397	-	TERMINAL BLOCK, 8 POS, LARGE	
NI	GD-115523	2	JUMPER, 4 POS. LARGE	
NI	GD-115524	1	JUMPER, 5 POS. LARGE	
NI	GD-115528	1	JUMPER, 9 POS. LARGE	
NI	HM-115398	2	TERMINAL BLOCK, 9 POS. LARGE	



418HX Series Holman Conveyor Oven

Fig No.	Part Number	Quantity Per	Description	Fig No.	Part Number	Quantity Per	Description
1	GJ-401235	2	TRAY, CRUMB	34	2E-200180	6	SWITCH BARRIER, POT.
2	2A-200672	4	COLLAR, SHAFT	35	2J-200567	1	SWITCH, FRONT HEAT CONTROL POT. 3 PHASE
3	GJ-100710	1	RACK, BELT SUPPORT SYSTEM		2J-200567	1	SWITCH, TOP HEAT CONTROL POT.
4	GF-100405	1	TRAY, LOAD-UP	36	2J-200567	1	SWITCH, BOTTOM HEAT CONTROL POT. (Stratford Control)
5	2B-200619	1	LINK, CONVEYOR BELT	37	GB-118062	1	SWITCH, SPEED CONTROL (1000Ω)
	GF-160009	1	CONVEYOR BELT (14" X 75")	38	2J-200427	1	PILOT LIGHT
6	2B-200621	4	LINK, MASTER, CONVEYOR BELT	39	2R-200708	3	CAP, KNOB CONTROL
7	GJ-401161	1	COVER, TOP		2R-200708	4	CAP, KNOB CONTROL 3 PHASE
8	2A-200284	3	E-CLIP		2R-200768	3	KNOB, HEAT CONTROL, SPEED CONTROL
9	2C-200149	3	WASHER, BEARING		2R-200768	4	KNOB, HEAT CONTROL, SPEED CONTROL 3 PHASE
10	GB-112262	4	BUSHING 3/8"	40	2M-200873	1	LABEL, CONTROL PANEL (3 PHASE)
11	GF-101251	1	SHAFT ASSY IDLER		2M-200866	1	LABEL, CONTROL PANEL (3 PHASE)
12	2E-200574	1	SWITCH, FAN MOTOR	41	GJ-401381	1	PANEL, CONTROL SIDE
13	HG-402144	1	BRACKET, FAN SWITCH		GJ-401456	1	PANEL, CONTROL SIDE (3 PHASE)
14	GJ-401236	1	RETAINER, HEATER TUBE RIGHT	42	2U-200561	1	MOTOR, FAN
15	2J-200568	2	PROBE, HEAT (Stratford Control Model)	43	GF-402818	1	COVER, CONTROL BOX
	2J-200568	3	PROBE, HEAT (Stratford Control Model)	44	2R-200562	1	GRILL, FAN MOTOR
16	GD-401206	4	COVER, EXTENSION SIDE	45	2C-Z5883	4	SCREW, 10-24 X 1/2 FZA, SELF DRILLING
17	GJ-400786	1	PANEL, CORD SIDE (L-R MODEL)	46	2J-200569	2	CONTROL, HEAT (Stratford Control)
	GD-401377	1	PANEL, CORD SIDE (R-L MODEL)		2J-200569	3	CONTROL, HEAT (Stratford Control) 3 PHASE
18	2K-200458	1	BUSHING, POWER SUPPLY CORD	47	2E-200566	1	SWITCH, HIGH LIMIT RESET
20	GF-101250	1	SHAFT ASSY DRIVE	48	SP-115339	2	CONTROL, HEAT (Phase Control)
21	GF-401289	2	SHUTTER, HEAT	49	2E-200529	1	CONTACTOR 3PH
22	GF-101404	1	TRAY, UNLOAD		2E-Z8966	1	CONTACTOR 50 AMP 208/240V 1PH
23	2P-150023	1	DRIVE CHAIN (27")	NI	GD-115392	1	TERMINAL BLOCK, 3 POS, LARGE (Power Input)
24	2P-200654	1	SPROCKET, DRIVEN (25B24 X 3/8")	NI	GD-115396	1	TERMINAL BLOCK, 7 POS. LARGE
25	2P-200643	1	SPROCKET, DRIVE (25B11 X 5/16")	NI	HM-115399	2	TERMINAL BLOCK, 10 POS. LARGE
26	2U-Z11871	1	MOTOR, DRIVE (L-R), CCW	NI	2E-200554	5	TERMINAL BLOCK, 12 POS. LARGE
27	2U-200508	1	MOTOR, DRIVE 3286 BB REV, 50 hrz	NI	2P-115521	9	JUMPER, 2 POS. LARGE
28	2R-200721	1	BLADE, FAN, DRIVE MOTOR	NI	2P-115522	3	JUMPER, 3 POS. LARGE
28	2R-200716	4	LEG, 2 1/2" METAL	NI	GD-115523	1	JUMPER, 4 POS. LARGE
29	GJ-197881	12	HEATERTUBE QUARTZ	NI	GJ-115525	1	JUMPER, 6 POS. LARGE
	GJ-197894	12	HEATERTUBE QUARTZ	NI	1P-Z12397	1	EXTREME PRESSURE MULTIPURPOSE SYNTHETIC GREASE (80°F TO 400°F), TUBE 1 oz.
	GJ-197882	12	HEATERTUBE QUARTZ				
31	GD-401232	6	RETAINER, DUAL HEATER TUBES				
32	2E-200564	1	SWITCH, ON/OFF TOGGLE				
33	2P-401780	1	TOGGLE GUARD				

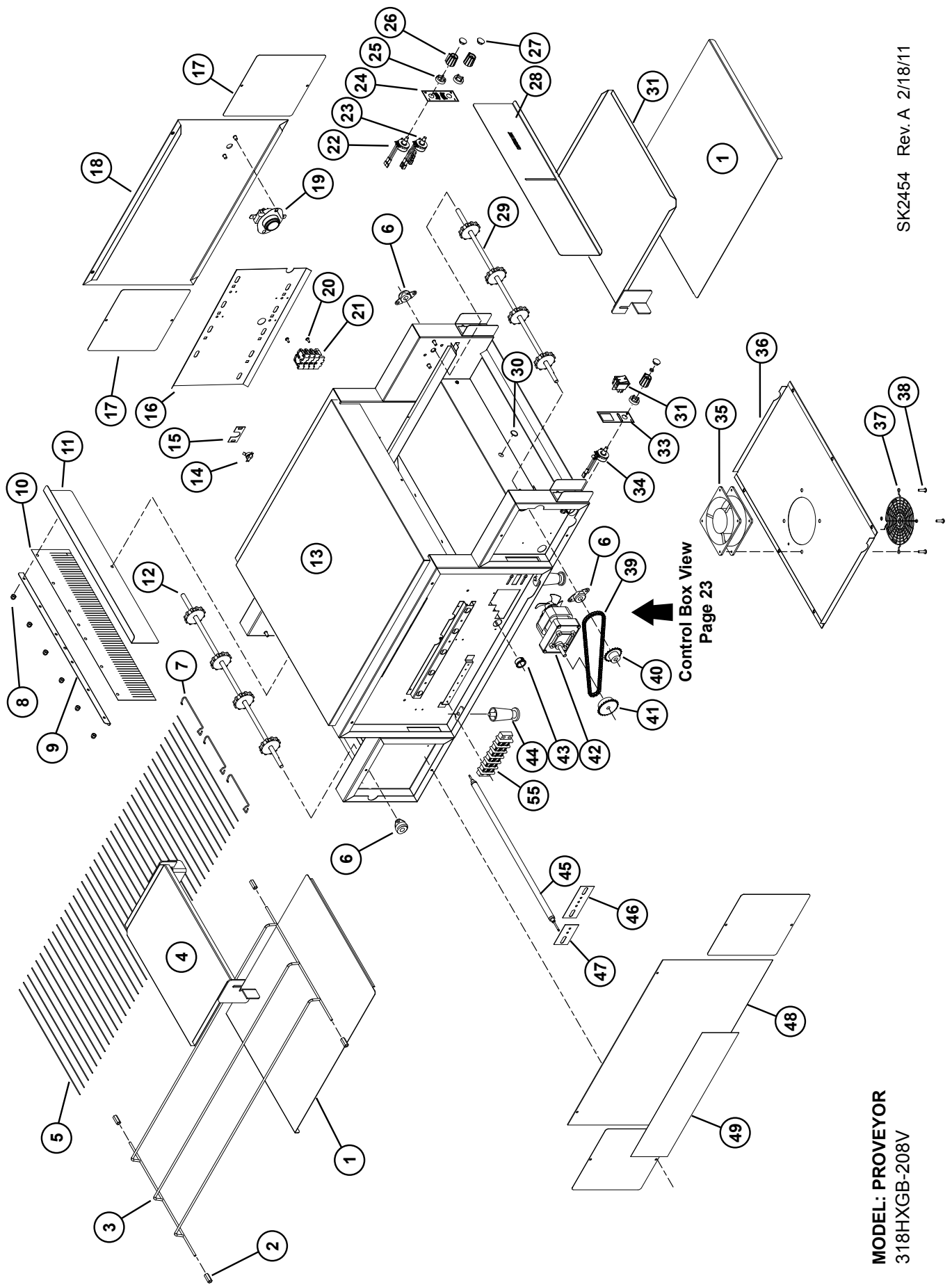

MODEL: PROVEYOR
318HXGB-208V

SK2454 Rev. A 2/18/11



318HXGB Pita Toaster Holman Conveyor Oven

Fig No.	Part Number	Quantity Per	Description	Fig No.	Part Number	Quantity Per	Description
1	GF-401228	2	TRAY, CRUMB	29	GD-Z10341	1	DRIVE SHAFT ASSEMBLY 318
2	2A-200672	3	COLLAR SHAFT 3/8 #1F51	31	GF-101404	1	TRAY, UNLOAD
3	GF-100709	1	RACK, 318HX	32	2E-Z1858	1	SWITCH-LIGHTED
4	GF-100405	1	TRAY, LOAD UP	33	2M-Z13367	1	LABEL, ON/OFF/SPEED
5	GF-160009	1	CONVEYOR BELT (14" X 75")	34	GD-Z13420	1	SPEED CONTROL 1KOHM
6	GB-112262	4	BEARING ASSY, 3/8 TEFLON	35	2U-200577	1	MOTOR,FAN 240V HI-OUT
7	2B-200621	4	BELT LINK, HX SPACE CLIP	36	GF-402818	1	CONTROL BOX COVER
8	2C-200061	6	NUT, 10-24 ACORN	37	2R-200562	1	FAN GUARD
9	GF-Z13370	1	CURTAIN CLAMP	38	2C-Z5883	4	SCREW, 10-24 X 1/2 FZA, SELF DRILLING
10	2H-Z13380	1	CURTAIN, PTFE	39	2P-150023	1	CHAIN NO. 25 108 LINKS
11	GF-Z13378	1	CURTAIN SHUTTER	40	2P-200650	1	SPROCKET, 25B24 X 5/16
12	GD-Z10342	1	IDLER SHAFT ASSEMBLY 318	41	2P-200653	1	SPROCKET, 25B20 X 3/8
13	GF-401167	1	COVER, TOP	42	2U-Z11871	1	MOTOR, DRIVE 72 BB REV
14	2E-200574	1	SWITCH,FAN, CERAMIC,	43	2K-200464	5	BUSHING, WIRE RING 7/8"
15	HG-402144	1	FAN SWITCH BRACKET (-T)	44	2R-200716	4	LEG, 2.5 IN METAL
16	GD-401238	1	RETAINER RIGHT TUBE	45	GF-Z13162	9	HEATERTUBE, QUARTZ
17	GD-401206	4	COVER, EXTENSION	46	GD-401232	4	RETAINER, LEFT TUBE
18	GD-Z13368	1	PANEL, SIDE - PLAIN	47	GD-402446	1	RETAINER, SINGLE TUBE
20	2C-200004	18	SCREW 6-32X5/16 THP SS	48	GD-Z13368	1	PANEL, SIDE - PLAIN
21	SP-115402	1	ASSY, 3 POS, TERMINAL BLK	49	2M-Z13365	2	LABEL, GARBANZOS
22	GD-115350	1	CONT, HEAT ASSY 200K TOP	50	2J-200541	3	CONTROL, PHASE, 240V,230P
23	GD-115635	1	HEAT CONTROL - PARALLEL	51	2E-Z5681	1	FUSEHOLDER, CLASS G
24	2M-Z13366	1	LABEL, TOP/BOTTOM HEAT	52	2E-Z5680	2	FUSE, 5A - CLASS G
25	2R-200713	3	SKIRT, CTRL KNOB W/STRIPE	53	2R-200721	1	BLADE, FAN 2 5/16
26	2R-200768	3	KNOB, CONTROL Q SERIES	54	2E-Z8966	1	CONTACTOR 50 AMP 208/240V
27	2R-200708	3	KNOB, CONTROL CAP	55	2E-Z14254	3	TERMINAL BLOCK 6-POLE
28	GF-401289	1	SHUTTER, HEAT				
				NI	2E-Z13500	1	CORD #8-3 6-50 90 GRIP
				NI	GD-Z11260	1	CORDSET 10-3 W/ 6-50 PLUG
				NI	2C-200467	3	CLAMP, NYLON WIRE 5/8
				NI	2E-200387	1	CORD FAN PLUG
				NI	2E-200472	3	TERMINAL BLOCK LG 222
				NI	2E-200473	1	TERMINAL BLOCK END LG 230

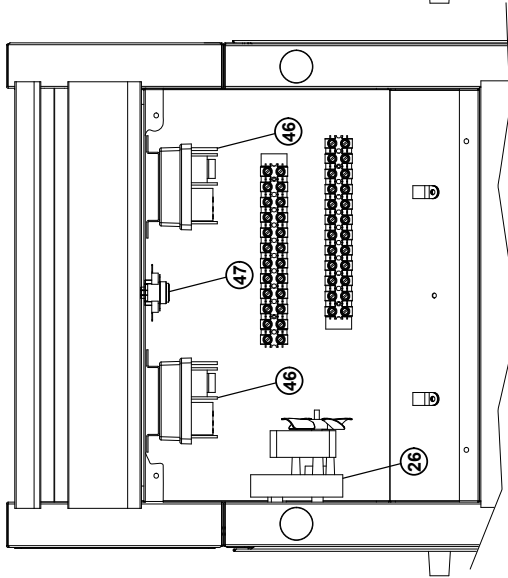

314 Stratford Control
Left to Right Conveyor

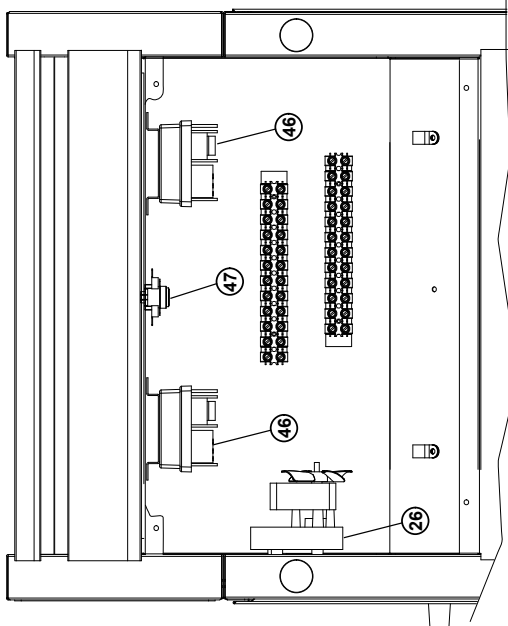

318 Stratford Control
Left to Right Conveyor

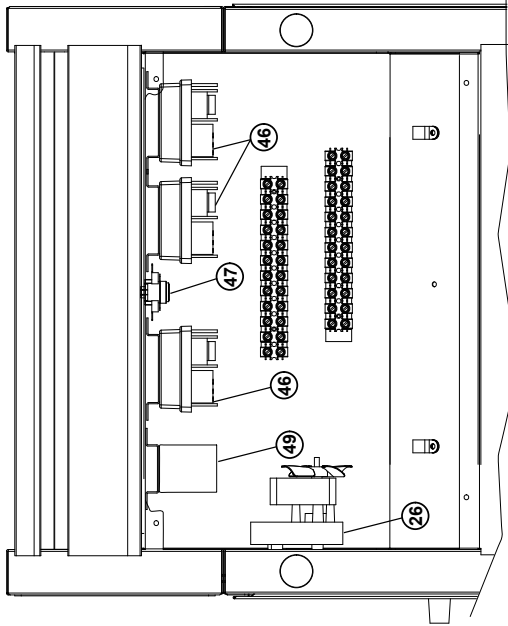

318 Stratford Control 3 Phase
Left to Right Conveyor

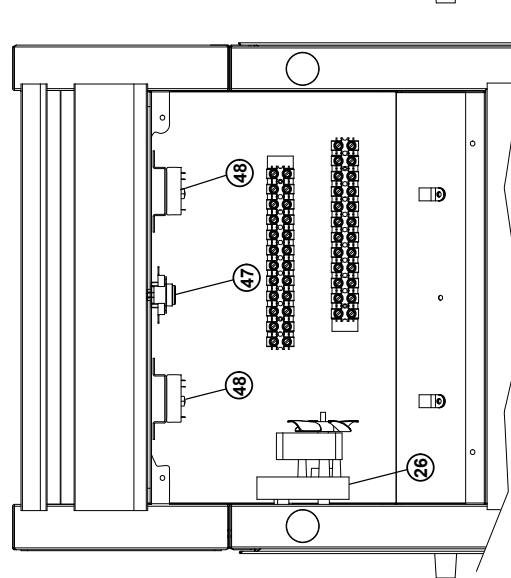

314 Phase Control
Left to Right Conveyor

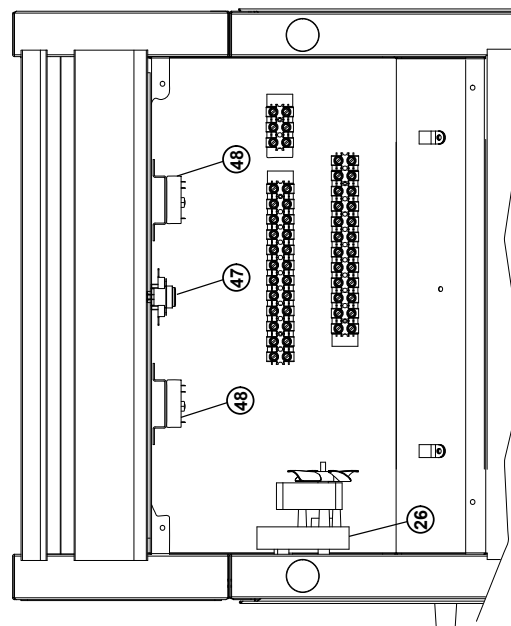

318 Phase Control
Left to Right Conveyor

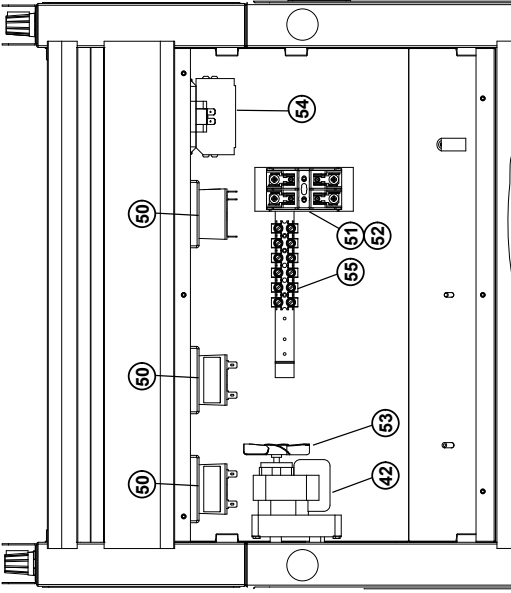

318HXGB
Pita Toaster

MODEL: PROVEYOR CONTROL BOX CONFIGURATION

SK2146 Rev.A 4/16/2010

STAR INTERNATIONAL HOLDINGS INC. COMPANY

Star - Holman - Lang - Wells - Toastmaster
265 Hobson Street, Smithville, TN 37166 U.S.A
(800) 264-7827
www.star-mfg.com