

Control Box View
Page 23

MODEL: PROVEYOR
314HX, 318HX, 418HX





314HX Series Holman Conveyor Oven

Fig No	Part No	Qty	Description	App.
1	GD-401227	2	TRAY, CRUMB	
2	2A-200672	4	COLLAR, SHAFT	
3	GD-100707	1	RACK, BELT SUPPORT SYSTEM	
4	GD-100403	1	TRAY, LOAD-UP	
5	GD-160008	1	CONVEYOR BELT (14" X 75")	
6	2B-200626	3	LINK, MASTER, CONVEYOR BELT	
7	GD-401168	1	COVER, TOP	
8	2A-200284	3	E-CLIP	
9	2C-200149	3	WASHER	
10	GB-112262	4	BUSHING 3/8"	
11	GD-101253	1	SHAFT, IDLER (3/8")	
12	2E-200574	1	SWITCH, FAN MOTOR	
13	HG-402144	1	FAN SWITCH BRACKET	
14	GD-401238	1	RETAINER, HEATER TUBE RIGHT	
15	2J-200568	2	PROBE, HEAT (Stratford Control Model)	3 Phase
		3		
16	GD-401206	4	COVER, EXTENSION SIDE	
17	GD-101488	1	PANEL ASSY, PLUG SIDE (L-R MODEL)	
	GD-101489		PANEL ASSY, PLUG SIDE (R-L MODEL)	
18	2K-200458	1	BUSHING, POWER SUPPLY CORD	
19	GD-Z11260	1	CORDSET 10-3 W/6-50P, 50A, Ser No on/after CO3181009A0001	314HX
	2E-200383	1	CORD/PLUG SEET, 10GA, 30A, Ser No Before CO3181009A0001	
20	GD-101252	1	SHAFT, DRIVE (3/8")	
21	GD-401233	2	SHUTTER, HEAT	
22	GD-101403	1	TRAY, UNLOAD	
23	2P-150023	1	DRIVE CHAIN (27")	
24	2P-200654	1	SPROCKET, DRIVEN (25B24 X 3/8")	
	2P-115362		SPROCKET, DRIVEN (25B11 X 3/8")	314HXRD, HXRRD
25	2P-200643	1	SPROCKET, DRIVE (25B11 X 5/16")	
	2P-200650		SPROCKET, DRIVE (25B24 X 5/16")	314HXRD, HXRRD
26	2U-Z11871	1	MOTOR, DRIVE (L-R), CCW	208/240V
	2U-Z11870		MOTOR, DRIVE (R-L), CW	208/240V
27	2R-200721	1	BLADE, FAN, DRIVE MOTOR	

Fig No	Part No	Qty	Description	App.
28	2R-200716	4	LEG, 2 1/2" METAL	
29	GD-197888	9	HTERTUBE, QRTZ; 208V, 613W, 67.9 ohm	208V
	GD-197893		HTERTUBE, QRTZ; 220V, 600W, 78.7 ohm	220V
	GD-197889		HTERTUBE, QRTZ; 240V, 600W, 90 ohm	240V
	2N-209201		ELEMENT, METAL, 600W, 208V 1	208V
	2N-209203		ELEMENT, METAL, 600W, 240V, 1	314HXTA, 314HXTAR
30	GD-402446	1	RETAINER, SINGLE HTERTUBE, QUARTZ	
	GD-401238		RETAINER, SINGLE HTERTUBE, METAL	
31	GD-401232	4	RETAINER, DUAL HTERTUBES, QUARTZ	
	GG-401989		RETAINER, HEATERTUBES, METAL	
32	2E-200564	1	SWITCH, ON/OFF TOGGLE	314HX
33	2P-401780	1	GUARD, TOGGLE	
34	2E-200180	3	INSULATION, SWITCH, POT.	
35	2J-200567	1	SWT, FRONT HEAT CNTRL POT., 3Ph Stratford	3 Phase, Stratford
	2J-200567		SWT, TOP HEAT CNTRL POT. Stratford	
	GD-115350		SWITCH, CNTRL HEAT ASSY TOP, Phase Cntrl	
36	2J-200567	1	SWITCH, BTM HEAT CNTRL POT. Strat	
	GD-115351		SWITCH, CNTRL HEAT ASSY BTM, Phase	
37	GB-118062	1	SWITCH, SPEED CNTRL ASSY (1000Ω)	314HX
38	2J-200427	1	PILOT LIGHT	
39	2R-200708	3	CAP, KNOB CONTROL	3 Phase
		4		
	2R-200768	3	KNOB, HEAT CONTROL, SPEED CONTROL	3 Phase
		4		
40	2M-200866	1	LABEL 3 PHASE HX CONTROL LABEL	3 Phase
	2M-200872		LABEL, CONTROL PANEL	
41	GD-401375	1	PANEL, CONTROL SIDE	3 Phase
	GD-401540			
42	2U-200561	1	MOTOR, FAN	
43	HT-401496	1	COVER, CONTROL BOX	
44	2R-200562	1	GRILL, FAN MOTOR	
45	2C-Z5883	4	SCREW, 10-24 X 1/2 FZA, SELF DRILLING	



314HX Series Holman Conveyor Oven

Fig No	Part No	Qty	Description	App.
46	2J-200569	2	CONTROL, HEAT (Stratford Control)	
		3	CONTROL, HEAT (3 PHASE)	3 Phase
47	SP-115146	1	SWITCH, HIGH LIMIT RESET	
48	SP-115338	2	CONTROL, HEAT (Phase Control)	120V
	SP-115339			3 Phase
49	2E-200529	1	CONTACTOR 3PH	3 Phase
	2E-Z8966		CONTACTOR, 50AMP 208/240V 1PH	1 Phase
50	2E-30901-08	2	FUSE HLDR FOR SC FUSE	
NI	2E-Z5680	2	FUSE, 5A - CLASS G	
NI	2B-200624	ea.	LINK, CONVEYOR BELT	
NI	2E-200554	~	TERMINAL BLOCK, 12 POS. LARGE	
NI	2J-200423	2	SWITCH, SPEED CONTROL (1000Ω)	240V/50/ 3PH
NI	GD-115392	1	TERMINAL BLCK, 3 POS. LARGE (Power Input)	
NI	GD-115396	~	TERMINAL BLOCK, 7 POS. LARGE	
NI	GD-115397	~	TERMINAL BLOCK, 8 POS. LARGE	
NI	GD-115523	~	JUMPER, 4 POS. LARGE	
NI	GD-118060	1	SPEED CONTROL,	V82, V84
NI	HM-115398	~	TERMINAL BLOCK, 9 POS. LARGE	
NI	HM-115521	~	JUMPER, 2 POS. LARGE	
NI	HM-115522	~	JUMPER, 3 POS. LARGE	
NI	1L-Z12397	1	CHAIN LUBE 1oz TUBE	

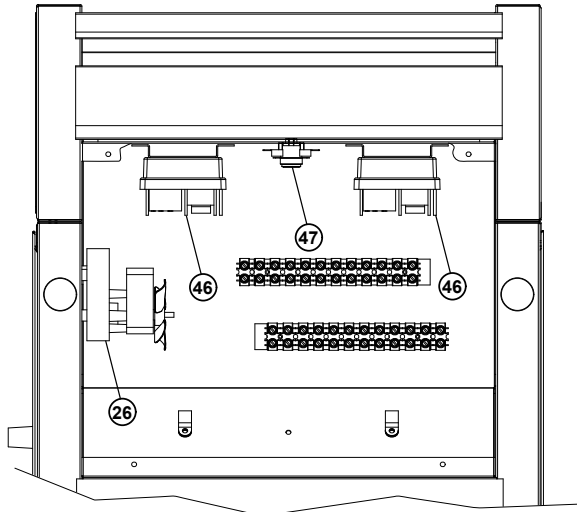

314 Stratford Control
Left to Right Conveyor

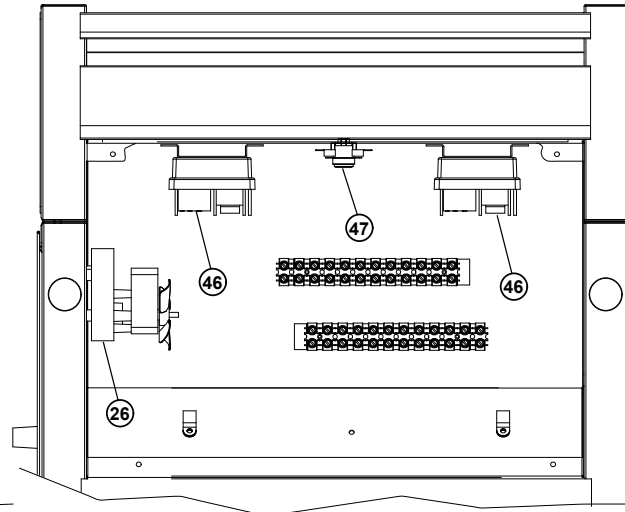

318 Stratford Control
Left to Right Conveyor

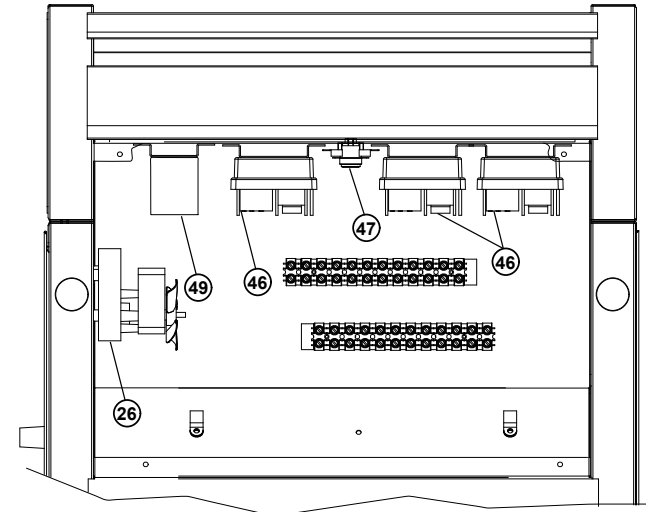

318 Stratford Control 3 Phase
Left to Right Conveyor

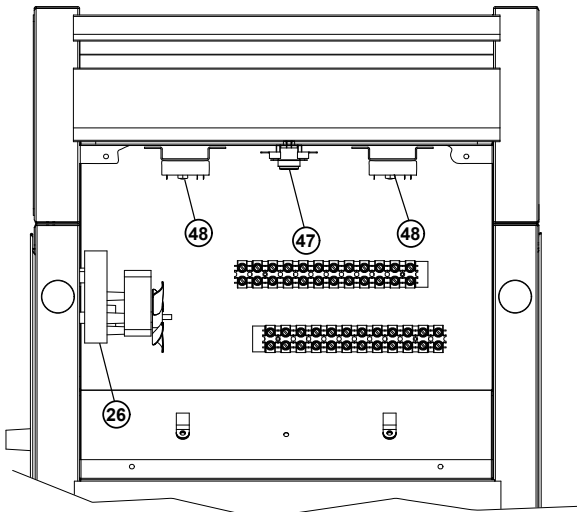

314 Phase Control
Left to Right Conveyor

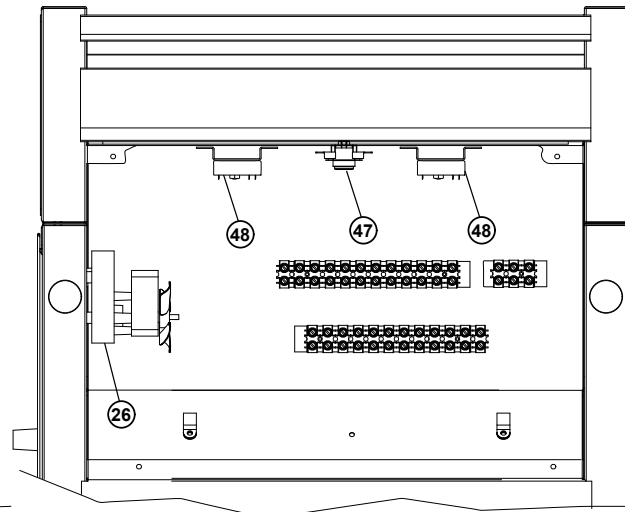

318 Phase Control
Left to Right Conveyor

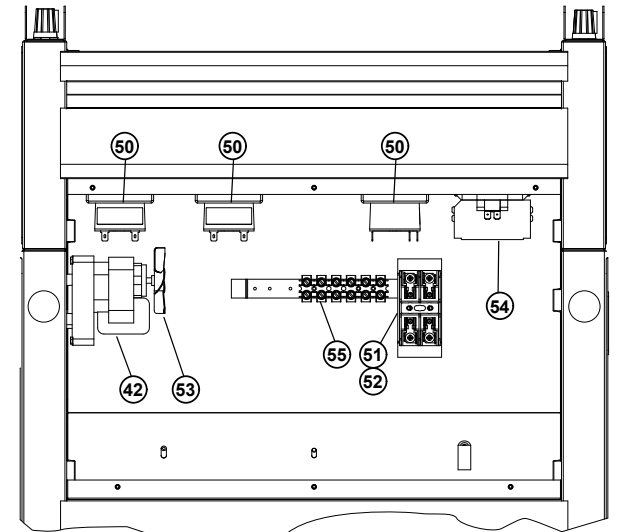

318HXGB
Pita Toaster