

MODEL: PROVEYOR
 314HX, 318HX, 418HX





318HX Series Holman Conveyor Oven

Fig No	Part No	Qty	Description	Application
1	GF-401228	2	TRAY, CRUMB	
2	2A-200672	4	COLLAR, SHAFT	
3	GF-100709	1	RACK, BELT SUPPORT SYSTEM	
4	GF-100405	1	TRAY, LOAD-UP	
5	GF-160009	1	CONVEYOR BELT (18" X 75")	
6	2B-200621	4	LINK, MASTER, CONVEYOR BELT	
7	GF-401167	1	COVER, TOP	
8	2A-200284	3	E-CLIP	
9	2C-200149	3	WASHER	
10	GB-112262	4	BUSHING 3/8"	
11	GF-101251	1	SHAFT ASSY, IDLER	
12	2E-200574	1	SWITCH, FAN MOTOR	
13	HG-402144	1	BRACKET, FAN SWITCH	
14	GD-401238	1	RETAINER, HEATER TUBE, RIGHT	
15	2J-200568	2	PROBE, HEAT (Stratford Control Model)	
	2J-200568	3	PROBE, HEAT (Stratford Control Model)	3 Phase
16	GD-401206	4	COVER, EXTENSION SIDE	
17	GD-101488	1	PANEL ASSY, PLUG SIDE CORD SIDE (L-R MODEL)	
	GD-101489		PANEL ASSY, PLUG SIDE CORD SIDE (R-L MODEL)	
18	2K-200458	1	BUSHING, POWER SUPPLY CORD	
19	2E-200383	1	**CORD, POWER SUPPLY Serial No Before CO3181107B0001	
	GD-Z11260		CRDSET 10-3 W/ 6-50 PLG Ser No on/after CO3181107B0001	
	GD-Z11260		CORDSET 10-3 W/6-50 PLUG	318HXGB-208V
20	GF-101250	1	SHAFT ASSY, DRIVE	
21	GF-401289	2	SHUTTER, HEAT	
22	GF-101404	1	TRAY, UNLOAD	
23	2P-150023	1	DRIVE CHAIN (27")	
24	2P-200654	1	SPROCKET, DRIVEN (25B24 X 3/8")	
25	2P-200643	1	SPROCKET, DRIVE (25B11 X 5/16")	
26	2U-Z11871	1	MOTOR, DRIVE (L-R), CCW	Left to Right
	2U-Z11870		MOTOR, DRIVE (R-L), CW	Right to Left
27	2R-200721	1	BLADE, FAN, DRIVE MOTOR	
28	2R-200716	4	LEG, 2 1/2" METAL	

Fig No	Part No	Qty	Description	Application
29	2N-209205	9	HEATERTUBE, METAL 688W	208V
	2N-209207		HEATERTUBE, METAL 688W	240V
	GF-197885		HEATERTUBE QUARTZ	208V
	GF-197886		HEATERTUBE QUARTZ	240V
	GF-197891		HEATERTUBE QUARTZ	220V
	GG-114250		HEATERTUBE, METAL 690W	208V
30	GD-401238	1	RETAINER, SINGLE HEATERTUBE, METAL	
	GD-402446		RETAINER, SINGLE HEATERTUBE, QUARTZ	
31	GD-401232	4	RETAINER, DUAL HEATERTUBES, QUARTZ	
	GG-401989		RETAINER, DUAL HEATERTUBES, METAL	
32	2E-200564	1	SWITCH, ON/OFF TOGGLE	
	2E-Z1858		SWITCH - LIGHTED	318HXGB-208V
33	2P-401780	1	GUARD, TOGGLE	
34	2E-200180	3	SWITCH BARRIER, POT	
35	2J-200567	1	SWITCH, FRNT HEAT CNTRL POT., STRAT	3 Phase
	2J-200567		SWITCH, TOP HEAT CNTRL POT., STRAT	
	GD-115350		CONT, HEAT ASSY 200K TOP, PHASE CNTRL	318HXGB-208V
36	2J-200567	1	SWITCH, BOTTOM HEAT CONTROL POT.	
	GD-115635		HEAT CONTROL - PARALLEL	318HXGB-208V
	GD-115351		CONT, HEAT ASSY 200K BTM, PHASE CNT	
37	GB-118062	1	SWITCH, SPEED CONTROL (1000Ω)	
	GD-Z13420		SPEED CONTROL 1kOHM	318HXGB-208V
38	2J-200427	1	PILOT LIGHT	
39	2R-200708	3	CAP, KNOB CONTROL	
	2R-200708	4	CAP, KNOB CONTROL	3 Phase
	2R-200768	3	KNOB, HEAT CONTROL, SPEED CONTROL	
	2R-200768	4	KNOB, HEAT CONTROL, SPEED CONTROL	3 Phase
40	2M-200866	1	LABEL, CONTROL PANEL	3 Phase
	2M-200872	1	LABEL, CONTROL PANEL	
41	GD-401375	1	PANEL, CONTROL SIDE	
42	2U-200561	1	MOTOR, FAN	
43	GF-402818	1	COVER, CONTROL BOX	
44	2R-200562	1	GRILL, FAN MOTOR	
45	2C-Z5883	4	SCREW, 10-24 X 1/2 FZA, SELF DRILLING	
46	SP-115347	2	CONTROL, HEAT (Stratford Control)	
	SP-115347	3	CONTROL, HEAT (Stratford Control)	3 Phase



318HX Series Holman Conveyor Oven

Fig No	Part No	Qty	Description	Application
47	2E-200566	1	SWITCH, HIGH LIMIT RESET	
48	SP-115339	2	CONTROL, HEAT (Phase Control)	
	SP-115339	3	CONTROL, HEAT (Phase Control)	3 Phase
49	2E-200529	1	CONTACTOR, 3PH	3 Phase
	2E-Z8966		CONTACTOR, 50 AMP 208/240V 1PH	1 Phase
50	2E-30901-08	2	FUSE HLDR FOR SC FUSE	
	2E-Z5681	1	FUSEHOLDER, CLASS G	318HXGB-208V
NI	1L-Z12397	1	MULTIPURPOSE SYNTHETIC GREASE (80°F TO 400°F), TUBE 1 oz	
NI	2E-200554	2.5	TERMINAL BLOCK, 12 POS. LARGE	318HXGB-208V
NI	2E-200554	5	TERMINAL BLOCK, 12 POS. LARGE	
NI	2E-Z5680	2	FUSE, 5A - CLASS G	
NI	2H-Z13381	1	CURTAIN, PTFE	318HXGB-208V
NI	2P-115222	1	JUMPER, 3 POS. LARGE	
NI	2P-115521	3	JUMPER, 2 POS. LARGE	
NI	GD-115392	1	TERMINAL BLOCK, 3 POS, LARGE (Power Input)	
NI	GD-115396	1	TERMINAL BLOCK, 7 POS. LARGE	
NI	GD-115397	-	TERMINAL BLOCK, 8 POS, LARGE	
NI	GD-115523	2	JUMPER, 4 POS. LARGE	
NI	GD-115524	1	JUMPER, 5 POS. LARGE	
NI	GD-115528	1	JUMPER, 9 POS. LARGE	
NI	HM-115398	2	TERMINAL BLOCK, 9 POS. LARGE	

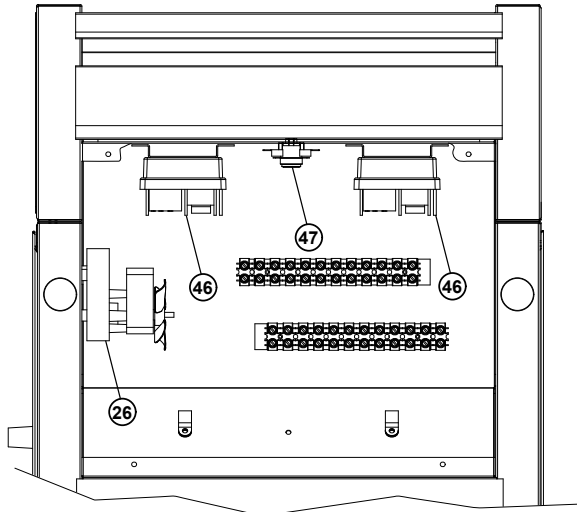

314 Stratford Control
Left to Right Conveyor

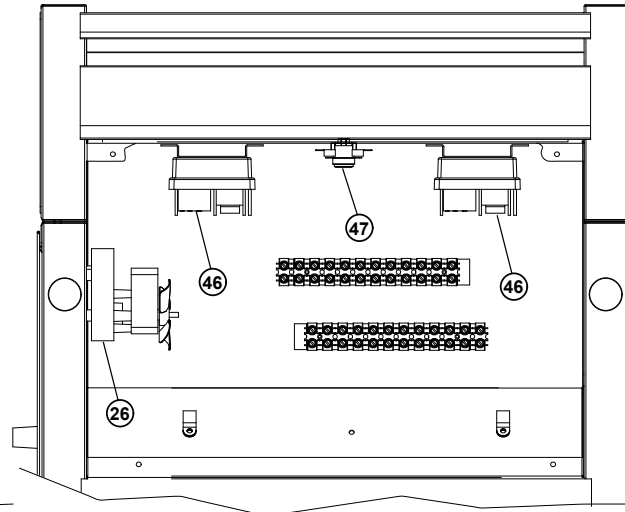

318 Stratford Control
Left to Right Conveyor

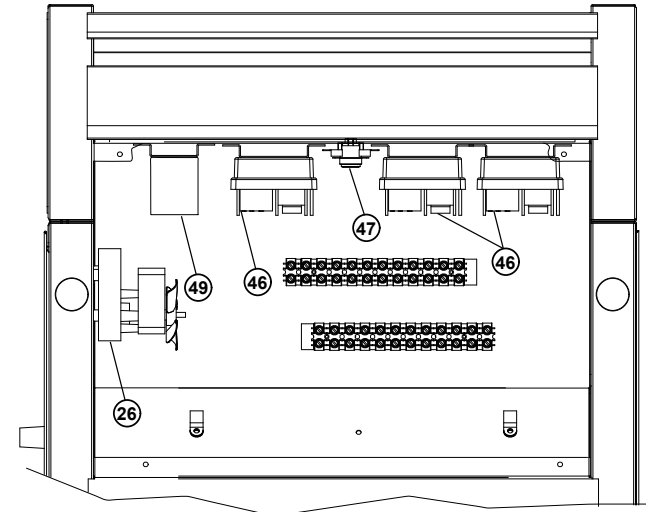

318 Stratford Control 3 Phase
Left to Right Conveyor

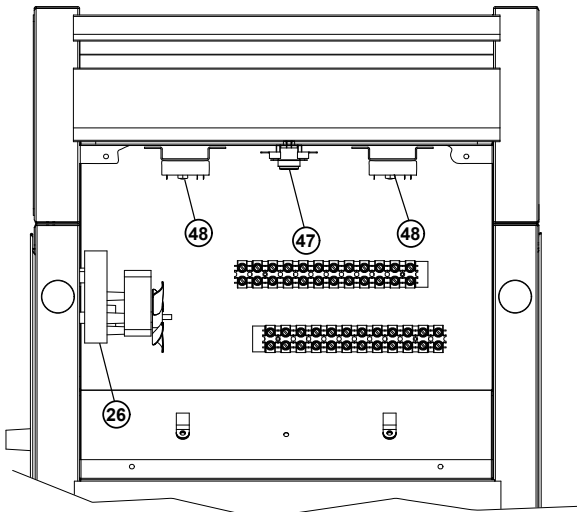

314 Phase Control
Left to Right Conveyor

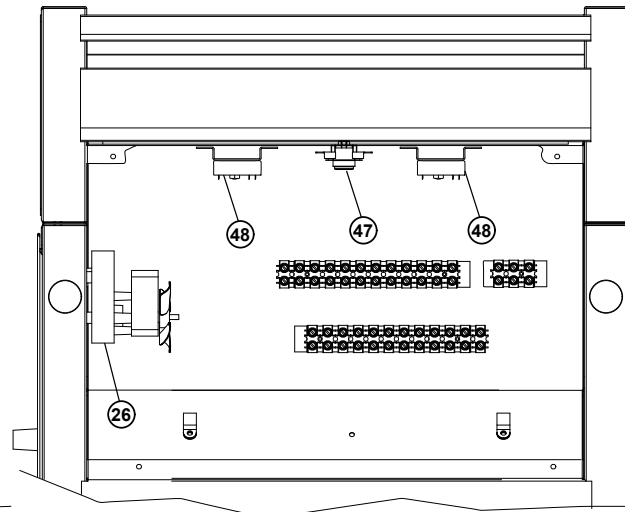

318 Phase Control
Left to Right Conveyor

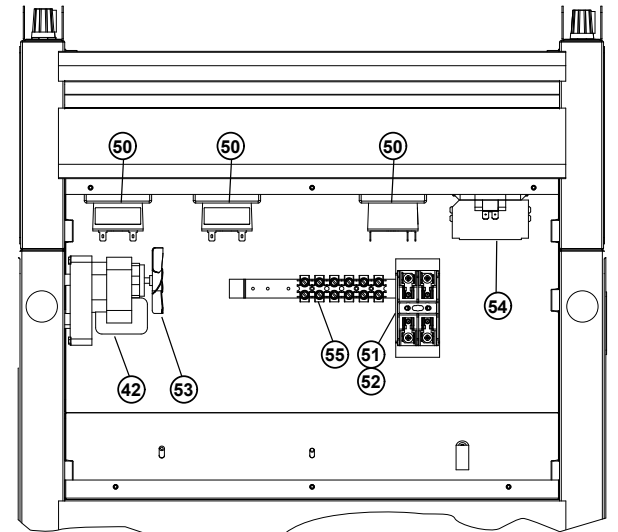

318HXGB
Pita Toaster