



ELECTRIC COUNTER TOP CONVECTION OVEN

CCOF-4
CCOH-3, CCOH-4
CCOQ-3

Installation and Operation Instructions

2M-Z10761 Rev. J 10-2018

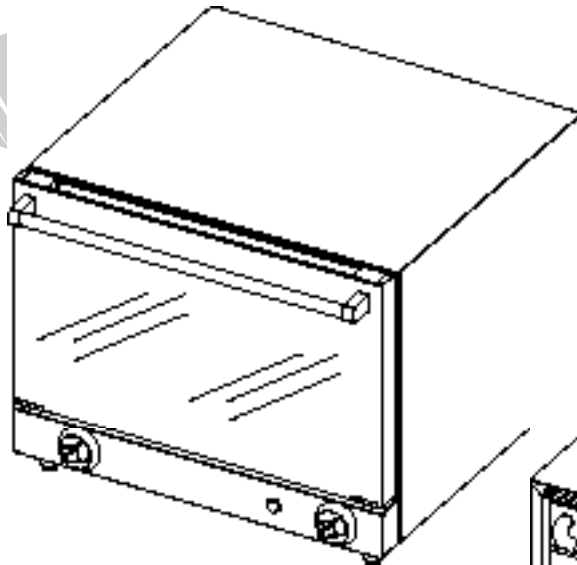

CCOQ-3

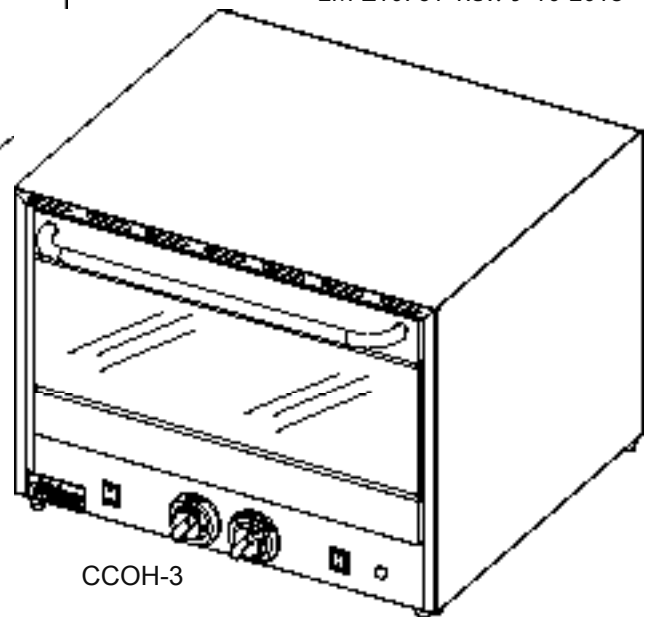

CCOH-3

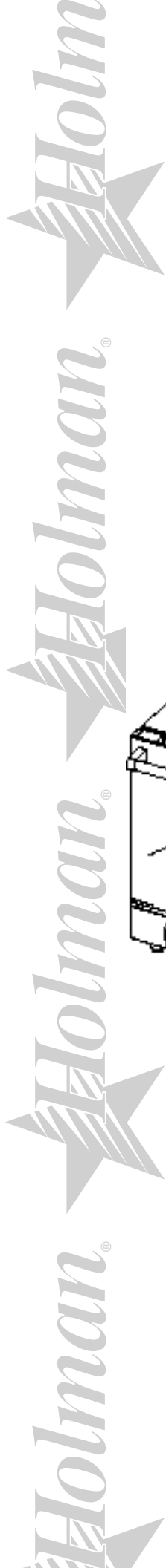

SAFETY SYMBOL



These symbols are intended to alert the user to the presence of important operating and maintenance instructions in the manual accompanying the appliance.

RETAIN THIS MANUAL FOR FUTURE REFERENCE NOTICE

Using any part other than genuine Star factory supplied parts relieves the manufacturer of all liability.

Star reserves the right to change specifications and product design without notice. Such revisions do not entitle the buyer to corresponding changes, improvements, additions or replacements for previously purchased equipment.

Due to periodic changes in designs, methods, procedures, policies and regulations, the specifications contained in this sheet are subject to change without notice. While Star International Holdings Inc., Company exercises good faith efforts to provide information that is accurate, we are not responsible for errors or omissions in information provided or conclusions reached as a result of using the specifications. By using the information provided, the user assumes all risks in connection with such use.

MAINTENANCE AND REPAIRS

Contact your local authorized service agent for service or required maintenance.

Please record the model number, serial number, voltage and purchase date in the area below and have it ready when you call to ensure a faster service.

Model No. _____
Serial No. _____
Voltage _____
Purchase Date _____

Authorized Service Agent Listing

Reference the listing provided with the unit

or

for an updated listing go to:

Website: www.star-mfg.com
E-mail customerservice@star-mfg.com

Service Help Desk

Business Hours: 8:00 am to 4:30 p.m. Central Standard Time

Telephone: (800) 264-7827

Fax: (314) 781-2714

E-mail customerservice@star-mfg.com

Website: www.star-mfg.com

Mailing Address: Star Manufacturing International Inc.
265 Hobson Street
Smithville, TN 37166
U.S.A

SPECIFICATIONS

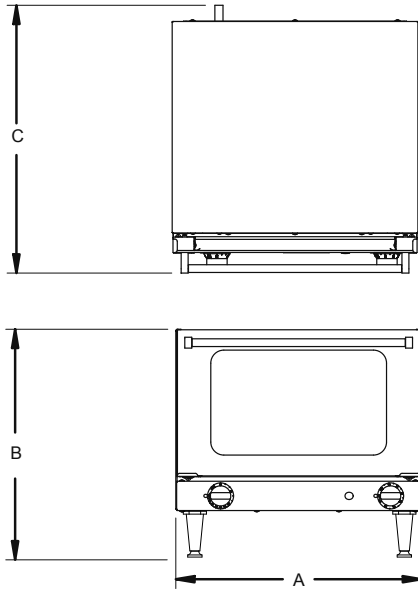

Holman Counter top Convection Ovens are constructed of highly polished stainless steel with high performance heating elements and rear fans, stainless steel door handle, chrome plated wire racks and rack slides. The bake chamber is made of stainless steel or porcelain. The oven door is double pane tempered glass and features a heavy-duty hinge mechanism. Thermostat range is 175°F to 500°F. Timer range is 0 to 120 minutes. Oven features a heat indicator light and door interlock switch. Oven holds either 3 or 4 standard size baking sheets. Units available in various voltages and is shipped with a NEMA plug installed.

Mode No.	"A" Width Inches/CM	"B" Height Inches/CM	"C" Depth Inches/CM	Approximate Ship Weight
CCOF-4	32.1in / 81.5cm	23.8in / 60.5in	30.9in / 78.5in	104lbs / 63.6kg
CCOH-3	24.4in / 62cm	21.5in / 54.6cm	23.4in / 59.4cm	86lbs / 39.1kg
CCOH-4	24.4in / 62cm	24.8in / 63cm	26.6in / 67.5cm	120lbs / 54.5kg
CCOQ-3	19in / 48.3cm	15in / 38.1cm	20.4in / 51.8cm	47lbs / 21.4kg

ELECTRICAL SPECIFICATIONS

Model No.	Voltage	Wattage	Amps	NEMA Plug
CCOF-4	208V	4,280	20.6	6-30
	220V	4,790	21.8	6-30
	230V	5,230	22.7	6-30
	240V	5,700	23.8	6-30
CCOH-3	120V	1,440	12	5-15
	220V	1,440	6.5	BS-1363A
CCOH-4	208V	2,130	10.2	6-15
	220V	2,380	10.8	6-15
	230V	2,600	11.3	6-15
	240V	2,830	11.8	6-15
CCOQ-3	120V	1,440	12	5-15
	220V	1,440	6.5	BS-1363A

OVEN FEATURE	CCOQ-3	CCOH-3	CCOH-3NB	CCOH-4	CCOF-4
<i>Number of Racks</i>	3	3	3	4	4
<i>Domestic Sheet Size</i>	1/4	1/2	1/2	1/2	FULL
<i>Stainless Steel Oven Chamber</i>	yes	yes	yes	yes	yes
<i>Number of Motors/Fan(s)</i>	1	1	1	2	2
<i>Reversible Motors</i>	no	no	no	no	yes
<i>Number of Interior Lights</i>	0	1	1	1	2
<i>Top Browning Element</i>	no	yes	no	no	no
<i>Steam Feature</i>	no	no	no	no	yes
<i>Manual Reset Hi-Limit Protection</i>	yes	yes	yes	yes	yes
<i>Door Interlock Switch</i>	yes	yes	yes	yes	yes
Timer					
<i>Single "Ding"</i>	yes	yes	yes	yes	yes



WARNING

THIS APPLIANCE MUST BE GROUNDED AT THE TERMINAL PROVIDED. FAILURE TO GROUND THE APPLIANCE COULD RESULT IN ELECTROCUTION AND DEATH.

INSTALLATION OF THE UNIT MUST BE DONE BY PERSONNEL QUALIFIED TO WORK WITH ELECTRICITY AND PLUMBING. IMPROPER INSTALLATION CAN CAUSE INJURY TO PERSONNEL AND/OR DAMAGE TO EQUIPMENT. UNIT MUST BE INSTALLED IN ACCORDANCE WITH ALL APPLICABLE CODES.

NOTICE

The data plate is located on the lower right side panel of the unit. The oven voltage, wattage, serial number, and clearance specifications are on the data plate. This information should be carefully read and understood before proceeding with the installation.

NOTICE

The installation of this unit must conform to applicable national, state and locally recognized installation standards.

NOTICE

The installation of any components such as a vent hood, grease extractors, fire extinguisher systems, must conform to their applicable National, State and locally recognized installation standards.



CAUTION

MOST CLEANERS ARE HARMFUL TO THE SKIN, EYES, MUCOUS MEMBRANES AND CLOTHING. PRECAUTIONS SHOULD BE TAKEN TO WEAR RUBBER GLOVES, GOGGLES OR FACE SHIELD AND PROTECTIVE CLOTHING. CAREFULLY READ THE WARNING AND FOLLOW THE DIRECTIONS OF THE LABEL OF THE CLEANER TO BE USED.



WARNING

KEEP WATER AND SOLUTIONS OUT OF CONTROLS. NEVER SPRAY OR HOSE CONTROL CONSOLE, ELECTRICAL CONNECTIONS, ETC.

BOTH HIGH AND LOW VOLTAGES ARE PRESENT INSIDE THE APPLIANCE WHEN THE UNIT IS PLUGGED/WIRED INTO A LIVE RECEPTACLE. BEFORE REPLACING ANY PARTS, DISCONNECT THE UNIT FROM THE ELECTRIC POWER SUPPLY.

NOTICE

Never use chlorine sanitizer in contact with stainless steel surfaces longer than 10 minutes. Longer contact can cause corrosion.

NOTICE

Service this, or any other Holman appliance must be performed by qualified personnel only. Consult your authorized service station directory or call the factory (at 1-800-807-9054), or log onto www.star-mfg.com for the service agent nearest you.



GENERAL INFORMATION

This equipment is designed and sold for commercial use only by personnel trained and experienced in its operation and is not sold for consumer use in and around the home nor for use directly by the general public in food service locations.

Before using your new equipment, read and understand all the instructions & labels associated with the unit prior to putting it into operation. Make sure all people associated with its use understand the units operation & safety before they use the unit.

All shipping containers should be checked for freight damage both visible and concealed.

This unit has been tested and carefully packaged to insure delivery of your unit in perfect condition. If equipment is received in damaged condition, either apparent or concealed, a claim must be made with the delivering carrier.

Concealed damage or loss - if damage or loss is not apparent until after equipment is unpacked, a request for inspection of concealed damage must be made with carrier within 15 days. Be certain to retain all contents plus external and internal packaging materials for inspection. The carrier will make an inspection and will supply necessary claim forms.

PURCHASER'S RESPONSIBILITY

It is the responsibility of the purchaser:

1. To see that the electric services for the oven are installed on site in accordance with the manufacturer's specifications and in compliance with all local codes.
2. To unload, un-crate, and install the oven in its proper location and in accordance with this installation operation manual.
3. To see that electric services are connected properly by a qualified installer of your choice.

CCOF-4 Models only

4. To see that there is a water purification system supplying the oven that meets Star Manufacturing Specifications. All connections must be in accordance with applicable code requirements.

UN-CRATING

The oven will arrive completely assembled and ready to use. Prior to un-crating move the oven as close to its final location as practical. This will protect it from damage associated with moving (scratches, dings, dropping).

These ovens weigh between 47 & 140 lbs. For safe handling, installer should obtain help as needed, or employ appropriate materials handling equipment (such as a forklift, dolly, or pallet jack) to remove the unit from the container and move it to the place of installation.



CAUTION

ANY STAND COUNTER OR OTHER DEVICE ON WHICH THE OVEN WILL BE LOCATED MUST BE DESIGNED TO SUPPORT THE WEIGHT OF THE OVEN.



NEVER lay oven with the control side down, this will damage the controls.

INSTALLATION

LOCATION

Do not install the Holman Counter top Convection Oven directly on the Floor. Holman/Star Manufacturing has stands available to accommodate your new oven.



DO NOT install oven closer than 1" on the control side, from another oven.
DO NOT install oven closer than 12" on the control side, from a uncontrolled heat source (char broiler, open flame, griddle, etc.), unless a Hi-Temperature Spacer is installed then it can be reduced to 1".

ELECTRICAL

The ovens are equipped for the voltage indicated on the nameplate mounted on the lower right side panel of the oven. They will operate on alternating current (AC) only. A cord & plug is provided installed.

All electrical connections must be made by a licensed electrician and in accordance with local codes or in the absence of local codes with NFPA No. 70 latest edition (in Canada use: CSA STD. C22.1)



DO NOT CONNECT TO DIRECT CURRENT (DC).

DO NOT CONNECT TO ANY OTHER TYPE OF CURRENT THAT IS OTHERWISE SPECIFIED FOR THIS SPECIFIC UNIT, OR MACHINE WILL BE SERIOUSLY DAMAGED.

AIR SUPPLY

Make certain not to obstruct the flow of combustion (gas) and ventilation air. Provisions for adequate air supply must be furnished.

LEVELING THE UNIT

This Holman Oven comes with legs installed at the factory, proper leveling is essential to receive a proper baking performance. Level unit by adjusting the (4) feet which have an adjustment of 1-3/4" (43.75mm) for accurate leveling.

WATER CONNECTION CCOF-4 UNIT ONLY

It is vital that the water supply line be thoroughly flushed with clean water before being connected to the oven's water manifold.

Note the reading on the water pressure regulator gauge (*not provided*), should read 20-25 PSI. If it reads more or less, adjust regulator until it falls into the proper range.

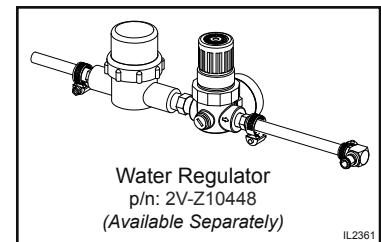

Connect water supply to 3/8" female quick disconnect fitting located at right rear corner of the oven. (3/8" female quick disconnect fitting accepts a 1/4" male quick disconnect coupler) Once the water manifold and water supply are connected to the oven turn the oven ON and press the 1-shot steam button for 30 seconds to remove the air and any impurities from the system.

WATER QUALITY REQUIREMENTS

Model CCOF-4 has a steam injection system, to ensure your new equipment works at it premium performance, we recommend that in areas where hard water is present, a water softener is used.

Contact your local water equipment system provider to assist you in determining your specific water quality, or contact Star Technical support for assistance, 1-800-807-9054.

OPERATION

INITIAL USE

Before using your Holman Counter Top Convection Oven for the first time, clean the unit using mild detergent and warm water, then heat for approximately 30 minutes. The unit may emit a small amount of smoke as the cooking surfaces reach 300-350°F (149-177°C). Do not be alarmed, as the smoke is caused by oils associated with the manufacturing process and will stop when the oven reaches 400°F (204°C).

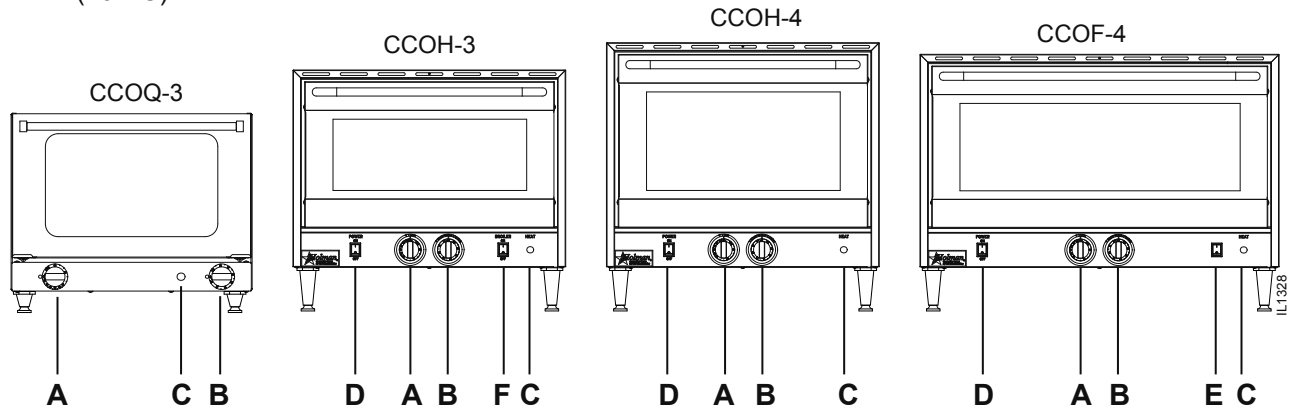

OVEN COMPONENTS DESCRIPTION

A: Timer: Timer **MUST** be **ON** for unit to work!

Timer Mode: This can be set at any range between 0 thru 120 minutes, when the timer reaches 0 the unit will turn the fan and heaters off.

Manual Mode: By turning it counter clockwise puts it into manual mode which will allow the fan and heater to run continuously until it is removed from this setting.

B: Temperature: This sets the cooking temperature between 175°F to 500°F (79°C to 260°C).

C: Indicator Light: This light will illuminate when the oven is being brought up to the desired temperature, it will turn off when the desired set temperature is reached.

D: On/Off Switch: Makes it easy to see at a glance when the oven is operating.

E: 1-Shot Steam: Provides a single shot of steam into the cooking chamber. The oven must be at operating temperature to receive this benefit, and should only be used in shots of 5 seconds periods.

F: Top Broiler Element: Provides intense heat for broiling, browning and finishing menu items.

G: Hi-Limit Reset: Mounted on the rear of the unit, it monitors the inside cooking temperature and will only trip when the unit reaches a high temperature (*approx. 600°F*) due to the unit being in an enclosed environment with no air cooling circulation.

TYPICAL OPERATION SEQUENCE

ACTION	RESULT
Press the ON/OFF switch.	Button lights up.
Adjust Temperature to desired setting and move timer to manual position.	Fan, heat and indicator light comes on. Fan will reverse only on CCOF-4 model.
Indicator lights shuts off.	Oven has reached desired temperature.
Load product into oven.	<i>See Hints & Suggestions - "Loading the Oven"</i> Fan will shut off when door is opened, this minimizes the heat loss.
Set Timer to desired cook time.	Timer starts timing down, the fan and heat turns on.
1-Shot Steam (CCOF-4 model only)	<i>See Convection Oven Baking Guide, Convection Ovens In General</i>
Cooking timer times out.	When 0 is reached the fan and heat shuts off, and the ON/OFF switch remains lit.
Unload Oven	<i>See Hints & Suggestions - "Unloading the Oven"</i>

MAINTENANCE

Contact the factory, a service representative or a local service company for service or required maintenance. Replacement cord sets must be purchased from Star Manufacturing International, Inc.

- Oven interiors should be wiped down daily and thoroughly cleaned weekly using warm water and mild detergent. **DO NOT use caustic cleaners.**

CLEANING

- Always start with a cold oven.
- The stainless exterior can easily be cleaned using stainless steel cleaner.
- Always follow the cleaner manufacturer's instructions when using any cleaner.
- Care should be taken to prevent caustic cleaning compounds from coming in contact with the fan wheel.
- The oven racks, rack slides, may be cleaned outside the oven cavity using oven cleaner.
- Using any harsh chemicals will result in the removal of the ETC coating and etching of the porcelain below it. The oven interior should only be cleaned using a mild soap and a non metal scouring pad. **DO NOT use caustic cleaners.**
- Always apply stainless steel cleaners when the oven is cold and rub in the direction of the metal's grain.



CAUTION

KEEP WATER AND SOLUTIONS OUT OF CONTROLS. NEVER SPRAY OR HOSE CONTROL CONSOLE.

MOST CLEANERS ARE HARMFUL TO THE SKIN, EYES, MUCOUS MEMBRANES AND CLOTHING. PRECAUTIONS SHOULD BE TAKEN TO WEAR RUBBER GLOVES, GOGGLES OR FACE SHIELD AND PROTECTIVE CLOTHING.

CAREFULLY READ THE WARNING AND FOLLOW THE DIRECTIONS ON THE LABEL OF THE CLEANER TO BE USED.

NEVER LEAVE A CHLORINE SANITIZER IN CONTACT WITH STAINLESS STEEL SURFACES LONGER THAN 10 MINUTES. LONGER CONTACT CAN CAUSE CORROSION.

CLEANING THE FAN

The fan located behind the rear panel should be cleaned periodically. Depending on the amount and type of use the unit receives, dirt & grime will build up on the fan, causing it to possibly shorten the life of the motor.

To clean simply:

1. Unplug unit and allow to cool.
2. Loosen screws shown here and remove rear panel.
3. Using damp cloth, wipe fan until clean.
4. Reassembly and test for proper operation.

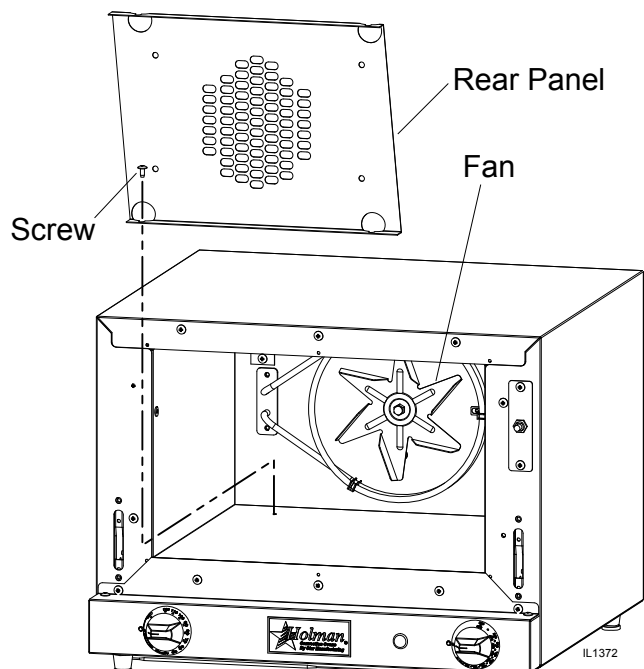

2M-Z10761: Holman Electric Counter Top Convection Oven

CONVECTION OVEN BAKING GUIDE

CONVECTION OVENS IN GENERAL

- Convection ovens constantly circulate air over the product. This strips away the thin layer of moisture laden air from the top of the product allowing heat to penetrate more quickly. This allows cooking times to be shortened and cooking temperatures reduced in convection ovens. Introducing steam into the cooking process prevents the bake from losing moisture and allows for a better product.
- Applying steam to dough during first 5 minutes, allows the yeast to work a little longer, allowing for better oven spring and loaf volume keeping the outer layer flexible and moist. Once the outside layer of the dough sets, gases in the loaf can no longer expand to increase the loaf size.
- Steaming the dough as it bakes also gelatinizes starch on the outside layer, producing a bread with a crisp crust and a brown crust color in varying degrees; too much steam results in an undesirable crust. Steam also helps to prevent wild breaks in the loaves because it delays the setting of the bread's crust, allowing it more time to bake and brown. However, in contrast, during the last stages of baking, a dry oven is required when the crust is browning; after the steam is removed, the gelatinized layer dries out forming a thick crunchy crust.
- The convection oven is an electromechanical piece of equipment and is designed to produce a consistent result. Variations in results are therefore more likely due to differences in the preparation process.

BAKING HINTS

- Always maintain a consistent cooking process. Establish a process that works for you, write it down and stick to it. Consistency in your cooking processes is very important to the quality of your bake.
- Always weigh your product. This will give you a more consistent size, color and quality.
- Do not overload pans or space product unevenly in the pan as this will create a uneven bake.
- Bent or warped pans can greatly affect the evenness of the bake.
- Always use the oven lights to view the product through the oven door windows. Do not open the oven doors during baking as this will change the baking characteristics and produce erratic results.
- If using baker's parchment, be sure the parchment does not blow over the product or obstruct air flow in any way. This will create a uneven bake. Never use aluminum foil in your convection oven.
- Use proper sheet pans for baking. Aluminum pans have better heat transference than steel pans and therefore yield much better bake results.

LOADING THE OVEN

- When loading the oven, stage products and racks so the oven doors are opened for the least amount of time during the loading process to minimize the loss of heat inside the oven.
- Center each pan on the oven shelves. Spaces should be maintained equally between the pan edges and the oven walls, front and back. This will allow for an even distribution of airflow. The better the air flow around the product, the better and more consistent the bake.
- Load the pans on the shelves as close to equal distant apart as possible. Even vertical spacing of the pans on shelves 1 thru 3 or 4 inside the oven is important to the proper circulation of air and therefore will have an effect on the quality of your bake.
 - When loading the oven randomly, (Different times for different shelves) load the oven from the center shelf out with even vertical spacing.
 - When loading multiple pans at the same time, load the shelves spaced as equal distant as possible with even vertical spacing.

UNLOADING THE OVEN

- Unload the top shelf before the bottom shelves. This is necessary because it is a characteristic of all ovens that, after the fan shuts down, rising heat and the hot oven ceiling causes the top shelf to bake quicker. This characteristic is more pronounced when baking at higher temperatures and/or for prolonged periods of time.
- Always stage your product racks so that you can unload quickly with the door open for a minimal amount of time. This is to preserve the temperature inside the oven cavity for your next round of baking.

2M-Z10761; Holman Electric Counter Top Convection Oven



CAUTION

ALWAYS KEEP THE AREA NEAR THE UNIT FREE FROM COMBUSTIBLE MATERIALS.

KEEP FLOOR IN FRONT OF EQUIPMENT CLEAN AND DRY. IF SPILLS OCCUR, CLEAN IMMEDIATELY TO AVOID THE DANGER OF SLIPS OF FALLS.

Visit our Website at: www.star-mfg.com

Email: customerservice@star-mfg.com

THOROUGHLY INSPECT YOUR UNIT ON ARRIVAL

This unit has been tested for proper operation before leaving our plant to insure delivery of your unit in perfect condition. However, there are instances in which the unit may be damaged in transit. In the event you discover any type of damage to your product upon receipt, you must immediately contact the transportation company who delivered the item to you and initiate your claim with same. If this procedure is not followed, it may affect the warranty status of the unit.

LIMITED EQUIPMENT WARRANTY

All workmanship and material in Star products have a one (1) year limited warranty on parts & labor in the United States and Canada. Such warranty is limited to the original purchaser only and shall be effective from the date the equipment is placed in service. Star's obligation under this warranty is limited to the repair of defects without charge, by the factory authorized service agency or one of its sub-agencies. Models that are considered portable (*see below*) should be taken to the closest Star service agency, transportation prepaid.

- > Star will not assume any responsibility for loss of revenue.
- > On all shipments outside the United States and Canada, see International Warranty.
- * The warranty period for the Ultra-Max, Hot Plates, Griddles, Charbroilers is (3) years parts & labor.
- * The warranty period for the Star-Max, Charbroilers, Griddles, Hot Plates, Fryers & Finishing Oven is (2) years parts & labor.
- * The warranty period for the JetStar six (6) ounce & Super JetStar eight (8) ounce series popcorn machines is two (2) years.
- * The warranty period for the Chrome-Max Griddles is five (5) years on the griddle surface. See detailed warranty provided with unit.
- * The warranty period for Dura-Tec coatings is one year under normal use and reasonable care. This warranty does not apply if damage occurs to Dura-Tec coatings from improper cleaning, maintenance, use of metallic utensils, or abrasive cleaners, abrasive pads, product identifiers and point-of-sale attachments, or any other non-food object that comes in continuous contact with the roller coating. This warranty does not apply to the "non-stick" properties of such materials.
- > This warranty does not apply to "Special Products" but to regular catalog items only. Star's warranty on "Special Products" is six (6) months on parts and ninety (90) days on labor.
- > This warranty does not apply to any item that is disassembled or tampered with for any purpose other than repair by a Star Authorized Service Center or the Service Center's sub-agency.
- > This warranty does not apply if damage occurs from improper installation, misuse, wrong voltage, wrong gas or operated contrary to the Installation and Operating instructions.
- > This warranty is not valid on Conveyor Ovens *unless* a "start-up/check-out" has been performed by a Factory Authorized Technician.

PARTS WARRANTY

Parts that are sold to repair out of warranty equipment are warranted for ninety (90) days. The part only is warranted, the labor to replace the part is **NOT** warranted.

SERVICES NOT COVERED BY WARRANTY

1. Travel time and mileage rendered beyond the 50 mile radius limit
2. Mileage and travel time on portable equipment (*see below*)
3. Labor to replace such items that can be replaced easily during a daily cleaning routine, ie; removable kettles on fryers, knobs, grease drawers on griddles, etc.
4. Installation of equipment
5. Damages due to improper installation
6. Damages from abuse or misuse
7. Operated contrary to the Operating and Installation Instructions
8. Cleaning of equipment
9. Seasoning of griddle plates
10. Voltage conversions
11. Gas conversions
12. Pilot light adjustment
13. Miscellaneous adjustments
14. Thermostat calibration and by-pass adjustment
15. Resetting of circuit breakers or safety controls or reset buttons
16. Replacement of bulbs
17. Replacement of fuses
18. Repair of damage created during transit, delivery, & installation OR created by acts of God

PORTABLE EQUIPMENT

Star will not honor service bills that include travel time and mileage charges for servicing any products considered "Portable" including items listed below. These products should be taken to the Service Agency for repair:

- * The Model 510FD, 510FF Fryer.
- * The Model 526TOA Toaster Oven.
- * The Model J4R, 4 oz. Popcorn Machine.
- * The Model 518CMA & 526CMA Cheese Melter.
- * The Model 12MC & 15MC & 18MCP Hot Food Merchandisers.
- * The Model 12NCPW & 15NCPW Nacho Chip/Popcorn Warmer.
- * All Hot Dog Equipment **except Roller Grills & Drawer Bun Warmers.**
- * All Nacho Cheese Warmers **except Model 11WLA Series Nacho Cheese Warmer.**
- * All Condiment Dispensers **except the Model HPD & SPD Series Dispenser.**
- * All Specialty Food Warmers **except Model 130R, 11RW Series, and 11WSA Series.**
- * All QCS/RCS Series Toasters **except Model QCS3 & RCS3 Series.**
- * All Fast Steamer Models **except Direct Connect Series.**

ALL:

- * Pop-Up Toasters
- * Butter Dispensers
- * Pretzel Merchandisers
(Model 16PD-A Only)
- * Pastry Display Cabinets
- * Nacho Chip Merchandisers
- * Accessories of any kind
- * Sneeze Guards
- * Pizza Ovens
(Model PO12 Only)
- * Heat Lamps
- * Pumps-Manual

The foregoing warranty is in lieu of any and all other warranties expressed or implied and constitutes the entire warranty.

FOR ASSISTANCE

Should you need any assistance regarding the Operation or Maintenance of any Star equipment; write, phone, fax or email our Service Department. In all correspondence mention the Model number and the Serial number of your unit, and the voltage or type of gas you are using.

2M-4497-2 11/21/14

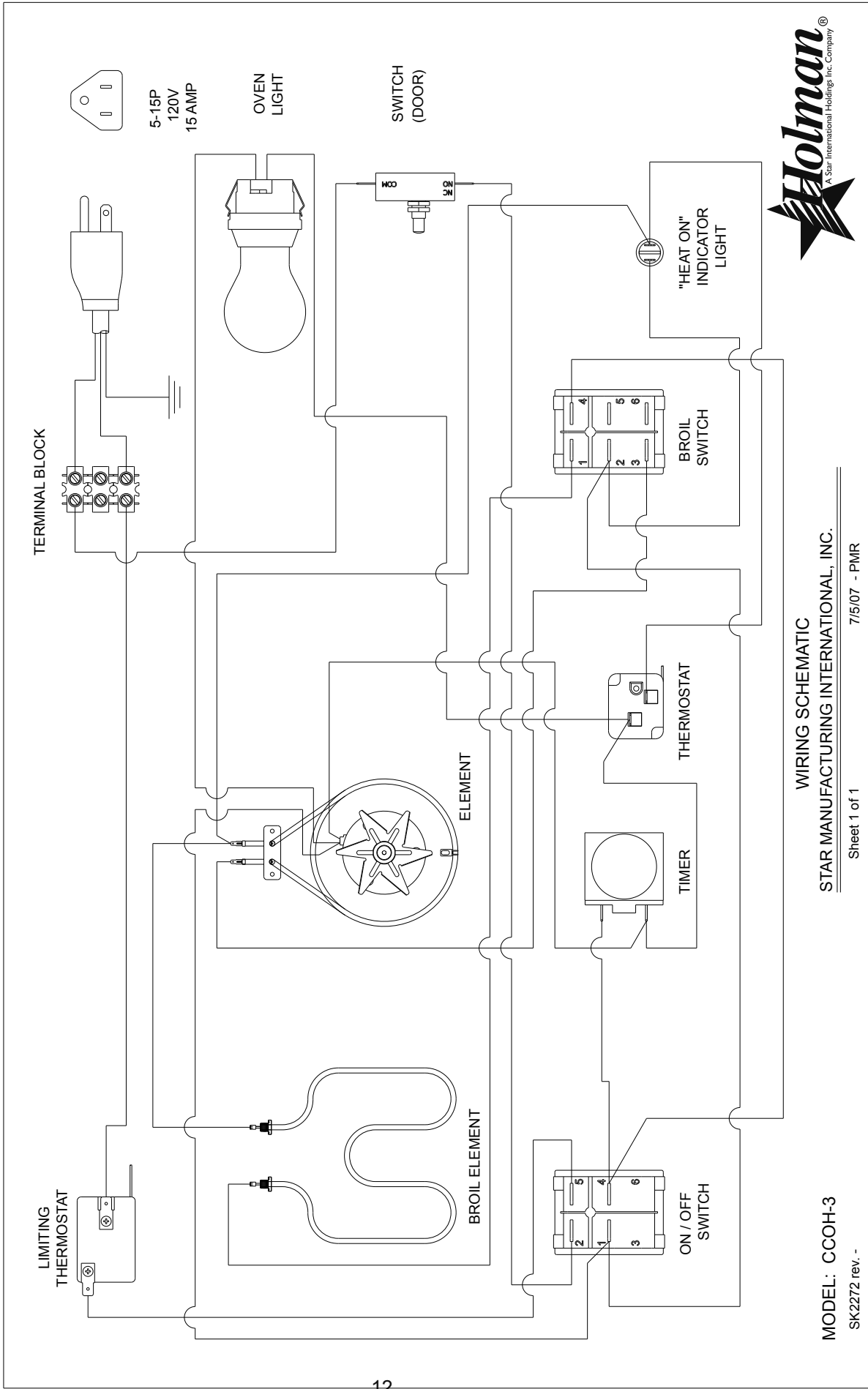

WIRING SCHEMATIC
 STAR MANUFACTURING INTERNATIONAL, INC.

MODEL: CCOH-3
 SK2272 rev. -

Sheet 1 of 1
 7/5/07 - PMR

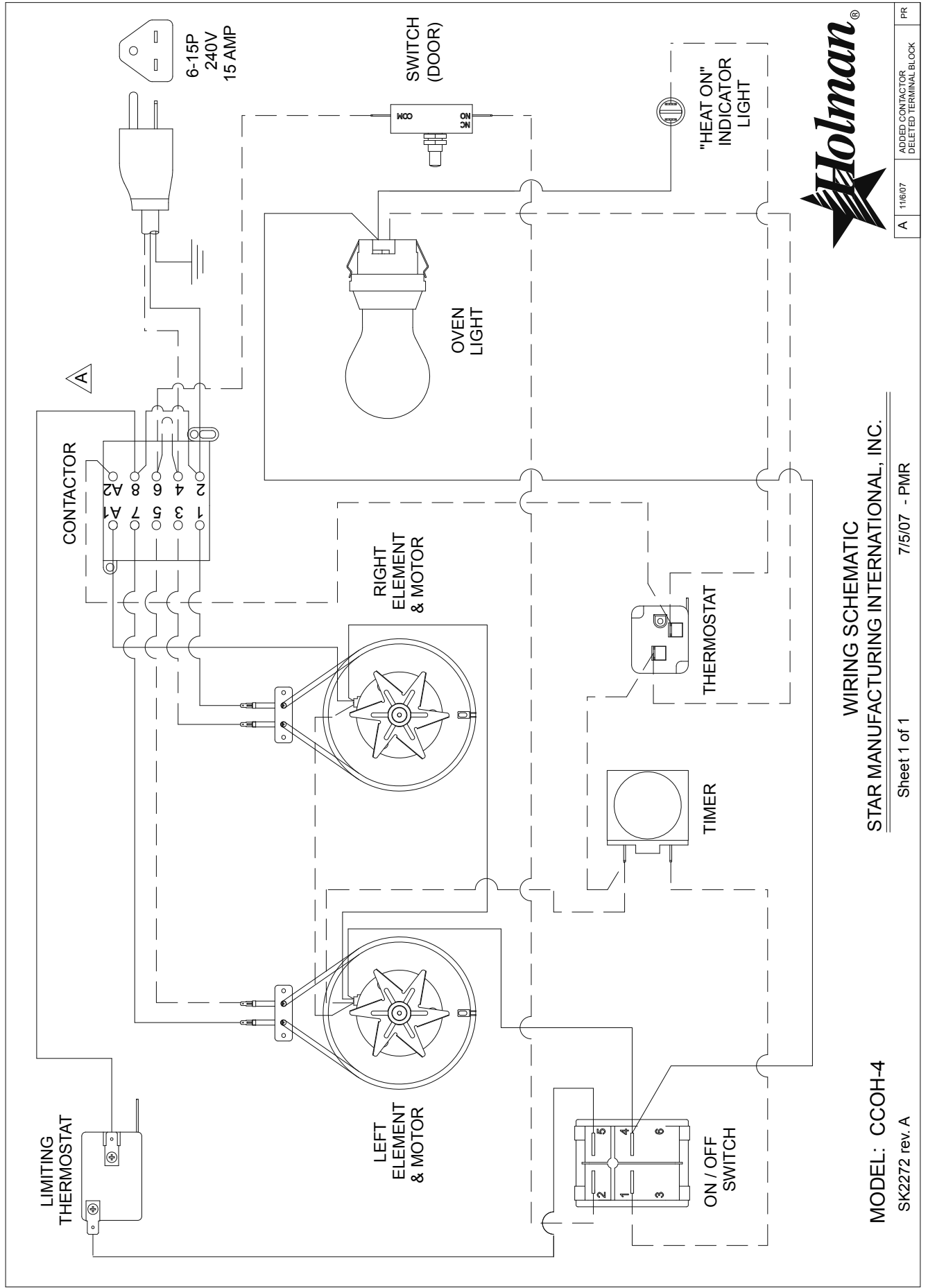

WIRING SCHEMATIC
 STAR MANUFACTURING INTERNATIONAL, INC.

MODEL: CCOH-4
 SK2272 rev. A

Sheet 1 of 1

7/5/07 - PMR

A 116/07

ADDED CONTACTOR
 DELETED TERMINAL BLOCK

PR

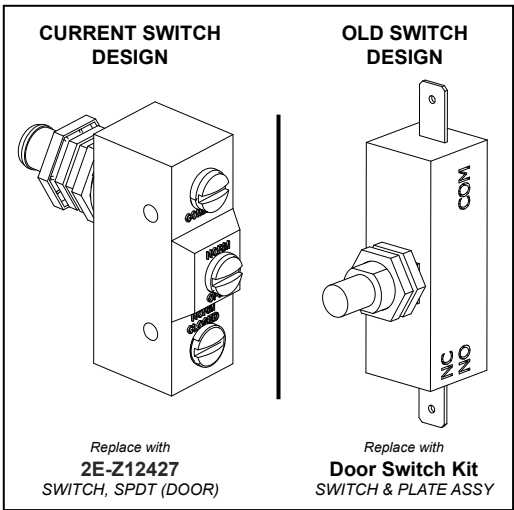

IL2102

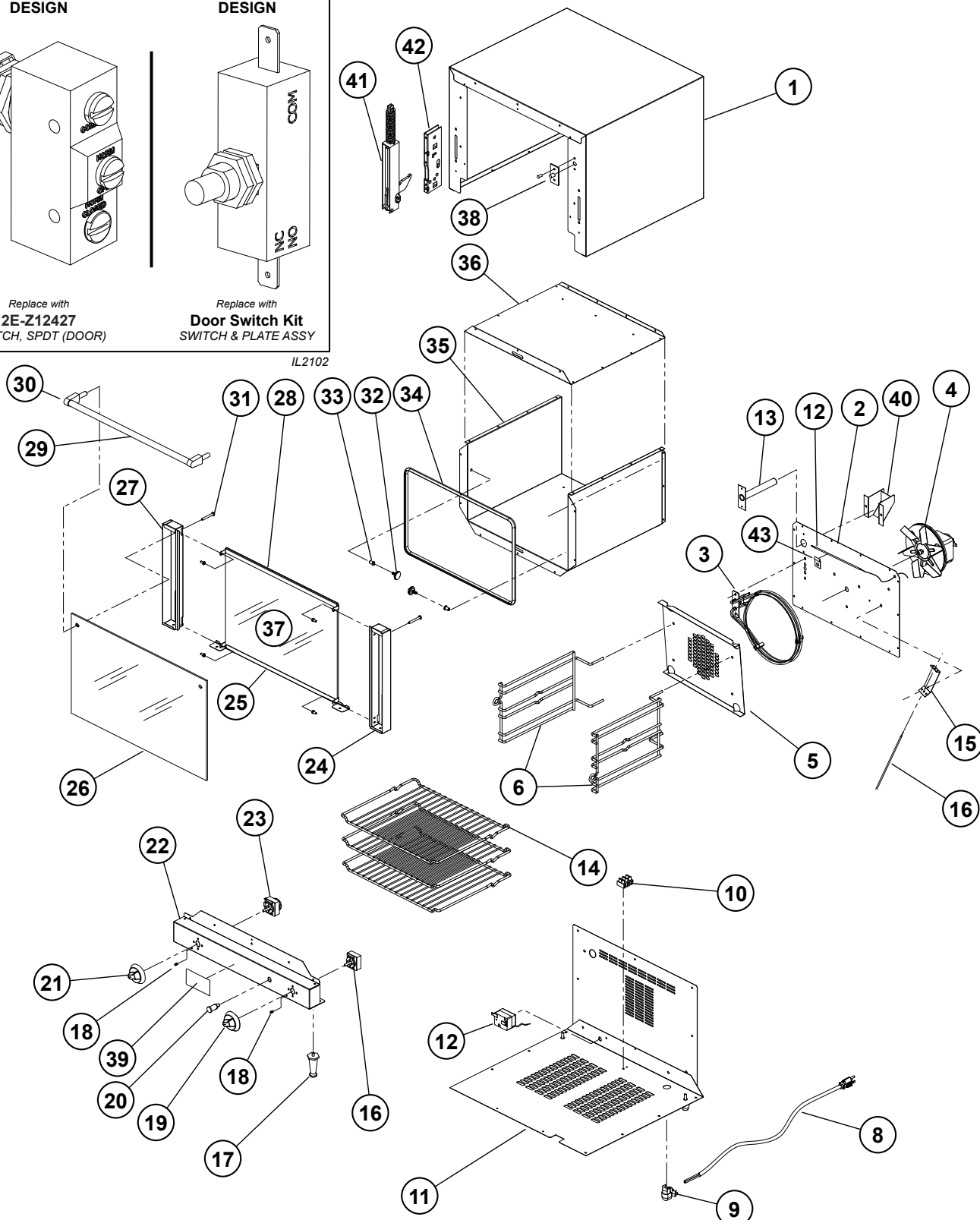

2M-Z10761; Holman Electric Countertop Top Convection Oven

MODEL:
CCOQ-3 Electric Countertop Convection Oven



SK2266 Rev. B 10/14/10

CCOQ-3 COUNTER TOP CONVECTION OVEN

Key Number	Part Number	Number Per Unit	Description
1	F9-Z10707	1	BODY WRAP
2	F9-Z10710	1	REAR, OVEN CHAMBER
3	2N-Z10735	1	ELEMENT 1400W, 120V
	2N-Z14807	1	ELEMENT 120V CCOQ-3-220V
4	2U-Z10736	1	MOTOR/FAN ASSEMBLY
	2U-Z11018	1	MOTOR CCOQ-3-220V
5	F9-Z10713	1	PANEL, AIR DISTRIBUTOR
6	2B-Z10743	2	L/R RACK SUPPORT
7	F9-Z10712	1	PANEL, REAR COVER-OVEN
8	2E-Z8861	1	CORD, POWER, 120V
	2E-Z7242	1	CORD POWER, 220V
9	2E-Z10730	1	STRAIN RELIEF
10	2E-Z10731	1	TERMINAL BLOCK
11	F9-CN0006	1	BODY BOTTOM PLATE ASSY
12	2E-Z10732	1	HIGH LIMIT
13	F9-CN0005	1	VENT TUBE
14	2B-Z10744	3	RACK
15	F9-Z10716	1	BRACKET, TSTAT PROBES
16	2T-Z10733	1	THERMOSTAT
17	2A-Z1485	4	FOOT 1" ADJUSTABLE
18	2E-Z10727	3	INDICATOR, RED RUBBER
19	2R-Z10724	1	KNOB, TEMPERATURE
20	2J-Y6689	1	PILOT LIGHT
21	2R-Z10723	1	KNOB, TIMER
22	F9-Z10711	1	PANEL, CONTROL
23	2E-Z10734	1	TIMER, OVEN
	2E-Z12036	1	TIMER, 10 MINUTE CCOQI-3
24	F9-Z10703	1	SUPPORT, DOOR RIGHT
25	F9-Z10705	1	SUPPORT, DOOR BOTTOM
26	2Q-Z10721	1	GLASS, OUTER
27	F9-Z10702	1	SUPPORT, DOOR LEFT
28	F9-Z10704	1	SUPPORT, DOOR TOP
29	2V-Z10741	1	ROD, HANDLE
30	2I-Z10726	2	HANDLE-END, DOOR
31	2C-1557	2	SCREW 10-24X1 1/2 RHP STL np
32	2C-Z10749	2	THUMBSCREW, SHELF
33	2C-Z10750	2	SCREW, SHELF RIVET
34	2I-Z10770	1	GASKET, DOOR COMPLETE CCOQ
35	F9-Z10709	1	OVEN CHAMBER, BOTTOM
36	F9-Z10717	1	OVEN CHAMBER, TOP
37	2Q-Z10722	1	INNER GLASS, TEMPERED
38	PS-CN0064	1	SWITCH, DOOR KIT (BRACKET, WIRE, SWITCH)
39	2M-Z10358	1	HOLMAN LOGO
40	F9-Z10763	1	HEAT SHIELD
41	2F-Z10745	2	HINGE, DOOR
42	2F-Z10769	2	RECEIVER, HINGE DOOR
43	2P-Z7670	2	HALF CLIP
NI	2C-Z10474	50	SCREW (BODY)
NI	2C-Z10748	3	SCREWS, MOTOR MOUNTING
NI	2C-Z10753	2	SCREW, TIMER
NI	2C-Z10754	6	WASHER, HINGE
NI	2C-Z10756	6	SCREW, HINGE
NI	2C-Z10757	2	SCREW, THERMOSTAT
NI	2C-Z10758	2	SCREW, BLOCK TERMINAL
NI	F9-CN0002	1	DOOR ASSEMBLY COMPLETE (no hinges)

2M-Z10761; Holman Electric Counter Top Convection Oven

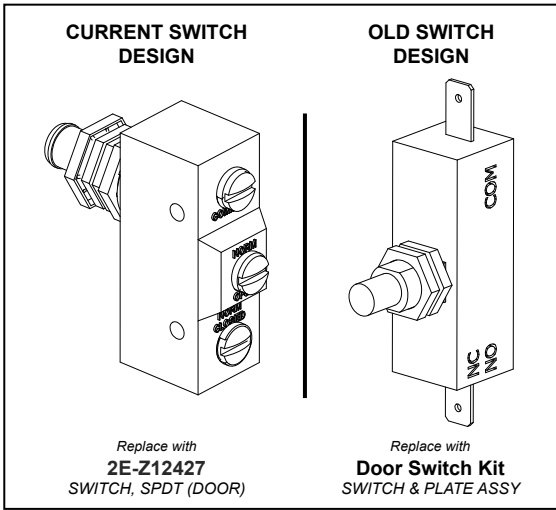

IL2102

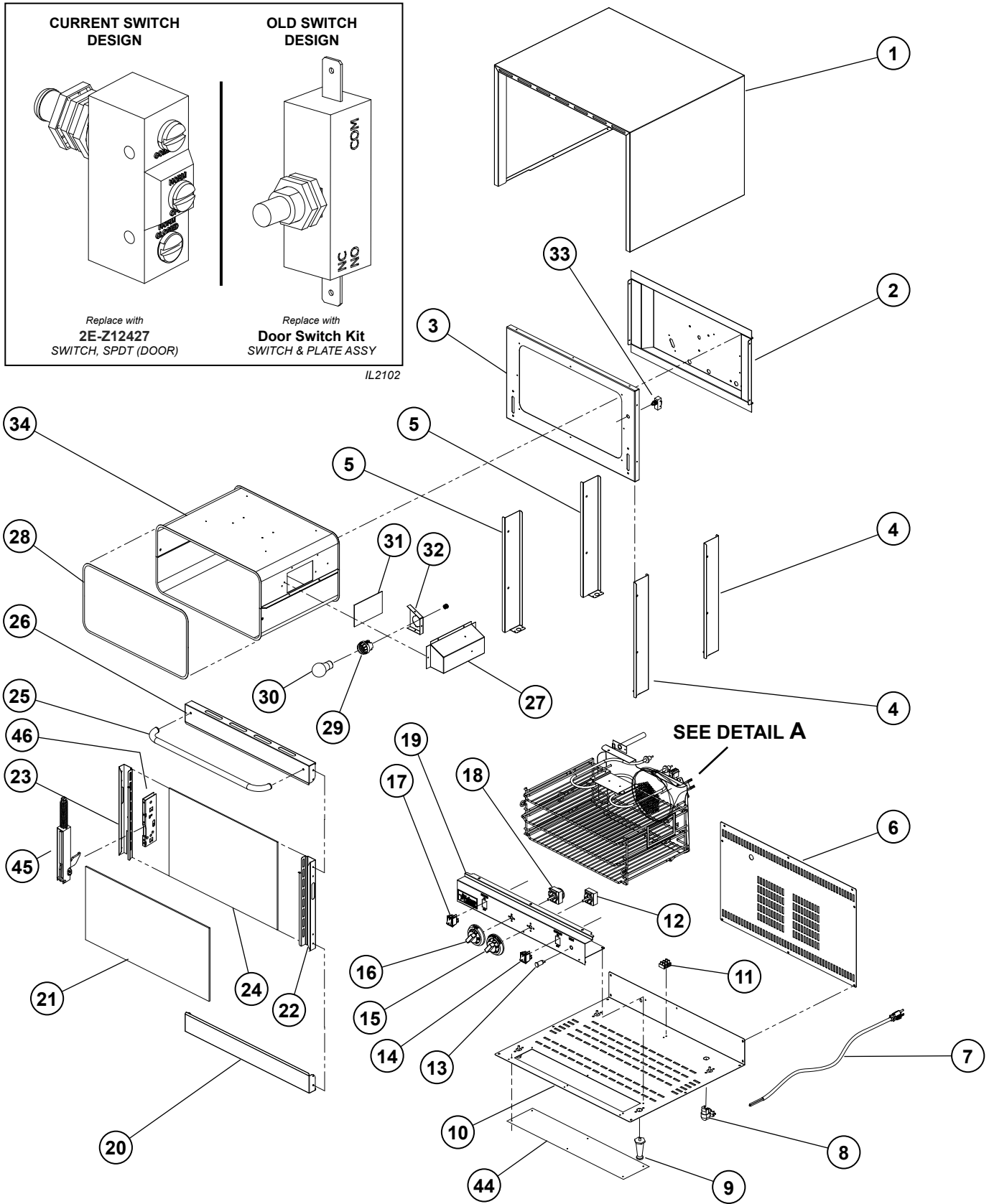

2M-Z10761: Holman Electric Countertop Convection Oven



MODEL:
CCOH-3 Electric Countertop Convection Oven¹⁶

SK2267 Rev. F 11/18/15

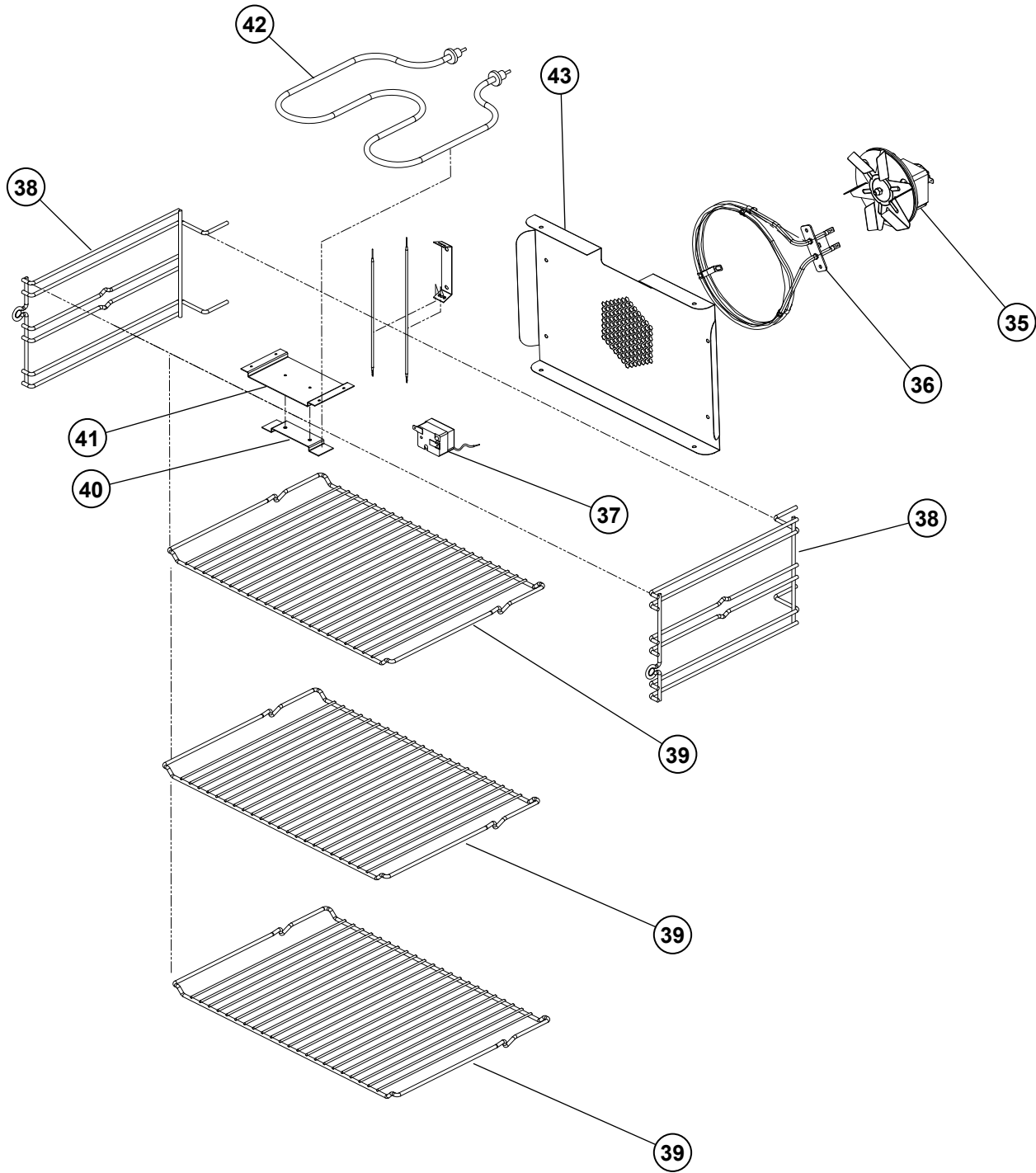

Detail A

MODEL:
CCOH-3



SK2268 Rev. - 8/1/07

PARTS LIST

March 15, 2015, Rev. I

CCOH-3 COUNTER TOP CONVECTION OVEN

Key Number	Part Number	Number Per Unit	Description	
1	F9-Z10915	1	BODY WRAP	
2	F9-Z10907	1	REAR, OVEN CHAMBER	
3	F9-Z10906	1	FRONT FACE, OVEN CHAMBER	
4	F9-Z10910	2	SUPPORT, OVEN CHAMBER RIGHT	
5	F9-Z10909	2	SUPPORT, OVEN CHAMBER LEFT	
6	F9-Z10913	1	PANEL, REAR COVER-OVEN	
7	D9-Z8861	1	CORD, POWER, 120V	
	D9-Z7242			
8	2E-Z10730	1	STRAIN RELIEF	
9	2R-Y5092	4	FOOT	
10	F9-Z10911	1	PLATE, BOTTOM OVEN	
11	2E-Z10731	1	TERMINAL BLOCK	
12	2T-Z10733	1	THERMOSTAT	
13	2J-Y6689	1	PILOT LIGHT	
14	2E-Z10950	1	SWITCH, BROILER	
15	2R-Z12007	1	KNOB, TEMPERATURE	
16	2R-Z10935	1	KNOB, TIMER	
17	2E-Z10942	1	SWITCH, ON/OFF	
18	2E-Z10734	1	TIMER, OVEN	
19	F9-Z10912	1	PANEL, CONTROL	CCOH-3
	F9-Z11010	1	PANEL, CONTROL	CCOH-3NB
20	F9-Z10903	1	SUPPORT, DOOR BOTTOM	
21	2Q-Z10932	1	GLASS, OUTER	
22	F9-Z10901	1	SUPPORT, DOOR RIGHT	
23	F9-Z10900	1	SUPPORT, DOOR LEFT	
24	2Q-Z10933	1	GLASS, INNER	
25	2V-Z10943	1	ROD, HANDEL	
26	F9-Z10902	1	SUPPORT, DOOR TOP	
27	F9-Z10917	1	LIGHT HOUSING	
28	2I-Z10927	1	DOOR GASKET COMPL, ASSY	
29	2E-Y9184	1	SOCKET, LIGHT	
30	2S-1279	1	LIGHT BULB	
31	2Q-Z10934	1	GLASS, LAMP COVER	
32	F9-Z10916	1	LIGHT SOCKET HOLDER	
33	PS-CN0063	1	CCOH-3 DOOR SWITCH KIT (BRACKET, WIRE, SWITCH)	
34	F9-CN0019	1	OVEN CHAMBER WELD ASSY	
35	2U-Z10736	1	MOTOR/FAN ASSEMBLY	
	2U-Z11018	1	MOTOR/FAN ASSEMBLY	CCOH-3-220V
36	2N-Z10735	1	ELEMENT 1400W, 120V	
	2N-Z14808	1	ELEMENT	CCOH-3-220V
37	2E-Z10732	1	HIGH LIMIT	
38	2B-Z21717	2	L/R RACK SUPPORT	
39	2B-Z10944	3	RACK	
40	F9-Z10919	1	TOP HEATING ELEMENT BRACKET	
41	F9-Z10918	1	BRACKET, SUPPORT HEATING ELEMENT	
42	2N-Z10939	1	ELEMENT, TOP, 1400W/120V	CCOH-3
43	F9-Z21754	1	PANEL, AIR DISTRIBUTOR	
44	F9-Z10914	1	PLATE, BOTTOM, COVER-OVEN #2	
45	2F-Z10946	2	HINGE, DOOR	
46	2F-Z10769	2	HINGE RECIEVER	
NI	F9-CN0016	1	DOOR ASSEMBLY COMPLETE	

2M-Z10761; Holman Electric Counter Top Convection Oven

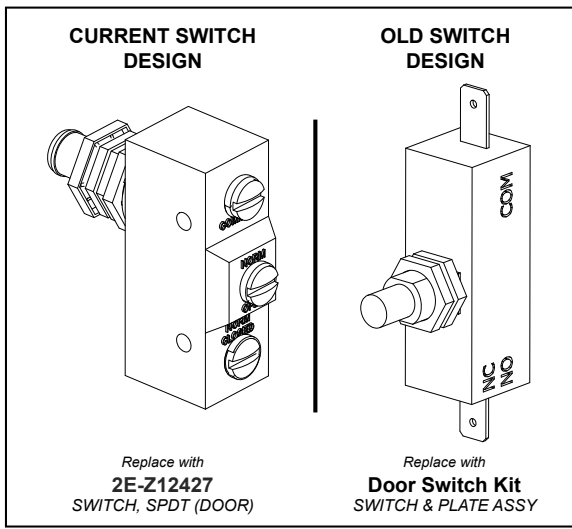

IL2102

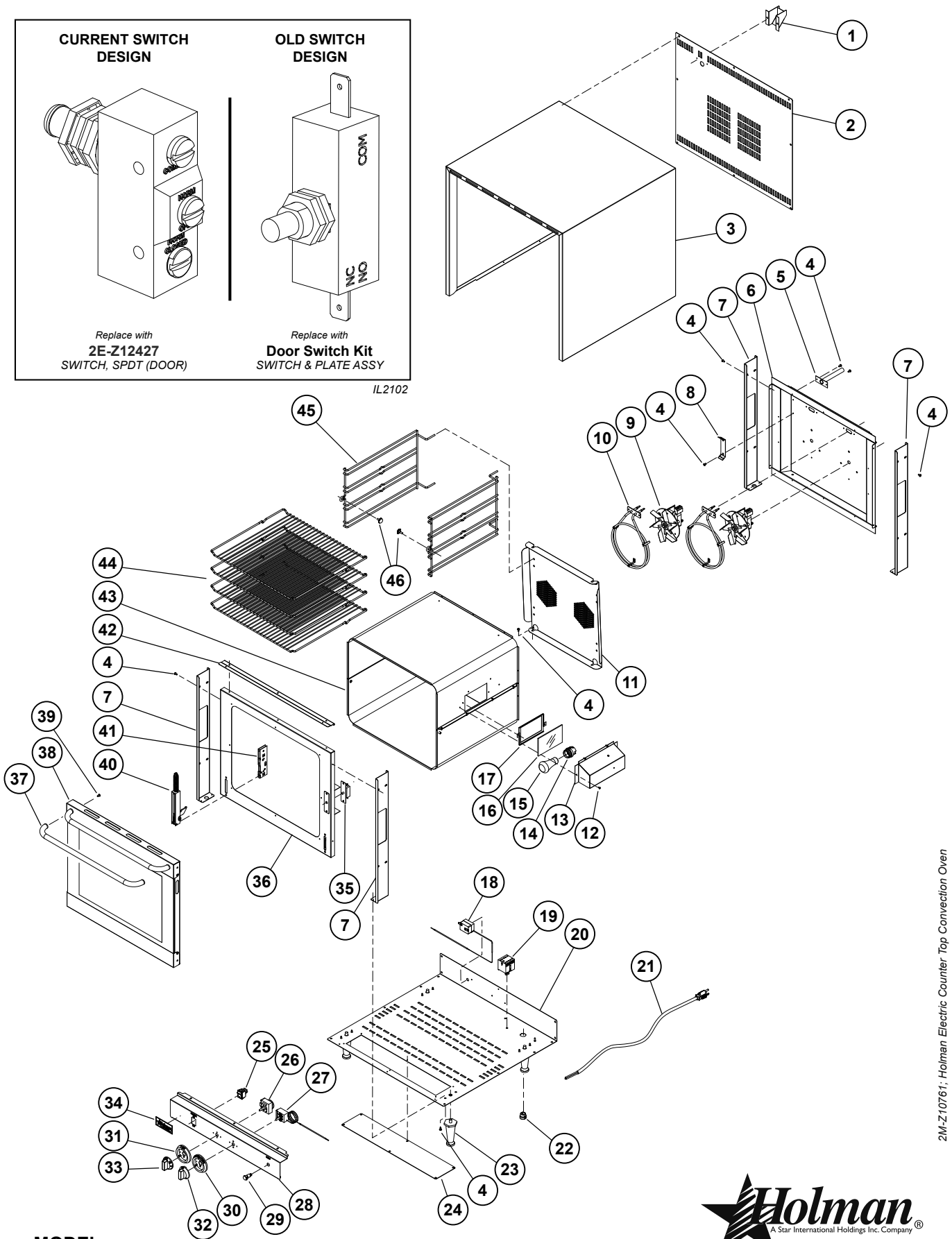

MODEL:
CCOH-4 Electric Countertop Convection Oven



SK2337 Rev. C 10/14/10

2M-Z10761; Holman Electric Countertop Convection Oven

PARTS LIST

March 15, 2015, Rev. I

CCOH-4 COUNTER TOP CONVECTION OVEN

Key Number	Part Number	Number Per Unit	Description
1	F9-Z10763	1	HEAT DEFLECTOR
2	F9-Z11011	1	REAR COVER PLATE
3	F9-Z11012	1	BODY WRAP
4	2C-6349	27	SCREW #8X3/8 B THP STL NP
5	F9-CN0005	1	VENT TUBE ASSEMBLY
6	F9-Z11005	1	OVEN CHAMBER REAR
7	F9-Z11033	4	OVEN CHAMBER SUPPORT COM
8	F9-Z10716	1	BRACKET, THERMOSTAT
9	2U-Z11018	2	MOTOR
10	2N-Z11017	2	ELEMENT 230V 1250W
11	F9-Z11008	1	OVEN CHAMBER FAN COVER
12	2C-H2515	11	RIVET 1/8X1/4 POP AL AM
13	F9-CN0024	1	LIGHT HOUSING ASSEMBLY
14	2E-Y9184	1	SOCKET
15	2S-Z11021	1	LIGHT BULB 230V 25W
16	2Q-Z10934	1	LAMP GLASS
17	F9-Z10923	1	LIGHT GUARD FRAME
18	2E-Z10732	1	TEMPERATURE LIMITING CTRL
19	2E-Z11028	1	CONTACTOR B6-40-00
20	F9-CN0038	1	BOTTOM PLATE ASSY
21	F9-CN0042	1	POWER CORD ASSY 14/3 6-15
22	2K-Y6764	1	BUSHING - STRAIN RELIEF
23	2R-Y5092	4	BLACK PLASTIC LEG
24	F9-Z10914	1	PLATE,BOTTOM,COVER-OVEN
25	2E-Z1858	2	SWITCH-LIGHTED
26	2E-Z10734	1	TIMER, 120 MINUTE
27	2T-Z10733	1	THERMOSTAT
28	F9-Z11010	1	CONTROL PANEL
29	2J-Y6690	1	PILOT LIGHT 240V
30	2F-Z10948	1	TEMPERATURE BEZEL
31	2F-Z10947	1	TIME BEZEL-CONTROL PANEL
32	2R-Z12007	1	KNOB, TEMPERATURE
33	2R-Z10935	1	KNOB, TIMER
34	2M-Z10358	1	LOGO PLATE-HOLMAN
35	PS-CN0065	1	SWITCH, SPDT (DOOR) (BRACKET, WIRE, SWITCH)
36	F9-Z11004	1	OVEN CHAMBER FRONT FACE
37	2V-Z10943	1	HANDLE - DOOR
38	F9-CN0040	1	DOOR ASSEMBLY
39	2C-1512	2	SCREW 10-24X3/8 RHP STL
40	2F-Z11022	2	DOOR HINGE
41	2F-Z10769	2	HINGE RECEIVER
42	F9-Z10925	1	FLANGE - TOP SUPPORT
43	F9-CN0039	1	OVEN CHAMBER ASSY
43	F9-Z11002	1	OVEN CHAMBER LOWER HALF
43	F9-Z11003	1	OVEN CHAMBER UPPER HALF
44	2B-Z11023	4	OVEN RACK
45	2B-Z11024	2	RACK SUPPORT L/R
46	2C-Z10749	2	THUMB SCREW M5X13.00MM
NI	2H-Z10738	2	MOTOR INSULATION
NI	2H-Z11019	1	INSULATION - OVEN BACK
NI	2H-Z11020	1	INSULATION - OVEN SIDES
NI	2I-Z11029	1	DOOR GASKET ASSEMBLY
NI	2K-Y1139	1	BUSHING HEYCO SB500-6

2M-Z10761; Holman Electric Counter Top Convection Oven

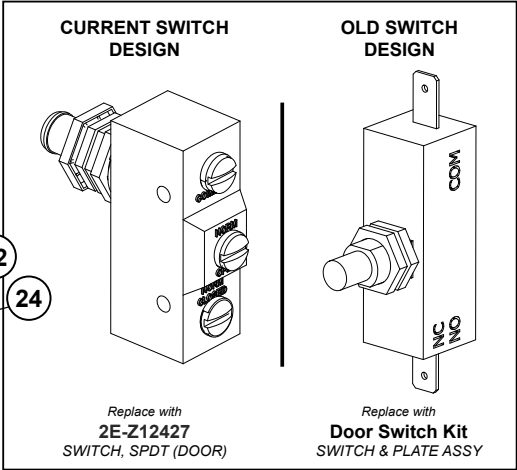
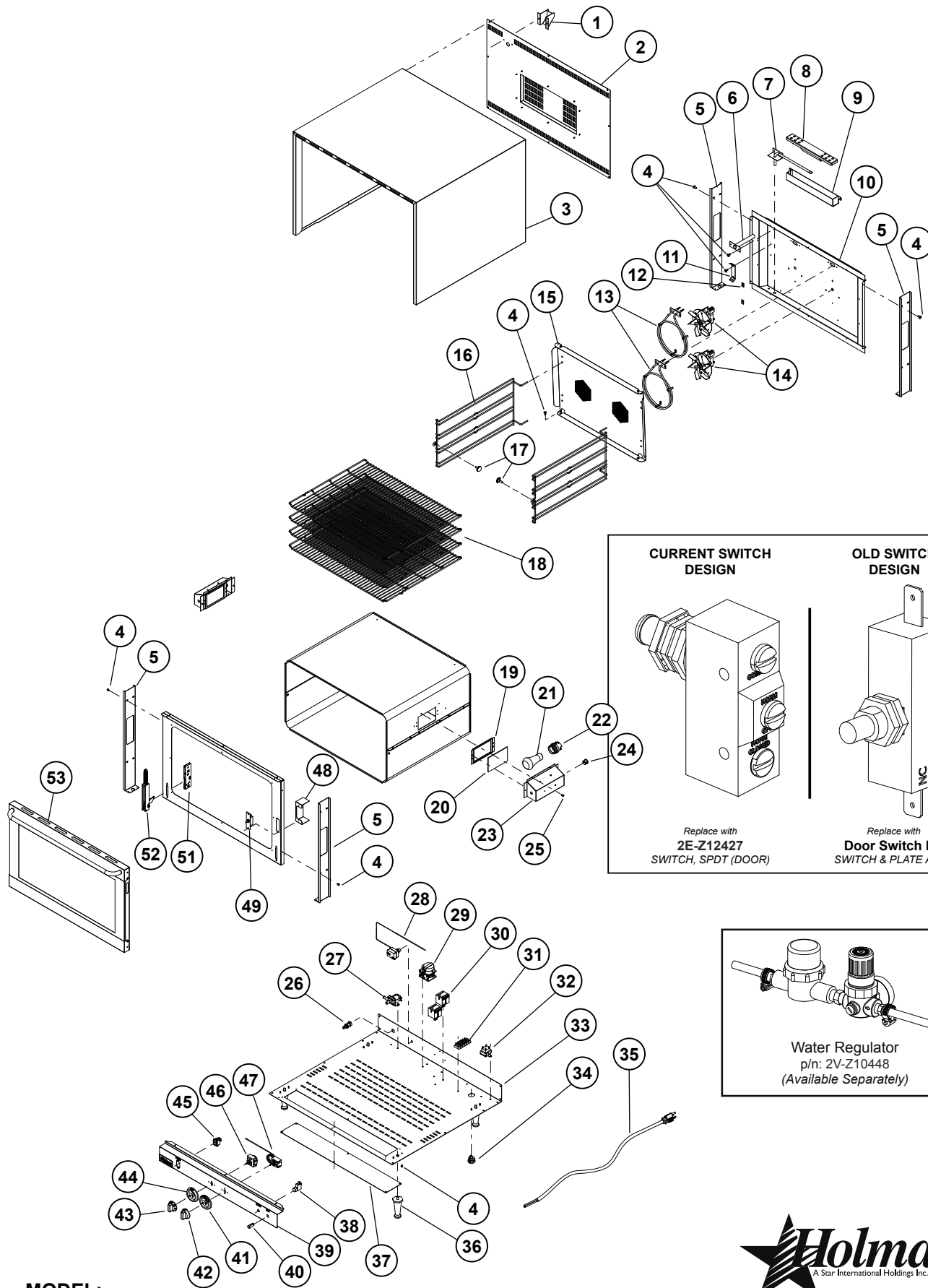

IL2102

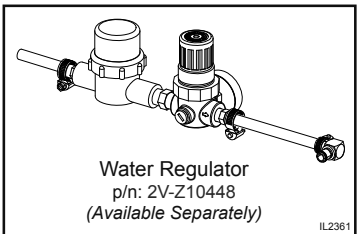

IL2361

2M-Z10761; Holman Electric Countertop Convection Oven

MODEL:
 CCOF-4 Electric Countertop Convection Oven



SK2352 Rev. C 02/17/14

PARTS LIST

March 15, 2015, Rev. I

CCOF-4 COUNTER TOP CONVECTION OVEN

Key Number	Part Number	Number Per Unit	Description
1	F9-Z10763	1	HEAT DEFLECTOR
2	F9-CN0048	1	REAR PANEL ASSEMBLY
3	F9-Z11111	1	BODY WRAP
4	2C-6349	24	SCREW #8X3/8 B THP STL NP
5	F9-Z11033	4	OVEN CHAMBER SUPPORT COM
6	F9-CN0005	1	VENT TUBE ASSEMBLY
7	2V-Z11279	1	STEAM TUBE ASSEMBLY
8	F9-CN0060	1	STEAM BOX COVER ASSY
9	F9-CN0059	1	STEAM BOX ASSY
10	F9-Z11105	1	OVEN CHAMBER REAR
11	F9-Z10716	1	BRACKET, THERMOSTAT
12	2P-Z7670	2	HALF CLIP - .125 DIA.
13	2N-Z11117	2	HEATING ELEMENT ROUND
14	2U-Z11118	2	MOTOR/FAN ASSEMBLY
15	F9-Z11106	1	OVEN CHAMBER FAN COVER
16	2B-Z11128	2	RACK SUPPORT LEFT/RIGHT
17	2C-Z10749	2	THUMB SCREW M5X13.00MM
18	2B-Z11126	4	OVEN RACK
19	F9-Z11135	2	GLASS COVER FRAME COMMON
20	2Q-Z10934	2	LAMP GLASS
21	2S-Z11021	2	LIGHT BULB 230V 25W
22	2E-Y9184	2	SOCKET
23	F9-CN0024	1	LIGHT HOUSING ASSEMBLY
23	F9-CN0047	1	LIGHT HOUSING ASSY RIGHT
24	2K-Y1139	2	BUSHING HEYCO SB500-6
25	2C-H2515	12	RIVET 1/8X1/4 POP AL AM
26	2K-Z10080	1	Q-D MALE/3/8 HOSE PANEL
27	2V-Z9988	1	FLUID CONTROL VALVE, 12V
28	2E-Z10732	1	TEMPERATURE LIMITING CTRL
29	2P-Z11121	1	REVERSE CAM TIMER
30	2E-Z11028	2	CONTACTOR B6-40-00
31	2E-Z2894	1	TERMINAL BLOCK (304)
32	2E-05-07-0350	1	TRANSFORMER 230V/10V 6VA
33	F9-Z11107	1	BOTTOM PLATE
34	2K-3485	1	BUSHING HEYCO #SR-9
35	2E-Z2922	1	CORD STO 10/3NEMA L6-30P
36	2R-Y5092	4	BLACK PLASTIC LEG
37	F9-Z11110	1	BOTTOM COVER PLATE
38	2E-Z3682	1	SWITCH-MOMENTARY
39	F9-Z11108	1	CONTROL PANEL
40	2J-Y6689	1	PILOT LIGHT 120V
41	2F-Z10948	1	TEMPERATURE BEZEL -
42	2R-Z12007	1	KNOB, TEMPERATURE
43	2R-Z10935	1	KNOB, TIMER
44	2F-Z10947	1	TIME BEZEL-CONTROL PANEL
45	2E-Z1858	1	SWITCH-LIGHTED
46	2E-Z10734	1	TIMER, 120 MINUTE
47	2T-Z10733	1	THERMOSTAT
48	F9-Z10957	1	HEAT SHEILD SWITCH
49	PS-CN0066	1	SWITCH, SPDT (DOOR) (BRACKET, WIRE, SWITCH)
50			
51	2F-Z10769	2	HINGE RECEIVER
52	2F-Z11127	2	DOOR HINGE
53	F9-CN0046	1	DOOR ASSEMBLY
NI	C9-Z11123	1	SILICONE HOSE INLET
NI	C9-Z11124	1	SILICONE HOSE OUTLET
NI	2I-Z11136	1	DOOR GASKET ASSY

2M-Z10761: Holman Electric Counter Top Convection Oven

STAR MANUFACTURING INTERNATIONAL INC.

Star - Holman - Lang - Wells - Toastmaster

265 HOBSON ST. SMITHVILLE, TN 37166

(800) 264-7827

www.star-mfg.com